

---

---

SERVICE BULLETIN

N° **139-703**

**OPTIONAL**

**DATE:** October 17, 2023

**REV. :** /

---

---

**TITLE**

**ATA 34 – AIS TRANSPONDER KIT INSTALLATION**

**REVISION LOG**

First Issue

## **PLANNING INFORMATION**

### **A. EFFECTIVITY**

All AW139 helicopters from S/N 31400 to S/N 31699 and from S/N 41300 to S/N 41499.

### **B. COMPLIANCE**

At Customer's option.

### **C. CONCURRENT REQUIREMENTS**

N.A.

### **D. REASON**

This Service Bulletin is issued in order to provide the necessary instructions on how to perform the installation of kit AIS transponder P/N 4G3450F00415.

LH issued this SB for the following reason:

Helicopter Reliability/Maintainability	
Product Improvement	
Obsolescence	
Customization	✓
Product/Capability Enhancement	

### **E. DESCRIPTION**

The Automatic Identification System (AIS) Transponder is an ITU-R M.1371-1-based SAR AIS transponder, allowing identification and position definitions of surrounding flying objects. It can operate either in AIS mode as SAR station, or in one of several tactical modes, allowing tactical communications on separate channels.

The information detected and/or transmitter by the AIS transponder are visualized on the Digital Map displays through RS-422 bus lines. These information identify the coordinates (lat/log) of the target detected and are superimposed to the digital map display.

The transponder is continuously updated with navigational data containing the helicopter's current position through internal GPS receiver.

### **F. APPROVAL**

The technical content of this Service Bulletin is approved under the authority of DOA nr. EASA.21.J.005. For helicopters registered under other Aviation Authorities, before

applying the Service Bulletin, applicable Aviation Authority approval must be checked within Leonardo Helicopters customer portal.

EASA states mandatory compliance with inspections, modifications or technical directives and related time of compliance by means of relevant Airworthiness Directives. If an aircraft listed in the effectivity embodies a modification or repair not LHD certified and affecting the content of this Service Bulletin, it is responsibility of the Owner/Operator to obtain a formal approval by Aviation Authority having jurisdiction on the aircraft, for any adaptation necessary before incorporation of the present Service Bulletin.

## G. MANPOWER

To comply with this Service Bulletin approximately forty-five (45) MMH are deemed necessary.

MMH are based on hands-on time and can change with helicopter configuration, personnel and facilities available. MMH are not comprehensive of the overall hours necessary to get access to work areas and to remove all the equipment that interferes with the application of the prescribed instructions.

## H. WEIGHT AND BALANCE

WEIGHT (Kg)	ARM (mm)	MOMENT (Kgmm)
		4,89
LONGITUDINAL BALANCE	7441	36386
LATERAL BALANCE	-608	-2973

## I. REFERENCES

### I.1 PUBLICATIONS

Following Data Modules refer to AMP:

<u>DATA MODULE</u>	<u>DESCRIPTION</u>	<u>PART</u>
DM01 39-A-00-20-00-00A-120A-A	Helicopter on ground for a safe maintenance	-
DM02 39-A-06-41-00-00A-010A-A	Access doors and panels - General data.	-
DM03 39-A-11-00-01-00A-720A-A	Decal – Install procedure	-
DM04 39-B-34-59-00-00A-320A-K	AIS transponder system - Operation test	-
DM05 39-B-34-59-01-00A-720A-K	AIS transponder - Install procedure	-
DM06 39-E-34-59-02-00A-720A-K	VHF antenna - Install procedure	-

Following Data Modules refer to CSRP:

<u>DATA MODULE</u>	<u>DESCRIPTION</u>	<u>PART</u>
DM07 CSRP-A-51-42-00-00A-720A-D	Potted Inserts - Install procedure	-

## **I.2 ACRONYMS& ABBREVIATIONS**

AIS	Automatic Identification System
AMDI	Aircraft Material Data Information
AMP	Aircraft Maintenance Publication
AR	As Required
DM	Data Module
DOA	Design Organization Approval
EASA	European Aviation Safety Agency
IPD	Illustrated Part Data
ITEP	Illustrated tool and equipment publication
LH	Left Hand
LHD	Leonardo Helicopters Division
MMH	Maintenance Man Hours
N.A.	Not Applicable
P/N	Part Number
RH	Right Hand
SB	Service Bulletin
S/N	Serial Number

## **I.3 ANNEX**

N.A.

## **J. PUBLICATIONS AFFECTED**

N.A.

## **K. SOFTWARE ACCOMPLISHMENT SUMMARY**

N.A.

## 2. MATERIAL INFORMATION

### A. REQUIRED MATERIALS

#### A.1 PARTS

#	P/N	ALTERNATIVE P/N	DESCRIPTION	Q.TY	LVL	NOTE	LOG P/N
1	4G3450F00415		KIT AIS TRANSPONDER	REF	.		-
2	4G3450A01215		AIS TRANSPONDER EQUIPMENT INSTALLATION	REF	..		
3	16355		Antenna VHF	1	...		139-703L1
4	7001-000-131		Kit AIS transponder	1	...	(1)	139-703L1
5	A601A2B15		Bonding cable assy	1	...		139-703L1
6	ED300A163		Decal	1	...		139-703L1
7	ED300E41		Decal	1	...		139-703L1
8	LN9025-0410N		Washer	1	...		139-703L1
9	LN9338-04		Nut	1	...		139-703L1
10	MS20995C41		Lock Wire	0,45 kg	...		139-703L1
11	MS35207-265		Screw	4	...		139-703L1
12	NAS1149DN816J		Washer	4	...		139-703L1
13	NAS1801-08-6	NAS1801-08-06	Screw	4	...		139-703L1
14	4G3450A01314		AIS TRANSPONDER COMPLETE PROVISION	REF	..		
15	3G5310A25813		STRUCTURAL PROVISION FOR AIS TRANSPONDER	REF	...		
16	3G5316A50731		Antenna support assy	1	....		139-703L1
17	3G5316A50851		Closure sheet	1	....		139-703L1
18	3G5316A50951		Plate	1	....		139-703L1
19	3P5315A12532		Bracket assy	1	....		139-703L1
20	999-5000-30-109	AW007TE-30-109	Insert	2	....		139-703L1
21	A423A3C8		Nut plate	2	....		139-703L1
22	MS20470AD3-7		Rivet	0,1 kg	....		139-703L1
23	MS20470AD4-7		Rivet	0,1 kg	....		139-703L1
24	MS21069L08	MS21069-08	Nut plate	2	....		139-703L1
25	MS27039-1-07		Screw	6	....		139-703L1
26	NAS1149D0332K		Washer	6	....		139-703L1
27	NAS1836C08-13M		Insert	5	....		139-703L1
28	4G3450A01413		AIS TRANSPONDER ELECTRICAL PROVISION	REF	...		
29	3G9B01A32301	3G9B01A32301A10R	AIS transponder C/A (B1A323)	1	....		139-703L1
30	3G9C01A23001	4G3450A01413A1R	AIS transponder C/A (C1A230)	1	....		139-703L1
31	3G9C02A21701		AIS transponder C/A (C2A217)	1	....		139-703L1
32	3G9C03A20401	3G9C03A20401A10R	AIS transponder C/A (C3A204)	1	....		139-703L1
33	3G9C03C20001	3G9C03C20001A10R	AIS transponder C/A (C3C200)	1	....		139-703L1
34	3G9D03A20202		AIS transponder C/A (D3A202)	1	....		139-703L1
35	A236A03AB		Non Metallic Channel	1,2 m	....		139-703L1
36	A366A3E12C		Stud	4	....		139-703L1
37	A366A3E18C		Stud	1	....		139-703L1

#	P/N	ALTERNATIVE P/N	DESCRIPTION	Q.TY	LVL	NOTE	LOG P/N
38	A366A3E18C75		Stud	1	....		139-703L1
39	A366A3E22C		Stud	2	....		139-703L1
40	A366A3E22C75		Stud	3	....		139-703L1
41	A366A3E30C		Stud	1	....		139-703L1
42	A366A3E32C		Stud	2	....		139-703L1
43	A388A3E12C75		Standoff	1	....		139-703L1
44	A522A04A		Terminal module rail	1	....		139-703L1
45	A524A2A-A		Identification Label	1	....		139-703L1
46	A524A3A-A		Identification Label	1	....		139-703L1
47	EN6049-006-05-5	A582A05	Nomex	2,5 m	....		139-703L1
48	EN6049-006-08-5	A582A08	Nomex	2,5 m	....		139-703L1
49	EN6049-006-13-5	A582A12	Nomex	2,5 m	....		139-703L1
50	A582A32	EN6049-006-32-5	Nomex	2,5 m	....		139-703L1
51	A593A-A01		Terminal Board	1	....		139-703L1
52	A593A-A04		Terminal Board	1	....		139-703L1
53	A631A01A		Spacers	4	....		139-703L1
54	A631A02A		Spacers	3	....		139-703L1
55	AW001CB03H		Clamp	3	....		139-703L1
56	AW001CB04H		Clamp	7	....		139-703L1
57	AW001CL000A-X3		Support	5	....		139-703L1
58	AW001TL3A08T		Anchor Nut	2	....		139-703L1
59	AW002FT102		Grommet	7	....		139-703L1
60	AW002FT103		Grommet	3	....		139-703L1
61	AW002FT503		Grommet	15	....		139-703L1
62	D38999/33J15R		Cover	1	....		139-703L1
63	ED300AIS;XPDR		Decal	1	....		139-703L1
64	ED300J375		Decal	1	....		139-703L1
65	ED300J376A		Decal	1	....		139-703L1
66	ED300J377		Decal	1	....		139-703L1
67	M85049/95-16A-A		Flange	1	....		139-703L1
68	MS21042L04		Nut	4	....		139-703L1
69	MS21043L3	MS21043-3	Nut	15	....		139-703L1
70	MS25281-R12		Clamp	11	....		139-703L1
71	MS25281-R6		Clamp	6	....		139-703L1
72	MS25281-R7		Clamp	1	....		139-703L1
73	MS90376-10R		Cap	2	....		139-703L1
74	MS90376-12R		Cap	1	....		139-703L1
75	MS90376-14R		Cap	1	....		139-703L1
76	MS90376-20Y		Cap	1	....		139-703L1
77	MS9592-016		Bracket	1	....		139-703L1
78	MS9592-027		Bracket	1	....		139-703L1
79	NAS1149D0332J		Washer	11	....		139-703L1
80	NAS1149DN216J		Washer	8	....		139-703L1
81	NAS1149DN416J		Washer	4	....		139-703L1
82	NAS1190E3P18AK		Screw	1	....		139-703L1
83	NAS1190E3P20AK		Screw	1	....		139-703L1
84	NAS1190E3P22AK		Screw	1	....		139-703L1
85	NAS1190E3P23AK		Screw	1	....		139-703L1
86	NAS1190E3P24AK		Screw	2	....		139-703L1
87	NAS1190E3P26AK		Screw	1	....		139-703L1
88	NAS1190E3P6AK		Screw	1	....		139-703L1
89	NAS1802-04-7		Screw	8	....		139-703L1
90	NAS1802-3-26		Screw	2	....		139-703L1
91	NAS1802-3-6		Screw	1	....		139-703L1
92	NAS1802-3-8		Screw	3	....		139-703L1
93	NAS43DD3-30N		Spacer	1	....		139-703L1

#	P/N	ALTERNATIVE P/N	DESCRIPTION	Q.TY	LVL	NOTE	LOG P/N
94	NAS43DD3-40N		Spacer	6	....		139-703L1
95	NAS43DD3-50N		Spacer	4	....		139-703L1
96	NAS43DD3-56N		Spacer	1	....		139-703L1
97	NAS43DD3-60N		Spacer	1	....		139-703L1
98	NAS43DD3-64N		Spacer	5	....		139-703L1
99	NAS43DD3-75N		Spacer	2	....		139-703L1
100	A556A-T20		Wire	2,5 m	....		139-703L1
101	MS25036-149		Electrical contact	1	....		139-703L1
102	M39029/56-352		Electrical contact	1	....		139-703L1
103	ED300CB260		Decal	1	....		139-703L1
104	MS3320-5		Circuit Breaker	1	....		139-703L1
105	3G2490LXXXXX		Integrally lighted auxiliary C/B panel	1	....	(2)	

Refer also to IPD for the spares materials required to comply with the AMP DMs referenced in the accomplishment instructions.

## A.2 CONSUMABLES

The following consumable materials, or equivalent, are necessary to accomplish this Service Bulletin:

#	SPEC./LHD CODE NUMBER	DESCRIPTION	Q.TY	NOTE	PART
106	MMM-A-132, Type II, Class 2 199-05-002 Type I, Class 2	Adhesive EA9309.3NA(C021)	AR	(3)	-
107	MMM-A-132, Type I, Class 3 199-05-002 Type II, Class 2	Adhesive EA934NA (C057)	AR	(3)	-
108	MIL-S-8802, Type II, class B2	Sealing compound Proseal 890B2 (C153)	AR	(3)	-
109	SAE AMS-S-8802B Type II Class B-4	Sealing compound PR1422 (C020)	AR	(3)	-
110	AWTR033	Glass dry fabric cloth HexForce 20749 1200 (C931)	AR	(3)	-
111	Commercial / 199-50-002 Type I	Araldite resin LY5138-2	AR	(3)	-
112	Commercial / 199-50-002 Type II	Hardener HY5173	AR	(3)	-

Refer also to AMDI for the consumable materials required to comply with the AMP DMs referenced in the accomplishment instructions.

## A.3 LOGISTIC MATRIX

In order to apply this Service Bulletin, the following Logistic P/N can be ordered in accordance with the applicable notes:

LOGISTIC P/N	Q.TY (PER HELO)	NOTE	PART
139-703L1	1		-
3G2490LXXXXX	1	(2)	-

## NOTES

(1) Kit AIS transponder P/N 7001-000-131 is composed by:

- P/N 7000-119-121 AIS transponder product;
- P/N 7000-119-109 configuration and monitoring tool CD;

- P/N 7000-119-028 installation manual.
- (2) The P/N is not properly completed because it is depending on the helicopter configuration. Customers must contact Product Support Engineering ([engineering.support.lhd@leonardocompany.com](mailto:engineering.support.lhd@leonardocompany.com)) to request the new auxiliary CB panel at least three months in advance from the scheduled application of this Service Bulletin.
- (3) Item to be procured as local supply.

**B. SPECIAL TOOLS**

The following special tools, or equivalent, are necessary to accomplish this Service Bulletin:

#	P/N	DESCRIPTION	Q.TY	NOTE	PART
113	3G5310H25813A005A	Rework template	1	(B1)	I

Refer to ITEP for the special tools required to comply with the AMP DM referenced in the accomplishment instructions.

**SPECIAL TOOLS NOTE**

(B1) Please contact Leonardo Helicopters Division order administration to request the tools supply on loan. As soon as the present Service Bulletin is implemented the tools supplied on loan shall be promptly returned to Leonardo Helicopters Division.

**C. INDUSTRY SUPPORT INFORMATION**

Customization.



### **3. ACCOMPLISHMENT INSTRUCTIONS**

#### **GENERAL NOTES**

- a) Place an identification tag on all components that are re-usable, including the attaching hardware that has been removed to gain access to the modification area and adequately protect them until their later re-use.
  - b) Shape the cables in order to prevent interference with the structure and the other existing installations, using where necessary suitable lacing cords.
  - c) Exercise extreme care during drilling operations to prevent instruments, cables and hoses damage.
  - d) After drilling, remove all swarf and sharp edges. Apply on bare metal a light film of primer unless the hole is used for ground connection.
  - e) During the installation of bonding braids or components requiring grounding, clean the surface structure in order to obtain a good ground contact.
  - f) Let adhesive cure at room temperature for at least 24 hours unless otherwise specified.
  - g) Exposed thread surface and nut must be protected using a layer of tectyl according to MIL-C-16173 grade I.
  - h) All lengths are in mm.
1. In accordance with AMP DM 39-A-00-20-00-00A-120A-A, prepare the helicopter on ground for a safe maintenance. Disconnect the battery, all electrical power sources and/or the external power supply.
  2. In accordance with AMP DM 39-A-06-41-00-00A-010A-A and with reference to Figures 1, 10 and 18, remove all external panels, internal panels and internal liners as required to gain access to the area affected by the installation.
  3. With reference to Figures 1 thru 9, perform the structural provision installation for AIS transponder P/N 3G5310A25813 as described in the following procedure:
    - 3.1 With reference to Figure 3 Section B-B, remove the bracket assy P/N 3P5315A12531. Retain relevant fixing hardware for later reuse.

- 3.2 With reference to Figure 3 Section B-B, install the bracket P/N 3P5315A12532 with the fixing hardware previously removed.

**NOTE**

With reference to Figure 3, different positions must be used for insert installation on helicopters S/N 31403, 31413, 31420, 31427, 31434, 31439, 31448, 31469, 31481, 31489, 31521, 31526 and 31528.

- 3.3 In accordance with CSRP DM CSRP-A-51-42-00-00A-720A-D and with reference to Figure 3 Section L-L and Section H-H, install n°4 inserts P/N NAS1836C08-13M by means of adhesive EA934NA (C057) in the indicated positions on the forward floor P/N 3P5340A03531.

**NOTE**

Perform the following step 3.4 only if the cutout is not already present.

- 3.4 With reference to Figure 5 Detail M, perform indicated cut out on the upper panel.
- 3.5 With reference to Figure 4 View F and Figure 5 Detail T, remove existing insert from the indicated position on the upper panel and fill the hole with adhesive EA934NA (C057).
- 3.6 In accordance with CSRP DM CSRP-A-51-42-00-00A-720A-D and with reference to Figure 4 View F and Figure 5 Section U-U, install an insert P/N NAS1836C08-13M by means of adhesive EA934NA (C057) in the indicated position on the upper panel.
- 3.7 With reference to Figure 5 Section G-G, drill n°2 holes Ø 4.20 in the indicated positions on the left longeron P/N 3P5340A11951.
- 3.8 With reference to Figure 5 Section G-G, install n°2 anchor nuts P/N MS21069-08 by means of n°4 rivets P/N MS20426AD3.
- 3.9 With reference to Figure 6 View D, install the nut plate P/N A423A3C8 by means of n°2 rivets P/N MS20470AD4 in the indicated position on the lower frame STA 7200 P/N 3P5340A10453.
- 3.10 With reference to Figure 6 View D and View E, install the nut plate P/N A423A3C8 by means of n°2 rivets P/N MS20470AD4 in the indicated position on the lower frame STA 8150 P/N 3P5340A10850.
- 3.11 In accordance with AMP DM 39-A-06-41-00-00A-010A-A, remove the access panels 313AL and 360DL.
- 3.12 With reference to Figure 10 and 11, install the rework template P/N 3G5310H25813A005A as described in the following procedure:

- 3.12.1 With reference to Figure 11 View B, fix the rework template in the indicated positions 1 and 2 (panel 360DL fixing points).
- 3.12.2 With reference to Figure 11 View C, fix the rework template in the indicated positions 3 and 4 (panel 313AL fixing points).
- 3.12.3 With reference to Figure 10 View A and Figure 7 Detail C, adjust the position of the rework template as indicated to make the correct cut-out.
- 3.13 With reference to Figure 10 View A and Figure 7 Detail C, countermark the cut-out as required.
- 3.14 With reference to Figure 7 Detail C and Figure 9 Section Cut S-S, perform indicated cut out on the end cone RH panel assy P/N 3G5351A06233.
- 3.15 With reference to Figure 10 and 11, remove the rework template P/N 3G5310H25813A005A from the helicopter.
- 3.16 With reference to Figure 9 Schematic Section, seal all around the cut out edges by means of adhesive EA934NA (C057).
- 3.17 Prepare a compound mixing 100 parts by weight of araldite resin LY5138-2 and 23 parts by weight of hardener HY5173.
- 3.18 With reference to Figure 9 Schematic Section, apply on the cut out edges n°2 plies of fiberglass fabric 20749-1200 (C931) soaked with the previously prepared compound and check that the adhesive cures.
- 3.19 In accordance with CSRP DM CSRP-A-51-42-00-00A-720A-D and with reference to Figure 8 Section Cut R-R, install the plate P/N 3G5316A50951 and n°2 inserts P/N 999-5000-30-109 by means of adhesive EA934NA (C057) in the indicated positions on the end cone RH panel assy P/N 3G5351A06233 according to antenna support assy P/N 3G5316A50731.
- 3.20 With reference to Figure 7 Detail C and Figure 8 Section Cut R-R, install the antenna support assy P/N 3G5316A50731 by means of n°2 screws P/N MS27039-1-06 and n°2 washers P/N NAS1149D0332K . Seal all around using Proseal 890B2 (C153).

**NOTE**

Perform the following step 3.21 only if antenna E41 will  
not be installed immediately after.

- 3.21 With reference to Figure 7 View N, install the closure sheet P/N 3G5316A50851 by means of n°4 screws P/N MS27039-1-07 and n°4 washers P/N NAS1149D0332K on the antenna support assy P/N 3G5316A50731.
- 4. With reference to Figures 12 thru 19, Figures 24 and 25 wiring diagrams, perform the AIS transponder electrical provision P/N 4G3450A01413 as described on following procedure:

- 4.1 With reference to Figure 14, at position n°1, install stud P/N A366A3E18C by means of adhesive EA9309.3NA (C021) and install clamp P/N°AW001CB04H, spacer P/N°NAS43DD3-30N, washer P/N°NAS1149D0332J and nut P/N°MS21043L3.
- 4.2 With reference to Figure 14, at positions n°2 and n°3, install n°2 studs P/N A366A3E22C by means of adhesive EA9309.3NA (C021) and install n°2 clamps P/N°MS25281-R6, n°2 spacers P/N°NAS43DD3-50N, n°2 grommets P/N°AW002FT102 and n°2 nuts P/N°MS21043L3.
- 4.3 With reference to Figure 14, at positions n°4-5-6, install n°3 spacers P/N°A631A02A and n°3 grommets P/N°AW002FT103.
- 4.4 With reference to Figure 15, at positions n°7-8-9-10, install n°4 supports P/N°AW001CL000A-X3 by means of adhesive EA9309.3NA (C021).
- 4.5 With reference to Figure 16, at position n°11, install stud P/N A366A3E12C by means of adhesive EA9309.3NA (C021) and install clamp P/N°AW001CB03H, washer P/N°NAS1149D0332J and nut P/N°MS21043L3.
- 4.6 With reference to Figure 16, at positions n°12-13-14, install n°3 studs P/N A366A3E12C by means of adhesive EA9309.3NA (C021) and install n°3 clamps P/N°MS25281-R6, n°3 grommets P/N°AW002FT102 and n°3 nuts P/N°MS21043L3.
- 4.7 With reference to Figure 16, at position n°15, install clamp P/N°AW001CB03H, washer P/N°NAS1149D0332J and screw P/N°NAS1802-3-8.
- 4.8 With reference to Figure 16, install adhesive rubber P/N° A236A03AB in the indicated position.
- 4.9 With reference to Figure 16, at position n°16, remove existing screw and install on existing hardware clamp P/N°MS25281-R6, spacer P/N°NAS43DD3-56N, grommet P/N°AW002FT102 and screw P/N°NAS1190E3P24AK.
- 4.10 With reference to Figure 17 View E-E, install adhesive rubber P/N° A236A03AB in the indicated position.
- 4.11 With reference to Figure 17, at position n°17, install support P/N AW001TL3A08T by means of adhesive EA9309.3NA (C021) and install clamp P/N°AW001CB03H, washer P/N°NAS1149D0332J and screw P/N°NAS1802-3-8.
- 4.12 With reference to Figure 17, at position n°18, install stud P/N A366A3E18C75 by means of adhesive EA9309.3NA (C021) and install bracket P/N°MS9592-027, clamp P/N°AW001CB04H, spacer P/N°NAS43DD3-40N, n°3 washers P/N°NAS1149D0332J, screw P/N°NAS1802-3-8 and n°2 nuts P/N°MS21043L3.

- 4.13 With reference to Figure 18, at position n°19, install on existing hardware clamp P/N°MS25281-R12, spacer P/N°NAS43DD3-64N, grommet P/N°AW002FT503 and screw P/N°NAS1190E3P24AK.
- 4.14 With reference to Figure 18, at position n°20, install on existing hardware clamp P/N°MS25281-R12, spacer P/N°NAS43DD3-64N, grommet P/N°AW002FT503 and screw P/N°NAS1190E3P26AK.
- 4.15 With reference to Figure 18, at position n°22, install on existing hardware clamp P/N°MS25281-R12, spacer P/N°NAS43DD3-64N, grommet P/N°AW002FT503 and screw P/N°NAS1802-3-26.
- 4.16 With reference to Figure 18, at position n°23, replace existing stud with stud P/N A366A3E30C by means of adhesive EA9309.3NA (C021) and install clamp P/N°MS25281-R12, spacer P/N°NAS43DD3-64N and grommet P/N°AW002FT503.
- 4.17 With reference to Figure 18, at positions n°21-24-25-27, install n°4 spacers P/N°A631A01A and n°4 grommets P/N°AW002FT103.
- 4.18 With reference to Figure 18, at position n°26, install on existing hardware clamp P/N°MS25281-R12, spacer P/N°NAS43DD3-60N, grommet P/N°AW002FT503 and screw P/N°NAS1190E3P22AK.
- 4.19 With reference to Figure 18, at position n°28, install on existing hardware clamp P/N°MS25281-R12, spacer P/N°NAS43DD3-64N, grommet P/N°AW002FT503 and screw P/N°NAS1190E3P23AK.
- 4.20 With reference to Figure 18, remove rail P/N°001751-102-00 and install rail P/N°A522A04A by means of existing hardware.
- 4.21 With reference to Figure 18, install TB311/3 terminal board P/N°A593A-A04, TB311/2 terminal board P/N°A593A-A01, label P/N°A524A3A-A and label P/N°A524A2A-A on the rail previously installed.
- 4.22 With reference to Figure 19, at positions n°29-30-31, install n°3 studs P/N A366A3E22C75 by means of adhesive EA9309.3NA (C021) and install n°3 clamps P/N°MS25281-R12, n°3 spacers P/N°NAS43DD3-40N, n°3 grommets P/N°AW002FT503 and n°3 nuts P/N°MS21043L3.
- 4.23 With reference to Figure 19, at positions n°32, install stud P/N A366A3E32C by means of adhesive EA9309.3NA (C021) and install clamp P/N°MS25281-R7, spacer P/N°NAS43DD3-75N, grommet P/N°AW002FT102, washer P/N°NAS1149D0332J and nut P/N°MS21043L3.

- 4.24 With reference to Figure 19, at positions n°33, install stud P/N A366A3E32C by means of adhesive EA9309.3NA (C021) and install clamp P/N°AW001CB04H, spacer P/N°NAS43DD3-75N, washer P/N°NAS1149D0332J and nut P/N°MS21043L3.
- 4.25 With reference to Figure 19, install adhesive rubber P/N° A236A03AB in the indicated position.
- 4.26 With reference to Figure 19, at position n°34, install stud P/N A388A3E12C75 by means of adhesive EA9309.3NA (C021) and install bracket P/N°MS9592-016, clamp P/N°AW001CB04H, n°2 washers P/N°NAS1149D0332J, screw P/N°NAS1190E3P6AK, screw P/N° NAS1802-3-6 and nut P/N°MS21043L3.
- 4.27 With reference to Figure 19, at position n°35, install support P/N AW001CL000A-X3 by means of adhesive EA9309.3NA (C021).
- 4.28 With reference to Figure 19, at position n°36, install on existing hardware clamp P/N°AW001CB04H, spacer P/N°NAS43DD3-50N and screw P/N°NAS1190E3P20AK.
- 4.29 With reference to Figure 19, at position n°37, install on existing hardware clamp P/N°AW001CB04H, spacer P/N°NAS43DD3-50N and screw P/N°NAS1190E3P18AK.
- 4.30 With reference to Figure 19, at position n°38-39, install on existing hardware n°2 clamps P/N°MS25281-R12, n°2 spacers P/N°NAS43DD3-40N and n°2 grommets P/N°AW002FT503.

#### NOTE

Use edging P/N°A236A on metallic edges which can damage cable assemblies and where abrasion may occur.

Use braided tubing P/N°A582A where cable assemblies chafing or contact with structure may occur.

Secure the cables by means of previously installed fixing hardware and existing hardware. If necessary replace existing clamps with suitable clamps.

- 4.31 With reference to Figures 12 thru 19, lay down the following cable assemblies following the existing route unless otherwise indicated on the figures:
- P/N°3G9B01A32301 AIS transponder C/A (B1A323);
  - P/N°3G9C01A23001 AIS transponder C/A (C1A230);
  - P/N°3G9C02A21701 AIS transponder C/A (C2A217);
  - P/N°3G9C03A20401 AIS transponder C/A (C3A204);

- P/N°3G9C03C20001 AIS transponder C/A (C3C200);
  - P/N°3G9D03A20202 AIS transponder C/A (D3A202);
- 4.32 With reference to Figure 13 and Figure 24 Wiring Diagram, perform the electrical connections of cable assy B1A323 between circuit breaker panel connector PL1P1 and sectioning connector J213.
- 4.33 With reference to Figures 14, 15, 18, 21 and Figure 24 Wiring Diagram, perform the electrical connections of cable assy C1A230 between AIS transponder connectors A163P1 and A163P2, sectioning connector P213, terminal boards TB305 and TB315.
- 4.34 With reference to Figures 14, 15, 18, 21 and Figure 24 Wiring Diagram, perform the electrical connections of cable assy C2A217 between AIS transponder connector A163P1, sectioning connector J375, terminal boards TB311/2 and TB311/3.
- 4.35 With reference to Figures 14 thru 17, 19, 21 and Figure 25 Wiring Diagram, perform the electrical connections of cable assy C3A204 between AIS transponder connector A163P4 and sectioning connector P377.
- 4.36 With reference to Figures 14, 15, 18, 21 and Figure 25 Wiring Diagram, perform the electrical connections of cable assy C3C200 between AIS transponder connector A163P3 and sectioning connector P376A.
- 4.37 With reference to Figure 19 and Figure 25 Wiring Diagram, perform the electrical connections of cable assy D3A202 between VHF antenna connector E41P1 and sectioning connector J377.
- 4.38 With reference to Figure 15 View A-A, fix the connector J375 to the bracket by means of flange P/N°M85049/95-16A-A, n°4 washers P/N°NAS1149DN416J and n°4 screws P/N°NAS1802-04-7.
- 4.39 In accordance with AMP DM 39-A-11-00-01-00A-720A-A and with reference to Figure 15 View A-A, install decal P/N°ED300J375 and decal P/N°ED300AIS;XPDR in an area adjacent to connector J375.
- 4.40 With reference to Figure 15 View A-A, install dust cup P/N°D38999/33J15R on connector J375.
- 4.41 With reference to Figure 18 and Figure 25 Wiring Diagram, connect connector J376A to the connector P376.
- 4.42 In accordance with AMP DM 39-A-11-00-01-00A-720A-A and with reference to Figure 18, install n°2 decals P/N°ED300J376A in an area adjacent to connector J376A.

- 4.43 With reference to Figure 19, fix the connector J377 to the bracket by means of n°4 washers P/N°NAS1149DN216J, n°4 nuts P/N°MS21042L04 and n°4 screws P/N°NAS1802-04-6.
- 4.44 In accordance with AMP DM 39-A-11-00-01-00A-720A-A and with reference to Figure 19, install decal P/N°ED300J377 in an area adjacent to connector J377.
- 4.45 With reference to Figure 19 and Figure 25 Wiring Diagram, connect connector P377 to the connector J377.

**NOTE**

Customer must contact AW139 PSE at least 3 months in advance of embodiment date of this Service Bulletin in order to collect the exact W/D applicable to helicopter configuration.

- 4.46 In accordance with AMP DM 39-A-24-91-04-00A-920A-K remove from the Overhead C/B panel the existing integrally-lighted panel and install the new integrally-lighted panel P/N 3G2490LXXXXX.
- 4.47 Install circuit breaker P/N MS3320-5 in the indicated position on the new integrally-lighted panel P/N 3G2490LXXXXX; apply decal P/N ED300CB260 in an adjacent area.
- 4.48 With reference to Figure 24 Wiring Diagram, perform the electrical connection between pin 2 of CB260 and pin J of connector PL1J1 by means of wire A556A-T20. Use electrical contact P/N MS25036-149 for pin 2 of CB260 and electrical contact P/N M39029/56-352 for pin J of PL1J1.
- 4.49 With reference to Figure 24 Wiring Diagram, perform the electrical connection between pin 1 of CB260 and 28V DC NON ESS BUS 2 W21B.
- 4.50 Perform a pin to pin continuity check of all the electrical connections made.

**NOTE**

Perform the following steps 4.51 thru 4.54 only if AIS transponder A163 will not be installed immediately after.

- 4.51 With reference to Figure 15 Detail D and Detail C, protect the connector A163P1 by means of protective cap P/N MS90376-20Y, nomex fibre P/N A582A and tie-strap P/N 900004953. Stow connector on the electrical cable support by means of appropriate cable tie.
- 4.52 With reference to Figure 15 Detail D and Detail B, protect the connector A163P2 by means of protective cap P/N MS90376-12R, nomex fibre P/N A582A and tie-strap P/N 900004953. Stow connector on the electrical cable support by means of appropriate cable tie.



- 4.53 With reference to Figure 15 Detail D and Detail B, protect the connector A163P3 by means of protective cap P/N MS90376-10R, nomex fibre P/N A582A and tie-strap P/N 900004953. Stow connector on the electrical cable support by means of appropriate cable tie.
- 4.54 With reference to Figure 15 Detail D and Detail B, protect the connector A163P4 by means of protective cap P/N MS90376-14R, nomex fibre P/N A582A and tie-strap P/N 900004953. Stow connector on the electrical cable support by means of appropriate cable tie.

**NOTE**

Perform the following step 4.55 only if antenna E41 will not be installed immediately after.

- 4.55 With reference to Figure 19, protect the connector E41P1 by means of protective cap P/N MS90376-10R, nomex fibre P/N A582A and tie-strap P/N 900004953. Stow connector on the electrical cable support by means of appropriate cable tie.
- 5. With reference to Figures 20 thru 23, perform the AIS transponder equipment installation P/N 4G3450A01215 as described in the following procedure:

**NOTE**

If necessary, remove the AIS transponder connectors A163P1, A163P2, A163P3, A163P4 (Ref. Figure 20 Details B and C) and the VHF antenna connector E41P1 (Ref. Figure 21 Detail E) from the stowage positions.

- 5.1 With reference to Figure 22 View A-A, gain access to the overhead circuit breaker panel and remove n°2 lock rings P/N Y30700501 from the AIS XPDR breakers.
- 5.2 In accordance with AMP DM 39-B-34-59-01-00A-720A-K and with reference to Figure 21, install the AIS transponder product P/N 7000-119-121 by means of n°4 washers P/N NAS1149DN816J and n°4 screws P/N MS27039-0808.
- 5.3 In accordance with AMP DM 39-A-11-00-01-00A-720A-A and with reference to Figure 21, install decal P/N ED300A163 in an area adjacent to previously installed AIS transponder A163.
- 5.4 With reference to Figure 22 View D-D, if installed remove the closure sheet P/N 3G5316A50851 and relevant fixing hardware.
- 5.5 In accordance with AMP DM 39-E-34-59-02-00A-720A-K and with reference to Figure 23 View D-D, install the antenna P/N 16355 by means of n°4 screws P/N MS35207-265 on the antenna support assy P/N 3G5316A50731. Secure with lockwire P/N MS20995C41 and use sealing compound PR1422 (C020).

- 5.6 In accordance with AMP DM 39-A-11-00-01-00A-720A-A and with reference to Figure 23 View D-D, install decal P/N°ED300E41 in an area adjacent to previously installed antenna E41.
6. In accordance with AMP DM 39-B-34-59-00-00A-320A-K, perform the operation test of the AIS transponder system.
  7. In accordance with weight and balance changes, update the Chart A (see Rotorcraft Flight Manual, Part II, section 6).
  8. Return the helicopter to flight configuration and record for compliance with this Service Bulletin on the helicopter logbook.
  9. Gain access to My Communications section on Leonardo WebPortal and compile the "Service Bulletin Application Communication".

As an alternative, send the attached compliance form to the following mail box:

[engineering.support.lhd@leonardo.com](mailto:engineering.support.lhd@leonardo.com)

and (for North, Central and South America) also to:

[AWPC.Engineering.Support@leonardocompany.us](mailto:AWPC.Engineering.Support@leonardocompany.us)

**3G5310A25813**  
**STRUCTURAL PROVISION**  
**FOR AIS TRANSPONDER**

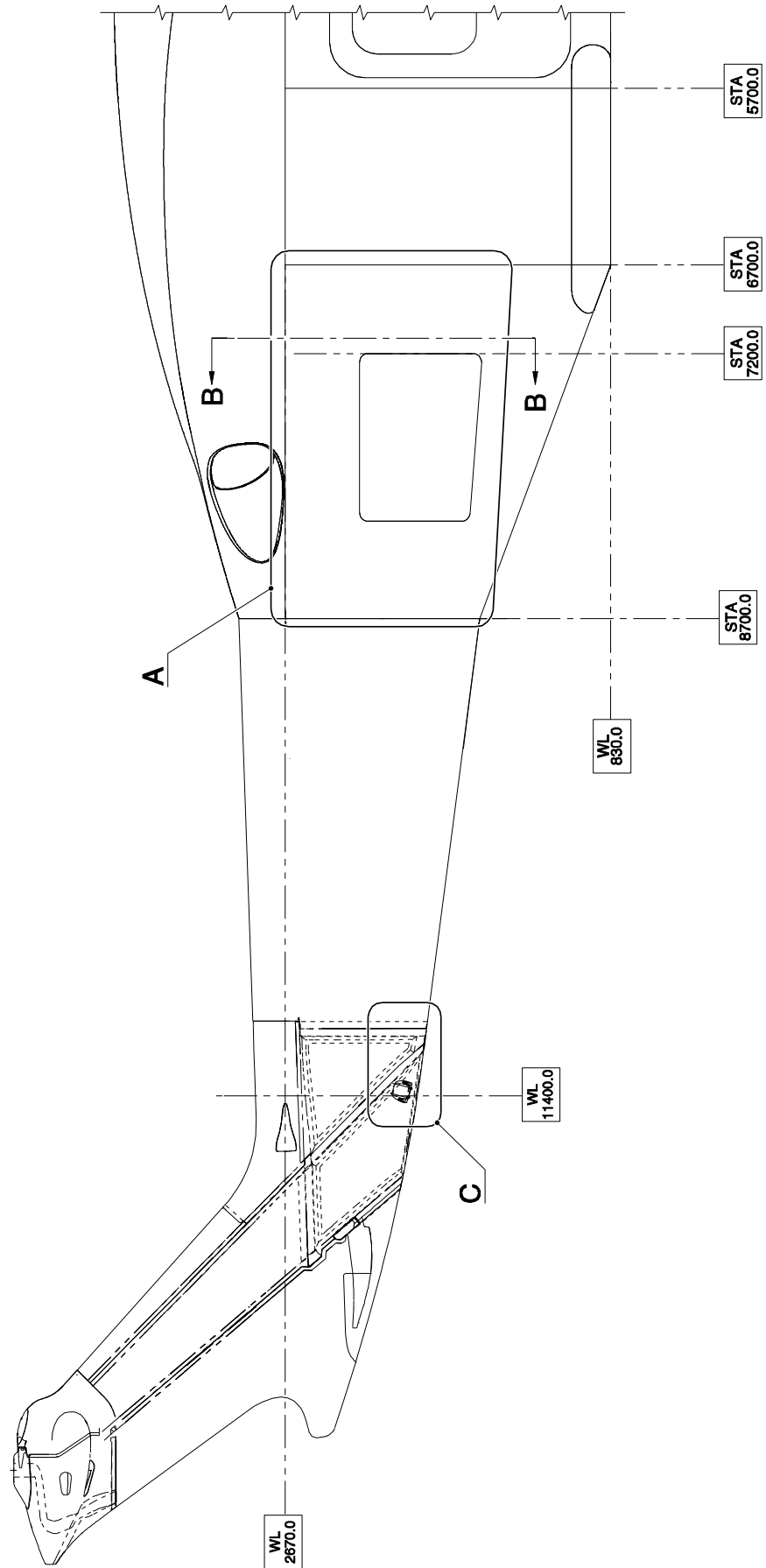

**Figure 1**

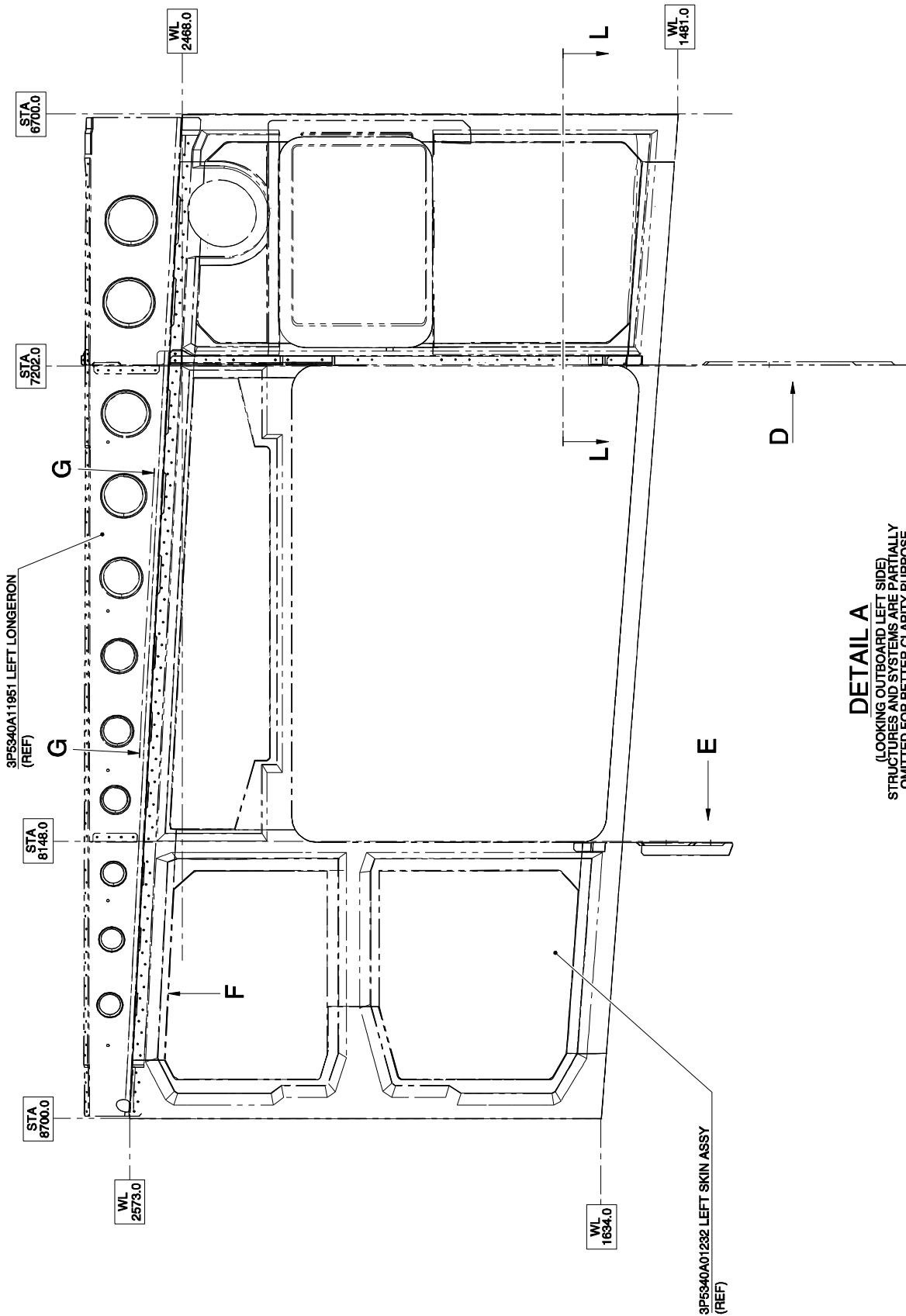

**DETAIL A**  
(LOOKING OUTBOARD LEFT SIDE)  
STRUCTURES AND SYSTEMS ARE PARTIALLY  
OMITTED FOR BETTER CLARITY PURPOSE

**Figure 2**

S.B. N°139-703 OPTIONAL  
DATE: October 17, 2023  
REVISION: /

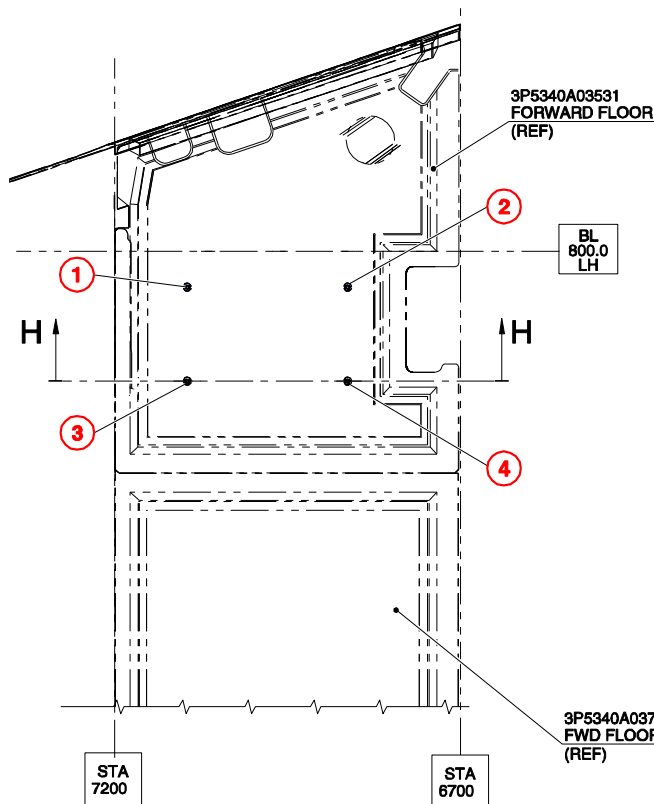
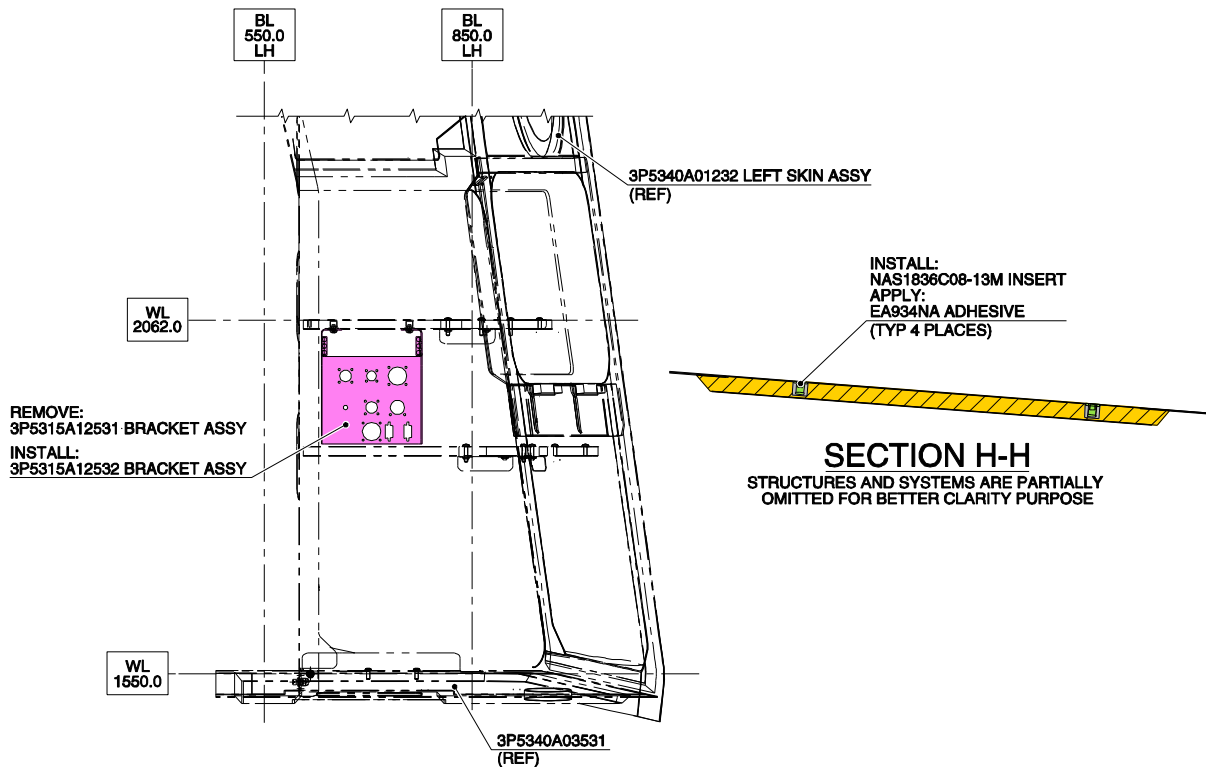

LOCATION NUMBER	STA	BL	WL	INSERT
①	7095.00	-748.00	1547.38	NAS1836C08-13M
②	6863.00	-748.00	1529.65	NAS1836C08-13M
③	7095.00	-612.00	1547.38	NAS1836C08-13M
④	6863.00	-612.00	1529.65	NAS1836C08-13M

**ALTERNATIVE LOCATIONS VALID ONLY FOR THE HELICOPTERS SPECIFIED IN PROCEDURE**

LOCATION NUMBER	STA	BL	WL	INSERT
①	7072.00	-755.50	1545.62	NAS1836C08-13M
②	6840.00	-755.50	1527.90	NAS1836C08-13M
③	7072.00	-619.50	1545.62	NAS1836C08-13M
④	6840.00	-619.50	1527.90	NAS1836C08-13M

Figure 3

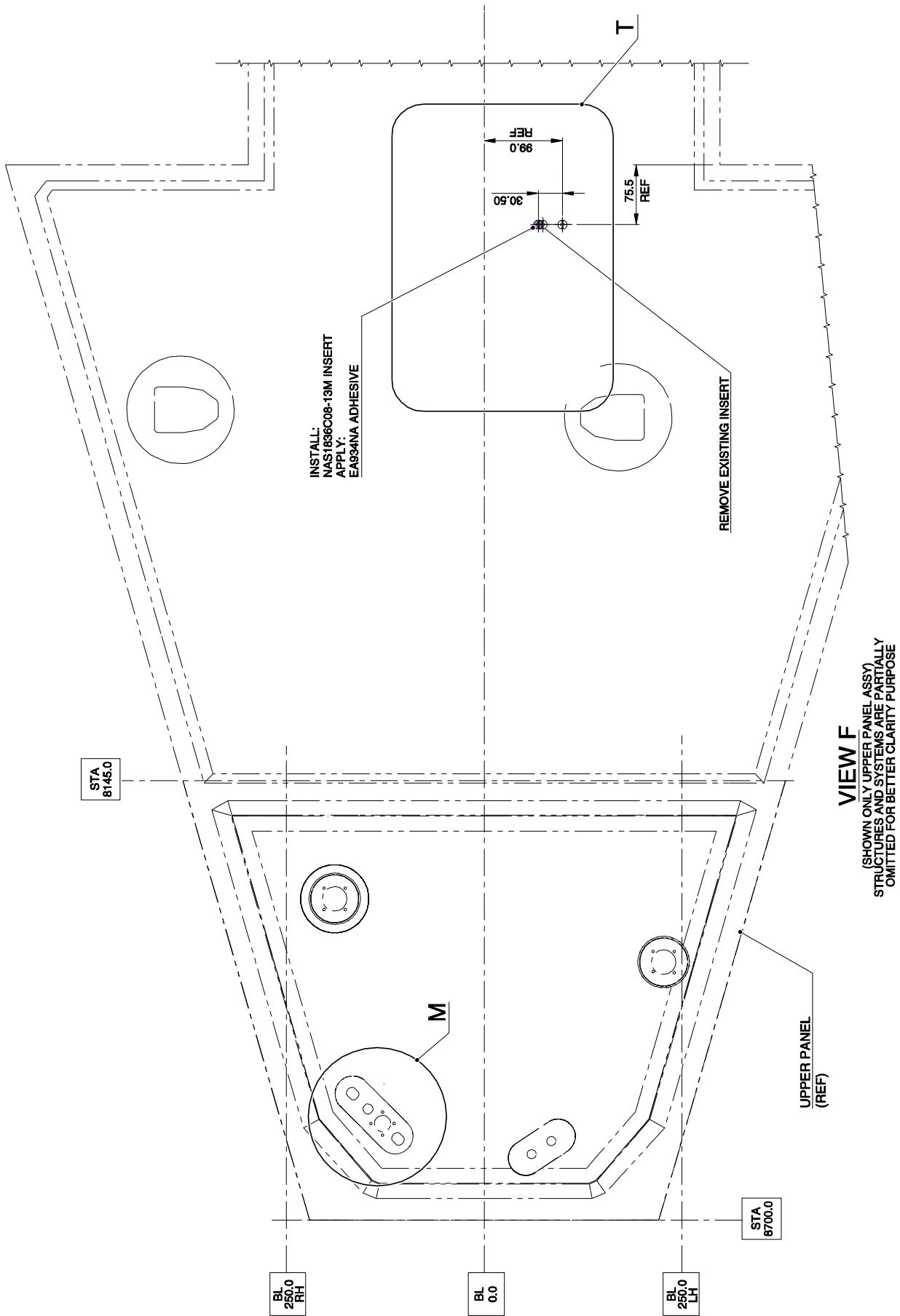

**Figure 4**

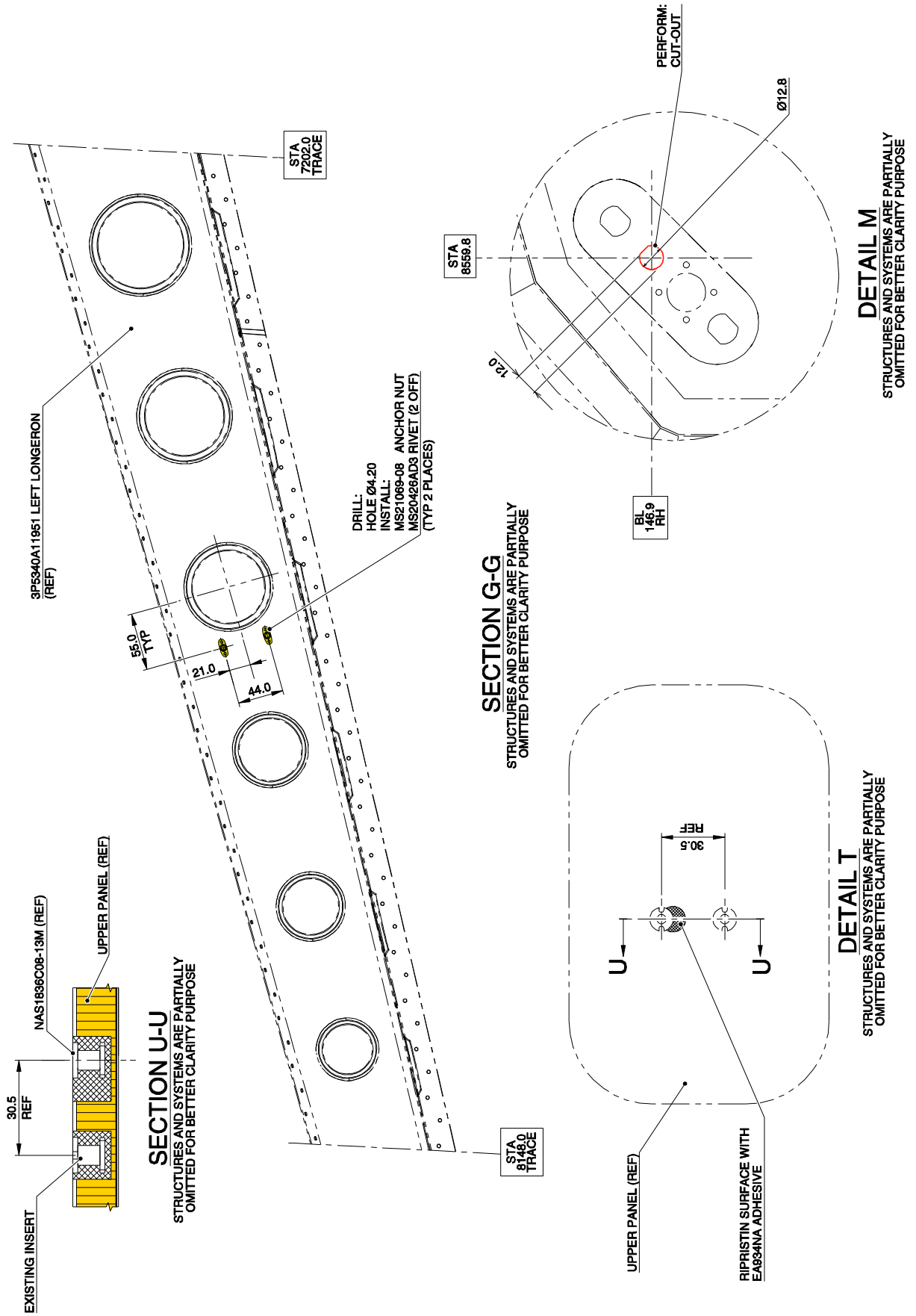
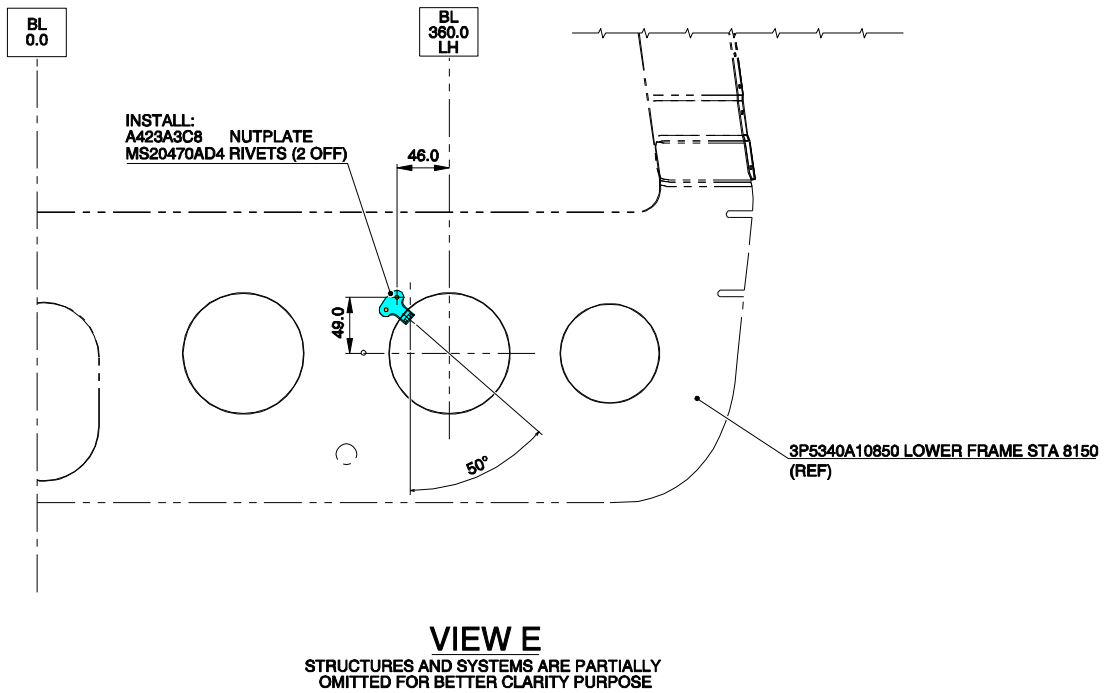
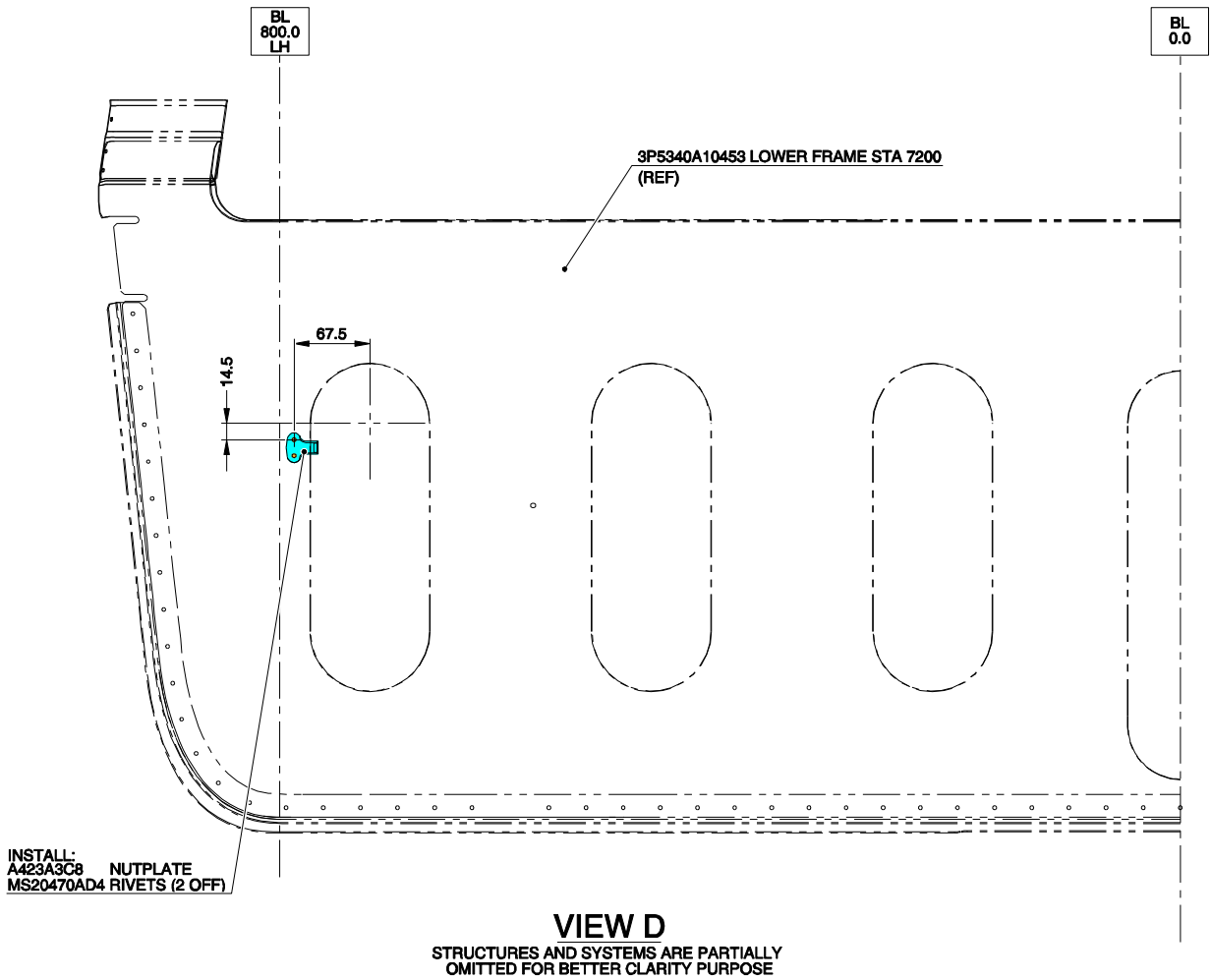

Figure 5



**Figure 6**

S.B. N°139-703 OPTIONAL  
DATE: October 17, 2023  
REVISION: /



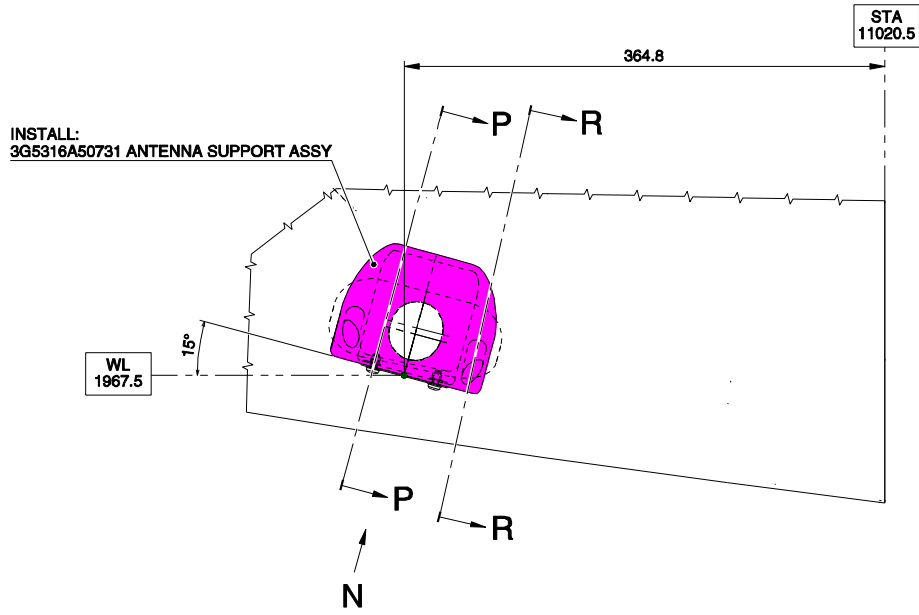

INSTALL:  
3G5316A50731 ANTENNA SUPPORT ASSY

WL  
1967.5

STA  
11020.5

**DETAIL C**

STRUCTURES AND SYSTEMS ARE PARTIALLY  
OMITTED FOR BETTER CLARITY PURPOSE

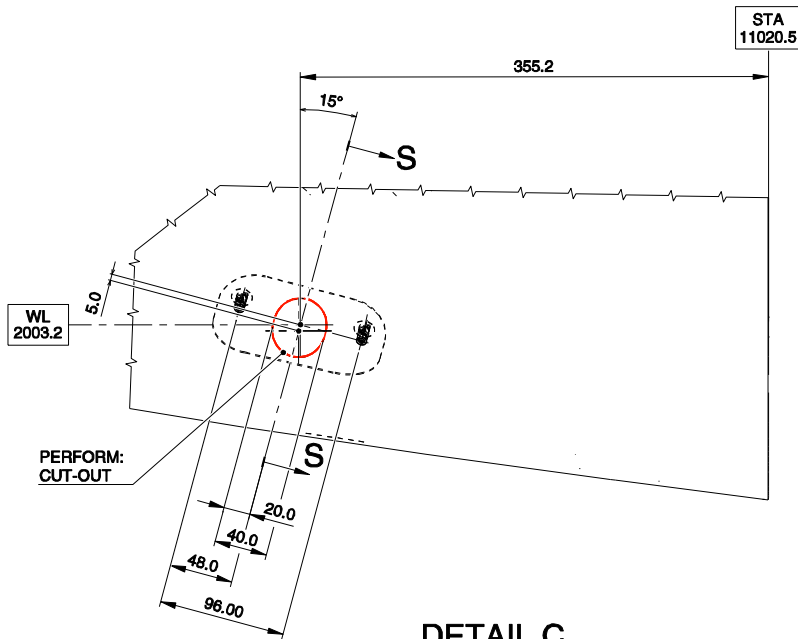

PERFORM:  
CUT-OUT

STA  
11020.5

**DETAIL C**

SUPPORT, STRUCTURES AND SYSTEMS ARE PARTIALLY  
OMITTED FOR BETTER CLARITY PURPOSE

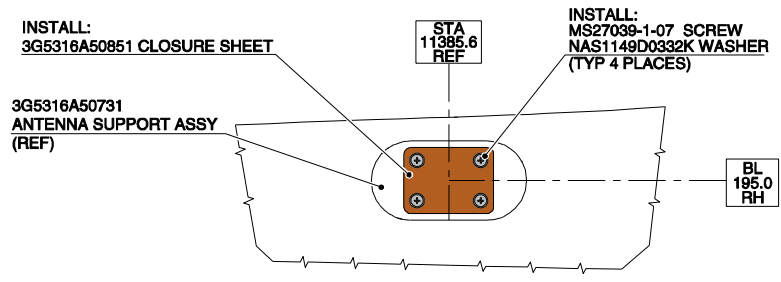

INSTALL:  
3G5316A50851 CLOSURE SHEET

STA  
11385.6  
REF

INSTALL:  
MS27039-1-07 SCREW  
NAS1149D0332K WASHER  
(TYP 4 PLACES)

3G5316A50731  
ANTENNA SUPPORT ASSY  
(REF)

BL  
195.0  
RH

**VIEW N**

(ROTATED 15° CCW)  
STRUCTURES AND SYSTEMS ARE PARTIALLY  
OMITTED FOR BETTER CLARITY PURPOSE

**Figure 7**

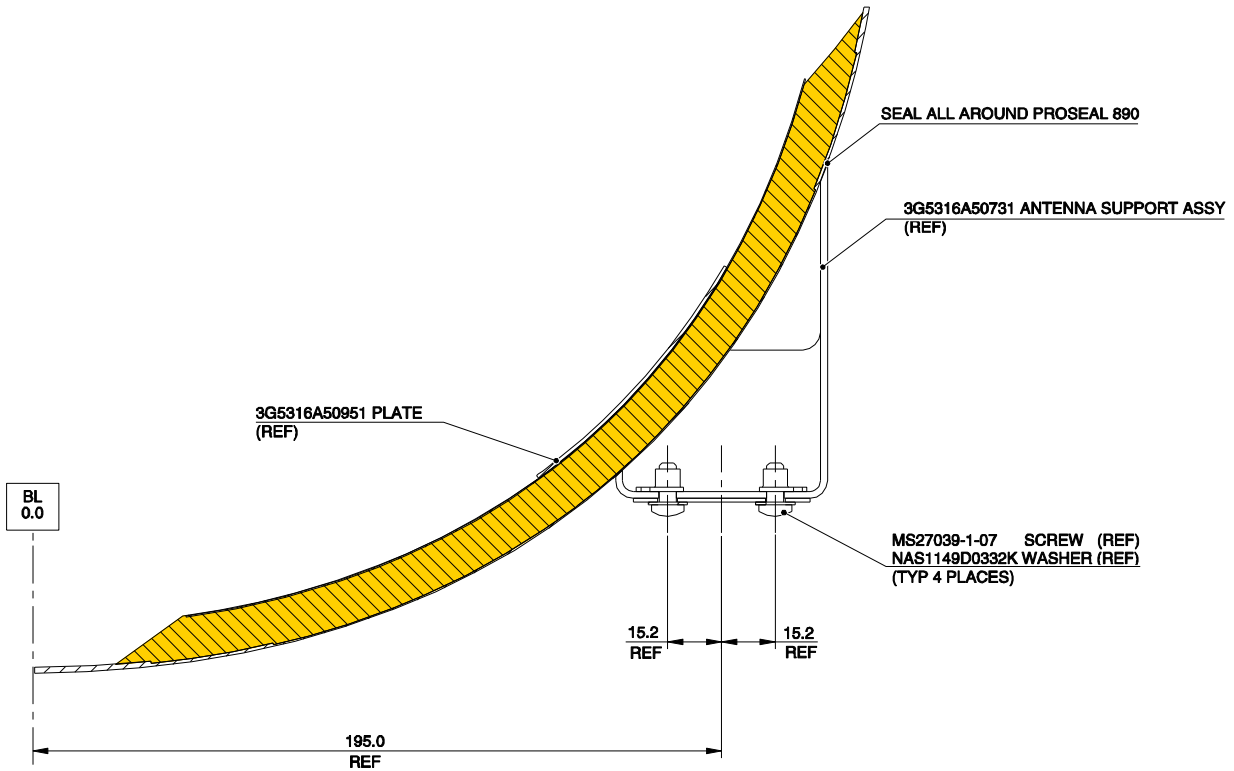

**SECTION CUT P-P**  
(ROTATED 15° CCW)  
STRUCTURES AND SYSTEMS ARE PARTIALLY  
OMITTED FOR BETTER CLARITY PURPOSE

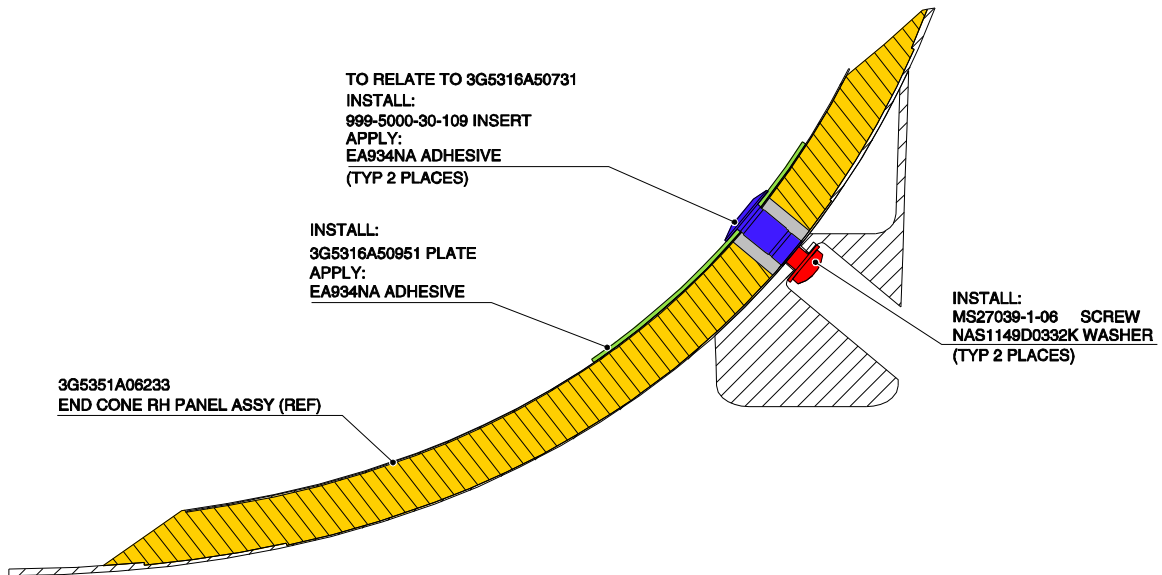

**SECTION CUT R-R**  
(ROTATED 12.63° CCW)  
STRUCTURES AND SYSTEMS ARE PARTIALLY  
OMITTED FOR BETTER CLARITY PURPOSE

**Figure 8**

S.B. N°139-703 OPTIONAL  
DATE: October 17, 2023  
REVISION: /

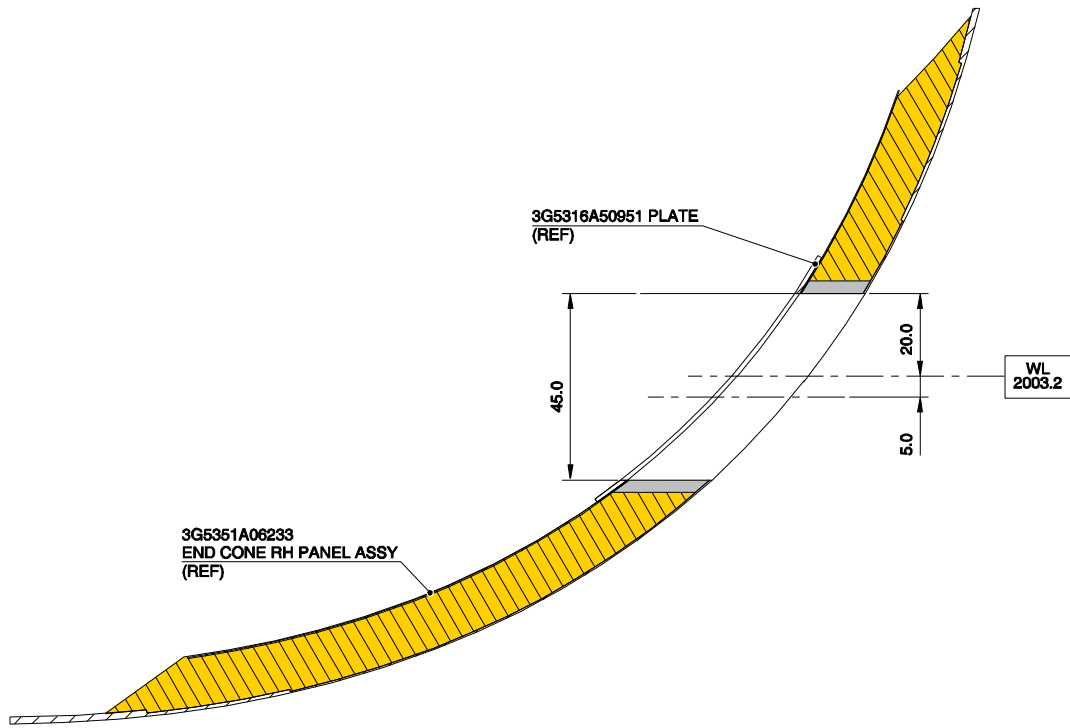

**SECTION CUT S-S**  
(ROTATED 15° CCW)  
STRUCTURES AND SYSTEMS ARE PARTIALLY OMITTED FOR BETTER CLARITY PURPOSE

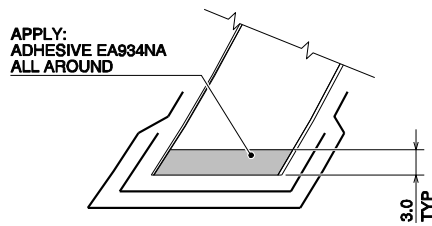

N° 2 PLYS  
FIBERGLASS FABRIC 20749-1200  
ARALDITE RESIN LY5138-2  
CATALYST HY5173 ALL AROUND

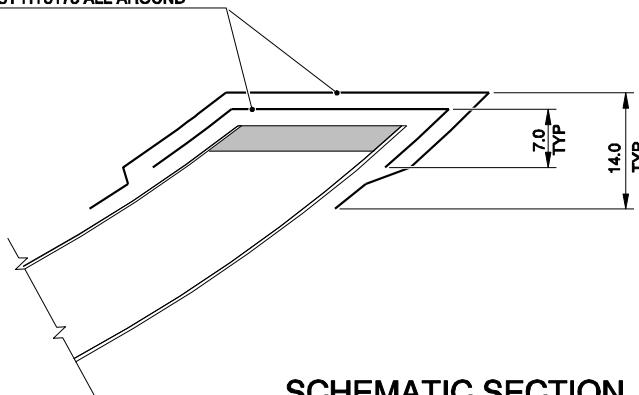

**SCHEMATIC SECTION**  
STRUCTURES AND SYSTEMS ARE PARTIALLY OMITTED FOR BETTER CLARITY PURPOSE

**Figure 9**

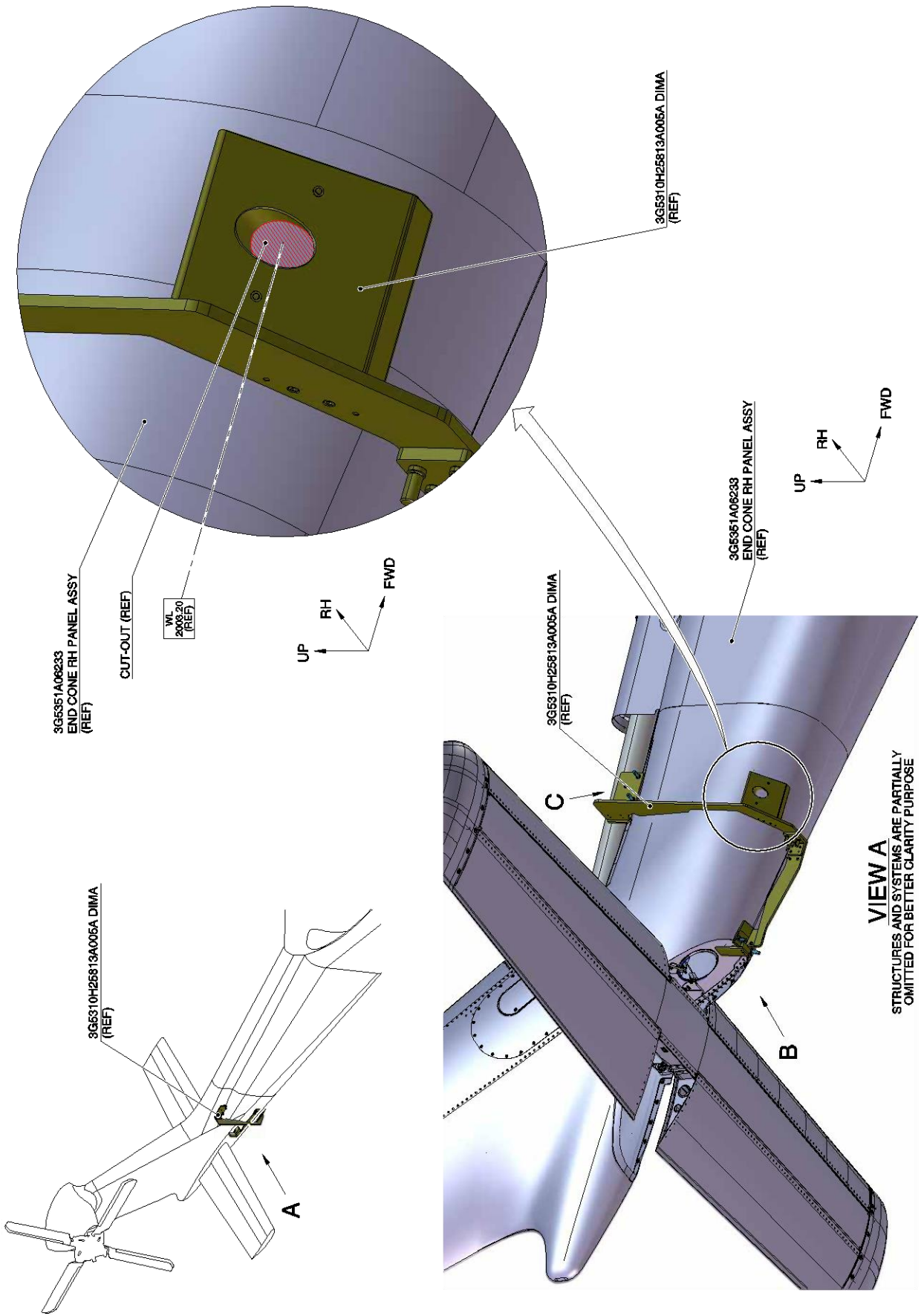

**Figure 10**

S.B. N°139-703 OPTIONAL  
DATE: October 17, 2023  
REVISION: /

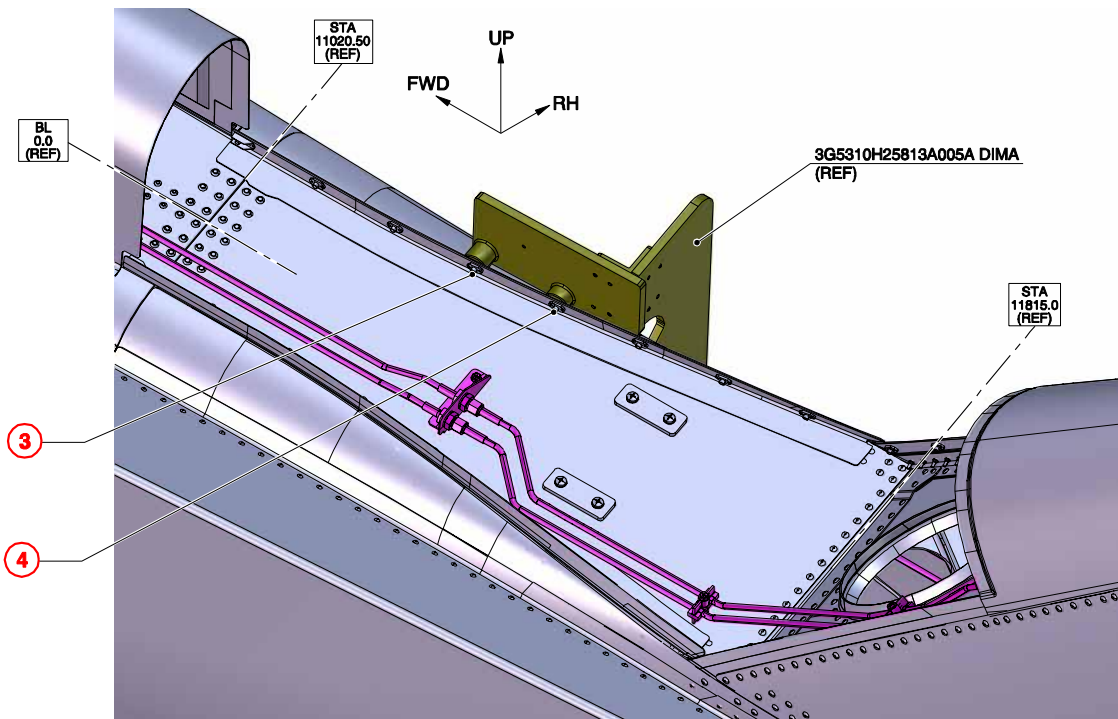
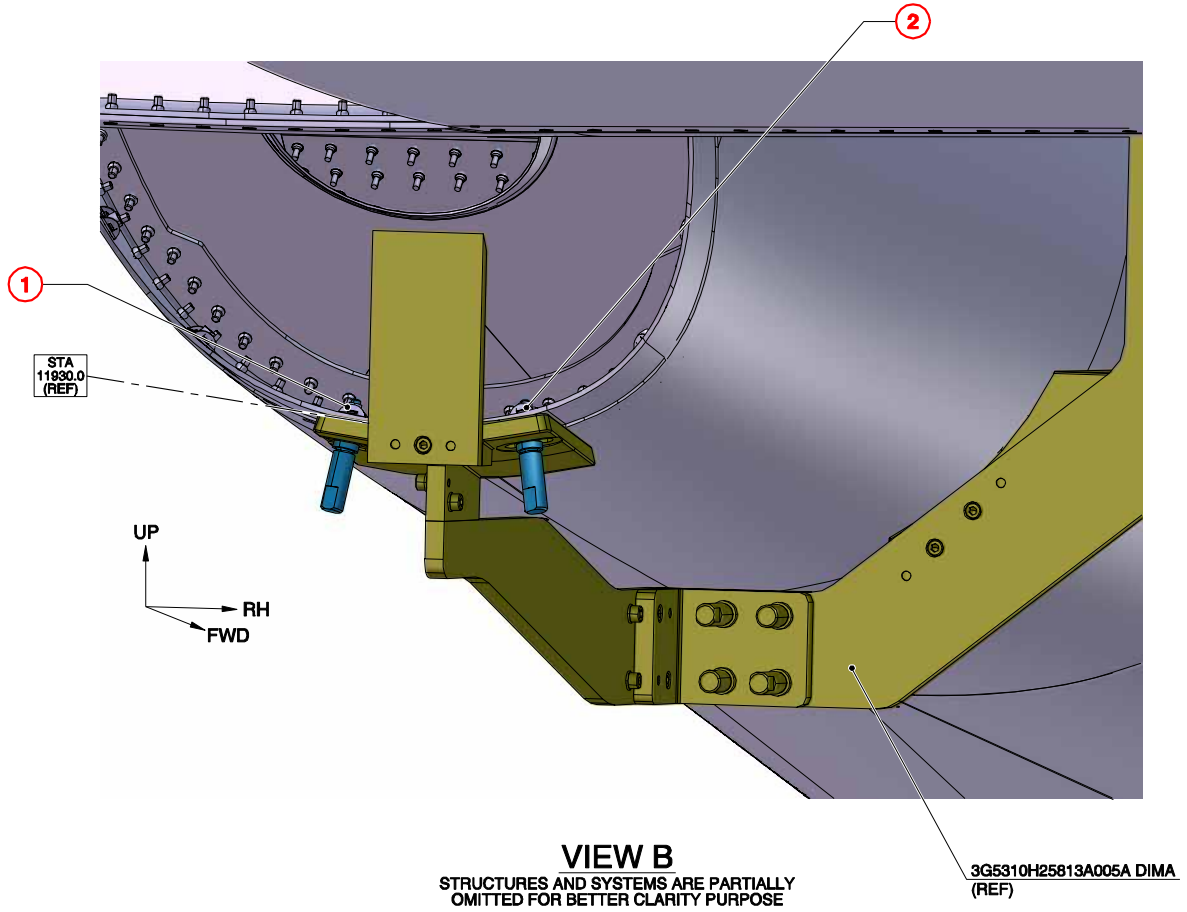

**Figure 11**

# 4G3450A01413 AIS TRANSPONDER ELECTRICAL PROVISION

ORIENTATION OF CABLE SUPPORTS  
DIAGRAM IS BASIC FOR ORIENTATION OF  
ALL CABLE SUPPORTS IN RELATIONSHIP  
TO AC AXIS SYSTEM.  
FOR ORIENTATION OFF SUPPORT SEE  
COORDINATE TABLE

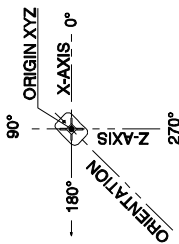

**XYZ** INDICATES WHERE GIVEN COORDINATES  
ARE LOCATED ON SUPPORT. SEE COORD. TABLE  
SUPPORT SHALL BE LOCATED WITHIN  $\pm 5$  MM OF  
GIVEN COORDINATES.  
ORIENTATION OF SUPPORT SHALL BE WITHIN  $\pm 5^\circ$  OF  
GIVEN VALUE UNLESS OTHERWISE NOTED.

A386A3E-C75  
A388A3E-C75

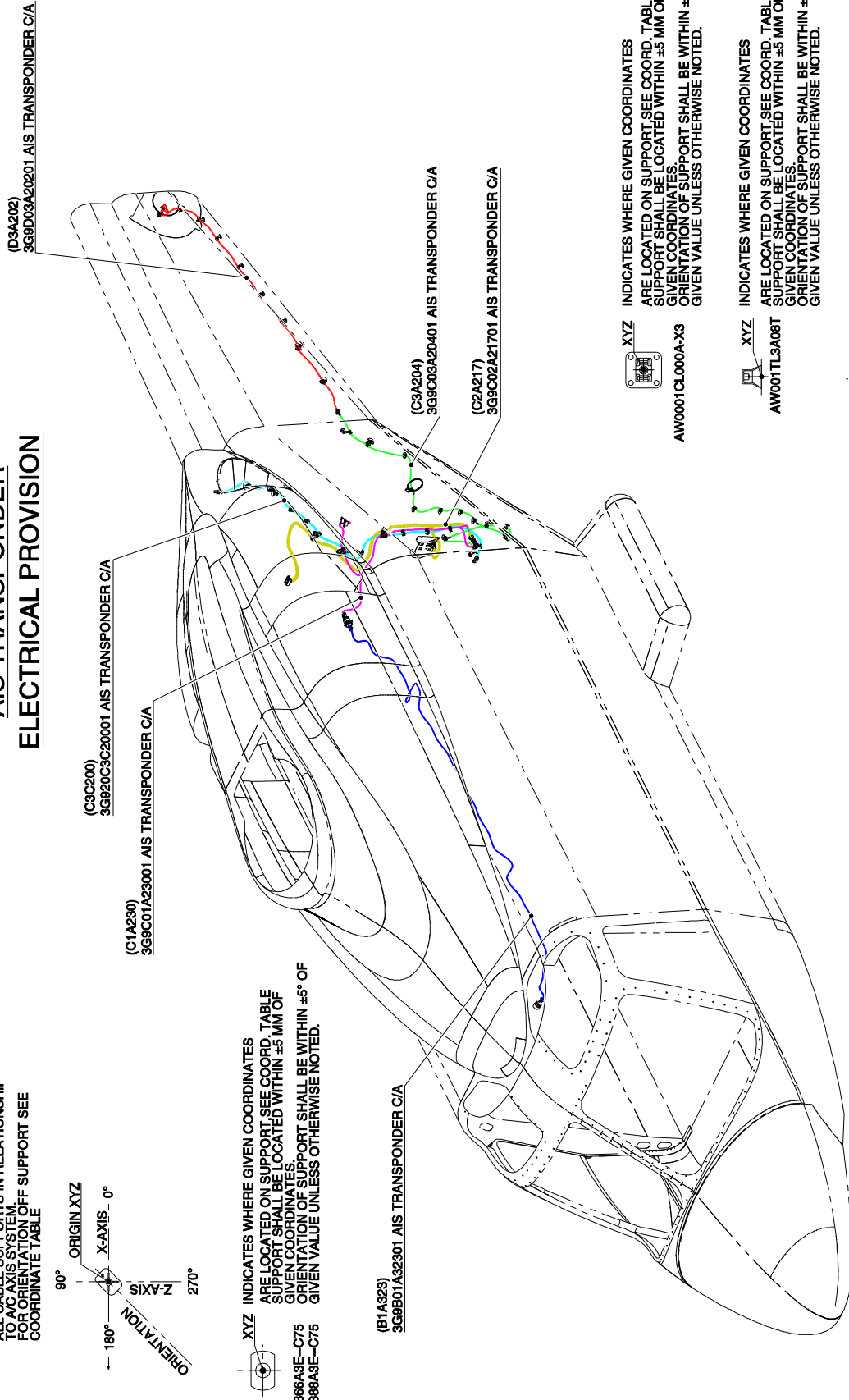

**XYZ** INDICATES WHERE GIVEN COORDINATES  
ARE LOCATED ON SUPPORT. SEE COORD. TABLE  
SUPPORT SHALL BE LOCATED WITHIN  $\pm 5$  MM OF  
GIVEN COORDINATES.  
ORIENTATION OF SUPPORT SHALL BE WITHIN  $\pm 5^\circ$  OF  
GIVEN VALUE UNLESS OTHERWISE NOTED.

AW001CL005--

**XYZ** INDICATES WHERE GIVEN COORDINATES  
ARE LOCATED ON SUPPORT. SEE COORD. TABLE  
SUPPORT SHALL BE LOCATED WITHIN  $\pm 5$  MM OF  
GIVEN COORDINATES.  
ORIENTATION OF SUPPORT SHALL BE WITHIN  $\pm 5^\circ$  OF  
GIVEN VALUE UNLESS OTHERWISE NOTED.

AW0001CL000A-X3

**XYZ** INDICATES WHERE GIVEN COORDINATES  
ARE LOCATED ON SUPPORT. SEE COORD. TABLE  
SUPPORT SHALL BE LOCATED WITHIN  $\pm 5$  MM OF  
GIVEN COORDINATES.  
ORIENTATION OF SUPPORT SHALL BE WITHIN  $\pm 5^\circ$  OF  
GIVEN VALUE UNLESS OTHERWISE NOTED.

AW001TL3A08T

**XYZ** INDICATES WHERE GIVEN COORDINATES  
ARE LOCATED ON SUPPORT. SEE COORD. TABLE  
SUPPORT SHALL BE LOCATED WITHIN  $\pm 5$  MM OF  
GIVEN COORDINATES.  
ORIENTATION OF SUPPORT SHALL BE WITHIN  $\pm 5^\circ$  OF  
GIVEN VALUE UNLESS OTHERWISE NOTED.

A386A3E-C  
A388A3E-C

Figure 12

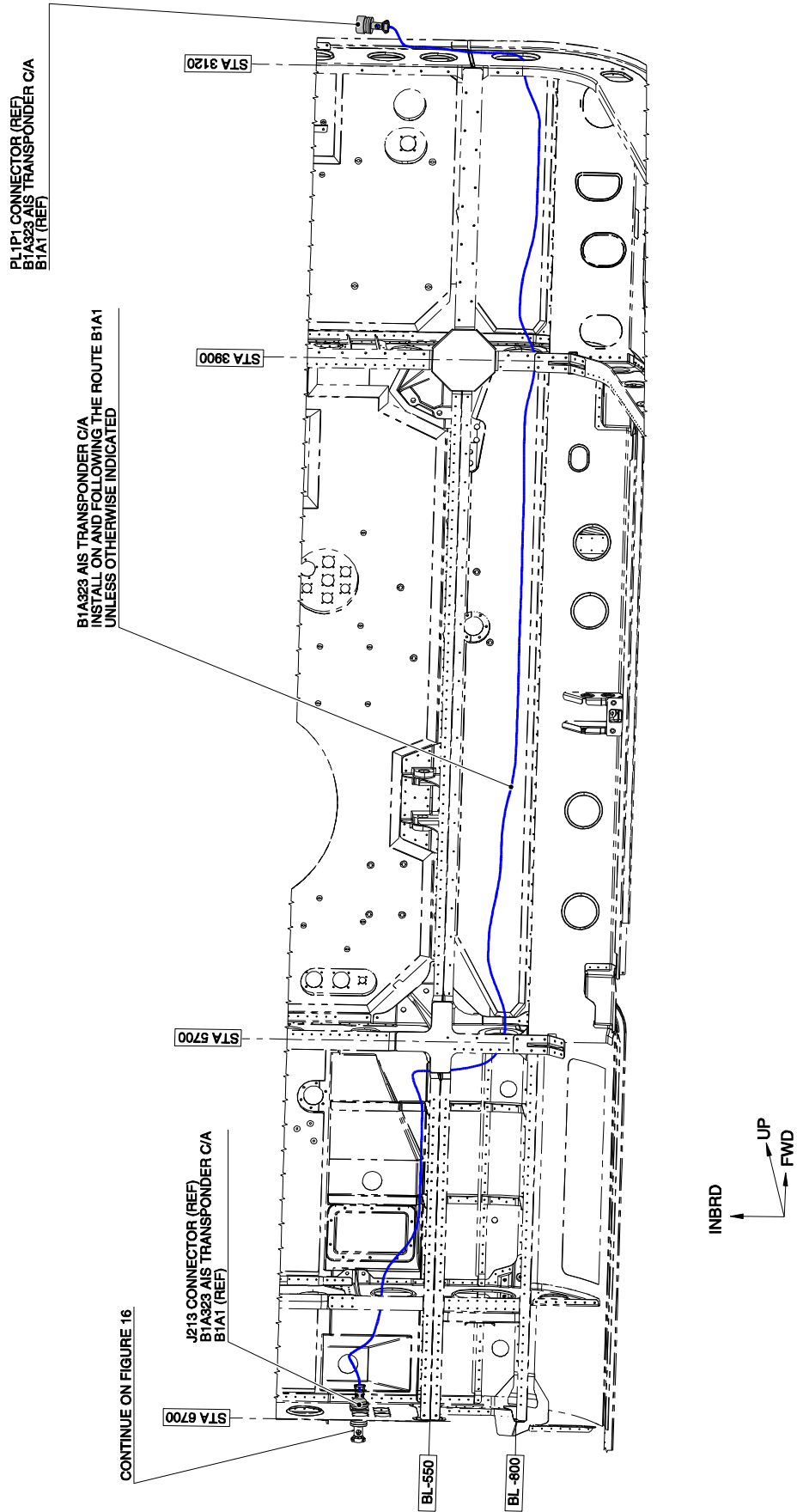

**VIEW LOOKING UP ROOF LH SIDE**  
STRUCTURES AND SYSTEMS ARE PARTIALLY  
OMITTED FOR BETTER CLARITY PURPOSE

**Figure 13**

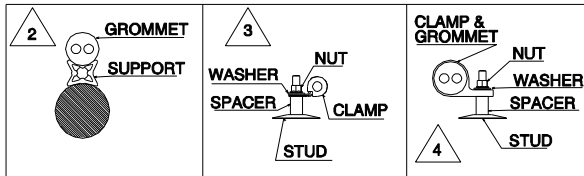

LOCATION NUMBER	PART. NUMBER	STA	BL	WL	ORIENTATION
①	A366A3E18C	7144	-796	1865	
②	A366A3E22C	7116	-969	1804	
③	A366A3E22C	7119	-958	1443	

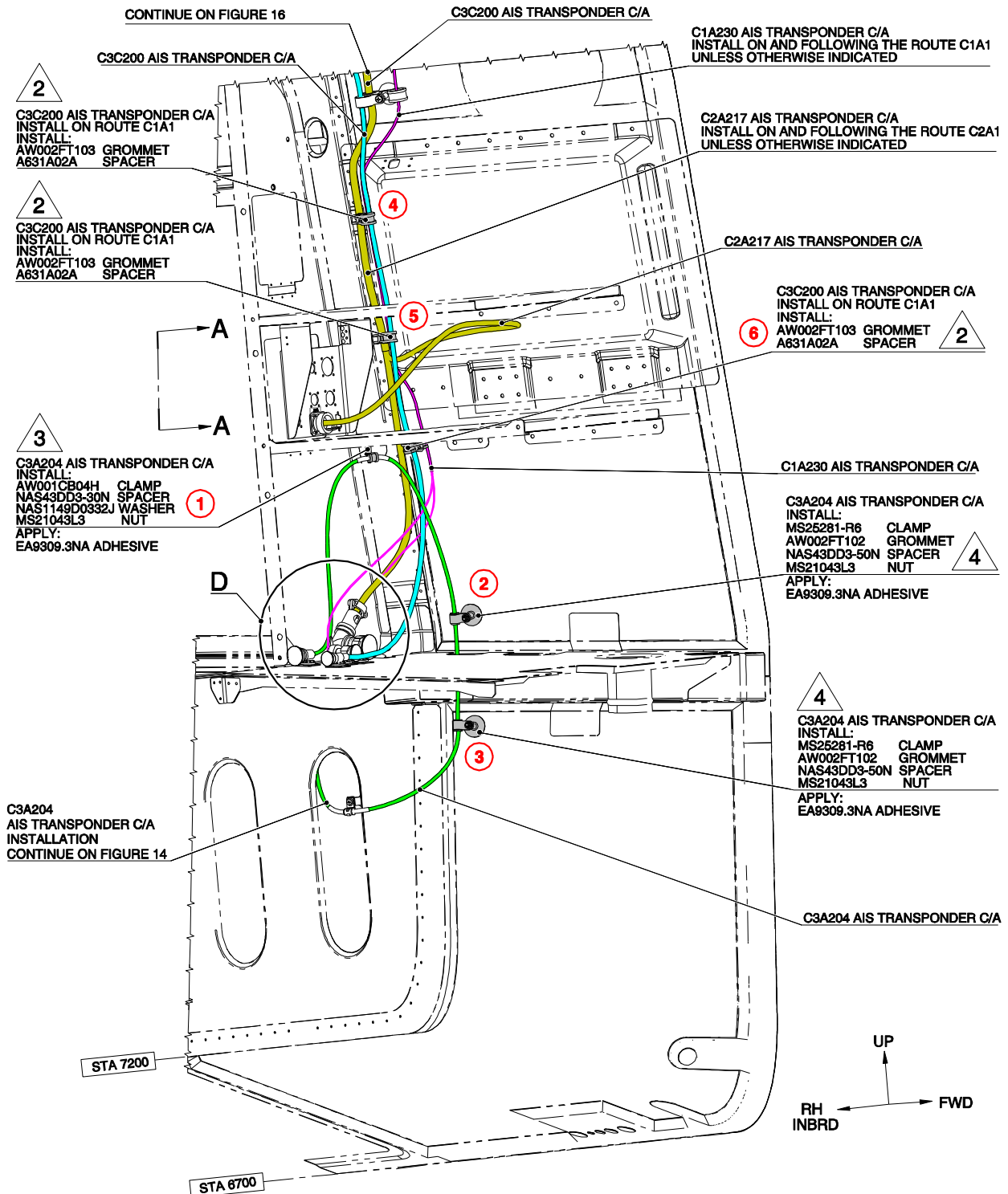

### VIEW LOOKING REAR LH SIDE AVIONIC BAY

STRUCTURES AND SYSTEMS ARE PARTIALLY OMITTED FOR BETTER CLARITY PURPOSE

Figure 14

S.B. N°139-703 OPTIONAL  
DATE: October 17, 2023  
REVISION: /



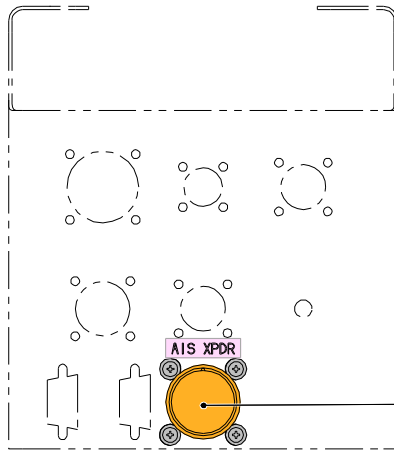

LOCATION NUMBER	PART. NUMBER	STA	BL	WL	ORIENTATION
7	AW001CL000A-X3	7139	-697	1551	90°
8	AW001CL000A-X3	7139	-730	1551	90°
9	AW001CL000A-X3	7116	-647	1549	0°
10	AW001CL000A-X3	7174	-647	1553	0°

**J375 CONNECTOR**  
**INSTALL:**  
 NAS1149DN416J WASHER (4 OFF)  
 NAS1802-04-7 SCREW (4 OFF)  
 M85049/95-16A-A FLANGE (FAR SIDE)  
 ED300AIS;XPDR DECAL  
 ED300J375 DECAL (FAR SIDE)  
 D38999/33J15R DUST CUP

**VIEW A-A**

STRUCTURES AND SYSTEMS ARE PARTIALLY OMITTED FOR BETTER CLARITY PURPOSE

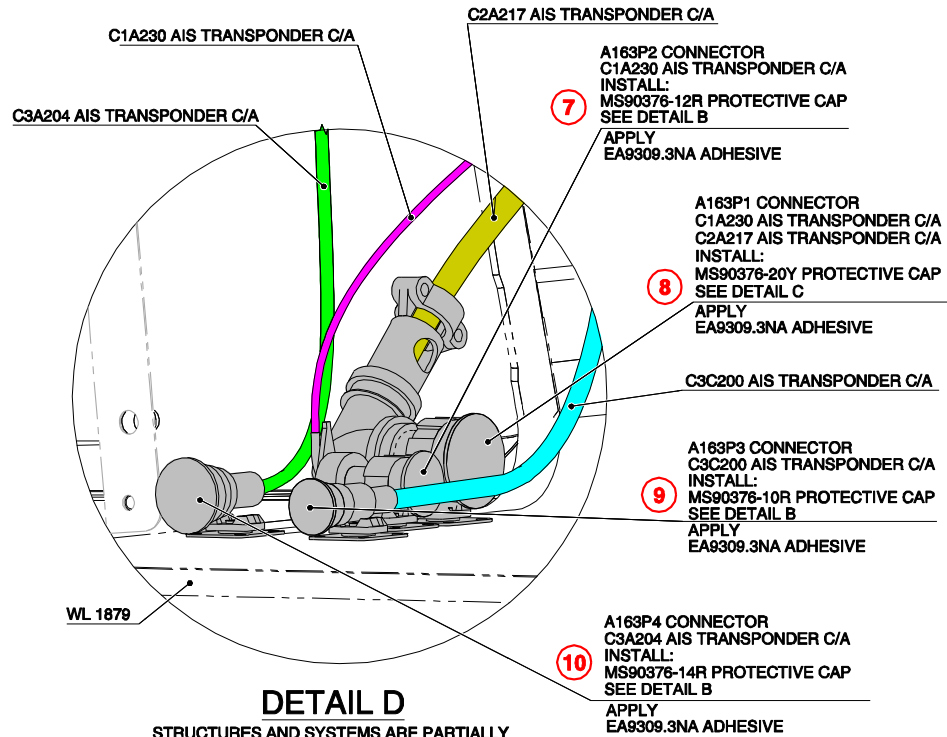

**DETAIL D**

STRUCTURES AND SYSTEMS ARE PARTIALLY OMITTED FOR BETTER CLARITY PURPOSE

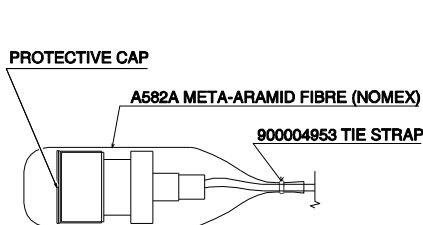

INSERT THE CONNECTOR ASSEMBLY INTO THE PROTECTIVE PLUG. COVER WITH THE NOMEX FIBRE SLEEVE AND USE THE CABLE STRAPS TO TIE UP SLEEVE FIRMLY TO THE CONNECTOR CABLING. USE CABLE STRAPS TO FIX THE CONNECTOR ASSY TO THE CABLE LOOM OR SUPPORT.

**DETAIL B**

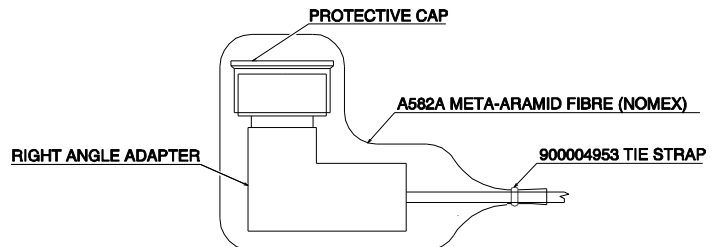

INSERT THE CONNECTOR ASSEMBLY INTO THE PROTECTIVE PLUG. COVER WITH THE NOMEX FIBRE SLEEVE AND USE THE CABLE STRAPS TO TIE UP SLEEVE FIRMLY TO THE CONNECTOR CABLING. USE CABLE STRAPS TO FIX THE CONNECTOR ASSY TO THE CABLE LOOM OR SUPPORT.

**DETAIL C**

**Figure 15**

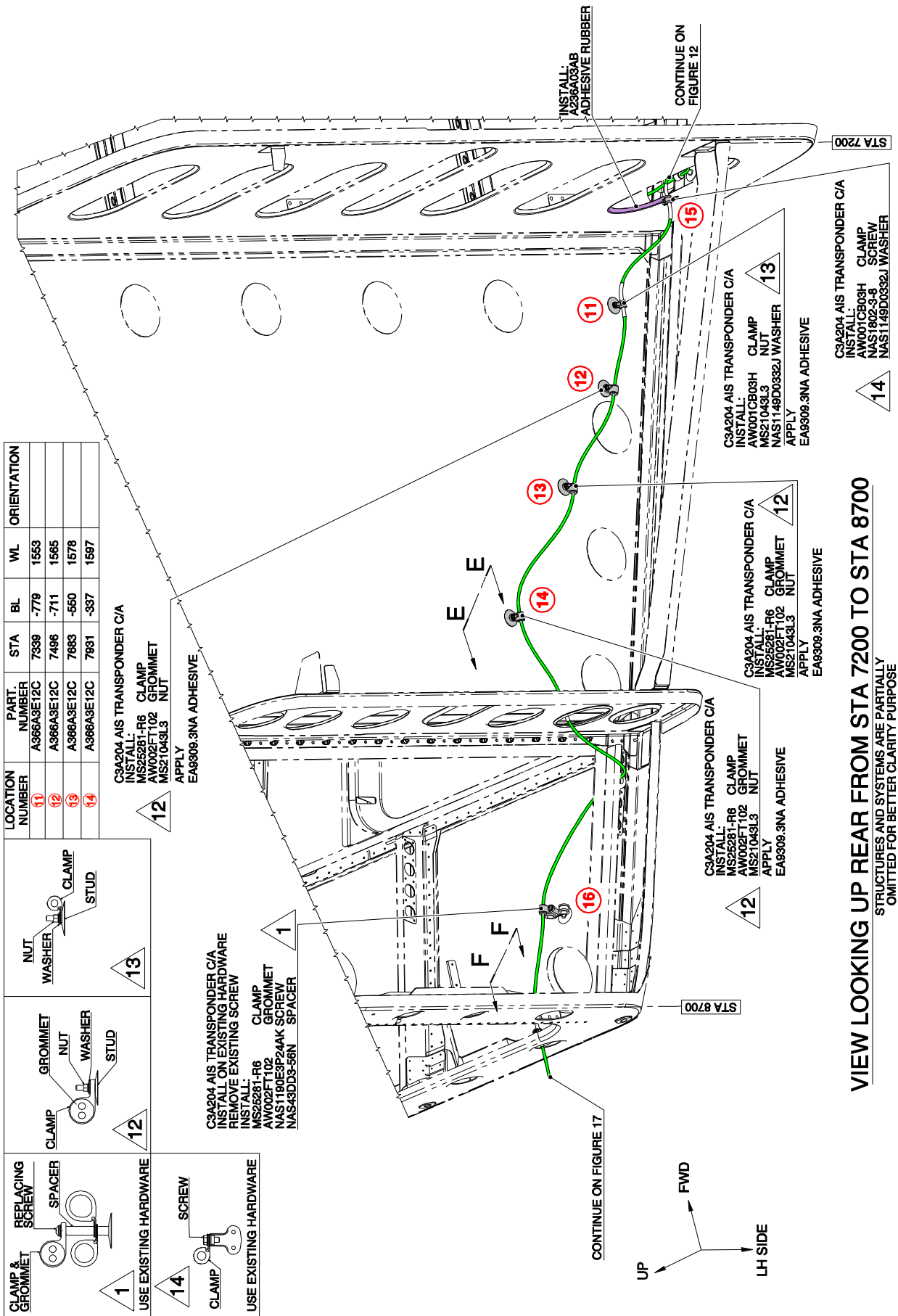
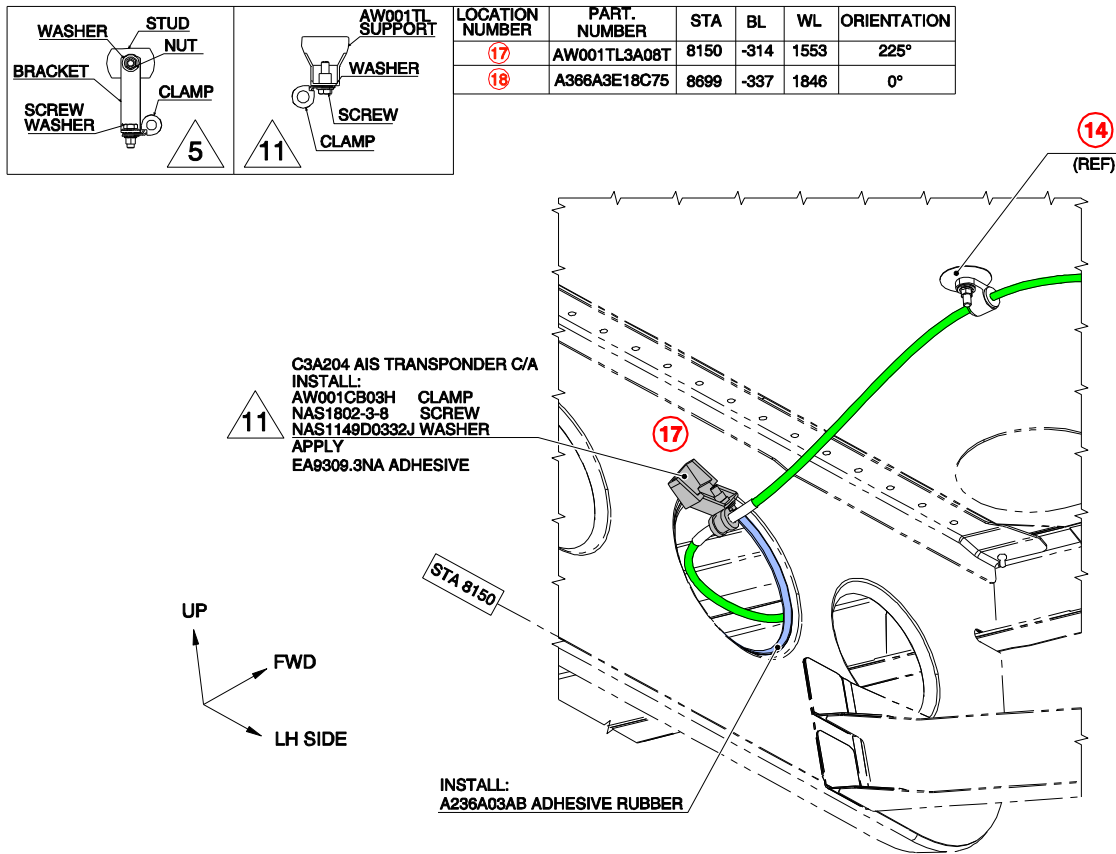
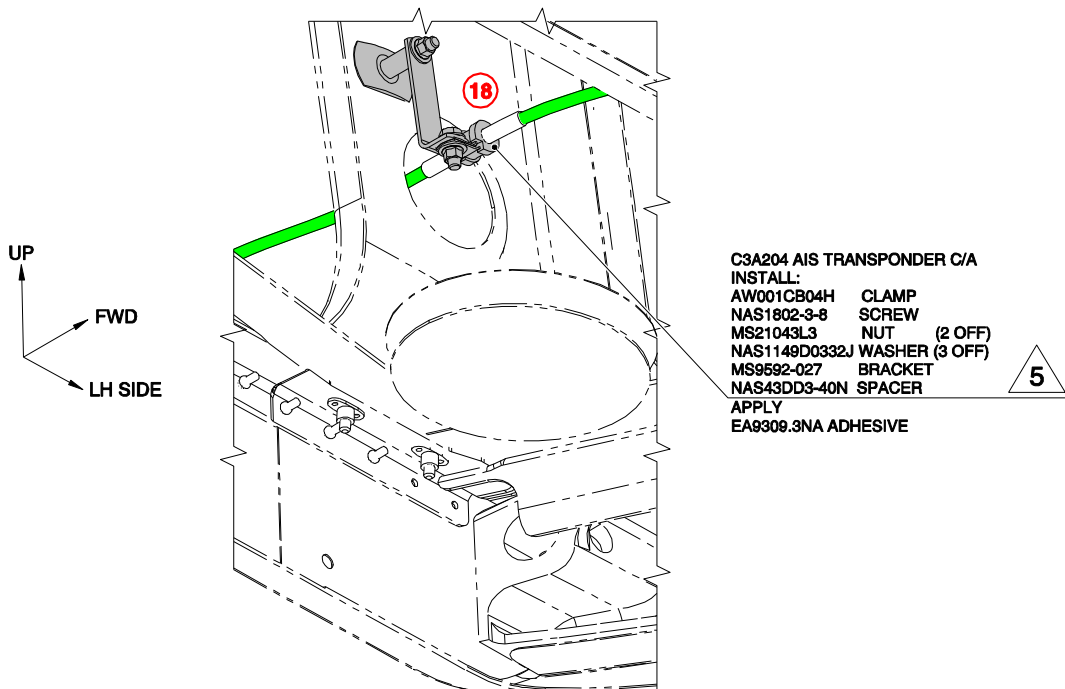

Figure 16



**VIEW E-E**  
STRUCTURES AND SYSTEMS ARE PARTIALLY OMITTED FOR BETTER CLARITY PURPOSE



**VIEW F-F**  
STRUCTURES AND SYSTEMS ARE PARTIALLY OMITTED FOR BETTER CLARITY PURPOSE

**Figure 17**



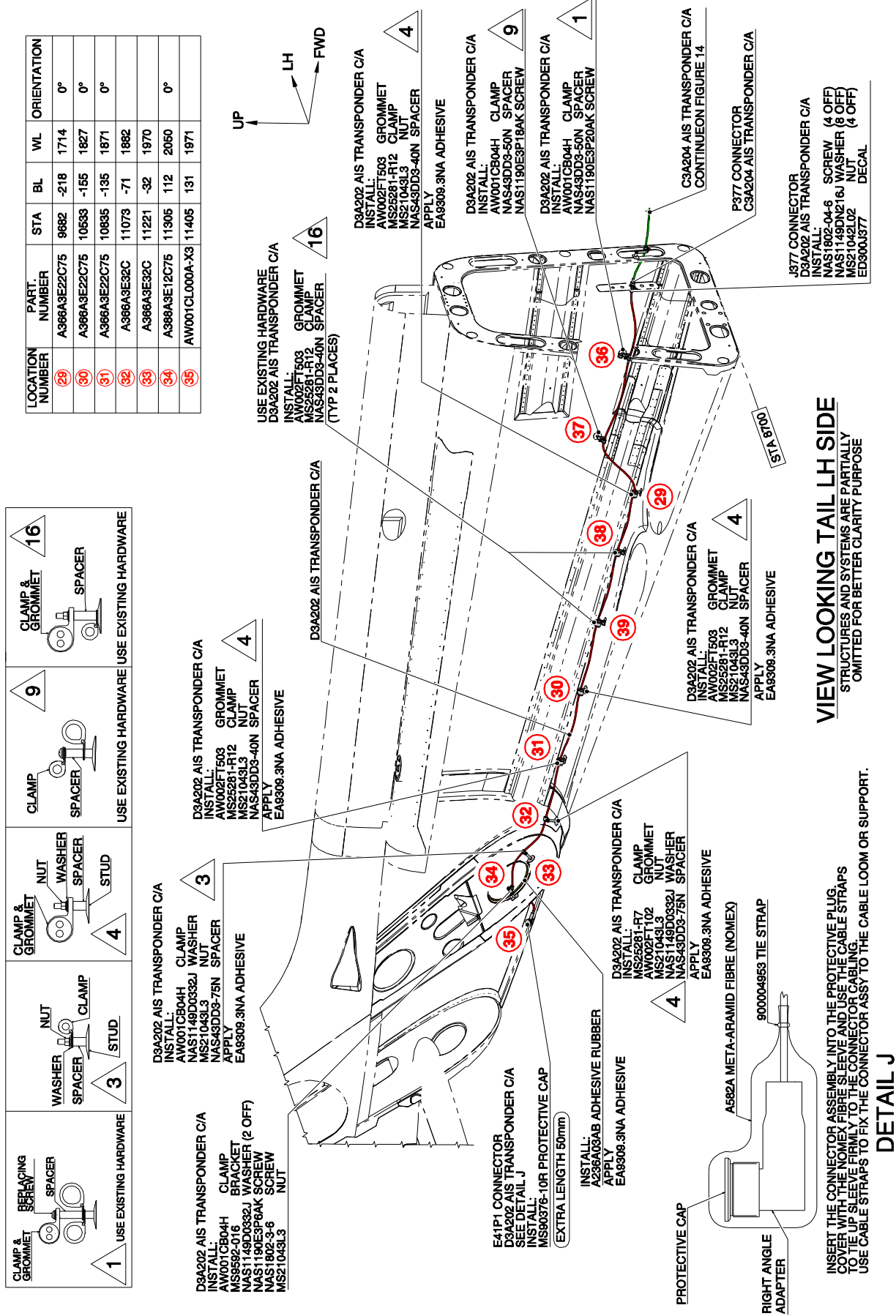
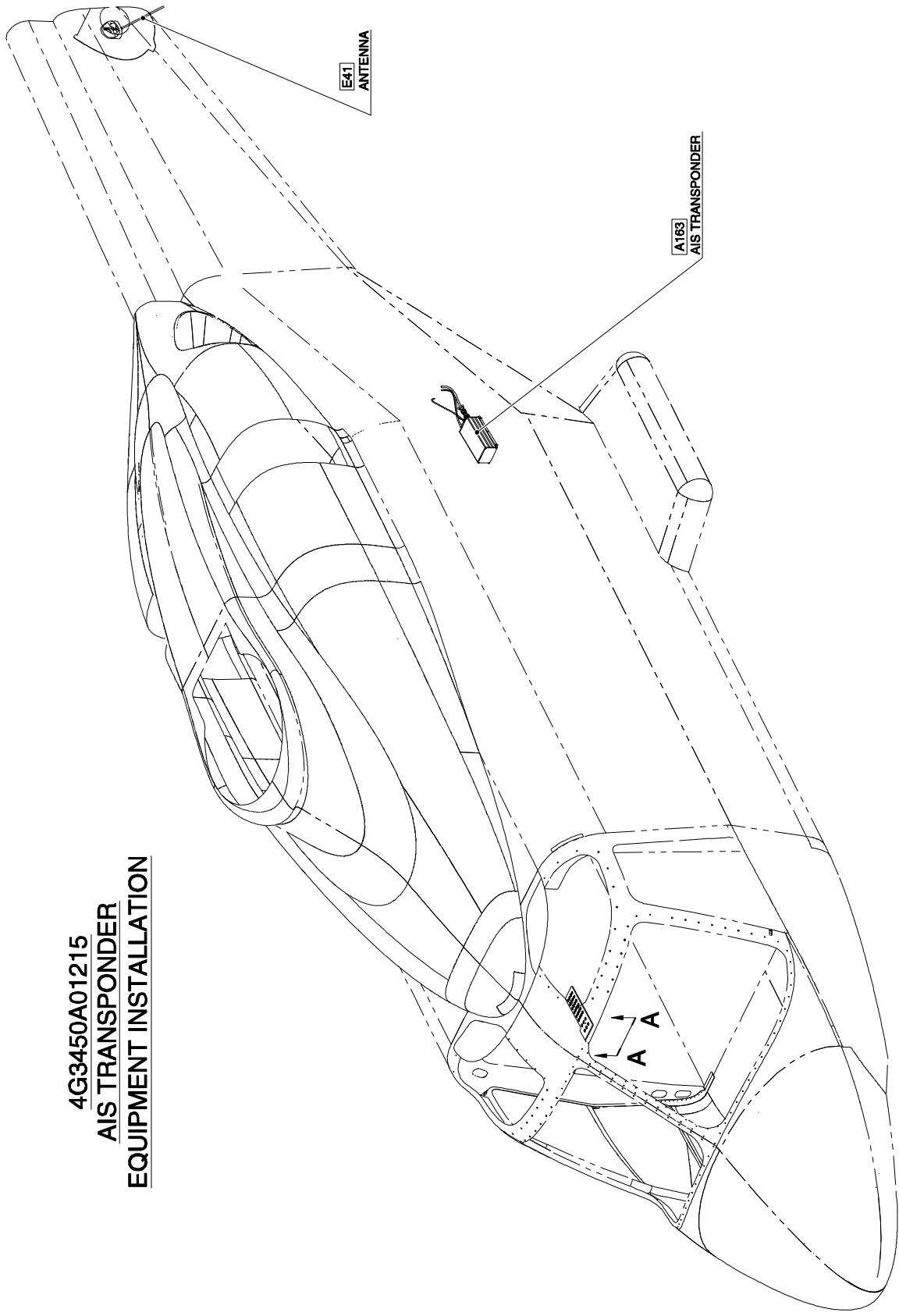

Figure 19



**4G3450A01215  
AIS TRANSPONDER  
EQUIPMENT INSTALLATION**

**Figure 20**

S.B. N°139-703 OPTIONAL  
DATE: October 17, 2023  
REVISION: /

**NOTE:**

1. P/N 7000-119-121 AND P/N 7000-119-109 ARE PART OF THE KIT AIS TRANSPONDER P/N 7001-000-131

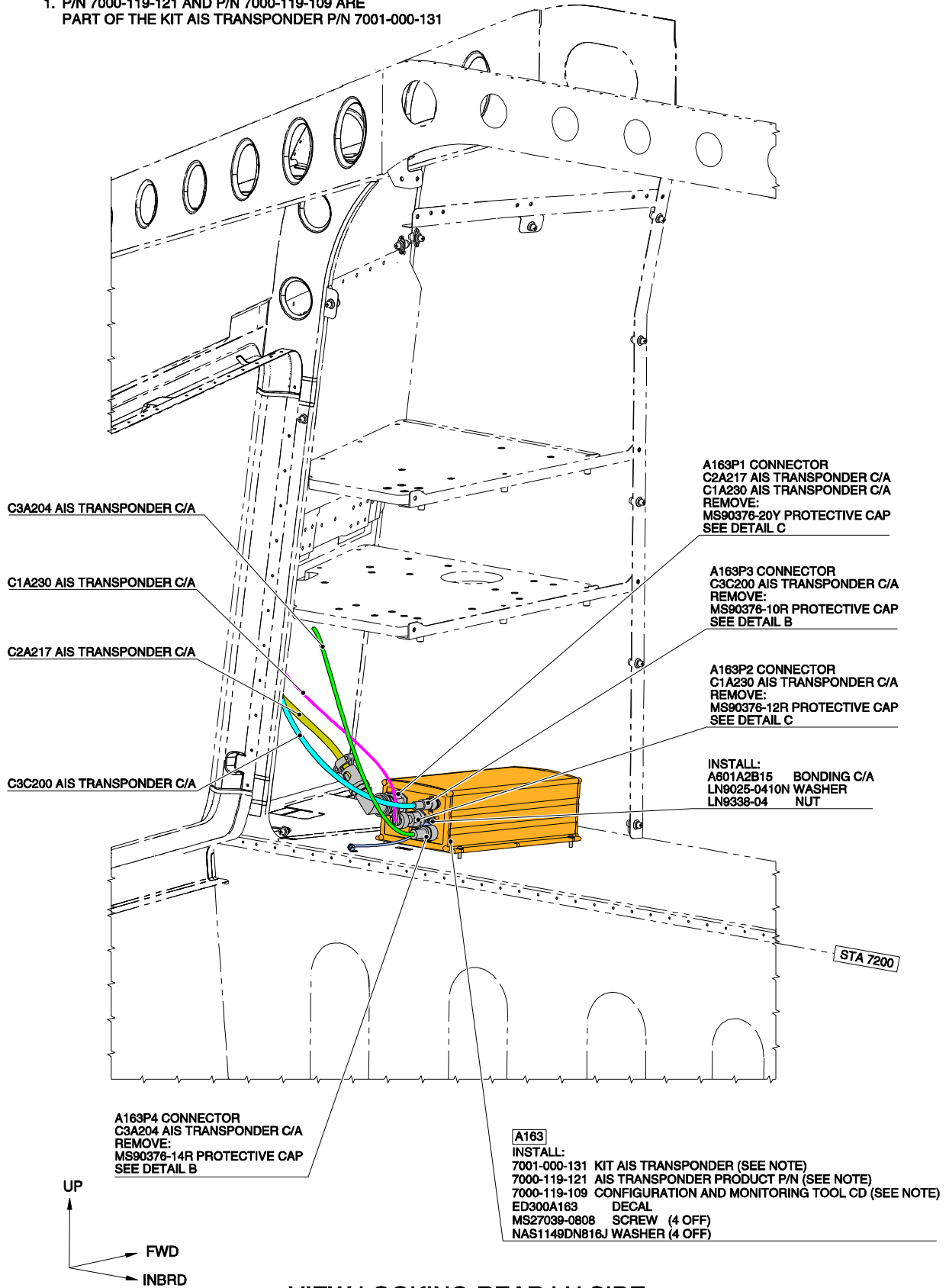

**VIEW LOOKING REAR LH SIDE**

STRUCTURES AND SYSTEMS ARE PARTIALLY OMITTED FOR BETTER CLARITY PURPOSE

**Figure 21**

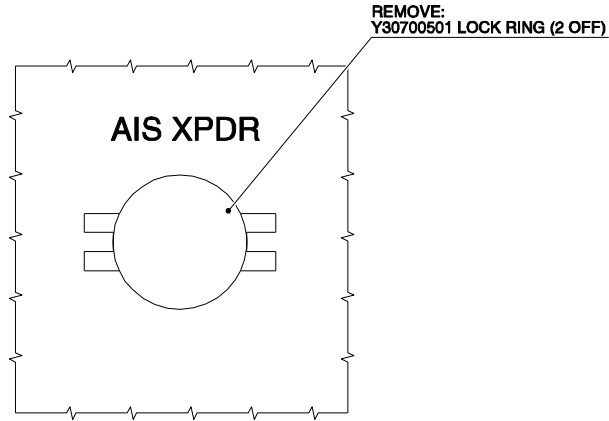

**VIEW A-A**

STRUCTURES AND SYSTEMS ARE PARTIALLY OMITTED FOR BETTER CLARITY PURPOSE

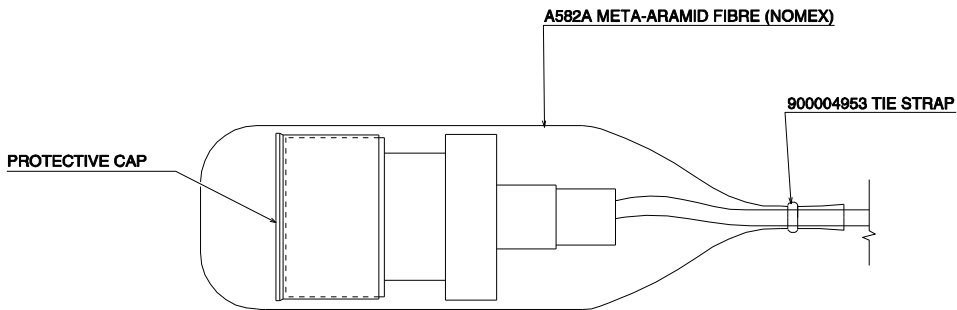

UNTIE CONNECTOR ASSY FROM THE LOOM.  
REMOVE THE NOMEX FIBRE SLEEVE AND THE PROTECTIVE PLUG  
FROM THE CONNECTOR AND FIX THE CONNECTOR  
TO THE EQUIPMENT.

**DETAIL C**

STRUCTURES AND SYSTEMS ARE PARTIALLY OMITTED FOR BETTER CLARITY PURPOSE

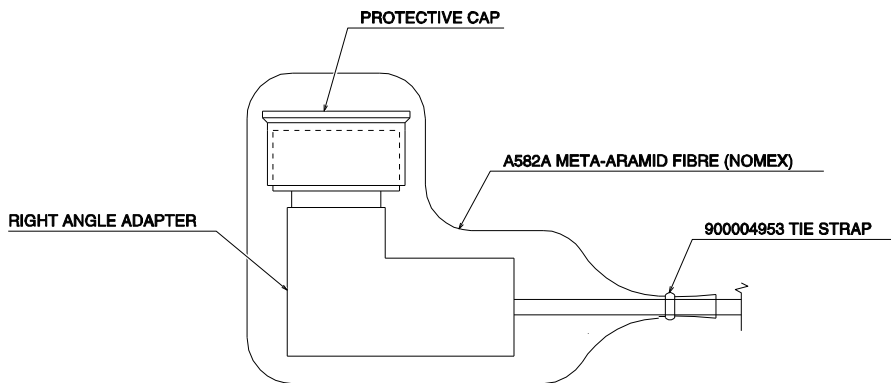

UNTIE CONNECTOR ASSY FROM THE LOOM.  
REMOVE THE NOMEX FIBRE SLEEVE AND THE PROTECTIVE PLUG  
FROM THE CONNECTOR AND FIX THE CONNECTOR  
TO THE EQUIPMENT.

**DETAIL B**

STRUCTURES AND SYSTEMS ARE PARTIALLY OMITTED FOR BETTER CLARITY PURPOSE

**Figure 22**



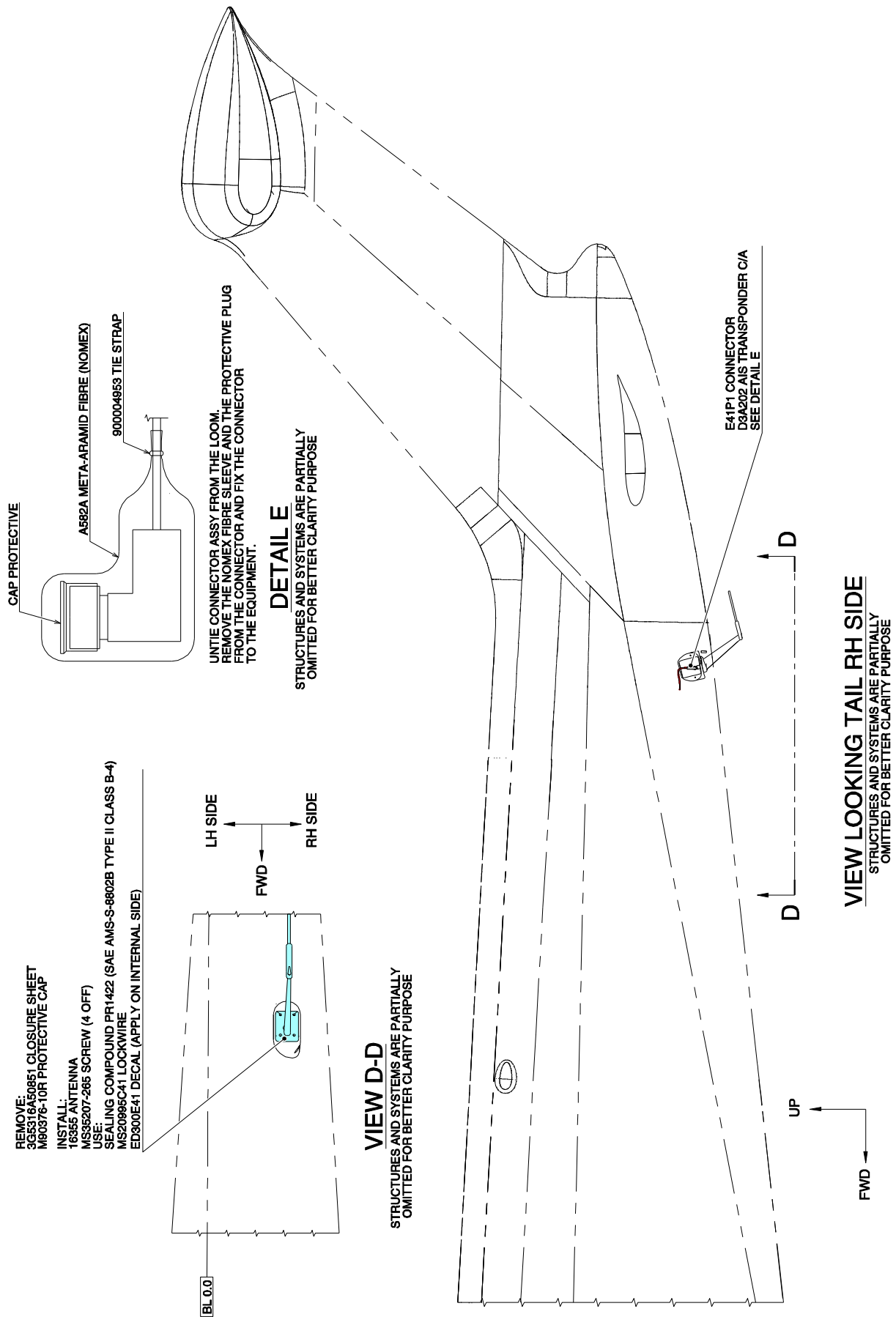

**Figure 23**

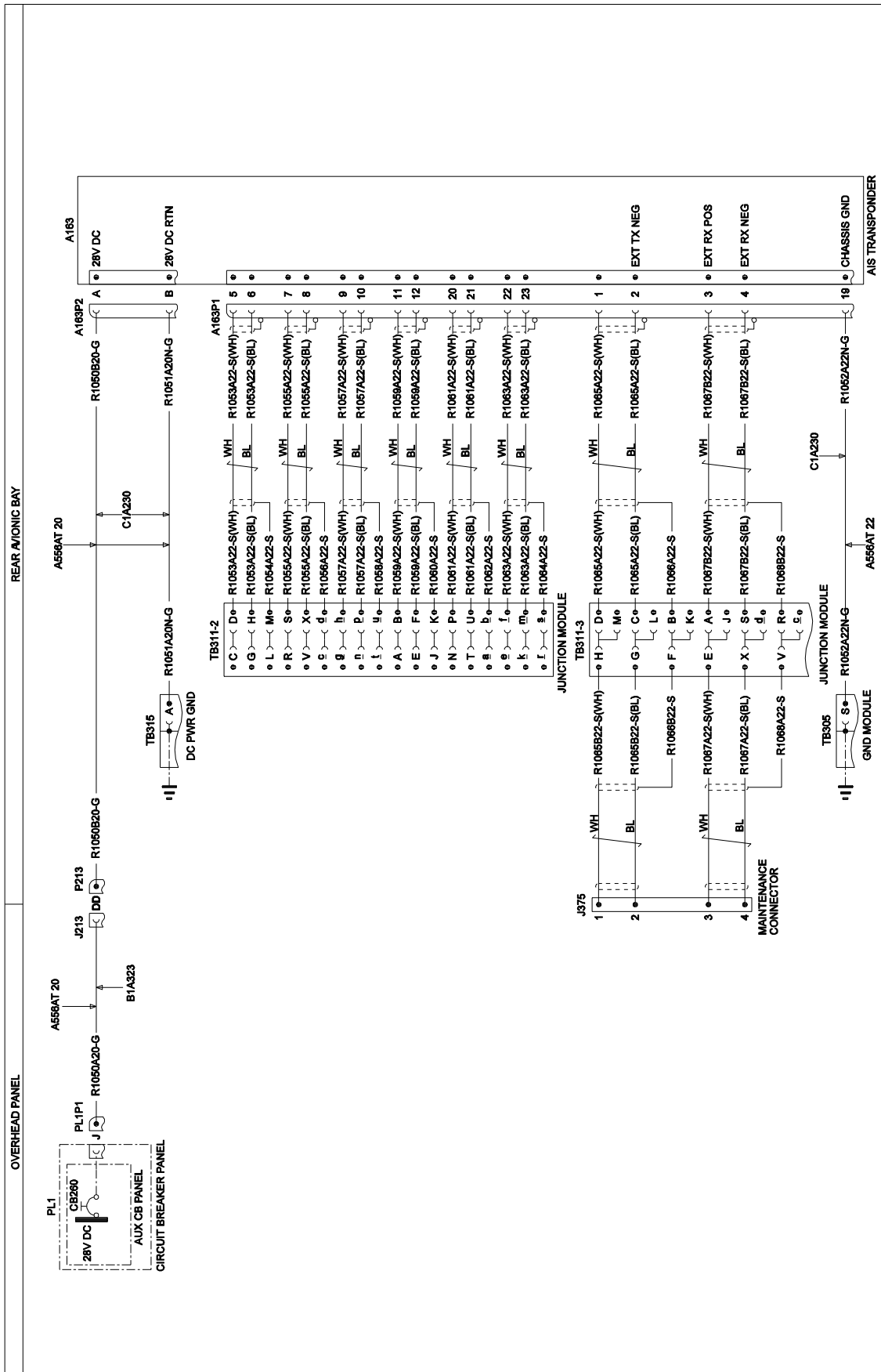

**3G3450W00911**  
**WIRING DIAGRAM AIS TRANSPONDER**  
SHEET 1

**FUNCTIONAL NOTES**  
ALL CABLES ARE IN LOOMC2A217 UNLESS SPECIFIED  
ALL CABLES ARE OF TYPEA561AT2 22 UNLESS SPECIFIED

Figure 24

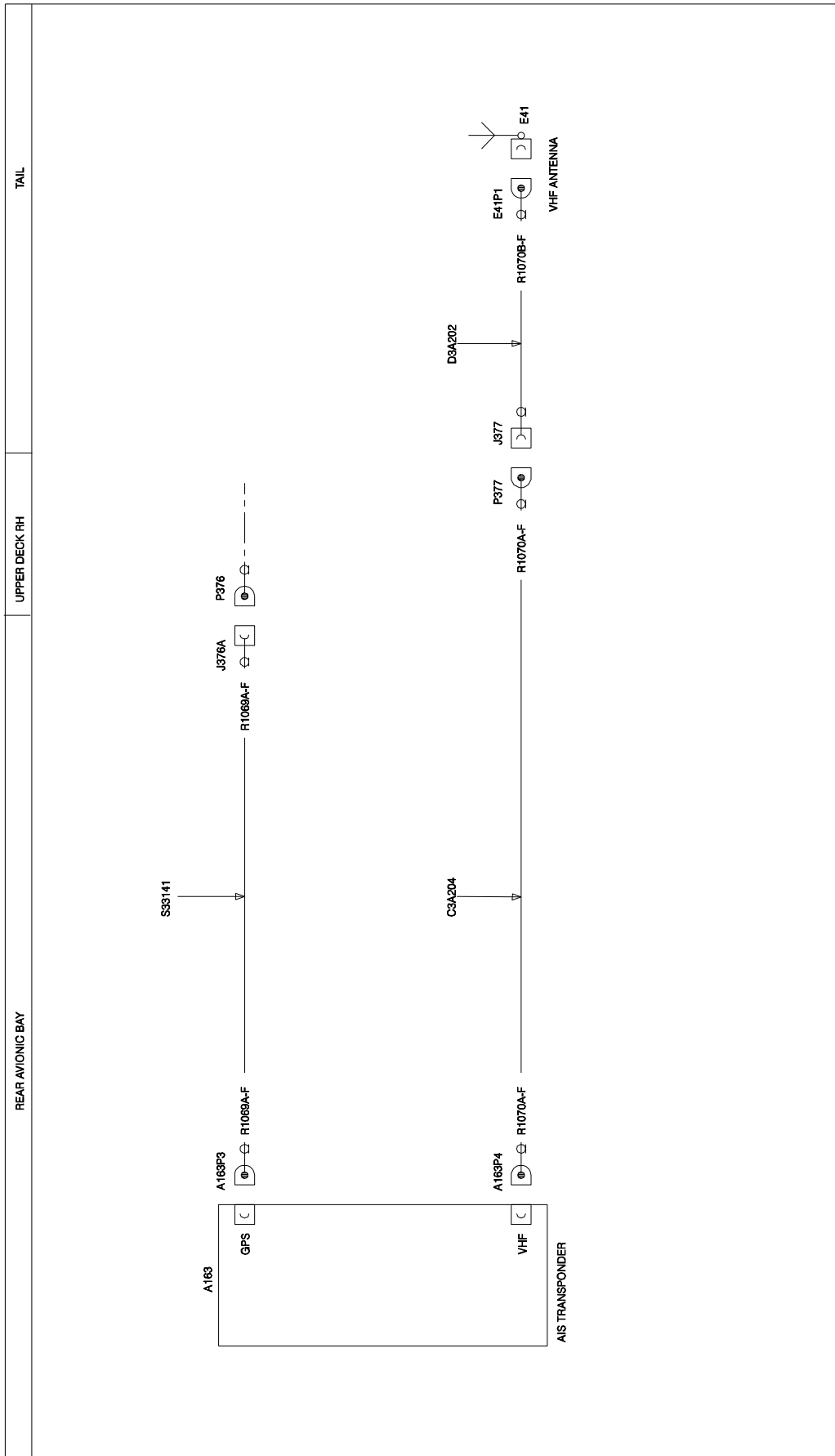

3G3450W00911  
**WIRING DIAGRAM AIS TRANSPONDER**  
SHEET 2

**FUNCTIONAL NOTES**  
ALL CABLES ARE IN LOOM C3C200 UNLESS SPECIFIED  
ALL CABLES ARE OF TYPE M17/175-00001 UNLESS SPECIFIED

**Figure 25**

Please send to the following address:  <b>LEONARDO S.p.A.</b> <b>CUSTOMER SUPPORT &amp; SERVICES - ITALY</b>  <b>PRODUCT SUPPORT ENGINEERING &amp; LICENSES DEPT.</b> Via Giovanni Agusta, 520 21017 Cascina Costa di Samarate (VA) - ITALY Tel.: +39 0331 225036 Fax: +39 0331 225988		<b>SERVICE BULLETIN COMPLIANCE FORM</b>		Date:	
		Number:			
		Revision:			
Customer Name and Address:			Telephone:		
			Fax:		
			B.T. Compliance Date:		
Helicopter Model	S/N	Total Number	Total Hours	T.S.O.	
Remarks:					
<p>Information:</p> <p>We request your cooperation in filling this form, in order to keep out statistical data relevant to aircraft configuration up-to-date. The form should be filled in all its parts and sent to the above address or you can communicate the application also via Technical Bulletin Application Communication Section placed in Leonardo AW Customer Portal - MyCommunications Area. We thank you beforehand for the information given.</p>					