SERVICE BULLETIN

N° **139-677**

OPTIONAL

DATE: July 30, 2024

REV. : /

TITLE

ATA 23 - 150 FT AURAL INHIBIT KIT P/N 4G2350F01511, INSTALLATION OF

REVISION LOG

First Issue

1. PLANNING INFORMATION

A. EFFECTIVITY

NOTE

The software loaded on A/C Primus Epic ® Phase 4 Software release 4.8 or higher is a mandatory prerequisite for the compliance with this Service Bulletin.

PART I: AW139 helicopters from S/N 31005 to S/N 31200 and from S/N 41001 to S/N 41200.

PART II: AW139 helicopters from S/N 31201 onwards and from S/N 41201 onwards.

B. COMPLIANCE

At Customer's option.

C. CONCURRENT REQUIREMENTS

N.A.

D. REASON

This Service Bulletin is issued in order to provide the necessary instruction on how to perform the installation of the kit 150 ft Aural Inhibit P/N 4G2350F01511.

LHD issued this SB for the following reason:

Helicopter Reliability/Maintainability	
Product Improvement	
Obsolescence	
Customization	✓
Product/Capability Enhancement	

E. DESCRIPTION

Through the installation of kit P/N 4G2350F01511 this Service Bulletin gives the operators of AW139 helicopters the option to add a new white STATUS Message “150 FT AURAL INHIB” in the CAS list of MFDs.

F. APPROVAL

The technical content of this Service Bulletin is approved under the authority of DOA nr. EASA.21.J.005. For helicopters registered under other Aviation Authorities, before applying the Service Bulletin, applicable Aviation Authority approval must be checked within Leonardo Helicopters customer portal.

EASA states mandatory compliance with inspections, modifications or technical directives and related time of compliance by means of relevant Airworthiness Directives.

If an aircraft listed in the effectivity embodies a modification or repair not LHD certified and affecting the content of this Service Bulletin, it is responsibility of the Owner/Operator to obtain a formal approval by Aviation Authority having jurisdiction on the aircraft, for any adaptation necessary before incorporation of the present Service Bulletin.

G. MANPOWER

To comply with this Service Bulletin the following MMH are deemed necessary.

Part I: approximately forty (40) MMH

Part II: approximately forty (40) MMH

MMH are based on hands-on time and can change with helicopter configuration, personnel and facilities available. MMH are not comprehensive of the overall hours necessary to get access to work areas and to remove all the equipment that interferes with the application of the prescribed instructions.

H. WEIGHT AND BALANCE

PART I

WEIGHT (Kg)	ARM (mm)	MOMENT (Kgmm)
		0.325
LONGITUDINAL BALANCE	3082	1001.7
LATERAL BALANCE	627	203.8

PART II

WEIGHT (Kg)	ARM (mm)	MOMENT (Kgmm)
		0.355
LONGITUDINAL BALANCE	3086	1095.5
LATERAL BALANCE	629	223.3

I. REFERENCES

I.1 PUBLICATIONS

Following Data Modules refer to AMP:

<u>DATA MODULE</u>	<u>DESCRIPTION</u>	<u>PART</u>
DM01 39-A-00-20-00-00A-120A-A	Helicopter on ground for a safe maintenance.	I, II
DM02 39-A-06-41-00-00A-010A-A	Access doors and panels - General data	I, II
DM03 39-A-25-82-04-00A-520A-A	Right hinged lining panel - Remove procedure	I, II
DM04 39-A-25-21-01-00A-520A-K	Cabin seat - Remove procedure	I, II
DM05 39-A-25-22-01-00A-520A-K	Cabin seat - Remove procedure	I, II
DM06 39-A-11-00-01-00A-720A-A	Decal - Install procedure	I, II
DM07 39-A-25-21-01-00A-720A-K	Cabin seat - Install procedure	I, II
DM08 39-A-25-22-01-00A-720A-K	Cabin seat - Install procedure	I, II
DM09 39-A-25-82-04-00A-720A-A	Right hinged lining panel - Install procedure	I, II

I.2 ACRONYMS

AMDI	Aircraft Material Data Information
AMP	Aircraft Maintenance Publication
CAS	Crew Alerting System
CDS	Cockpit Display System
DM	Data Module
DOA	Design Organization Approval
EASA	European Union Aviation Safety Agency
FT	Feet
LHD	Leonardo Helicopters Division
IPD	Illustrated Parts Data
ITEP	Illustrated Tool and Equipment Publication
MMH	Maintenance Man Hours
MFD	Multifunction Display
N.A.	Not Applicable
P/N	Part Number
PDF	Primary Flight Display
RH	Right Hand
S/N	Serial Number

I.3 ANNEX

Annex A 150 FT Aural inhibit installation Functional test.

J. PUBLICATIONS AFFECTED

N.A.

K. SOFTWARE ACCOMPLISHMENT SUMMARY

N.A.

2. MATERIAL INFORMATION

A. REQUIRED MATERIALS

A.1 PARTS

PART I

#	P/N	ALTERNATIVE P/N	DESCRIPTION	Q.TY	LVL	NOTE	LOG P/N
1	4G2350F01511		150 FT AURAL INHIB KIT	REF	.		-
2	4G2350A04211		150 FT AURAL INHIB COMPLETE PROVISION	REF	..		-
3	3G5310A42011		150 ft aural inhibit structural provision	REF	...		-
4	MS21069L08		Nut plate	2		139-677L1
5	MS20426AD3-4		Rivet	0.1 kg		139-677L1
6	4G2350A04311		150 ft aural inhibit electrical installation	REF	...		-
7	3G9B01A07401		150 ft aural inhibit cable assy (B1A74)	1		139-677L1
8	3G9B01B08501	4G2350A04311A1R	150 ft aural inhibit cable assy (B1B85)	1		139-677L1
9	3G9B01B08601		150 ft aural inhibit cable assy (B1B86)	1		139-677L1
10	A236A02AB		Nonmetallic channel	1.2 m		139-677L1
11	ED300K163		Decal	1		139-677L1
12	MS24694-S3		Screw	2		139-677L1
13	M12883/53-001		Rail	1		139-677L1
14	M83536/2-028M		Relay	1		139-677L1
15	M39029/56-348		Electrical contact	2		139-677L1
16	M39029/56-351		Electrical contact	3		139-677L1
17	M39029/57-354		Electrical contact	2		139-677L1
18	M39029/58-363		Electrical contact	3		139-677L1
19	A523A-A02		Electrical contact	4		139-677L1
20	A590A02		Ferule	2		139-677L1

PART II

#	P/N	ALTERNATIVE P/N	DESCRIPTION	Q.TY	LVL	NOTE	LOG P/N
22	4G2350F01511		150 FT AURAL INHIB KIT	REF	.		-
23	4G2350A04212 or 4G2350A04213		150 FT AURAL INHIB COMPLETE PROVISION	REF	..	(1)	-
24	3G5310A42012		150 ft aural inhibit structural provision	REF	...		-
25	MS21069L08		Nut plate	2		139-677L2
26	MS20426AD3-4		Rivet	0.1 kg		139-677L2
27	4G2350A04312 or 4G2350A04313		150 ft aural inhibit electrical installation	REF	...	(2)	-
28	3G9A01A31601		150 ft aural inhibit cable assy (A1A316)	1		139-677L2
29	3G9A01B32501		150 ft aural inhibit cable assy (A1B325)	1		139-677L2
30	3G9B01B47301		150 ft aural inhibit cable assy (B1B473)	1		139-677L2
31	A236A02AB		Nonmetallic channel	1.2 m		139-677L2
32	ED300K163		Decal	1		139-677L2

#	P/N	ALTERNATIVE P/N	DESCRIPTION	Q.TY	LVL	NOTE	LOG P/N
33	MS24694-S3		Screw	2		139-677L2
34	M12883/53-001		Rail	1		139-677L2
35	M83536/2-028M		Relay	1		139-677L2
36	M39029/56-348		Electrical contact	4		139-677L2
37	M39029/56-351		Electrical contact	1		139-677L2
38	M39029/56-352		Electrical contact	1		139-677L2
39	M39029/57-354		Electrical contact	3		139-677L2
40	M39029/58-360		Electrical contact	3		139-677L2
41	M39029/58-363		Electrical contact	2		139-677L2
42	A523A-A02		Electrical contact	4		139-677L2

Refer also to IPD for the spares materials required to comply with the AMP DMs referenced in the accomplishment instructions.

A.2 CONSUMABLES

The following consumable materials, or equivalent, are necessary to accomplish this Service Bulletin:

#	P/N	DESCRIPTION	Q.TY	NOTE	PART
44	EN6049-006-05-5 or A582A05	Nomex sleeve	AR	(3)	I, II

Refer also to AMDI for the consumable materials required to comply with the AMP DM referenced in the accomplishment instructions.

A.3 LOGISTIC MATRIX

In order to apply this Service Bulletin, the following Logistic P/N can be ordered in accordance with the applicable notes:

LOGISTIC P/N	Q.TY (PER HELO)	NOTE	PART
139-677L1	1		I
139-677L2	1		II

NOTE

- (1) P/N 4G2350A04212 is applicable to helicopters from S/N 31201 to S/N 31399 and from S/N 41201 to S/N 41299, while P/N 4G2350A04213 is applicable from S/N 31400 onwards and from S/N 41300 onwards.
- (2) P/N 4G2350A04312 is applicable to helicopters from S/N 31201 to S/N 31399 and from S/N 41201 to S/N 41299, while P/N 4G2350A04313 is applicable from S/N 31400 onwards and from S/N 41300 onwards.
- (3) Item to be procured as local supply.

B. SPECIAL TOOLS

Refer to ITEP for the special tools required to comply with the AMP DM referenced in the accomplishment instructions.

C. INDUSTRY SUPPORT INFORMATION

Customization.

3. ACCOMPLISHMENT INSTRUCTIONS

GENERAL NOTES

- a) Place an identification tag on all components that are re-usable, including the attaching hardware that has been removed to gain access to the modification area and adequately protect them until their later re-use.
- b) Shape the cables in order to prevent interference with the structure and the other existing installations, using where necessary suitable lacing cords.
- c) Use Nonmetallic channel P/N A236A02AB on edges which may cause damage to cable assemblies and where abrasion may occur.
- d) Use Nomex P/N A582A05 where protection against chafing is required and where contact with structure may occur.
- e) Exercise extreme care during drilling operations to prevent instruments, cables and hoses damage.
- f) After drilling, remove all swarf and sharp edges. Apply on bare metal a light film of primer unless the hole is used for ground connection.
- g) During the installation of bonding braids or components requiring grounding, clean the surface structure in order to obtain a good ground contact.
- h) All lengths are in mm.
- i) Prior to comply with this Service Bulletin make sure that the A/C is equipped with Primus Epic ® Phase 4 Software release 4.8 or higher.

PART I

1. In accordance with AMP DM 39-A-00-20-00-00A-120A-A, prepare the helicopter on ground for a safe maintenance. Disconnect the battery, all electrical power sources and/or the external power supply.
2. In accordance with AMP DM 39-A-06-41-00-00A-010A-A and with reference to Figure 1 thru Figure 7, gain access to the area affected by the installation and perform complete

provision 150 Ft aural inhibit kit P/N 4G2350F01511 as described in the following procedure:

3. With reference to AMP DM 39-A-25-82-04-00A-520A-A remove RH hinged lining panels.
4. With reference to AMP DM 39-A-25-21-01-00A-520A-K or 39-A-25-22-01-00A-520A-K remove cabin passenger seats.
5. With reference to AMP DM 39-A-06-41-00-00A-010A-A remove cabin floor panels 142AR, 152AR, 140BL, 150AL and RH roof cabin panel 152CR.
6. Remove interseat console lateral panels.

NOTE

Before complying with the following steps make a visual survey of the electrical installations which are present on the A/C since, depending upon A/C configuration, some electrical provisions could be already in the A/C.

7. With reference to Figure 1 install the 150 ft Aural Inhibit structural provision P/N 3G5310A42011, as follows:
 - 7.1 With reference to Figure 1 View A-A, mark position of two nut plates to be installed on upper deck.
 - 7.2 With reference to Figure a View A-A drill n°2 holes Ø 4.27 to 4.39 mm diameter at marked positions and install n°2 nut plates P/N MS21069L08 using n°4 rivets P/N MS20426AD4-3.
8. With reference to Figure 2 thru Figure 7, carry out the 150 ft Aural Inhibit electrical installation P/N 4G2350A04311, performing the following procedure:
 - 8.1 With reference to Figure 5 and Figure 15 Wiring Diagram disconnect wire F100A20-G, of route B1B161, laid down between PL1P6 connector of the Circuit Breaker panel and J52 sectioning connector in cabin roof. Remove wire F100A20-G or stow it in adjacent area.
 - 8.2 With reference to Figure 3, Figure 7 and Figure 15 Wiring Diagram disconnect wire R199A22N of route B1B2, laid down between PL27P2 connector of the Miscellaneous Control panel in the interseat console and P108 sectioning connector in cabin floor. Remove wire R199A22N or stow it in adjacent area.
 - 8.3 With reference to Figure 6 Detail B, install one rail P/N M12883/53-001 with n°2 screws P/N MS24694-S3, on the RH upper deck beam.
 - 8.4 With reference to Figure 6 Detail B, install one relay P/N M83536/2-028M (K163P1) into rail.
 - 8.5 In accordance with AMP DM 39-A-11-00-01-00A-720A-A, install decal

- P/N ED300K163 adjacent to the relay.
- 8.6 With reference to Figures 2 through Figure 7, lay down the below-listed cable assemblies, following existing routes:
 - 8.6.1 Cable assy 150 ft Aural Inhibit P/N 3G9B01A07401 C/A (B1A74)
 - 8.6.2 Cable assy 150 ft Aural Inhibit P/N 3G9B01B08501 C/A (B1B85)
 - 8.6.3 Cable assy 150 ft Aural Inhibit P/N 3G9B01B08601 C/A (B1B86)
 - 8.7 With reference to Figure 3, Figure 15 wiring diagram and table on Figure 17 make the electrical connections at A32P1 and A33P1 connectors of the Pilot's MFD and Copilot's MFD, at J16 connector behind the Instrument panel and at PL27P2 connector of the Miscellaneous Control panel.
 - 8.8 With reference to Figure 6 Detail B, Figure 15 wiring diagram and table on Figure 17 make the electrical connections at K163P1 connector of Relay K163. Make sure to protect with Nomex sleeve P/N A582A05 the wire crossing over the existing angle, as shown in Detail B.
 - 8.9 With reference to Figure 6 Detail C, Figure 15 wiring diagram and table on Figure 17 make the electrical connections at J62 and P62 sectioning connectors and at J52 P52 connectors on RH upper deck beam.
 - 8.10 With reference to Figure 7, Figure 15 wiring diagram and table on Figure 17 make the electrical connections at P108 sectioning connector on rear fuselage bottom floor.
 - 8.11 With reference to Figure 4, Figure 15 wiring diagram and table on Figure 17 make the electrical connections at PL1P6 connector of the Circuit Breaker panel.
 - 8.12 Perform a pin-to-pin continuity check to the connection performed.
9. Install interseat console lateral panels.
 10. With reference to AMP DM 39-A-06-41-00-00A-010A-A install cabin floor panels 142AR, 152AR, 140BL, 150AL and RH roof cabin panel 152CR.
 11. With reference to AMP DM 39-A-25-21-01-00A-720A-K or 39-A-25-22-01-00A-720A-K install cabin passenger seats.
 12. Perform a functional test of the MFDs in accordance with Annex A.
 13. With reference to AMP DM 39-A-25-82-04-00A-720A-A install RH hinged lining panels
 14. In accordance with weight and balance changes, update the Chart A (see Rotorcraft Flight Manual, Part II, section 6).
 15. Return the helicopter to flight configuration and record for compliance with Part I of this Service Bulletin on the helicopter logbook.
 16. Gain access to My Communications section on Leonardo WebPortal and compile the "Service Bulletin Application Communication".

As an alternative, send the attached compliance form to the following mail box:

engineering.support.lhd@leonardo.com

and (for North, Central and South America) also to:

AWPC.Engineering.Support@leonardocompany.us

PART II

1. In accordance with AMP DM 39-A-00-20-00-00A-120A-A, prepare the helicopter on ground for a safe maintenance. Disconnect the battery, all electrical power sources and/or the external power supply.
2. In accordance with AMP DM 39-A-06-41-00-00A-010A-A and with reference to Figure 8 thru Figure 14, gain access to the area affected by the installation and perform complete provision 150 Ft aural inhibit kit P/N 4G2350F01511 as described in the following procedure:
3. With reference to AMP DM 39-A-25-82-04-00A-520A-A remove RH hinged lining panels.
4. With reference to AMP DM 39-A-25-21-01-00A-520A-K or 39-A-25-22-01-00A-520A-K remove cabin passenger seats.
5. With reference to AMP DM 39-A-06-41-00-00A-010A-A remove cabin floor panels 142AR, 152AR, 140BL, 150AL and RH roof cabin panel 152CR.
6. Remove interseat console lateral panels.

NOTE

Before complying with the following steps make a visual survey of the electrical installations which are present on the A/C since, depending upon A/C configuration, some electrical provisions could be already in the A/C.

7. With reference to Figure 8 install the 150 ft Aural Inhibit structural provision P/N 3G5310A42012, as follows:
 - 7.1 With reference to Figure 8 Section B-B, mark position of two nut plates to be installed on upper deck.
 - 7.2 With reference to Figure 8 Section B-B drill n°2 holes \varnothing 4.27 to 4.39 mm diameter at marked positions and install n°2 nut plates P/N MS21069L08 using n°4 rivets P/N MS20426AD4-3.
8. With reference to Figure 9 thru Figure 14, carry out the 150 ft Aural Inhibit electrical installation P/N 4G2350A04312 or 150 ft Aural Inhibit electrical installation P/N 4G2350A04313, performing the following procedure:
 - 8.1 With reference to Figure 9 thru Figure 14 and Figure 16 Wiring Diagram, disconnect wire F30A20-G, of route B1B245, laid down between PL1P10 connector of the Circuit Breaker panel and J210 sectioning connector in cabin roof. Remove wire F30A20-G or stow it in adjacent area.
 - 8.2 With reference to Figure 10, Figure 13 and Figure 16 Wiring diagram disconnect wire R395A22-G, of route A1B203, laid down between PL27P2 connector of the

- Miscellaneous Control panel in the interseat console and A2-3P2 connector of MAU2 in RH nose. Remove wire R395A22-G or stow it in adjacent area.
- 8.3 With reference to Figure 14 Detail B, install one rail P/N M12883/53-001 with n°2 screws P/N MS24694-S3, on the RH upper deck beam.
 - 8.4 With reference to Figure 14 Detail B, install one relay P/N M83536/2-028M (K163P1) into rail.
 - 8.5 In accordance with AMP DM 39-A-11-00-01-00A-720A-A, install decal P/N ED300K163 adjacent to the relay.
 - 8.6 With reference to Figures 9 through 14 lay down the below-listed cable assemblies, following existing routes as shown in the same Figures:
 - 3G9A01A31601 150 ft Aural Inhibit C/A (A1A316)
 - 3G9A01B32501 150 ft Aural Inhibit C/A (A1B325)
 - 3G9B01B47301 150 ft Aural Inhibit C/A (B1B473)
 - 8.7 With reference to Figure 10, Figure 16 wiring diagram and table on Figure 17 make the electrical connections at A32P1 and A33P1 connectors of the Pilot's MFD and Copilot's MFD, at PL27P2 connector of the Miscellaneous control panel and at P114 and J114 sectioning connectors in RH cockpit floor
 - 8.8 With reference to Figure 13, Figure 16 wiring diagram and table on Figure 17 make the electrical connections at J114 and P114 sectioning connectors in the A/C nose and at A2-3P2 connector of the MAU2.
 - 8.9 With reference to Figure 14 Detail B, Figure 16 wiring diagram and table on Figure 17 make the electrical connections at K163P1 connector of Relay K163. Make sure to protect with Nomex sleeve P/N A582A05 the wire crossing over the existing angle, as shown in Figure 14 Detail B.
 - 8.10 With reference to Figures 11, Figure 14, Figure 16 wiring diagram and table on Figure 17 make the electrical connections at J210 sectioning connector on RH upper beam and at PL1P10 connector of the Circuit Breaker panel.
 - 8.11 Perform a pin-to-pin continuity check to the connection performed.
9. Install interseat console lateral panels.
 10. With reference to AMP DM 39-A-06-41-00-00A-010A-A install cabin floor panels 142AR, 152AR, 140BL, 150AL and RH roof cabin panel 152CR.
 11. With reference to AMP DM 39-A-25-21-01-00A-720A-K or 39-A-25-22-01-00A-720A-K install cabin passenger seats.
 12. Perform a functional test of the MFDs in accordance with Annex A.
 13. With reference to AMP DM 39-A-25-82-04-00A-720A-A install RH hinged lining panels.
 14. In accordance with weight and balance changes, update the Chart A (see Rotorcraft Flight Manual, Part II, section 6).

15. Return the helicopter to flight configuration and record for compliance with Part II of this Service Bulletin on the helicopter logbook.
16. Gain access to My Communications section on Leonardo WebPortal and compile the "Service Bulletin Application Communication".

As an alternative, send the attached compliance form to the following mail box:

engineering.support.lhd@leonardo.com

and (for North, Central and South America) also to:

AWPC.Engineering.Support@leonardocompany.us

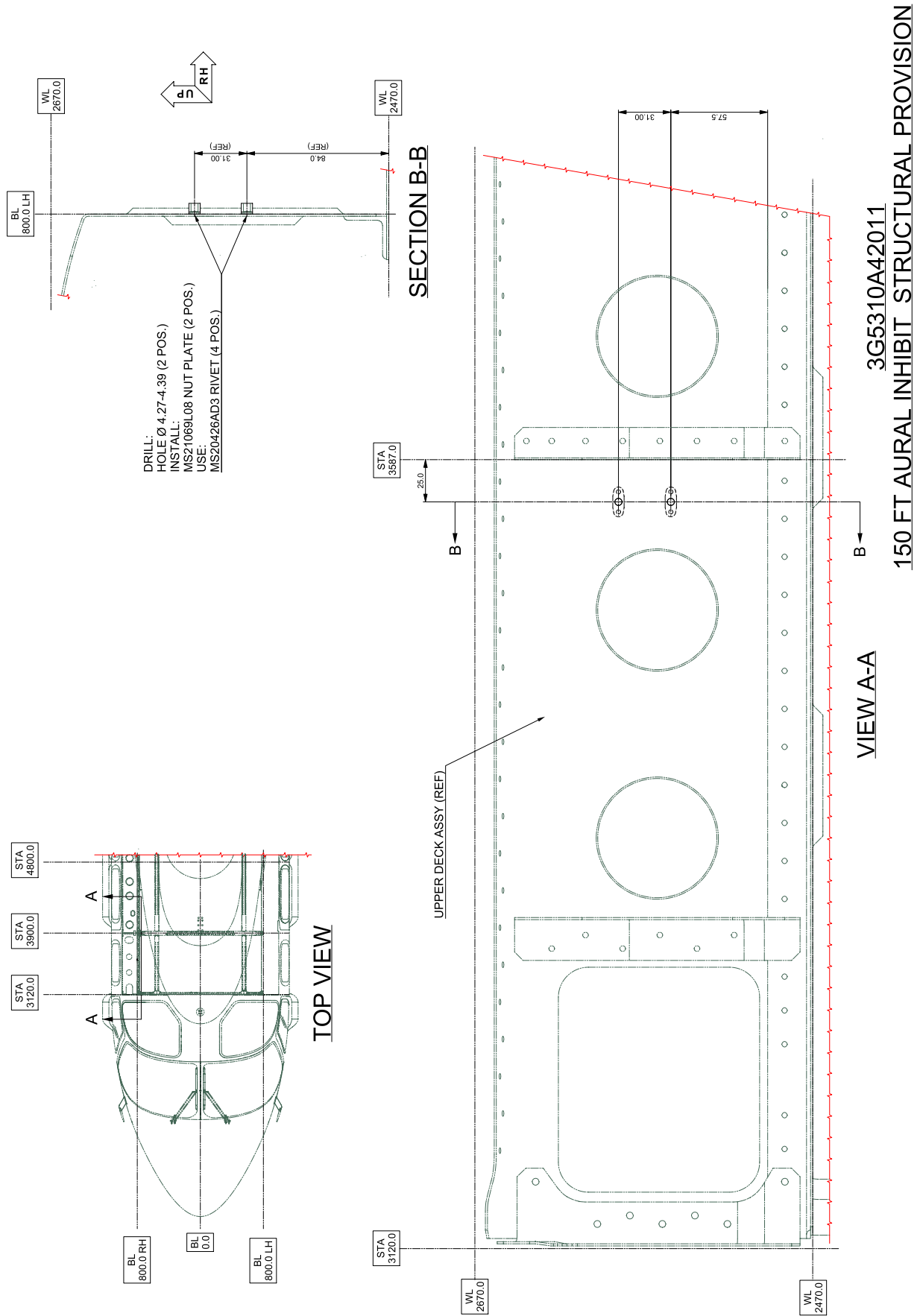

Figure 1

S.B. N°139-677 OPTIONAL
DATE: July 30, 2024
REVISION: /

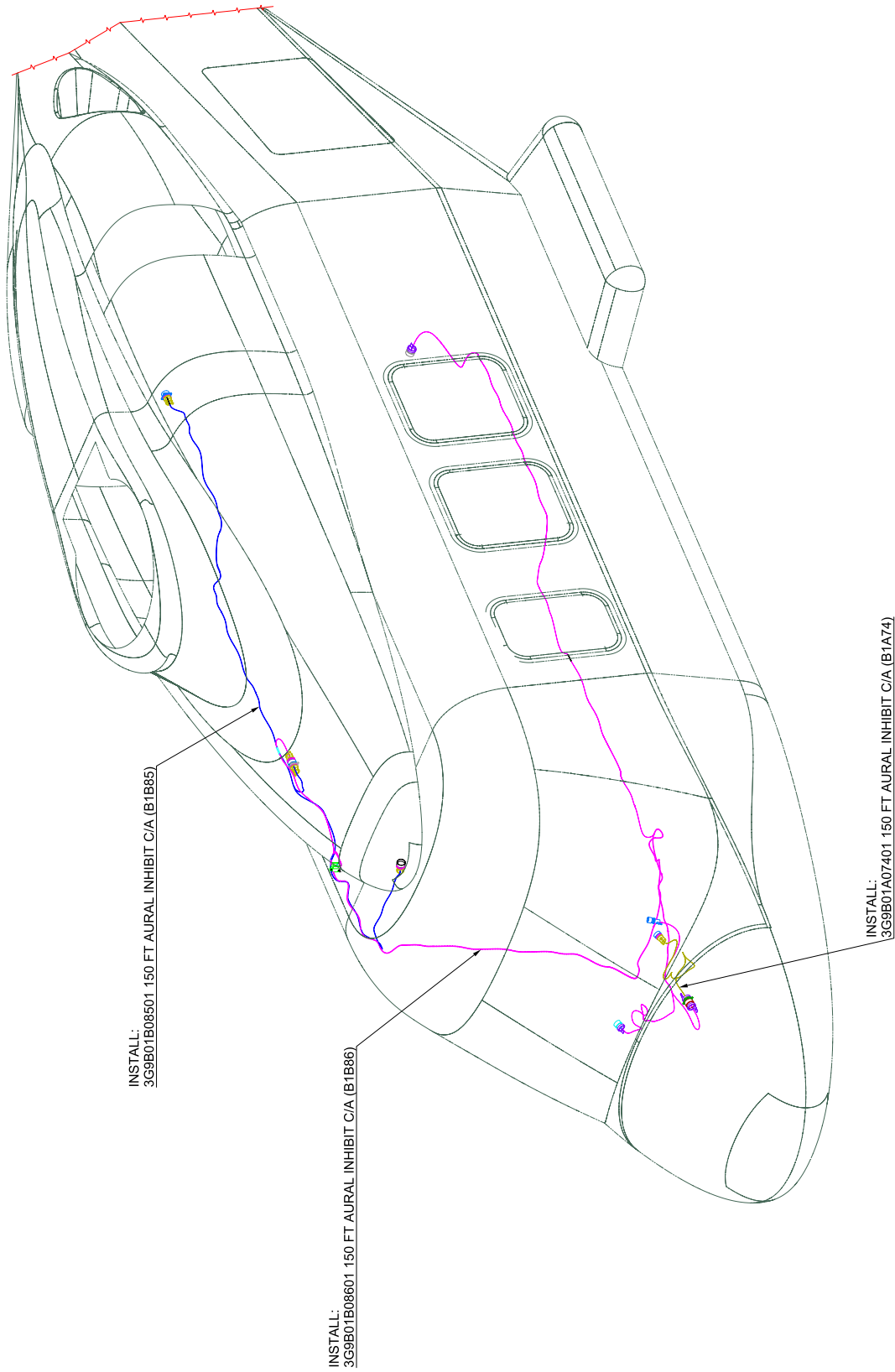
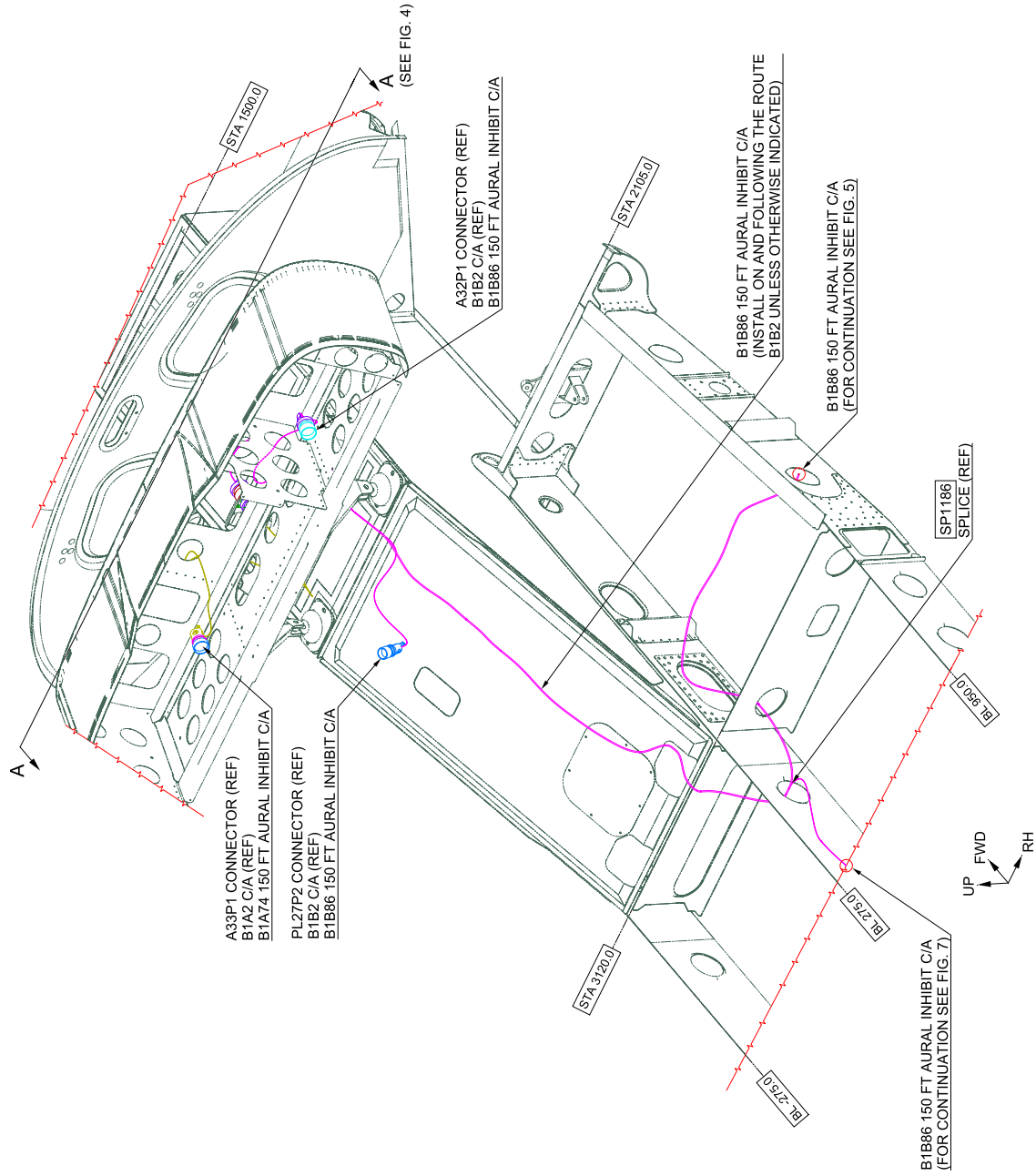

Figure 2



VIEW LOOKING FLOOR AND I/S CONSOLE AREAS TO D.O.F.
 (STRUCTURAL AND SYSTEMS ARE PARTIALLY OMITTED FOR BETTER CLARITY PURPOSE)

Figure 3

S.B. N°139-677 OPTIONAL
 DATE: July 30, 2024
 REVISION: /

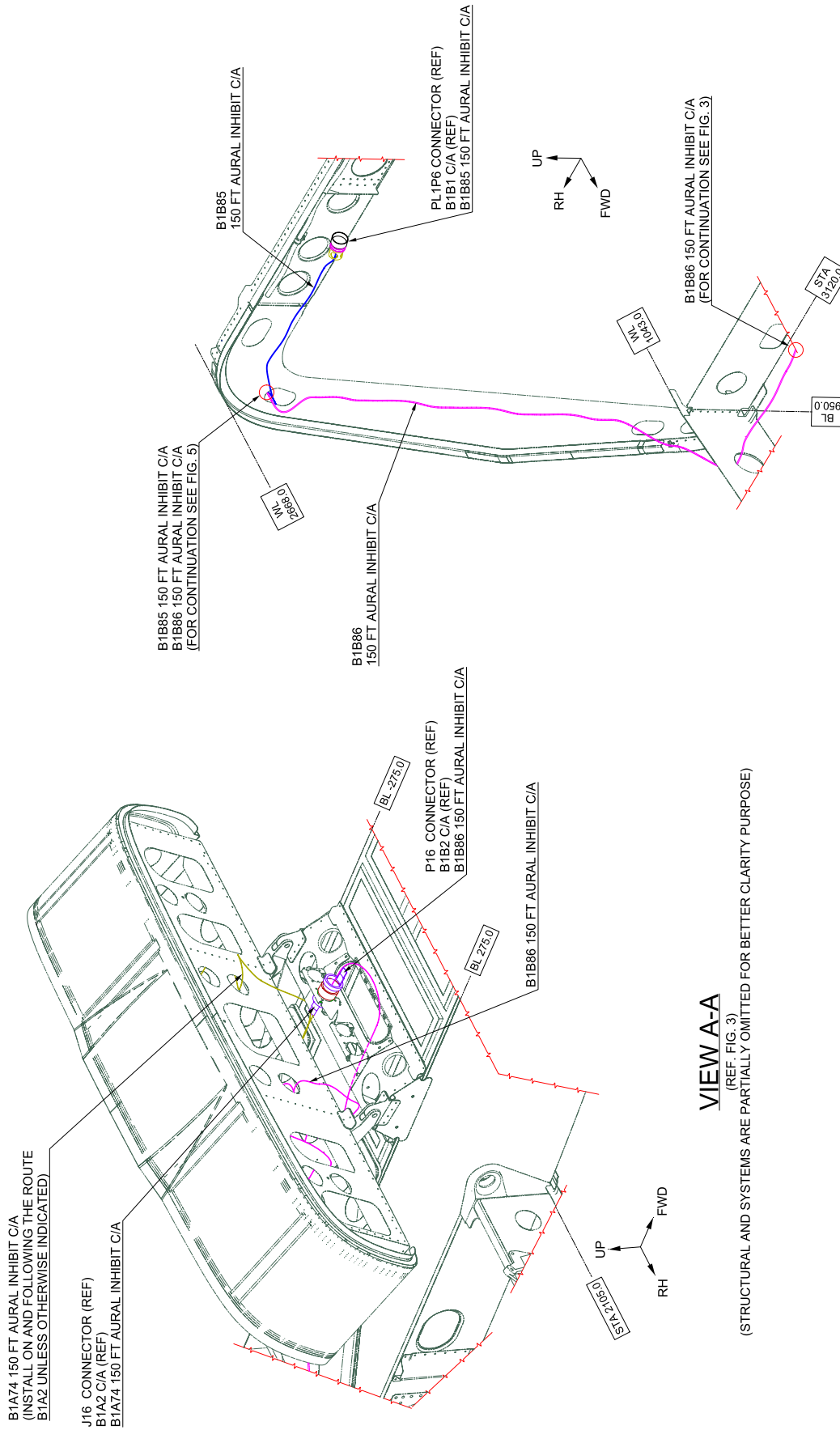

VIEW LOOKING RIGHT OPPOSITE TO D.O.F.
(STRUCTURAL AND SYSTEMS ARE PARTIALLY OMITTED
FOR BETTER CLARITY PURPOSE)

Figure 4

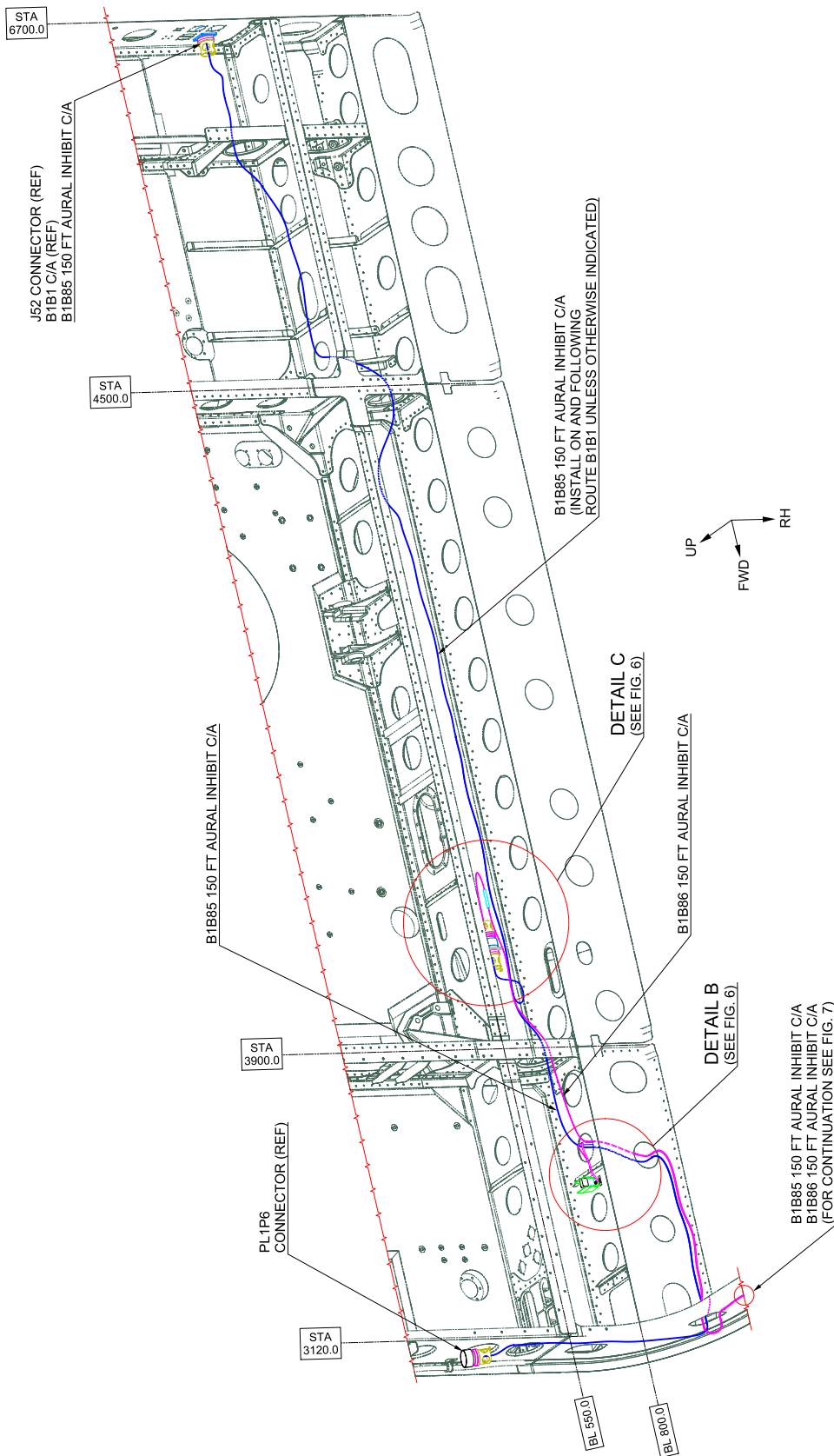

VIEW LOOKING UP RIGHT ROOF AREA OPPOSITE TO D.O.F.
(STRUCTURAL AND SYSTEMS ARE PARTIALLY OMITTED FOR BETTER CLARITY PURPOSE)

Figure 5

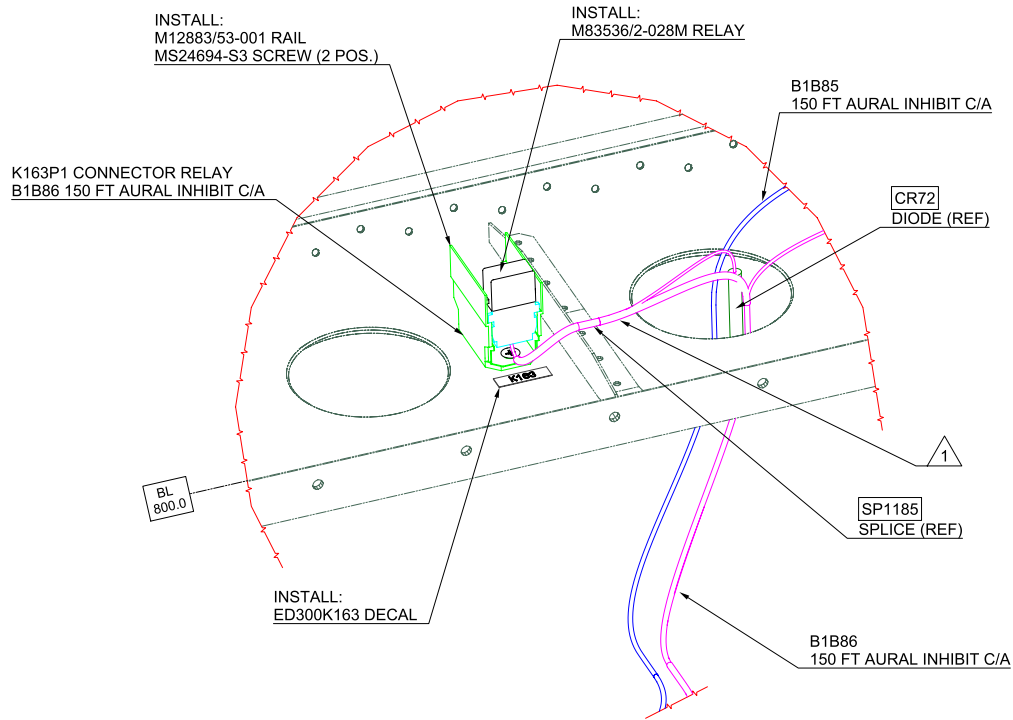

DETAIL B

(REF. FIG. 5)

(STRUCTURAL AND SYSTEMS ARE PARTIALLY OMITTED FOR BETTER CLARITY PURPOSE)

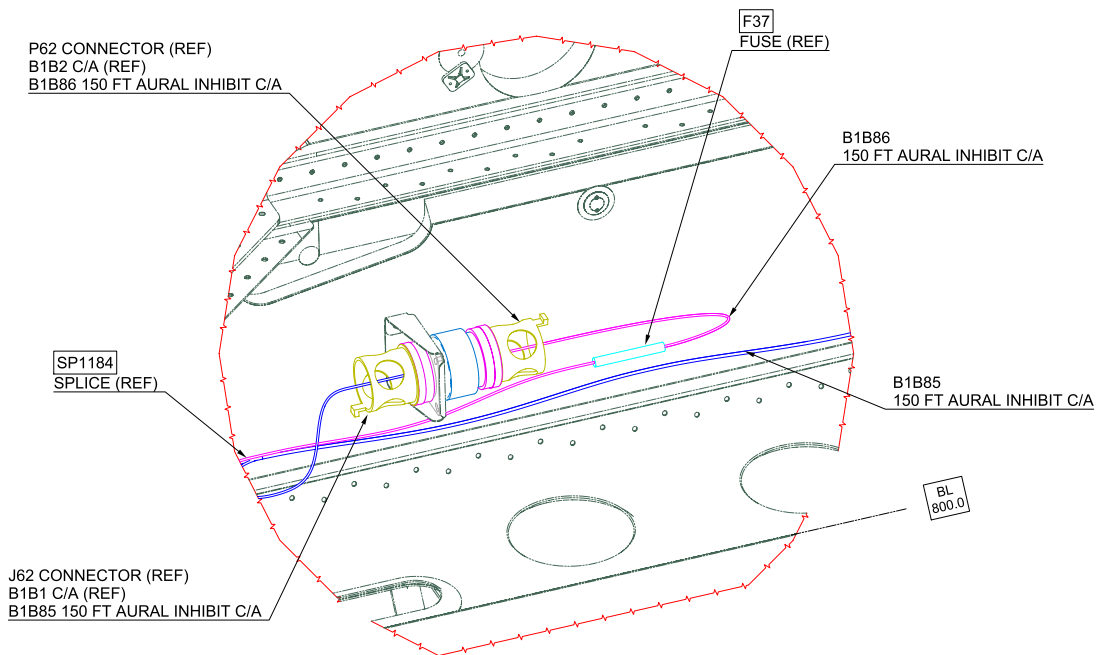

DETAIL C

(REF. FIG. 5)

(STRUCTURAL AND SYSTEMS ARE PARTIALLY OMITTED FOR BETTER CLARITY PURPOSE)

△ - CABLE ASSEMBLY TO BE COVERED WITH A582A05 NOMEX FOR DISTANCE AS SHOWN (140 mm).

Figure 6

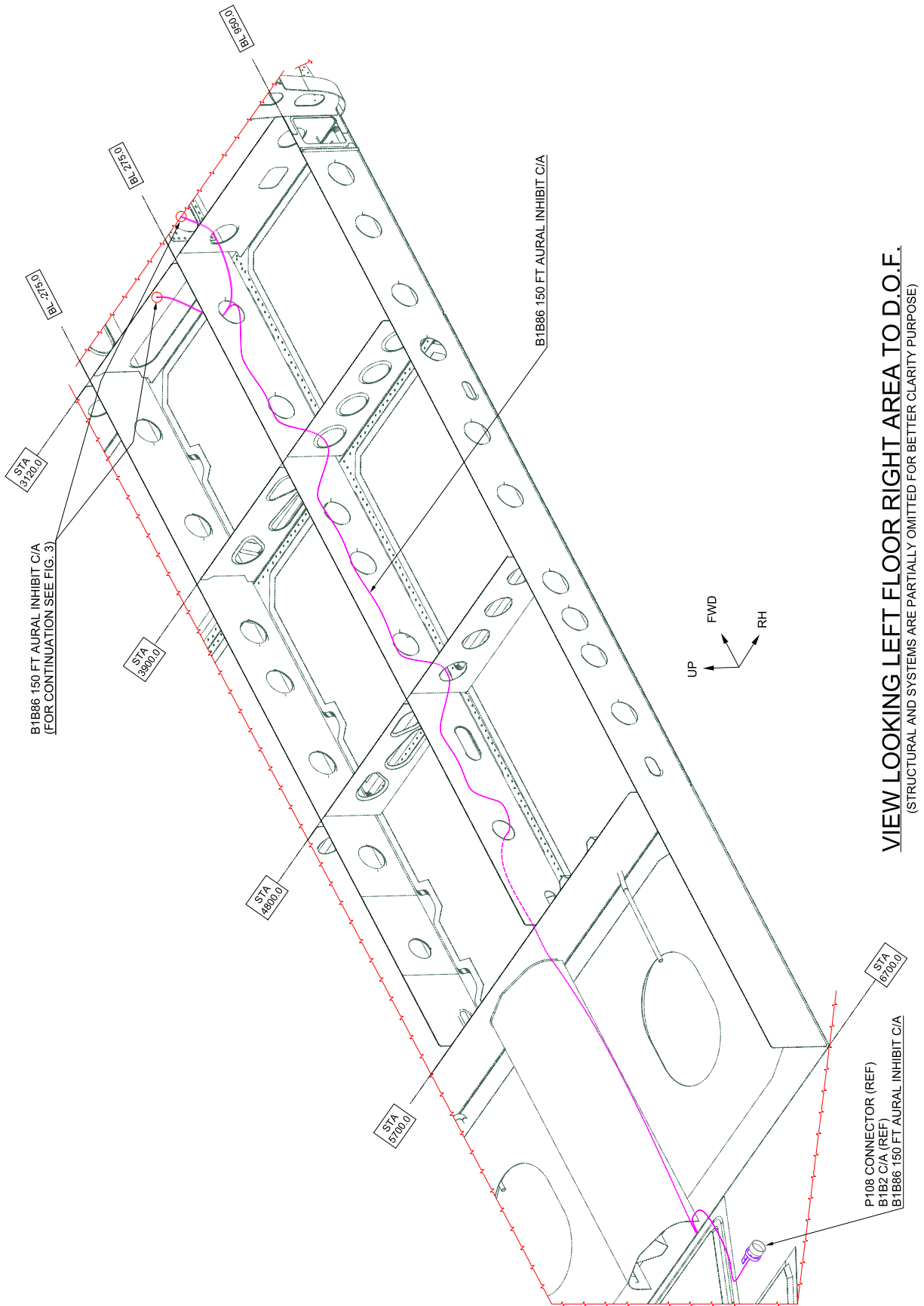

Figure 7

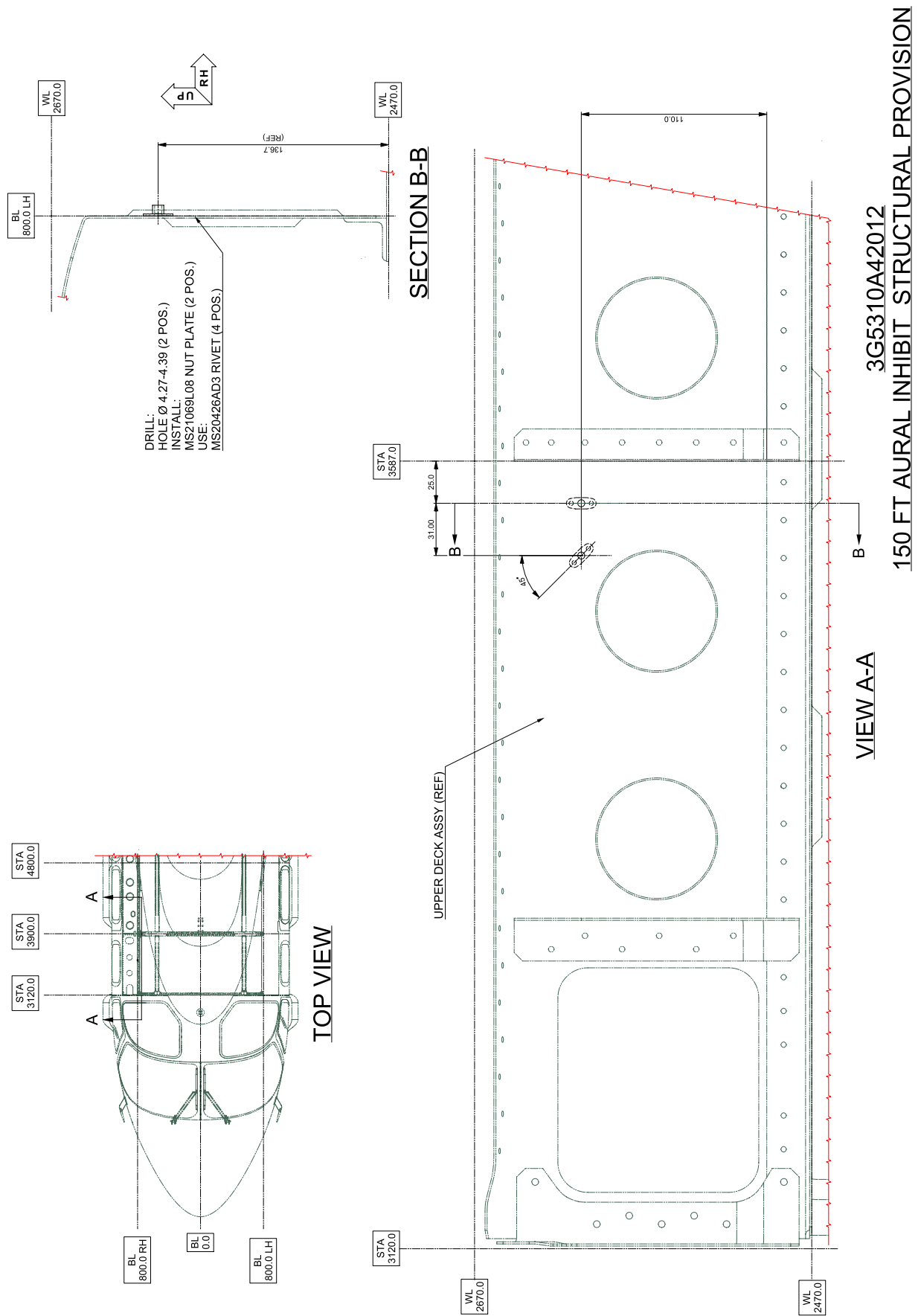

Figure 8

4G2350A04312
150FT AURAL INHIBIT INSTALLATION

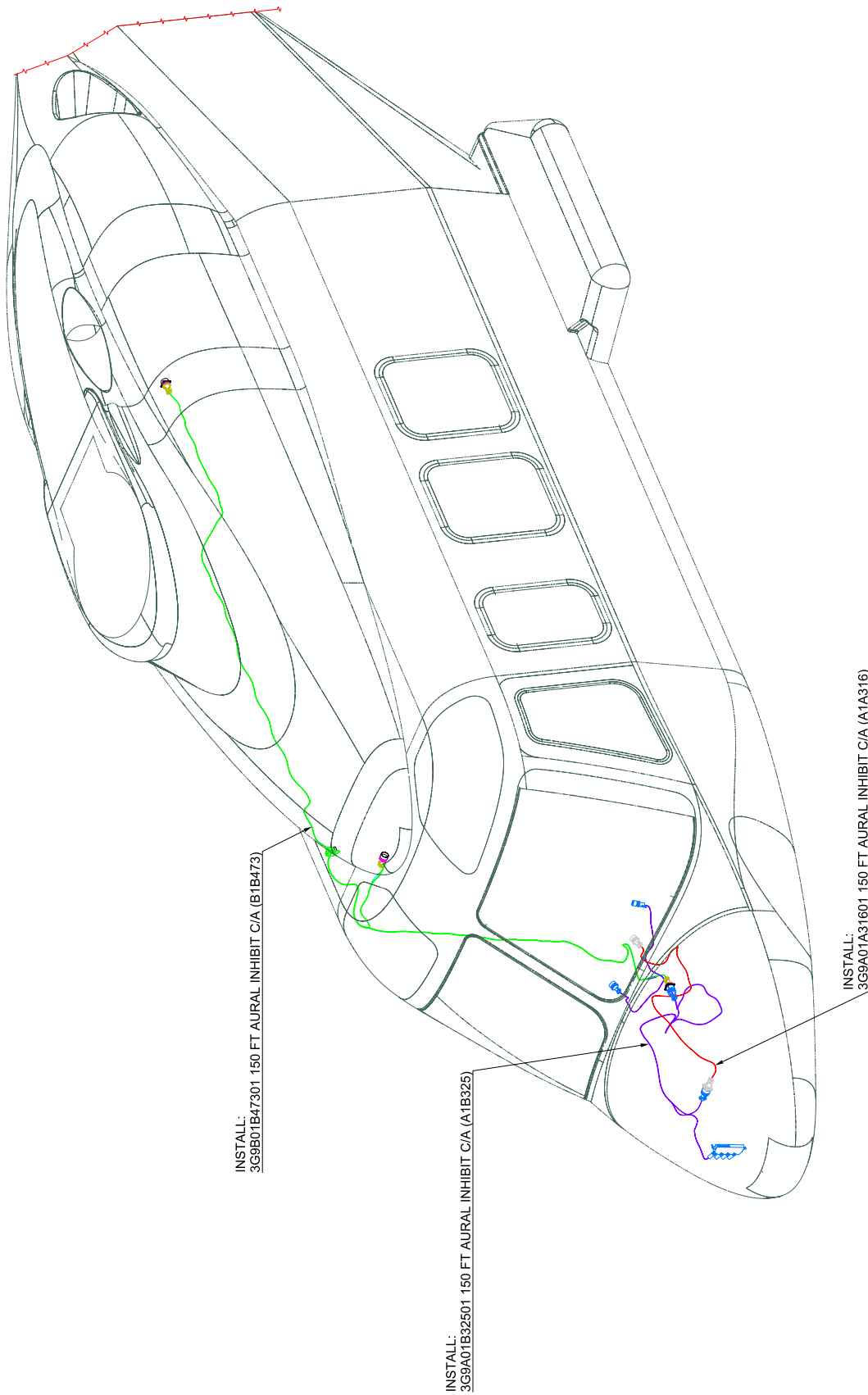
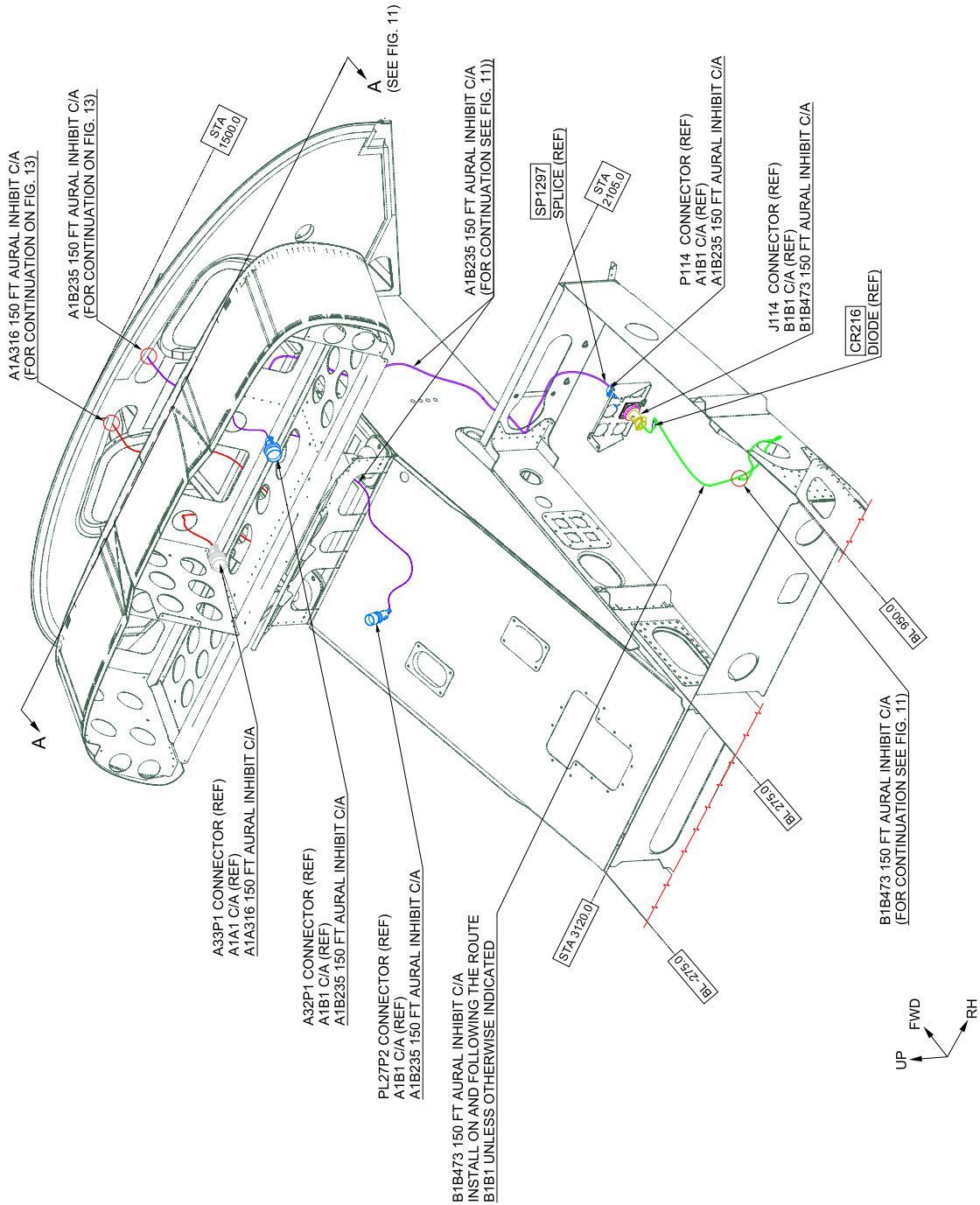

Figure 9

S.B. N°139-677 OPTIONAL
DATE: July 30, 2024
REVISION: /



VIEW LOOKING FLOOR AND I/S CONSOLE AREAS TO D.O.F.

(STRUCTURAL AND SYSTEMS ARE PARTIALLY OMITTED FOR BETTER CLARITY PURPOSE)

Figure 10

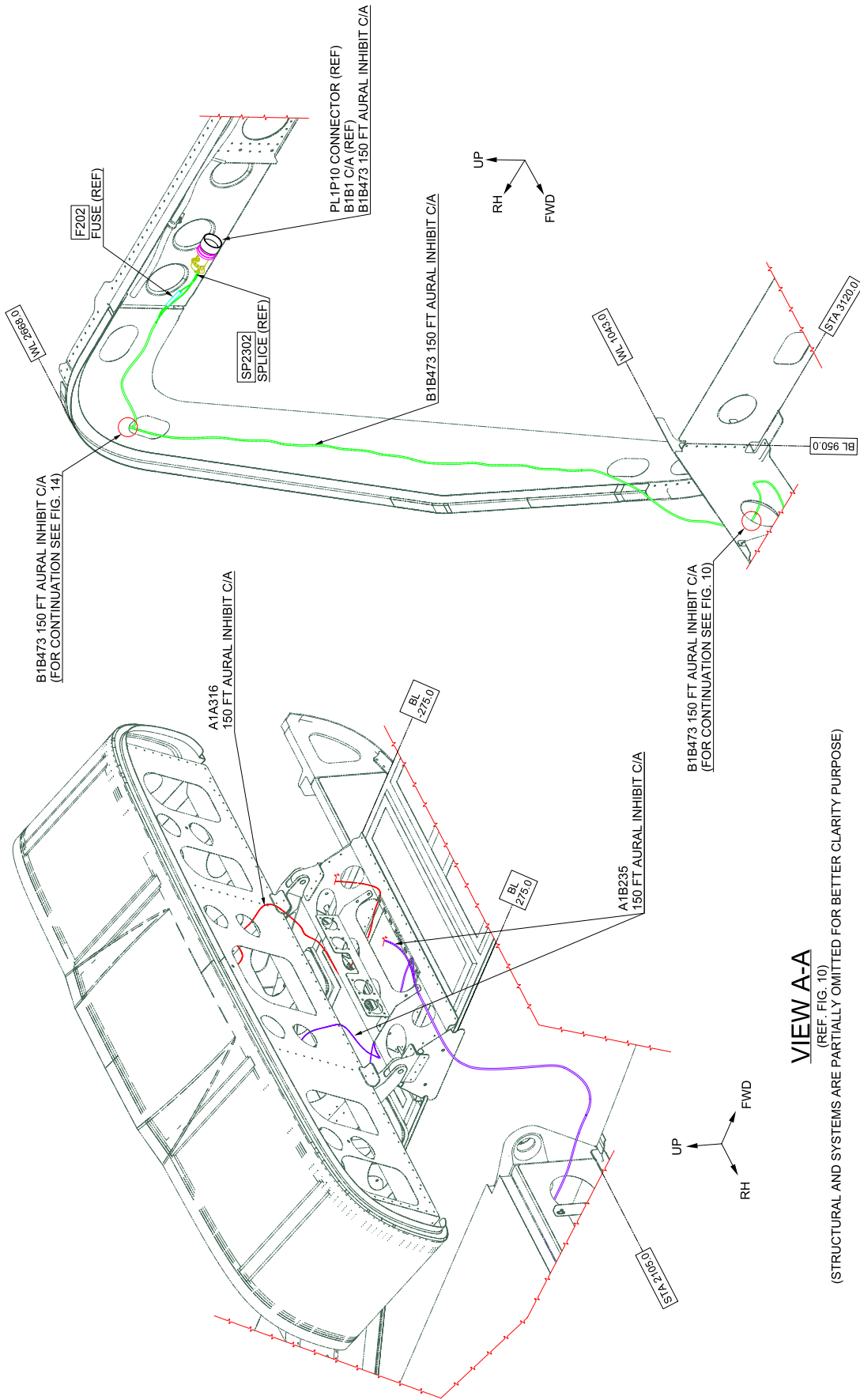

VIEW LOOKING RIGHT OPPOSITE TO D.O.F.
(STRUCTURAL AND SYSTEMS ARE PARTIALLY OMITTED FOR BETTER CLARITY PURPOSE)

VIEW A-A
(REF. FIG. 10)

(STRUCTURAL AND SYSTEMS ARE PARTIALLY OMITTED FOR BETTER CLARITY PURPOSE)

Figure 11

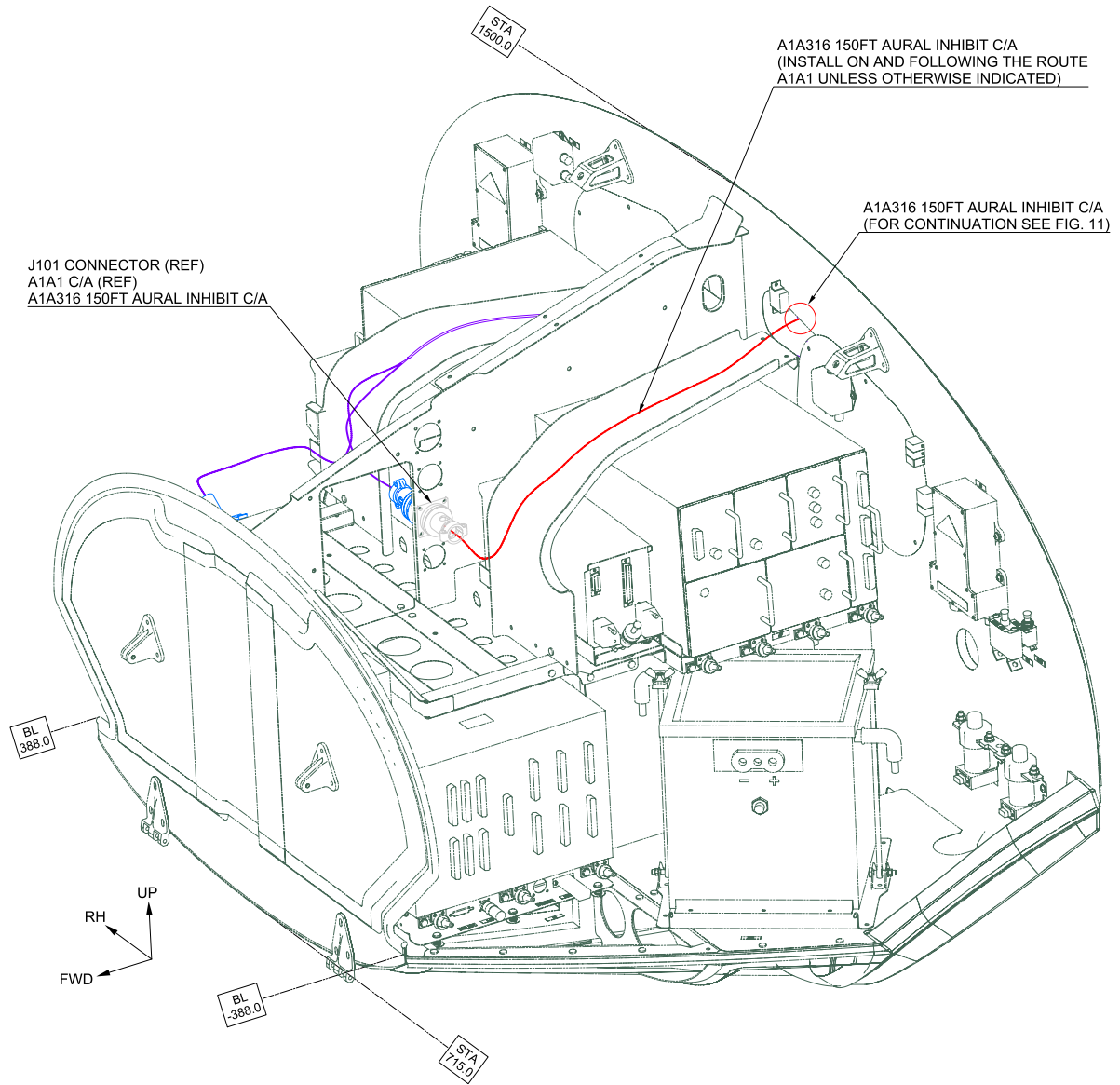

VIEW LOOKING LEFT NOSE AV BAY OPPOSITE D.O.F.
(STRUCTURAL AND SYSTEMS ARE PARTIALLY OMITTED FOR BETTER CLARITY PURPOSE)

Figure 12

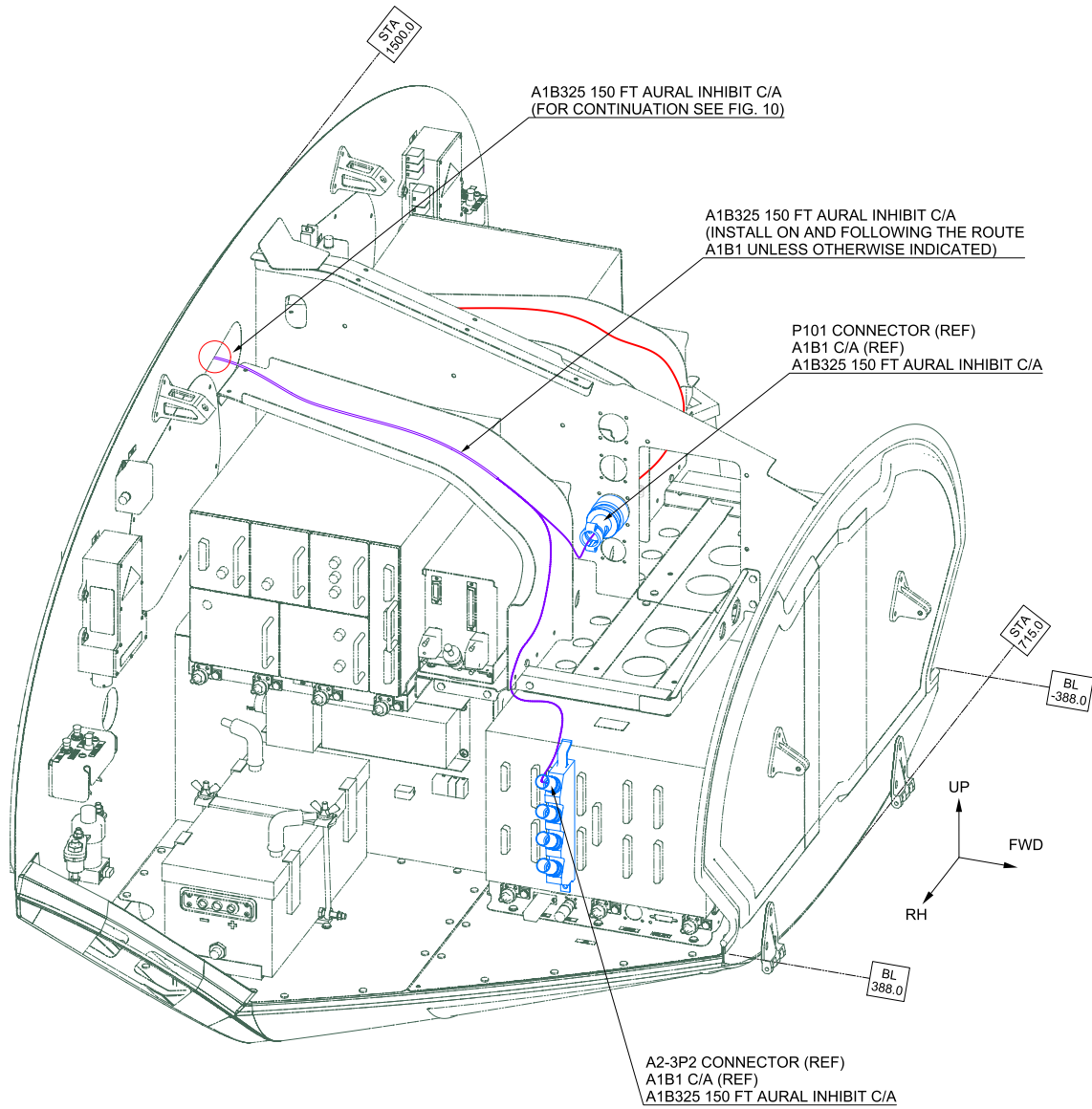

VIEW LOOKING RIGHT NOSE AV BAY OPPOSITE D.O.F.
(STRUCTURAL AND SYSTEMS ARE PARTIALLY OMITTED FOR BETTER CLARITY PURPOSE)

Figure 13

S.B. N°139-677 OPTIONAL
DATE: July 30, 2024
REVISION: /

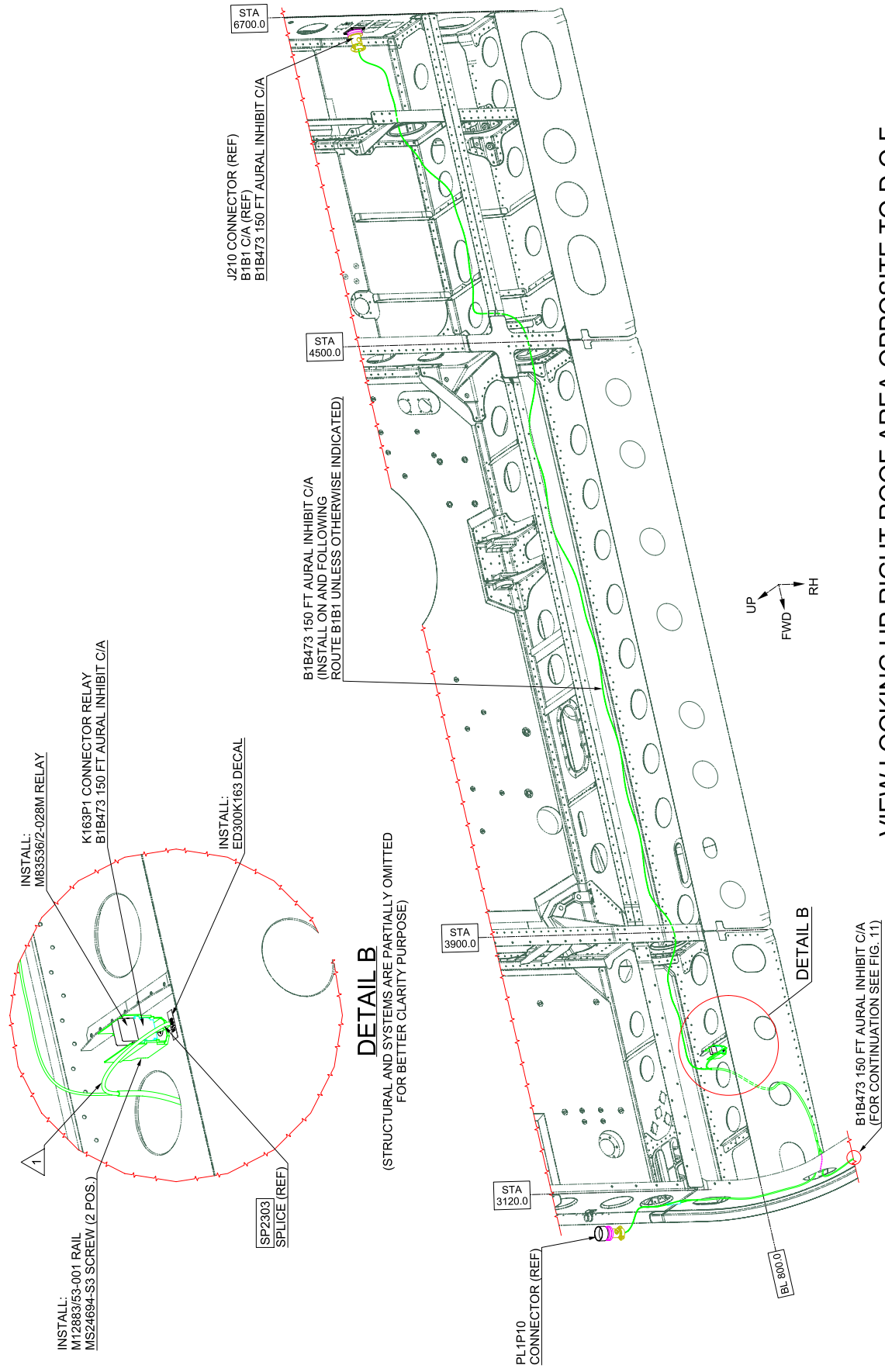
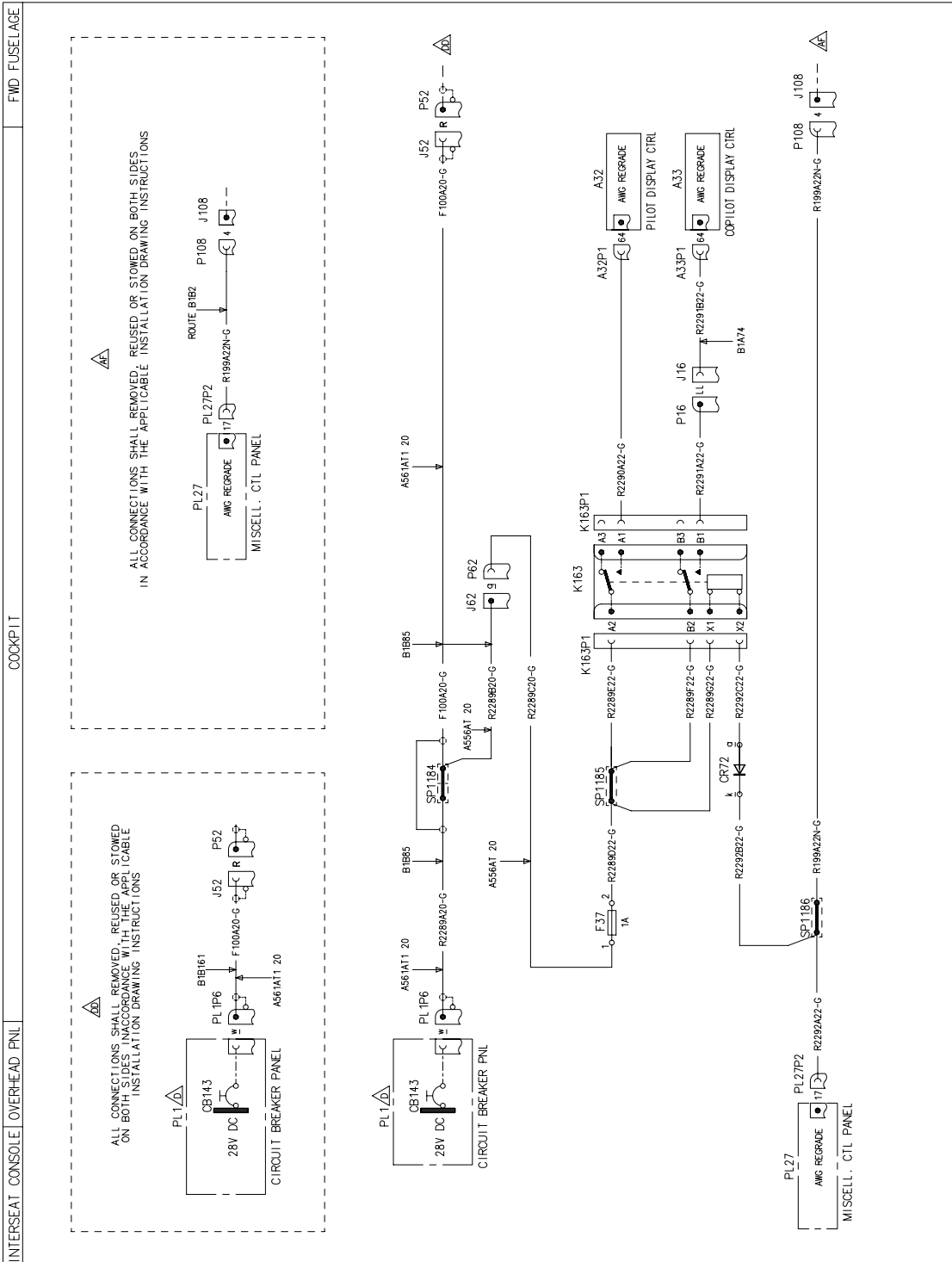

Figure 14



DRAWING REF. KEY
 ICS 322350W001**
 RADIO ALTIMETER 2 323440W002**

3G2350W04901
WIRING DIAGRAM 150FT AURAL INHIBIT

Figure 15

S.B. N°139-677 OPTIONAL
 DATE: July 30, 2024
 REVISION: /

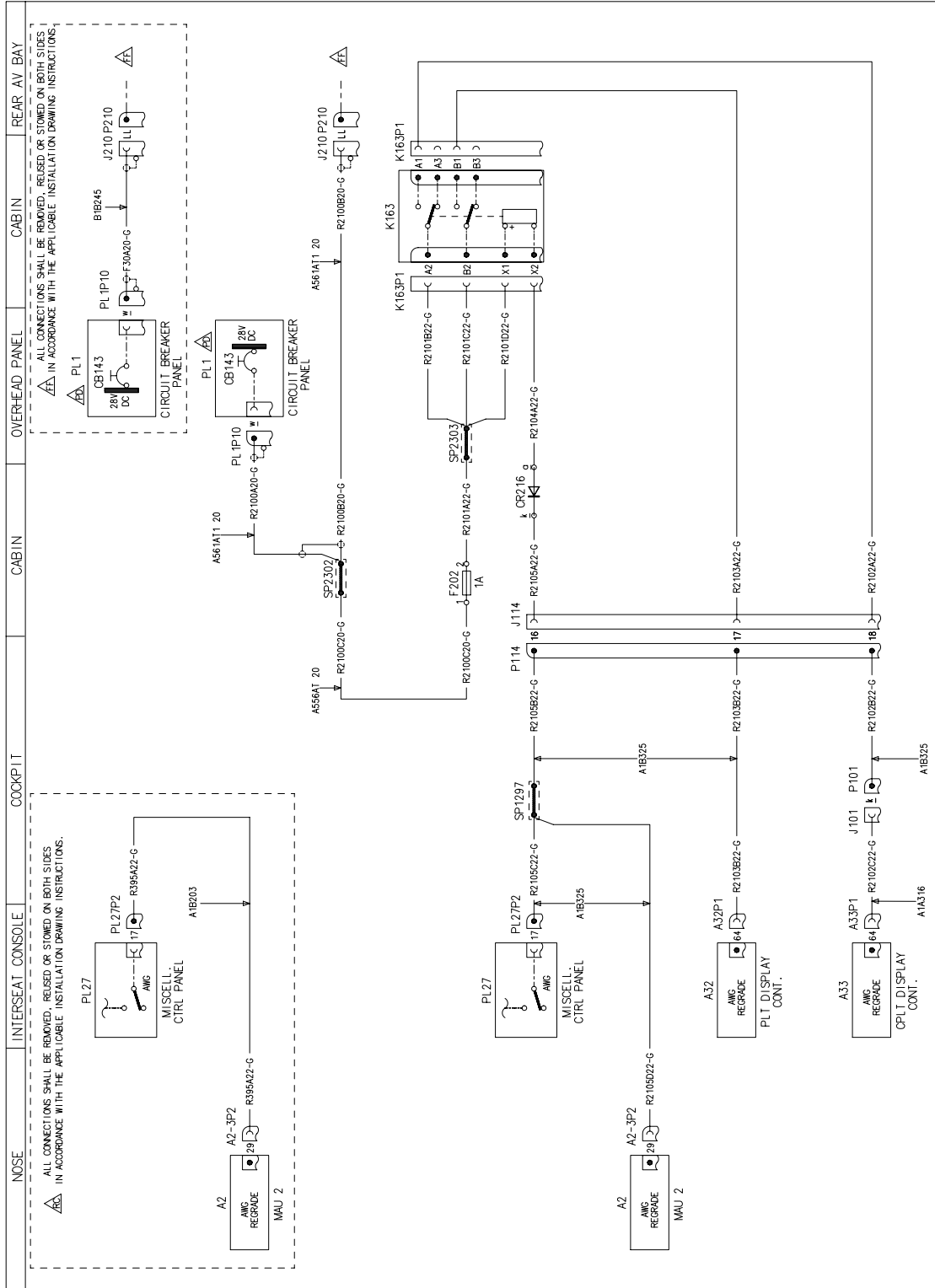

DRAWING REF. KEY
 RADIO ALTIMETER 2
 3G3440W02**
 FEEDER BUSBAR
 3G460001**
 CS
 3G2350W001**

ALL CONNECTIONS SHALL BE REMOVED, REUSED OR STOWED ON BOTH SIDES IN ACCORDANCE WITH THE APPLICABLE INSTALLATION DRAWING INSTRUCTIONS.

FUNCTIONAL NOTES
 ALL CABLES ARE IN LOBBY B60/73 UNLESS SPECIFIED.
 ALL CABLES ARE OF TYPE A566A1 22 UNLESS SPECIFIED.

Figure 16

150 ft aural inhibit electrical installation P/N 4G2350A04311					
Cable Assy	Wire ID	From Ref Des	Electrical Contact	To Ref Des	Electrical Contact
3G9B01A07401 (B1A74)	R2291B22-G	J16	M39029/56-351	A33P1	M39029/57-354
3G9B01B08501 (B1B85)	F100A20-G	SP1184	N.A.	J52	M39029/56-351
	R2289A20-G	PL1P6	M39029/58-363	SP1184	N.A.
	R2289B20-G	SP1184	N.A.	J62	M39029/58-363
3G9B01B08601 (B1B86)	R199A22N-G	SP1186	N.A.	P108	M39029/56-348
	R2289C20-G	P62	M39029/56-351	F37	A523A-A02
	R2289D22-G	F37	A523A-A02	SP1185	N.A.
	R2289E22-G	SP1185	N.A.	K163P1	M39029/101-553
	R2289F22-G	SP1185	N.A.	K163P1	M39029/101-553
	R2289G22-G	SP1185	N.A.	K163P1	M39029/101-553
	R2290A22-G	K163P1	M39029/101-553	A32P1	M39029/57-354
	R2291A22-G	K163P1	M39029/101-553	P16	M39029/58-363
	R2292A22-G	SP1186	N.A.	PL27P2	M39029/56-348
	R2292B22-G	SP1186	N.A.	CR72	A523A-A02
	R2292C22-G	K163P1	M39029/101-553	CR72	A523A-A02

150 ft aural inhibit electrical installation P/N 4G2350A04312 or 4G2350A04313					
Cable Assy	Wire ID	From Ref Des	Electrical Contact	To Ref Des	Electrical Contact
3G9A01A31601 (A1A316)	R2102C22-G	A33P1	M39029/57-354	J101	M39029/56-351
3G9A01B32501 (A1B325)	R2102B22-G	P101	M39029/58-363	P114	M39029/58-360
	R2103B22-G	A32P1	M39029/57-354	P114	M39029/58-360
	R2105B22-G	SP1297	N.A.	P114	M39029/58-360
	R2105C22-G	PL27P2	M39029/56-348	SP1297	N.A.
	R2105D22-G	SP1297	N.A.	A2-3P2	M39029/57-354
3G9B01B47301 (B1B473)	R2100A20-G	PL1P10	M39029/58-363	SP2302	N.A.
	R2100B20-G	J210	M39029/56-352	SP2302	N.A.
	R2100C20-G	SP2302	N.A.	F202	A523A-A02
	R2101A22-G	F202	A523A-A02	SP2303	N.A.
	R2101B22-G	SP2303	N.A.	K163P1	M39029/101-553
	R2101C22-G	SP2303	N.A.	K163P1	M39029/101-553
	R2101D22-G	SP2303	N.A.	K163P1	M39029/101-553
	R2102A22-G	K163P1	M39029/101-553	J114	M39029/56-348
	R2103A22-G	J114	M39029/56-348	K163P1	M39029/101-553
	R2104A22-G	K163P1	M39029/101-553	CR216	A523A-A02
R2105A22-G	J114	M39029/56-348	CR216	A523A-A02	

Figure 17

ANNEX A

150 FT AURAL INHIBIT INSTALLATION FUNCTIONAL TEST

1. Perform the functional test of the 150 Ft Aural inhibition in the following way:
2. Safety Provisions:
 - 2.1 Disconnect the plug connectors from the Fire Extinguishing bottles and properly stow.
 - 2.2 If other Electro-Explosive Devices (EED) are fitted, make sure that are electrically disconnected.
 - 2.3 Do not handle or operate plug/receptacle connectors with voltage presence.
3. Tools Required.
 - 3.1 DC external power bench (28 VDC)
 - 3.2 Test box, MLG microswitches P/N 3G3200G00131 (AJ-06-00).
 - 3.3 Goodrich Landing Gear: Adapter cable, WOW test box P/N 3G3200G00431 (GK-09-00).
4. Test prerequisite:
 - 4.1 Verify that the External Power Bench is operative and set to the appropriate voltage (28VDC).
 - 4.2 During Functional test keep the AUX battery plugged to preserve the CMC module.
 - 4.3 Before starting Functional test make a final visual inspection of the correct installation of the Avionic equipment removed/installed.
 - 4.4 Make sure from A/C records that the installation of Primus Epic ® Phase 4 Software release 4.8 or higher, was successfully completed.
 - 4.5 Pull out 1-2 START and 1-2 IGN Circuit Breakers.
 - 4.6 Power on the A/C and verify that:
 - 4.6.1 The Caution "SYS CONFIG FAIL" is not displayed in the CAS list.
 - 4.6.2 The Caution "AVIONIC FAULT" is not displayed in the CAS list.
 - 4.6.3 In the SYS CONFIG page verify that the required SETTINGS have been installed.
5. Functional Test:
 - 5.1 Pull out RAD ALT 1 and RAD ALT 2 Circuit breakers.
 - 5.2 Set the WOW switch to the "FLIGHT" position.
 - 5.3 Set the decision height (DH) to 200 feet value by the DH selection knob on the Pilot Remote Instrument Controller (If Phase 5 is installed, set the pilot's PFD as PFD 2 "On command").
 - 5.4 Set the LOW HT AWG switch on the Miscellaneous Control panel to the INHIBIT position (Or the AWG switch to REGRADE, if Miscellaneous Control panel P/N 3G3110V00351 or P/N 3G3110V00352 is installed).
 - 5.5 Push in RAD ALT 2 circuit breaker again:

- The indicated Radar altitude decreases from the maximum value to 0 feet.
- 5.6 Verify the Status Message “150 FEET AURAL INHIBIT” is displayed on CAS list.
 - 5.7 Set the LOW HT AWG switch on the Miscellaneous Control panel to NORM position (Or the AWG switch to NORM, if Miscellaneous Control panel P/N 3G3110V00351 or P/N 3G3110V00352 is installed).
 - 5.8 Verify the Status Message “150 FEET AURAL INHIBIT” disappears from CAS list.
 - 5.9 Pull out the RAD ALT 2 Circuit Breaker.

