

ALERT SERVICE BULLETIN

TITLE: Servo-control system - Check of the connection between the upper ball bearing end and the main rotor servo-control

SB Type: Protective measure

APPLICABILITY

Model:	AS365
Helicopters affected:	F , Fi , Fs , K , K2 , N , N1 , N2 , N3
Component affected:	SC8031 and SC8031-1 and SC8031-2 and SC8031A and SC8032 and SC8032-1 and SC8032-2 and SC8033-1 and SC8033-2 and SC8034-1 and SC8034-2

COMPLIANCE: MANDATORY

Comply with this ALERT SERVICE BULLETIN not more than 110 flight hours or 6 months (the first limit you get to is applicable) after you received issue 001 of this ALERT SERVICE BULLETIN.

SUMMARY

The purpose of this ALERT SERVICE BULLETIN is to check the nut tightening torque of the upper ball bearing end of the main rotor servo-controls.

REVISION REASON

Reason for issue 002

The purpose of issue 002 of this ALERT SERVICE BULLETIN is to update the Response form and add a reporting request to Airbus Helicopters technical support if a tightening torque value less than 2 daN.m (177 lbf.in) has been detected during the check of the nut tightening torque.

Issue 002 of this ALERT SERVICE BULLETIN has no effect on the compliance with issue 001 of this ALERT SERVICE BULLETIN.

[Export Control:](#)

[US Export Control - No US content. This Item does not contain any U.S. origin ITAR or EAR content.](#)

[FR Export Control - Not Listed. This Item is not listed against the EC regulations in the EU/FR.](#)

ASB AS365-67-30-0001

Issue 001 2024-04-18
Issue 002 2024-05-15

Additional work

If a tightening torque value less than 2 daN.m (177 lbf.in) was detected, send a report to Airbus Helicopters technical support.

GENERAL EVALUATION

Evaluation table			
Perform once	YES	Recurring accomplishment	NO

GENERAL ILLUSTRATION

ASB AS365-67-30-0001

Issue 001 2024-04-18
Issue 002 2024-05-15

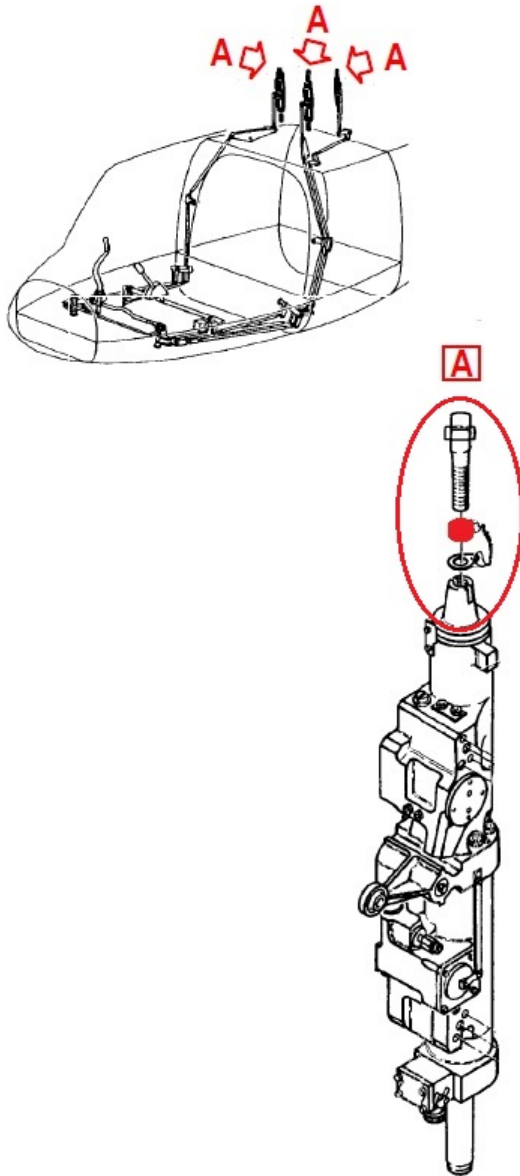

PLANNING INFORMATION

1. REASON



Airbus Helicopters was informed of two cases of loss of tightening torque between an upper ball bearing end and a main rotor servo-control. One case led to the disconnection of these two parts. In this case, the crew detected a vibration and hardening of the collective pitch lever on the ground when the collective pitch was increased.

After investigation, it turns out that there is no requirement to monitor the tightening torque of the upper ball bearing end in service.

Consequently, the purpose of this ALERT SERVICE BULLETIN is to check the nut tightening torque of the upper ball bearing end of the main rotor servo-controls and to collect information regarding the fleet status.

2. DESCRIPTION

This ALERT SERVICE BULLETIN includes the work steps that follow for each main rotor servo-control:

- Check of the nut tightening torque of the upper ball bearing end
- Check condition of threads of the main rotor servo-control if the nut tightening torque of the upper ball bearing end is out of tolerance.

3. CONCURRENT REQUIREMENTS

Not applicable.

4. APPROVAL

The technical content of this document is approved under the authority of the Design Organization Approval ref. EASA. 21J.700.

The technical content of this document is approved under the prerogatives of the recognition of design capability ref. FRA21J-002-DGA for French Government helicopters.

The technical content of this document is approved by Airbus Helicopters Airworthiness Department for export military versions.

5. MANPOWER

NOTE

The Purpose of Man Hours is to give Airbus Helicopters customers a guideline for maintenance scheduling. It is not a contractual information.

5.1. Manpower for the check of the nut tightening torque of the upper ball bearing end

Number of Persons	Qualification	Estimated Man Hours
1	Mechanical technician	1h

5.2. Manpower for the condition check of the threads of one main servo-control

Number of Persons	Qualification	Estimated Man Hours
1	Mechanical technician	1h

5.3. Manpower for set up and close up

Number of Persons	Qualification	Estimated Man Hours
1	Mechanical technician	0.5h

6. WEIGHT AND BALANCE

There is no change in weight and moment.

7. ELECTRICAL LOAD DATA

Not changed.

8. DOCUMENTATION AFFECTED

Not applicable.

9. MATERIAL INFORMATION

9.1. Price

For information about the price of the modification kits and/or components, or for aid, contact the Airbus Helicopters Network Sales and Customer Relations Department.

9.2. Availability

Contact the Sales and Customer Relations Department to know the delivery lead times.

9.3. Procurement

Send an order for the necessary quantities to the Airbus Helicopters Network Sales Department:

Airbus Helicopters
Etablissement de Marignane
Direction des Ventes et Relations Client
13725 MARGNANE CEDEX FRANCE

In the purchase order, write the information that follows:

- The mode of transport
- The destination
- The serial numbers of the helicopters to change.

You can order the consumables from the AirbusWorld Marketplace through e-ordering (IN No. 3481-I-00). If you cannot get access to e-ordering, please contact your Logistic Focal Point.

9.4. Mixability

This Service Bulletin has no effect on the mixability.

9.5. LIST OF NEW MATERIALS

For routine replacement parts, refer to the Work Cards specified in this ALERT SERVICE BULLETIN and the list below

Individual Spares List				
Item	Designation	Reference	MFC	QTY
1	Ball bearing end	EMRL8RSP3D	F0222	AR
2	Ball bearing end	EMRL8RSP3C	F0234	AR
3	Ball bearing end	6701800800	F0210	AR
4	Main rotor servo-control	SC8034-2	F0210	AR
9	Main rotor servo-control	SC8034-1	F0210	AR
10	Main rotor servo-control	SC8033-2	F0210	AR
11	Main rotor servo-control	SC8033-1	F0210	AR
12	Main rotor servo-control	SC8032-2	F0210	AR
13	Main rotor servo-control	SC8032-1	F0210	AR
14	Main rotor servo-control	SC8032	F0210	AR
15	Main rotor servo-control	SC8031A	F0210	AR
16	Main rotor servo-control	SC8031-2	F0210	AR
17	Main rotor servo-control	SC8031-1	F0210	AR
18	Main rotor servo-control	SC8031	F0210	AR

For consumables, refer to the Work Cards specified in this ALERT SERVICE BULLETIN and the list below:

Consumables, Materials and Expendables			
Designation	Reference	MFC	QTY
Sealing compound	CM6068	F0210	AR
Sealant	CM518	F0210	AR
Cleaning agent	CM208	F0210	AR
Lock-wire	CM776	F0210	AR

Special Tools				
Item	Designation	Reference	MFC	QTY
7	Flashlight	Commercial reference		1
8	Articulated mirror	Commercial reference		1

9.6. LIST OF EXISTING PARTS

Not applicable.

10. ACCOMPLISHMENT INSTRUCTION

Comply with the accomplishment procedure [67-30-0001, 933](#)

11. ADDITIONAL INFORMATION

Not applicable.

End of section

ACCOMPLISHMENT PROCEDURE 67-30-0001, 933

1. APPLICABILITY

Model:	AS365
Helicopters affected:	F , Fi , Fs , K , K2 , N , N1 , N2 , N3
Component affected:	SC8031 and SC8031-1 and SC8031-2 and SC8031A and SC8032 and SC8032-1 and SC8032-2 and SC8033-1 and SC8033-2 and SC8034-1 and SC8034-2

2. GENERAL INFOS

Acronym / Abbreviation List

AR - As Required

ASB - ALERT SERVICE BULLETIN

daN.m - deca Newton meter

FM - Fiche Matricule (Log card)

FOD - Foreign Object Damage

IN - Information Notice

lbf.in - pound force inch

MET - Manuel d'Entretien (Maintenance Manual)

MTC - Manuel des Techniques Courantes (Standard Practices Manual)

SPN - Safety Promotion Notice

3. PRELIMINARY REQUIREMENTS

3.1. Applicable Documents

- GENERAL - In need of your Technical Support? Contact us 24/7/365! IN 3041-I-00
- GENERAL - The Marketplace: an AirbusWorld eOrdering service IN 3481-I-00
- Introduction of the digital Service Bulletin reporting service SB Insight IN 3785-I-00
- GENERAL - Foreign Object Damage prevention SPN 3703-P-00
- Handling - Handling of helicopters in a hangar and in a prepared area [MTC 20-07-01-201](#)
- Drafting and updating the log card (FM) - General rules applicable to aircraft [MTC 20-08-05-101](#)
- General Instructions - Rotors flight controls [MET 67-00-00-301](#)
- Assembly by screws and nuts - Joining [MTC 20-02-05-404](#)
- Use of cleaning products on individual parts and on helicopters - Cleaning [MTC 20-04-01-102](#)
- Removal / Installation - Main rotor actuators - Main servo-controls [MET 67-30-10-401](#)
- MGB cowlings: Removal / Installation - Cowlings and fairings [MET 53-50-00-401](#)

3.2. Set up

- Park the helicopter in a hangar. Refer to Work Card Handling - Handling of helicopters in a hangar and in a prepared area [MTC 20-07-01-201](#)
- Disconnect all the electrical power supplies.
- Install the applicable access equipment.
- Remove the MGB cowlings. Refer to Work Card MGB cowlings: Removal / Installation - Cowlings and fairings [MET 53-50-00-401](#)

3.3. Special tools

Designation	Reference	QTY
Flashlight	Commercial reference	1
Articulated mirror	Commercial reference	1

3.4. Materials

Designation	Reference	MFC	QTY
Sealing compound	CM6068	F0210	AR
Sealant	CM518	F0210	AR
Cleaning agent	CM208	F0210	AR

ASB AS365-67-30-0001

Issue 001 2024-04-18
Issue 002 2024-05-15

Designation	Reference	MFC	QTY
Lock-wire	CM776	F0210	AR

3.5. Spares

Designation	Reference	MFC	QTY
Ball bearing end	EMRL8RSP3D	F0222	AR
Ball bearing end	EMRL8RSP3C	F0234	AR
Ball bearing end	6701800800	F0210	AR
Main rotor servo-control	SC8034-2	F0210	AR
Main rotor servo-control	SC8034-1	F0210	AR
Main rotor servo-control	SC8033-2	F0210	AR
Main rotor servo-control	SC8033-1	F0210	AR
Main rotor servo-control	SC8032-2	F0210	AR
Main rotor servo-control	SC8032-1	F0210	AR
Main rotor servo-control	SC8032	F0210	AR
Main rotor servo-control	SC8031A	F0210	AR
Main rotor servo-control	SC8031-2	F0210	AR
Main rotor servo-control	SC8031-1	F0210	AR
Main rotor servo-control	SC8031	F0210	AR

3.6. Safety conditions

WARNING

**BEFORE YOU START THE WORK, READ THE SAFETY AND
GENERAL MAINTENANCE INSTRUCTIONS OF TASK
GENERAL INSTRUCTIONS - ROTORS FLIGHT CONTROLS
[MET 67-00-00-301](#)**

CAUTION

**MAKE SURE THAT YOU PREVENT ALL POSSIBLE FOD.
REFER TO SAFETY PROMOTION NOTICE No. 3703-P-00.**

4. PROCEDURE

- 4.1. Only the procedure for the left rear main rotor servo-control is given. Do the same procedure for the left front main rotor servo-control and the right front main rotor servo-control, unless differently specified.
- 4.2. Do a check of the nut (5) tightening torque of the Ball bearing end EMRL8RSP3D (1) or Ball bearing end EMRL8RSP3C (2) or Ball bearing end 6701800800 (3) of the Main rotor servo-control SC8034-2 (4) or Main rotor servo-control SC8034-1 (9) or Main rotor servo-control SC8033-2 (10) or Main rotor servo-control SC8033-1 (11) or Main rotor servo-control SC8032-2 (12) or Main rotor servo-control SC8032-1 (13) or Main rotor servo-control SC8032 (14) or Main rotor servo-control SC8031A (15) or Main rotor servo-control SC8031-2 (16) or Main rotor servo-control SC8031-1 (17) or Main rotor servo-control SC8031 (18)(Figure 1). Refer to Work Card Assembly by screws and nuts - Joining [MTC 20-02-05-404](#).

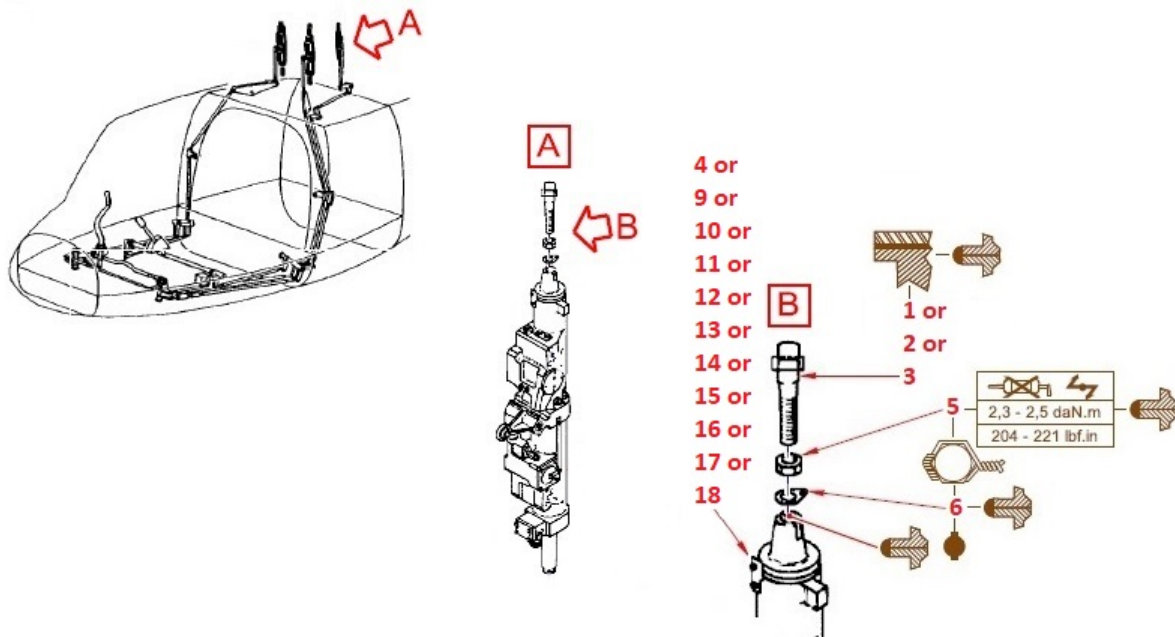

Figure 1

- 4.2.1. If you get to the minimum torque 2.3 daN.m (204 lbf.in) value before the marks align:
- Torque until the marks align but do not torque to more than the max torque value given in figure 1
 - Use Lock-wire CM 776 to safety the nut (5) with the nut retainer (6).
 - Apply a bead of Sealing compound CM 6068 to:
 - The upper end of the Main rotor servo-control SC8034-2 (4) or Main rotor servo-control SC8034-1 (9) or Main rotor servo-control SC8033-2 (10) or Main rotor servo-control SC8033-1 (11) or Main rotor servo-control SC8032-2 (12) or Main rotor servo-control SC8032-1 (13) or Main rotor servo-control SC8032 (14) or Main rotor servo-control SC8031A (15) or Main rotor servo-control SC8031-2 (16) or Main rotor servo-control SC8031-1 (17) or Main rotor servo-control SC8031 (18)
 - The nut (5)
 - The nut retainer (6)
 - The Lock-wire CM776.
 - Comply with paragraph 4.5.
- 4.2.2. If the tightening torque value is more than or equal to 2 daN.m (177 lbf.in) and less than 2.3 daN.m (204 lbf.in) when you get to the alignment of the marks (corresponds to a loss of tightening torque less than 15% of the minimum torque value):
- Torque the nut (5) to the nominal values given in Figure 1.
 - Use Lock-wire CM 776 to safety the nut (5) with the nut retainer (6).
 - Apply a bead of Sealing compound CM 6068 to:
 - The upper end of the Main rotor servo-control SC8034-2 (4) or Main rotor servo-control SC8034-1 (9) or Main rotor servo-control SC8033-2 (10) or Main rotor servo-control SC8033-1 (11) or Main rotor servo-control SC8032-2 (12) or Main rotor servo-control SC8032-1 (13) or Main rotor servo-control SC8032 (14) or Main rotor servo-control SC8031A (15) or Main rotor servo-control SC8031-2 (16) or Main rotor servo-control SC8031-1 (17) or Main rotor servo-control SC8031 (18)
 - The nut (5)
 - The nut retainer (6)
 - The Lock-wire CM776.
 - Comply with paragraph 4.5.
- 4.2.3. If the tightening torque value is less than 2 daN.m (177 lbf.in) when you get to the alignment of the marks (corresponds to a loss of tightening torque more than 15% of the minimum torque value):
- Comply with paragraph 4.3.
- 4.3. Condition check of the threads of the main rotor servo-control

- 4.3.1. Disconnect the Ball bearing end EMRL8RSP3D (1) or Ball bearing end EMRL8RSP3C (2) or Ball bearing end 6701800800 (3) from the swashplate (not shown). Refer to Work Card Removal / Installation - Main rotor actuators - Main servo-controls [MET 67-30-10-401](#)
- 4.3.2. Remove the Ball bearing end EMRL8RSP3D (1) or Ball bearing end EMRL8RSP3C (2) or Ball bearing end 6701800800 (3) from the Main rotor servo-control SC8034-2 (4) or Main rotor servo-control SC8034-1 (9) or Main rotor servo-control SC8033-2 (10) or Main rotor servo-control SC8033-1 (11) or Main rotor servo-control SC8032-2 (12) or Main rotor servo-control SC8032-1 (13) or Main rotor servo-control SC8032 (14) or Main rotor servo-control SC8031A (15) or Main rotor servo-control SC8031-2 (16) or Main rotor servo-control SC8031-1 (17) or Main rotor servo-control SC8031 (18). Refer to Work Card Removal / Installation - Main rotor actuators - Main servo-controls [MET 67-30-10-401](#)
- 4.3.3. Do a detailed visual inspection of threads of the Ball bearing end EMRL8RSP3D (1) or Ball bearing end EMRL8RSP3C (2) or Ball bearing end 6701800800 (3) (Figure 2).
- 4.3.3.1. If there is no dirt, no corrosion and no damaged threads (Figure 2, Detail B):
- Clean the Ball bearing end EMRL8RSP3D (1) or Ball bearing end EMRL8RSP3C (2) or Ball bearing end 6701800800 (3) with Cleaning agent CM 208. Refer to Work Card Use of cleaning products on individual parts and on helicopters - Cleaning [MTC 20-04-01-102](#) Cleaning agent
 - Keep the removed Ball bearing end EMRL8RSP3D (1) or Ball bearing end EMRL8RSP3C (2) or Ball bearing end 6701800800 (3).
- 4.3.3.2. If there is dirt (Figure 2, Detail A), corrosion or damaged threads:
- Do photos of the threads
 - Discard the Ball bearing end EMRL8RSP3D (1) or Ball bearing end EMRL8RSP3C (2) or Ball bearing end 6701800800 (3).

ASB AS365-67-30-0001

Issue 001 2024-04-18
Issue 002 2024-05-15

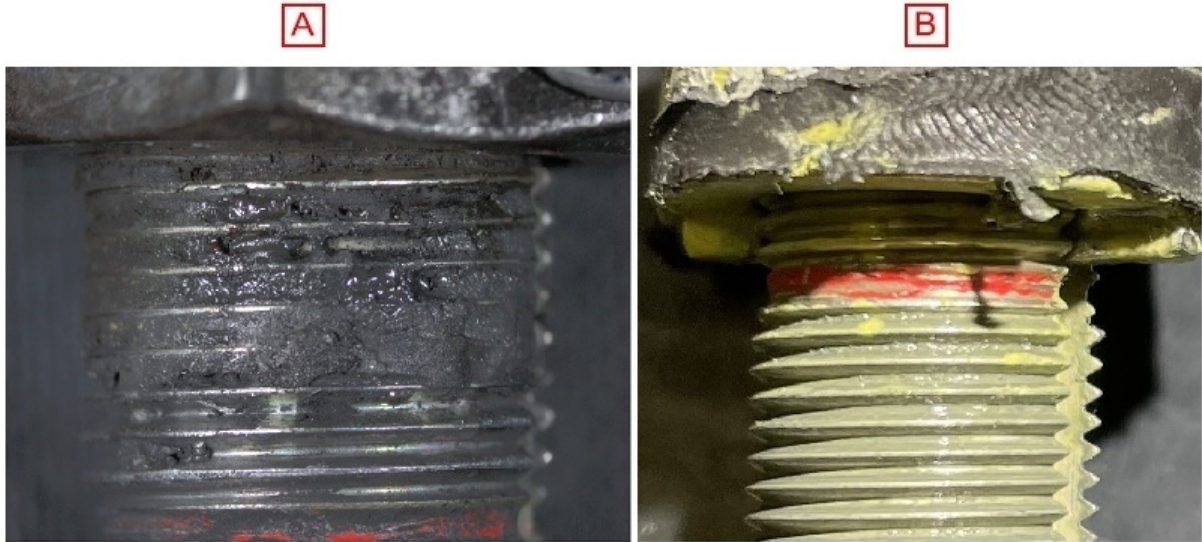

Figure 2

- 4.3.4. Do a detailed visual inspection of the threads on the inner surface of the upper end fitting of the Main rotor servo-control SC8034-2 (4) or Main rotor servo-control SC8034-1 (9) or Main rotor servo-control SC8033-2 (10) or Main rotor servo-control SC8033-1 (11) or Main rotor servo-control SC8032-2 (12) or Main rotor servo-control SC8032-1 (13) or Main rotor servo-control SC8032 (14) or Main rotor servo-control SC8031A (15) or Main rotor servo-control SC8031-2 (16) or Main rotor servo-control SC8031-1 (17) or Main rotor servo-control SC8031 (18) with the Flashlight (7) (not shown) and the Articulated mirror (8) (not shown):
- Do photos of the threads
 - Clean the threads on the inner surface of the upper end fitting of the Main rotor servo-control SC8034-2 (4) or Main rotor servo-control SC8034-1 (9) or Main rotor servo-control SC8033-2 (10) or Main rotor servo-control SC8033-1 (11) or Main rotor servo-control SC8032-2 (12) or Main rotor servo-control SC8032-1 (13) or Main rotor servo-control SC8032 (14) or Main rotor servo-control SC8031A (15) or Main rotor servo-control SC8031-2 (16) or Main rotor servo-control SC8031-1 (17) or Main rotor servo-control SC8031 (18) with Cleaning agent CM 208. Refer to Work Card Use of cleaning products on individual parts and on helicopters - Cleaning [MTC 20-04-01-102](#)
 - Do photos of the threads after cleaning.
- 4.3.4.1. If there is oxidation, corrosion or damaged threads (Figure 3, Detail B), comply with paragraph 4.4.
- 4.3.4.2. If there is no oxidation, no corrosion and no damaged threads (Figure 3, Detail A), comply with paragraph 4.3.5.

ASB AS365-67-30-0001

Issue 001 2024-04-18
Issue 002 2024-05-15

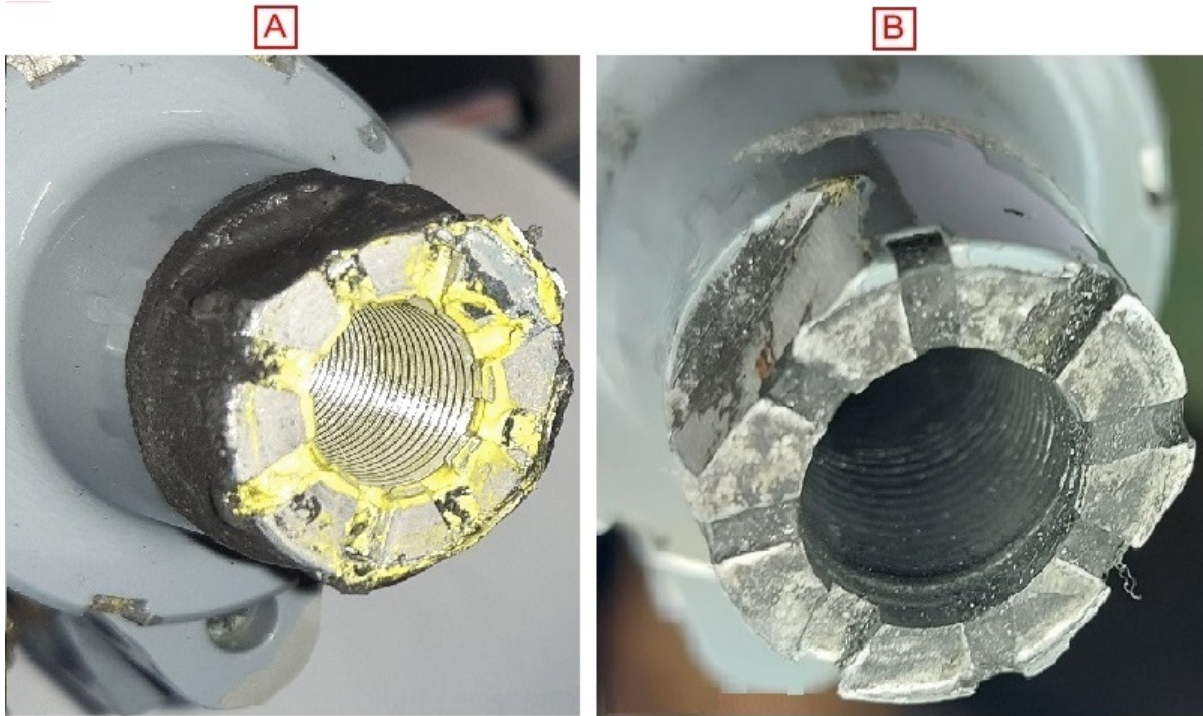

Figure 3

4.3.5. Turn a serviceable (new one or removed one if the threads were clean) Ball bearing end EMRL8RSP3D (1) or Ball bearing end EMRL8RSP3C (2) or Ball bearing end 6701800800 (3) until its threads are almost fully in the upper end fitting of the Main rotor servo-control SC8034-2 (4) or Main rotor servo-control SC8034-1 (9) or Main rotor servo-control SC8033-2 (10) or Main rotor servo-control SC8033-1 (11) or Main rotor servo-control SC8032-2 (12) or Main rotor servo-control SC8032-1 (13) or Main rotor servo-control SC8032 (14) or Main rotor servo-control SC8031A (15) or Main rotor servo-control SC8031-2 (16) or Main rotor servo-control SC8031-1 (17) or Main rotor servo-control SC8031 (18):

- If there is a hard point, comply with paragraph 4.4.
- If there is no hard point, comply with paragraph 4.3.6.

4.3.6. Install a serviceable Ball bearing end EMRL8RSP3D (1) or Ball bearing end EMRL8RSP3C (2) or Ball bearing end 6701800800 (3) on the Main rotor servo-control SC8034-2 (4) or Main rotor servo-control SC8034-1 (9) or Main rotor servo-control SC8033-2 (10) or Main rotor servo-control SC8033-1 (11) or Main rotor servo-control SC8032-2 (12) or Main rotor servo-control SC8032-1 (13) or Main rotor servo-control SC8032 (14) or Main rotor servo-control SC8031A (15) or Main rotor servo-control SC8031-2 (16) or Main rotor servo-control SC8031-1 (17) or Main rotor servo-control SC8031 (18). Refer to Work Card Removal / Installation - Main rotor actuators - Main servo-controls [MET 67-30-10-401](#)

4.3.7. Connect the Ball bearing end EMRL8RSP3D (1) or Ball bearing end EMRL8RSP3C (2) or Ball bearing end 6701800800 (3) to the swashplate (not shown). Refer to Work Card Removal / Installation - Main rotor actuators - Main servo-controls [MET 67-30-10-401](#)

4.3.8. Comply with paragraph 4.5.

4.4. Replacement of the main rotor servo-control

4.4.1. Contact Airbus Helicopters through a Technical Event in the technical request management tool, to which you can get access through the Keycopter portal. Write the text that follows in the topic field of the Technical Event: ALERT SERVICE BULLETIN No. 67-30-0001 and send photos.

4.4.2. Remove the Main rotor servo-control SC8034-2 (4) or Main rotor servo-control SC8034-1 (9) or Main rotor servo-control SC8033-2 (10) or Main rotor servo-control SC8033-1 (11) or Main rotor servo-control SC8032-2 (12) or Main rotor servo-control SC8032-1 (13) or Main rotor servo-control SC8032 (14) or Main rotor servo-control SC8031A (15) or Main rotor servo-control SC8031-2 (16) or Main rotor servo-control SC8031-1 (17) or Main rotor servo-control SC8031 (18).

Refer to Work Card Removal / Installation - Main rotor actuators - Main servo-controls [MET 67-30-10-401](#)

4.4.3. Install a serviceable Main rotor servo-control SC8034-2 (4) or Main rotor servo-control SC8034-1 (9) or Main rotor servo-control SC8033-2 (10) or Main rotor servo-control SC8033-1 (11) or Main rotor servo-control SC8032-2 (12) or Main rotor servo-control SC8032-1 (13) or Main rotor servo-control SC8032 (14) or Main rotor servo-control SC8031A (15) or Main rotor servo-control SC8031-2 (16) or Main rotor servo-control SC8031-1 (17) or Main rotor servo-control SC8031 (18). Refer to Work Card Removal / Installation - Main rotor actuators - Main servo-controls [MET 67-30-10-401](#)

4.4.4. Comply with paragraph 4.5.

4.5. Complete the Response form in digital version or in paper version no later than one week after you comply with this ALERT SERVICE BULLETIN.

4.5.1. To complete the digital version of the Response form:

- Flash the QR code or follow the hypertext link in sub-paragraph 5.5. of paragraph 5. CLOSE UP.
- Fill the Response form online.
- If a tightening torque value less than 2 daN.m (177 lbf.in) was detected:
 - Create a Technical Event in WebTEK to customersupport.helicopters@airbus.com
 - In the Technical Event, please write the key words: "ASB 67-30-0001" and "Torque value less than 2 daN.m (177 lbf.in)"
 - Send a copy of the Response form and the photos.

NOTE

More details about Airbus Helicopters Technical Support organization and how to raise Technical Event are available in IN 3041-I-00.

Or,

4.5.2. To complete the paper version of the Response form:

- Print the Response form (Figure 4 and Figure 5).
- Fill the Response form.
- Send the Response form to: customersupport.helicopters@airbus.com. In the email title, please write: "ASB 67-30-0001 - Check of the connection between the upper ball bearing end and the main rotor servo-control" - Retex.

ASB AS365-67-30-0001

Issue 001	2024-04-18
Issue 002	2024-05-15

NOTE

More details about Airbus Helicopters Technical Support organization and how to raise Technical Event are available in IN 3041-I-00.

AIRBUS
Airbus Helicopters

SB ID Card Questionnaire
Questionnaire for AS365-67-30-0001

Page 1 of 2

SB ID Card

Title
Servo-control system - Check of the connection between the upper ball bearing end and the main rotor servo-control

Description
The purpose of this ALERT SERVICE BULLETIN is to check the nut tightening torque of the upper ball bearing end of the main rotor servo-controls.
Reason for issue 002
The purpose of issue 002 of this ALERT SERVICE BULLETIN is to update the Response form and add a reporting request to Airbus Helicopters technical support if a tightening torque value less than 2 daN.m (177 lbf.in) has been detected during the check of the nut tightening torque.
Issue 002 of this ALERT SERVICE BULLETIN has no effect on the compliance with issue 001 of this ALERT SERVICE BULLETIN.

Compliance information

Applied on:
On aircraft

AC S/N: _____ **TTSN:** _____

Questionnaire

Did you find a loss of tightening torque? *

No
 Yes, the tightening torque was between 2 and 2.3 daN.m
 Yes, the tightening torque was less than 2 daN.m

Could you please upload the photos taken during compliance with this ALERT SERVICE BULLETIN?

.....
.....
.....

Which main rotor servo-control(s) had a loss of tightening torque?

Left rear servo-control
 Left front servo-control
 Right front servo-control

What was the torque value (daN.m or lbf.in) of the main rotor servo-control(s) that had a loss of tightening torque?

.....
.....
.....

Figure 4



SB ID Card Questionnaire

Page 2 of 2

Questionnaire for AS365-67-30-0001

If you found a loss of tightening torque, did you replace the main rotor servo-control(s)?

Yes No

Identify the reference(s) of the main rotor servo-control(s) that had a loss of tightening torque:

- SC8031
- SC8031-1
- SC8031-2
- SC8031A
- SC8032
- SC8032-1
- SC8032-2
- SC8033-1
- SC8033-2
- SC8034-1
- SC8034-2

How many flight hours (FH) were recorded on the main rotor servo-control(s) that had a loss of tightening torque since last installation on the helicopter?

.....
.....

Upload a copy of the log card (FM) of the main rotor servo-control(s) that had a loss of tightening torque.

.....
.....

Figure 5

ASB AS365-67-30-0001

Issue 001 2024-04-18
Issue 002 2024-05-15

5. CLOSE UP

- 5.1. Remove all tools, the materials and the equipment from your work area.
- 5.2. Install the MGB cowlings. Refer to Work Card MET 53-50-00-401 MGB cowlings: Removal / Installation - Cowlings and fairings.
- 5.3. Remove the access equipment.
- 5.4. Connect all the electrical power supplies.
- 5.5. Record the full compliance with this ALERT SERVICE BULLETIN in the helicopter documents and in the log card of the main rotor servo-control. Refer to Drafting and updating the log card (FM) - General rules applicable to aircraft MTC 20-08-05-101.
- 5.6. Record compliance with this ALERT SERVICE BULLETIN (see IN 3785-I-00 for instructions): QR code or hypertext link.



[ASB AS365-67-30-0001](#)

End of service bulletin