

# GSE & TOOL MANUAL

<b>TITLE</b>	<b>P/N 3G5260G00131 FOOTSTEP CUT KIT</b>
--------------	--

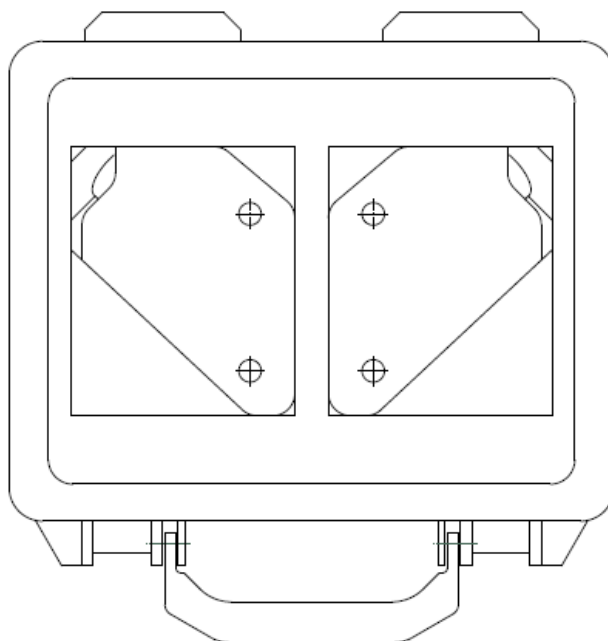



**GSE & TOOL  
USE AND MAINTENANCE MANUAL**

Manual number:  
**MAN-3G5260G00131  
REV.A**

Pag. 2 of 16

**REVISION HISTORY**

<b>REV</b>	<b>CHANGE DESCRIPTION</b>	<b>DATE</b>
A	First issue	07/06/2024

## SUMMARY

SUMMARY .....	3
LIST OF TABLE .....	4
LIST OF FIGURE .....	4
1. SCOPE .....	5
1.1. APPLICABILITY .....	5
1.2. OBJECT .....	5
1.3. WARNING and SAFETY INSTRUCTIONS.....	5
2. DOCUMENTS .....	6
2.1. APPLICABLE DOCUMENTS .....	6
2.2. ACRONYMS USED .....	6
3. DESCRIPTION .....	7
4. TOP ASSEMBLY DRAWINGS.....	7
5. IDENTIFICATION .....	7
6. OVERALL DIMENSIONS .....	8
7. WEIGHT .....	8
8. MAIN PARTS .....	9
9. MAIN FEATURES DESCRIPTION .....	9
10. WARNING AND SAFETY NOTES.....	10
10.1. WARNING NOTE .....	10
10.2. SAFETY NOTES.....	11
11. STORAGE .....	12
11.1. LUBRICATION BEFORE STORAGE .....	12
11.2. STORAGE CONFIGURATION .....	12
12. MAINTENANCE .....	12
12.1. CLEANING .....	12
12.1.1. SPECIAL TOOLS, FIXTURE AND EQUIPMENT .....	12
12.1.2. PART REQUIREMENTS .....	12
12.1.3. MANUAL CLEANING.....	12
12.2. CHECKS .....	13
12.2.1. SPECIAL TOOLS, FIXTURE AND EQUIPMENT .....	13
12.2.2. VISUAL EXAMINATION .....	13
12.2.3. PERIODICAL CHECKS .....	14
12.2.4. DIMENSIONAL CHECKS .....	14
12.2.5. SPECIAL CHECKS SUMMARY .....	14
13. CALIBRATION .....	14
14. SHELF LIFE .....	14

	<b>GSE &amp; TOOL USE AND MAINTENANCE MANUAL</b>	Manual number: <b>MAN-3G5260G00131</b> <b>REV.A</b>
		Pag. 4 of 16

15.	SPARE PARTS .....	15
15.1.	REPLACEMENT INSTRUCTIONS .....	15
16.	CE MARKING.....	15
17.	HAZARDOUS AND POTENTIALLY HAZARDOUS MATERIALS .....	15
	ANNEX A.....	16

**LIST OF TABLE**

Table 1 – Warning Instruction .....	5
Table 2 – Applicable Documents.....	6
Table 3 – Warning Note.....	10
Table 4 – Visual Check.....	14
Table 5 – Spare Parts.....	15

**LIST OF FIGURE**

<i>Figure 1 – Tool kit, mast vibration absorber rem/ins .....</i>	<i>7</i>
<i>Figure 2 – LHD Identification tag with P/N .....</i>	<i>7</i>
Figure 3 – Main Parts .....	9
<i>Figure 4 – Safety Notes.....</i>	<i>11</i>
Figure 5 – Spare Parts .....	15

## 1. SCOPE

### 1.1. APPLICABILITY



The contents of this document are meant to provide information on the P/N 3G5260G00131 FOOTSTEP CUT KIT.

### 1.2. OBJECT

The object of this document is to describe the AGE and its components, its main features and it will also provide all needed maintenance requirements to keep in service the P/N 3G5260G00131 FOOTSTEP CUT KIT.

### 1.3. WARNING AND SAFETY INSTRUCTIONS

A number of symbols are used throughout this document to indicate information to which the user should pay attention to. These are indicated below along with the specific meaning.

 <b>Warning</b>	Indicates a potentially dangerous situation which might result in severe injuries or even death, if no precautions are taken.
 <b>Caution</b>	Indicates a potentially dangerous situation which might result damage to the equipment.
 <b>Notice</b>	Indicates an information that gives an advice to the operator.

*Table 1 – Warning Instruction*

	<b>GSE &amp; TOOL USE AND MAINTENANCE MANUAL</b>	Manual number: <b>MAN-3G5260G00131</b> <b>REV.A</b>
		Pag. 6 of 16

## 2. DOCUMENTS

### 2.1. APPLICABLE DOCUMENTS

The following table lists the applicable documents

REF	REFERENCE OF DOCUMENT	TITLE
1	SB 139-788	ATA 52 - SAR PROTECTION FOOTSTEP CRACK INSPECION

*Table 2 – Applicable Documents*

### 2.2. ACRONYMS USED

The main acronyms used in this document are listed below:

LHD	Leonardo Helicopter Division
HC	Helicopter
P/N	Part Number
S/N	Serial Number
N.A.	Not Applicable

### 3. DESCRIPTION

The tool is used to identify the correct cutting position during the repair phase of cracked footstep through retromod.

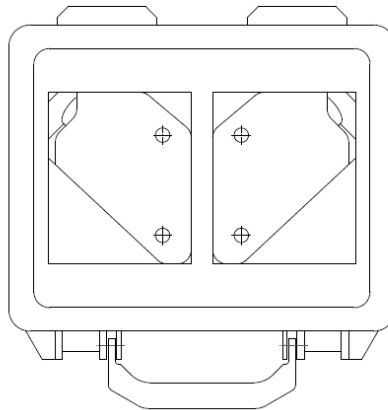

*Figure 1 – FOOTSTEP CUT KIT*

### 4. TOP ASSEMBLY DRAWINGS

Refer to P/N 3G5260G00131 FOOTSTEP CUT KIT.

### 5. IDENTIFICATION

The tool identification P/N is marked on the LHD identification tag located on top of the case.

		<b>LEONARDO</b>	
P/N	3G5260G00131		
MFG. DATE		ISS.	
C. I.		GRWT kg	

*Figure 2 – LHD Identification tag with P/N 3G5260G00131*



## GSE & TOOL USE AND MAINTENANCE MANUAL

Manual number:  
**MAN-3G5260G00131**  
**REV.A**

Pag. 8 of 16

### **6. OVERALL DIMENSIONS**

- Length: 271 mm
- Width: 181 mm
- Height: 105 mm

### **7. WEIGHT**

- Total Weight: 1,64 kg



## 8. MAIN PARTS

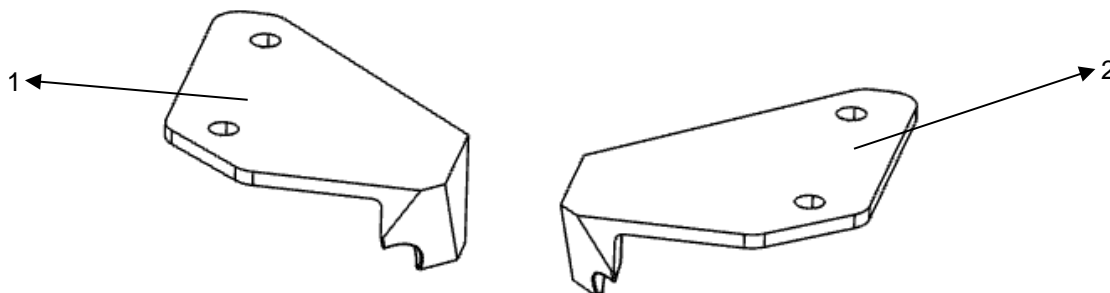

Figure 3 – Main Parts

The main parts of the P/N 3G5260G00131 FOOTSTEP CUT KIT are:

1. 3G5260G00651 MACHINED JIG RH FOR CUT FOOTSTEP
2. 3G5260G00551 MACHINED JIG LH FOR CUT FOOTSTEP

## 9. MAIN FEATURES DESCRIPTION

The kit, supplied in a case, is composed of:

- MACHINED JIG RH FOR CUT FOOTSTEP

The tool is used to identify the correct position of the cut of the right footstep, without making the cut, in order to subsequently install the retromod.

- MACHINED JIG LH FOR CUT FOOTSTEP

- The tool is used to identify the correct position of the cut of the left footstep, without making the cut, in order to subsequently install the retromod.

## 10. WARNING AND SAFETY NOTES

### 10.1. WARNING NOTE





 <b>Warning</b>	Use this equipment only for the purpose that it is designed for. Any other use can result in injury or serious material damage to the components.
 <b>Caution</b>	The Manual can never integrally replace the adequate competence of the user.
 <b>Warning</b>	Before and after each use of the equipment is necessary to perform the checks required. Do not operate with a tool damaged or partially completed, or partially assembled.
 <b>Caution</b>	This Manual provides guidelines and instructions of the equipment that are in addition to - but are not intended to replace or modify but only to integrate - any general or specific rule, regulation, decree or law that is in force in the place where the equipment is in use.

Table 3 – Warning Note

## 10.2. SAFETY NOTES

Remember to wear protective overalls, safety shoes, protective gloves and glasses during all operational and maintenance phases.



Figure 4 – Safety Notes

	<b>GSE &amp; TOOL USE AND MAINTENANCE MANUAL</b>	Manual number: <b>MAN-3G5260G00131 REV.A</b>
		Pag. 12 of 16

## 11. STORAGE

The Tool shall be properly stored to provide protection from external weather conditions, damage and dirty particles.

The Kit shall be stored in the dedicated transportation box (part of the Kit).

Ensure that the tool parts are clean before storage.

### 11.1. LUBRICATION BEFORE STORAGE

N.A.

### 11.2. STORAGE CONFIGURATION

The Tool has no particular storage configuration.

## 12. MAINTENANCE

 <b>Notice</b>	<p>Correct regular maintenance allows preventing most faults and safeguards of tool performance in time, thereby making it last longer.</p>
---	---

### 12.1. CLEANING

Before inspection and after each use, carry out the cleaning of the tool components.

#### 12.1.1. SPECIAL TOOLS, FIXTURE AND EQUIPMENT

No special tools, fixture and equipment are required for cleaning.

#### 12.1.2. PART REQUIREMENTS

The parts to clean should be free from the moisture, emulsified water, soaps and metal shavings that can develop of corrosive acids.

They must also be free from wide grease and / or slosh deposits.

#### 12.1.3. MANUAL CLEANING

- A. Clean thoroughly all metal surfaces with a clean lint-free cloth (Local supply) moistened with Cleaning Solvent (MIL-PRF-680C, Type II) to do general spot cleaning of large groups areas.
- B. Repeat the cleaning process again by means another clean lint-free cloth (Local supply).
- C. Drying.
  - Verify that the solvent should not be trapped in the cavity. Normally, the solvent evaporates at room temperature in a satisfactory manner.



## 12.2. CHECKS

 <b>Caution</b>	<p>Before and after each use or at least every year, carry out the check of kit component.</p>
---	--

 <b>Caution</b>	<p>Before each use ensure that the manual is available to the operator, in the event of loss, request a copy to Leonardo Helicopters Division.</p>
---	--

The Tool kit shall be submitted to following checks to guarantee the functionality.

All required checks shall be registered on CHECK RECORDS Table (Ref. *TLC\_Table 1*)

 <b>Notice</b>	<p>After each use of tool ensure to have registered the number of uses on HISTORICAL USES RECORD Table (Ref. <i>TLC_Table 2</i>).</p>
<p>*</p>  <b>Notice</b>	<p>The Tool Log Card template contained in the Annex A of this manual can be replaced with any other log card template in use in the plant where the equipment is in use.</p>

### 12.2.1. SPECIAL TOOLS, FIXTURE AND EQUIPMENT

No special tools, fixture and equipment are required for the checks.



### 12.2.2. VISUAL EXAMINATION

All required visual checks are listed on Table 4

PERIODICITY	CHECK TYPE		COMPONENTS
BEFORE AND AFTER EVERY USE	VISUAL EXAMINATI ON	Evidence of impact	All
		Crushing or stripping	All
		Cracks	All
		Dents	All

PERIODICITY	CHECK TYPE	COMPONENTS
	Wear	All
	Distortions	All
	Corrosion	All
	Loose or defective attaching parts (warning flag)	All
	Unsticking of parts	Identification plate.
	Damage to the threads	All
	Marking	All
	Damage to the pins and to the shell	N.A.
	Damage to the insulation sleeves and wires	N.A.

Table 4 – Visual Check

 <b>Caution</b>	Replace the parts that do not obey the inspection requirements.
 <b>Notice</b>	Restore the marking of the parts that results damaged or not readable.

### 12.2.3. PERIODICAL CHECKS

N.A.

### 12.2.4. DIMENSIONAL CHECKS

N.A.

### 12.2.5. SPECIAL CHECKS SUMMARY

N.A.

## 13. CALIBRATION

No Calibration is required.

## 14. SHELF LIFE

N.A.

## 15. SPARE PARTS

Any request of spare parts must indicate the reference number of the spares, the Part Number kit the Serial Number and Manufacturer Code of the assy for which the spare is requested.

Only standard fittings may be replaced with others with same dimensions, material, treatment surface and equal or higher strength.

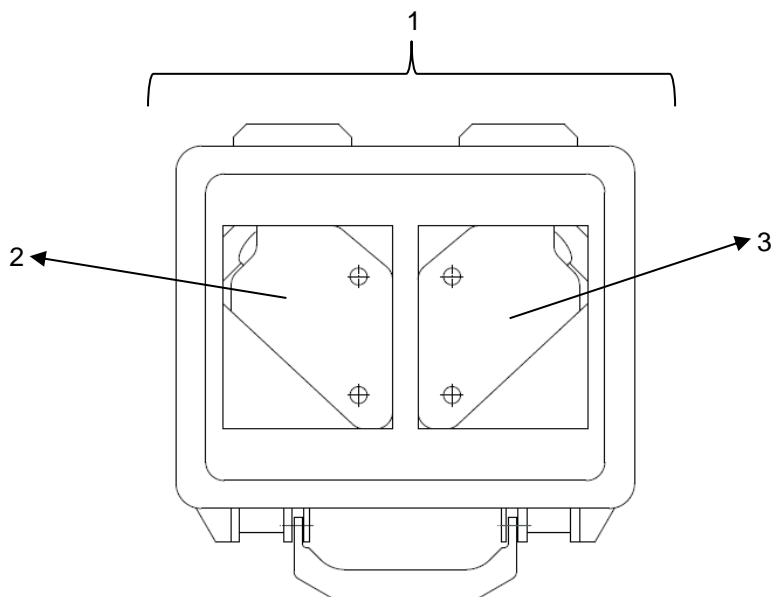

*Figure 5 – Spare Parts*

ITEM	P/N	DESCRIPTION	Q.TY	NOTE
1	3G5260G00131	FOOTSTEP CUT KIT	REF	
2	3G5260G00551	MACHINED JIG LH FOR CUT FOOTSTEP	1	
3	3G5260G00651	MACHINED JIG RH FOR CUT FOOTSTEP	1	

*Table 5 – Spare Parts*

### 15.1. REPLACEMENT INSTRUCTIONS

The replacement of parts of the kit does not require specific instructions.

## 16. CE MARKING

No CE marking is required for the P/N 3G5260G00131 FOOTSTEP CUT KIT.

## 17. HAZARDOUS AND POTENTIALLY HAZARDOUS MATERIALS

N.A.



**GSE & TOOL  
USE AND MAINTENANCE MANUAL**

Manual number:  
**MAN-3G5260G00131  
REV.A**

Pag. 16 of 16

# **ANNEX A**

# **TOOL LOG CARD**





# TOOL LOG CARD

ISSUE -/-  
Pag. 1 of 3

<b>TOOL KIT P/N:</b> [1]	<b>TOOL KIT DESCRIPTION:</b> [2]	<b>TOOL KIT S/N:</b> [3]
<b>TOOL P/N:</b> [4]	<b>TOOL S/N:</b> [5]	<b>REMARKS:</b> [6]

## Section 1: CHECKS RECORD

[7] N° check	[8] DATE	[9] P/N TO CHECK	[10] CHECK	[11] FREQUENCY	[12] RESULT	[13] NOTE	CERTIFICATION [14]
							STAMP & SIGNATURE [15]
1							
2							
3							
4							
5							
6							
7							
8							
9							
10							
<b>FINAL ACCEPTANCE [16]</b>							
<b>STAMP &amp; SIGNATURE [17]</b>						<b>DATE [18]</b>	

TLC\_Table 1



# TOOL LOG CARD

ISSUE -/  
Pag. 2 of 3

<b>TOOL KIT P/N:</b> [1]	<b>TOOL KIT DESCRIPTION:</b> [2]	<b>TOOL KIT S/N:</b> [3]
<b>TOOL P/N:</b> [4]	<b>TOOL S/N:</b> [5]	<b>REMARKS:</b> [6]

## Section 2: HISTORICAL USES RECORD

[19] N°USE	[8] DATE	[6] NOTE	[13] CERTIFICATION	[19] N°USE	[8] DATE	[6] NOTE	[13] CERTIFICATION
			[14] STAMP & SIGNATURE				[14] STAMP & SIGNATURE
1				11			
2				12			
3				13			
4				14			
5				15			
6				16			
7				17			
8				18			
9				19			
10				20			

TLC\_Table 2

## LOG CARD FILLING INSTRUCTIONS

<b>FIELD #</b>	<b>HEADER</b>	<b>NOTE</b>
<b>1</b>	Part number of the tool Kit	
<b>2</b>	Tool Kit denomination	
<b>3</b>	Serial Number of the tool Kit	
<b>4</b>	Part Number of the tool (part of kit)	
<b>5</b>	Serial Number of the tool (if applicable)	
<b>6</b>	Indicate any details of the use	
<b>7</b>	Sequential number of check performed	
<b>8</b>	Date of the activity	
<b>9</b>	PN of tool or component (part of tool) checked/affected by issue	
<b>10</b>	Typology or description of checks /issue	
<b>11</b>	Check frequency	
<b>12</b>	Check result	
<b>13</b>	Check remarks	
<b>14</b>	Performance certification	
<b>15</b>	Stamp and signature of the personnel which performs the check	
<b>16</b>	Section related to the final approval	
<b>17</b>	Stamp and signature of the personnel which performs the final approval	
<b>18</b>	Date on which the final check was made	
<b>19</b>	Sequential number of performed used of the tool	