

 CT7-2E1 ALERT SERVICE BULLETIN - 72- A0034 R00

Revised: 02  
/26/2024

SB 72-A0034 R00 ENGINE - POWER TURBINE MODULE (72-50-00) - POWER TURBINE SHAFT  
/TORQUE REFERENCE TUBE MAGNETIC INSERT BRAZE INSPECTION

Issued: 02  
/26/2024

**GE Designated: -CONFIDENTIAL-**

The information contained in this document is GE proprietary information and is disclosed in confidence. It is the property of GE and shall not be used, disclosed to others or reproduced without the express written consent of GE, including, but without limitation, it is not to be used in the creation, manufacture, development, or derivation of any repairs, modifications, spare parts, designs, or configuration changes or to obtain FAA or any other government or regulatory approval to do so. If consent is given for reproduction in whole or in part, this notice and the notice set forth on each page of this document shall appear in any such reproduction in whole or part.

This technical data is considered subject to the Export Administration Regulations (EAR) pursuant to 15 CFR Parts 730-774. Transfer of this data by any means to a Non-U.S. Person, whether in the United States or abroad, without the proper U.S. Government authorization (e.g., License, exemption, NLR, etc.), is strictly prohibited.

Copyright (2024) General Electric Company, U.S.A.

1. PLANNING INFORMATION

A. Effectivity

\* \* \* CT7-2E1

This Alert Service Bulletin is applicable to CT7-2E1 engine models with power turbine (PT) drive shaft assembly part number (P/N) [5125T92G01](#) installed with less than 100 hours-time since new (TSN) or 100 hours-time since replacement (TSR) of the PT drive shaft assembly produced or made between 2020 and 2023.

The affected engine serial numbers (ESN) and PT drive shaft assembly serial numbers (S/N) listed in this Alert Service Bulletin is the best available data.

See Appendix A, Table 1 for a list of applicable ESNs and PT drive shaft assembly S/Ns.

B. Description

This Alert Service Bulletin provides instructions to remove the engine C-sump cover and use an Ultrasonic Test (UT) Phase Array probe to inspect the PT drive shaft assembly reference tube magnetic insert end braze joint.

C. Compliance

Category 1

GE recommends that you do this Alert Service Bulletin before subsequent flight.

Non-passenger operation is allowed for repositioning the aircraft to a maintenance facility if required.

Impact A

This recommendation is to address a condition that may affect flight safety.

NOTE: This Alert Service Bulletin can be done on wing or in shop.

D. Concurrent Requirements

None.

E. Reason

(1) Objective:

This Alert Service Bulletin provides an inspection to verify the minimum acceptable braze coverage on the PT drive shaft assembly reference tube magnetic insert.

(2) Condition:

Multiple PT drive shaft assemblies were shipped with inadequate braze coverage on the end of the PT shaft reference tube magnetic insert joint.

(3) Cause:

Inadequate braze coverage within the torque reference tube magnetic insert joint can become compromised leading to improper torque and speed indications.

(4) Improvement:

Planning has been updated and UT Phase Array probe inspection has been incorporated into the manufacturing process of the torque reference tube assembly.

(5) Substantiation:

Substantiation is by analysis and field experience.

F. Approval

The data contained in this Alert Service Bulletin has been reviewed by the FAA or authorized entity representing the FAA and the repair(s) and modification(s) herein comply with the applicable Aviation Regulations and are APPROVED for installation in the model(s) listed in this Alert Service Bulletin.

G. Manpower

You will need approximately one man-hour to do this Alert Service Bulletin once the area is exposed.

H. Weight and Balance

Weight and balance are not changed.

I. References (Use the latest version of these documents)

- CT7-2E1 Turboshaft Engine Service Record
- FST-2572, Phase Array Ultrasonic Inspection Procedure
- GEK 112043-02, CT7-2E Maintenance Manual (MM)
- GEK 112044-02, CT7-2E Shop Manual (SM)
- GEK 115715, CT7-E1 Illustrated Parts Catalog (IPC)

J. Publications Affected

None.

K. Interchangeability

Not applicable.

L. Software Accomplishment Summary

Not applicable.

2. MATERIAL INFORMATION

A. Material - Price and Availability

(1) Parts necessary to do this Alert Service Bulletin:

Part Number	Qty/ Eng	Part Name	Unit (\$) Price	Pkg Qty	Lead Time Days
<a href="#">4074T58P04</a> <a href="#">01-060A,72-50-00</a>	(1)	Packing, Preformed (SIN 91652)	Quote	(-)	Quote
<a href="#">J1400P011</a> <a href="#">01-060B,72-50-00</a>	(Alt)	Packing, Preformed (SIN 91652)	Quote	(-)	Quote
<a href="#">4074T58P09</a> <a href="#">01-070A,72-50-00</a>	(1)	Packing, Preformed (SIN 91650)	Quote	(-)	Quote
<a href="#">J1400P159</a> <a href="#">01-070B,72-50-00</a>	(Alt)	Packing, Preformed SIN 91650	Quote	(-)	Quote

(2) Other Spare Parts:

None.

(3) Consumables:

Code Number	Description
C02-007	Assembly Fluid, Ultrachem No. 1
--	Oil, Engine

B. Industry Support Information

Not applicable.

C. Configuration Chart

Not applicable.

D. Parts Disposition

See paragraph 3., [ACCOMPLISHMENT INSTRUCTIONS](#).

E. Tooling - Price and Availability

Part Number	Nomenclature
GE-FQAP-803	Ultrasonic Probe Test Kit (Provided by GE Aerospace)

3. ACCOMPLISHMENT INSTRUCTIONS

A. General

NOTE: This task can be performed on-wing with the exhaust center body frame and C-sump housing removed.

NOTE: To accomplish this inspection there must be access to the engine C-sump heat shield to allow removal of the heat shield and the C-sump cover to insert the Phase Array Probe (approximately 12.5 inches (318 mm)). The inspection also requires power for an ultrasonic instrument (approximately 12 inches x 12 inches x 6 inches (305 mm x 305 mm x 152 mm)) which must be visually observed by the inspector during the test and must be in close proximity to the probe. This may require removal of the engine from the aircraft in some installations. This inspection may also be carried out on an engine stand or in an engine storage container with the lid removed.

NOTE: Review the engine log book for the installation time of the installed PT drive shaft assembly P/N [5125T92G01](#). If the current operational time on the part since installation is over 100 hours, compliance with this Alert Service Bulletin is satisfied. Go to paragraph 3.B.(3) and record compliance with this Alert Service Bulletin. If the PT drive shaft assembly is less than 100 hours, proceed with the remainder of this Alert Service Bulletin.

NOTE: This procedure gives instructions to remove the C-sump heat shield (01-020, [Figure 1](#)) and C-sump cover (01-040) to inspect the magnetic insert braze joint on the PT drive shaft assembly (01-070, [Figure 2](#) and [Figure 3](#)).

- (1) Remove the C-sump heat shield (01-020, [Figure 1](#)) and C-sump cover (01-040). Refer to CT7-2E MM GEK 112043-02, 72-50-00, REMOVAL AND INSTALLATION, TASK 72-50-00-400-801, paragraph 4.A..

NOTE: The UT Phase Array Probe inspection must be performed by a level 2 or 3 NDT ultrasonic inspector who has been trained by GE Aerospace.

- (2) Following the GE proprietary inspection procedure FST-2572 - Phase Array Ultrasonic Inspection Procedure for the torque reference tube, perform the braze inspection to quantify the percentage of braze.
  - (a) If the percentage of braze is greater than or equal to 42%, the engine may be returned to service.
  - (b) If the percentage of braze is less than 42%, tag the engine as failed PT shaft UT inspection and return the engine or PT module to an MRO shop for repair or replacement of the PT drive shaft assembly.
- (3) Once the inspection is completed, re-install the C-sump cover (01-040, [Figure 1](#)) and C-sump heat shield (01-020). Refer to CT7-2E MM GEK 112043-02, 72-50-00, REMOVAL AND INSTALLATION, TASK 72-50-00-400-801, paragraph 4.B.(3)
- (4) For installed engines that have passed inspection, perform required checks. Refer to CT7-2E MM GEK 112043-02, 72-00-00, TEST, TASK 72-00-00-760-803, paragraph 4 (Checkout Procedure After Replacement of Parts), paragraph 6.D. (Idle Speed Leakage Check), and paragraph 7.B. (Oil Consumption Check).
- (5) For spare engines at the operator that have passed inspection, perform the following:
  - (a) Go to paragraph [3.B., Compliance](#) as the inspection will meet the intent of this Alert Service Bulletin. When the engine is installed in an aircraft, perform the required checks. Refer to CT7-2E MM GEK 112043-02, 72-00-00, TEST, TASK 72-00-00-760-803, paragraph 6.C. (Functional Test Procedures for Newly Installed Engines and Component Replacement (includes Idle Speed Leakage Check)) and paragraph 7.B. (Oil Consumption Check).
- (6) For engines and modules at an MRO facility that have passed inspection, perform the following:
  - (a) Test engines per CT7-2E SM GEK 112044-02, 72-00-00, TESTING 006, TASK 72-00-00-760-809 (Idle Speed Check) and 72-00-00, TESTING 011, TASK 72-00-00-760-814 (Oil Consumption Check).
  - (b) Test modules per CT7-2E SM GEK 112044-02, 72-00-00, TESTING 004, TASK 72-00-00-760-834 (EngineTest Requirements) (Engine Start, Idle Speed Leakage, Transient, and Engine Shutdown Checks).

B. Compliance

- (1) Record information in Table A.
- (2) Provide copies of Table A and the GE UT inspection report to the GE Field Service Representative and the Customer Representative.
- (3) Record compliance of this Alert Service Bulletin in the appropriate CT7 Turboshaft Engine Service Record.

TABLE A - POWER TURBINE DRIVE SHAFT ASSEMBLY INSPECTION RESULTS

				PT Shaft Time Since		

Engine or PT Module S/N (if applicable)	PT Drive Shaft Assembly P/N	PT Drive Shaft Assembly S/N	PT Shaft Time Since New (Hours)	Repair (Hours)	% Braze Coverage	Date
Work Performed by (Print Name):			Signature:	Date:		

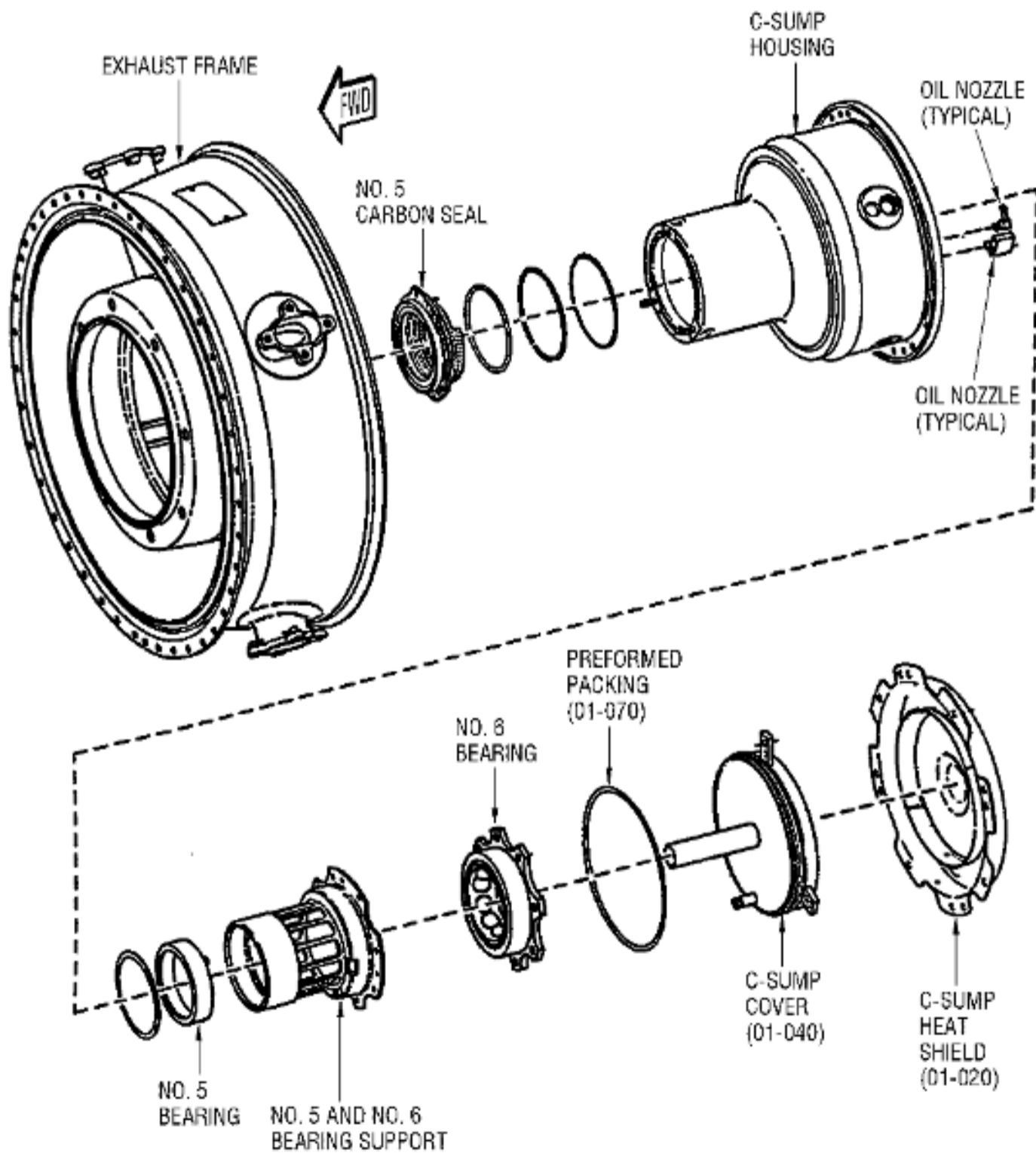

**NOTE:**  
 ALL IPC REFERENCES ARE FROM 72-50-00 UNLESS SPECIFIED DIFFERENTLY.

6045825-00

C-Sump Heat Shield and C-Sump Cover - Removal and Installation  
Figure 1



6045651-00

C-Sump and Aft End of Power Turbine Shaft  
Figure 2

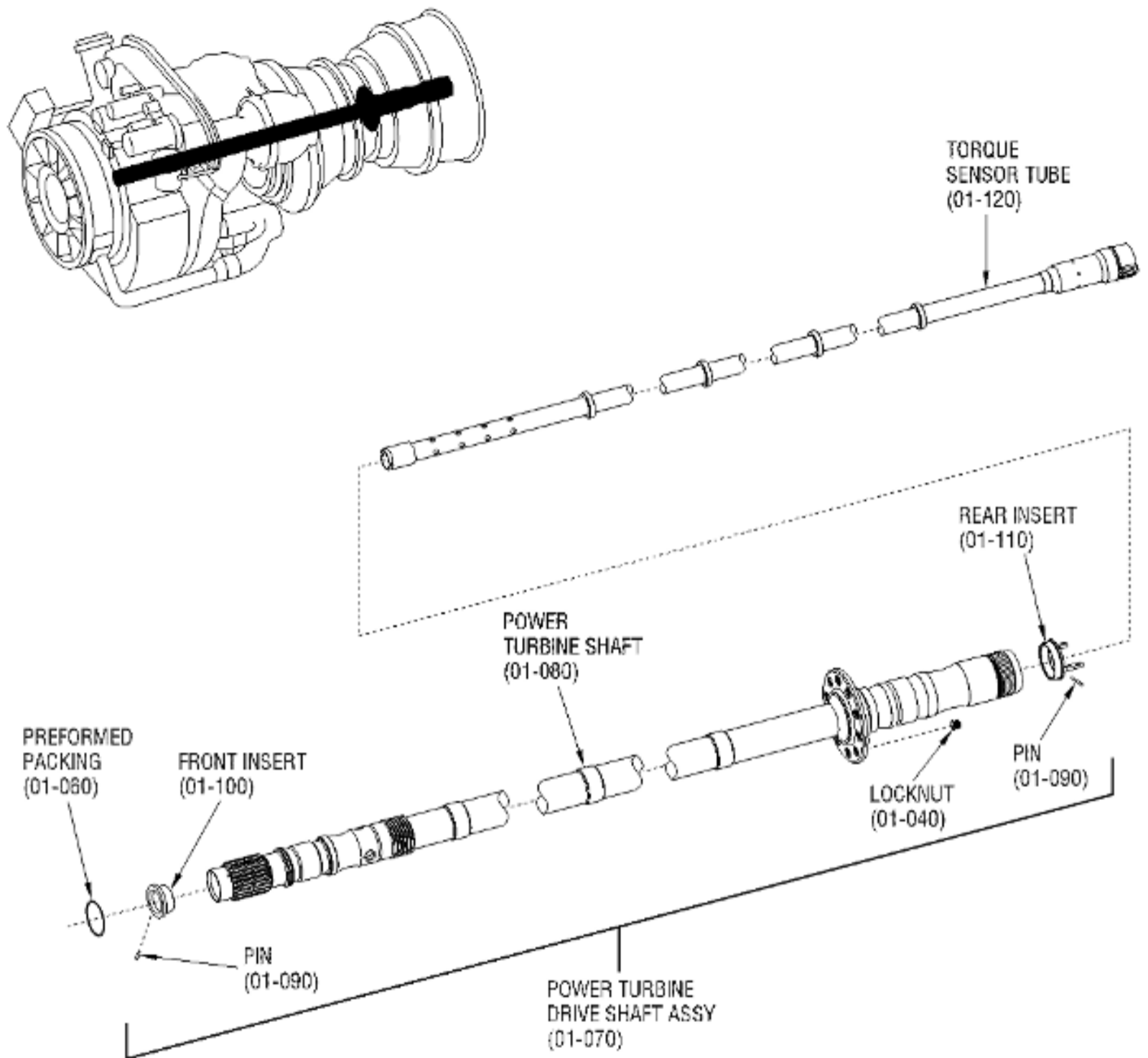

**NOTE:**  
ALL IPC REFERENCES ARE FROM 72-52-00 UNLESS SPECIFIED DIFFERENTLY.

6045824-00

Power Turbine Drive Shaft Assembly  
Figure 3

4. APPENDIX A

TABLE 1 - LIST OF APPLICABLE CT7-2E1 ENGINE AND COMPONENT SERIAL NUMBERS

Component Nomenclature	Part Number	Engine Serial Number	Component Serial Number
Power Turbine Drive Shaft Assy	5125T92G01	780111	UNK
Power Turbine Drive Shaft Assy	5125T92G01	780132	UNK
Power Turbine Drive Shaft Assy	5125T92G01	780298	GATJA6W8
Power Turbine Drive Shaft Assy	5125T92G01	780307	GATJA0R4
Power Turbine Drive Shaft Assy	5125T92G01	780309	GATJA9LL
Power Turbine Drive Shaft Assy	5125T92G01	780310	GATJADNN

## SB 72-A0034 R00 ENGINE - Power Turbine Module (72-50-00) - Power Turbine Shaft/Torque Reference Tube Magnetic Insert Braze Inspection

Power Turbine Drive Shaft Assy	5125T92G01	780311	GATJAE32
Power Turbine Drive Shaft Assy	5125T92G01	780312	GATJAF9W
Power Turbine Drive Shaft Assy	5125T92G01	780326	GATJAN5F
Power Turbine Drive Shaft Assy	5125T92G01	780338	GATJA9LH
Power Turbine Drive Shaft Assy	5125T92G01	780339	GATJC0M1
Power Turbine Drive Shaft Assy	5125T92G01	780342	GATJAPFA
Power Turbine Drive Shaft Assy	5125T92G01	780343	GATJC0T3
Power Turbine Drive Shaft Assy	5125T92G01	780344	GATJC22C
Power Turbine Drive Shaft Assy	5125T92G01	780345	GATJAWRD
Power Turbine Drive Shaft Assy	5125T92G01	780347	GATJC0TA
Power Turbine Drive Shaft Assy	5125T92G01	780349	GATJAT02
Power Turbine Drive Shaft Assy	5125T92G01	780350	GATJC4LW
Power Turbine Drive Shaft Assy	5125T92G01	780351	GATJC52M
Power Turbine Drive Shaft Assy	5125T92G01	780352	GATJC3E3
Power Turbine Drive Shaft Assy	5125T92G01	780353	GATJC5A7
Power Turbine Drive Shaft Assy	5125T92G01	780354	GATJC5W9
Power Turbine Drive Shaft Assy	5125T92G01	780355	GATJC69A
Power Turbine Drive Shaft Assy	5125T92G01	780356	GATJC6JF
Power Turbine Drive Shaft Assy	5125T92G01	780357	GATJC68W
Power Turbine Drive Shaft Assy	5125T92G01	780358	GATJC6FA
Power Turbine Drive Shaft Assy	5125T92G01	780359	GATJC6HM
Power Turbine Drive Shaft Assy	5125T92G01	780361	GATJC89G
Power Turbine Drive Shaft Assy	5125T92G01	780362	GATJC9A6
Power Turbine Drive Shaft Assy	5125T92G01	780363	GATJC9A3
Power Turbine Drive Shaft Assy	5125T92G01	780364	GATJC7WC
Power Turbine Drive Shaft Assy	5125T92G01	780365	GATJC8TP
Power Turbine Drive Shaft Assy	5125T92G01	780366	GATJC90P
Power Turbine Drive Shaft Assy	5125T92G01	780367	GATJCA4E
Power Turbine Drive Shaft Assy	5125T92G01	780368	GATJC3G2
Power Turbine Drive Shaft Assy	5125T92G01	780369	GATJC6JE
Power Turbine Drive Shaft Assy	5125T92G01	780370	GATJC1PP
Power Turbine Drive Shaft Assy	5125T92G01	780371	GATJC6W5
Power Turbine Drive Shaft Assy	5125T92G01	780372	GATJC90M
Power Turbine Drive Shaft Assy	5125T92G01	780373	GATJCALA
Power Turbine Drive Shaft Assy	5125T92G01	780374	GATJCAPR
Power Turbine Drive Shaft Assy	5125T92G01	780375	GATJC6HA
Power Turbine Drive Shaft Assy	5125T92G01	780376	GATJCCG6
Power Turbine Drive Shaft Assy	5125T92G01	780377	GATJCAPK
Power Turbine Drive Shaft Assy	5125T92G01	780378	GATJC90T
Power Turbine Drive Shaft Assy	5125T92G01	780379	GATJCAFK
Power Turbine Drive Shaft Assy	5125T92G01	780380	GATJCC35
Power Turbine Drive Shaft Assy	5125T92G01	780381	GATJCDHW
Power Turbine Drive Shaft Assy	5125T92G01	780382	GATJCEH8
Power Turbine Drive Shaft Assy	5125T92G01	780383	GATJCF59
Power Turbine Drive Shaft Assy	5125T92G01	780384	GATJCEPW
Power Turbine Drive Shaft Assy	5125T92G01	780385	GATJCEHC

**GE Designated: - CONFIDENTIAL Subject to the restrictions on the media**