

 CT7-2E1 ALERT SERVICE BULLETIN - 72- A0028 R02

Revised: 09  
/17/2024

SB 72-A0028 R02 ENGINE - STAGES 1 AND 2 LOW-STRESS GGT ROTOR ASSEMBLY (72-41-00) -  
CT7-2E1 R88 CONTAMINATED HARDWARE REPLACEMENT

Issued: 02  
/01/2023

**GE Designated: -CONFIDENTIAL-**

The information contained in this document is GE proprietary information and is disclosed in confidence. It is the property of GE and shall not be used, disclosed to others or reproduced without the express written consent of GE, including, but without limitation, it is not to be used in the creation, manufacture, development, or derivation of any repairs, modifications, spare parts, designs, or configuration changes or to obtain FAA or any other government or regulatory approval to do so. If consent is given for reproduction in whole or in part, this notice and the notice set forth on each page of this document shall appear in any such reproduction in whole or part.

This technical data is considered subject to the Export Administration Regulations (EAR) pursuant to 15 CFR Parts 730-774. Transfer of this data by any means to a Non-U.S. Person, whether in the United States or abroad, without the proper U.S. Government authorization (e.g., License, exemption, NLR, etc.), is strictly prohibited.

Copyright (2024) General Electric Company, U.S.A.

TRANSMITTAL INFORMATION

REVISION 2 TO ALERT SERVICE BULLETIN 72-A0028

Revision 2 is issued to update the applicable engine serial numbers in paragraph 1.A., Effectivity, and the List of Affected CT7-2E1 Serial Numbers and Components in Table 1.

Revision 1 was issued November 15, 2023. The original was issued February 1, 2023. Revision bars in the left margin identify changes.

1. PLANNING INFORMATION

A. Effectivity

\* \* \* CT7-2E1

This Alert Service Bulletin is applicable to these CT7-2E1 engines:

CT7-2E1 engines, serial numbers 780271, 780272, 780277, 780278, 780280, 780288, 780291, 780297, 780301, 780302, 780313, 780353, 780354, 780356, 780357, 780359, 780360, and spares.

These serial numbers are the best available data.

B. Description

This Alert Service Bulletin provides notification of non-conforming stage 1 turbine disks as listed in [Table 1](#).

C. Compliance

Category 2

GE recommends compliance with this Alert Service Bulletin as follows: for engines listed in [Table 1](#), remove/scrap the stage 1 disk from service at next piece part exposure or before accruing 6,360 cycles whichever comes first.

Impact B

This recommendation is to address a condition that may result in an increased rate of In-Flight Shutdowns (IFSD), Take-off Aborts (TOA), Air Turn Backs (ATB), or Diversions (DIV).

NOTE: This Service Bulletin can be done in shop.

D. Concurrent Requirements

None.

E. Reason

(1) Objective:

To provide notification of non-conforming stage 1 turbine disks.

(2) Condition:

An investigation has revealed a quality escape involving stage 1 turbine disks utilized on the CT7-2E1 engine line. An investigation into the issue has revealed a population of stage 1 turbine disks that have been shipped on production engines, as part of a matched rotor stator assembly. The stage 1 turbine disks non-conformance is an unintended particle contamination introduced at a supplier during the processing of the raw material used to manufacture the disks.

(3) Cause:

The stage 1 turbine disks non-conformance is an unintended particle contamination introduced at a supplier during the processing of the raw material used to manufacture the disks.

(4) Improvement:

Not applicable.

(5) Substantiation:

Substantiation is by analysis.

F. Approval

The data contained in this Alert Service Bulletin has been reviewed by the FAA or authorized entity representing the FAA and the repair(s) and modification(s) herein comply with the applicable Aviation Regulations and are APPROVED for installation in the model(s) listed in this Alert Service Bulletin.

G. Manpower

You will need approximately 16 man-hours to do this Alert Service Bulletin.

H. Weight and Balance

Weight and balance are not changed.

I. References (Use the latest version of these documents)

- CT7 Turboshaft Engine Service Record
- GEK 112043-02, CT7-2E1 Maintenance Manual (MM)
- GEK 112044-02, CT7-2E1 Shop Manual (SM)

J. Publications Affected

CT7 Turboshaft Engine Service Record

K. Interchangeability

If parts are removed, they can be replaced with conforming parts.

L. Software Accomplishment Summary

Not applicable.

2. MATERIAL INFORMATION

A. Material - Price and Availability

(1) Parts necessary to do this Service Bulletin:

Part Number	Qty/ Eng	Part Name	Unit (\$) Price	Pkg Qty	Lead Time Days
<u>Operator Facility:</u>					
<a href="#">5176T38G01</a>	(1)	Matched Assembly, High Pressure Turbine	Quote	(-)	Quote
<u>MRO Facility:</u>					
<a href="#">4185T13P01</a>	(1)	Stage 1 Turbine Disk	Quote	(-)	Quote

NOTE: Prices are provided for planning purposes and are subject to change.

(2) Other Spare Parts:

None.

(3) Consumables:

None.

B. Industry Support Information

Contact your GE Customer Service Manager.

C. Configuration Chart

Not applicable.

D. Parts Disposition

NOTE: GE recommends that you comply with this Alert Service Bulletin at the next piece part exposure for the parts listed in [Table 1](#).

Send all parts removed to:

GE Aviation  
 Attention: Product Support Engineering  
 MZ 37402  
 1000 Western Avenue  
 Lynn, MA 01910

- E. Tooling - Price and Availability  
None.

3. ACCOMPLISHMENT INSTRUCTIONS

A. Operator Facility:

NOTE: GE recommends that you comply with this Alert Service Bulletin at the next piece part exposure or prior to accruing 6,360 cycles, whichever comes, first for the parts listed in [Table 1](#). Removal of the gas generator assembly from the engine for cleaning or access to the combustion liner or stage 1 nozzle does not constitute piece part exposure.

- (1) Remove the gas generator turbine rotor and stator assembly containing the potentially non-conforming stage 1 turbine disks (refer to figure 1). Refer to CT7-2E Maintenance Manual, GEK 112043-02, 72-40-00, REMOVAL AND INSTALLATION, TASK 72-40-00-400-801, applicable paragraphs.
- (2) Install a replacement matched gas generator turbine rotor and stator assembly P/N [5176T38G01](#). Refer to CT7-2E Maintenance Manual, GEK 112043-02, 72-40-00, REMOVAL AND INSTALLATION, TASK 72-40-00-400-801, applicable paragraphs.
- (3) Tag the removed matched gas generator turbine rotor and stator assembly with "Removed non-conforming hardware in compliance with CT7-2E1 Alert Service Bulletin [72-A0028](#)".
- (4) Send the matched gas generator turbine rotor and stator assembly and associated logbook pages to an approved GE MRO Facility.
- (5) Record compliance with CT7-2E1 Alert Service Bulletin [72-A0028](#) in the engine logbook.

B. MRO Facility:

NOTE: GE recommends that you comply with this Alert Service Bulletin at the next piece part exposure or prior to accruing 6,360 cycles, whichever comes first, for the parts listed in [Table 1](#).

- (1) Upon receipt of the matched gas generator turbine rotor and stator assembly, removed in compliance with CT7-2E1 Alert Service Bulletin [72-A0028](#), remove the hardware listed in [Table 1](#). Refer to CT7-2E Shop Manual, GEK 112044-02, 72-41-00, DISASSEMBLY, TASK 72-41-00-030-801.
- (2) Install replacement stage 1 turbine disks. Refer to CT7-2E Shop Manual, GEK 112044-02, 72-41-00, ASSEMBLY, TASK 72-41-00-430-801.
- (3) Send all parts listed in [Table 1](#) to GE Product Support Engineering:

GE Aviation  
 Attention: Product Support Engineering  
 MZ 37402  
 1000 Western Avenue  
 Lynn, MA 01910

C. Service Record Entry

Record compliance with this Alert Service Bulletin in the appropriate CT7 Turboshaft Engine Service Record.

TABLE 1 - LIST OF AFFECTED CT7-2E1 SERIAL NUMBERS AND COMPONENTS

COMPONENT NOMENCLATURE	COMPONENT PART NUMBER	COMPONENT SERIAL NUMBER	ENGINE SERIAL NUMBER
Stage 1 Turbine Disk	4185T13P01	GATJ8AD9	780271
Stage 1 Turbine Disk	4185T13P01	GATJ8AD4	780272
Stage 1 Turbine Disk	4185T13P01	GATJ8CK5	780277
Stage 1 Turbine Disk	4185T13P01	GATJ8AD1	780278
Stage 1 Turbine Disk	4185T13P01	GATJ8AD5	780280
Deleted			
Stage 1 Turbine Disk	4185T13P01	GATJ92KJ	780288
Stage 1 Turbine Disk	4185T13P01	GATJ92KH	780291

SB 72-A0028 R02 ENGINE - Stages 1 and 2 Low-Stress GGT Rotor Assembly (72-41-00) - CT7-2E1 R88 Contaminated Hardware Replacement

Stage 1 Turbine Disk	4185T13P01	GATJ8AD8	780297
Stage 1 Turbine Disk	4185T13P01	GATJ92KE	780301
Stage 1 Turbine Disk	4185T13P01	GATJ8AD6	780302
Stage 1 Turbine Disk	4185T13P01	GATJ92KD	780313
Stage 1 Turbine Disk	4185T13P01	TMT1NEL7	780353
Stage 1 Turbine Disk	4185T13P01	TMT1NEL6	780354
Stage 1 Turbine Disk	4185T13P01	TMT1NEL5	780356
Stage 1 Turbine Disk	4185T13P01	TMT1NEL3	780357
Stage 1 Turbine Disk	4185T13P01	GATJ8CK1	780359
Stage 1 Turbine Disk	4185T13P01	TMT1NEL1	780360
Stage 1 Turbine Disk	4185T13P01	CDAAR57P	Spares
Stage 1 Turbine Disk	4185T13P01	CDAAR57R	Spares
Stage 1 Turbine Disk	4185T13P01	CDARNEUT	Spares
Stage 1 Turbine Disk	4185T13P01	CDARNEUU	Spares
Stage 1 Turbine Disk	4185T13P01	CDARNEUW	Spares
Stage 1 Turbine Disk	4185T13P01	CDARNEW0	Spares
Stage 1 Turbine Disk	4185T13P01	GATJ92KF	Spares
Stage 1 Turbine Disk	4185T13P01	TMT1NEL0	Spares
Stage 1 Turbine Disk	4185T13P01	TMT1NEL2	Spares
Stage 1 Turbine Disk	4185T13P01	TMT1NEL4	Spares

TABLE 2 - DELETED

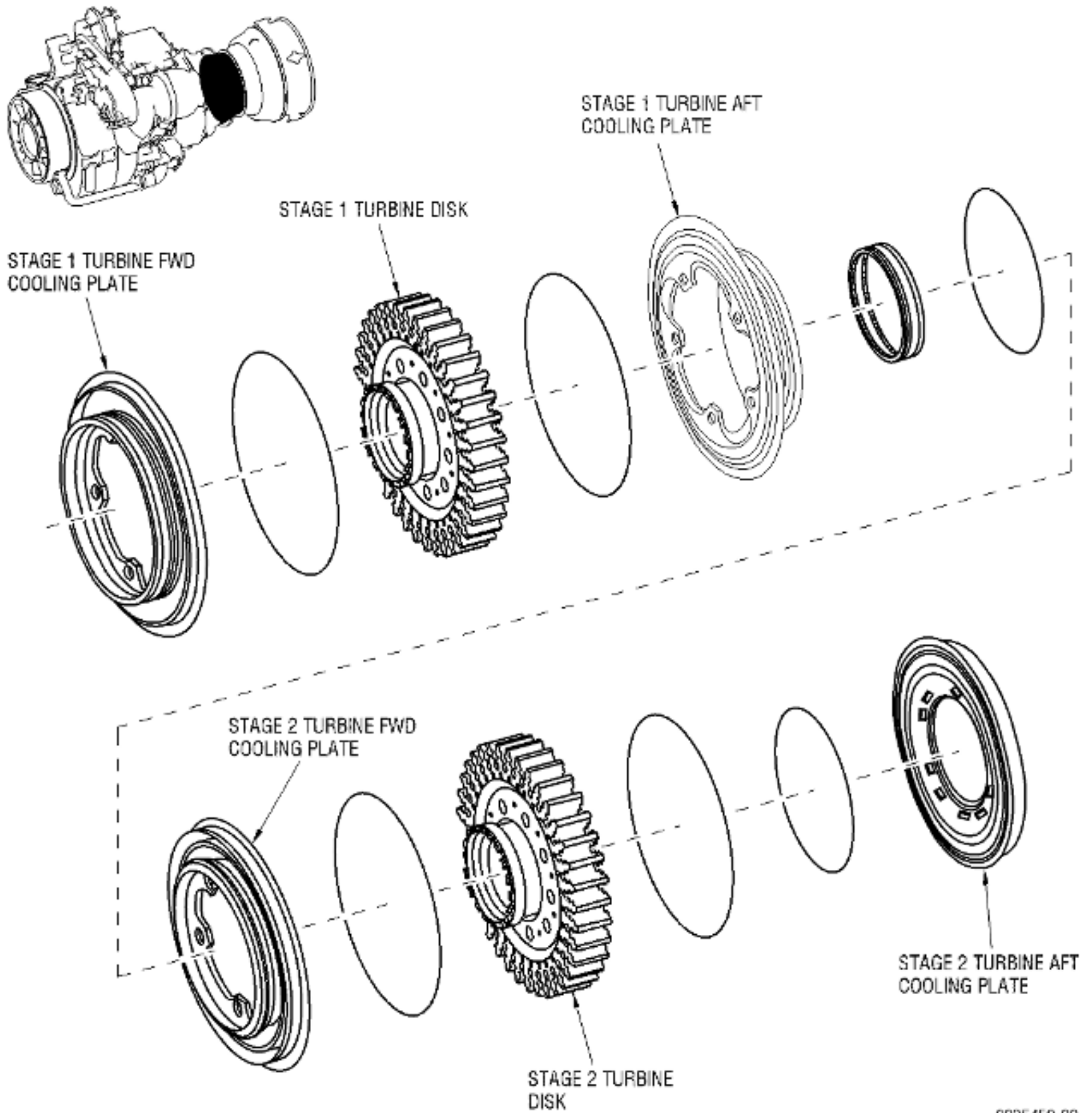

6035459-00

Stages 1 and 2 Low-Stress GGT Rotor Assembly Disks and Cooling Plates  
Figure 1

GE Designated: - CONFIDENTIAL Subject to the restrictions on the media