

HELICOPTER ENGINES

TURBOSHAFT

ARRIEL 2 C1

MAINTENANCE MANUAL

TROUBLE SHOOTING

No. X 292 N4 450 2

Original issue: Aug. 16/1998

Update No. 53: Dec. 30/2023



64511 BORDES CEDEX - FRANCE - Tel.: +33 (0)5 59 12 50 00

www.safran-helicopter-engines.com

LETTER

This covering letter is not part of the MAINTENANCE MANUAL.
Do not keep it on the MAINTENANCE MANUAL.

Bordes, Dec. 30/2023

Dear Sir / Madam,

The *ARRIEL 2 C1 MAINTENANCE MANUAL No. X 292 N4 450 2* has been subject to normal update No. 53 on Dec. 30/2023.

A description of the update (description, pages to be removed or inserted) is provided below.

We remain at your disposal for any further information you may require. Very truly yours

Technical Publications

Task Number	Description	Pages to be removed	Pages to be inserted
Title Page	Integration	ALL	1
LAP - 71	Integration	ALL	1 to 6
71-00-06-814-801-A01	Integration	ALL	101 to 104
71-00-06-814-801-B01	Integration	ALL	101 to 104

CHAPTER 71 - LIST OF EFFECTIVE PAGES

<u>Chapter</u> <u>Section</u> <u>Subject</u>	<u>Task</u>	<u>Title</u>	<u>Pages</u>	<u>Date</u>
71		LIST OF EFFECTIVE PAGES	* 1 - 6	Dec. 30/2023
71		TABLE OF CONTENTS	1 - 6	June 15/2023
71-00-06	INT-802-A01	TROUBLESHOOTING - INTRODUCTION	1 - 24	Dec. 30/2021
71-00-06	RPU-801-A01	FAILURES FOUND DURING OPERATION - LIST OF FAILURES OBSERVED DURING ENGINE OPERATION	101 - 104	Dec. 30/2021
71-00-06	RPM-802-A01	LIST OF FAILURES FOUND DURING MAINTENANCE - LIST OF FAILURES OBSERVED DURING MAINTENANCE	101 - 102	June 15/2023
71-00-06	RPA-803-A01	LIST OF FAILURES CODES - LIST OF FAILURE CODES	101 - 104	Nov. 30/2012
71-00-06	811-801-A01	FUEL FILT ON - PRE-BLOCKAGE SIGNAL OF THE FUEL FILTERING ELEMENT - TROUBLESHOOTING	101 - 102	Nov. 30/2009
71-00-06	811-802-A01	FUEL P OFF - NO LOW FUEL PRESSURE SIGNAL - TROUBLESHOOTING	101 - 104	Nov. 30/2009
71-00-06	811-803-A01	ENG P OFF - NO LOW OIL PRESSURE SIGNAL - TROUBLESHOOTING	101 - 104	May 30/2010
71-00-06	811-804-A01	RED GOV OR AMBER GOV OR FLASHING GOV ON - LIGHTING OF GOV WARNING LIGHT - TROUBLESHOOTING	101 - 102	May 30/2010
71-00-06	811-806-A01	NO ILLUMINATION OF FADEC AND GOV LIGHTS DURING EECU SELF TEST - TROUBLESHOOTING	101 - 104	Dec. 30/2021
71-00-06	811-808-A01	RED GOV AT POWER ON - TROUBLESHOOTING	101 - 104	Dec. 30/2021
71-00-06	812-802-A01	FUEL P ON - NO EXTINGUISHING OF THE LOW FUEL PRESSURE SIGNAL - TROUBLESHOOTING	101 - 104	Nov. 30/2009
71-00-06	812-804-A01	ENGINE PARAMETER OUT OF LIMIT - T4.5 LIMITATIONS EXCEEDED - TROUBLESHOOTING	101 - 106	Nov. 30/2017
71-00-06	812-805-A01	ABORTED START - GAS GENERATOR NOT DRIVEN - TROUBLESHOOTING	101 - 108	June 15/2020

* Page modified following update No. 53

SAFRAN HELICOPTER ENGINES

ARRIEL 2 C1

MAINTENANCE MANUAL

<u>Chapter Section Subject</u>	<u>Task</u>	<u>Title</u>	<u>Pages</u>	<u>Date</u>
71-00-06	812-806-A01	ENG P ON - NO EXTINGUISHING OF THE LOW OIL PRESSURE SIGNAL - TROUBLESHOOTING	101 - 102	May 30/2010
71-00-06	812-807-A01	ABORTED START - NO IGNITION - TROUBLESHOOTING	101 - 112	Dec. 30/2021
71-00-06	812-808-A01	ABORTED START - SLOW START OR STAGNATION - TROUBLESHOOTING	101 - 108	Dec. 30/2020
71-00-06	812-810-A01	ABORTED START - FLAME OUT - TROUBLESHOOTING	101 - 104	June 15/2020
71-00-06	812-811-A01	ABORTED START - FIRST START ABORTED - TROUBLESHOOTING	101 - 104	June 15/2021
71-00-06	812-812-A01	ABORTED START - FLAMES AT THE EXHAUST PIPE - TROUBLESHOOTING	101 - 104	Dec. 30/2020
71-00-06	812-813-A01	NO OIL PRESSURE RISE AT STARTING - TROUBLESHOOTING	101 - 104	June 15/2020
71-00-06	812-816-A01	HELICOPTER ROTOR MOVEMENT THAT OCCURS AFTER THE USUAL TIME DURING ENGINE START - TROUBLESHOOTING	101 - 104	Dec. 30/2019
71-00-06	813-801-A01	SURGE - TROUBLESHOOTING	101 - 106	June 15/2021
71-00-06	814-801-A01	ENG CHIP ON - INDICATOR LIGHT OF THE ELECTRICAL MAGNETIC PLUG ON - TROUBLESHOOTING	* 101 - 104	Dec. 30/2023
71-00-06	814-801-B01	ENG CHIP ON - INDICATOR LIGHT OF THE ELECTRICAL MAGNETIC PLUG ON - TROUBLESHOOTING	* 101 - 104	Dec. 30/2023
71-00-06	814-802-A01	FUEL FILT ON - PRE-BLOCKAGE SIGNAL OF THE FUEL FILTERING ELEMENT - TROUBLESHOOTING	101 - 104	June 15/2023
71-00-06	814-803-A01	FUEL P ON - LOW FUEL PRESSURE SIGNAL - TROUBLESHOOTING	101 - 104	Nov. 30/2009
71-00-06	814-805-A01	ENGINE PARAMETER OUT OF LIMIT - TORQUE LIMITATIONS EXCEEDED - TROUBLESHOOTING	101 - 102	Dec. 30/2020
71-00-06	814-806-A01	ENGINE PARAMETER OUT OF LIMIT - N1 LIMITATIONS EXCEEDED - TROUBLESHOOTING	101 - 102	Nov. 30/2017

* Page modified following update No. 53

List of Effective Pages

71

Page 2
Dec. 30/2023

SAFRAN HELICOPTER ENGINES

ARRIEL 2 C1

MAINTENANCE MANUAL

<u>Chapter Section Subject</u>	<u>Task</u>	<u>Title</u>	<u>Pages</u>	<u>Date</u>
71-00-06	814-807-A01	ENGINE PARAMETER OUT OF LIMIT - N2 LIMITATIONS EXCEEDED - TROUBLESHOOTING	101 - 102	Nov. 30/2017
71-00-06	814-808-A01	PARAMETER INSTABILITY - OIL PRESSURE - TROUBLESHOOTING	101 - 102	Nov. 30/2015
71-00-06	814-809-A01	ENG P ON - LOW OIL PRESSURE SIGNAL - TROUBLESHOOTING	101 - 104	May 30/2010
71-00-06	814-810-A01	ENGINE PARAMETER OUT OF LIMIT - OIL OVERTEMPERATURE - TROUBLESHOOTING	101 - 104	July 30/2012
71-00-06	814-812-A01	PARAMETER INSTABILITY - TORQUE - TROUBLESHOOTING	101 - 102	Nov. 30/2015
71-00-06	815-801-A01	UNUSUAL NOISES DURING RUNDOWN PHASE - TROUBLESHOOTING	101 - 108	Dec. 30/2022
71-00-06	815-802-A01	RUNDOWN TIME OUT OF LIMIT - TROUBLESHOOTING	101 - 112	Dec. 30/2022
71-00-06	815-804-A01	FUEL P OFF - NO LOW FUEL PRESSURE SIGNAL - TROUBLESHOOTING	101 - 102	Nov. 30/2009
71-00-06	815-805-A01	ENG P OFF - NO LOW OIL PRESSURE SIGNAL - TROUBLESHOOTING	101 - 102	May 30/2010
71-00-06	815-806-A01	POWER TURBINE BLOCKED - TROUBLESHOOTING	101 - 102	Dec. 30/2019
71-00-06	816-801-A01	SMOKE FROM EXHAUST PIPE - TROUBLESHOOTING	101 - 106	Dec. 30/2021
71-00-06	816-803-A01	PARTICLES IN THE OIL FILTERING ELEMENT - TROUBLESHOOTING	101 - 102	May 30/2011
71-00-06	816-804-B01	LEAK AT THE AIRCRAFT DRAIN CLUSTER - TROUBLESHOOTING	101 - 104	June 15/2019
71-00-06	816-805-A01	ABNORMAL FUEL LEAKAGE AT THE TANK RETURN FUEL TUBE - TROUBLESHOOTING	101 - 102	Dec. 30/2018
71-00-06	816-806-A01	FUEL FILTER CLOGGING INDICATOR POPPED OUT - TROUBLESHOOTING	101 - 104	June 15/2023
71-00-06	816-807-A01	FUEL DILUTION RATE IN OIL NOT COMPLIANT - TROUBLESHOOTING	101 - 102	Dec. 30/2021
71-00-06	816-808-A01	INCORRECT OPERATION OF ONE OF THE IGNITION DEVICE LINES - TROUBLESHOOTING	101 - 102	Nov. 30/2009

* Page modified following update No. 53

SAFRAN HELICOPTER ENGINES

ARRIEL 2 C1

MAINTENANCE MANUAL

<u>Chapter Section Subject</u>	<u>Task</u>	<u>Title</u>	<u>Pages</u>	<u>Date</u>
71-00-06	816-810-A01	PARTICLES ON A MAGNETIC PLUG - TROUBLESHOOTING	101 - 102	May 30/2011
71-00-06	816-811-A01	NON CONFORM OIL CONSUMPTION - TROUBLESHOOTING	101 - 110	Dec. 30/2020
71-00-06	816-812-A01	CHECK OF ABNORMAL OIL PRESSURE - TROUBLESHOOTING	101 - 108	Dec. 30/2020
71-00-06	816-813-A01	POPPING OUT OF THE PRE-BLOCKAGE INDICATOR OF THE OIL FILTER - TROUBLESHOOTING	101 - 104	June 15/2020
71-00-06	816-814-A01	OIL LEAKAGE BETWEEN M03 AND M04 - TROUBLESHOOTING	101 - 104	June 15/2021
71-00-06	816-815-A01	VIBRATION OUT OF TOLERANCE DETECTED BY THE M'ARMS SYSTEM - TROUBLESHOOTING	101 - 112	Dec. 30/2021
71-00-06	816-819-A01	ENGINE POWER CHECK - INCORRECT MARGIN - TROUBLESHOOTING	101 - 128	June 15/2022
71-00-06	816-821-A01	FUEL ODOR IN THE CABIN - TROUBLESHOOTING	101 - 102	Dec. 30/2021
71-00-06	816-825-A01	OIL LEAK AT BLEED VALVE OR AIR INTAKE - TROUBLESHOOTING	101 - 102	June 15/2023
71-00-06	816-827-A01	OIL LEAKAGE OF THE POWER DRIVE OF THE STARTER - TROUBLESHOOTING	101 - 102	June 15/2021
71-00-06	816-833-A01	OIL TANK LEVEL SLOWLY DECREASES AFTER ENGINE SHUTDOWN - TROUBLESHOOTING	101 - 102	Dec. 30/2021
71-00-06	817-801-A01	WATCHDOG TRIP - TROUBLESHOOTING	101 - 104	Dec. 30/2021
71-00-06	817-803-A01	N2 TRIM FAILURE, CHANNEL A - TROUBLESHOOTING	101 - 102	May 30/2010
71-00-06	817-804-A01	N2 TRIM FAILURE, CHANNEL B - TROUBLESHOOTING	101 - 102	May 30/2010
71-00-06	817-805-A01	TRAINING SELECTOR FAILURE - TROUBLESHOOTING	101 - 104	Dec. 30/2021
71-00-06	817-808-A01	OFF/IDLE/FLIGHT SELECTOR FAILURE - TROUBLESHOOTING	101 - 104	Dec. 30/2021
71-00-06	817-810-A01	T1 INCONSISTENCY - TROUBLESHOOTING	101 - 104	Dec. 30/2021

* Page modified following update No. 53

List of Effective Pages

71

Page 4
Dec. 30/2023

<u>Chapter Section Subject</u>	<u>Task</u>	<u>Title</u>	<u>Pages</u>	<u>Date</u>
71-00-06	817-823-A01	COLLECTIVE PITCH FAILURE - TROUBLESHOOTING	101 - 104	Dec. 30/2021
71-00-06	817-825-A01	TOT (T4) FAIL - TROUBLESHOOTING	101 - 106	Dec. 30/2021
71-00-06	817-828-A01	T0 FAIL - TROUBLESHOOTING	101 - 104	Dec. 30/2021
71-00-06	817-833-A01	P3 FAILURE - TROUBLESHOOTING	101 - 104	Dec. 30/2021
71-00-06	817-842-A01	RAW TORQUE FAILURE - TROUBLESHOOTING	101 - 104	Dec. 30/2021
71-00-06	817-844-A01	TOT (T4) CONFORMATION FAIL - TROUBLESHOOTING	101 - 104	Dec. 30/2021
71-00-06	817-847-A01	TORQUE CONFORMATION FAIL - TROUBLESHOOTING	101 - 104	Dec. 30/2021
71-00-06	817-861-A01	EECU INTERNAL FAILURE - TROUBLESHOOTING	101 - 104	Dec. 30/2021
71-00-06	817-864-A01	P3 DRIFT - TROUBLESHOOTING	101 - 104	Dec. 30/2021
71-00-06	817-869-A01	P0 EECU - TROUBLESHOOTING	101 - 102	Dec. 30/2021
71-00-06	817-878-A01	FUEL VALVE RESOLVER FAILURE - TROUBLESHOOTING	101 - 106	Dec. 30/2021
71-00-06	817-880-A01	STEPPER MOTOR FAILURE A - TROUBLESHOOTING	101 - 104	Dec. 30/2021
71-00-06	817-881-A01	STEPPER MOTOR FAILURE B - TROUBLESHOOTING	101 - 104	Dec. 30/2021
71-00-06	817-882-A01	STEPPER MOTOR FAILURE - TROUBLESHOOTING	101 - 104	Dec. 30/2019
71-00-06	817-884-A01	BLEED VALVE POSITION INCONSISTENCY OR BLEED VALVE ANOMALY OBSERVED - TROUBLESHOOTING	101 - 112	Dec. 30/2021
71-00-06	817-889-A01	HELICOPTER T4.5 FAILURE - TROUBLESHOOTING	101 - 106	Dec. 30/2020
71-00-06	817-890-A01	CROSS TALK ARINC - TROUBLESHOOTING	101 - 104	Dec. 30/2021
71-00-06	817-905-A01	NR FAILURE - TROUBLESHOOTING	101 - 102	Nov. 30/2009
71-00-06	817-906-A01	DECU CONFIGURATION/AIRCRAFT CONFIGURATION INCONSISTENCY - TROUBLESHOOTING	101 - 102	Dec. 30/2019
71-00-06	817-907-A01	N2 FAILURE (B ON THE HARNESS) - TROUBLESHOOTING	101 - 104	Dec. 30/2021

* Page modified following update No. 53

<u>Chapter Section Subject</u>	<u>Task</u>	<u>Title</u>	<u>Pages</u>	<u>Date</u>
71-00-06	817-910-A01	INTERCHANNEL RECEPTION FAILURE - TROUBLESHOOTING	101 - 102	Dec. 30/2021
71-00-06	817-913-A01	N2 FAILURE (C ON THE HARNESS) - TROUBLESHOOTING	101 - 104	Dec. 30/2021
71-00-06	817-918-A01	N1 FAILURE (A ALTERNATOR ON THE HARNESS) - TROUBLESHOOTING	101 - 104	Dec. 30/2021
71-00-06	817-919-A01	N1 FAILURE (B ALTERNATOR ON THE HARNESS) - TROUBLESHOOTING	101 - 104	Dec. 30/2021
71-00-06	817-920-A01	N1 FAILURE ON THE ALTERNATOR ELECTRICAL CONNECTOR (A ALTERNATOR ON THE HARNESS AND B ALTERNATOR ON THE HARNESS) - TROUBLESHOOTING	101 - 104	Dec. 30/2021
71-00-06	817-928-A01	HELICOPTER P0 FAILURE - TROUBLESHOOTING	101 - 102	Dec. 30/2019
71-00-06	817-929-A01	NO HELICOPTER ARINC MESSAGE - TROUBLESHOOTING	101 - 104	Dec. 30/2021
71-00-06	817-931-A01	ALTERNATOR FAILURE CHANNEL A AND CHANNEL B - TROUBLESHOOTING	101 - 104	Dec. 30/2021
71-00-06	817-932-A01	ALTERNATOR FAILURE A - TROUBLESHOOTING	101 - 104	Dec. 30/2021
71-00-06	817-933-A01	ALTERNATOR FAILURE B - TROUBLESHOOTING	101 - 104	Dec. 30/2021
71-00-06	817-938-A01	28V FAILURE A - TROUBLESHOOTING	101 - 104	Dec. 30/2021
71-00-06	817-939-A01	28V FAILURE B - TROUBLESHOOTING	101 - 104	Dec. 30/2021
71-00-06	817-948-A01	P0 INCONSISTENCY - TROUBLESHOOTING	101 - 102	Dec. 30/2021
71-00-06	817-949-A01	STOP ELECTRO-VALVE FAILURE - TROUBLESHOOTING	101 - 106	Dec. 30/2021
71-00-06	817-955-A01	OVERSPEED PROTECTION FAILURE - TROUBLESHOOTING	101 - 108	June 15/2021
71-00-06	817-959-A01	REAL TIME SOFTWARE FAILURE - TROUBLESHOOTING	101 - 102	Dec. 30/2021
71-00-06	817-966-A01	HMU OUT OF NEUTRAL POSITION - TROUBLESHOOTING	101 - 104	June 15/2020

* Page modified following update No. 53

CHAPTER 71 - TABLE OF CONTENTS

<u>Title</u>	<u>Chapter Section Subject</u>	<u>Task</u>	<u>Effectivity</u>
TURBOSHAFT ENGINE - POWERPLANT	71		
TROUBLESHOOTING	71-00-00		
• TROUBLESHOOTING - INTRODUCTION	71-00-06		
• FAILURES FOUND DURING OPERATION - LIST OF FAILURES OBSERVED DURING ENGINE OPERATION	71-00-06		
• LIST OF FAILURES FOUND DURING MAINTENANCE - LIST OF FAILURES OBSERVED DURING MAINTENANCE	71-00-06		
• LIST OF FAILURES CODES - LIST OF FAILURE CODES	71-00-06		
• FUEL FILT ON - PRE-BLOCKAGE SIGNAL OF THE FUEL FILTERING ELEMENT - TROUBLESHOOTING	71-00-06	811-801-A01	
• FUEL P OFF - NO LOW FUEL PRESSURE SIGNAL - TROUBLESHOOTING	71-00-06	811-802-A01	
• ENG P OFF - NO LOW OIL PRESSURE SIGNAL - TROUBLESHOOTING	71-00-06	811-803-A01	
• RED GOV OR AMBER GOV OR FLASHING GOV ON - LIGHTING OF GOV WARNING LIGHT - TROUBLESHOOTING	71-00-06	811-804-A01	
• NO ILLUMINATION OF FADEC AND GOV LIGHTS DURING EECU SELF TEST - TROUBLESHOOTING	71-00-06	811-806-A01	
• RED GOV AT POWER ON - TROUBLESHOOTING	71-00-06	811-808-A01	
• FUEL P ON - NO EXTINGUISHING OF THE LOW FUEL PRESSURE SIGNAL - TROUBLESHOOTING	71-00-06	812-802-A01	
• ENGINE PARAMETER OUT OF LIMIT - T4.5 LIMITATIONS EXCEEDED - TROUBLESHOOTING	71-00-06	812-804-A01	
• ABORTED START - GAS GENERATOR NOT DRIVEN - TROUBLESHOOTING	71-00-06	812-805-A01	
• ENG P ON - NO EXTINGUISHING OF THE LOW OIL PRESSURE SIGNAL - TROUBLESHOOTING	71-00-06	812-806-A01	
• ABORTED START - NO IGNITION - TROUBLESHOOTING	71-00-06	812-807-A01	
• ABORTED START - SLOW START OR STAGNATION - TROUBLESHOOTING	71-00-06	812-808-A01	

<u>Title</u>	<u>Chapter Section Subject</u>	<u>Task</u>	<u>Effectivity</u>
• ABORTED START - FLAME OUT - TROUBLESHOOTING	71-00-06	812-810-A01	
• ABORTED START - FIRST START ABORTED - TROUBLESHOOTING	71-00-06	812-811-A01	
• ABORTED START - FLAMES AT THE EXHAUST PIPE - TROUBLESHOOTING	71-00-06	812-812-A01	
• NO OIL PRESSURE RISE AT STARTING - TROUBLESHOOTING	71-00-06	812-813-A01	
• HELICOPTER ROTOR MOVEMENT THAT OCCURS AFTER THE USUAL TIME DURING ENGINE START - TROUBLESHOOTING	71-00-06	812-816-A01	
• SURGE - TROUBLESHOOTING	71-00-06	813-801-A01	
• ENG CHIP ON - INDICATOR LIGHT OF THE ELECTRICAL MAGNETIC PLUG ON - TROUBLESHOOTING	71-00-06	814-801-A01	BASE
• ENG CHIP ON - INDICATOR LIGHT OF THE ELECTRICAL MAGNETIC PLUG ON - TROUBLESHOOTING	71-00-06	814-801-B01	TU 060
• FUEL FILT ON - PRE-BLOCKAGE SIGNAL OF THE FUEL FILTERING ELEMENT - TROUBLESHOOTING	71-00-06	814-802-A01	
• FUEL P ON - LOW FUEL PRESSURE SIGNAL - TROUBLESHOOTING	71-00-06	814-803-A01	
• ENGINE PARAMETER OUT OF LIMIT - TORQUE LIMITATIONS EXCEEDED - TROUBLESHOOTING	71-00-06	814-805-A01	
• ENGINE PARAMETER OUT OF LIMIT - N1 LIMITATIONS EXCEEDED - TROUBLESHOOTING	71-00-06	814-806-A01	
• ENGINE PARAMETER OUT OF LIMIT - N2 LIMITATIONS EXCEEDED - TROUBLESHOOTING	71-00-06	814-807-A01	
• PARAMETER INSTABILITY - OIL PRESSURE - TROUBLESHOOTING	71-00-06	814-808-A01	
• ENG P ON - LOW OIL PRESSURE SIGNAL - TROUBLESHOOTING	71-00-06	814-809-A01	
• ENGINE PARAMETER OUT OF LIMIT - OIL OVERTEMPERATURE - TROUBLESHOOTING	71-00-06	814-810-A01	
• PARAMETER INSTABILITY - TORQUE - TROUBLESHOOTING	71-00-06	814-812-A01	
• UNUSUAL NOISES DURING RUNDOWN PHASE - TROUBLESHOOTING	71-00-06	815-801-A01	
• RUNDOWN TIME OUT OF LIMIT - TROUBLESHOOTING	71-00-06	815-802-A01	

<u>Title</u>	<u>Chapter Section Subject</u>	<u>Task</u>	<u>Effectivity</u>
• FUEL P OFF - NO LOW FUEL PRESSURE SIGNAL - TROUBLESHOOTING	71-00-06	815-804-A01	
• ENG P OFF - NO LOW OIL PRESSURE SIGNAL - TROUBLESHOOTING	71-00-06	815-805-A01	
• POWER TURBINE BLOCKED - TROUBLESHOOTING	71-00-06	815-806-A01	
• SMOKE FROM EXHAUST PIPE - TROUBLESHOOTING	71-00-06	816-801-A01	
• PARTICLES IN THE OIL FILTERING ELEMENT - TROUBLESHOOTING	71-00-06	816-803-A01	
• LEAK AT THE AIRCRAFT DRAIN CLUSTER - TROUBLESHOOTING	71-00-06	816-804-B01	TU 043A
• ABNORMAL FUEL LEAKAGE AT THE TANK RETURN FUEL TUBE - TROUBLESHOOTING	71-00-06	816-805-A01	
• FUEL FILTER CLOGGING INDICATOR POPPED OUT - TROUBLESHOOTING	71-00-06	816-806-A01	
• FUEL DILUTION RATE IN OIL NOT COMPLIANT - TROUBLESHOOTING	71-00-06	816-807-A01	
• INCORRECT OPERATION OF ONE OF THE IGNITION DEVICE LINES - TROUBLESHOOTING	71-00-06	816-808-A01	
• PARTICLES ON A MAGNETIC PLUG - TROUBLESHOOTING	71-00-06	816-810-A01	
• NON CONFORM OIL CONSUMPTION - TROUBLESHOOTING	71-00-06	816-811-A01	
• CHECK OF ABNORMAL OIL PRESSURE - TROUBLESHOOTING	71-00-06	816-812-A01	
• POPPING OUT OF THE PRE-BLOCKAGE INDICATOR OF THE OIL FILTER - TROUBLESHOOTING	71-00-06	816-813-A01	
• OIL LEAKAGE BETWEEN M03 AND M04 - TROUBLESHOOTING	71-00-06	816-814-A01	
• VIBRATION OUT OF TOLERANCE DETECTED BY THE M'ARMS SYSTEM - TROUBLESHOOTING	71-00-06	816-815-A01	
• ENGINE POWER CHECK - INCORRECT MARGIN - TROUBLESHOOTING	71-00-06	816-819-A01	
• FUEL ODOR IN THE CABIN - TROUBLESHOOTING	71-00-06	816-821-A01	
• OIL LEAK AT BLEED VALVE OR AIR INTAKE - TROUBLESHOOTING	71-00-06	816-825-A01	
• OIL LEAKAGE OF THE POWER DRIVE OF THE STARTER - TROUBLESHOOTING	71-00-06	816-827-A01	

<u>Title</u>	<u>Chapter Section Subject</u>	<u>Task</u>	<u>Effectivity</u>
• OIL TANK LEVEL SLOWLY DECREASES AFTER ENGINE SHUTDOWN - TROUBLESHOOTING	71-00-06	816-833-A01	
• WATCHDOG TRIP - TROUBLESHOOTING	71-00-06	817-801-A01	
• N2 TRIM FAILURE, CHANNEL A - TROUBLESHOOTING	71-00-06	817-803-A01	
• N2 TRIM FAILURE, CHANNEL B - TROUBLESHOOTING	71-00-06	817-804-A01	
• TRAINING SELECTOR FAILURE - TROUBLESHOOTING	71-00-06	817-805-A01	
• OFF/IDLE/FLIGHT SELECTOR FAILURE - TROUBLESHOOTING	71-00-06	817-808-A01	
• T1 INCONSISTENCY - TROUBLESHOOTING	71-00-06	817-810-A01	
• COLLECTIVE PITCH FAILURE - TROUBLESHOOTING	71-00-06	817-823-A01	
• TOT (T4) FAIL - TROUBLESHOOTING	71-00-06	817-825-A01	
• T0 FAIL - TROUBLESHOOTING	71-00-06	817-828-A01	
• P3 FAILURE - TROUBLESHOOTING	71-00-06	817-833-A01	
• RAW TORQUE FAILURE - TROUBLESHOOTING	71-00-06	817-842-A01	
• TOT (T4) CONFORMATION FAIL - TROUBLESHOOTING	71-00-06	817-844-A01	
• TORQUE CONFORMATION FAIL - TROUBLESHOOTING	71-00-06	817-847-A01	
• EECU INTERNAL FAILURE - TROUBLESHOOTING	71-00-06	817-861-A01	
• P3 DRIFT - TROUBLESHOOTING	71-00-06	817-864-A01	
• P0 EECU - TROUBLESHOOTING	71-00-06	817-869-A01	
• FUEL VALVE RESOLVER FAILURE - TROUBLESHOOTING	71-00-06	817-878-A01	
• STEPPER MOTOR FAILURE A - TROUBLESHOOTING	71-00-06	817-880-A01	
• STEPPER MOTOR FAILURE B - TROUBLESHOOTING	71-00-06	817-881-A01	
• STEPPER MOTOR FAILURE - TROUBLESHOOTING	71-00-06	817-882-A01	
• BLEED VALVE POSITION INCONSISTENCY OR BLEED VALVE ANOMALY OBSERVED - TROUBLESHOOTING	71-00-06	817-884-A01	
• HELICOPTER T4.5 FAILURE - TROUBLESHOOTING	71-00-06	817-889-A01	
• CROSS TALK ARINC - TROUBLESHOOTING	71-00-06	817-890-A01	

<u>Title</u>	<u>Chapter Section Subject</u>	<u>Task</u>	<u>Effectivity</u>
• NR FAILURE - TROUBLESHOOTING	71-00-06	817-905-A01	
• DECU CONFIGURATION/AIRCRAFT CONFIGURATION INCONSISTENCY - TROUBLESHOOTING	71-00-06	817-906-A01	
• N2 FAILURE (B ON THE HARNESS) - TROUBLESHOOTING	71-00-06	817-907-A01	
• INTERCHANNEL RECEPTION FAILURE - TROUBLESHOOTING	71-00-06	817-910-A01	
• N2 FAILURE (C ON THE HARNESS) - TROUBLESHOOTING	71-00-06	817-913-A01	
• N1 FAILURE (A ALTERNATOR ON THE HARNESS) - TROUBLESHOOTING	71-00-06	817-918-A01	
• N1 FAILURE (B ALTERNATOR ON THE HARNESS) - TROUBLESHOOTING	71-00-06	817-919-A01	
• N1 FAILURE ON THE ALTERNATOR ELECTRICAL CONNECTOR (A ALTERNATOR ON THE HARNESS AND B ALTERNATOR ON THE HARNESS) - TROUBLESHOOTING	71-00-06	817-920-A01	
• HELICOPTER P0 FAILURE - TROUBLESHOOTING	71-00-06	817-928-A01	
• NO HELICOPTER ARINC MESSAGE - TROUBLESHOOTING	71-00-06	817-929-A01	
• ALTERNATOR FAILURE CHANNEL A AND CHANNEL B - TROUBLESHOOTING	71-00-06	817-931-A01	
• ALTERNATOR FAILURE A - TROUBLESHOOTING	71-00-06	817-932-A01	
• ALTERNATOR FAILURE B - TROUBLESHOOTING	71-00-06	817-933-A01	
• 28V FAILURE A - TROUBLESHOOTING	71-00-06	817-938-A01	
• 28V FAILURE B - TROUBLESHOOTING	71-00-06	817-939-A01	
• P0 INCONSISTENCY - TROUBLESHOOTING	71-00-06	817-948-A01	
• STOP ELECTRO-VALVE FAILURE - TROUBLESHOOTING	71-00-06	817-949-A01	
• OVERSPEED PROTECTION FAILURE - TROUBLESHOOTING	71-00-06	817-955-A01	
• REAL TIME SOFTWARE FAILURE - TROUBLESHOOTING	71-00-06	817-959-A01	
• HMU OUT OF NEUTRAL POSITION - TROUBLESHOOTING	71-00-06	817-966-A01	

PAGE LEFT BLANK INTENTIONALLY

TROUBLESHOOTING - INTRODUCTION

1. GENERAL

This document contains some data extracted from the ARRIEL Maintenance Manual, chapter 71-00-06 - Trouble shooting.

It is devoted to the engine maintenance personnel for finding possible failures.

For Legibility purpose, this manual is divided up into 6 sections:

- Section 1: List of effective pages, contents
- Section 2: introduction, this section gives the manual Lay-out and the general
- Section 3: list of failures observed during use
- Section 4: List of failures observed during maintenance
- Section 5: List of VEMD failure messages
- Section 6: maintenance tasks from the above lists.

These non exhaustive Lists and trouble shootings are drawn up and completed as experience is gained on the engine.

2. INTRODUCTION

A. Description

Refer to Figure 001

There are two main indicating devices in the cockpit: the CPDS (Central Panel Display System) and the warning panel.

The CPDS includes the VEMD (Vehicle and Engine Multifunction Display) and CAD (Caution and Advisories Display).

The VEMD displays all the necessary vehicle and engine parameters. It can also display maintenance information when the aircraft is on the ground. It has an upper and lower screen for selecting the various functions.

The CAD records and displays the cautions and advisories to the pilot relating to the main systems of the engine and the aircraft. It is used as the VEMD back-up when failures occur on screens or modules. It has a screen with pushbuttons enabling selection of the different functions.

The Central Warning Panel has a set of warning lights to alert the pilot in case of operation anomaly.

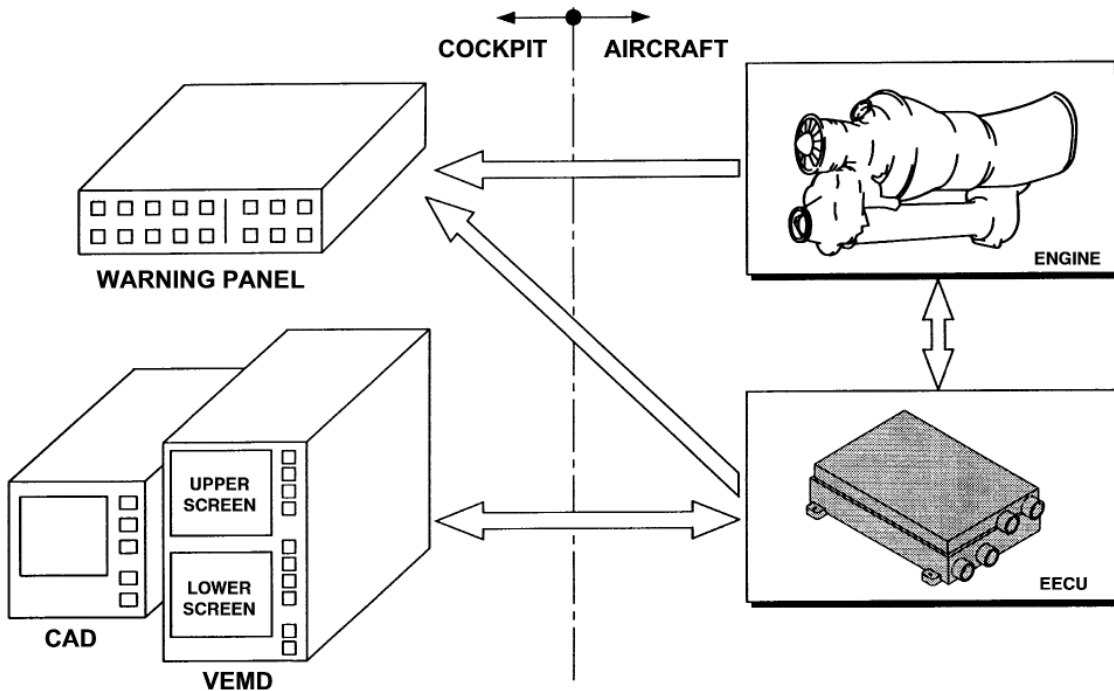

Engine indication in the cockpit - Description

Figure 001

B. CPDS

The CPDS has 3 operating modes:

- The operational mode ("FLIGHT" mode)
- The maintenance mode ("MAINT" mode)
- The configuration mode ("CONFIG" mode).

(1) Operational mode ("FLIGHT" mode)

This mode has several screen pages:

- The initial configuration that the pilot can use in flight to check the aircraft performance (FLI/ELEC/VEH on the VEMD and CAU/FUEL on the CAD).
- The pages accessible on the VEMD lower screen pressing the "SCROLL" key (EPC, PERFO and SYSTEM STATUS).
- The automatic reconfiguration at the end of the flight on the VEMD lower screen (FLIGHT REPORT page).
- A page on the CAD when both VEMD screens are not available (CAU/DELTA N1 page).

In these pages, the displays are as follows:

(a) Initial configuration Refer to Figure 002

1 Upper screen (FLI page):

High information zone for each engine:

- Bleed valve flag
- P2 (sand filter)
- Engine normal limitations: MPC (PMC) MTOP (PMD)
- OEI indications (LO, HI)
- Training mode indication.

FLI zone, for each engine:

- Numeric torque
- Numeric T4.5
- Numeric N1.

FLI means First Limit Indication, it is a graduated analog indicator.

The indicator needle is positioned as a function of the parameter which is nearest to its limits.

The parameters used are N1, T4.5 and Torque.

When the needle reaches the MTOP (PMD) indication, one of the parameters has reached its take-off limit. There is a numeric indication of each parameter for each engine and on both sides of the FLI indicator.

When a parameter approaches its limits, a yellow line flashes under the numerical display; when it reaches the limit, the line becomes red and an aural alarm sounds.

Low information zone for each engine:

- Start indication
- Display of "FLI DEGR" and "FLI FAIL" messages corresponding to a sensor loss or FLI loss.

Message zone: Display of some messages devoted to the crew members (one message at a time on one line).

NOTE: *Safran Helicopter Engines uses the terminology defined in the ARP 755a document, such as T4.5 and P3, nevertheless ECF uses TOT and P2 for this same value.*

NOTE: *FLI (First Limit Indication) can be replaced in french with IPL (Indicateur de Première Limite).*

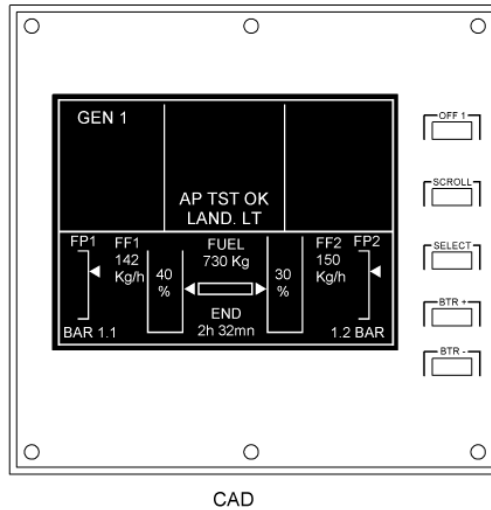
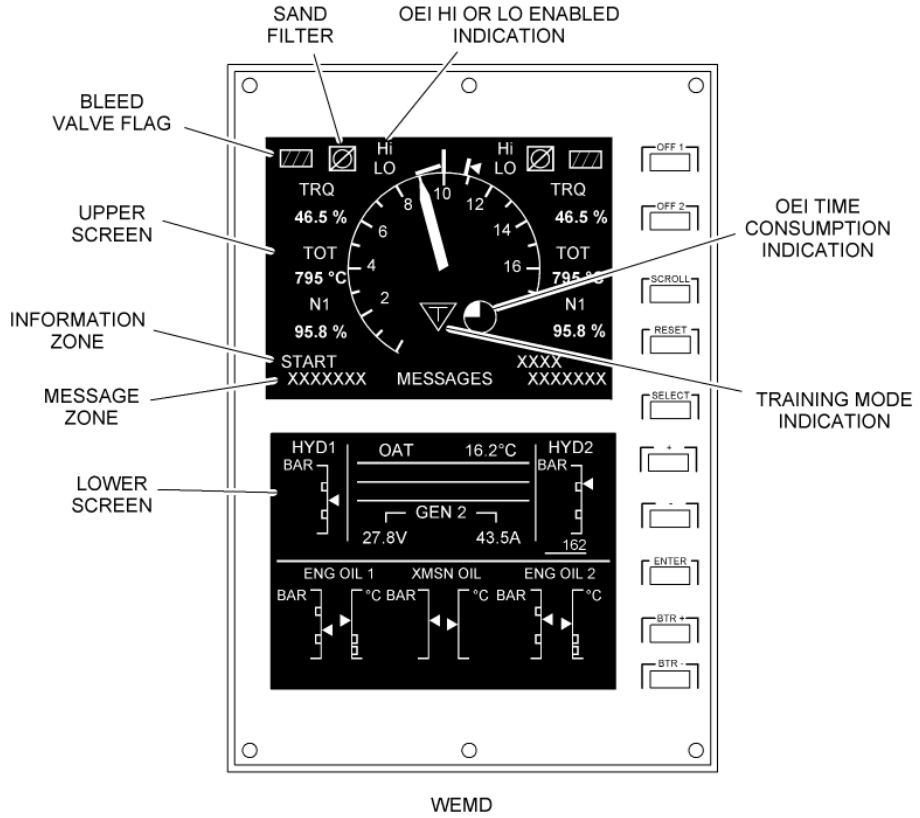

Operational mode - Operation

Figure 002

2 Lower screen (ELEC/VEH page):

- Numeric OAT
- Numeric main bus voltage
- Numeric starter current
- Numeric MGB oil temperature and bargraph animation
- pMGB oil pressure and bargraph animation
- VNE (Never exceeded Speed)
- Sling load.

For each engine:

- Numeric engine oil temperature and bargraph animation
- Numeric engine oil pressure and bargraph animation
- Numeric hydraulic pressure and bargraph animation.

3 CAD screen (CAU/FUEL page):

- Remaining numeric flight time
- Numeric fuel quantity and bargraph.

For each engine:

- Cautions and advisories
- Numeric fuel flow
- Numeric engine fuel pressure and bargraph animation.

(b) Pages accessible on the VEMD bargraph pressing the "SCROLL" key
Refer to Figure 003

1 EPC page (Engine Power Check)

The Engine Power Check is activated automatically when the pilot depresses the "SCROLL" key. The results are displayed on another page and recorded to be accessible in the maintenance mode.

2 PERFO page (Performance)

This page shows the performance accessible as a function of the weight breakdown.

3 SYSTEM STATUS page

This is an alphanumeric page which includes the information transmitted by the EECU of each engine:

- A "MESS" line which corresponds to the state word
- A "FAIL" line which corresponds to the failure word
- The numeric values, names and measuring units of 9 parameters.

To select and move from one line to the other, use the "SELECT" key. A white frame surrounds the selected line. "+/-" keys are used to make the different messages of each line scroll.

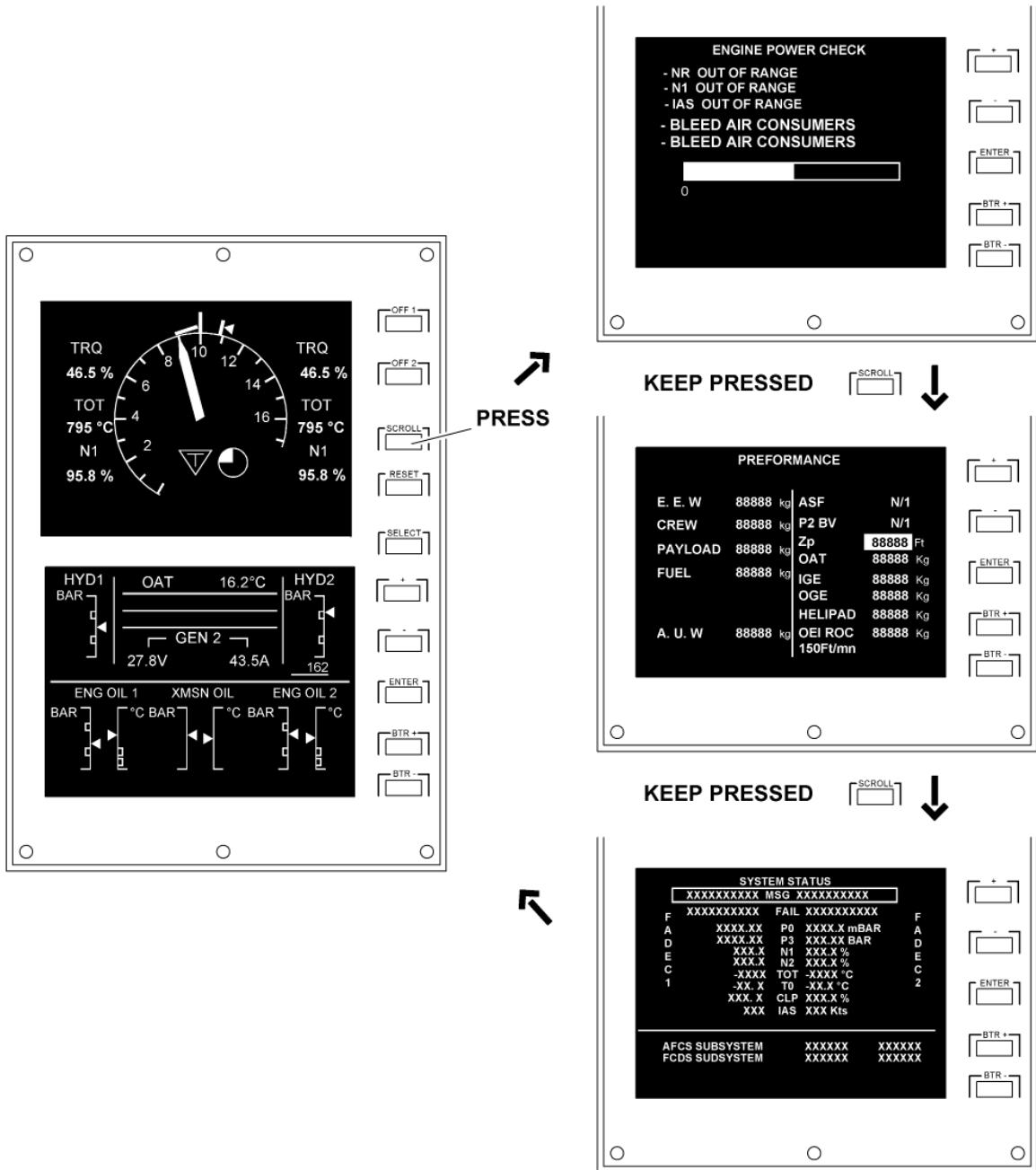

Operational mode - Operation

Figure 003

- (c) Automatic reconfiguration at the end of the flight on the lower screen of the VEMD
Refer to Figure 004

1 FLIGHT REPORT page

The Flight Report is automatically displayed at the end of the flight. It supplies the information below:

- The flight number
- The flight time
- N1 and N2 cycles, those of the flight and all cycles
- Over Limit flag in case of exceedance
- Failure flag (failure) in case of failure.

This page is memorized and is only accessible in the maintenance mode.

ARRIEL 2 C1

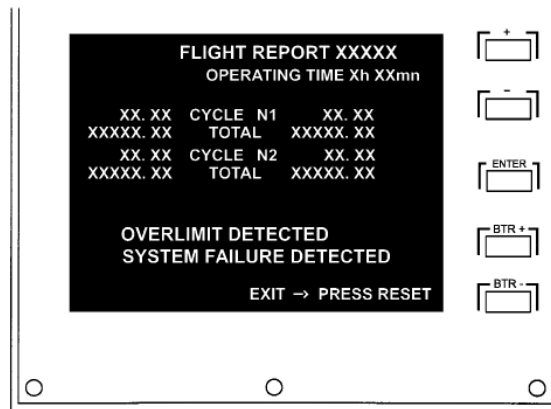

Operational mode - Operation

Figure 004

(d) When both VEMD screens are not available Refer to Figure 005

1 CAD screen (CAU/DELTA N1 page)

– Cautions and advisories.

For each engine: Analog delta N1

ARRIEL 2 C1

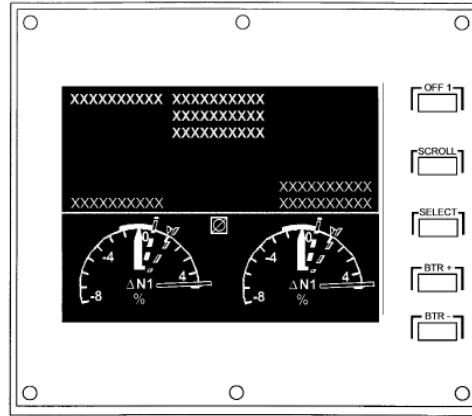

Operational mode - Operation

Figure 005

(2) Maintenance mode ("MAINT" mode) Refer to Figure 006

This mode can only be activated when the engine is detected in the "shutdown" state and the VEMD is set to OFF.

To get access to the maintenance pages, depress the "SCROLL" and "RESET" keys simultaneously, keeping them depressed, turn on the VEMD using the OFF 1 and OFF 2 keys.

On the Maintenance Menu page, use the "SELECT" key to select the line and the "ENTER" key to go to the selected line.

In the maintenance mode, the pages below are displayed: Refer to Figure 007

- FLIGHT REPORT,
- FAILURE,
- OVER LIMIT,
- ENGINE POWER CHECK,
- TRANS. DATA,
- FUNCT. TIMES.

FLIGHT REPORT: this page is automatically displayed at the end of the flight on the lower screen and is identical to the operational mode ("FLIGHT" mode).

(a) Flight Report

This page displays the last 16 recorded flights.

(b) Failure

The failures are displayed on four pages:

- Failure Diagnosis
- Subsystem Sélection
- Complet Diagnosis
- Parameters (6 pages).

"+/-" keys are used to select the flights from the Failure Diagnosis page or the failures from the Complete Diagnosis page. The "SELECT" key is used to select the VEMD or CAD sub-system from the Subsystem Selection page. The "ENTER" key is used to move from one page to another.

(c) Over Limit

This page displays the limits exceedance recorded during the last flights.

(d) Engine Power Check

The last 8 results of the Power Check are displayed.

(e) Trans. Data

This function is used to transfer the information between both modules of the VEMD.

(f) Func. Times

This page displays the total operating hours of the VEMD and of the engine.

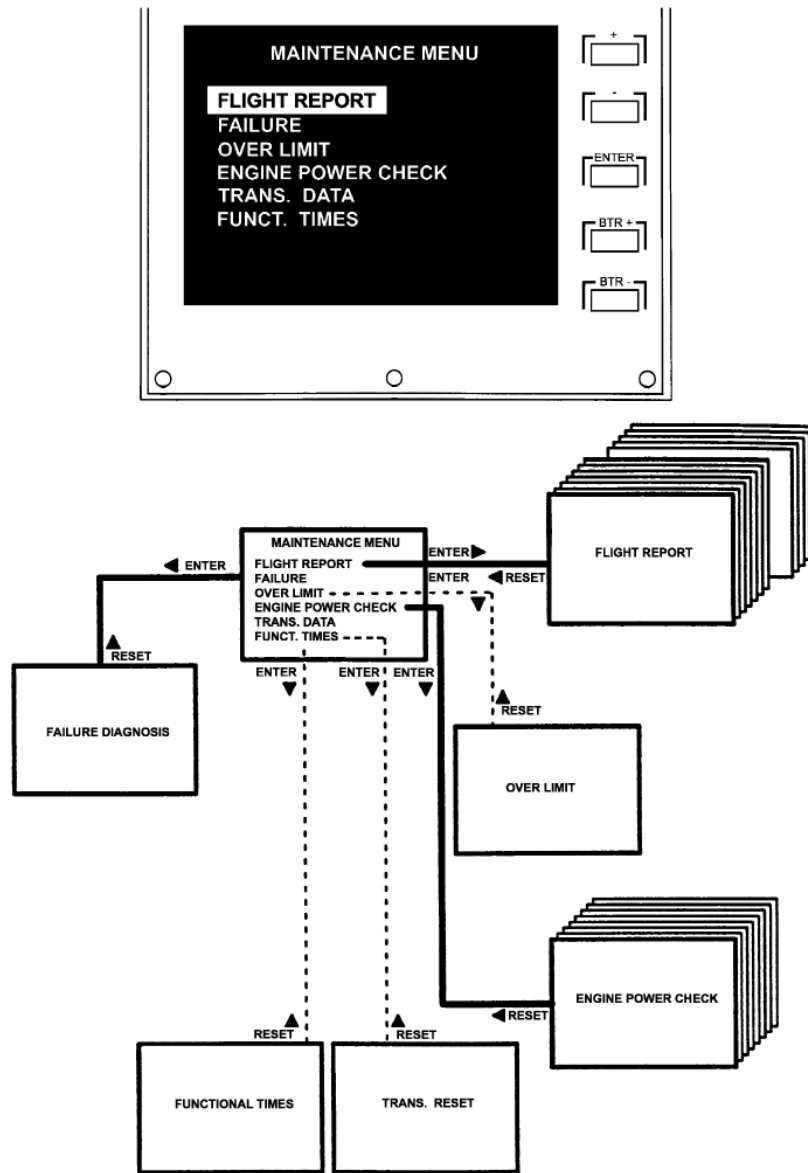

Maintenance mode - Description

Figure 006

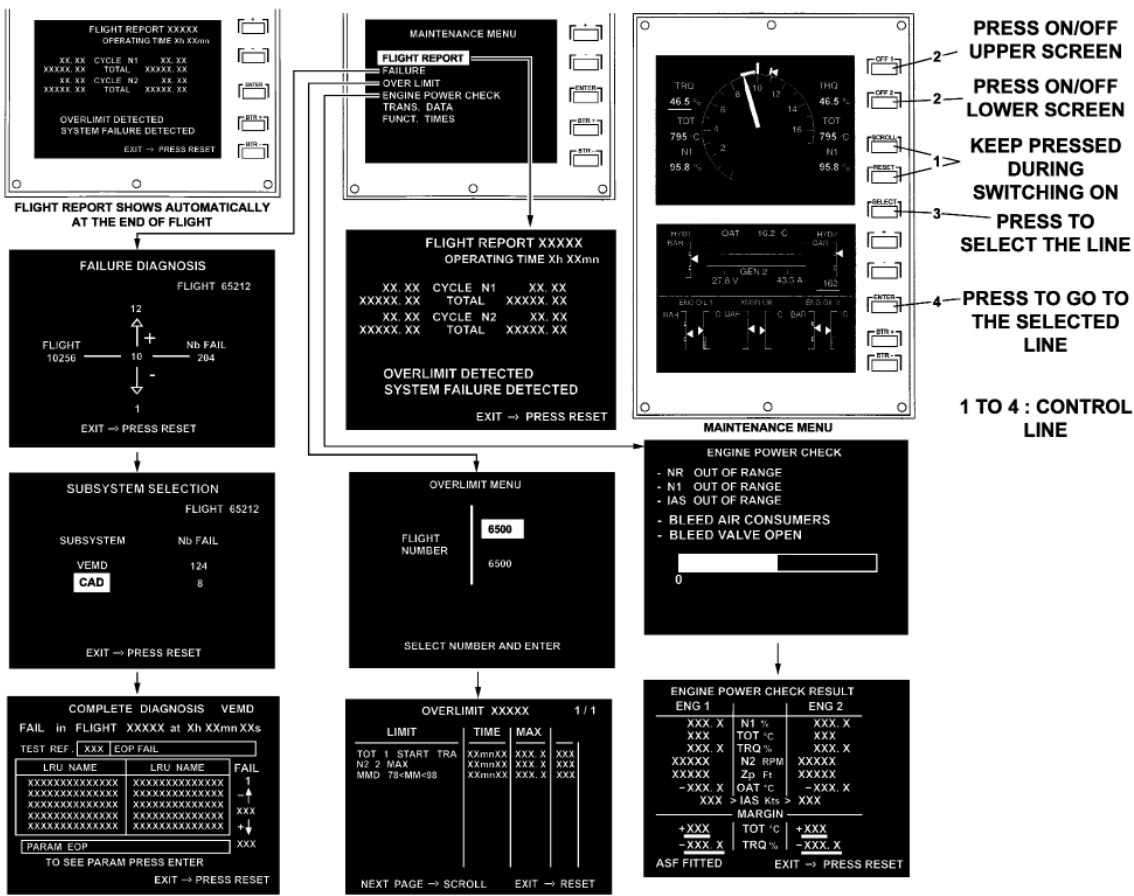

Maintenance mode - Menus

Figure 007

C. Warning light table

Three central warning panel lights indicate an engine operating anomaly. The engine indicating system supplies such information. Refer to Figure 008.

Indicator light	Designation	Color	Definition	Data from
1	ENG 1 et ENG 2	Red	Min. engine oil pressure	Engine sensor
2	GOV 1 et GOV 2	Red	Major failure or engine power anomaly	EECU
3	Diff. N1	Red	N1 deviation	"Power loss" board

NOTE: *The minor failure is indicated by an amber GOV warning light when N1 < 20 %.*

The redundancy failure is indicated by the flashing of the amber GOV warning light when N1 < 20 %.

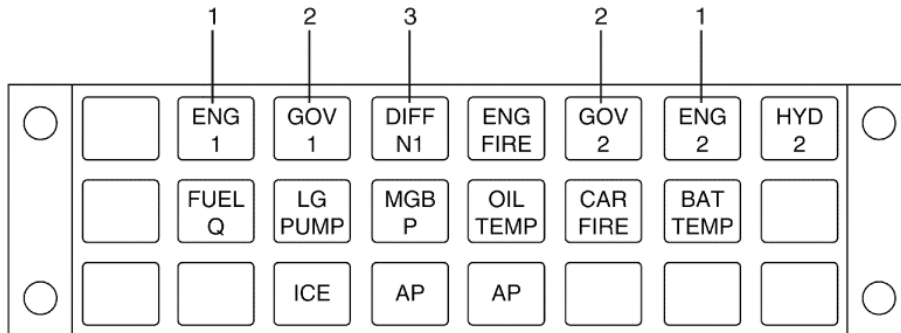

Warning Lights of the Central Warning Panel

Figure 008

3. FAILURES OBSERVED DURING USE

The 3rd section of this manual gives the failures observed during use.

These are the failures detected by the flight crew. These failures either correspond to a flight incident without indication to the cockpit (surge for example), or an indication to the CPDS or to the showing an exceedance of the flight parameters (exceedance of N2 limitations for example) or an anomaly indicated by the control systems (lighting up of the magnetic plug warning light for example).

The contents are divided up as follows:

1. Operation phase: power up, start, operation, shutdown.
2. Identification of the helicopter indication means: CDS, engine indicating instruments (see general).
3. Failure designation.
4. Task number of the trouble shooting procedure corresponding to the last section of the manual.

Example :

A. At power up (a)

<i>INDICATION (b)</i>		<i>DESCRIPTION (c)</i>	<i>TASK No.(d)</i>
<i>VEMD</i>	<i>Warning lights</i>		
	Fuel tank	Pre-blockage signal of the fuel filtering element	71-00-06-811-801

4. FAILURES OBSERVED DURING MAINTENANCE

The 4th section of this manual gives the failures observed during maintenance.

The maintenance personnel detects them after periodic inspection or after a test procedure.

The contents includes:

1. Failure designation
2. Task number of the related trouble shooting procedure in the last section of the manual.

Example:

<i>DESIGNATION (a)</i>	<i>TASK No.(b)</i>
Exhaust fumes	71-00-06-816-801

5. VEMD FAILURE CODES

The 5th section of this manual gives the VEMD failure messages pertaining to the engine.

The VEMD has a maintenance aid to help with trouble shooting.

The VEMD displays the failures indicated by the EECU.

A. Failures indicated by the EECU: Operational mode, System Status page

Refer to Figure 009

The failures are displayed in flight when they are detected. During engine shutdown, there is no recording.

The failures detected by the EECU are transmitted to the VEMD which displays them on the System Status page, "FAIL" line. These are simple failure messages.

This display is alphanumeric.

Example of failure word:

- W/DOG.A,
- ALTER.B.

To this indication is linked the lighting up of a GOV warning light which shows the effect of the failure on the EECU operation.

If a failure affects the main control law, the system uses the back-up law.

The main functions (N1 and N2 regulation, acceleration and deceleration control) are still ensured.

If a failure affects at the same time the main control law and the back-up law, the system changes the channel automatically.

If one or several failures affect the main regulation law and the back-up law of each channel, the system can no longer regulate and automatically freezes the stepper motor.

For each input signal, the EECU uses the criteria to make a decision on the validity signal.

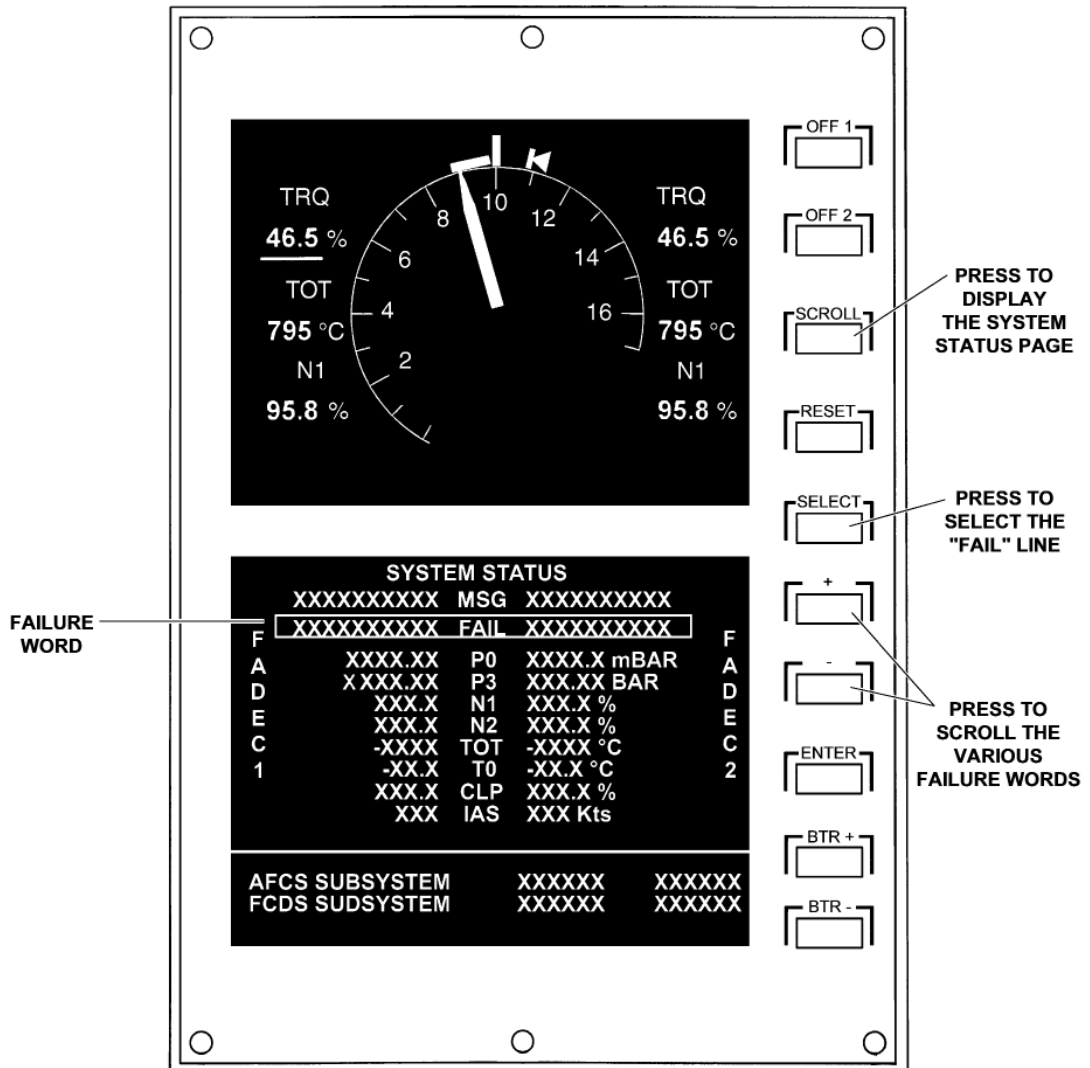

Operational mode - In flight

Figure 009

Three levels are indicated: Refer to Figure 010

- Level 3: Major failure (stepper motor frozen)
- Level 2: Minor failure (the system operation is degraded but the main functions are still ensured)
- Level 1: Minor anomaly (loss of redundancy or of a related function and no effect on the engine operation).

Two warning lights indicate the failures: Red GOV and Amber GOV

- A red GOV light indicates the total failure of the regulation system
- An amber GOV light indicates the degraded operation of the regulation system. If this light flashes at starting, idle or shutdown, it also indicates a minor failure.

NOTE: *The letter at the end of a failure word (A or B) corresponds to channel A or channel B of the EECU.
The architecture of the EECU is of the double channel type. The system includes two channels (channel A and channel B).
Each channel monitors all the data resources to which it gets access and provides information on its ability to ensure engine control.
According to the information supplied by both channels, the selection logic gives the control to the preferential channel if both channels are able to regulate the engine, gives the control to the channel able to regulate if only one channel is able to regulate, freezes the fuel flow if both channels cannot regulate;
During normal operation, channel A is the preferential channel, i.e. in control. Channel B is the pending channel.
For the VEMD failure messages, the trouble shooting processing is based on an operation with the preferential channel A.*

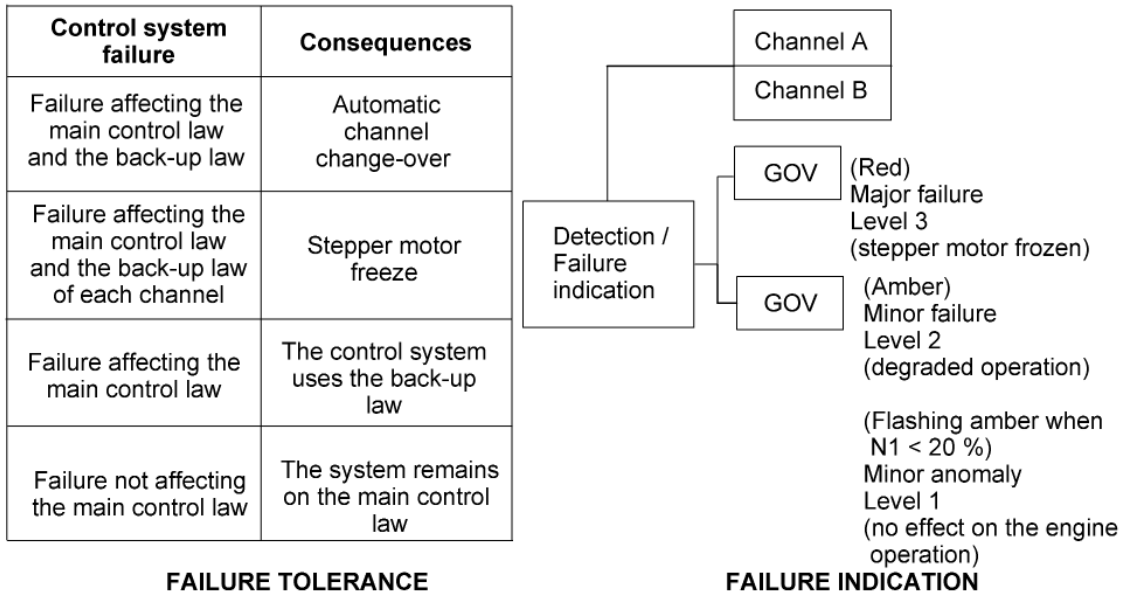

Tolerance and failure indication

Figure 010

B. Contents of the failure messages in the operational mode, Status System page

CAUTION: FOR THE VEMD FAILURE MESSAGES, THE PROCESSING OF THE TROUBLE SHOOTING IS BASED ON AN OPERATION WITH THE PREFERENTIAL CHANNEL A.

The contents includes:

1. The identification of the helicopter indication means: VEMD failure word and related GOV warning light.
2. The failure designation.
3. The task number of the related trouble shooting procedure in the last section of the manual.

INDICATION (a)		DESIGNATION (b)	TASK No. (c)
VEMD codes	GOV warning light		
W/DOG. A	Flashing amber	Watchdog trip	71-00-06-817-801

6. TROUBLE SHOOTING

The 6th section of this manual gives, in the form of trouble shooting, the tasks from the contents.

The descriptive part of the trouble shooting procedure is function of:

- The helicopter indication means: CWP, CPDS
- The operation phase, power up, starting, operation, shutdown for the failures observed during use
- The reference to the check, inspection or test tasks for the failures observed during maintenance
- The failure effects on the engine use for VEMD failure messages
- A reminder of the normal operating condition
- The components list.

The failure handling, in the form of a tree, is done by comparing the reliability data, accessibility criteria and complexity of check or test tasks of the applicable components.

NOTE: *The trouble shooting given in this manual only concern the engine part of the applicable systems.*

NOTE: *Before you start the trouble shooting, make sure that all the checks and instructions have been applied.*

NOTE: *Before you start the trouble shooting, make sure that all the procedures described in the flight manual are correctly applied.*

NOTE: *Before you start the trouble shooting, make sure that the warning light or indicator is serviceable before you make a decision on the failure of the related system.*

7. TASK NUMBERING

The standardized numbering of the task is an extension of the three-digit A.T.A. system.

In this chapter, the numbering system has 5 groups of characters.

Example:

Task No.	71	00	06	811	801
Group	1	2	3	4	5

A. The group 1, 2, 3 gives the chapter, section, subject:

71 : turboshaft engine

00 : general

06 : subject order

B. The group 4 gives the type of maintenance function

The first two digit 81 are the code number of the maintenance program (trouble shooting).

The third digit in this group gives the engine operating phase when the failure is detected or its detection mode:

1 : Power on

2 : Start

3 : Transient rating

4 : During operation

6 : Check and inspection

7 : Failure message

C. The group 5 gives, to each group 4, a serial number from 801

PAGE LEFT BLANK INTENTIONALLY

FAILURES FOUND DURING OPERATION

CAUTION: BEFORE THE REMOVAL OF THE ENGINE FROM THE AIRFRAME,
(REFER TO TASK 71-02-16-280-801) "TREATMENT OF AN ENGINE/MODULE BEFORE
RETURN TO A MAINTENANCE CENTER".

1. LIST

A. At power up

<i>Indication</i>		<i>Failure identification</i>	<i>Task No.</i>
<i>Alarms VEMD</i>	<i>Warning indicator lights</i>		
	Fuel tank	Pre-blockage signal of the fuel filtering element	71-00-06-811-801
	Fuel tank	No low fuel pressure signal	71-00-06-811-802
	Red ENG 1 or ENG 2 off	No low oil pressure signal	71-00-06-811-803
	Red GOV Amber GOV Flashing amber GOV	Lighting up of the GOV warning light	71-00-06-811-804
	FADEC and GOV not lit	No illumination of FADEC and GOV lights during EECU self test	71-00-06-811-806
	Red Gov	Lighting up of the GOV warning light	71-00-06-811-808

B. At starting

<i>Indication</i>		<i>Failure identification</i>	<i>Task No.</i>
<i>Alarms VEMD</i>	<i>Warning indicator lights</i>		
	Fuel tank	No extinguishing of the low fuel pressure signal	71-00-06-812-802
Red flash under TOT and Over Limit detected		T4.5 overtemperature	71-00-06-812-804
		Gas generator not driven	71-00-06-812-805
	Red ENG 1 or ENG 2 on	No extinguishing of the low oil pressure signal	71-00-06-812-806
		Aborted start - No ignition	71-00-06-812-807
		Aborted start - Flame out	71-00-06-812-810
		Aborted start - Flames at the exhaust pipe	71-00-06-812-812

List of failures observed during engine operation

71-00-06

Page 101
Dec. 30/2021

<i>Indication</i>		<i>Failure indentification</i>	<i>Task No.</i>
<i>Alarms VEMD</i>	<i>Warning indicator lights</i>		
		No oil pressure rise at starting	71-00-06-812-813
		Helicopter rotor movement that occurs after the usual time during engine start	71-00-06-812-816

C. Engine running

<i>Indication</i>		<i>Failure indentification</i>	<i>Task No.</i>
<i>Alarms VEMD</i>	<i>Warning indicator lights</i>		
		Surge	71-00-06-813-801
	ENG CHIP on	Indicator light of the electrical magnetic plug on	71-00-06-814-801
	Fuel tank	Pre-blockage signal of the fuel filtering element	71-00-06-814-802
	Fuel tank	Low fuel pressure signal	71-00-06-814-803
Red flash under TRQ and Over Limit detected		Torque limitations exceeded	71-00-06-814-805
Red flash under N1 and Over Limit detected		N1 limitations exceeded	71-00-06-814-806
Over Limit detected	NR/2 NTL indicator	N2 limitations exceeded	71-00-06-814-807
ENGINE OIL PRESSURE indicator		Abnormal evolution of the oil pressure	71-00-06-814-808
	Red ENG 1 or ENG 2 on	Low oil pressure signal	71-00-06-814-809
Red line under ENGINE OIL TEMPERATURE		Oil overtemperature	71-00-06-814-810

D. Engine shutdown

<i>Indication</i>		<i>Failure indentification</i>	<i>Task No.</i>
<i>Alarms VEMD</i>	<i>Warning indicator lights</i>		
		Abnormal noise during the rundown phase	71-00-06-815-801
		Rundown time less than 25s	71-00-06-815-802
	Fuel tank	No low fuel pressure signal	71-00-06-815-804

<i>Indication</i>		<i>Failure indentification</i>	<i>Task No.</i>
<i>Alarms VEMD</i>	<i>Warning indicator lights</i>		
	Red ENG 1 or ENG 2 off	No low oil pressure signal	71-00-06-815-805
		Power turbine blocked	71-00-06-815-806

PAGE LEFT BLANK INTENTIONALLY

LIST OF FAILURES FOUND DURING MAINTENANCE

CAUTION: BEFORE THE REMOVAL OF THE ENGINE FROM THE AIRFRAME,
(REFER TO TASK 71-02-16-280-801) "TREATMENT OF AN ENGINE/MODULE BEFORE
RETURN TO A MAINTENANCE CENTER".

1. **LIST**

A. Failures observed during maintenance

<i>DESIGNATION</i>	<i>TASK No.</i>
Unusual noise during the rundown phase	71-00-06-815-801
Rundown time out of limit	71-00-06-815-802
Fumes at the exhaust pipe	71-00-06-816-801
Particles in the oil filtering element	71-00-06-816-803
Oil or fuel leakage	71-00-06-816-804
Out of tolerance fuel flow at the tank return pipe	71-00-06-816-805
Fuel filter clogging indicator popped out	71-00-06-816-806
Fuel dilution rate in oil not compliant	71-00-06-816-807
Incorrect operation of one of the ignition device lines	71-00-06-816-808
Bleed valve anomaly observed	71-00-06-817-884
Particles on a magnetic plug	71-00-06-816-810
Non conform oil consumption	71-00-06-816-811
Check of abnormal oil pressure	71-00-06-816-812
Popping out of the pre-blockage visual indicator of the oil filter	71-00-06-816-813
Oil leakage between M03 and M04	71-00-06-816-814
Vibration out of tolerance detected by the M'ARMS system	71-00-06-816-815
Engine power check - incorrect margin	71-00-06-816-819
Fuel odor in the cabin	71-00-06-816-821
Oil tank level slowly decreases after engine shut-down	71-00-06-816-833

PAGE LEFT BLANK INTENTIONALLY

LIST OF FAILURES CODES

1. LIST OF VEMD FAILURE CODES

A. Operational mode, System Status page

<i>Indication</i>		<i>Failure indentification</i>	<i>Task No.</i>
<i>Alarms VEMD</i>	<i>Warning indicator lights</i>		
W/DOG. A	Flashing amber	Watchdog trip	71-00-06-817-801
W/DOG. B	Red / Flashing amber	Watchdog trip	71-00-06-817-801
T/SEL. A	Flashing amber	TNG selector failure	71-00-06-817-805
T/SEL. B	Flashing amber	TNG selector failure	71-00-06-817-805
SELECT. A	Amber / Flashing amber	OFF/IDLE/FLIGHT selector failure	71-00-06-817-808
SELECT. B	Red / Flashing amber	OFF/IDLE/FLIGHT selector failure	71-00-06-817-808
T0.DISC. A	Flashing amber	T1 inconsistency	71-00-06-817-810
PITCH. A	Flashing amber	Collective pitch failure	71-00-06-817-823
PITCH. B	Amber / Flashing amber	Collective pitch failure	71-00-06-817-823
TOT. A	Amber / Flashing amber	Raw t4.5 failure	71-00-06-817-825
TOT. B	Amber / Flashing amber	Raw t4.5 failiure	71-00-06-817-825
T1. A	Amber / Flashing amber	T1 failure (T0 Engine)	71-00-06-817-828
T1. B	Amber / Flashing amber	T1 failure (T0 Engine)	71-00-06-817-828
P3. A	Amber	P3 failure	71-00-06-817-833
P3. B	Amber / Flashing amber	P3 failure	71-00-06-817-833
TRQ. A	Amber	Raw torque failure	71-00-06-817-842
TRQ. B	Amber / Flashing amber	Raw torque failure	71-00-06-817-842
TOT M. A	Amber / Flashing amber	T4.5 conformation failure	71-00-06-817-844
TOT M. B	Amber / Flashing amber	T4.5 conformation failure	71-00-06-817-844
TRQ CL. A	Amber	Torque conformation failure	71-00-06-817-847
TRQ CL. B	Amber / Flashing amber	Torque conformation failure	71-00-06-817-847
TRIM.POS. A	Amber	N2 TRIM position failure	71-00-06-817-803
TRIM.POS. B	Amber	N2 TRIM position failure	71-00-06-817-804
A/B RE. A	Flashing amber	Interchannel reception failure	71-00-06-817-910

TURBOMECA ARRIEL 2 C1

MAINTENANCE MANUAL

<i>Indication</i>		<i>Failure identification</i>	<i>Task No.</i>
<i>Alarms VEMD</i>	<i>Warning indicator lights</i>		
A/B RE. B	Amber	Interchannel reception failure	71-00-06-817-910
PROCES. A	Flashing amber	DECU internal failure	71-00-06-817-861
PROCES. B	Flashing amber	DECU internal failure	71-00-06-817-861
P3/FLA. A	Amber	P3 drift or flame-out	71-00-06-817-864
P3/FLA. B	Amber / Flashing amber	P3 drift or flame-out	71-00-06-817-864
P0. A	Flashing amber	Engine P0 failure	71-00-06-817-869
P0. B	Amber / Flashing amber	Engine P0 failure	71-00-06-817-869
RESOL. A	Amber / Flashing amber	Fuel valve resolver failure	71-00-06-817-878
RESOL. B	Red / Amber / Flashing amber	Fuel valve resolver failure	71-00-06-817-878
STEP M. A	Flashing amber	Stepper motor failure	71-00-06-817-880
STEP M. B	Flashing amber	Stepper motor failure	71-00-06-817-881
STEP M. A and STEP M. B	Red	Stepper motor failure	71-00-06-817-882
BV. A	Amber	Bleed valve failure	71-00-06-817-884
BV. B	Amber	Bleed valve failure	71-00-06-817-884
BALAN. A	Amber	Balance link failure (ARINC 429)	71-00-06-817-890
H TOT. A	Flashing amber	Helicopter t4.5 failure	71-00-06-817-889
NR. A	Flashing amber	NR failure	71-00-06-817-905
NF. A	Flashing amber	N2 failure (C/harness)	71-00-06-817-913
NF. B	Red / Flashing amber	N2 failure (B/harness)	71-00-06-817-907
NG. A	Flashing amber	N1 failure on alternator electrical connector (alternateur A/alternator A on the harness)	71-00-06-817-918
NG. B	Flashing amber	N1 failure on alternator electrical connector (alternateur B/alternator B on the harness)	71-00-06-817-919
NG. A and NG. B	Red	N1 failure on alternator electrical connector (alternateur A/alternator A and alternateur B/alternator B on the harness)	71-00-06-817-920
H P0. A	Amber / Flashing amber	Helicopter P0 failure	71-00-06-817-928

List of failure codes

Page 102

Nov. 30/2012

TURBOMECA ARRIEL 2 C1

MAINTENANCE MANUAL

<i>Indication</i>		<i>Failure identification</i>	<i>Task No.</i>
<i>Alarms VEMD</i>	<i>Warning indicator lights</i>		
H LINK. A	Amber	No helicopter ARINC	71-00-06-817-929
ALTER. A	Flashing amber	Alternator failure channel A	71-00-06-817-932
ALTER. B	Flashing amber	Alternator failure channel B	71-00-06-817-933
ALTER. A and ALTER. B	Red	Alternator failure	71-00-06-817-931
28V. A	Amber / Flashing amber	28 V failure channel A	71-00-06-817-938
28V. B	Amber / Flashing amber	28 V failure channel B	71-00-06-817-939
P0 MIS. A	Amber / Flashing amber	P0 inconsistency	71-00-06-817-948
EL.V. A	Amber	Stop electrovalve failure	71-00-06-817-949
EL.V. B	Amber / Flashing amber	Stop electrovalve failure	71-00-06-817-949
SOFT. A	Flashing amber	Real time software failure	71-00-06-817-959
SOFT. B	Red / Flashing amber	Real time software failure	71-00-06-817-959
OV/SP. A	Flashing amber	Overspeed protection failure	71-00-06-817-955

PAGE LEFT BLANK INTENTIONALLY

TASK 71-00-06-811-801-A01

FUEL FILT ON - PRE-BLOCKAGE SIGNAL OF THE FUEL FILTERING ELEMENT TROUBLESHOOTING

1. GENERAL

A. PHASE AND FAILURE DETECTION

<i>Phase</i>	<i>Indication</i>	
	<i>Alarms VEMD</i>	<i>Warning lights</i>
AT POWER UP		Fuel tank

B. REMINDER OF THE NORMAL OPERATING CONDITION

At power up, the pre-blockage signal of the fuel filtering element must remain off.

C. POSSIBLE CAUSES

- Pre-blockage pressure switch of the fuel filter
- Control and monitoring harness
- Aircraft

2. PROCEDURE

TURBOMECA ARRIEL 2 C1

MAINTENANCE MANUAL

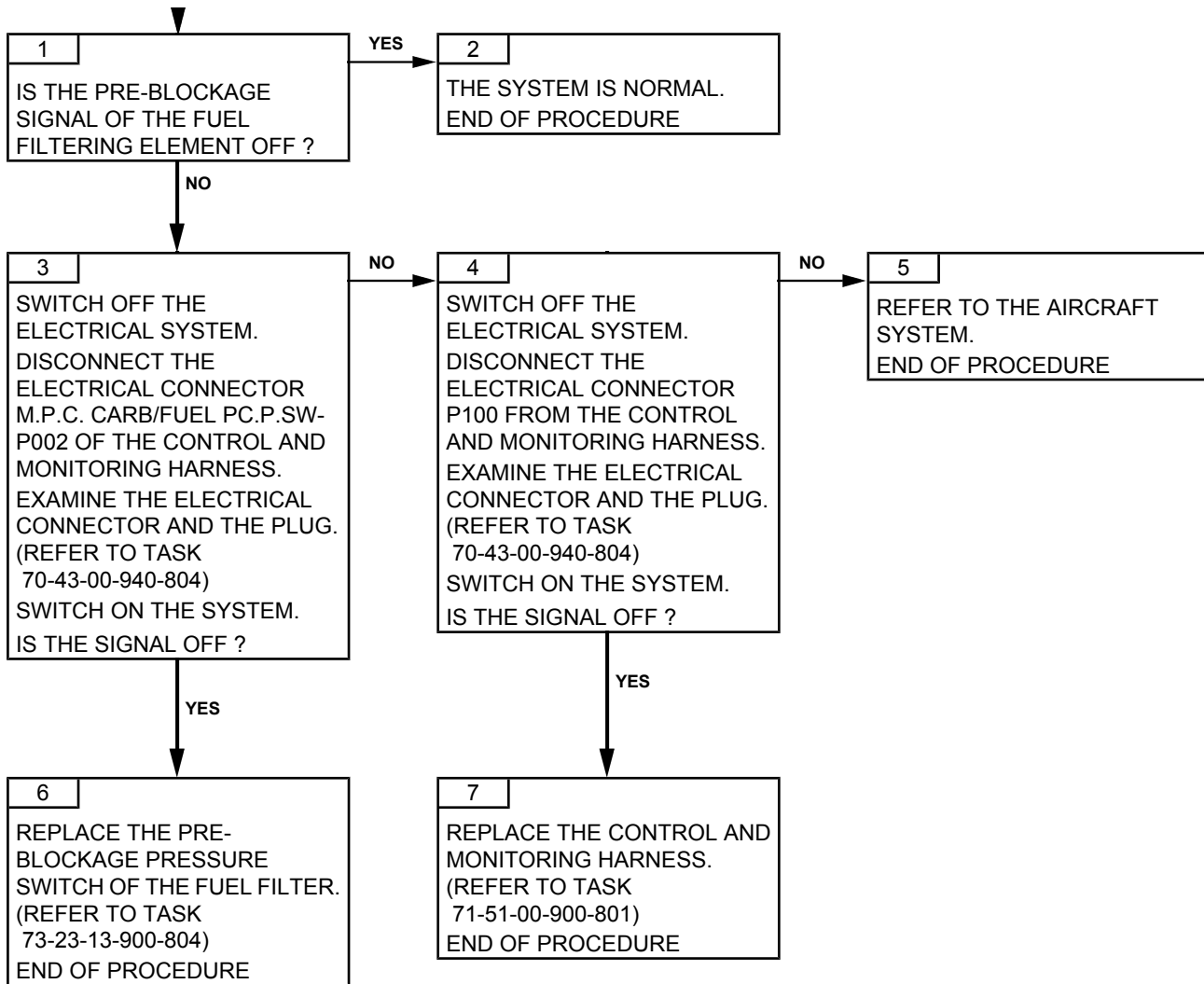

Effectivity: C1

Failures observed during engine operation

TASK 71-00-06-811-802-A01

FUEL P OFF - NO LOW FUEL PRESSURE SIGNAL TROUBLESHOOTING

1. GENERAL

A. PHASE AND FAILURE DETECTION

<i>Phase</i>	<i>Indication</i>	
	<i>Alarms VEMD</i>	<i>Warning lights</i>
AT POWER UP		Fuel tank

B. REMINDER OF THE NORMAL OPERATING CONDITION

At power up, the low fuel pressure signal must be on.

C. POSSIBLE CAUSES

- Low-fuel pressure switch
- Control and monitoring harness
- Aircraft

2. PROCEDURE

TURBOMECA ARRIEL 2 C1

MAINTENANCE MANUAL

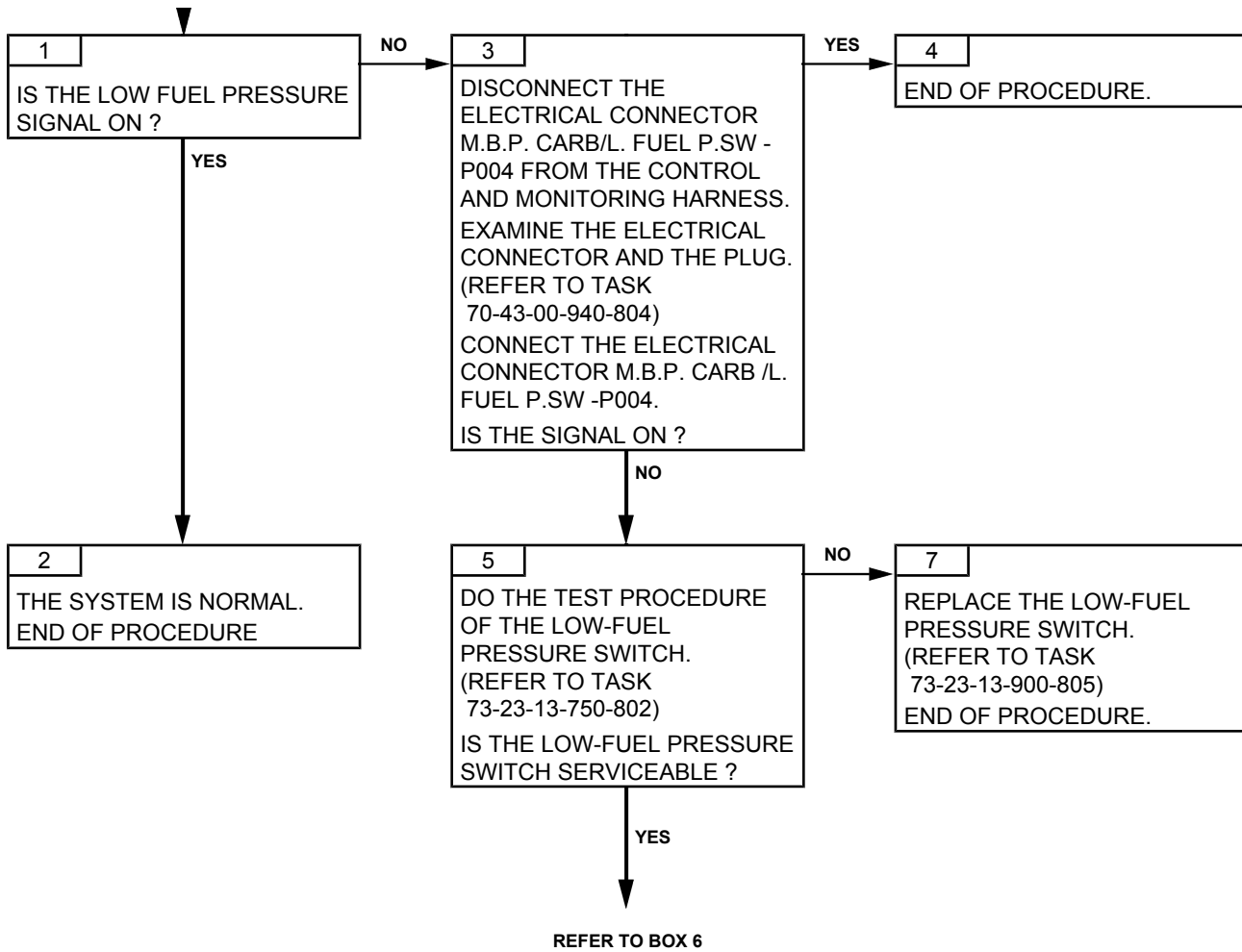

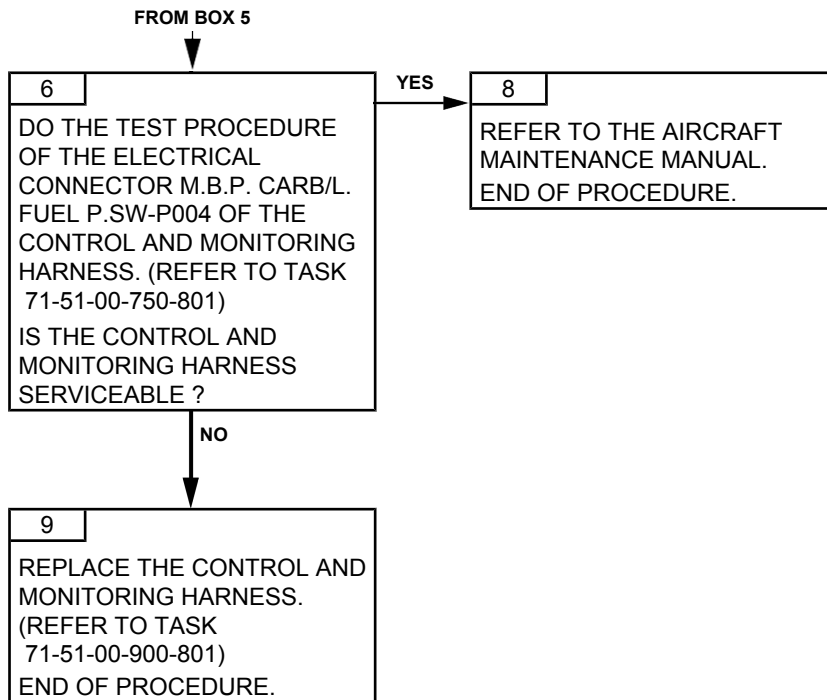

PAGE LEFT BLANK INTENTIONALLY

TASK 71-00-06-811-803-A01

ENG P OFF - NO LOW OIL PRESSURE SIGNAL TROUBLESHOOTING

1. GENERAL

A. PHASE AND FAILURE DETECTION

<i>Phase</i>	<i>Indication</i>	
	<i>Alarms VEMD</i>	<i>Warning indicator lights</i>
AT POWER UP		Red ENG 1 or ENG 2 off

B. REMINDER OF THE NORMAL OPERATING CONDITION

At power up, the red ENG 1 or ENG 2 warning light must be on.

C. POSSIBLE CAUSES

- Low-oil pressure switch
- Control and monitoring harness
- Aircraft

2. PROCEDURE

TURBOMECA ARRIEL 2 C1

MAINTENANCE MANUAL

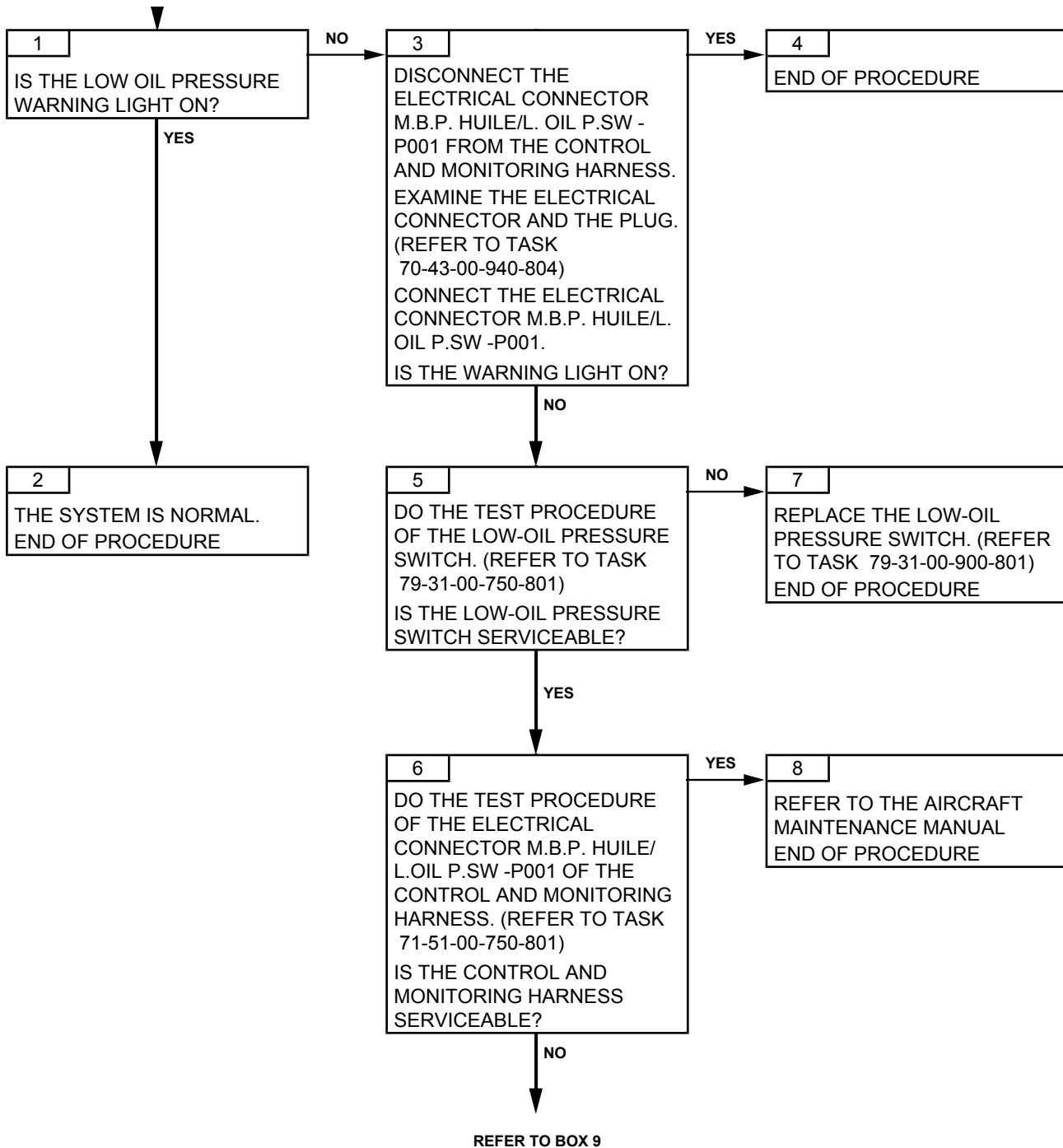

Effectivity: C1

Failures observed during engine operation

FROM BOX 6



9

REPLACE THE CONTROL AND
MONITORING HARNESS.
(REFER TO TASK
71-51-00-900-801)
END OF PROCEDURE

PAGE LEFT BLANK INTENTIONALLY

TASK 71-00-06-811-804-A01

RED GOV OR AMBER GOV OR FLASHING GOV ON - LIGHTING OF GOV WARNING LIGHT TROUBLESHOOTING

1. GENERAL

A. PHASE AND FAILURE DETECTION

<i>Phase</i>	<i>Indication</i>	
	<i>Alarms VEMD</i>	<i>Warning indicator lights</i>
AT POWER UP		Red, amber and flashing amber GOV warning light

B. REMINDER OF THE NORMAL OPERATING CONDITION

At power up, the GOV warning lights must be off.

C. POSSIBLE CAUSES

- Failures detected by the EECU

2. PROCEDURE

▼
1

LOOK FOR THE FAILURE CODE CORRESPONDING TO THE LIGHTING UP OF A GOV WARNING LIGHT IN THE OPERATIONAL MODE, SYSTEM STATUS PAGE. REFER TO THE LIST OF VEMD FAILURE CODES IN THIS MANUAL TO DO THE RELATED TASK.

ARRIEL 2 C1

TASK 71-00-06-811-806-A01

**NO ILLUMINATION OF FADEC AND GOV LIGHTS
DURING EECU SELF TEST
TROUBLESHOOTING****1. GENERAL****A. PHASE AND FAILURE DETECTION**

<i>Phase</i>	<i>Indication</i>	
	<i>Alarms on the VEMD</i>	<i>CAD MESSAGE</i>
AT POWER UP		FADEC and GOV not lit

B. REMINDER OF THE NORMAL OPERATING CONDITION

At EECU Power ON, during the EECU self-test, the EECU powers the following warning lights: GOV, FADEC. At the end of the EECU self-test, the warning lights GOV and FADEC are extinguished.

C. POSSIBLE CAUSES

- EECU
- 28V supply to the EECU (Aircraft side)

2. PROCEDURE

NOTE: *The EECU has three power supplies: one dedicated to channel A, one dedicated to channel B and one dedicated to EECU discrete outputs (which includes the GOV and FADEC lights).*

The power supply interfaces at the EECU are:

- *Discrete outputs: connector P4 pins 2 (+) and 3 (-)*
- *Channel A: connector P2 pins 54 (+) and 55 (-)*
- *Channel B: connector P4 pins 63 (+) and 62 (-).*

With battery power ON, +28 Vdc power supply should always be present at these interfaces.

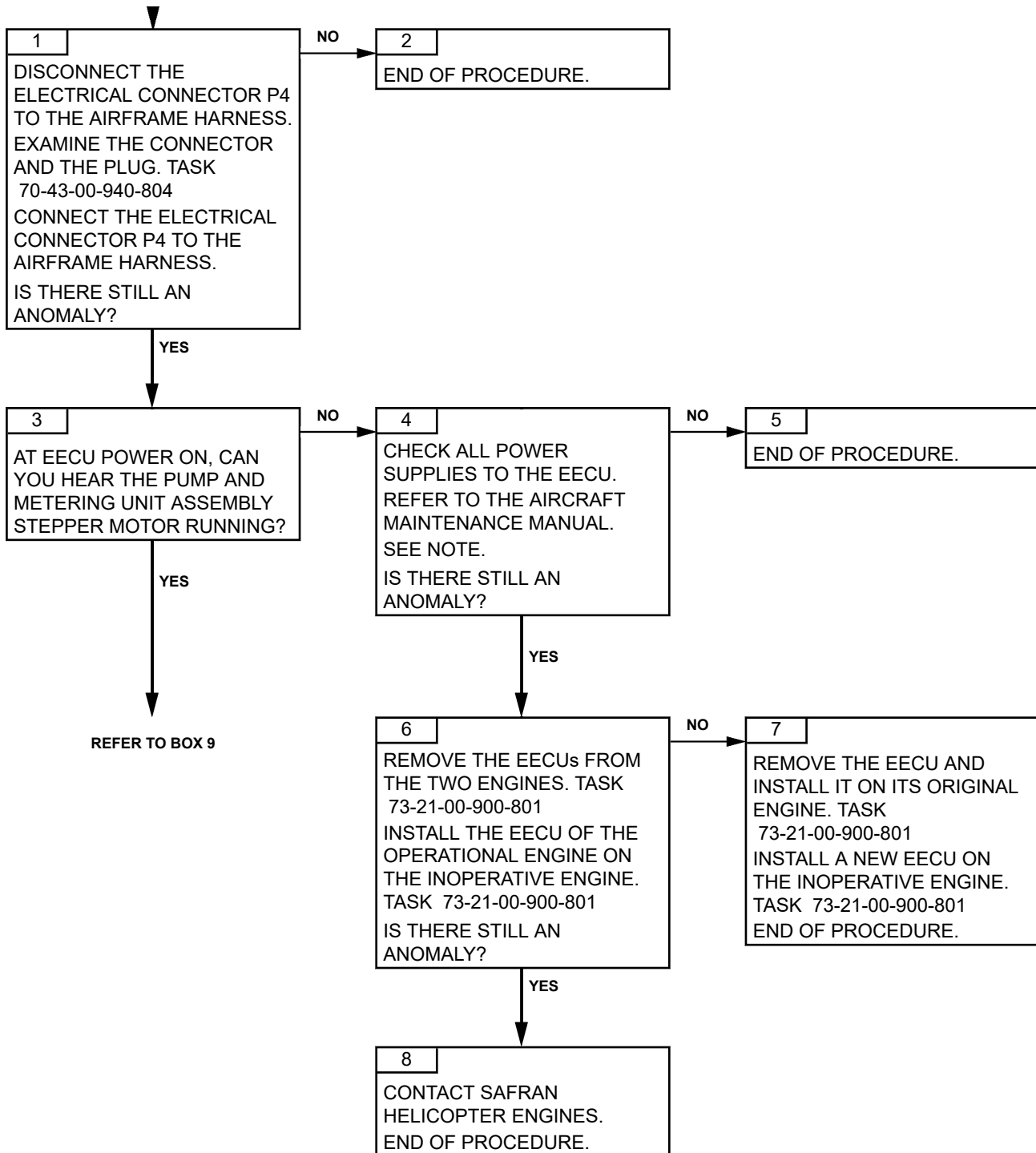

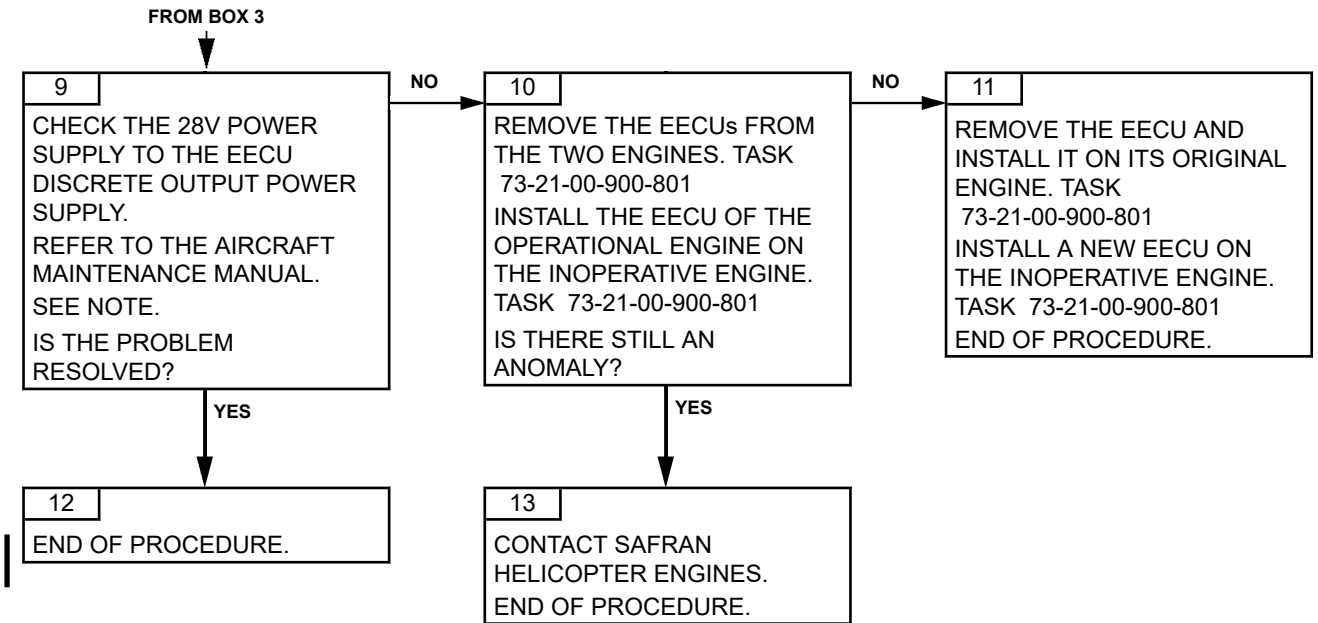

PAGE LEFT BLANK INTENTIONALLY

TASK 71-00-06-811-808-A01

**RED GOV AT POWER ON
TROUBLESHOOTING****1. GENERALITY****A. PHASE AND FAILURE DETECTION**

<i>Phase</i>	<i>Indication</i>	
	<i>Alarms VEMD</i>	<i>Warning indicator lights</i>
POWER ON		RED GOV

B. REMINDER OF THE OPERATING NORMAL CONDITION OR FAILURE DETECTION

At power on, the EECU switches off the RED GOV warning light and performs its power on built in tests.

The RED GOV light remains activated at power on when either the EECU is not correctly supplied or EECU starting selector input is different from STOP.

C. POSSIBLE CAUSES

- AIRCRAFT
- EECU

2. PROCEDURE

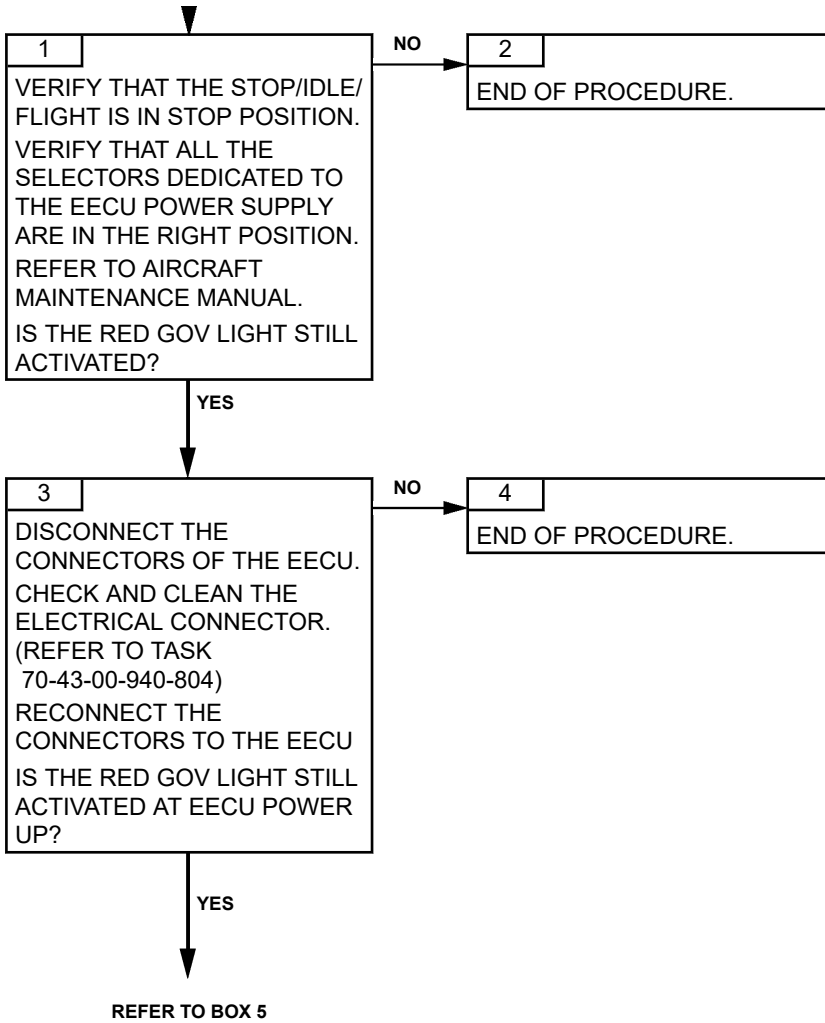

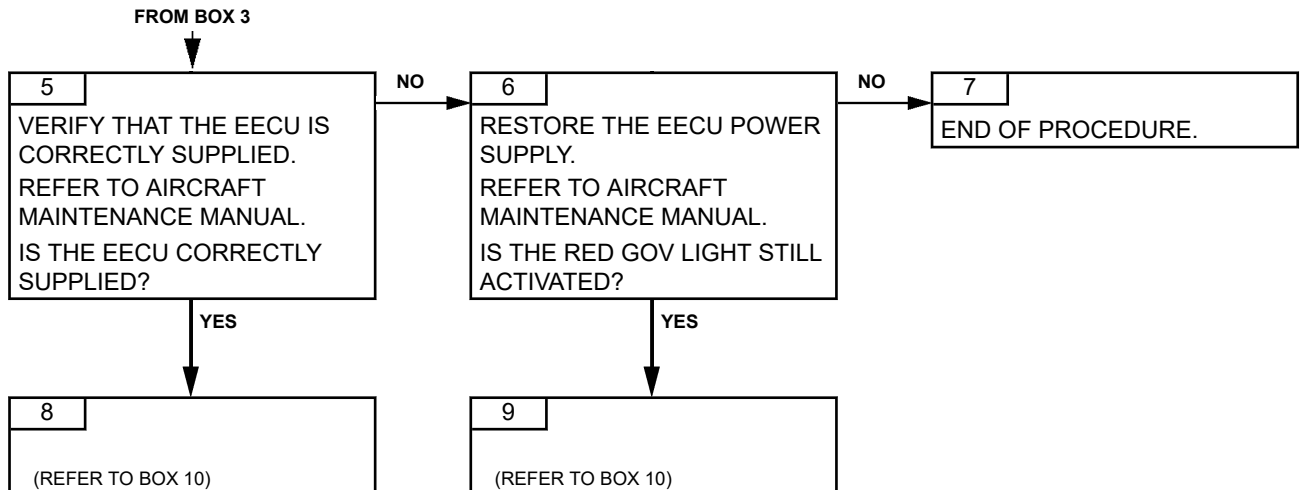

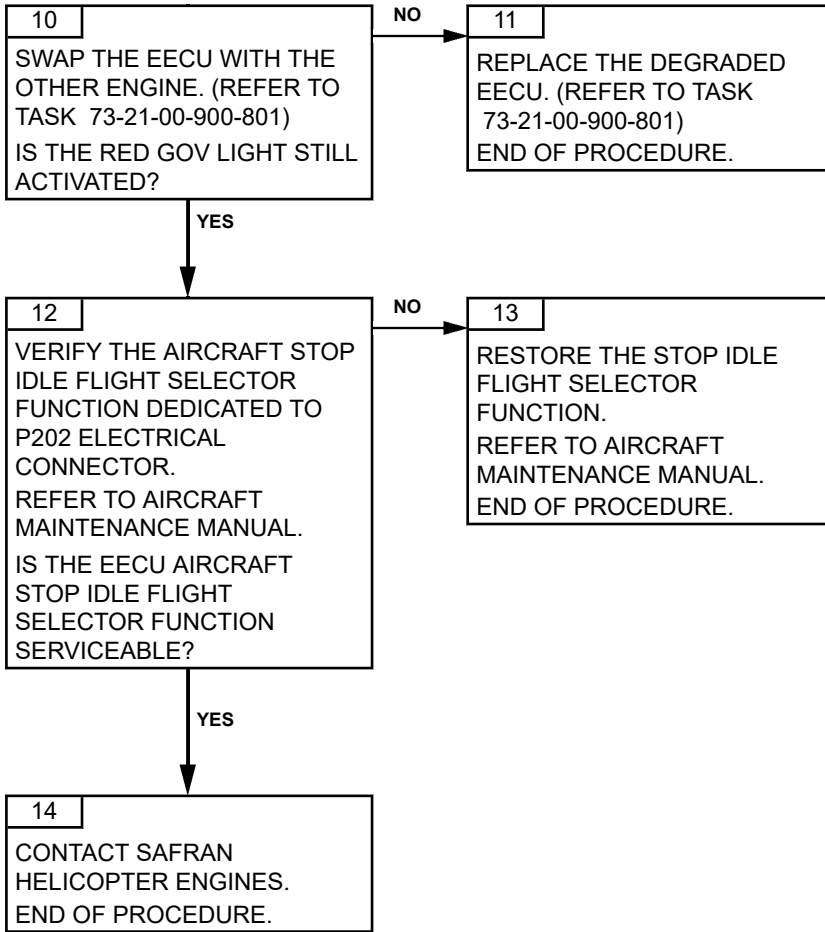

TASK 71-00-06-812-802-A01

FUEL P ON - NO EXTINGUISHING OF THE LOW FUEL PRESSURE SIGNAL TROUBLESHOOTING

1. GENERAL

A. PHASE AND FAILURE DETECTION

<i>Phase</i>	<i>Indication</i>	
	<i>Alarms VEMD</i>	<i>Warning lights</i>
AT STARTING		Fuel tank

B. REMINDER OF THE NORMAL OPERATING CONDITION

The start is normal and the low fuel pressure signal is off at ground idle.

C. POSSIBLE CAUSES

- Low-fuel pressure switch
- Control and monitoring harness
- Aircraft

2. PROCEDURE

TURBOMECA ARRIEL 2 C1

MAINTENANCE MANUAL

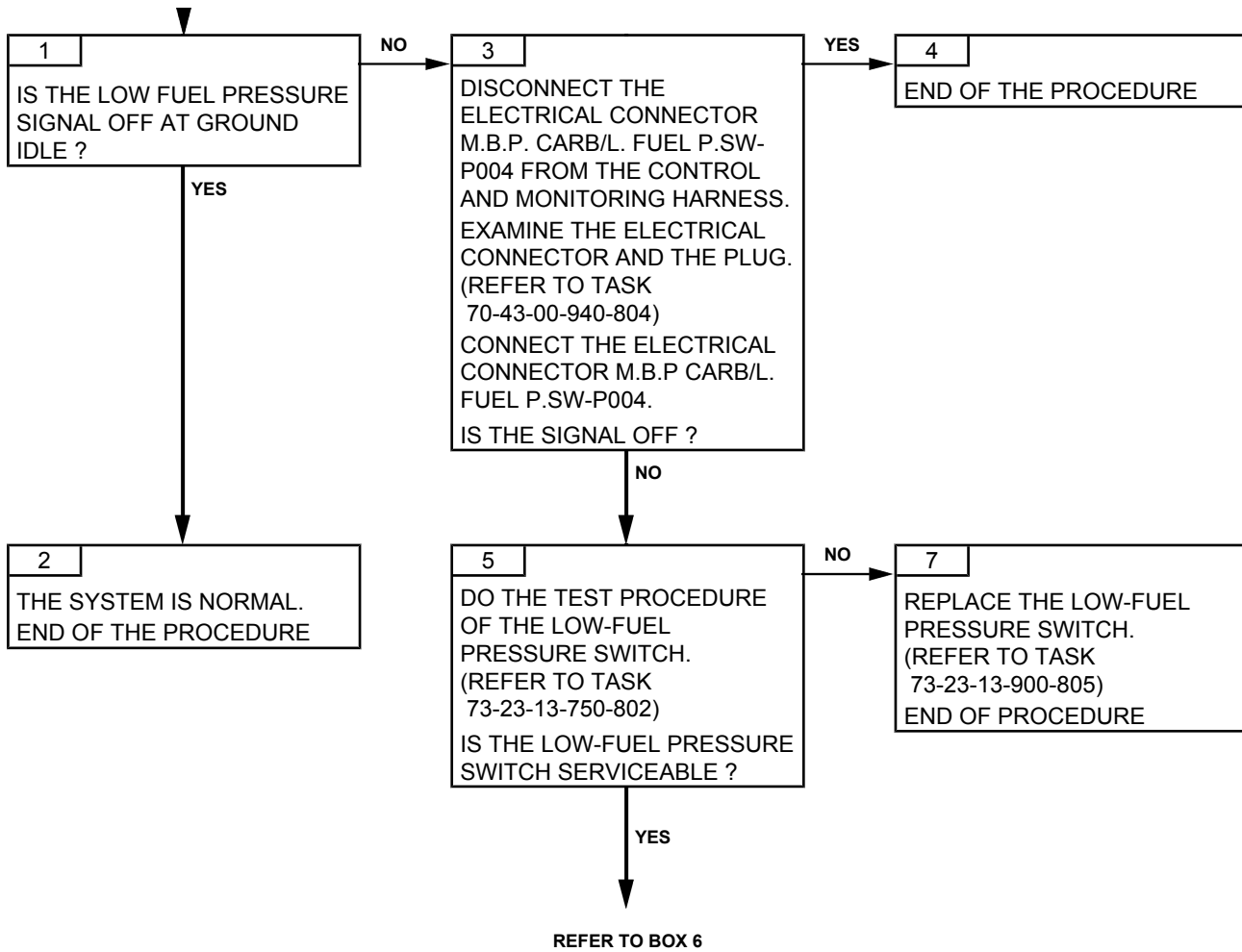

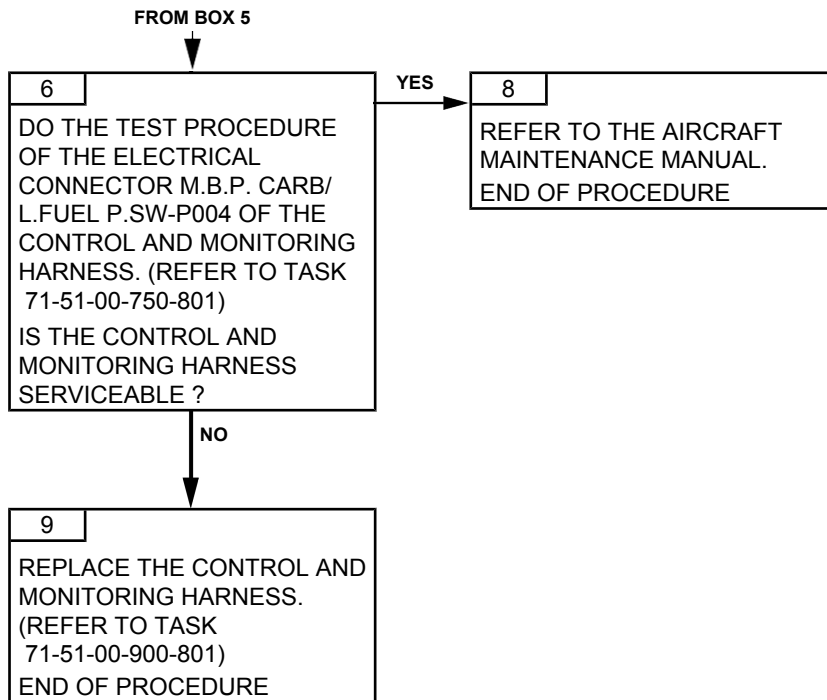

PAGE LEFT BLANK INTENTIONALLY

TASK 71-00-06-812-804-A01

ENGINE PARAMETER OUT OF LIMIT - T4.5 LIMITATIONS EXCEEDED TROUBLESHOOTING

1. GENERAL

A. PHASE AND FAILURE DETECTION

<i>Phase</i>	<i>OTHER AVIONIC INDICATION</i>	
	<i>Alarms VEMD</i>	<i>Warning indicator lights</i>
AT STARTING	Flashing red dash under the indication T45	N/A

<i>Phase</i>	<i>MH65E INDICATION</i>		
	<i>MFD EICAS page</i>	<i>CDU TDL page</i>	<i>ECMS page</i>
AT STARTING	Yellow ENG EXCEED and TOT ZN EXCEED	N/A	ENGINE TOT

B. REMINDER OF THE NORMAL OPERATING CONDITION

T4.5 limitations, (Refer to Task 71-00-01-940-801).

C. POSSIBLE CAUSES

- Pump and metering unit
- T4.5 measurement system
- Drain valve of the turbine casing
- Starter
- Starter power supply

2. PROCEDURE

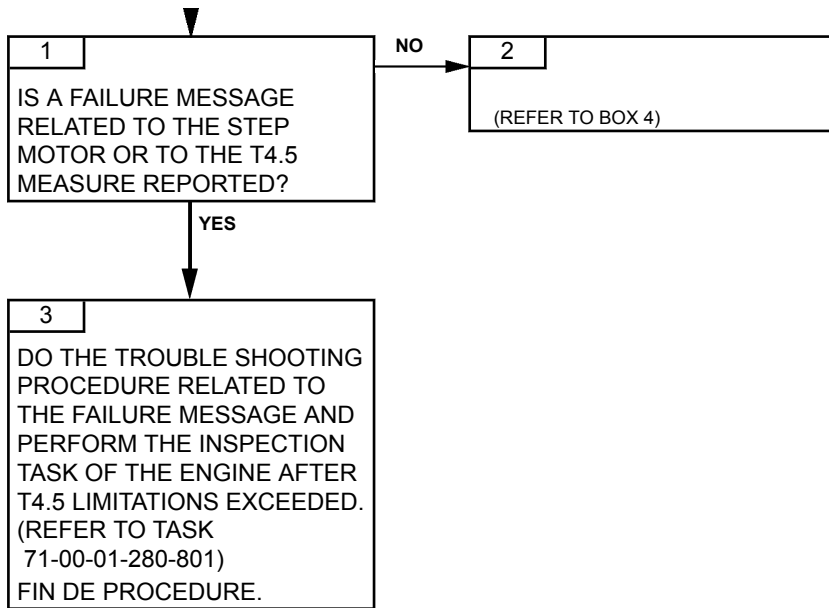

TURBOMECA ARRIEL 2 C1

MAINTENANCE MANUAL

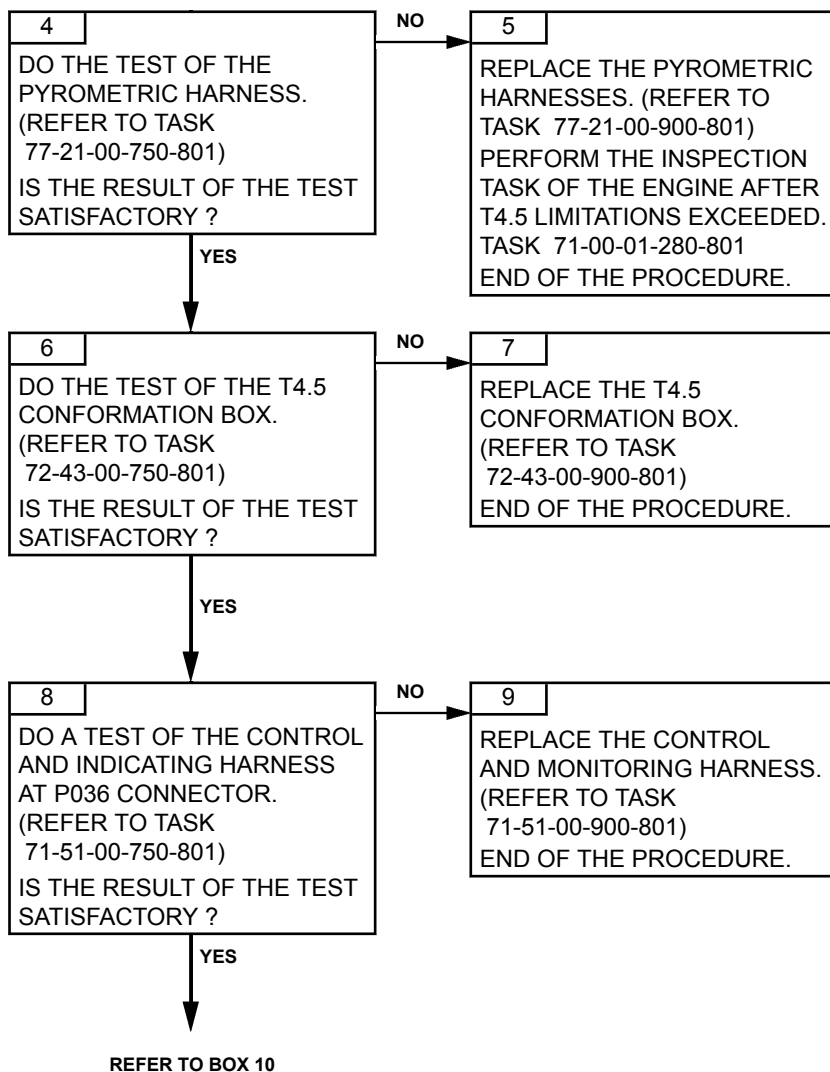

Effectivity: C1

The information in this manual is subject to the warning given on the information page.

71-00-06-812-804-A01

Failures observed during engine operation

Page 103
Nov. 30/2017

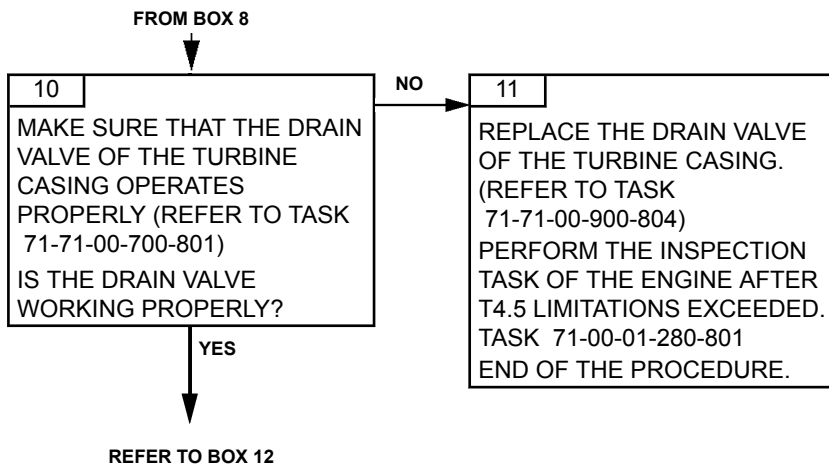

TURBOMECA ARRIEL 2 C1

MAINTENANCE MANUAL

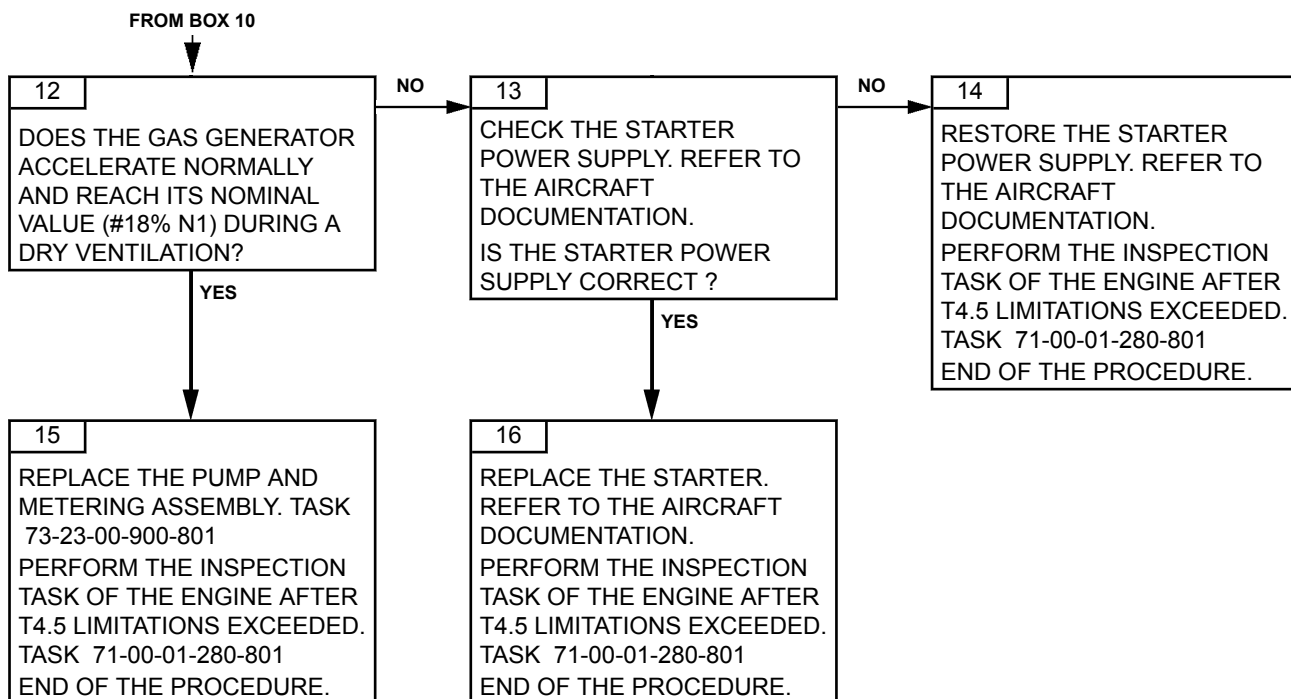

Effectivity: C1

Failures observed during engine operation

71-00-06-812-804-A01

PAGE LEFT BLANK INTENTIONALLY

TASK 71-00-06-812-805-A01

**ABORTED START - GAS GENERATOR NOT DRIVEN
TROUBLESHOOTING****1. GENERAL****A. GENERAL DESCRIPTION**

In the troubleshooting book, there are different troubleshooting tasks concerning aborted start. Titles are:

- **“Aborted start: gas generator not driven”**: Do this troubleshooting task if the gas generator is not driven at all (N1 = 0 %) at the engine start selection or during cranking.
- **“Aborted start: no ignition”**: When the pilot turns the main selector STOP/IDLE/FLIGHT to IDLE or FLIGHT, the EECU launches the starting sequence. At starting, the gas generator is driven but no ignition of the combustion chamber (T4 does not increase).
- **“Aborted start: first start aborted”**: Do this **preventive task** when there are starting difficulties only at the first start of the day, or after the aircraft has been sitting for several hours, i.e. the engine is at ambient temperature.
- **“Aborted start: slow start or stagnation”**: Do this troubleshooting task when the ignition in the combustion chamber is observed, but the N1 speed increases more slowly than usual, or the N1 speed stops increasing during start (and the pilot has to abort manually the starting sequence).
- **“Aborted start: flames at the exhaust pipe”**: Do this troubleshooting task when the starting sequence generates abnormal flames at the exhaust pipe.
- **“Aborted start: flame out”**: Do this troubleshooting task when ignition is observed, the N1 speed increases but the combustion chamber flames out without any action by the pilot.
- **“T4.5 limitations exceeded”**: Do this troubleshooting task when a T4.5 overtemperature is observed during engine running or during starting sequence.

B. POSSIBLE CAUSES

- Starter generator
- Alternator
- Oil pump
- Fuel pump and metering unit
- Module 01 (Transmission shaft and accessory gearbox)
- Module 02 (Axial compressor)
- Module 03 (Gas generator)
- Aircraft

2. PROCEDURE

NOTE: *In case of a recent maintenance operation performed on this engine or on the aircraft starting system (starter, battery, fuse, selector, harness...), check first the sub-assembly concerned by this maintenance operation, in particular the plug and connectors.*

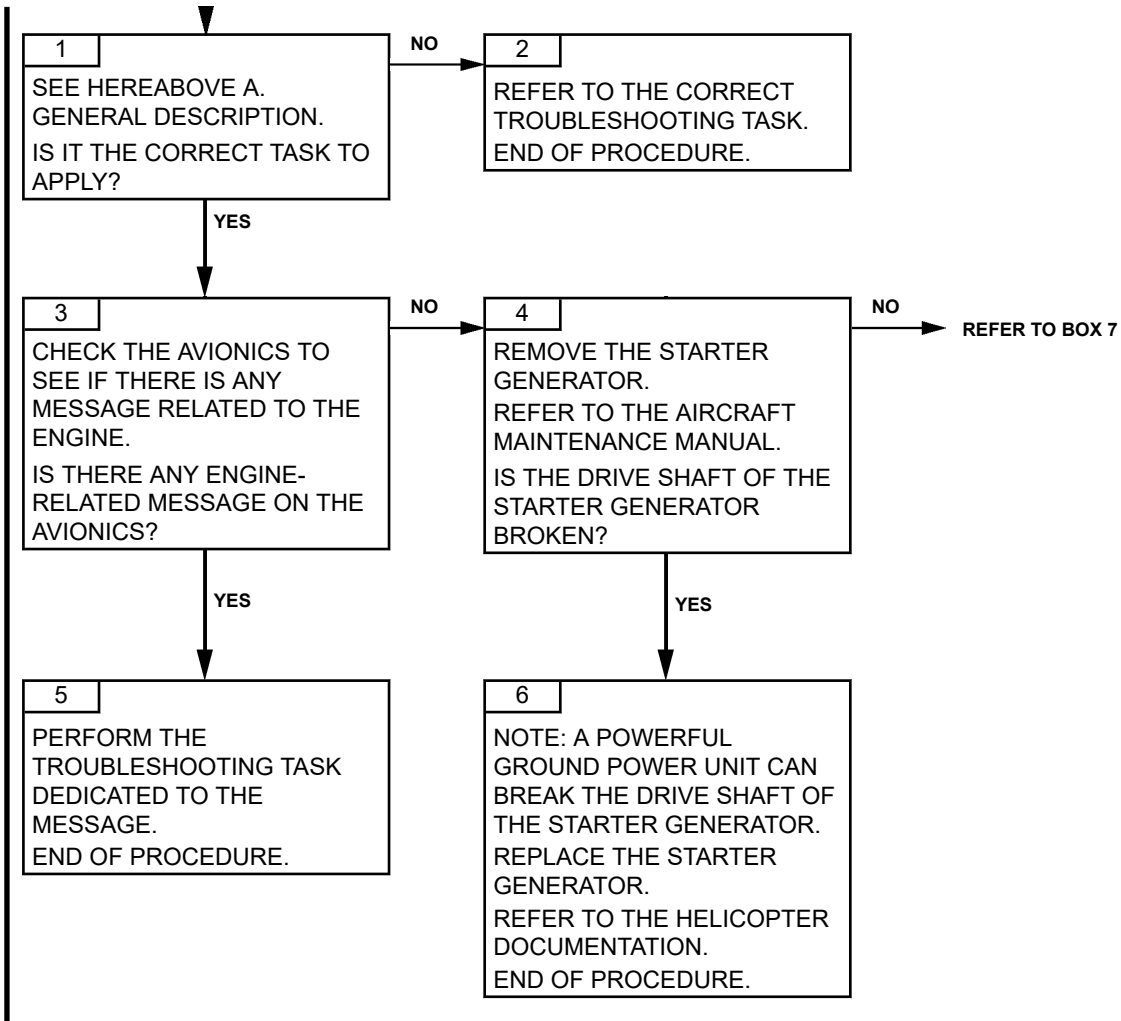

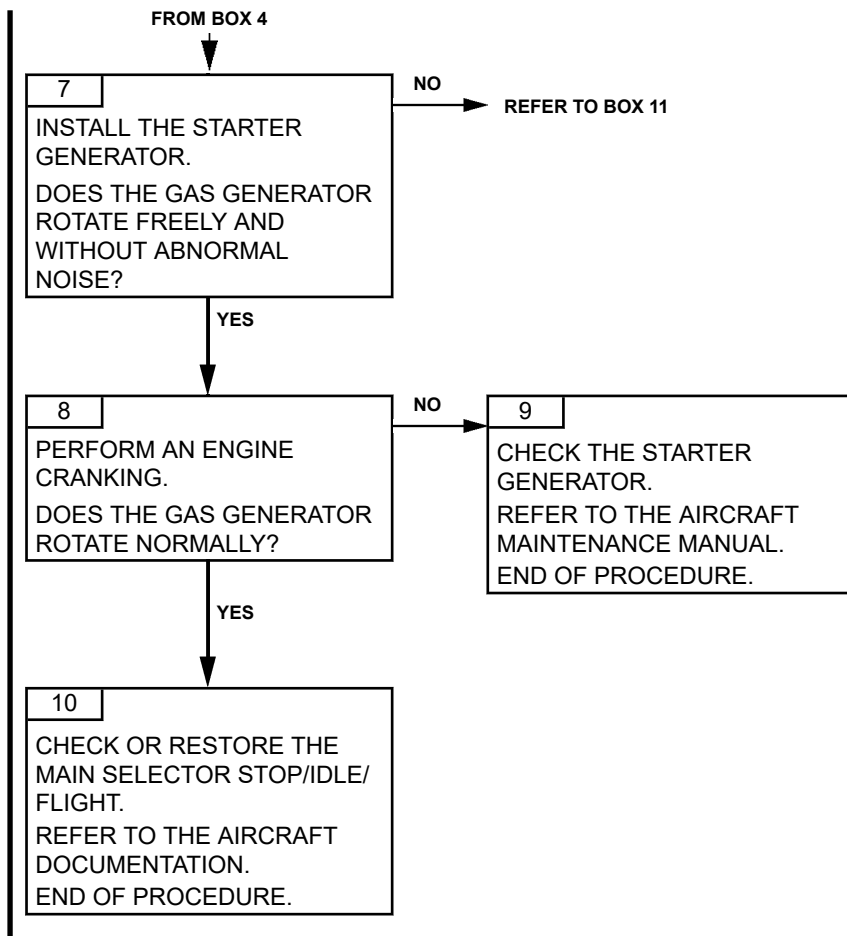

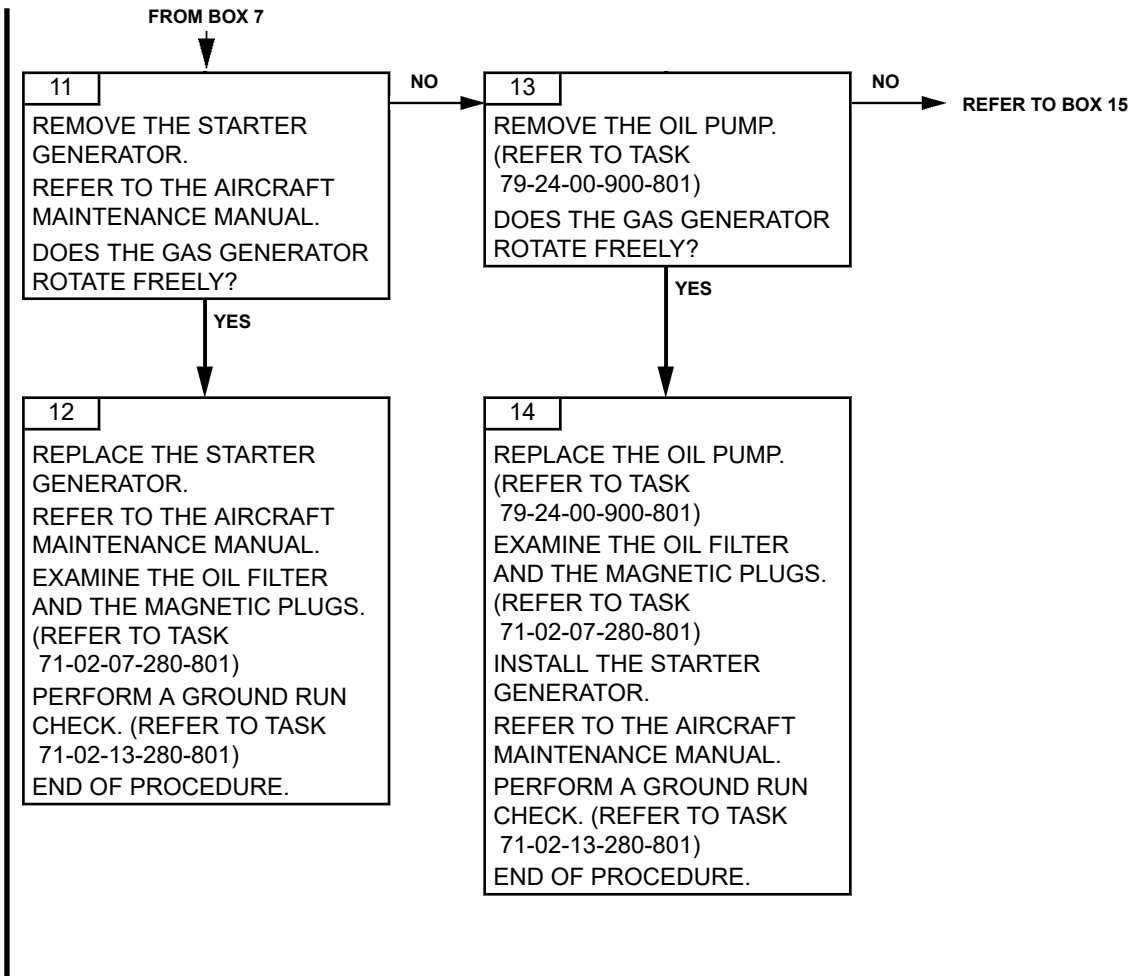

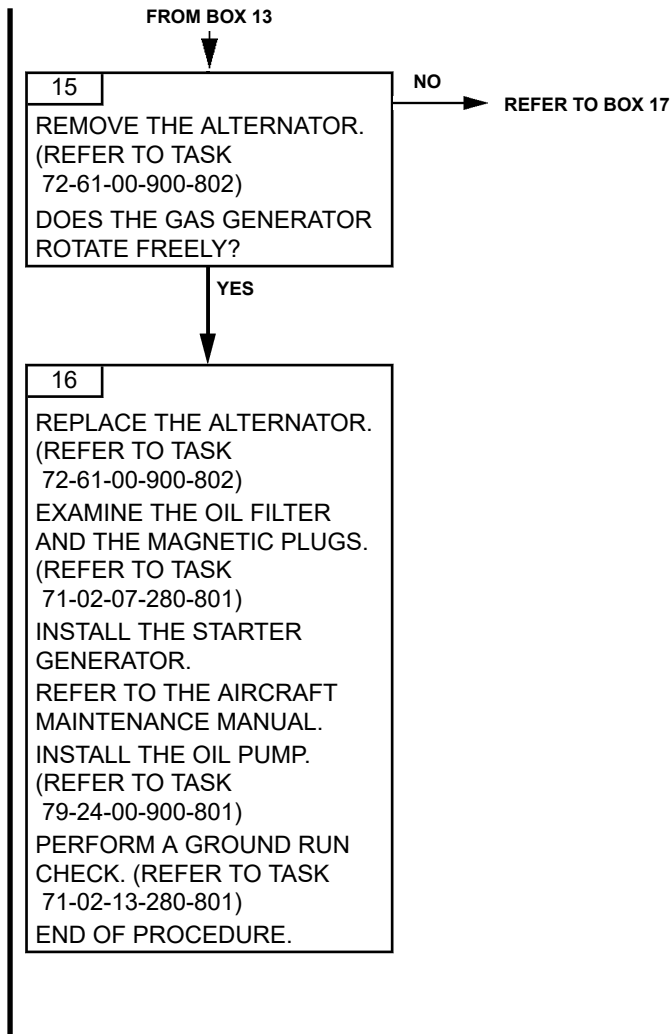

FROM BOX 15

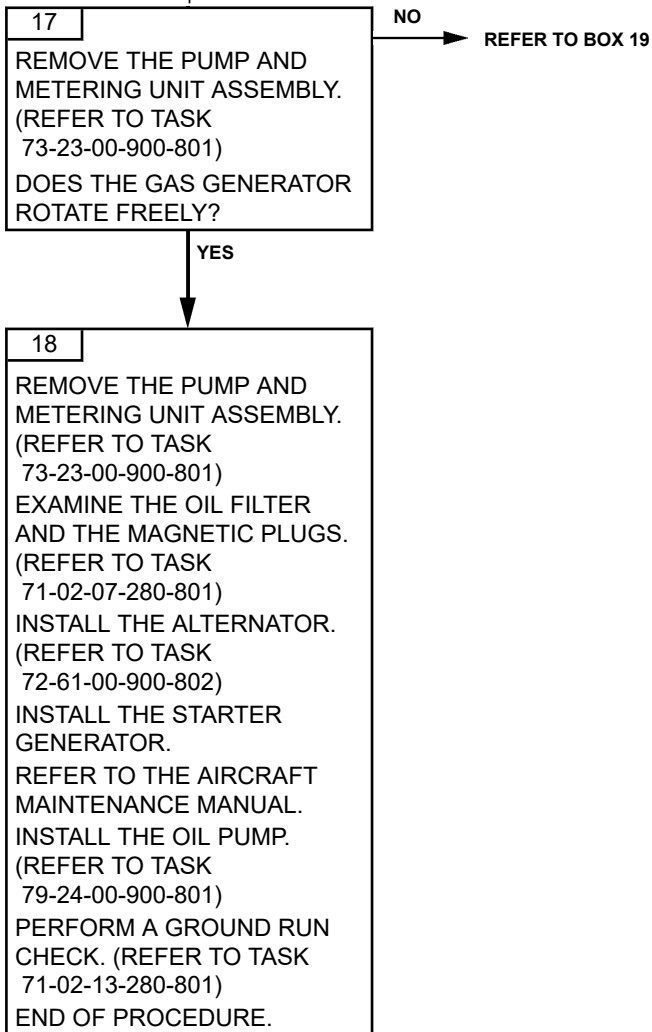

ARRIEL 2 C1

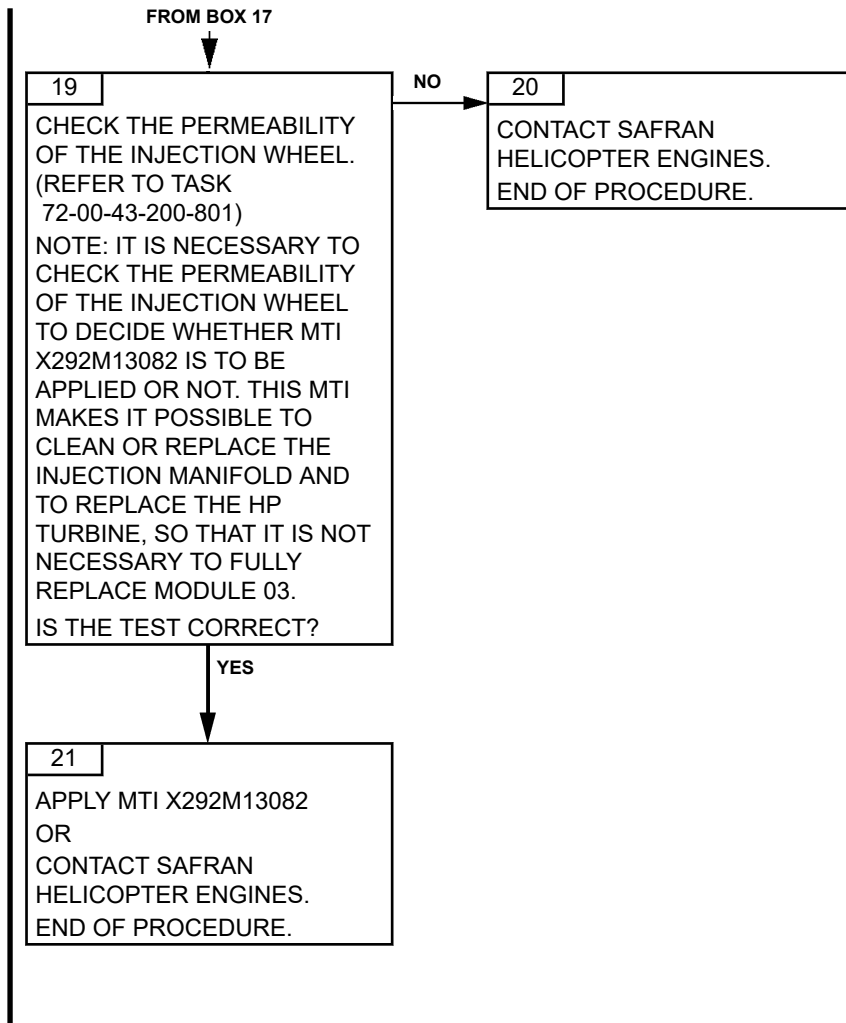

PAGE LEFT BLANK INTENTIONALLY

TASK 71-00-06-812-806-A01

ENG P ON - NO EXTINGUISHING OF THE LOW OIL PRESSURE SIGNAL TROUBLESHOOTING

1. GENERAL

A. PHASE AND FAILURE DETECTION

<i>Phase</i>	<i>Indication</i>	
	<i>Alarms VEMD</i>	<i>Warning indicator lights</i>
AT STARTING		Red ENG 1 or ENG 2 on

B. REMINDER OF THE NORMAL OPERATING CONDITION

The oil pressure indication is normal and the ENG1 or ENG2 lights are off at ground idle.

C. POSSIBLE CAUSES

- Low-oil pressure switch
- Control and monitoring harness
- Aircraft

2. PROCEDURE

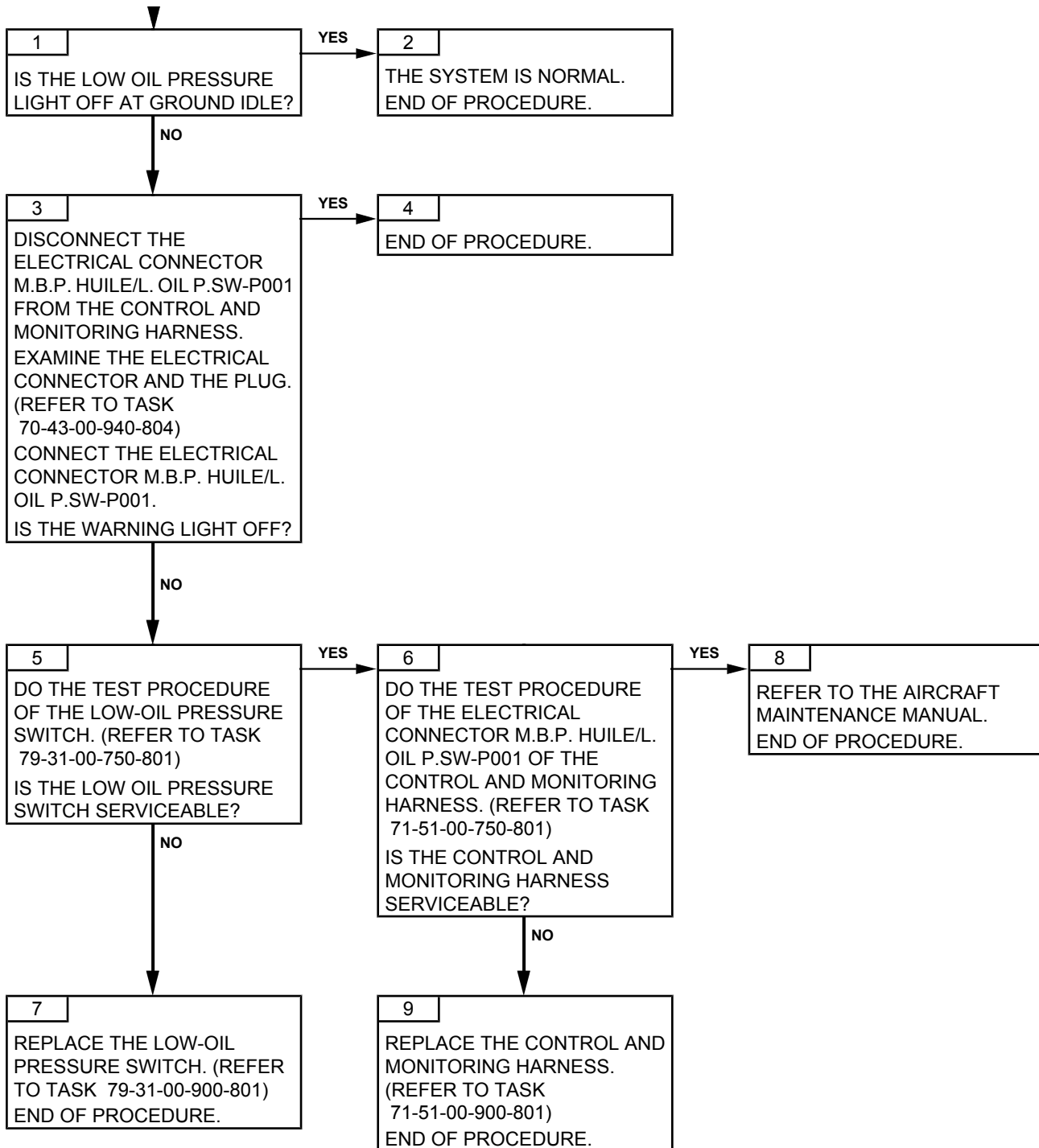

TASK 71-00-06-812-807-A01

**ABORTED START - NO IGNITION
TROUBLESHOOTING****1. GENERAL****A. GENERAL DESCRIPTION**

In the troubleshooting book, there are different troubleshooting tasks concerning aborted start. Titles are:

- **“Aborted start: gas generator not driven”**: Do this troubleshooting task if the gas generator is not driven at all (N1 = 0 %) at the engine start selection or during cranking.
- **“Aborted start: no ignition”**: When the pilot turns the main selector STOP/IDLE/FLIGHT to IDLE or FLIGHT, the EECU launches the starting sequence. At starting, the gas generator is driven but no ignition of the combustion chamber (T4 does not increase).
- **“Aborted start: first start aborted”**: Do this **preventive task** when there are starting difficulties only at the first start of the day, or after the aircraft has been sitting for several hours, i.e. the engine is at ambient temperature.
- **“Aborted start: slow start or stagnation”**: Do this troubleshooting task when the ignition in the combustion chamber is observed, but the N1 speed increases more slowly than usual, or the N1 speed stops increasing during start (and the pilot has to abort manually the starting sequence).
- **“Aborted start: flames at the exhaust pipe”**: Do this troubleshooting task when the starting sequence generates abnormal flames at the exhaust pipe.
- **“Aborted start: flame out”**: Do this troubleshooting task when ignition is observed, the N1 speed increases but the combustion chamber flames out without any action by the pilot.
- **“T4.5 limitations exceeded”**: Do this troubleshooting task when a T4.5 overtemperature is observed during engine running or during starting sequence.

B. POSSIBLE CAUSES

- Igniters plugs
- Ignition unit
- Ignition cable
- Fuel valve assembly
- Start injectors
- Control and monitoring harness
- Pump and metering unit assembly
- Start air purge valve
- EECU
- Aircraft.

2. PROCEDURE

NOTE: *1. In case of a recent maintenance operation performed on this engine or on the aircraft starting system (starter, battery, fuse, selector, harness...), check first the sub-assembly concerned by this maintenance operation, in particular the plug and connectors.*

NOTE: *2. It is possible to interchange an equipment item with another engine.*

Effectivity: C1

Failures observed during engine operation

- *If the engine starts normally, both equipment items should be reinstalled in their original location in order to confirm the anomaly. If the anomaly is confirmed, then the unserviceable equipment item has to be replaced.*
- *If the engine does not start normally, both the equipment items should be reinstalled in their original location and you should perform the next step of the troubleshooting tree.*

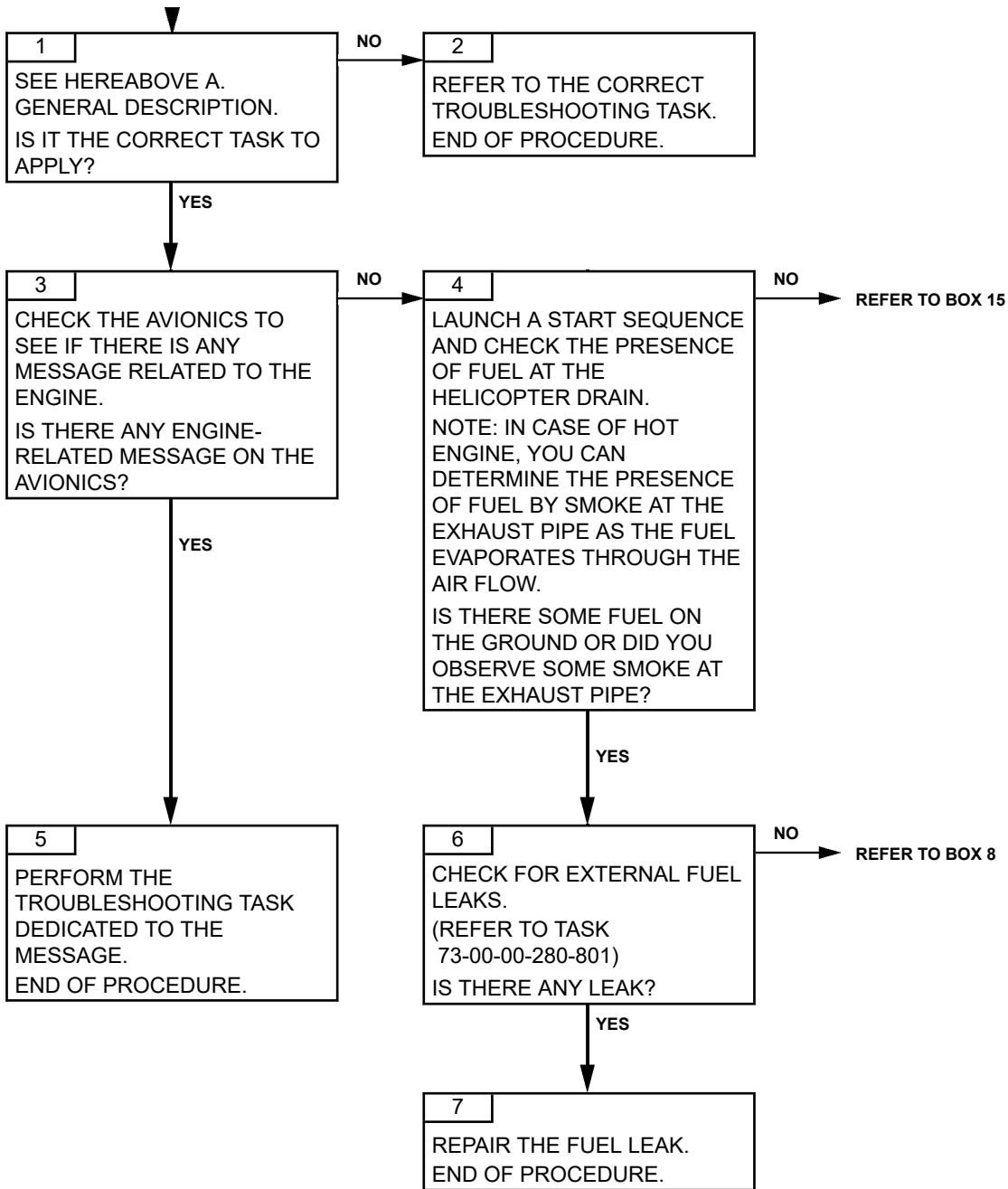

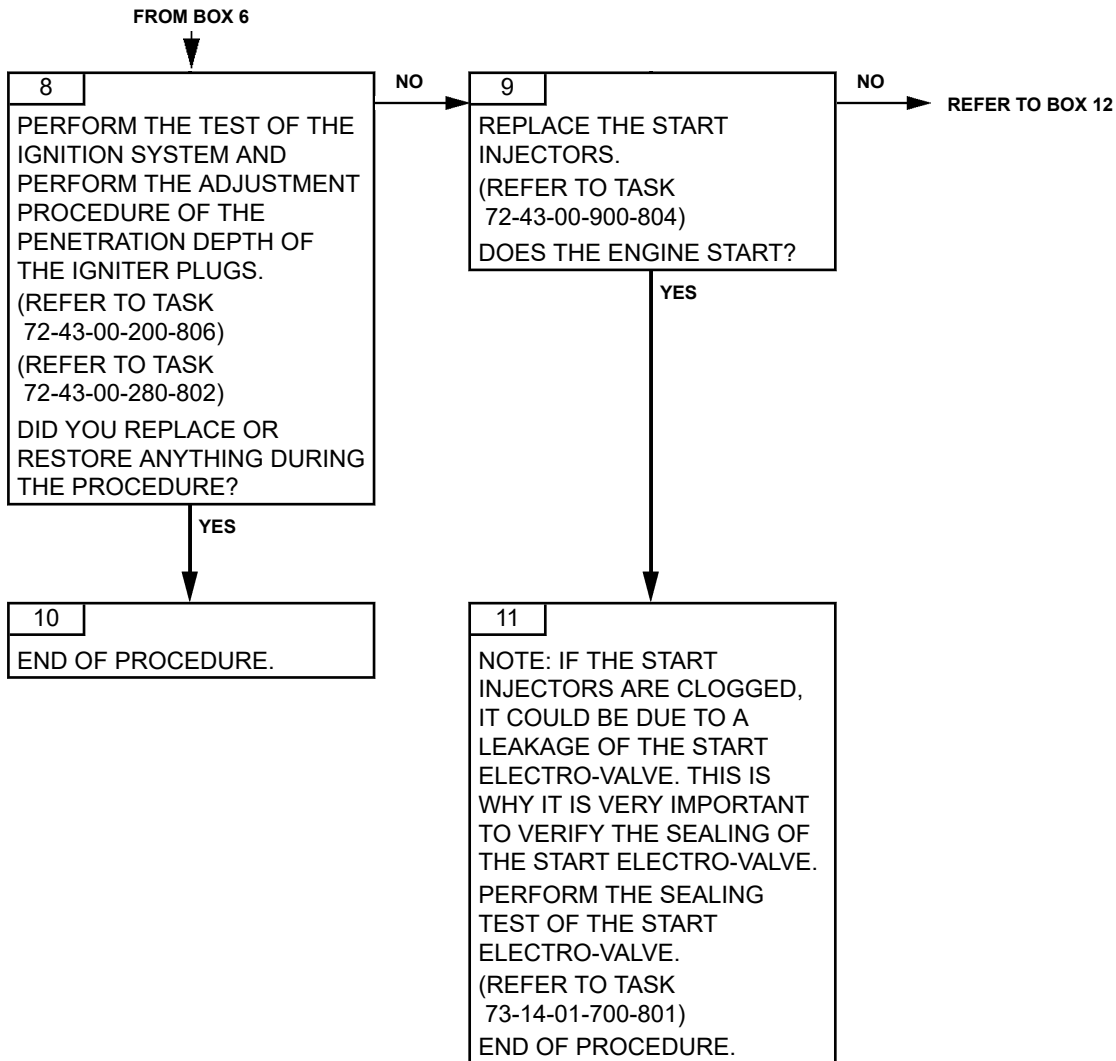

ARRIEL 2 C1

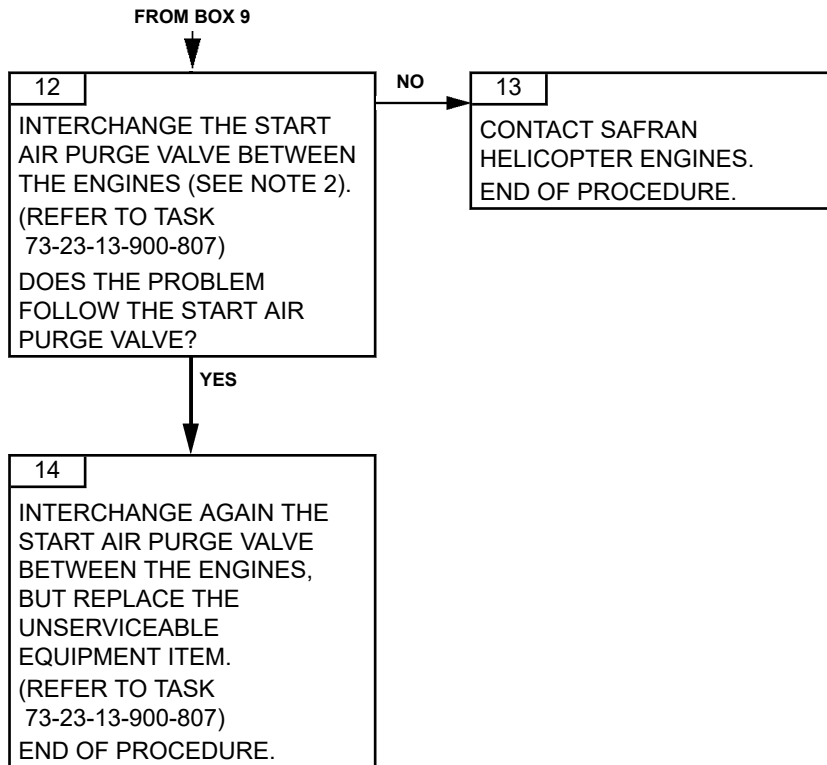

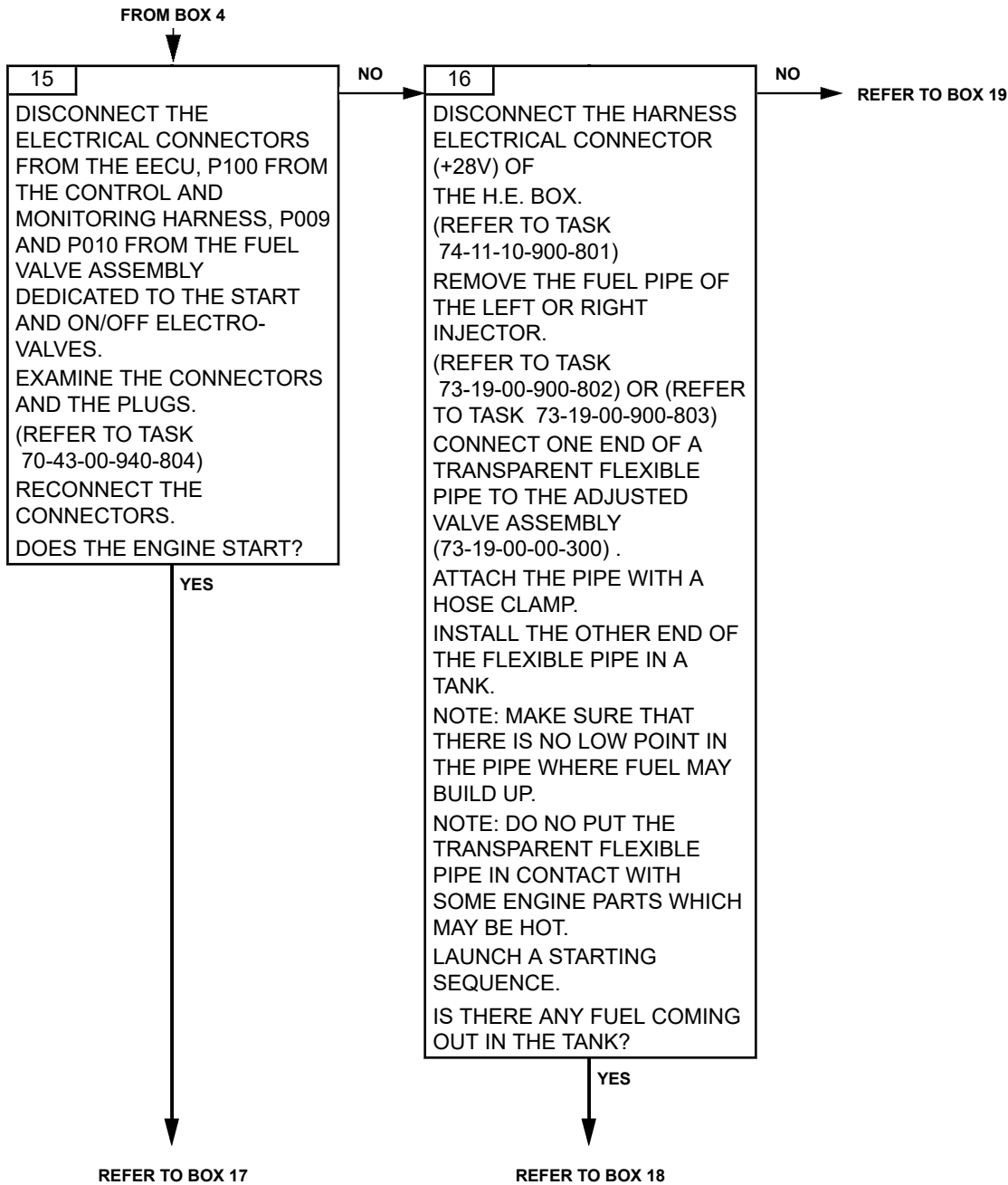

FROM BOX 15



17
END OF PROCEDURE.

FROM BOX 16



18
REPLACE THE START INJECTORS.
(REFER TO TASK 72-43-00-900-804)
NOTE: IF THE START INJECTORS ARE CLOGGED, IT COULD BE DUE TO A LEAKAGE OF THE START ELECTRO-VALVE. THIS IS WHY IT IS VERY IMPORTANT TO VERIFY THE SEALING OF THE START ELECTRO-VALVE. PERFORM THE SEALING TEST OF THE START ELECTRO-VALVE.
(REFER TO TASK 73-14-01-700-801)
END OF PROCEDURE.

FROM BOX 16

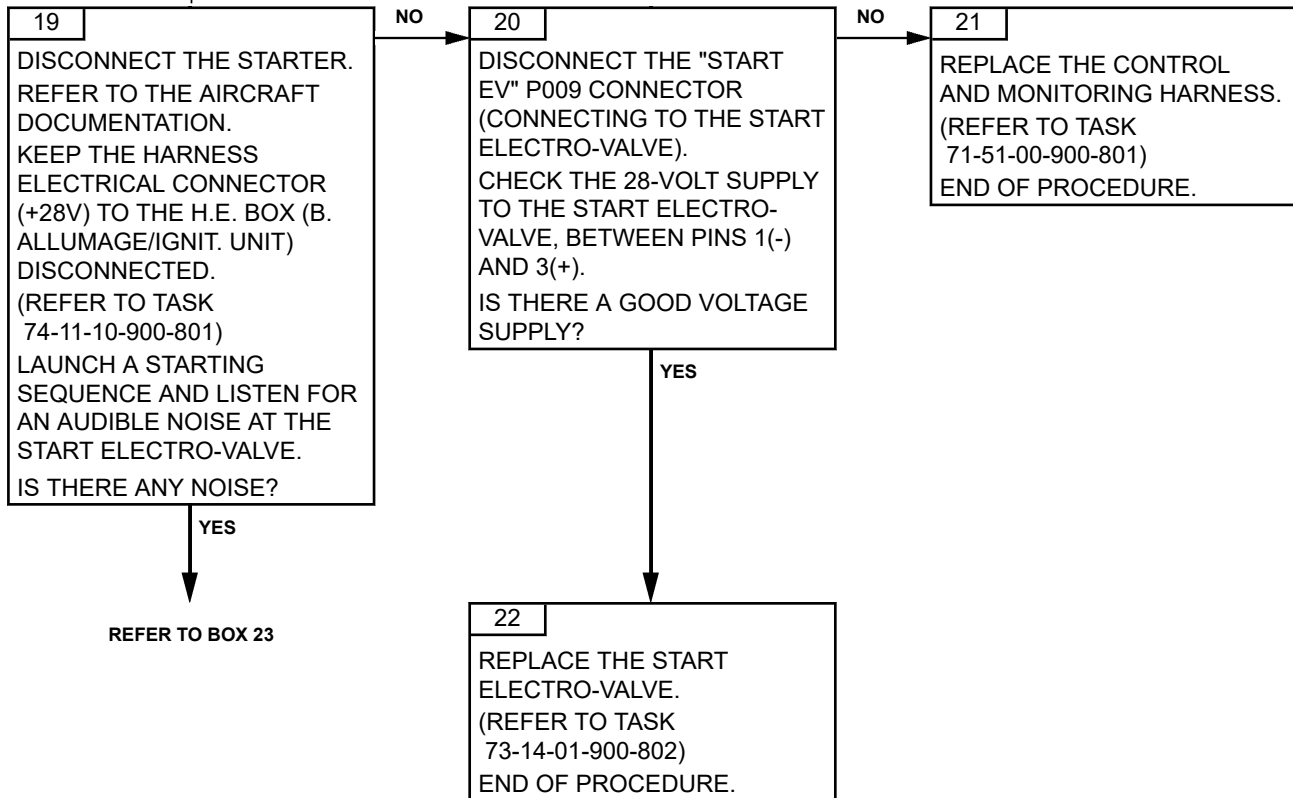

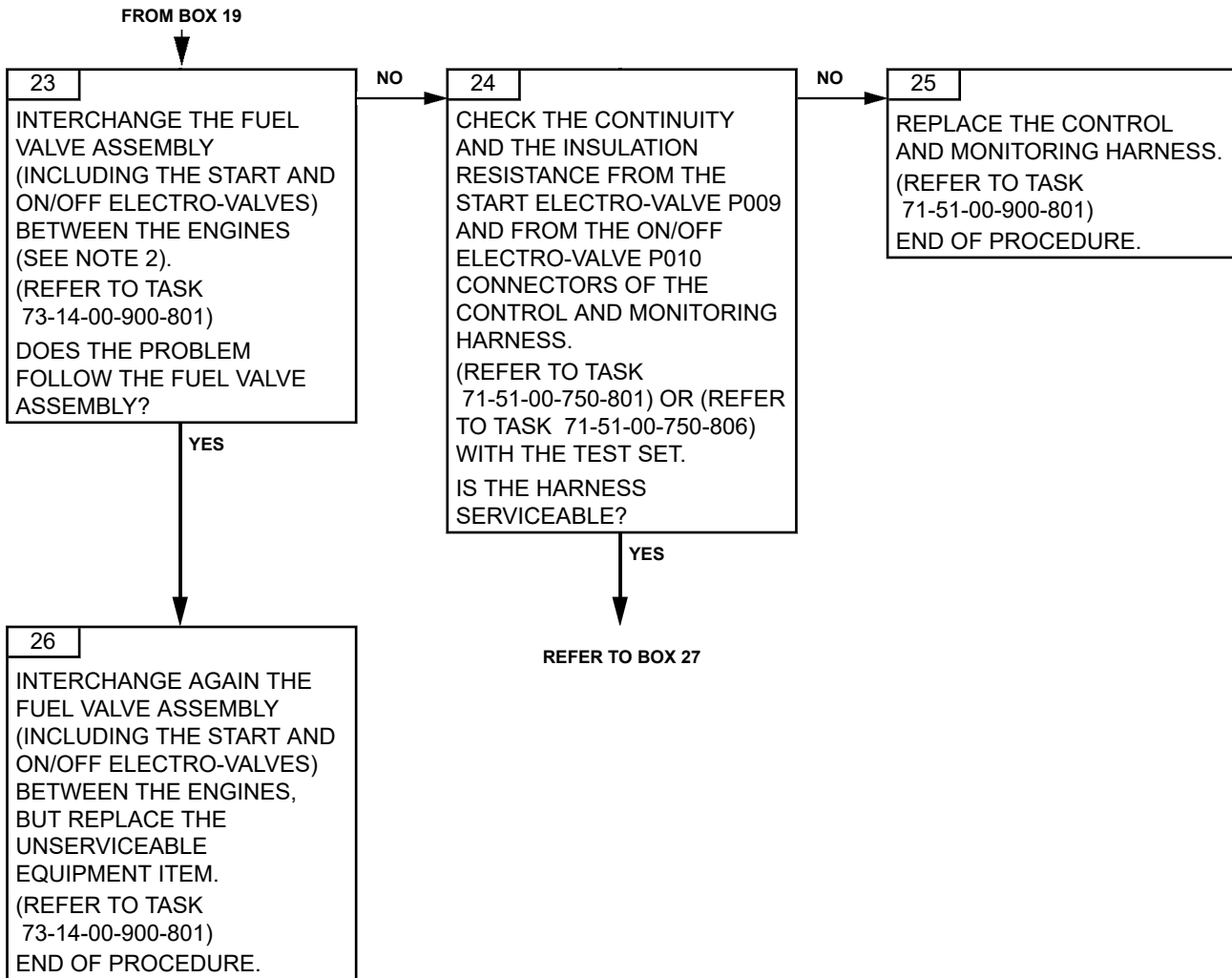

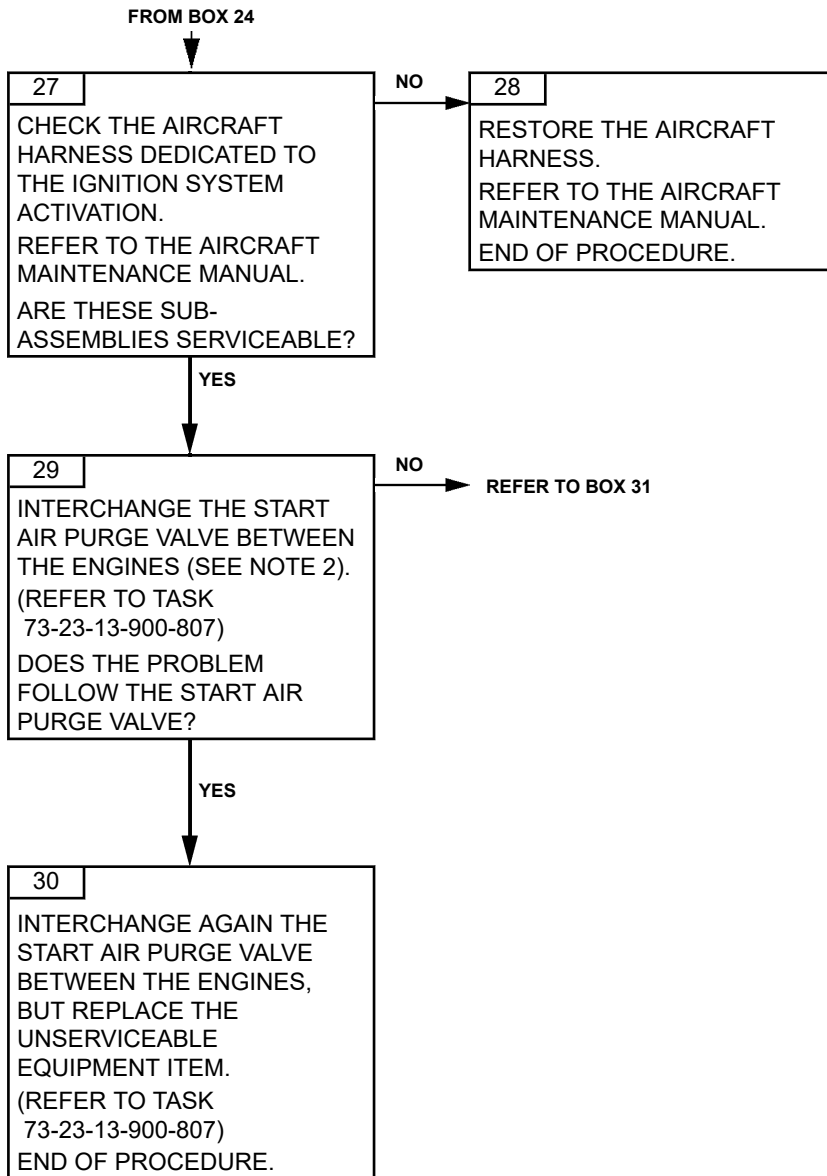

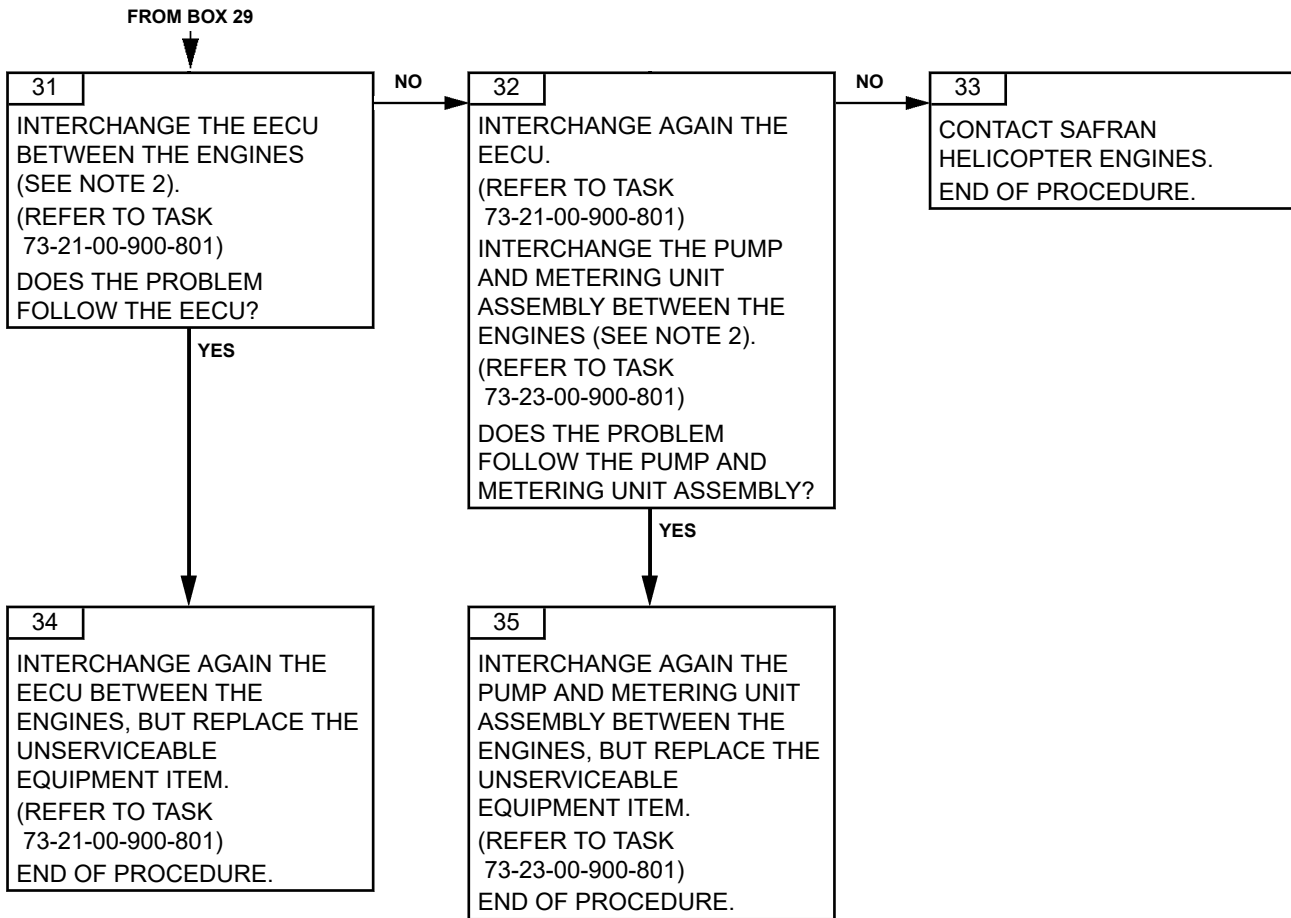

PAGE LEFT BLANK INTENTIONALLY

TASK 71-00-06-812-808-A01

**ABORTED START - SLOW START OR STAGNATION
TROUBLESHOOTING****1. GENERAL****A. GENERAL DESCRIPTION**

In the troubleshooting book, there are different troubleshooting tasks concerning aborted start. Titles are:

- **“Aborted start: gas generator not driven”**: Do this troubleshooting task if the gas generator is not driven at all (N1 = 0 %) at the engine start selection or during cranking.
- **“Aborted start: no ignition”**: When the pilot turns the main selector STOP/IDLE/FLIGHT to IDLE or FLIGHT, the EECU launches the starting sequence. At starting, the gas generator is driven but no ignition of the combustion chamber (T4 does not increase).
- **“Aborted start: first start aborted”**: Do this **preventive task** when there are starting difficulties only at the first start of the day, or after the aircraft has been sitting for several hours, i.e. the engine is at ambient temperature.
- **“Aborted start: slow start or stagnation”**: Do this troubleshooting task when the ignition in the combustion chamber is observed, but the N1 speed increases more slowly than usual, or the N1 speed stops increasing during start (and the pilot has to abort manually the starting sequence).
- **“Aborted start: flames at the exhaust pipe”**: Do this troubleshooting task when the starting sequence generates abnormal flames at the exhaust pipe.
- **“Aborted start: flame out”**: Do this troubleshooting task when ignition is observed, the N1 speed increases but the combustion chamber flames out without any action by the pilot.
- **“T4.5 limitations exceeded”**: Do this troubleshooting task when a T4.5 overtemperature is observed during engine running or during starting sequence.

B. POSSIBLE CAUSES

- Pyrometric harness
- Fuel valve assembly (Pressurizing valve not LRU)
- Start electro-valve
- Start air purge valve
- Junction and T4.5 conformation box

2. PROCEDURE

NOTE: *1. In case of a recent maintenance operation performed on this engine or on the aircraft starting system (starter, battery, fuse, selector, harness...), check first the sub-assembly concerned by this maintenance operation, in particular the plug and connectors.*

NOTE: *2. It is possible to interchange an equipment item with another engine.*

- *If the engine starts normally, both equipment items should be reinstalled in their original location in order to confirm the anomaly. If the anomaly is confirmed, then the unserviceable equipment item has to be replaced.*

Effectivity: C1

Failures observed during engine operation

- *If the engine does not start normally, both the equipment items should be reinstalled in their original location and you should perform the next step of the troubleshooting tree.*

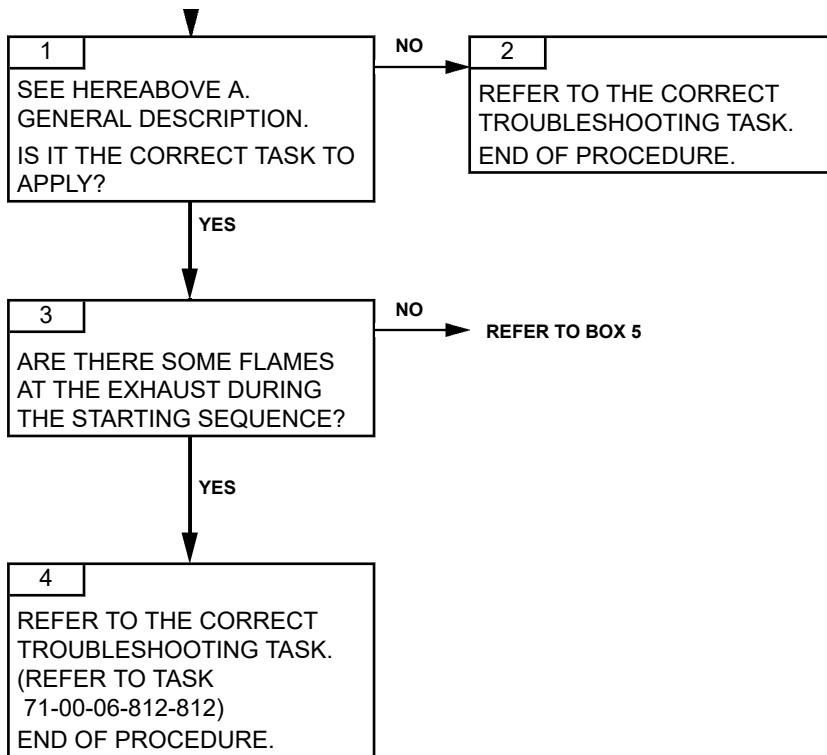

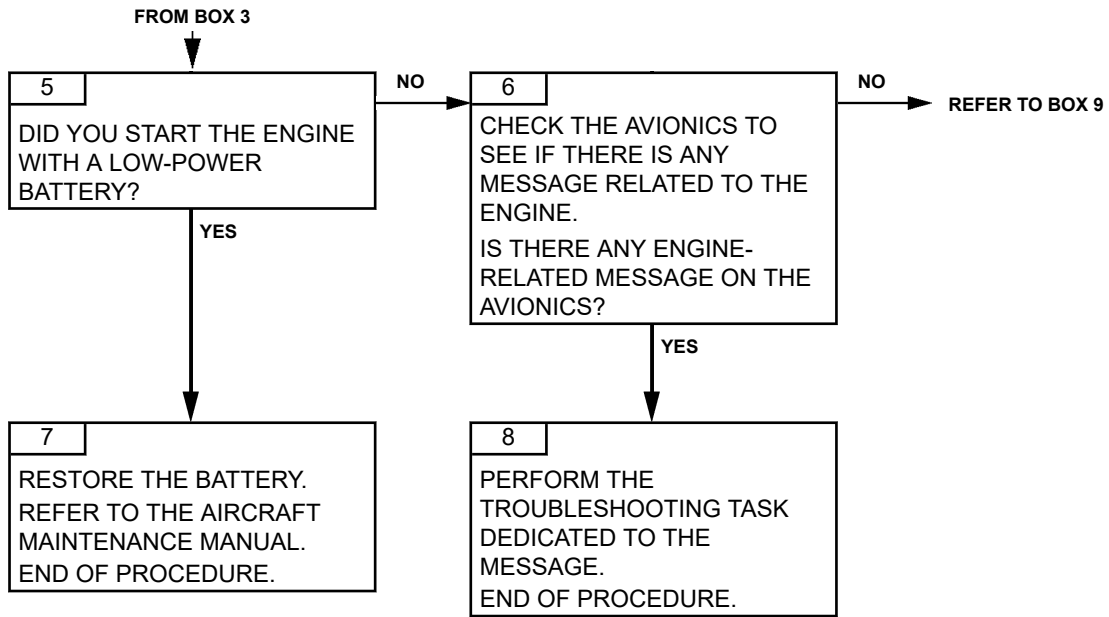

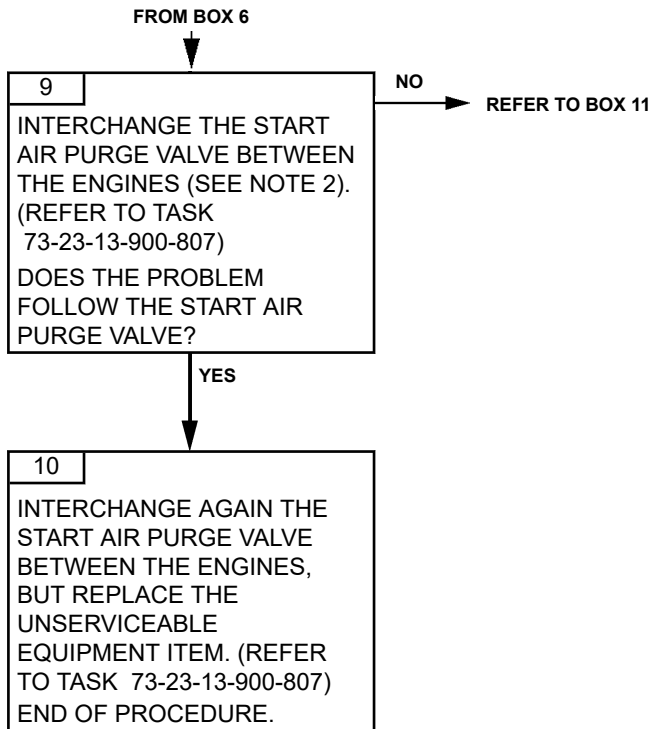

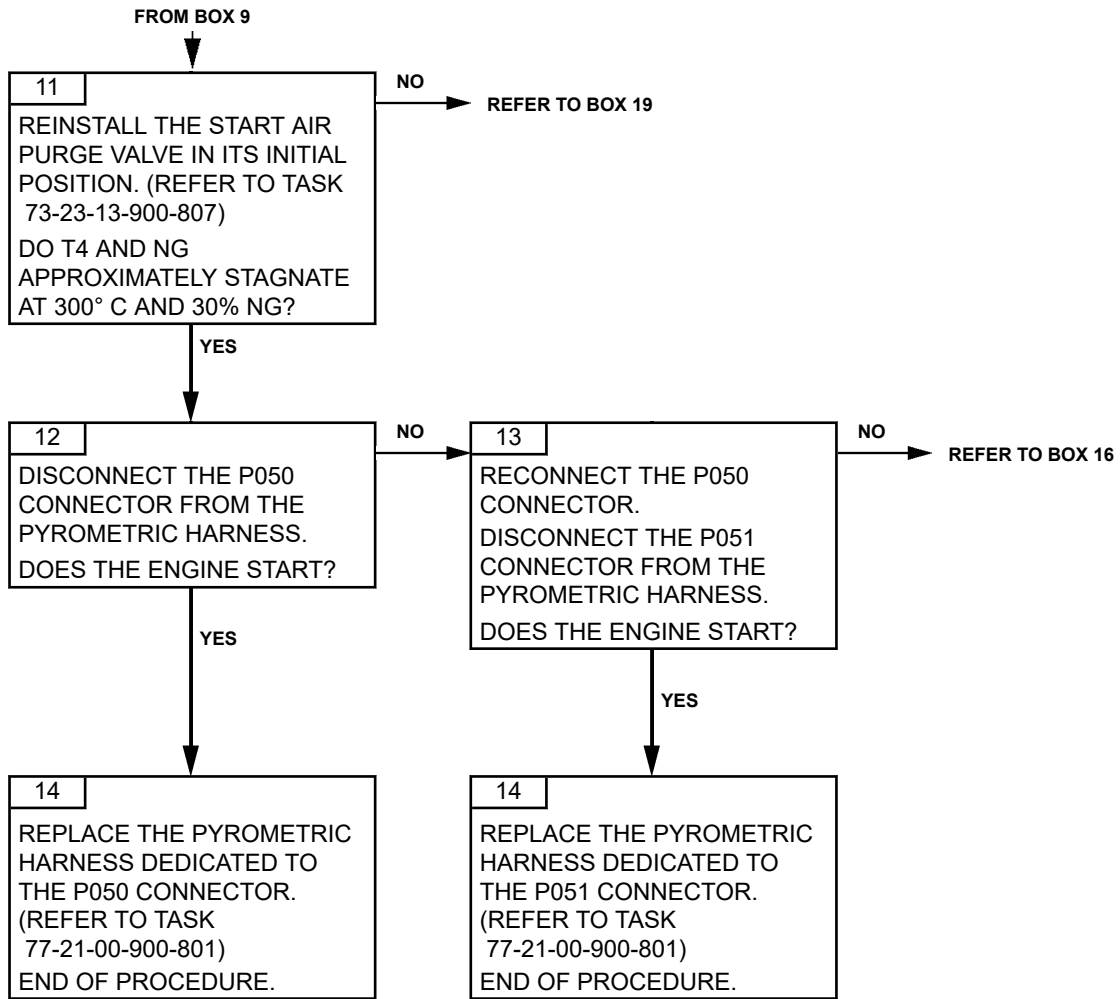

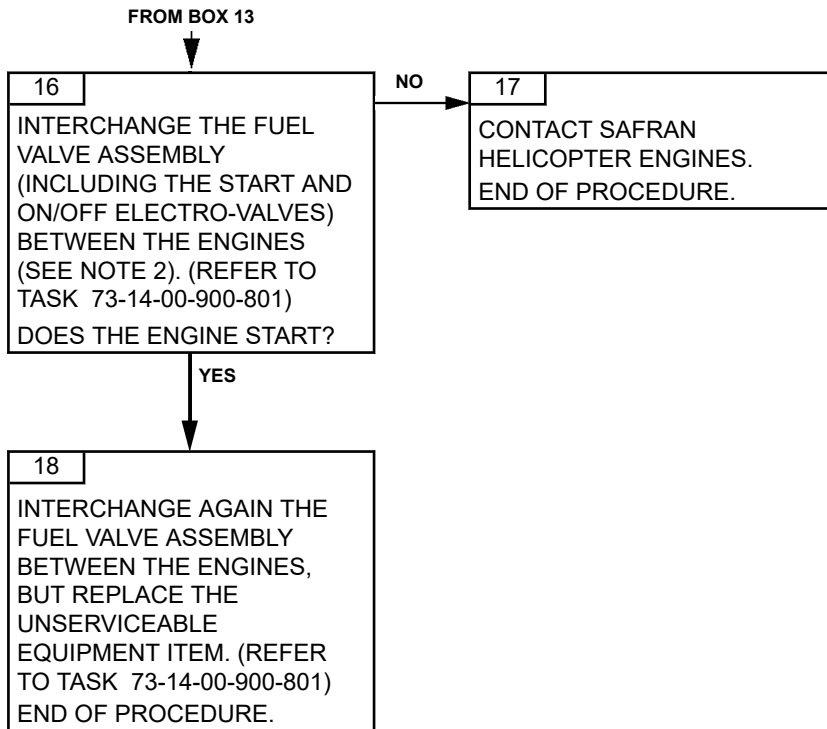

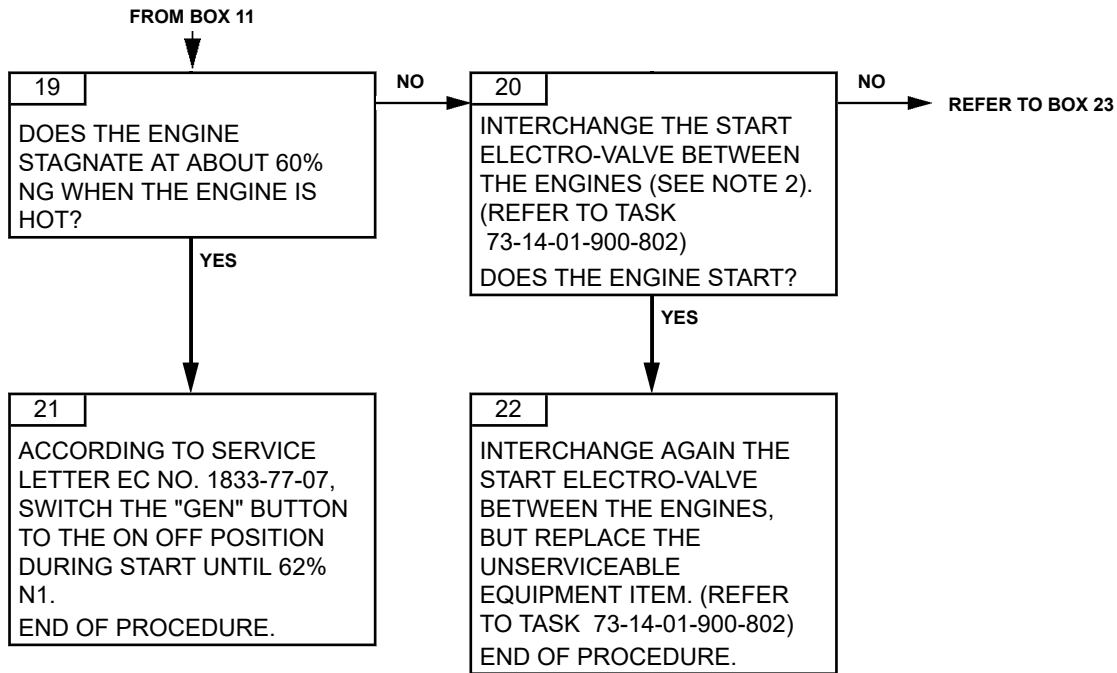

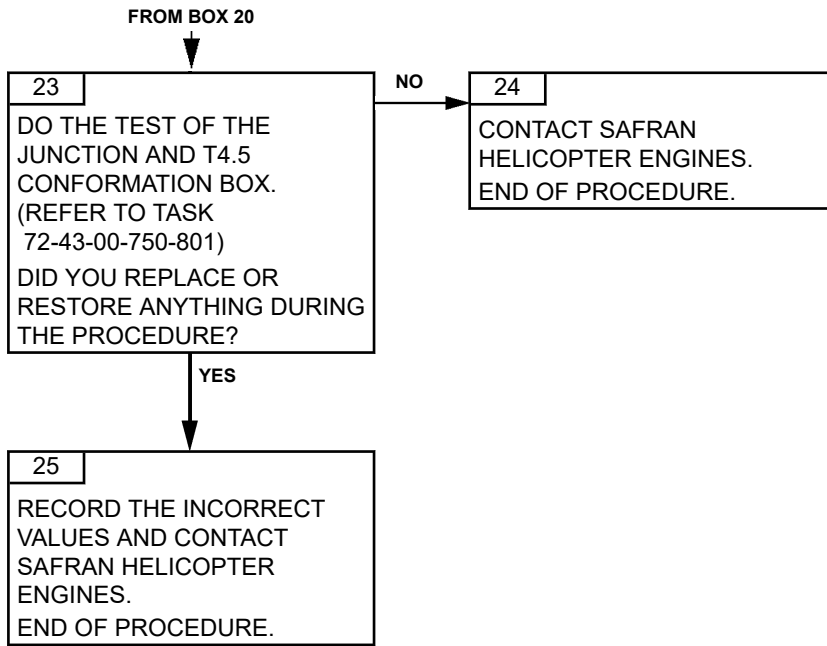

TASK 71-00-06-812-810-A01

**ABORTED START - FLAME OUT
TROUBLESHOOTING****1. GENERAL****A. GENERAL DESCRIPTION**

In the troubleshooting book, there are different troubleshooting tasks concerning aborted start. Titles are:

- **“Aborted start: gas generator not driven”**: Do this troubleshooting task if the gas generator is not driven at all (N1 = 0 %) at the engine start selection or during cranking.
- **“Aborted start: no ignition”**: When the pilot turns the main selector STOP/IDLE/FLIGHT to IDLE or FLIGHT, the EECU launches the starting sequence. At starting, the gas generator is driven but no ignition of the combustion chamber (T4 does not increase).
- **“Aborted start: first start aborted”**: Do this **preventive task** when there are starting difficulties only at the first start of the day, or after the aircraft has been sitting for several hours, i.e. the engine is at ambient temperature.
- **“Aborted start: slow start or stagnation”**: Do this troubleshooting task when the ignition in the combustion chamber is observed, but the N1 speed increases more slowly than usual, or the N1 speed stops increasing during start (and the pilot has to abort manually the starting sequence).
- **“Aborted start: flames at the exhaust pipe”**: Do this troubleshooting task when the starting sequence generates abnormal flames at the exhaust pipe.
- **“Aborted start: flame out”**: Do this troubleshooting task when ignition is observed, the N1 speed increases but the combustion chamber flames out without any action by the pilot.
- **“T4.5 limitations exceeded”**: Do this troubleshooting task when a T4.5 overtemperature is observed during engine running or during starting sequence.

B. POSSIBLE CAUSES

- Fuel valve assembly

2. PROCEDURE

NOTE: 1. *In case of a recent maintenance operation performed on this engine or on the aircraft starting system (starter, battery, fuse, selector, harness...), check first the sub-assembly concerned by this maintenance operation, in particular the plug and connectors.*

NOTE: 2. *It is possible to interchange an equipment item with another engine.*

- *If the engine starts normally, both equipment items should be reinstalled in their original location in order to confirm the anomaly. If the anomaly is confirmed, then the unserviceable equipment item has to be replaced.*
- *If the engine does not start normally, both the equipment items should be reinstalled in their original location and you should perform the next step of the troubleshooting tree.*

Effectivity: C1

Failures observed during engine operation

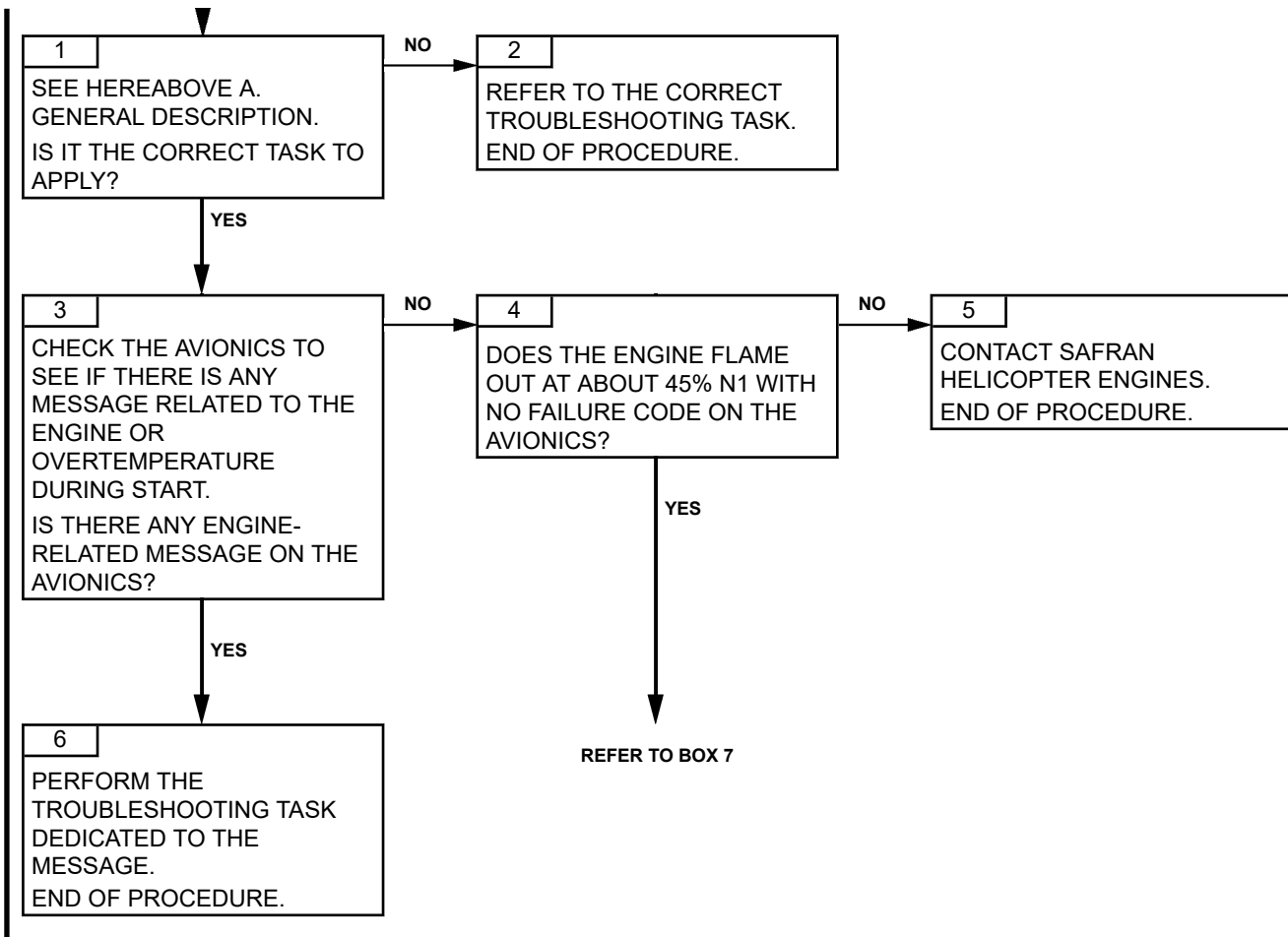

ARRIEL 2 C1

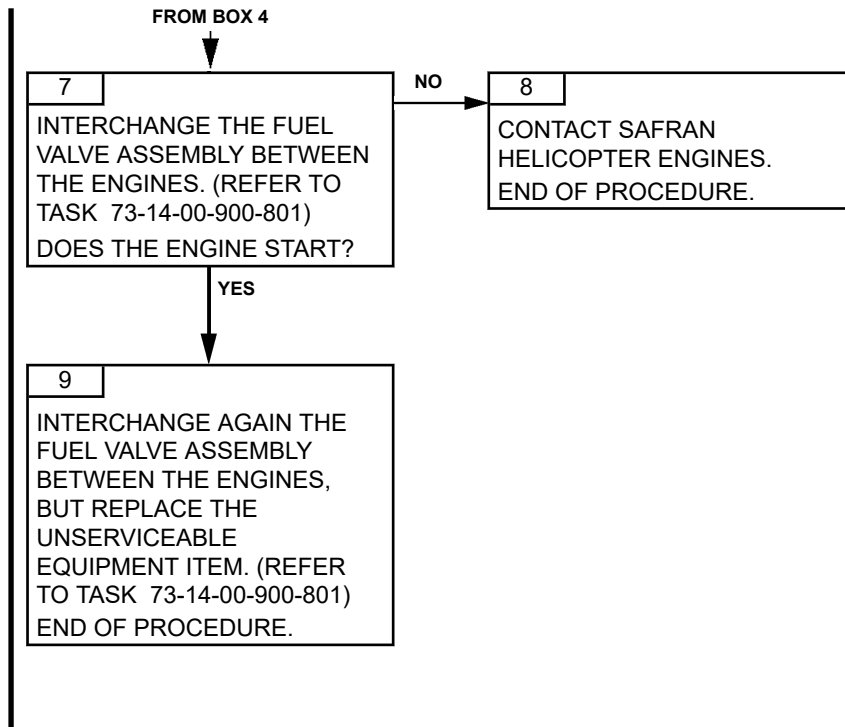

PAGE LEFT BLANK INTENTIONALLY

TASK 71-00-06-812-811-A01

**ABORTED START - FIRST START ABORTED
TROUBLESHOOTING****1. GENERAL****A. GENERAL DESCRIPTION**

In the troubleshooting book, there are different troubleshooting tasks concerning aborted start. Titles are:

- **“Aborted start: gas generator not driven”**: Do this troubleshooting task if the gas generator is not driven at all (N1 = 0%) at the engine start selection or during cranking.
- **“Aborted start: no ignition”**: When the pilot turns the main selector STOP/IDLE/FLIGHT to IDLE or FLIGHT, the EECU launches the starting sequence. At starting, the gas generator is driven but no ignition of the combustion chamber (T4 does not increase).
- **“Aborted start: first start aborted”**: Do this preventive task when there are starting difficulties only at the first start of the day, or after the aircraft has been sitting for several hours, i.e. the engine is at ambient temperature.
- **“Aborted start: slow start or stagnation”**: Do this troubleshooting task when ignition in the combustion chamber is observed, but the N1 speed increases more slowly than usual, or the N1 speed stops increasing during start (and the pilot has to abort manually the starting sequence).
- **“Aborted start: flames at the exhaust pipe”**: Do this troubleshooting task when the starting sequence generates abnormal flames at the exhaust pipe.
- **“Aborted start: flame out”**: Do this troubleshooting task when ignition is observed, the N1 speed increases but the combustion chamber flames go out without any action by the pilot.
- **“T4.5 limitations exceeded”**: Do this troubleshooting task when a T4.5 overtemperature is observed during engine running or during starting sequence.

B. POSSIBLE CAUSES

- Start air purge valve
- VARILIP seal from the pump and metering unit
- Aircraft (boost pump)

2. PROCEDURE

NOTE: *1. In case of a recent maintenance operation performed on this engine or on the aircraft starting system (starter, battery, fuse, selector, harness...), check first the sub-assembly concerned by this maintenance operation, in particular the plug and connectors.*

NOTE: *It is possible to interchange an equipment item with another engine.*

- *If the engine starts normally, both equipment items should be reinstalled in their original location in order to confirm the anomaly. If the anomaly is confirmed, then the unserviceable equipment has to be replaced.*
- *- If the engine does not start normally, both the equipment items should be reinstalled in their original location and you should perform the next step of the troubleshooting tree.*

Effectivity: C1

Failures observed during engine operation

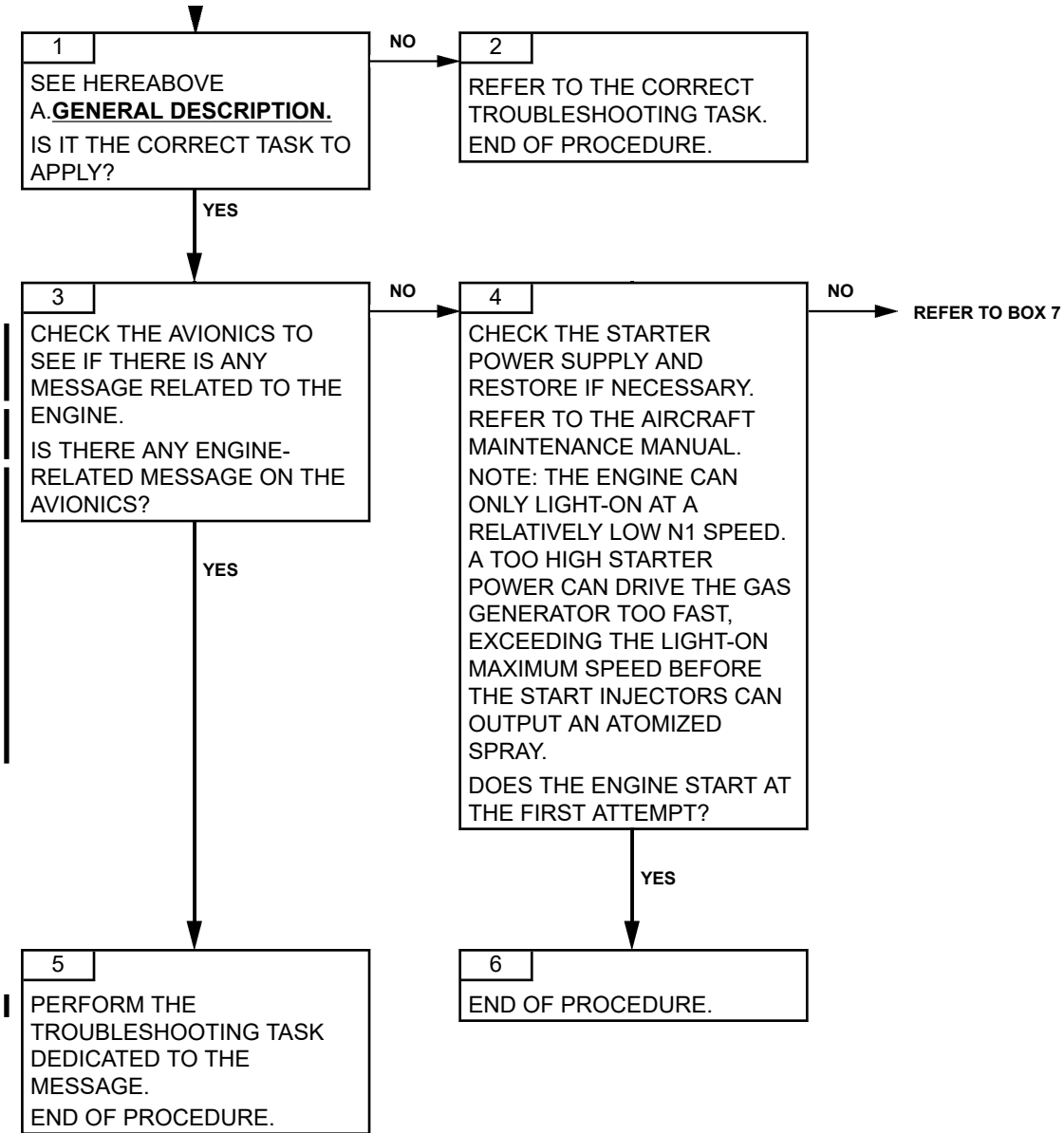

ARRIEL 2 C1

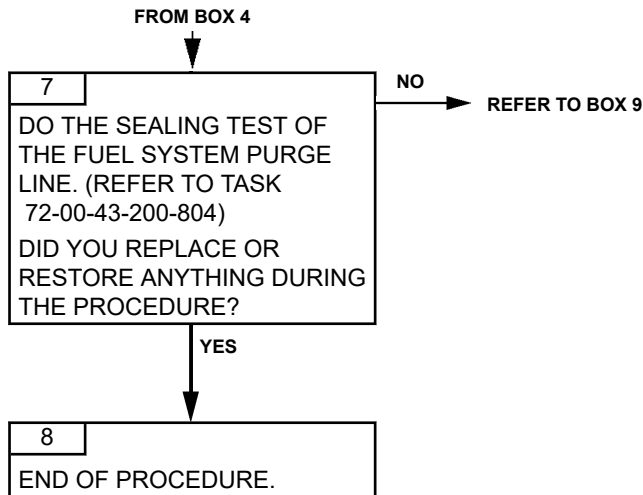

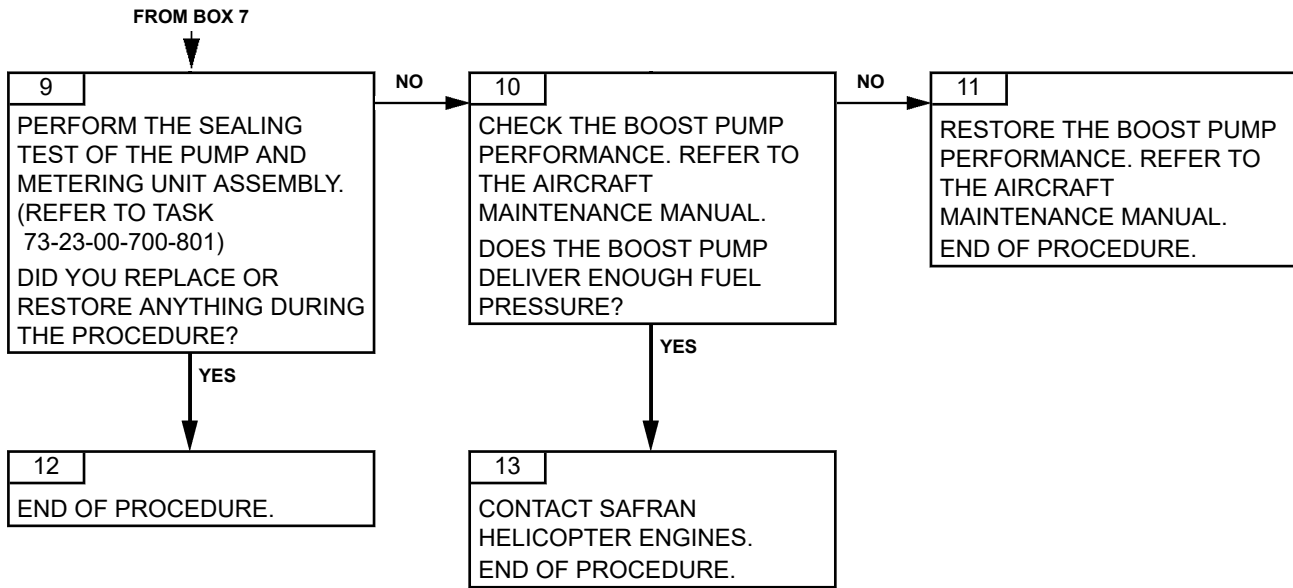

TASK 71-00-06-812-812-A01

**ABORTED START - FLAMES AT THE EXHAUST PIPE
TROUBLESHOOTING****1. GENERAL****A. GENERAL DESCRIPTION**

In the troubleshooting book, there are different troubleshooting tasks concerning aborted start. Titles are:

- **“Aborted start: gas generator not driven”**: Do this troubleshooting task if the gas generator is not driven at all (N1 = 0%) at the engine start selection or during cranking.
- **“Aborted start: no ignition”**: When the pilot turns the main selector STOP/IDLE/FLIGHT to IDLE or FLIGHT, the EECU launches the starting sequence. At starting, the gas generator is driven but no ignition of the combustion chamber (T4 does not increase).
- **“Aborted start: first start aborted”**: Do this preventive task when there are starting difficulties only at the first start of the day, or after the aircraft has been sitting for several hours, i.e. the engine is at ambient temperature.
- **“Aborted start: slow start or stagnation”**: Do this troubleshooting task when ignition in the combustion chamber is observed, but the N1 speed increases more slowly than usual, or the N1 speed stops increasing during start (and the pilot has to abort manually the starting sequence).
- **“Aborted start: flames at the exhaust pipe”**: Do this troubleshooting task when the starting sequence generates abnormal flames at the exhaust pipe.
- **“Aborted start: flame out”**: Do this troubleshooting task when ignition is observed, the N1 speed increases but the combustion chamber flames out without any action by the pilot.
- **“T4.5 limitations exceeded”**: Do this troubleshooting task when a T4.5 overtemperature is observed during engine running or during starting sequence.

B. POSSIBLE CAUSES

- Start injectors
- Combustion chamber drain valve

2. PROCEDURE

NOTE: *1. In case of a recent maintenance operation performed on this engine or on the aircraft starting system (starter, battery, fuse, selector, harness...), check first the sub-assembly concerned by this maintenance operation, in particular the plug and connectors.*

NOTE: *It is possible to interchange an equipment item with another engine.*

- *If the engine starts normally, both equipment items should be reinstalled in their original location in order to confirm the anomaly. If the anomaly is confirmed, then the unserviceable equipment has to be replaced.*
- *- If the engine does not start normally, both the equipment items should be reinstalled in their original location and you should perform the next step of the troubleshooting tree.*

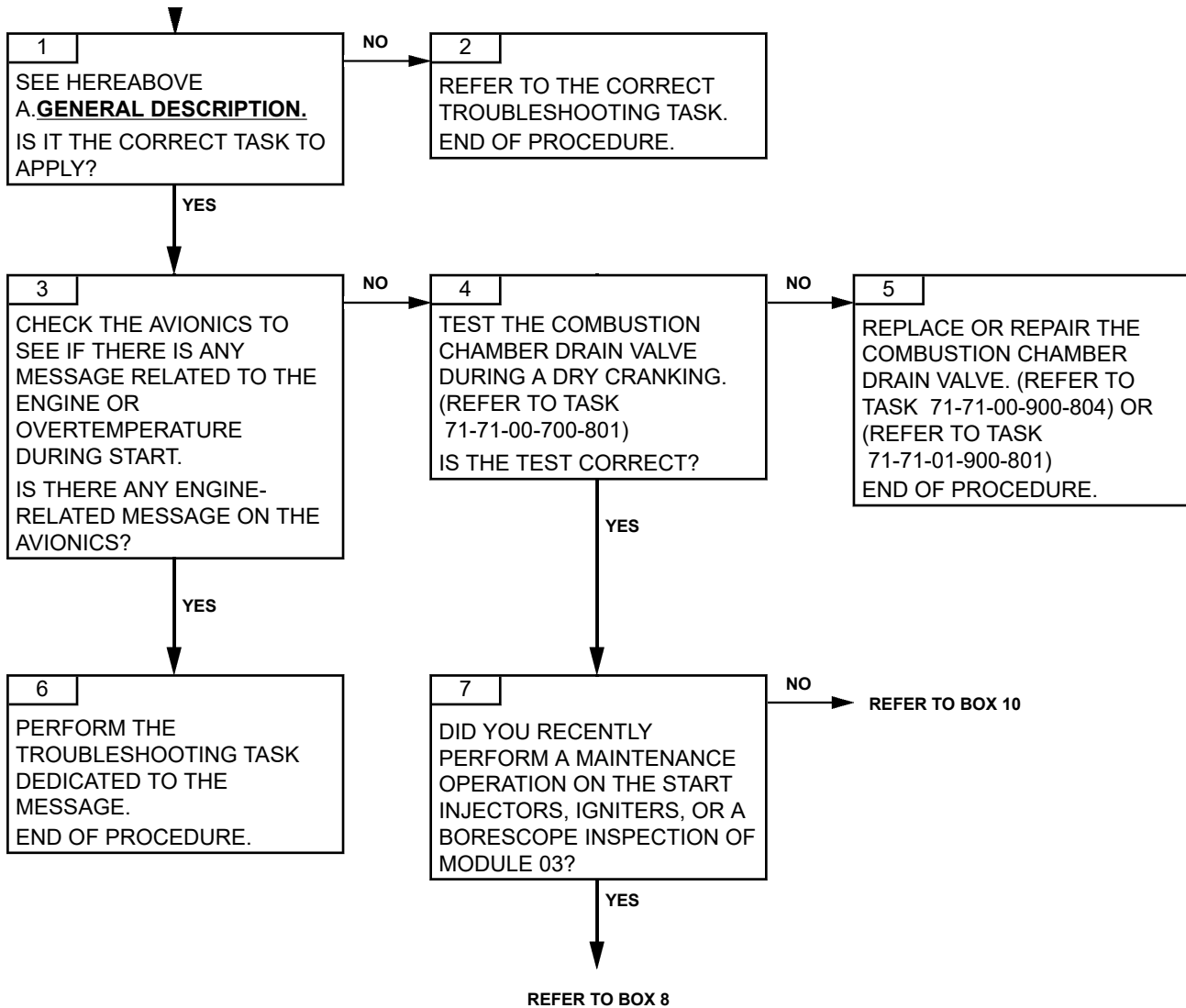

ARRIEL 2 C1

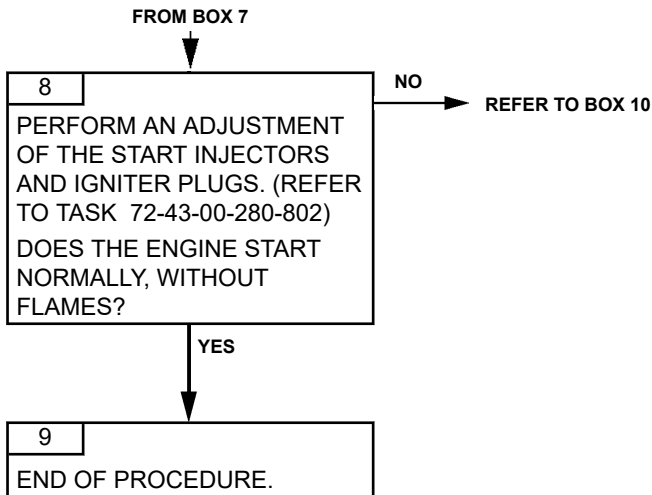

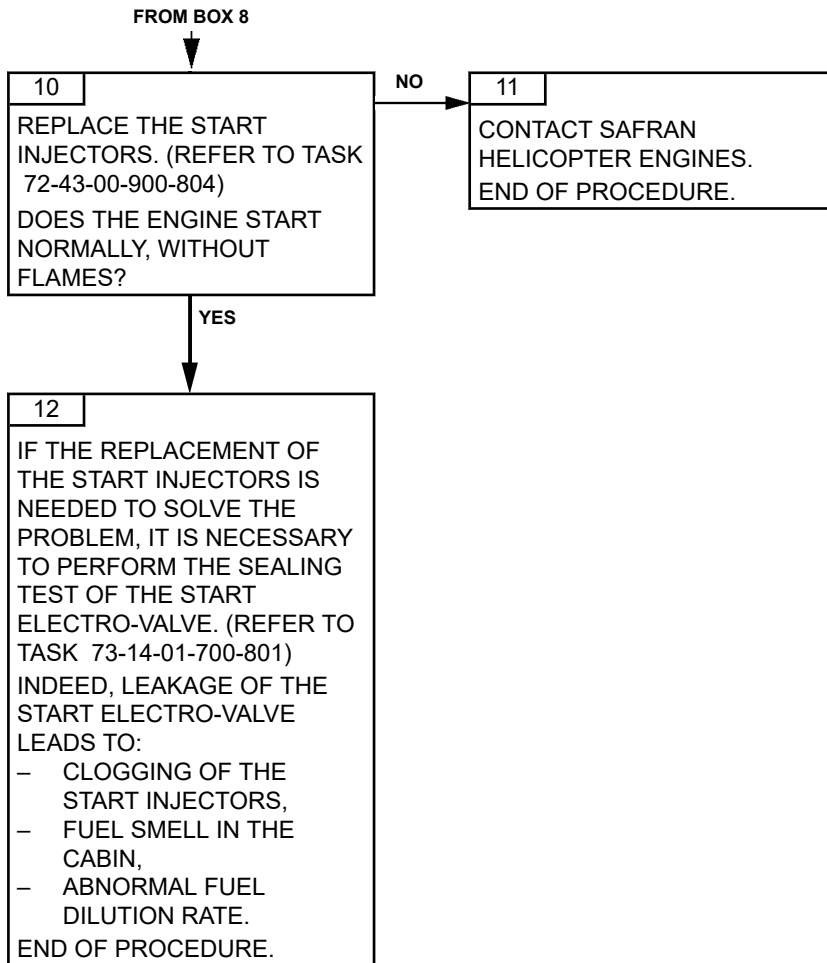

ARRIEL 2 C1

TASK 71-00-06-812-813-A01

NO OIL PRESSURE RISE AT STARTING TROUBLESHOOTING

1. GENERAL

| A. GENERAL DESCRIPTION

| In normal operation, at engine start, the oil pressure must rise.

| B. POSSIBLE CAUSES

- Oil pump
- Control and monitoring harness
- Aircraft (oil pressure transmitter, harnesses, indication)

2. PROCEDURE

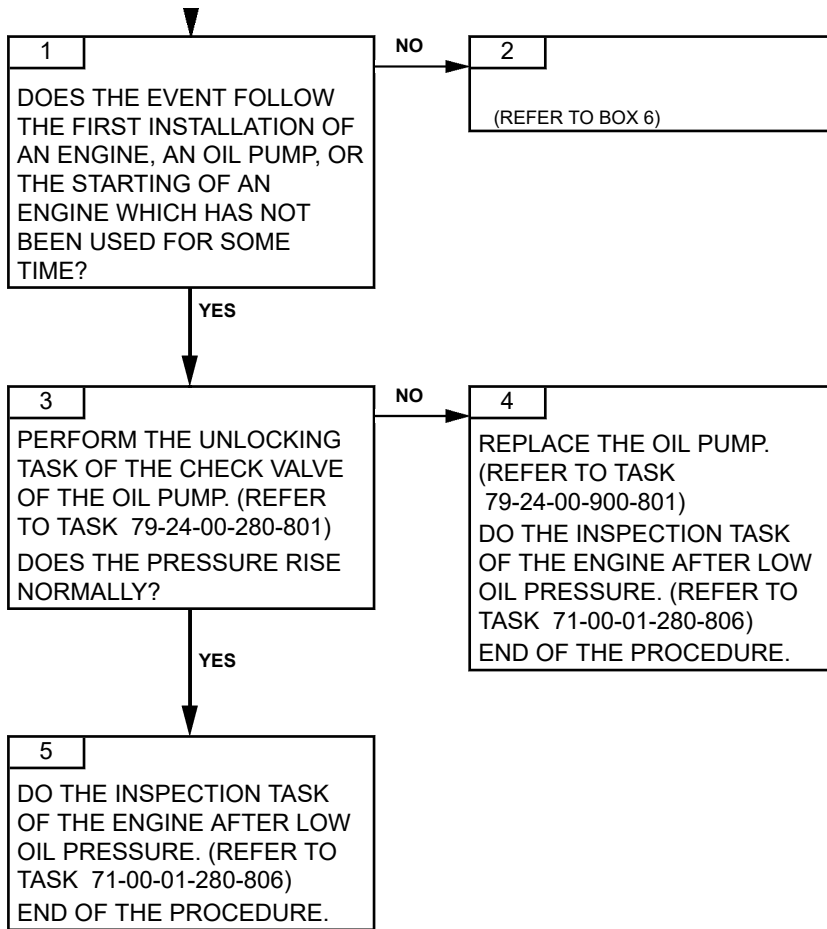

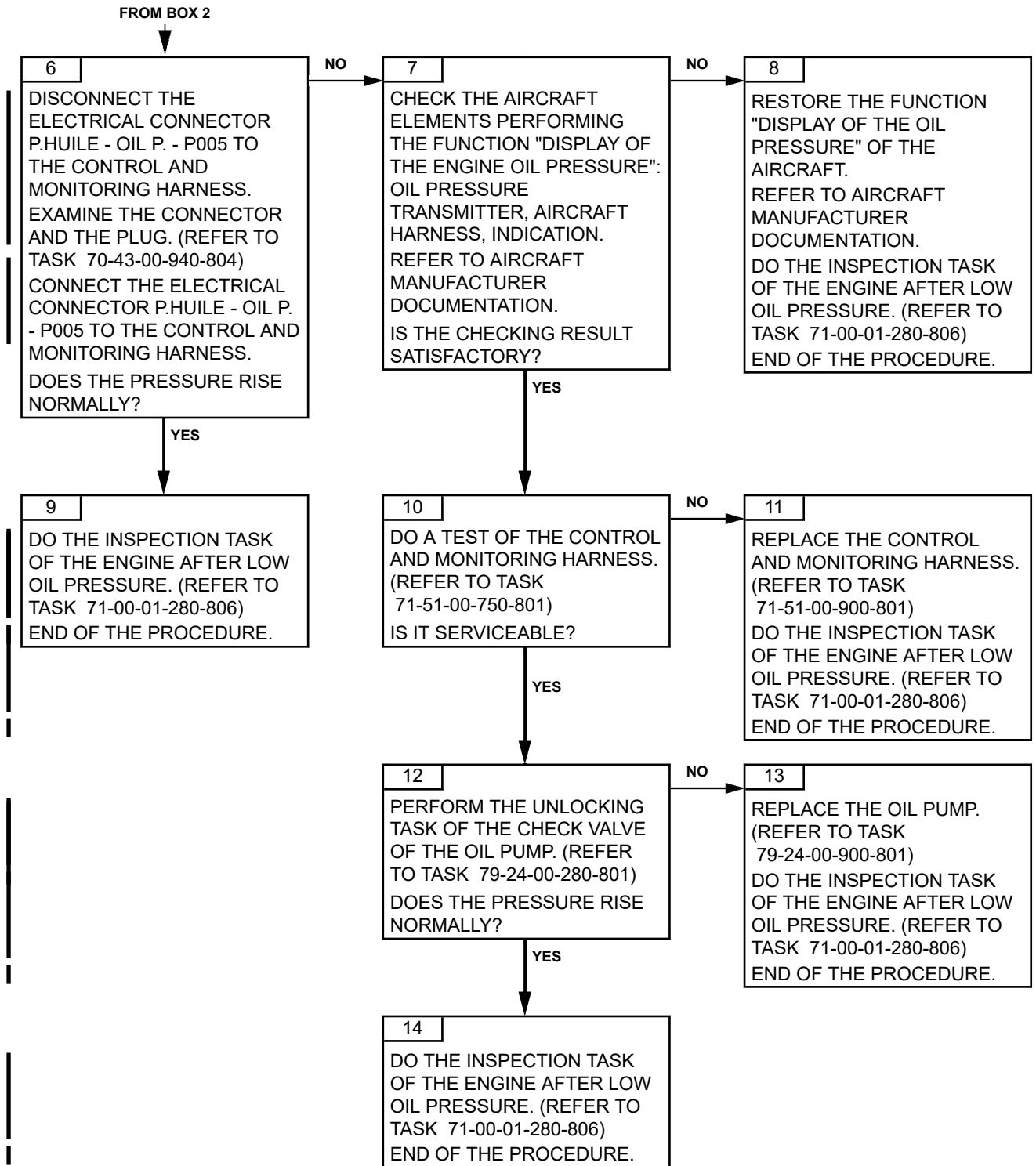

PAGE LEFT BLANK INTENTIONALLY

ARRIEL 2 C1

TASK 71-00-06-812-816-A01

**HELICOPTER ROTOR MOVEMENT THAT OCCURS
AFTER THE USUAL TIME DURING ENGINE START
TROUBLESHOOTING****1. GENERAL****A. PHASE AND FAILURE DETECTION**

<i>PHASE</i>	<i>INDICATION</i>	
	<i>ALARMS VEMD</i>	<i>WARNING INDICATOR LIGHTS</i>
Start		

**B. REMINDER OF THE NORMAL OPERATING CONDITION OR FAILURE
DETECTION**

- Refer to the rotor movement criteria in the Flight Manual (chapter "Engine starting")

C. POSSIBLE CAUSES

- Signs of rub of the PT blade tip against the PT shroud (M04)
- Free wheel assembly - sliding
- Labyrinth ring

2. PROCEDURE

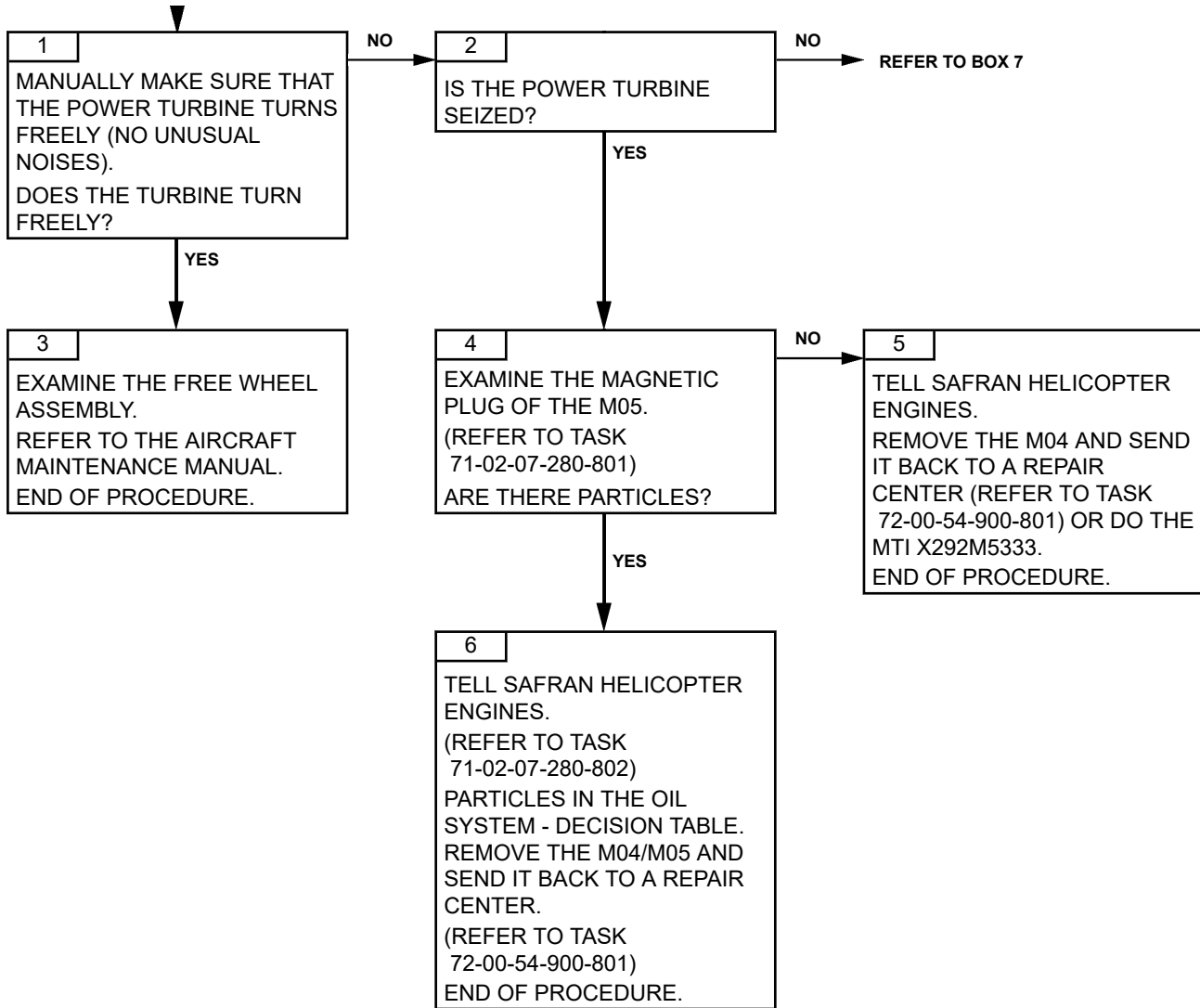

ARRIEL 2 C1

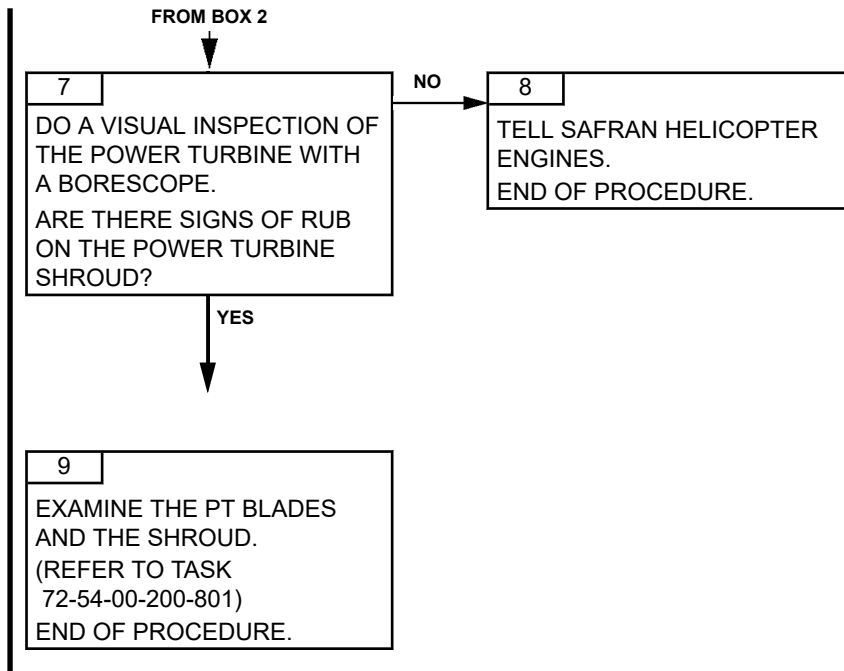

PAGE LEFT BLANK INTENTIONALLY

TASK 71-00-06-813-801-A01

**SURGE
TROUBLESHOOTING****1. GENERAL****A. GENERAL DESCRIPTION**

The engine surge is an abnormal phenomenon.

It is important to understand and to treat the root cause before treating the engine after surge.

B. POSSIBLE CAUSES

- Air intake
- Bleed valve

2. PROCEDURE

NOTE: *First, the fault isolation procedure helps you to find the root cause and to repair the engine part related to that root cause. After that, the troubleshooting procedure gives the checks and repairs of the event consequences on the engine.*

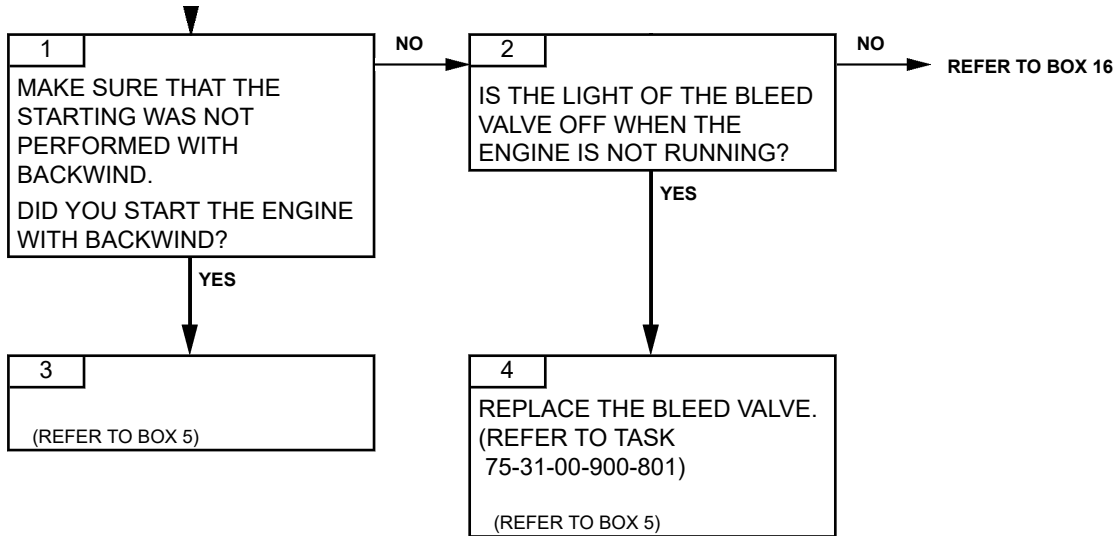

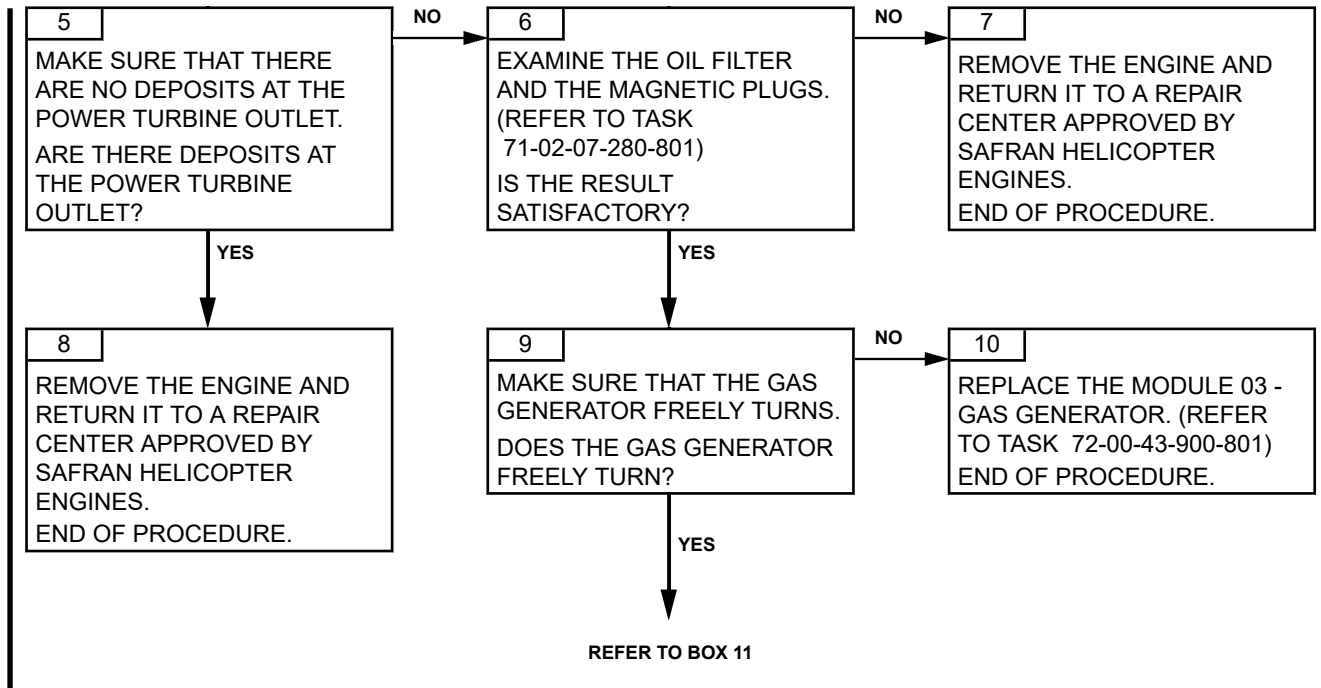

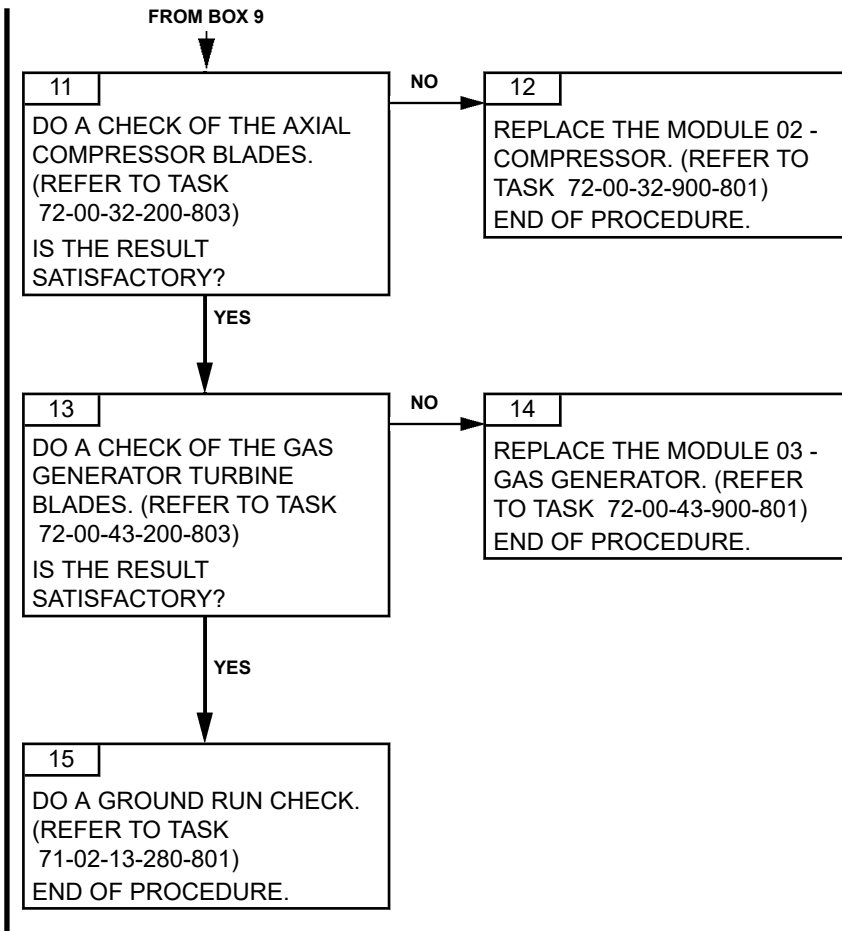

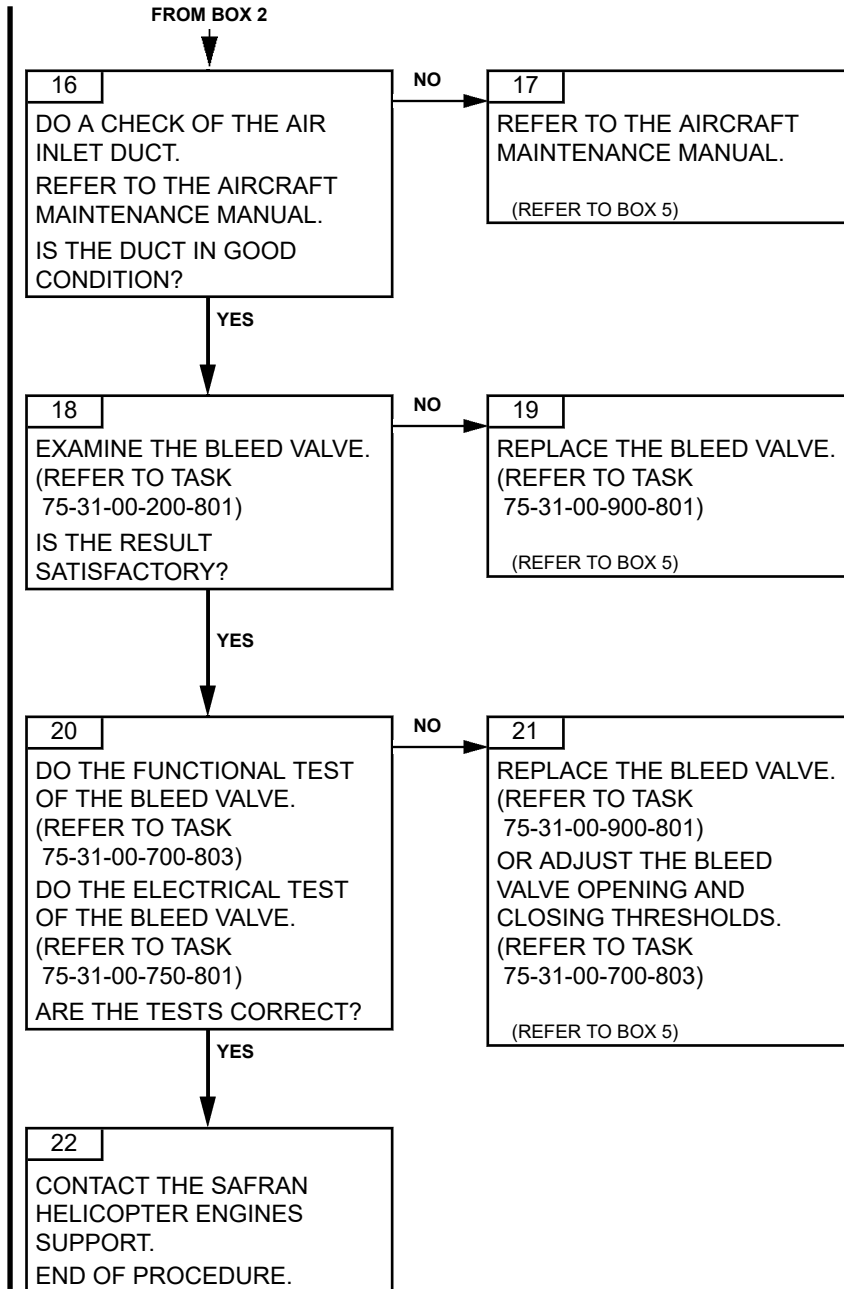

PAGE LEFT BLANK INTENTIONALLY

TASK 71-00-06-814-801-A01

ENG CHIP ON - INDICATOR LIGHT OF THE ELECTRICAL MAGNETIC PLUG ON TROUBLESHOOTING**1. GENERAL****A. INDICATION ON THE AVIONICS**

<i>Phase</i>	<i>Indication</i>	
	<i>Alarms on the FAU</i>	<i>Warning lights</i>
ENGINE RUNNING		Amber CHIP 1 or CHIP 2

B. GENERAL DESCRIPTION

During operation, the amber CHIP 1 and CHIP 2 messages must not show. The use of the particle burners must not have switched them off.

C. POSSIBLE CAUSES

- Engines modules
- Electrical magnetic plug
- Control and monitoring harness
- Aircraft

2. PROCEDURE

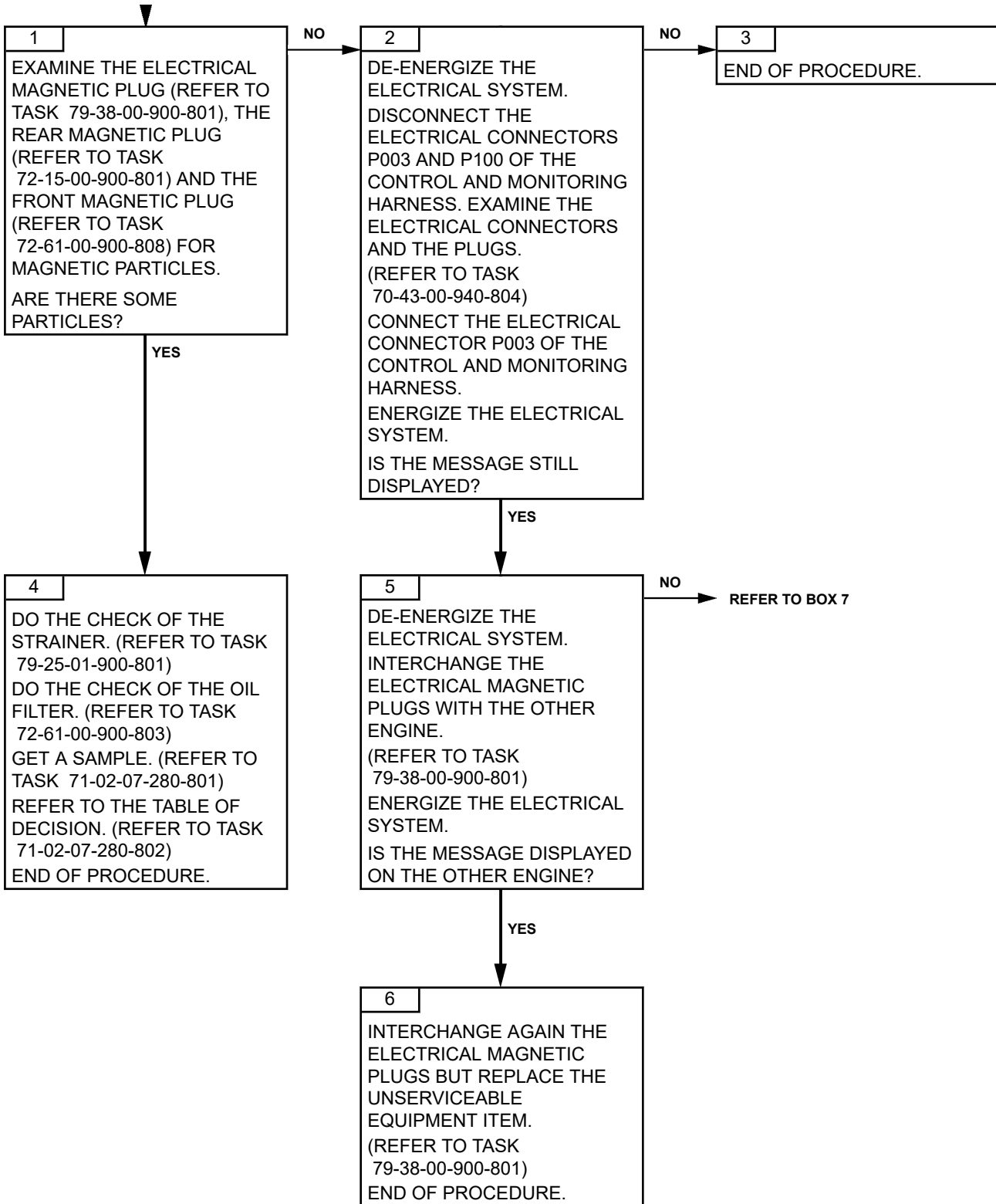

ARRIEL 2 C1

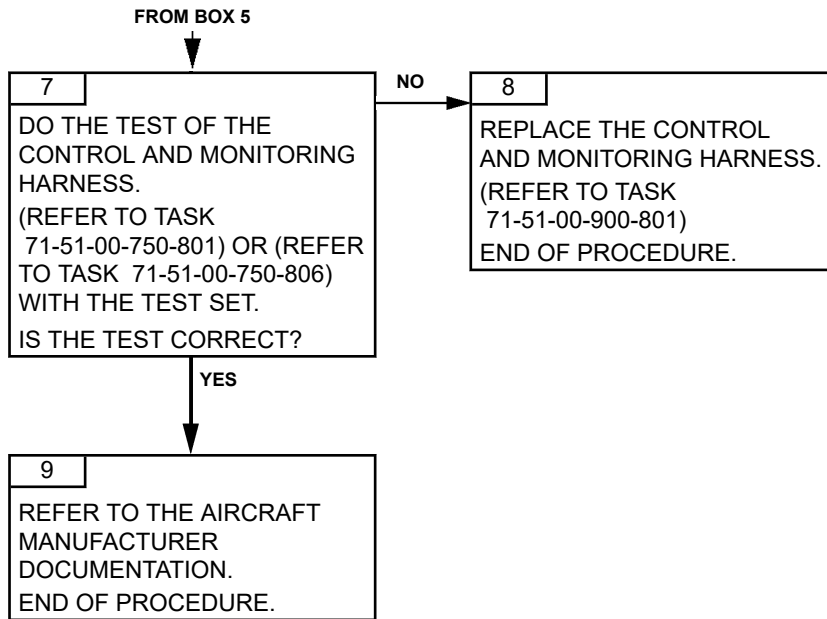

PAGE LEFT BLANK INTENTIONALLY

TASK 71-00-06-814-801-B01

ENG CHIP ON - INDICATOR LIGHT OF THE ELECTRICAL MAGNETIC PLUG ON TROUBLESHOOTING

1. GENERAL

A. INDICATION ON THE AVIONICS

<i>Phase</i>	<i>Indication</i>	
	<i>Alarms VEMD</i>	<i>Warning indicator lights</i>
ENGINE RUNNING		Amber ENG CHIP

B. GENERAL DESCRIPTION

During operation, the amber ENG CHIP messages must not show. The use of the particle burner must not have switched them off.

C. POSSIBLE CAUSES

- Modules M01, M02, M03, M04, M05
- Electrical magnetic plugs
- Control and monitoring harness
- Magnetic plug harness

2. PROCEDURE

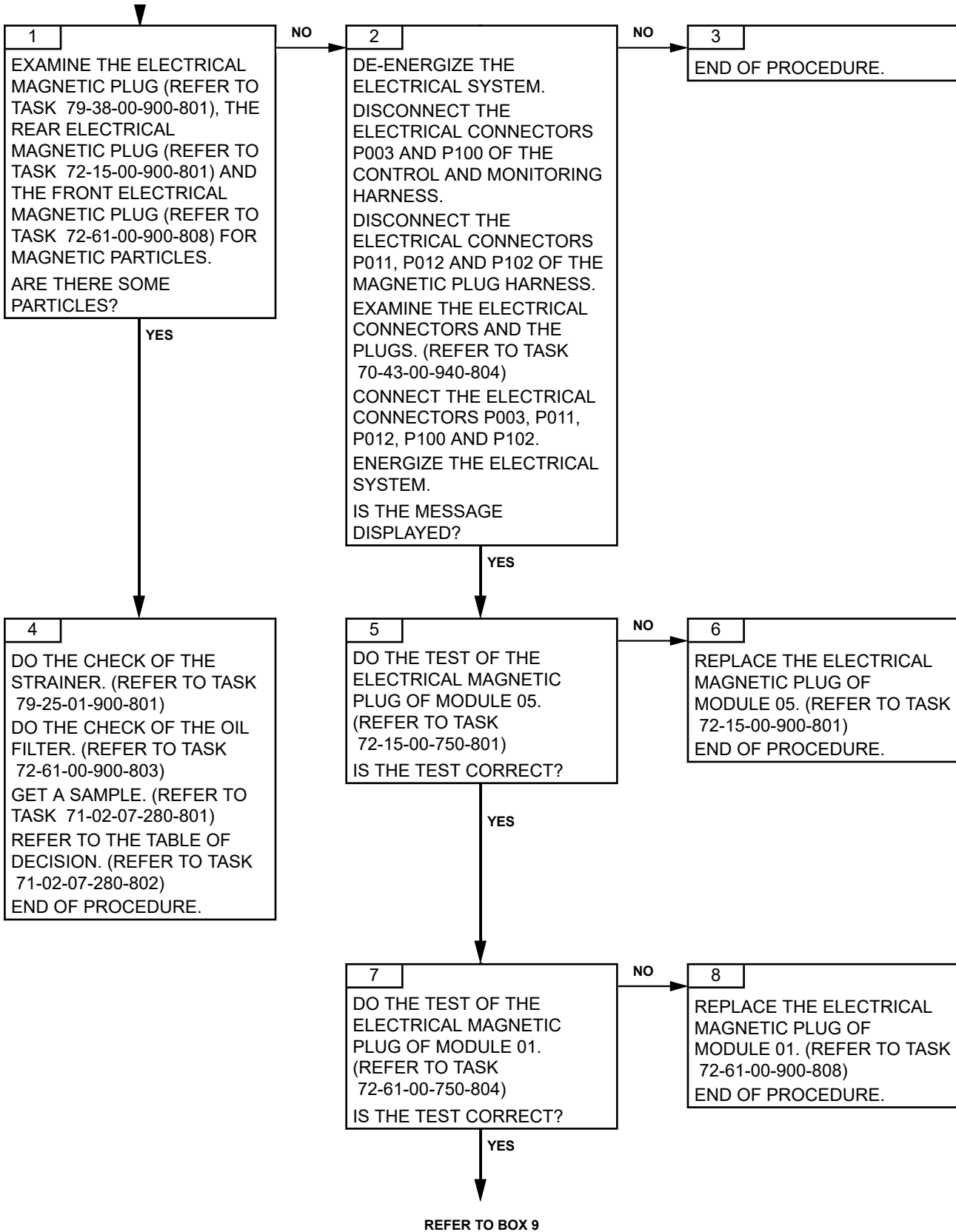

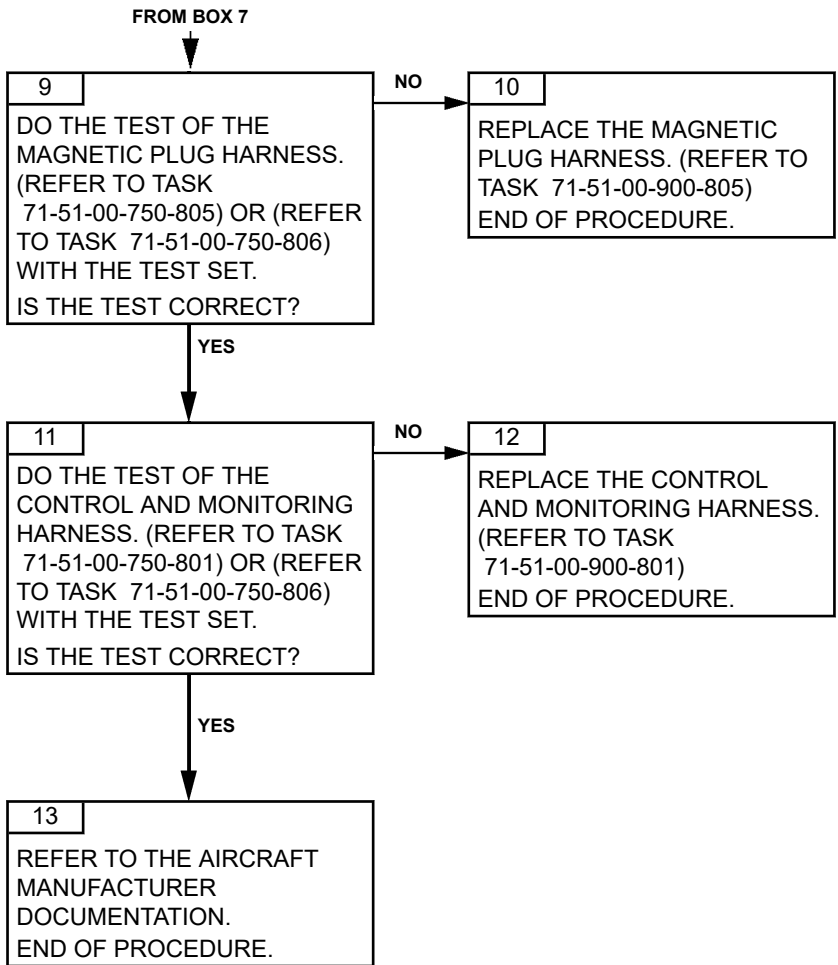

PAGE LEFT BLANK INTENTIONALLY

ARRIEL 2 C1

TASK 71-00-06-814-802-A01

**FUEL FILT ON - PRE-BLOCKAGE SIGNAL OF THE
FUEL FILTERING ELEMENT
TROUBLESHOOTING****1. GENERAL****A. PHASE AND FAILURE DETECTION**

<i>Phase</i>	<i>Indication</i>	
	<i>Alarms VEMD</i>	<i>Warning indicator lights</i>
ENGINE RUNNING		FUEL + FILT

B. GENERAL DESCRIPTION

The engine is equipped of:

- one fuel filter pre-blockage pressure switch connected to the aircraft.
- one red fuel filter mechanical blockage indicator.

C. POSSIBLE CAUSES

- Pre-blockage pressure switch of the fuel filter
- Control and monitoring harness
- Visual blockage indicator of the fuel filter
- Fuel contamination.

2. PROCEDURE

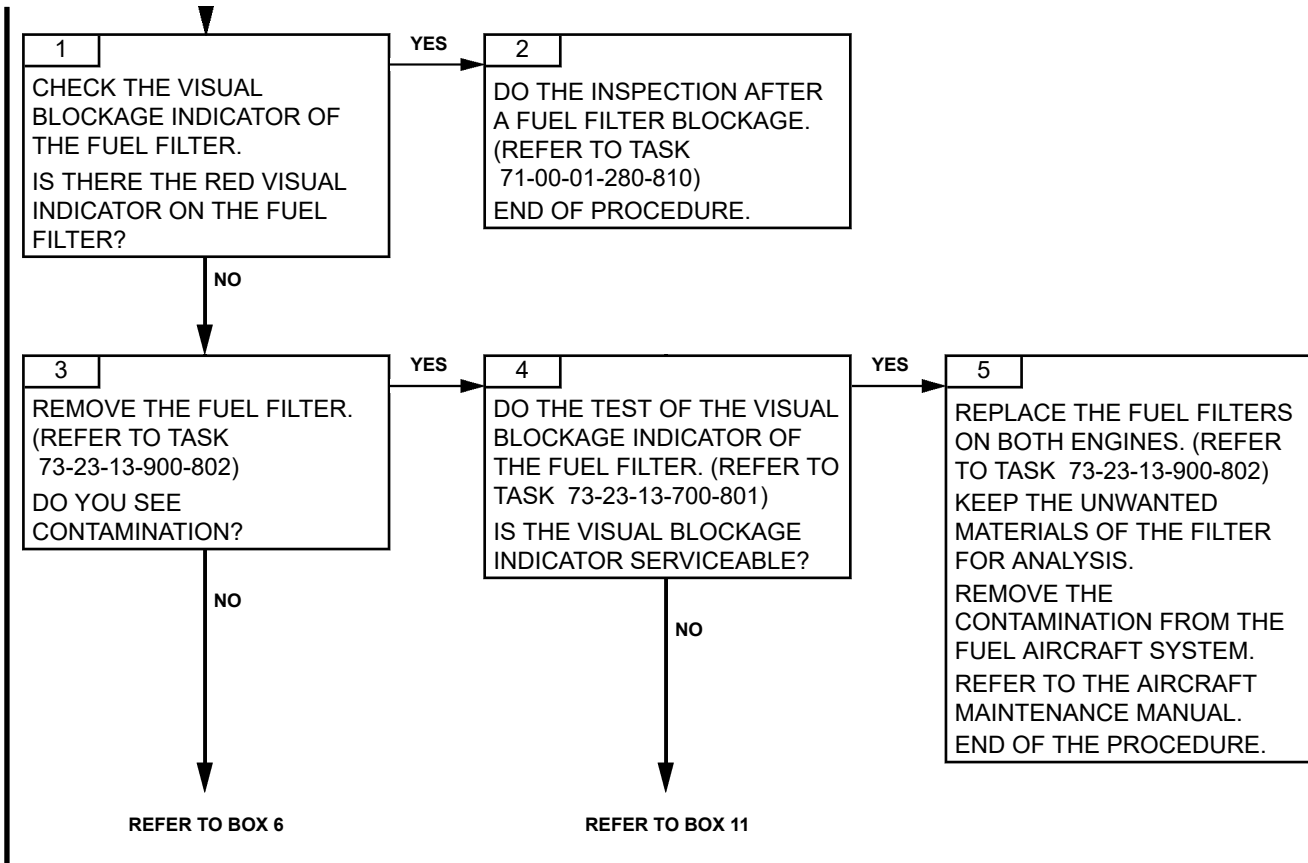

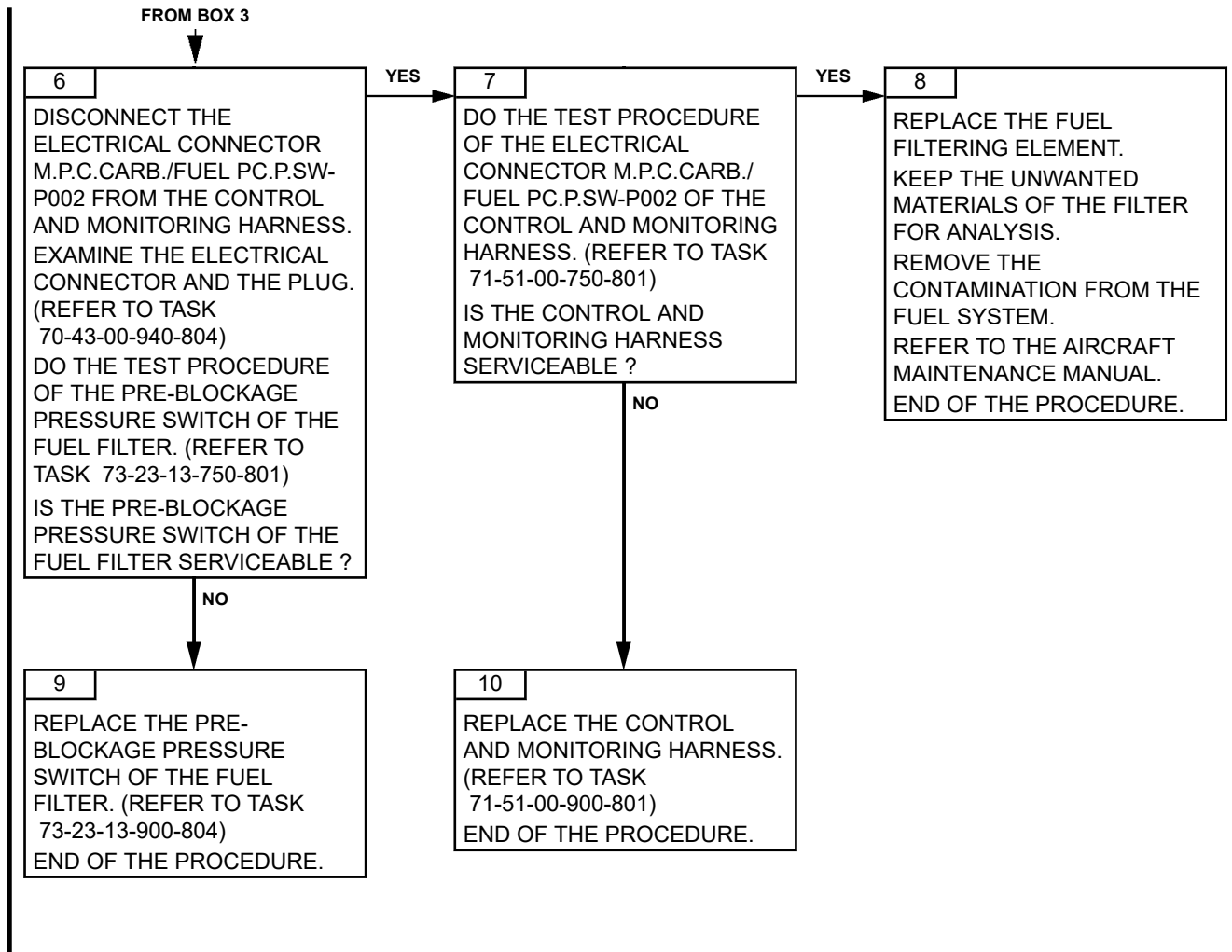

FROM BOX 4



11

DO THE INSPECTION AFTER
A FUEL FILTER BLOCKAGE.
(REFER TO TASK
71-00-01-280-810)
END OF PROCEDURE.

TASK 71-00-06-814-803-A01

FUEL P ON - LOW FUEL PRESSURE SIGNAL TROUBLESHOOTING

1. GENERAL

A. PHASE AND FAILURE DETECTION

<i>Phase</i>	<i>Indication</i>	
	<i>Alarms VEMD</i>	<i>Warning lights</i>
ENGINE RUNNING		Fuel tank

B. REMINDER OF THE NORMAL OPERATING CONDITION

During operation, the low fuel pressure signal must be off.

C. POSSIBLE CAUSES

- Low-fuel pressure switch
- Control and monitoring harness
- Aircraft electrical harness
- Pump and metering unit assembly

2. PROCEDURE

TURBOMECA ARRIEL 2 C1

MAINTENANCE MANUAL

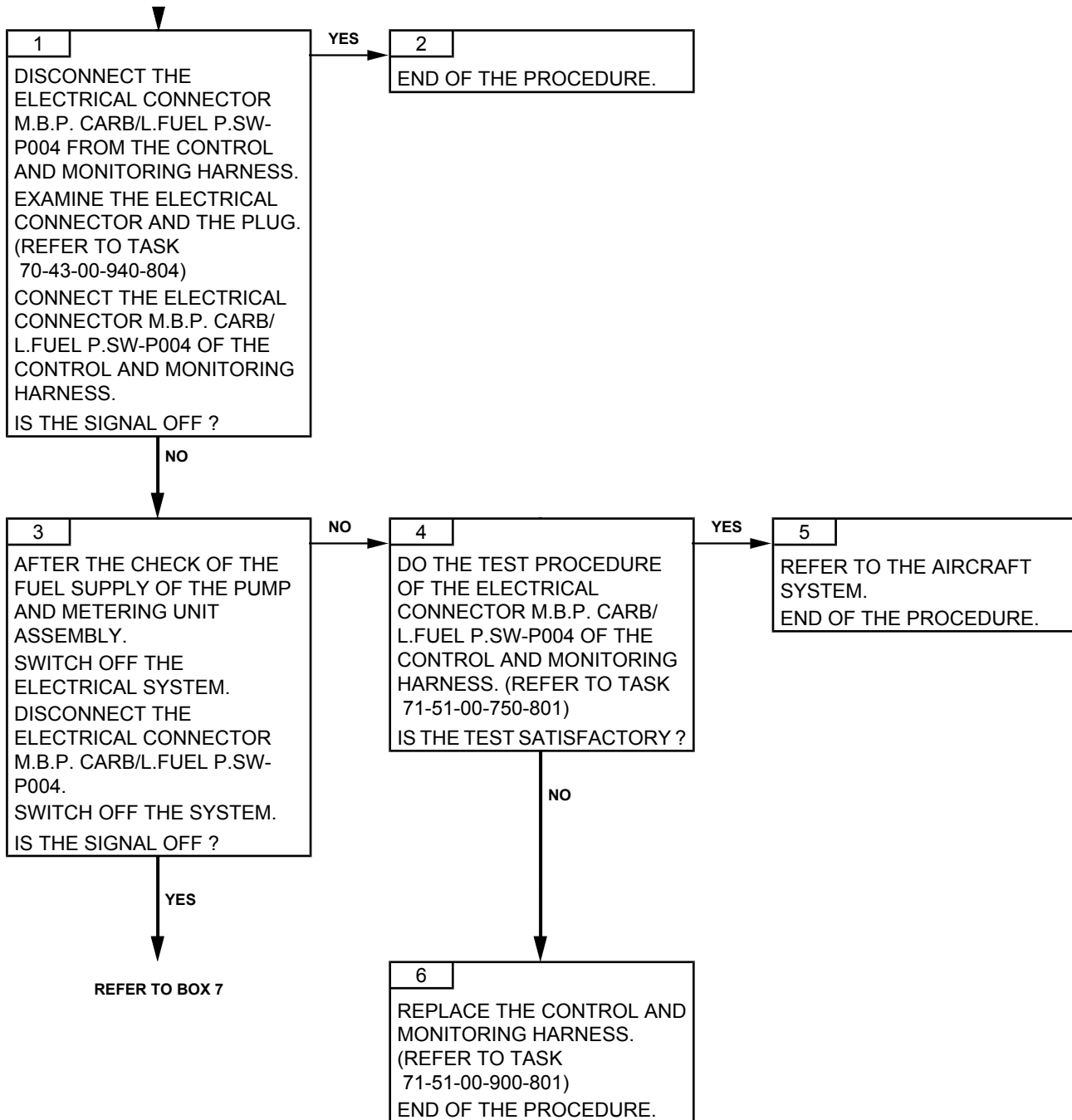

Effectivity: C1

Failures observed during engine operation

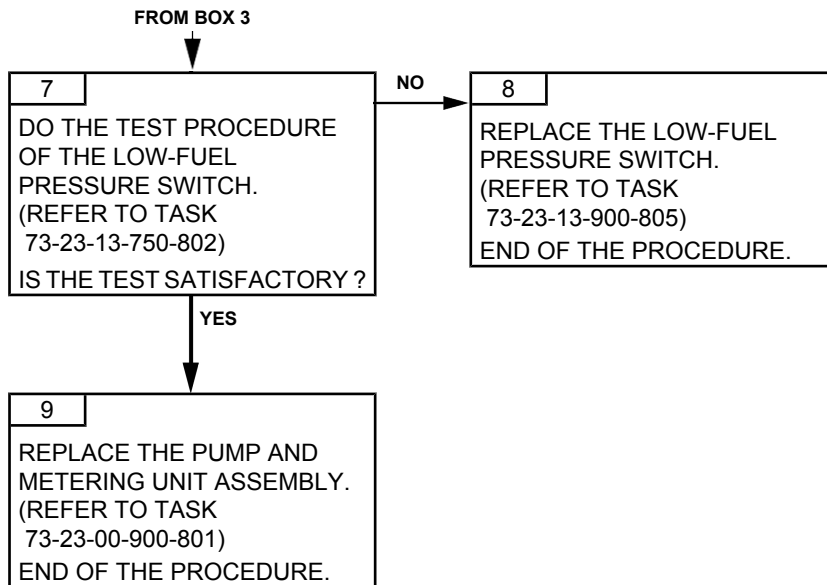

PAGE LEFT BLANK INTENTIONALLY

TASK 71-00-06-814-805-A01

ENGINE PARAMETER OUT OF LIMIT - TORQUE LIMITATIONS EXCEEDED TROUBLESHOOTING

1. GENERAL

A. PHASE AND FAILURE DETECTION

MH65D INDICATION		
Phase	Alarms VEMD	Warning indication lights
ENGINE RUNNING	Red flash under TRQ and Over Limit detected	

MH65E INDICATION			
Phase	MFD EICAS page	CDU TDL page	ECMS page
ENGINE RUNNING	Yellow ENG EXCEED		ENGINE QT

B. REMINDER OF THE NORMAL OPERATING CONDITION

Torque limitations exceeded (Refer to Task 71-00-01-940-801).

CAUTION: IF THE TORQUE LIMITATIONS ARE EXCEEDED, NOTE THE VALUE RECORDED IN THE OVER LIMIT DETECTED FUNCTION OF THE VEMD ON THE ENGINE LOG BOOK.

C. POSSIBLE CAUSES

- Module 01
- Module 03
- Module 04
- Module 05

NOTE: Make sure that the torque measurement system operates correctly; to do so, make sure that the messages below are not displayed on the VEMD: TRQ.A, TRQ.B, TRQ CL. A, TRQ CL. B.

2. PROCEDURE

Effectivity: C1

Failures observed during engine operation



1

DO THE PROCEDURE.
(REFER TO TASK
71-00-01-940-801 (SUB-TASK
71-00-01-940-015-A01))

TASK 71-00-06-814-806-A01

ENGINE PARAMETER OUT OF LIMIT - N1 LIMITATIONS EXCEEDED TROUBLESHOOTING

1. GENERAL

A. PHASE AND FAILURE DETECTION

<i>Phase</i>	<i>OTHER AVIONIC INDICATION</i>	
	<i>Alarms VEMD</i>	<i>Warning indicator lights</i>
ENGINE RUNNING	Flashing Red line under the N1 indication	

<i>Phase</i>	<i>MH65E INDICATION</i>		
	<i>MFD EICAS page</i>	<i>CDU TDL page</i>	<i>ECMS page</i>
ENGINE RUNNING	Yellow ENG EXCEED		ENGINE N1

B. REMINDER OF THE NORMAL OPERATING CONDITION

N1 limitations (Refer to Task 71-00-01-940-801).

C. POSSIBLE CAUSES

- Pump and metering Unit assembly
- N1 measurement system.

2. PROCEDURE

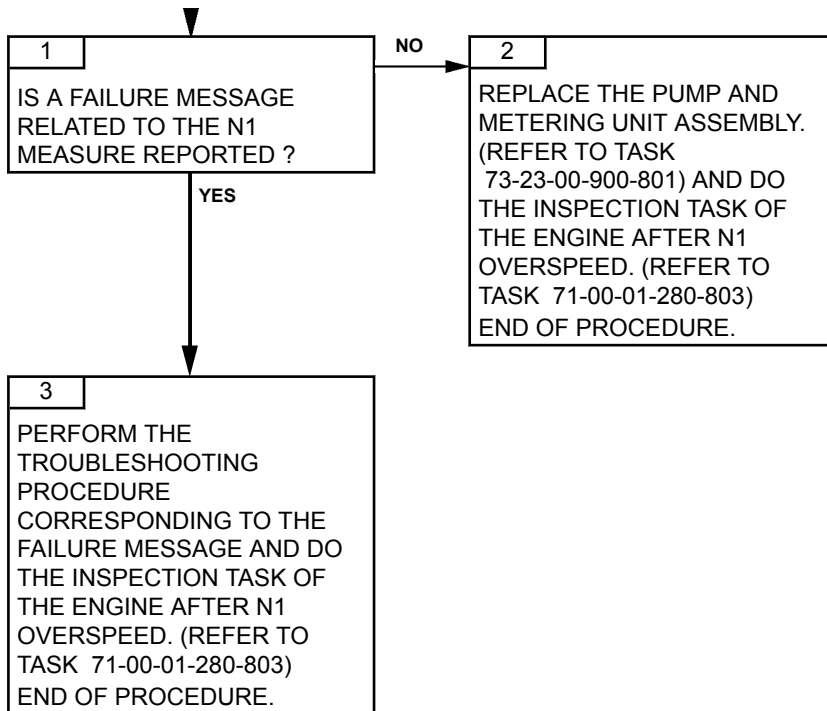

TASK 71-00-06-814-807-A01

ENGINE PARAMETER OUT OF LIMIT - N2 LIMITATIONS EXCEEDED TROUBLESHOOTING

1. GENERAL

A. PHASE AND FAILURE DETECTION

<i>Phase</i>	<i>OTHER AVIONIC INDICATION</i>	
	<i>Alarms VEMD</i>	<i>Warning indicator lights</i>
ENGINE RUNNING	Over Limit detected	NR/2 NTL indicator

<i>Phase</i>	<i>MH65E INDICATION</i>		
	<i>MFD EICAS page</i>	<i>CDU TDL page</i>	<i>ECMS page</i>
ENGINE RUNNING	Yellow ENG EXCEED		ENGINE N2

B. REMINDER OF THE NORMAL OPERATING CONDITION

N2 limitations (Refer to Task 71-00-01-940-801)

C. POSSIBLE CAUSES

- Pump and metering Unit assembly
- N2 measurement system.

2. PROCEDURE

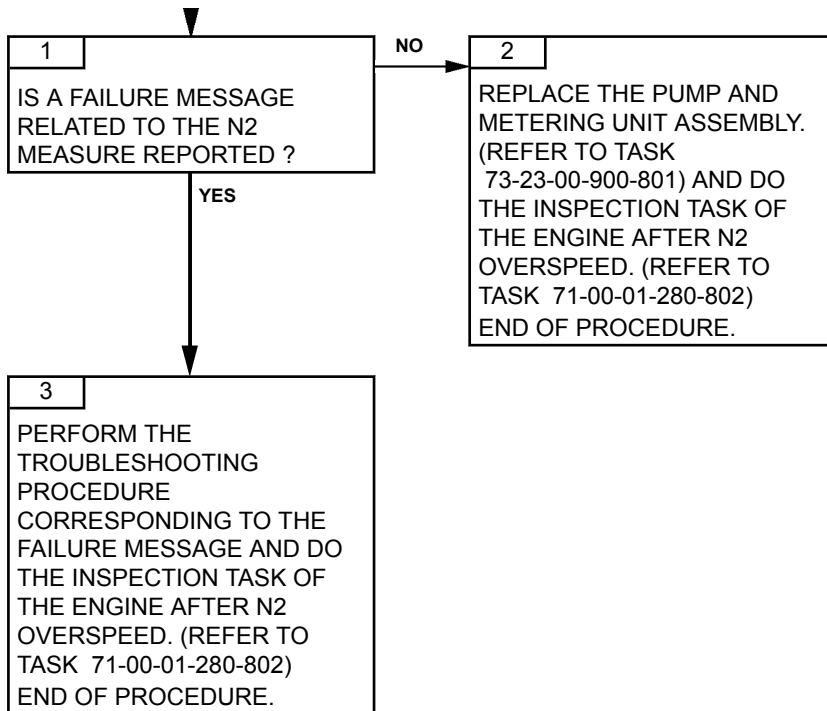

TASK 71-00-06-814-808-A01

PARAMETER INSTABILITY - OIL PRESSURE TROUBLESHOOTING

1. GENERAL

A. PHASE AND FAILURE DETECTION

<i>OTHER AVIONIC INDICATION</i>		
<i>Phase</i>	<i>Alarms VEMD</i>	<i>Warning indication lights</i>
ENGINE RUNNING	ENGINE OIL PRESSURE indicator	

<i>MH65E INDICATION</i>			
<i>Phase</i>	<i>MFD EICAS page</i>	<i>CDU TDL page</i>	<i>ECMS page</i>
ENGINE RUNNING	ENGINE OIL PRESSURE indicator	N/A	N/A

B. FAILURE DETECTION CONDITIONS

Evolution of the oil pressure during the flight.

C. POSSIBLE CAUSES

- Leakage
- Oil system contamination
- Oil pump
- Reduction gearbox module (M05)

2. PROCEDURE

Effectivity: C1

Failures observed during engine operation

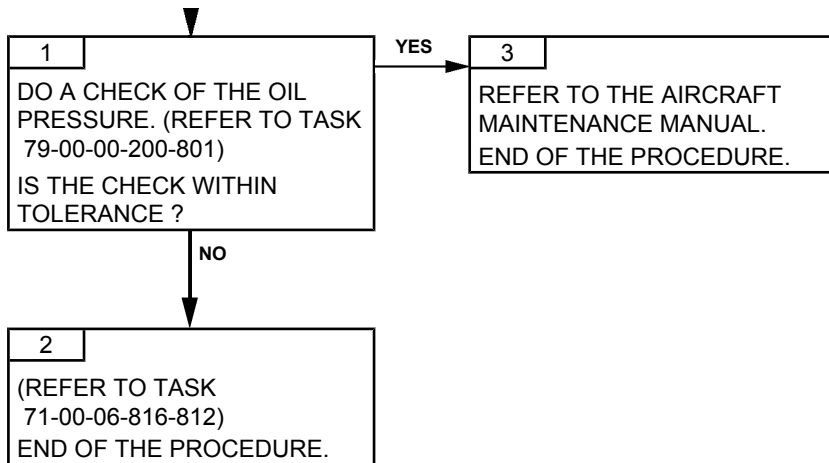

TASK 71-00-06-814-809-A01

ENG P ON - LOW OIL PRESSURE SIGNAL TROUBLESHOOTING

1. GENERAL

A. PHASE AND FAILURE DETECTION

<i>Phase</i>	<i>Indication</i>	
	<i>Alarms VEMD</i>	<i>Warning indicator lights</i>
ENGINE RUNNING		Red ENG 1 or ENG 2 on

B. REMINDER OF THE NORMAL OPERATING CONDITION

During operation, the ENG 1 or ENG 2 light must be off for an oil pressure $P > 130$ kPa (18.9 PSI).

C. POSSIBLE CAUSES

- Low-oil pressure switch
- Control and monitoring harness

2. PROCEDURE

TURBOMECA ARRIEL 2 C1

MAINTENANCE MANUAL

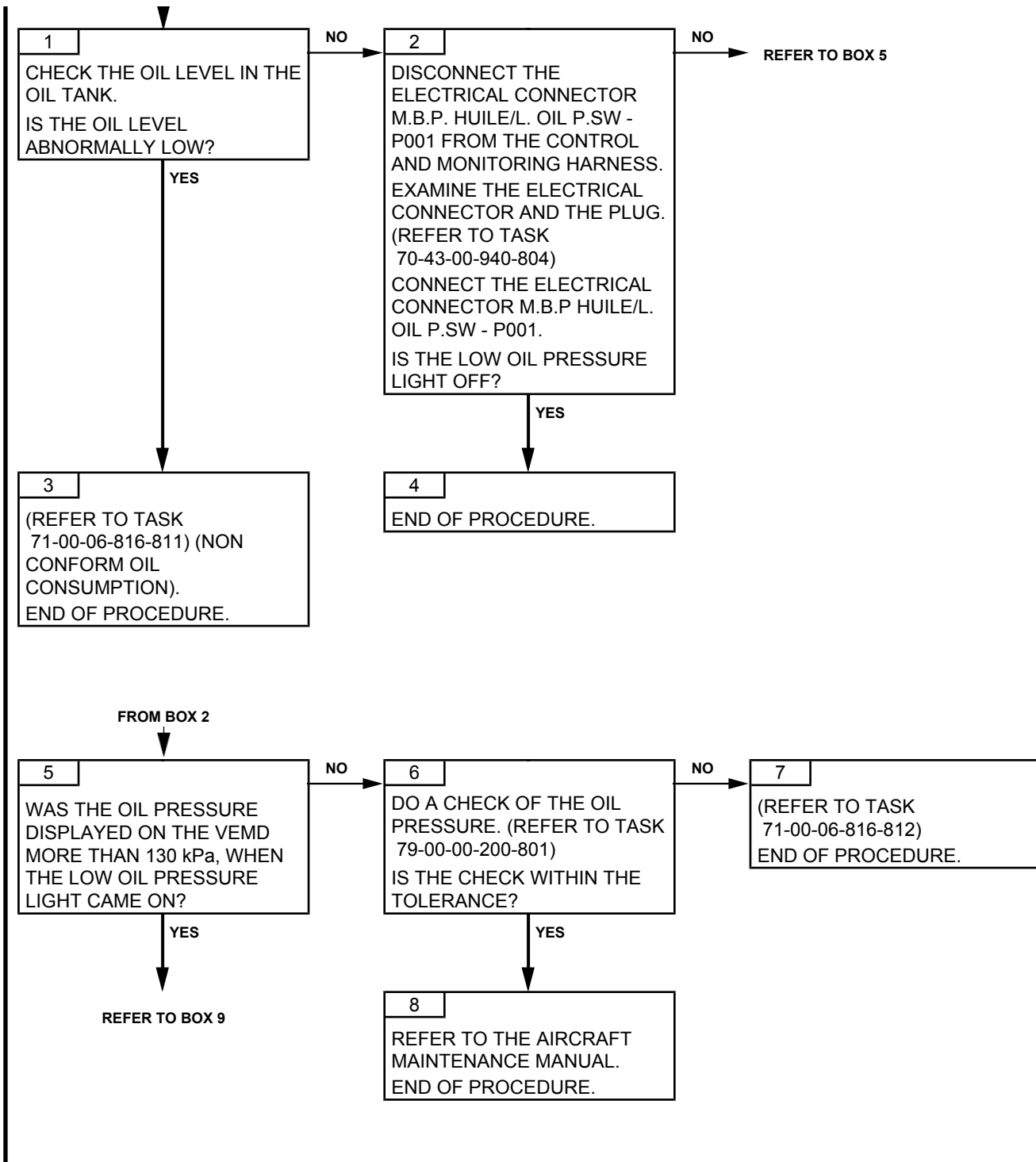

Effectivity: C1

Failures observed during engine operation

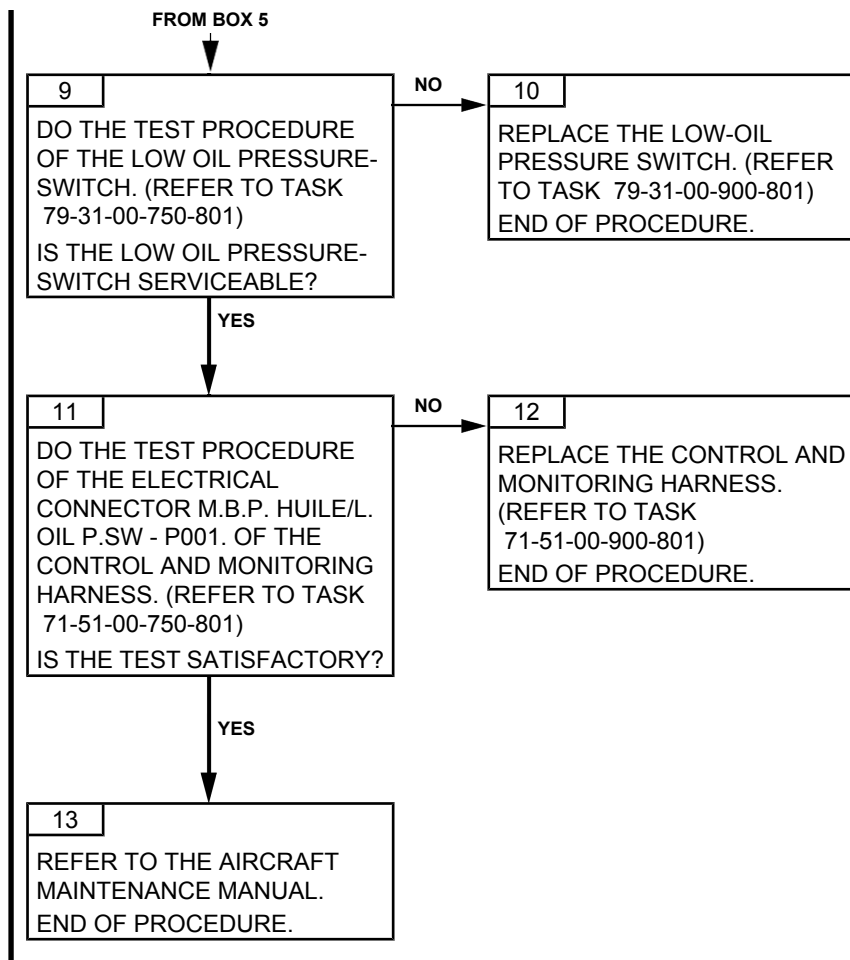

PAGE LEFT BLANK INTENTIONALLY

TASK 71-00-06-814-810-A01

ENGINE PARAMETER OUT OF LIMIT - OIL OVERTEMPERATURE TROUBLESHOOTING

1. GENERAL

A. PHASE AND FAILURE DETECTION

<i>Phase</i>	<i>Indication</i>	
	<i>Alarms</i>	<i>Warning lights</i>
RUNNING		

B. REMINDER OF THE OPERATING NORMAL CONDITION OR FAILURE DETECTION

Refer to limitations. (Refer to Task 71-00-01-940-801)

C. POSSIBLE CAUSES

- Aircraft oil temperature measuring system
- Oil quantity
- Aircraft oil cooling system

2. PROCEDURE

TURBOMECA ARRIEL 2 C1

MAINTENANCE MANUAL

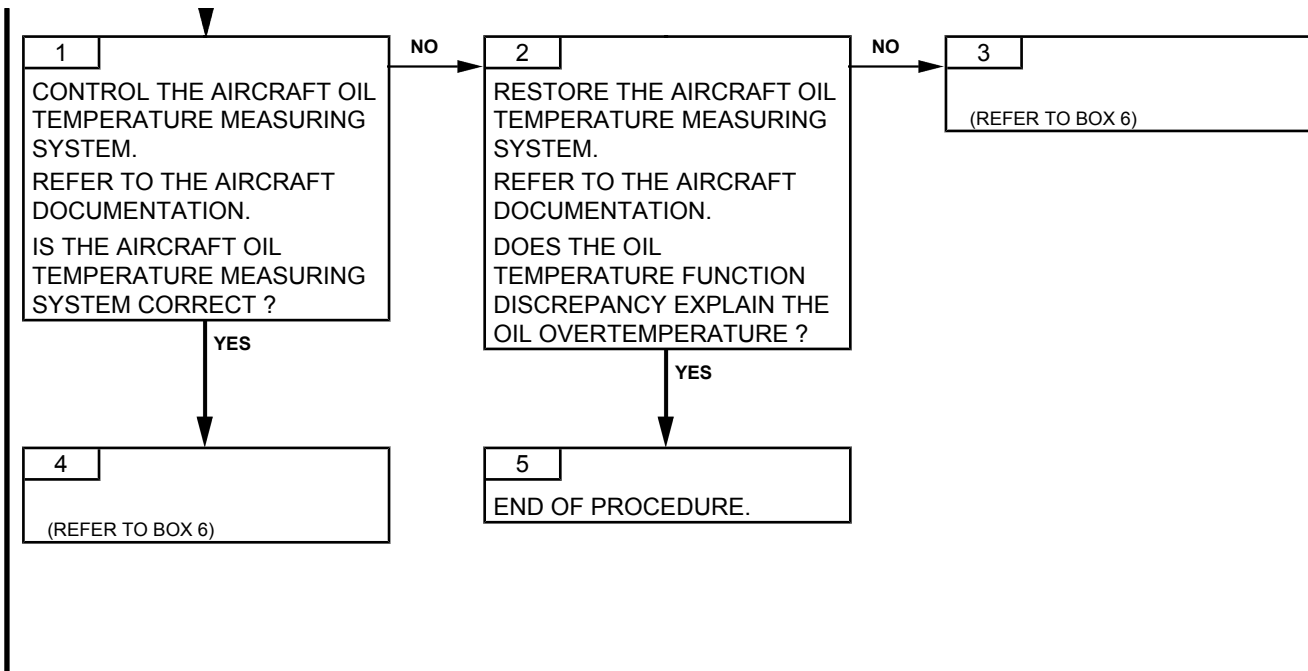

Effectivity: C1

Failures observed during engine operation

TURBOMECA ARRIEL 2 C1

MAINTENANCE MANUAL

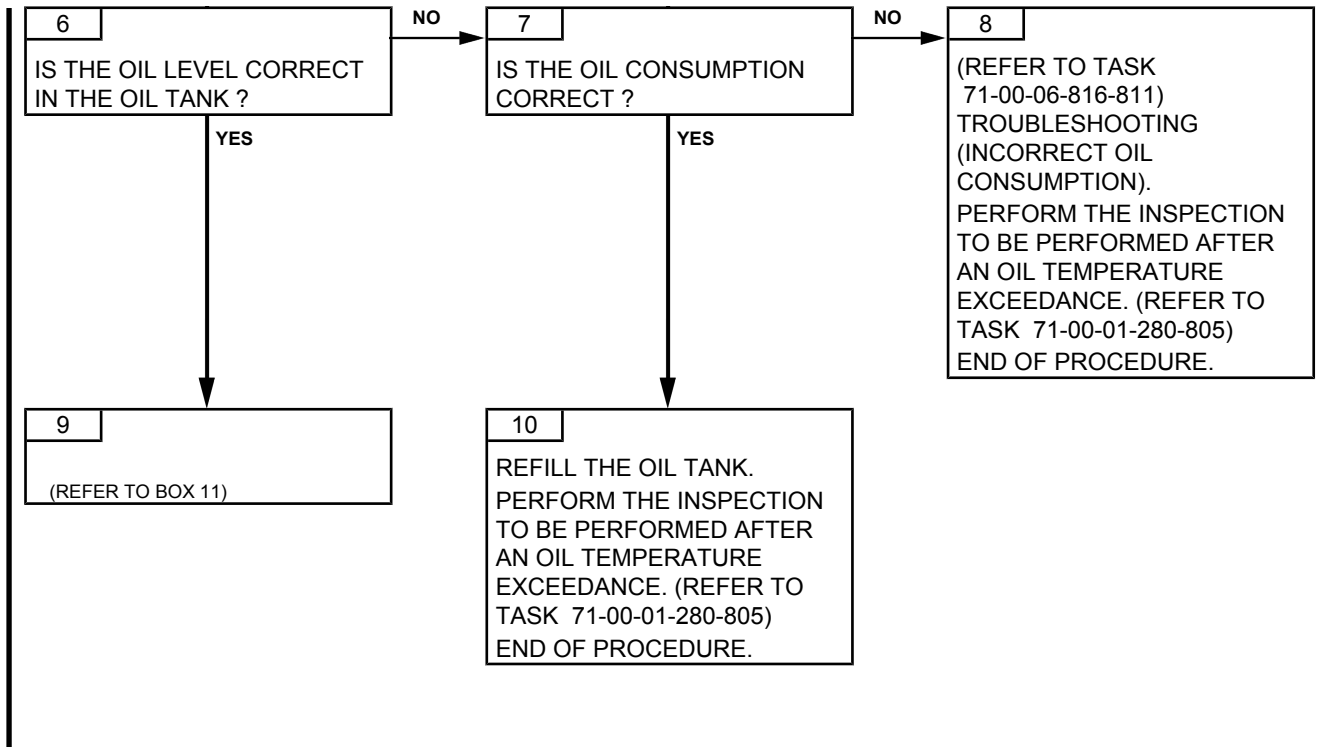

Effectivity: C1

Failures observed during engine operation

TURBOMECA ARRIEL 2 C1

MAINTENANCE MANUAL

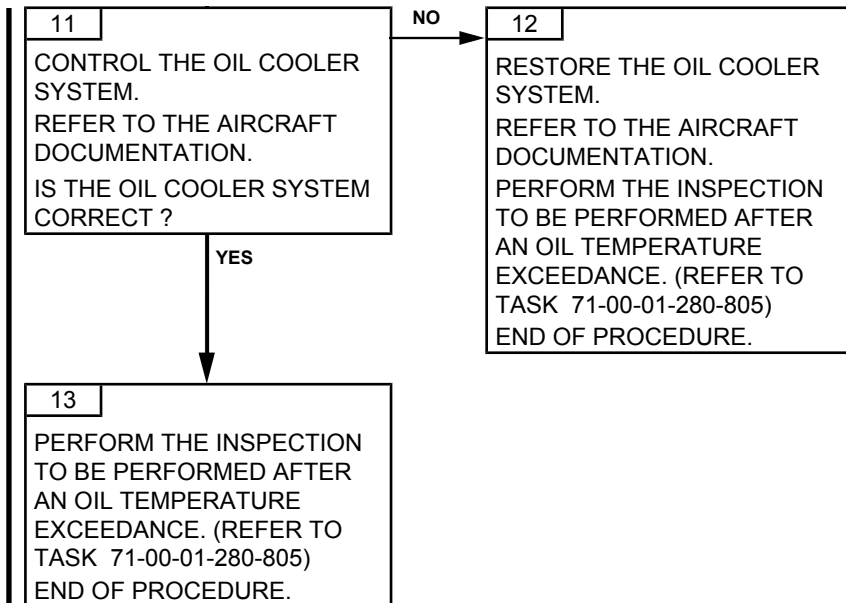

Effectivity: C1

Failures observed during engine operation

TASK 71-00-06-814-812-A01

PARAMETER INSTABILITY - TORQUE TROUBLESHOOTING

1. GENERAL

A. PHASE AND FAILURE DETECTION

Phase	OTHER AVIONIC INDICATION	
	Alarms VEMD	Warning indicator lights
ENGINE RUNNING	Torque "FLI" indication	

Phase	MH65E INDICATION		
	MFD EICAS page	CDU TDL page	ECMS page
ENGINE RUNNING	N/A	N/A	N/A

B. REMINDER OF THE NORMAL OPERATING CONDITION

Normal torque indication

C. POSSIBLE CAUSES

- Control harness
- Torquemeter shaft
- Torque conformation box
- Torque indication -IIDS - Aircraft manufacturer responsibility
- Torquemeter sensor
- DECU

NOTE: *Before proceeding with the troubleshooting, make sure that there is no failure message related to the torque measurement system on the avionic.*

2. PROCEDURE

▼
1

REPLACE THE MODULE 01.
(REFER TO TASK
72-00-61-900-801)
END OF THE PROCEDURE

TASK 71-00-06-815-801-A01

UNUSUAL NOISES DURING RUNDOWN PHASE
TROUBLESHOOTING1. **GENERAL**A. **PHASE AND FAILURE DETECTION**

Phase	OTHER AVIONIC INDICATION	
	Alarms VEMD	Warning indicator lights
SHUTDOWN	N/A	N/A

Phase	MH65E INDICATION		
	MFD EICAS page	CDU TDL page	ECMS page
SHUTDOWN	N/A	N/A	N/A

B. **REMINDER OF THE OPERATING NORMAL CONDITION**

At engine shutdown (after stabilization at 30-second idle rating).

C. **POSSIBLE CAUSES**

- Compressor module (M02)
- Starter
- Pump and metering unit assembly
- Alternator
- Oil pump
- Gas generator module (M03)
- Reduction gearbox module (M05)
- Power turbine module (M04)

2. **PROCEDURE**

NOTE: *It is necessary to check the permeability of the injection wheel so as to rule on the effectivity of the MTI X292M1308. This MTI makes it possible to clean or replace the injection manifold and to replace the HP turbine. It makes it possible to free from the full replacement of the module 03.*

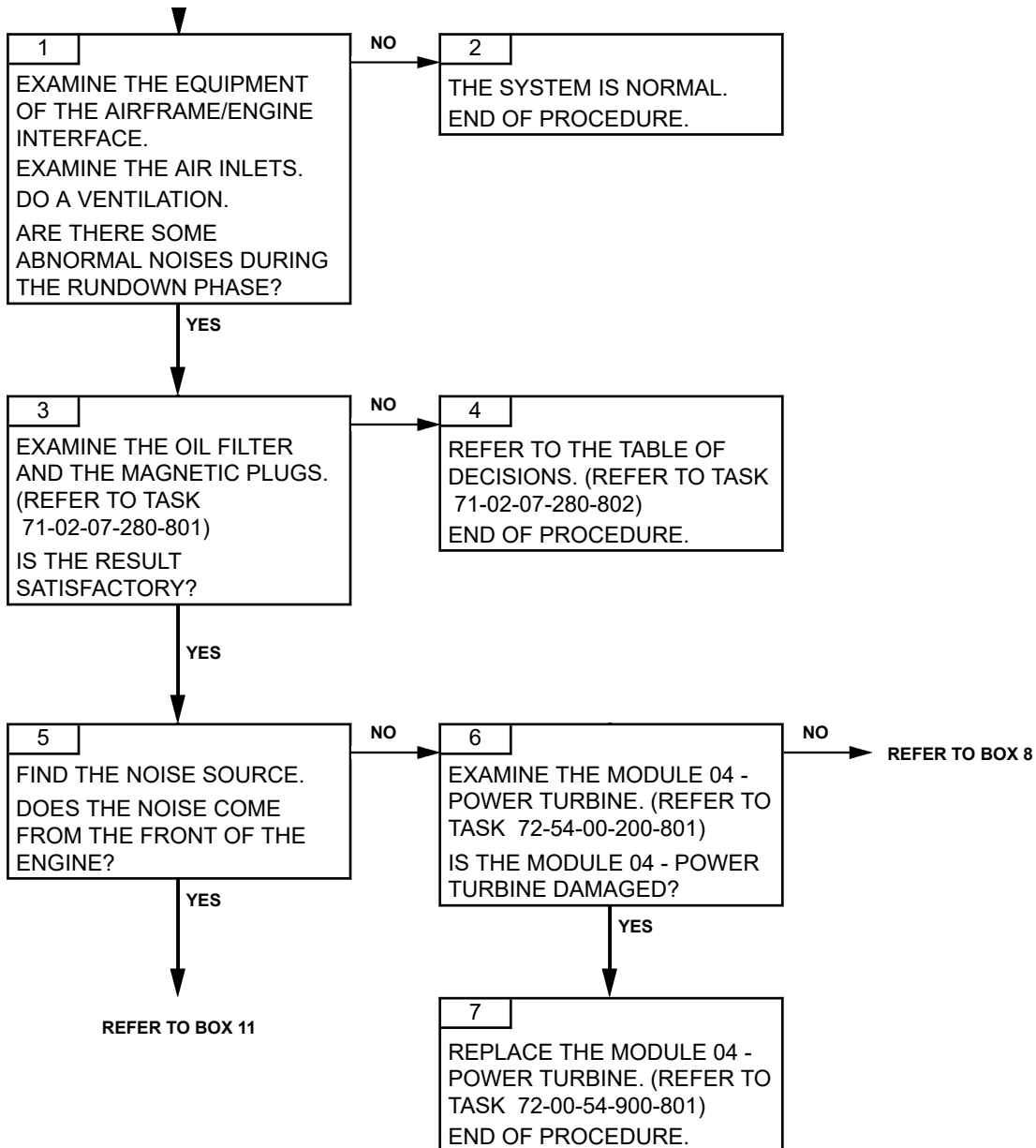

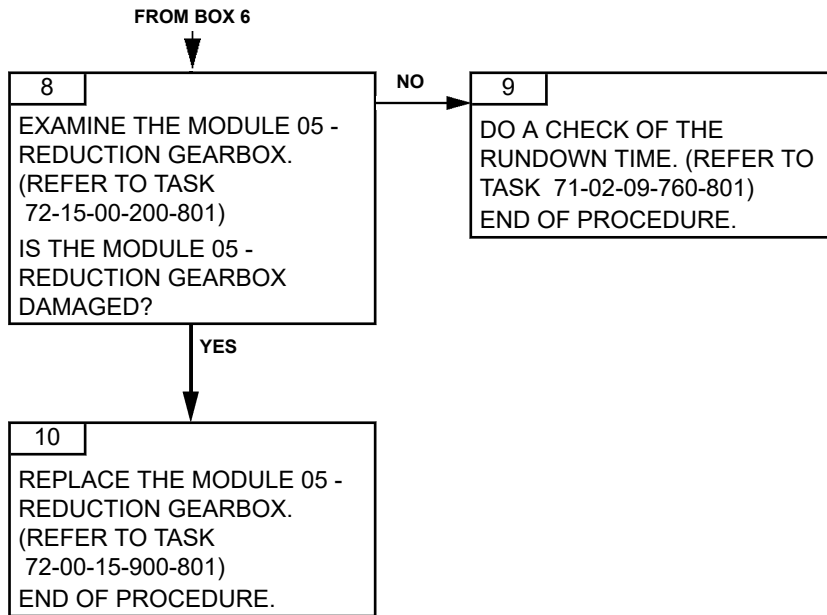

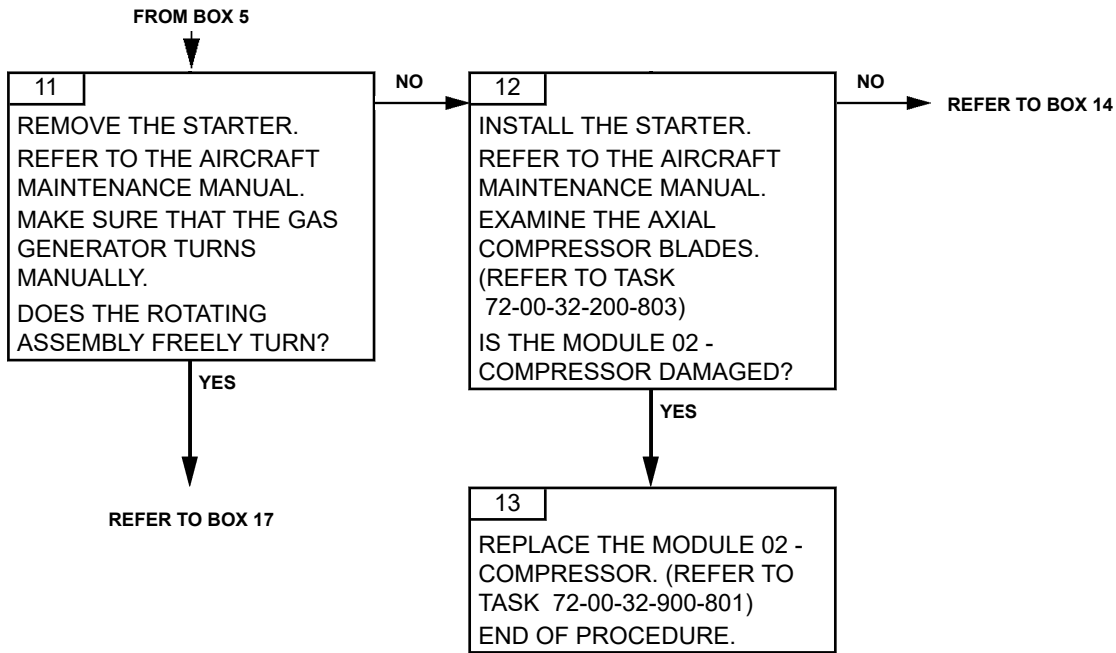

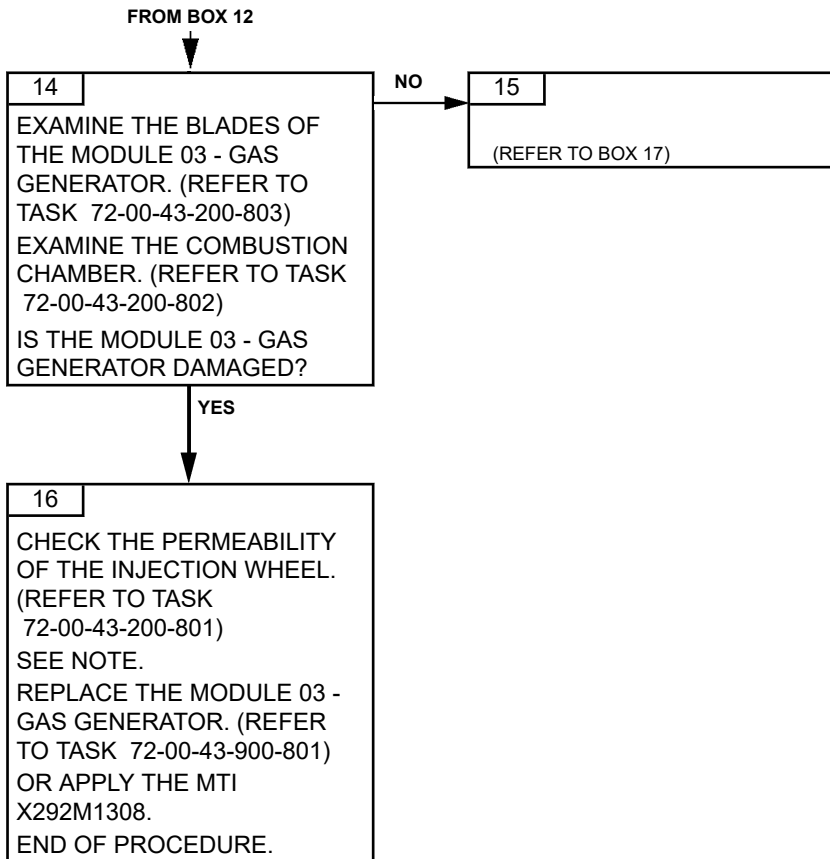

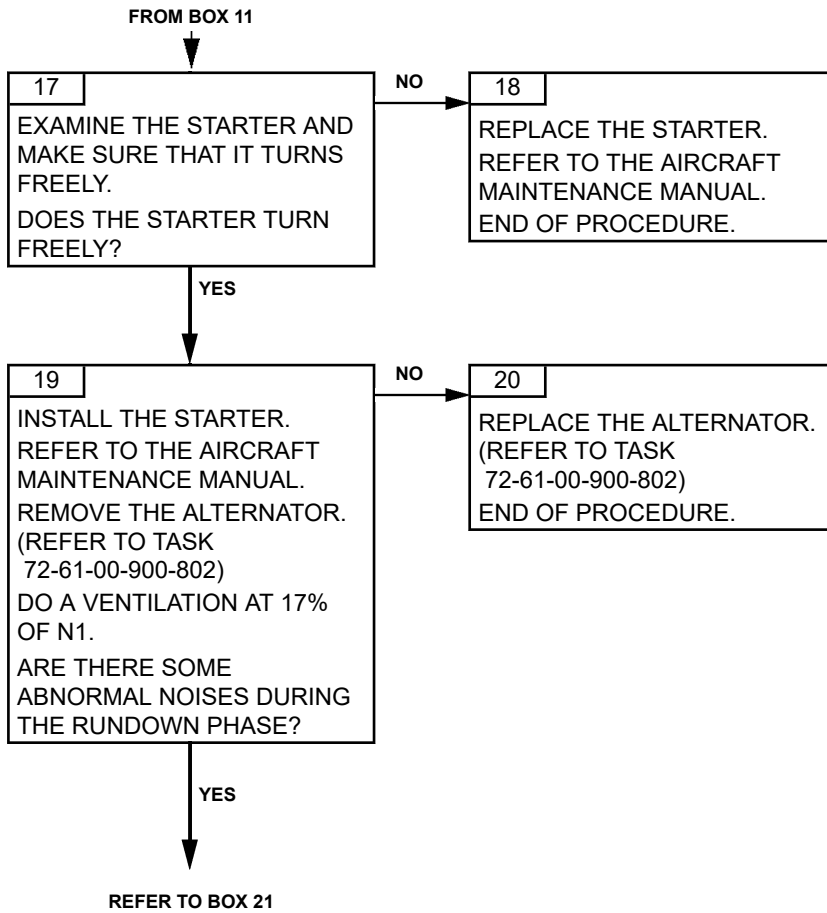

ARRIEL 2 C1

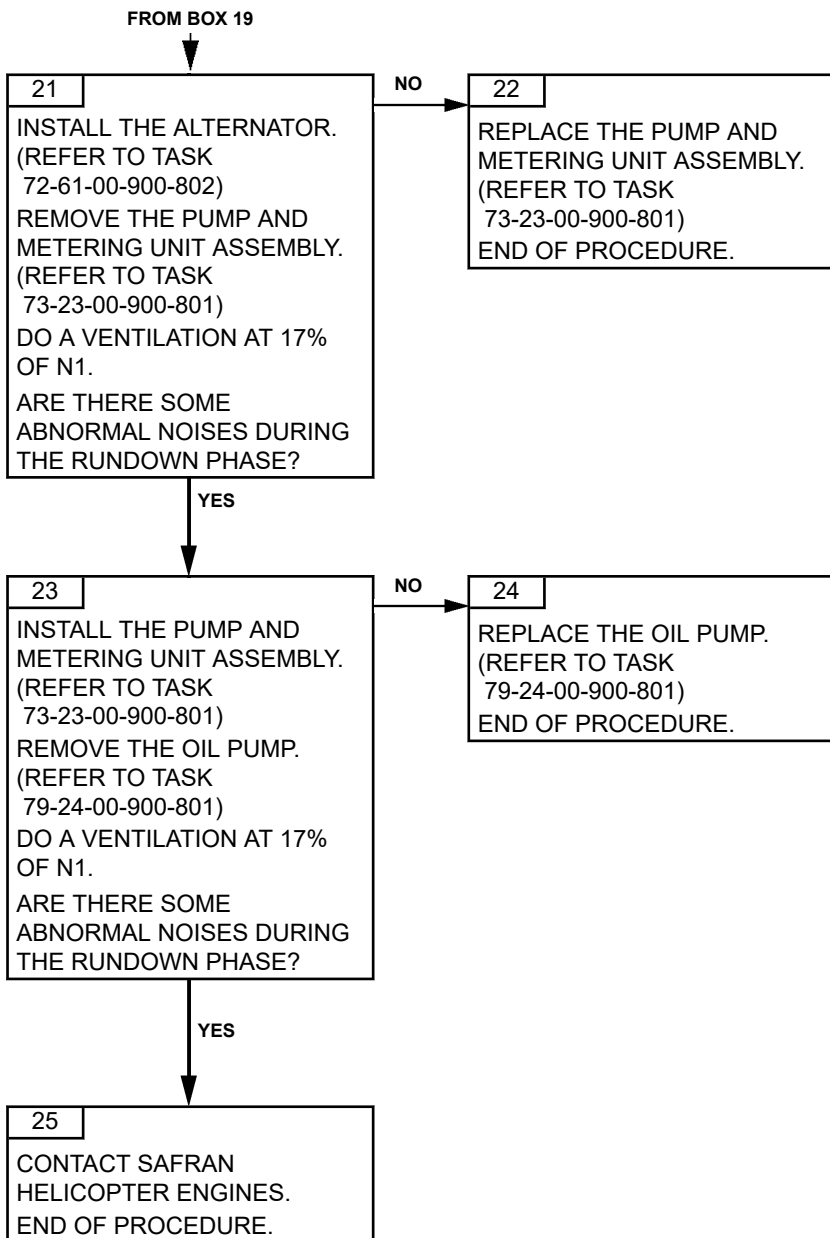

PAGE LEFT BLANK INTENTIONALLY

TASK 71-00-06-815-802-A01

**RUNDOWN TIME OUT OF LIMIT
TROUBLESHOOTING****1. GENERAL****A. PHASE AND FAILURE DETECTION**

Phase	OTHER AVIONIC INDICATION	
	Alarms VEMD	Warning indicator lights
SHUTDOWN	N/A	N/A

Phase	MH65E INDICATION		
	MFD EICAS page	CDU TDL page	ECMS page
SHUTDOWN	N/A	N/A	N/A

B. REMINDER OF THE NORMAL OPERATING CONDITION

In normal condition, the rundown time of the gas generator must be higher than the criteria given in Maintenance Manual task. (Refer to Task 71-02-09-760-801).

C. POSSIBLE CAUSES

- Module 01 - Accessory gearbox and transmission shaft
- Module 02 - Compressor
- Module 03 - Gas generator
- Starter generator
- Oil pump
- HMU
- Alternator

2. PROCEDURE

NOTE: *It is necessary to check the permeability of the injection wheel so as to rule on the effectivity of the MTI X292M1308. This MTI makes it possible to clean or replace the injection manifold and to replace the HP turbine. It makes it possible to free from the full replacement of the module 03.*

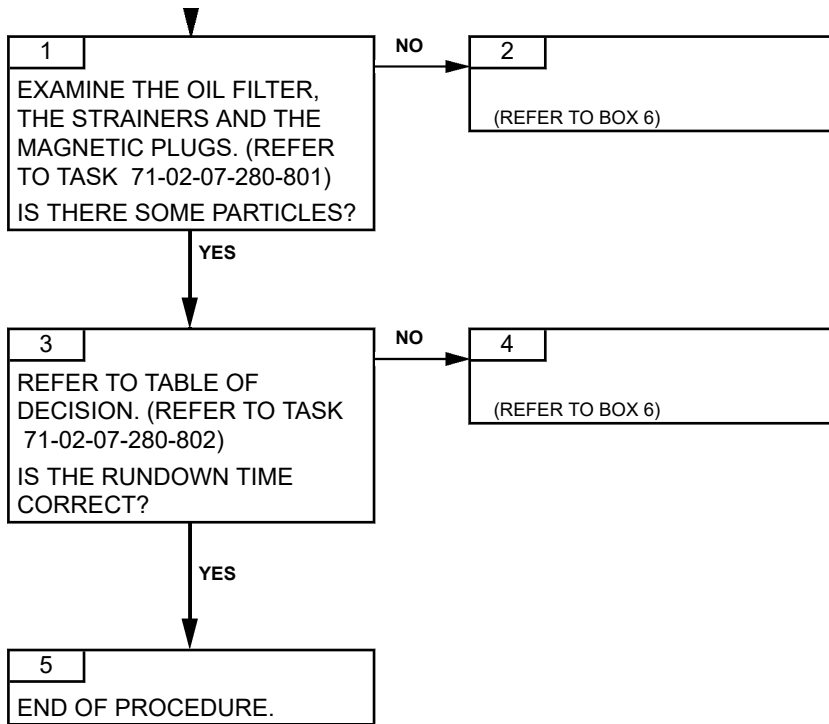

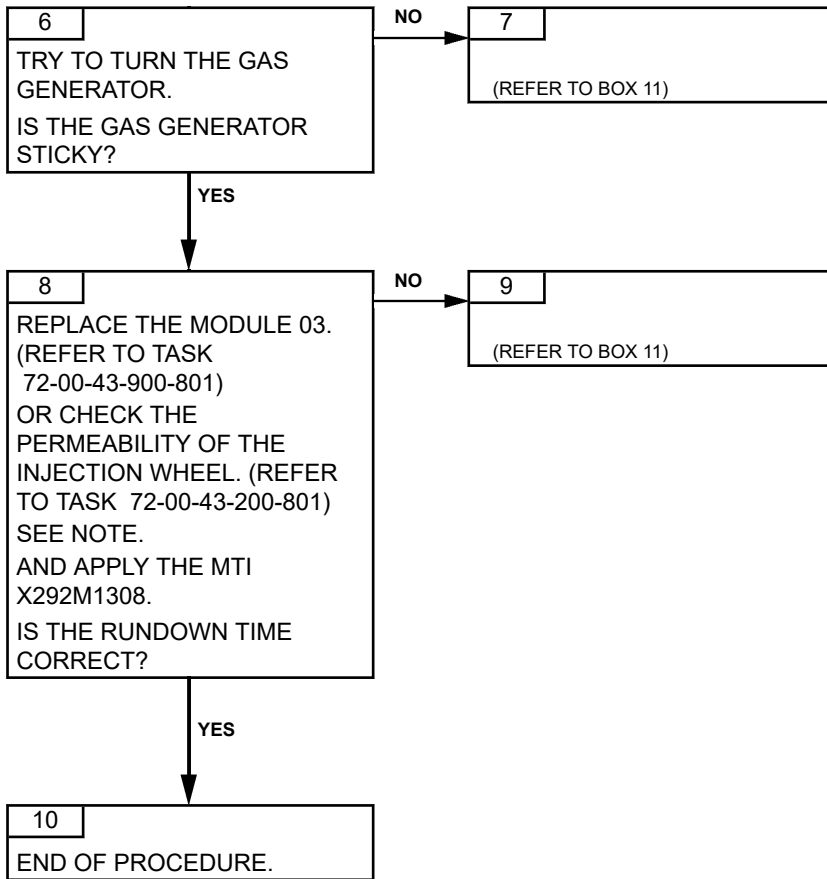

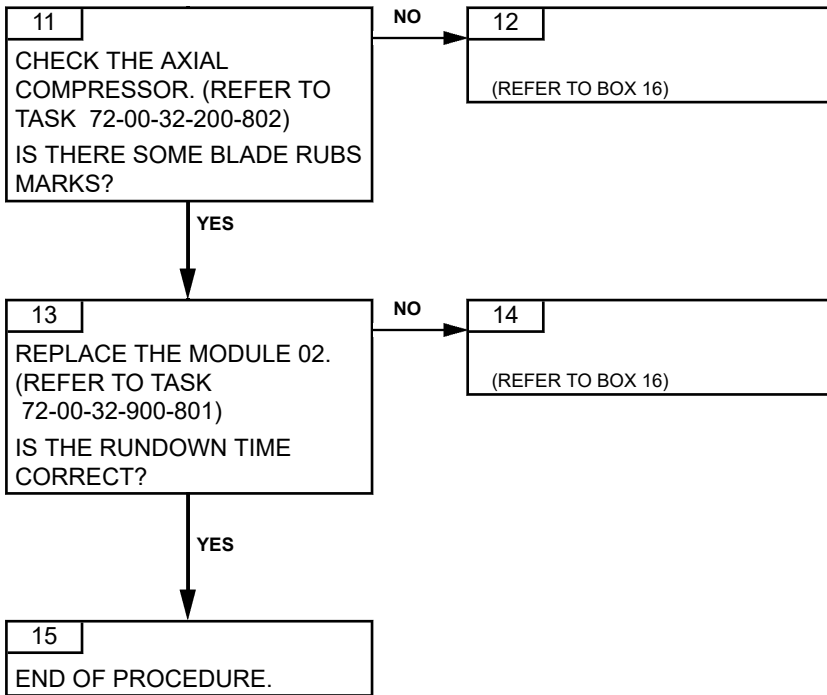

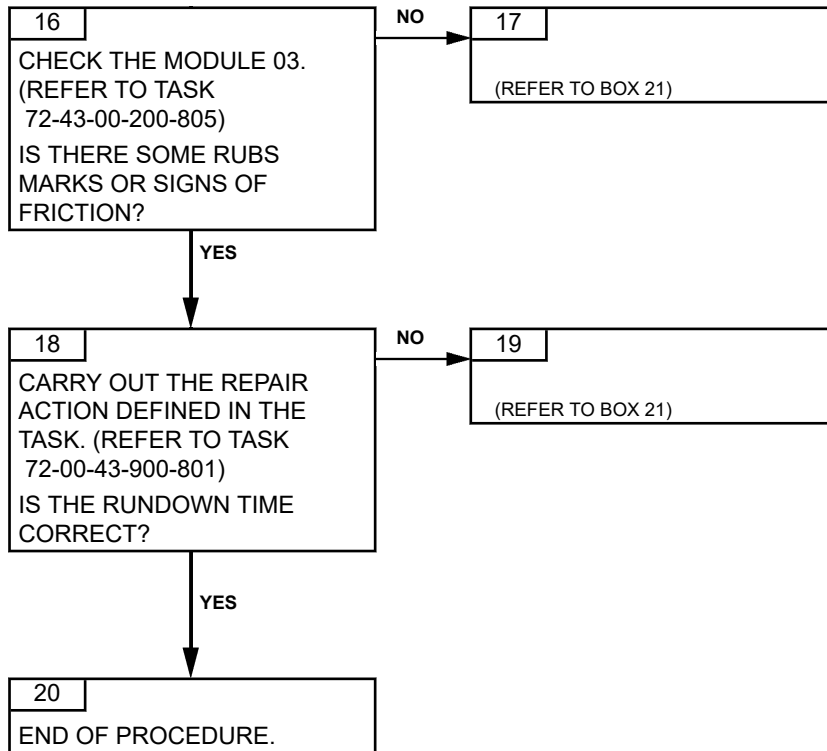

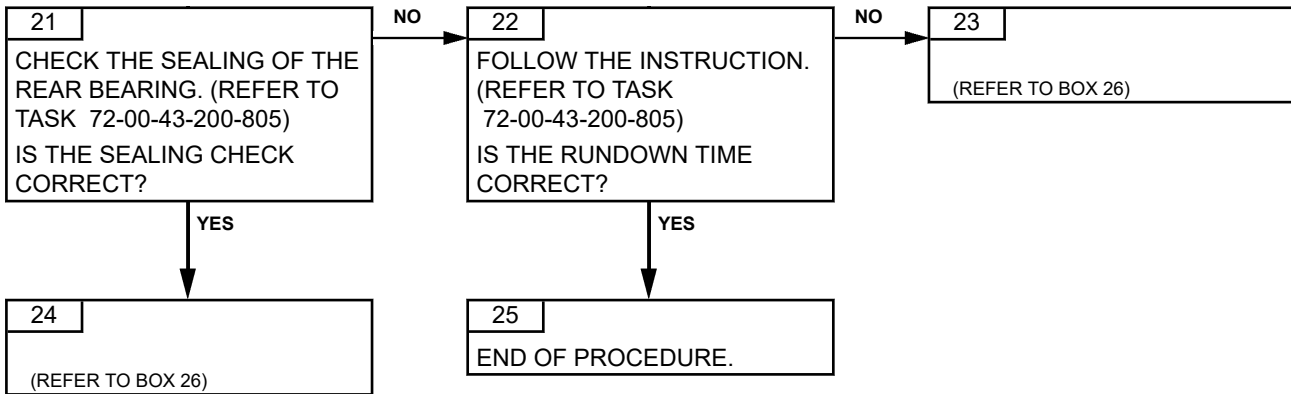

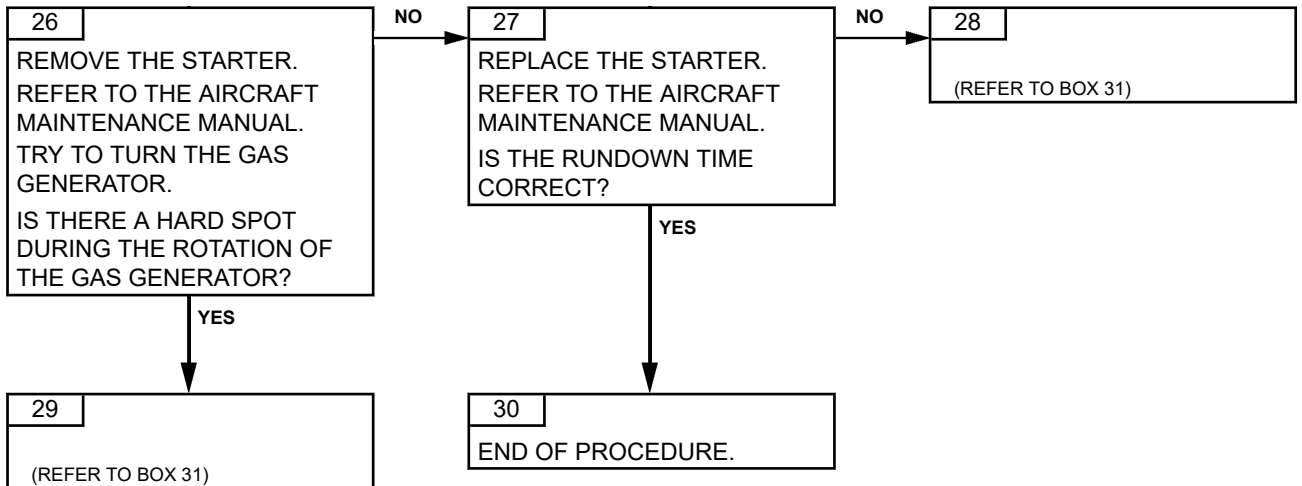

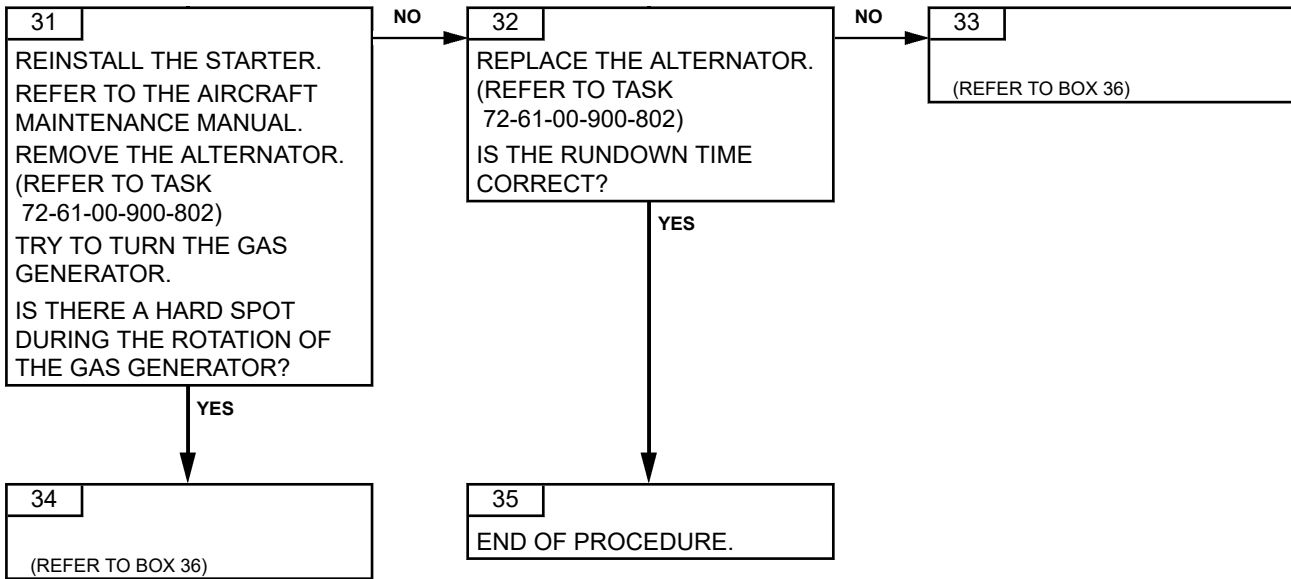

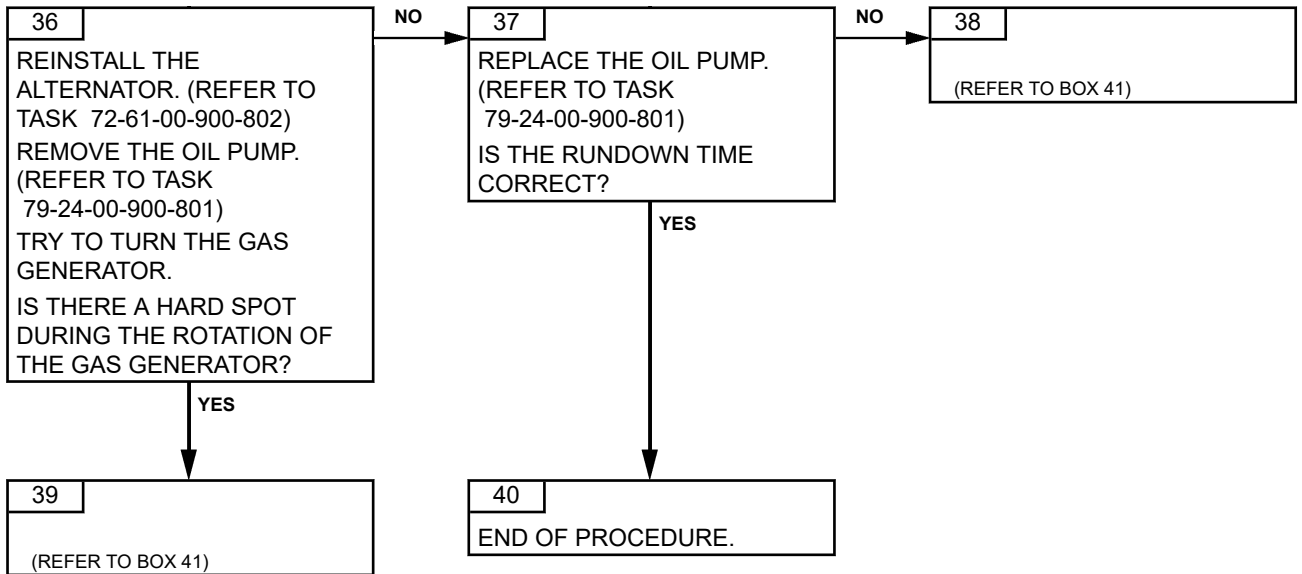

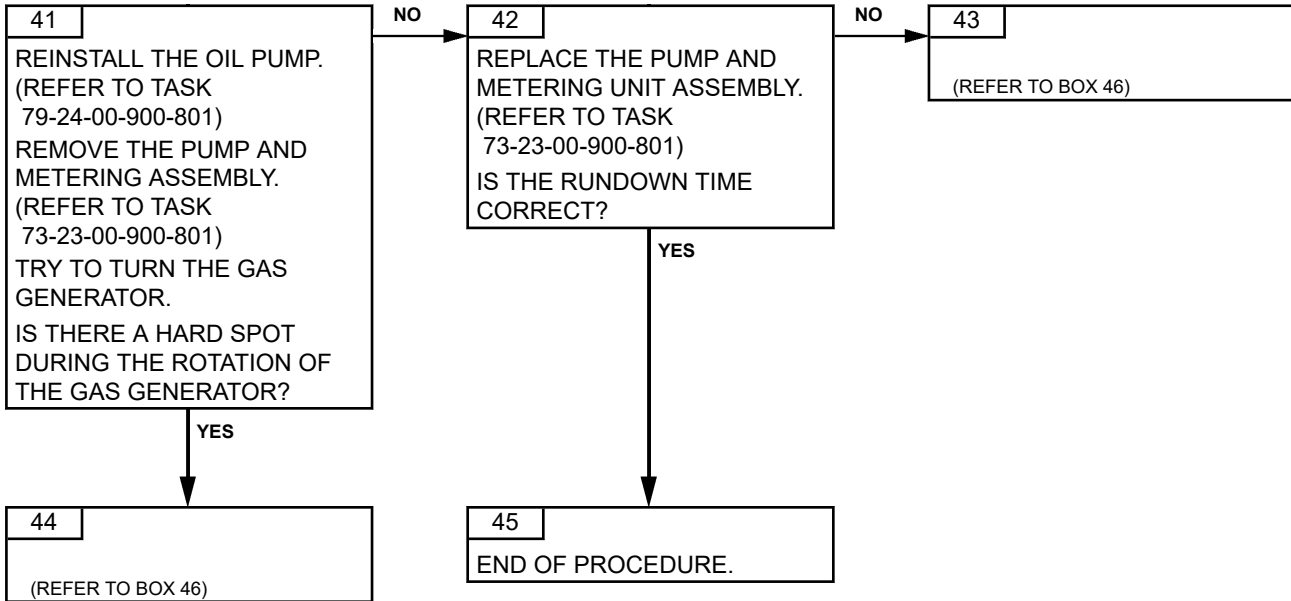

ARRIEL 2 C1

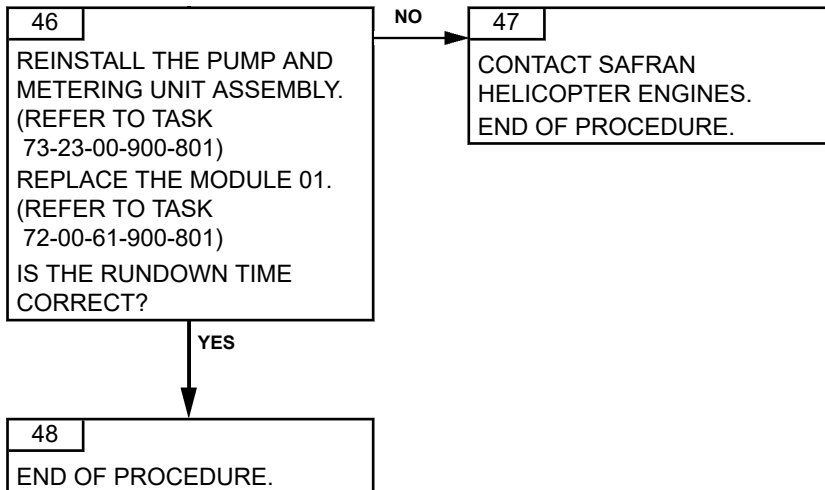

PAGE LEFT BLANK INTENTIONALLY

TASK 71-00-06-815-804-A01

FUEL P OFF - NO LOW FUEL PRESSURE SIGNAL TROUBLESHOOTING

1. GENERAL

A. PHASE AND FAILURE DETECTION

<i>Phase</i>	<i>Indication</i>	
	<i>Alarms VEMD</i>	<i>Warning lights</i>
ENGINE SHUTDOWN		Fuel tank

B. REMINDER OF THE NORMAL OPERATING CONDITION

At engine shutdown, the low fuel pressure signal must be on.

C. POSSIBLE CAUSES

- Low-fuel pressure switch
- Control and monitoring harness
- Aircraft

2. PROCEDURE

Effectivity: C1

Failures observed during engine operation

TURBOMECA ARRIEL 2 C1

MAINTENANCE MANUAL

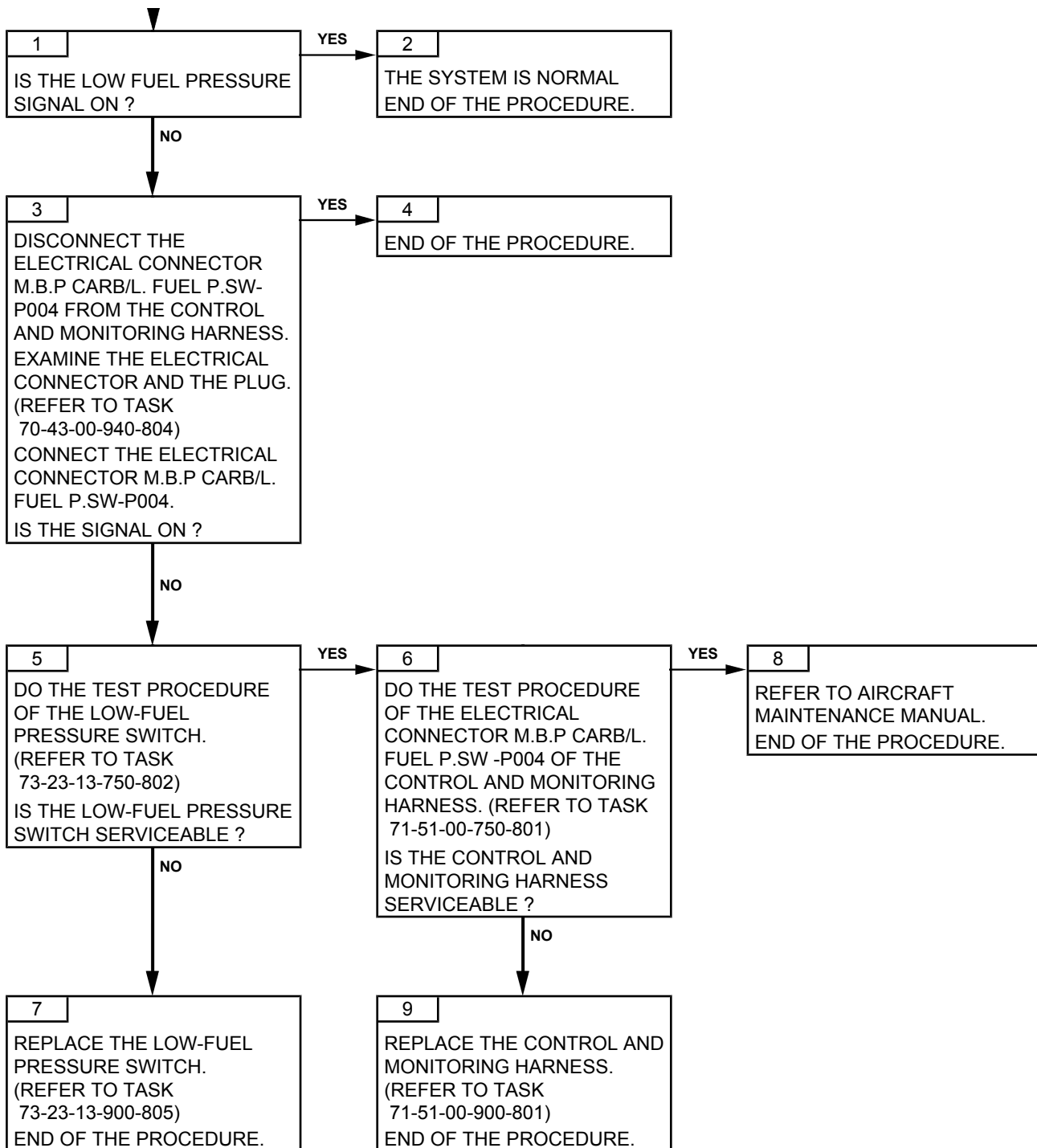

Effectivity: C1

Failures observed during engine operation

TASK 71-00-06-815-805-A01

ENG P OFF - NO LOW OIL PRESSURE SIGNAL TROUBLESHOOTING

1. GENERAL

A. PHASE AND FAILURE DETECTION

<i>Phase</i>	<i>Indication</i>	
	<i>Alarms VEMD</i>	<i>Warning indicator lights</i>
ENGINE SHUTDOWN		Red ENG 1 or ENG 2 off

B. REMINDER OF THE NORMAL OPERATING CONDITION

At engine shutdown, the ENG 1 or ENG 2 Lights must be on.

C. POSSIBLE CAUSES

- Low-oil pressure switch
- Control and monitoring harness
- Aircraft

2. PROCEDURE

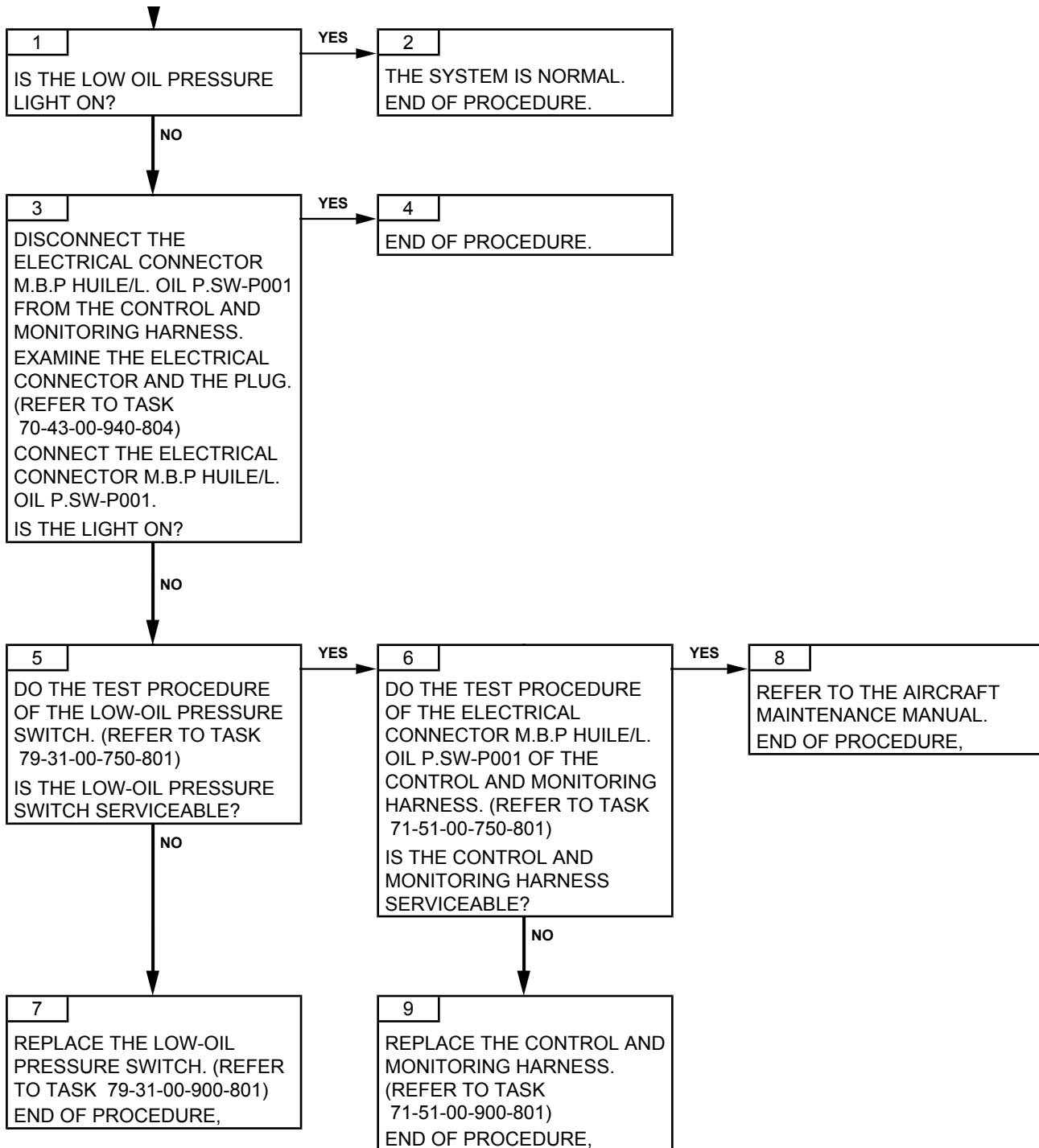

TASK 71-00-06-815-806-A01

**POWER TURBINE BLOCKED
TROUBLESHOOTING**

1. GENERAL

A. GENERAL DESCRIPTION

At engine shutdown, the power turbine must turn freely.

B. POSSIBLE CAUSES

- Exhaust pipe assembly
- Labyrinth ring

2. PROCEDURE

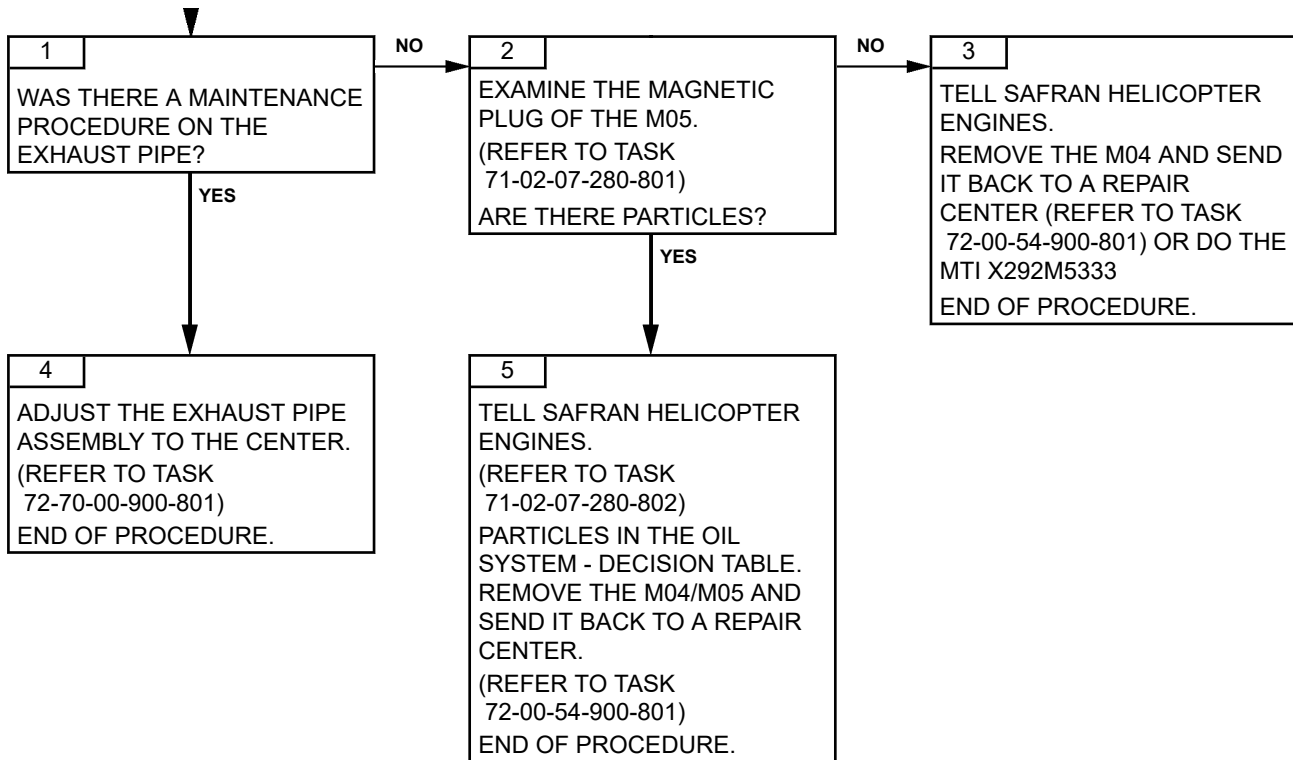

TASK 71-00-06-816-801-A01

**SMOKE FROM EXHAUST PIPE
TROUBLESHOOTING****1. GENERAL****A. REMINDER OF THE NORMAL OPERATING CONDITION**

- In normal operating condition, no white smoke at the exhaust pipe outlet and no important oil consumption.

B. POSSIBLE CAUSES

- Clogging of the rear bearing
- Breather sealing ring
- Module 03
- P3 tube of module 05
- Module 04
- Module 03 breather pipe
- Vent line
- Start electro-valve

2. PROCEDURE

NOTE: *If the oil tank is overfilled, excess oil will be consumed via the vent line until optimum oil tank level is reached. This may cause some oil smoke at the exhaust.*

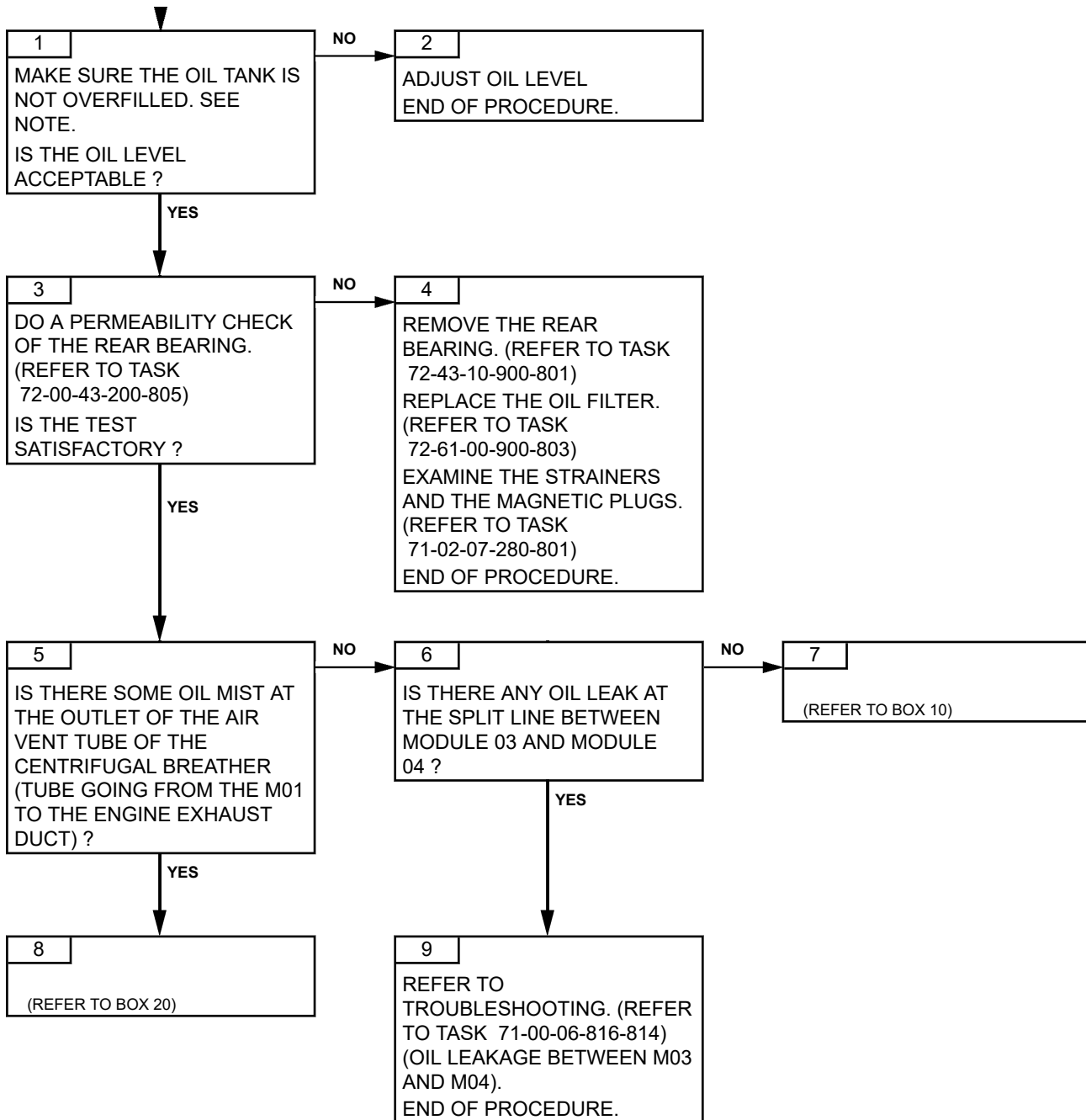

ARRIEL 2 C1

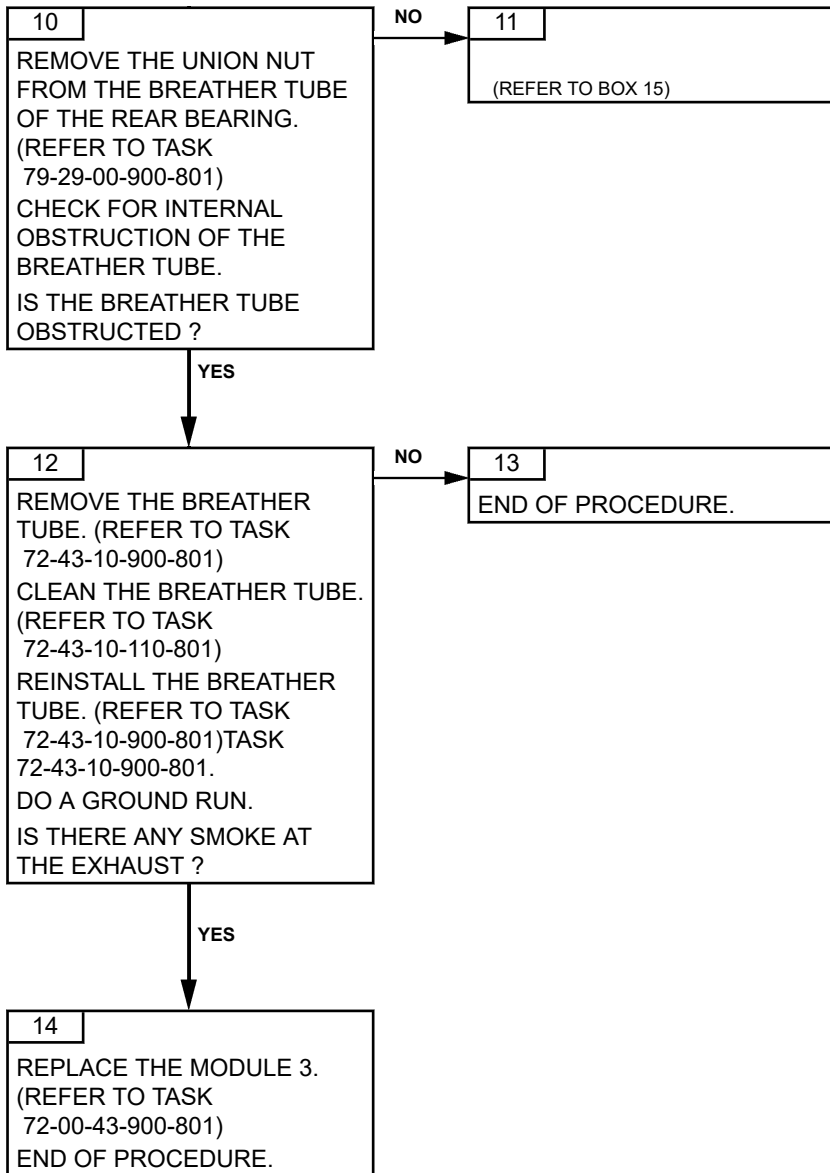

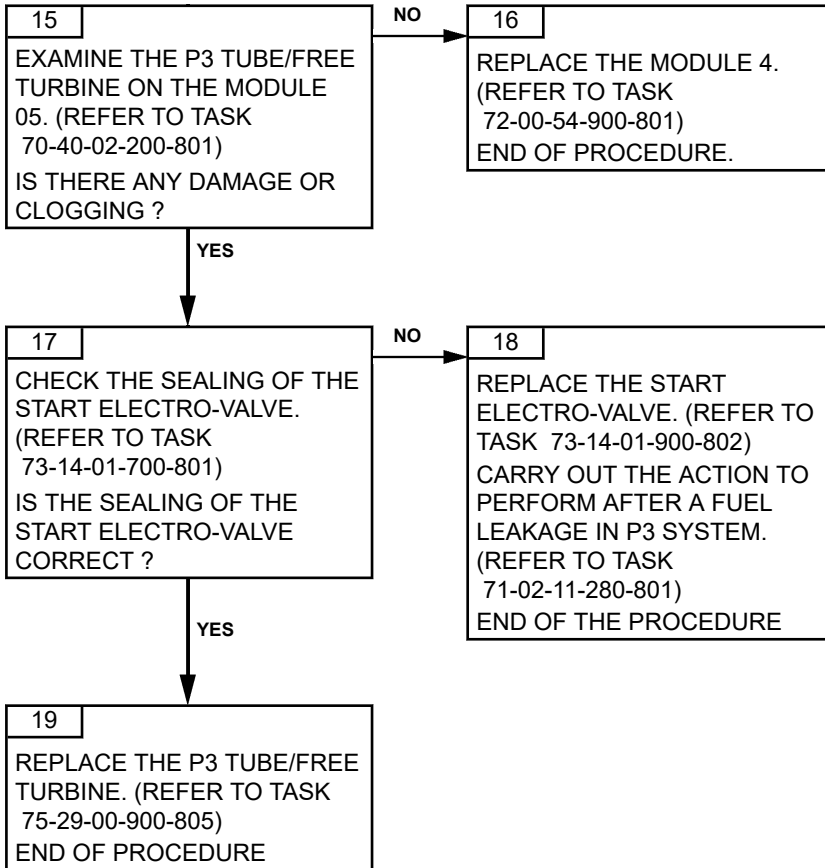

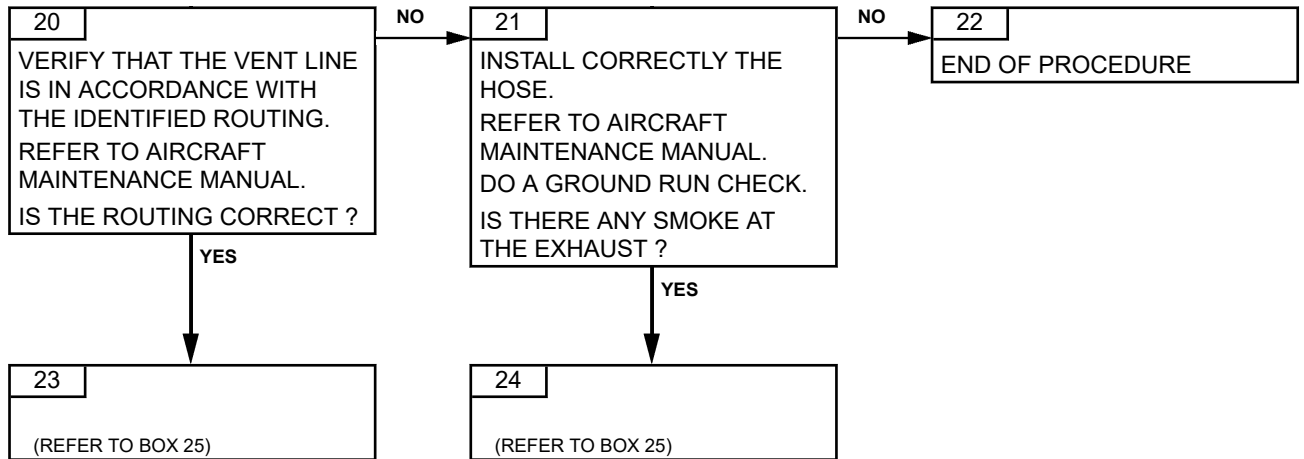

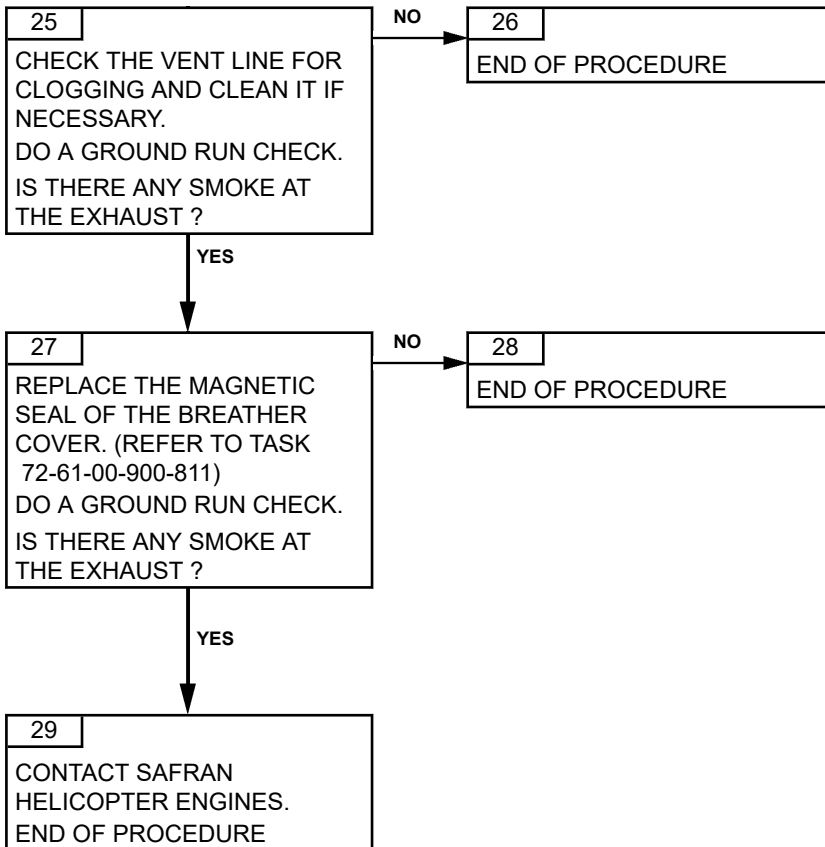

TASK 71-00-06-816-803-A01

**PARTICLES IN THE OIL FILTERING ELEMENT
TROUBLESHOOTING**

1. GENERAL

CAUTION: ACCEPT THE PRESENCE OF SOME CUTTING CHIPS ONLY DURING THE 20 FIRST HOURS OF THE ENGINE OPERATION.

CAUTION: SEND THE PARTICLES TO A SPECIALIZED LABORATORY FOR ANALYSIS. ONLY A SPECIALIZED LABORATORY CAN MAKE AN ACCURATE DIAGNOSIS.

A. FAILURE DETECTION CONDITIONS

- Findings made from the application of the removal procedure of the oil filtering element (Refer to Task 72-61-00-900-803)

B. POSSIBLE CAUSES

- Damage of a rotating assembly
- Damage of a seal, etc
- Clogging of the rear bearing.

2. PROCEDURE

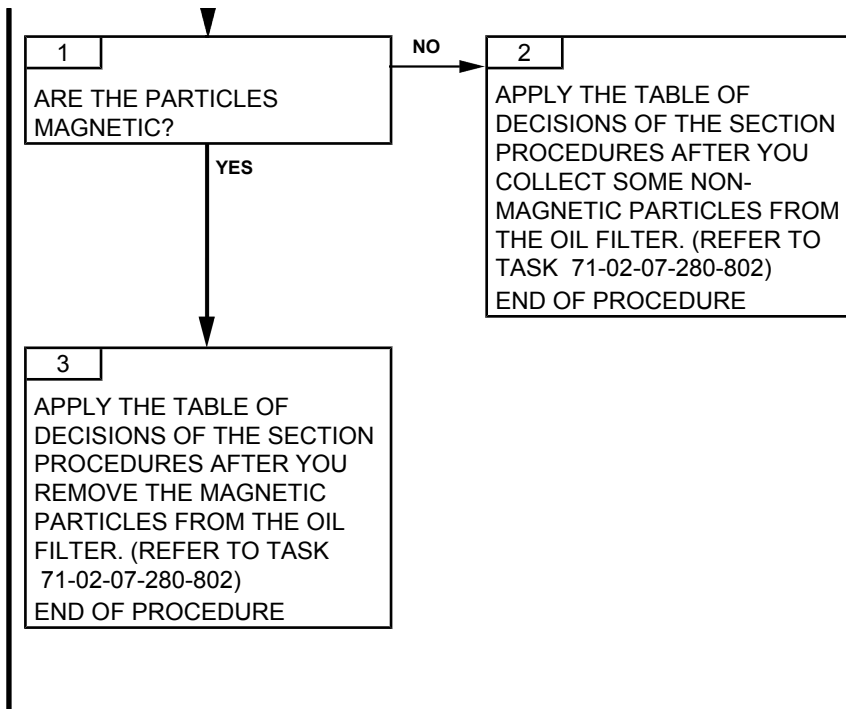

TASK 71-00-06-816-804-B01

**LEAK AT THE AIRCRAFT DRAIN CLUSTER
TROUBLESHOOTING****1. GENERAL****A. REMINDER OF THE NORMAL OPERATING CONDITION OR FAILURE
DETECTION**

This troubleshooting task is relevant in case of abnormal leak noticed at the helicopter drain under the engine deck.

- In the event of an oil leakage, this one must meet the criteria defined on the Task 79-00-00-280-801.
- In the event of a fuel leakage, this one must meet the criteria defined on the Task 73-23-00-700-801.

B. POSSIBLE CAUSES

- Magnetic seal of the transmission shaft
- Sealing ring of the fuel filtering element
- Varilip seal of the pump and metering unit assembly.
- Engine or equipment external leakage

2. PROCEDURE

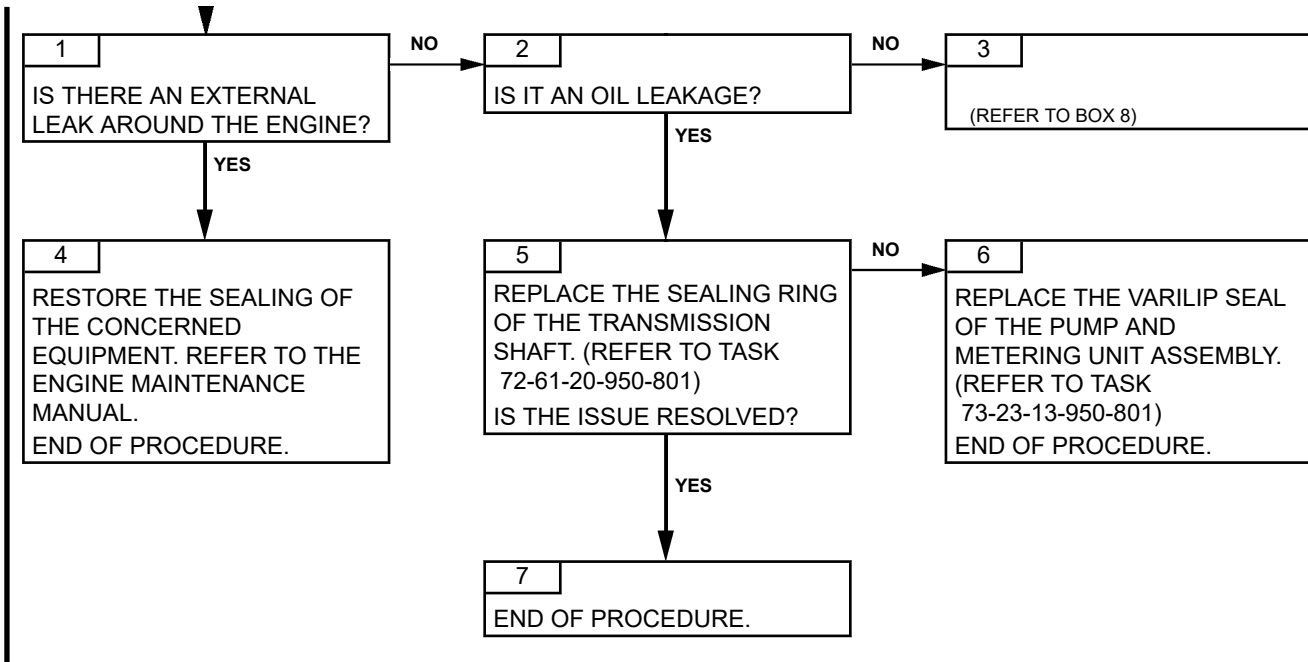

ARRIEL 2 C1

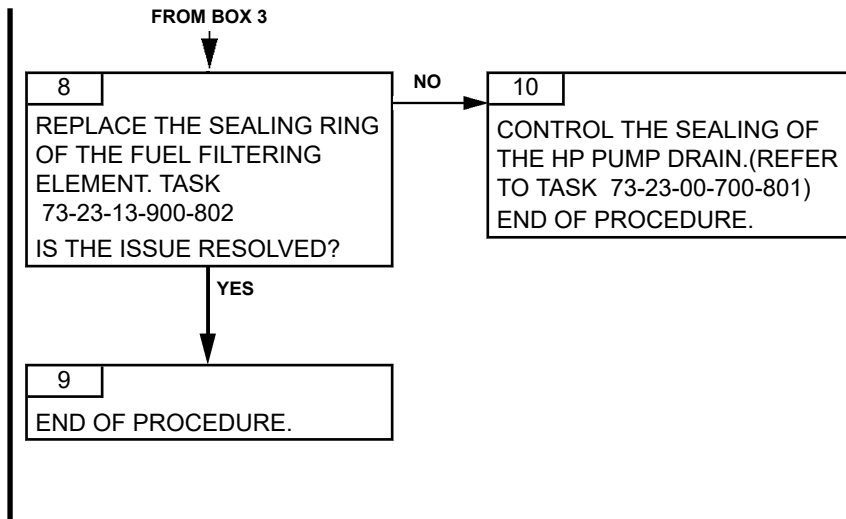

PAGE LEFT BLANK INTENTIONALLY

TASK 71-00-06-816-805-A01

**ABNORMAL FUEL LEAKAGE AT THE TANK RETURN
FUEL TUBE
TROUBLESHOOTING**

1. GENERAL

A. FAILURE DETECTION CONDITIONS

- Findings made after the application of the inspection procedure of the fuel system bleed-system(Refer to Task 72-00-43-200-804)

B. POSSIBLE CAUSES

- Starting air bleed valve
- Fuel valve assembly

2. PROCEDURE

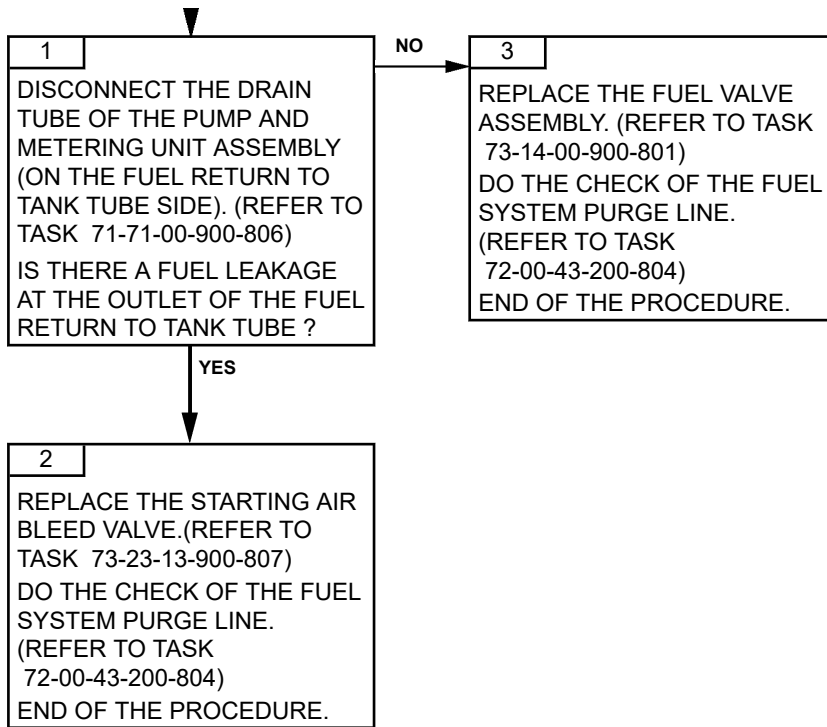

TASK 71-00-06-816-806-A01

**FUEL FILTER CLOGGING INDICATOR POPPED OUT
TROUBLESHOOTING****1. GENERAL****A. PHASE AND FAILURE DETECTION**

- The red fuel filter mechanical blockage indicator is popped out.

B. GENERAL DESCRIPTION

The engine is equipped of:

- one fuel filter pre-blockage pressure switch connected to the aircraft.
- one red fuel filter mechanical blockage indicator.

C. POSSIBLE CAUSES

- Pre-blockage pressure switch of the fuel filtering element
- Control and indicating harness
- Blockage visual indicator of the fuel filter
- Fuel contamination

2. PROCEDURE

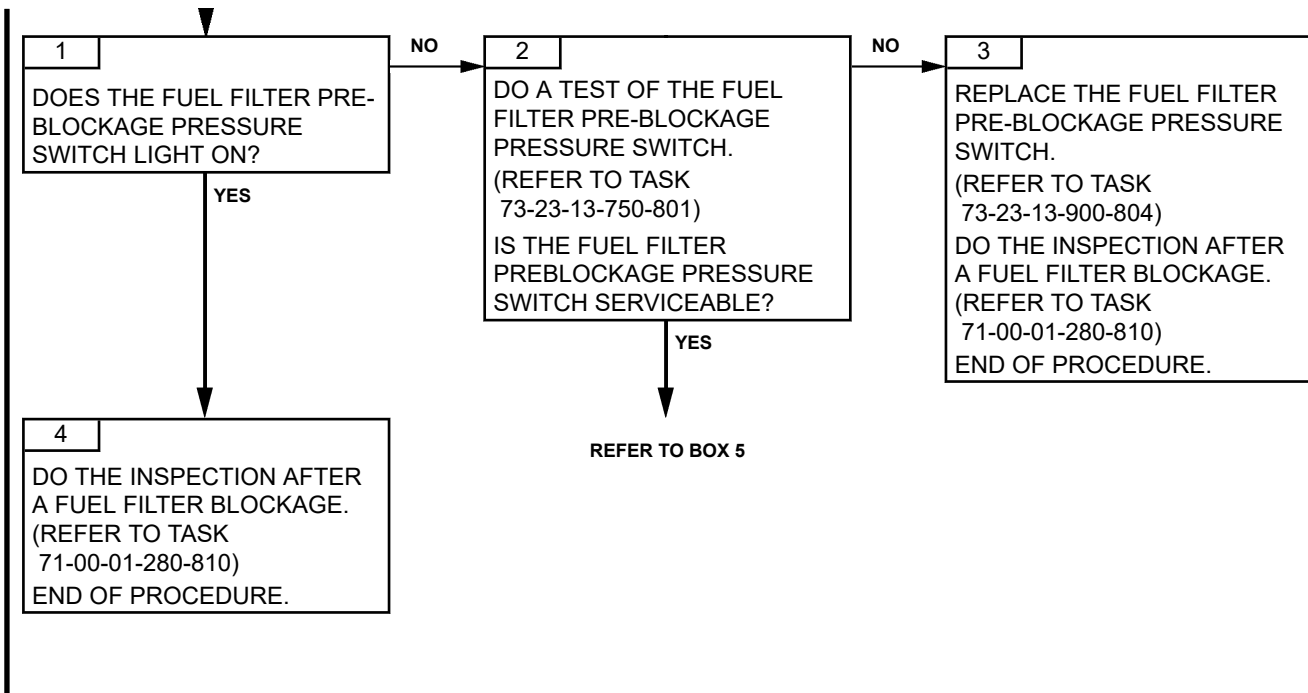

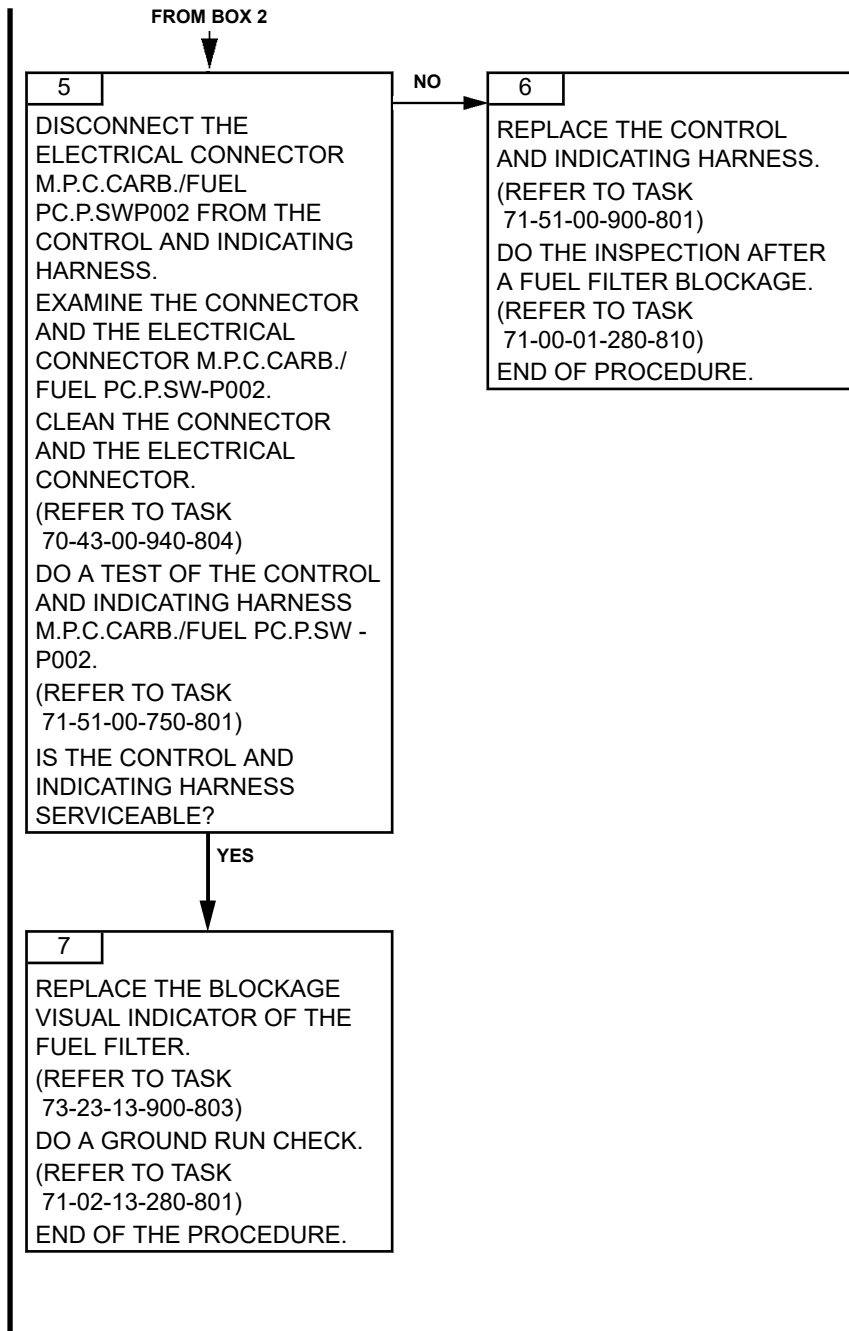

PAGE LEFT BLANK INTENTIONALLY

TASK 71-00-06-816-807-A01

**FUEL DILUTION RATE IN OIL NOT COMPLIANT
TROUBLESHOOTING****1. GENERAL****A. REMINDER OF THE NORMAL OPERATING CONDITION**

This troubleshooting task is applicable when the result of the control of the fuel dilution in oil defined in Task 70-02-00-940-801 is not compliant.

B. POSSIBLE CAUSES

- Oil filter
- Start electrovalve

NOTE: *A failure at the start electrovalve can come along with a smell of fuel in the cockpit and/or of smoke at the exhaust pipe.*

2. PROCEDURE

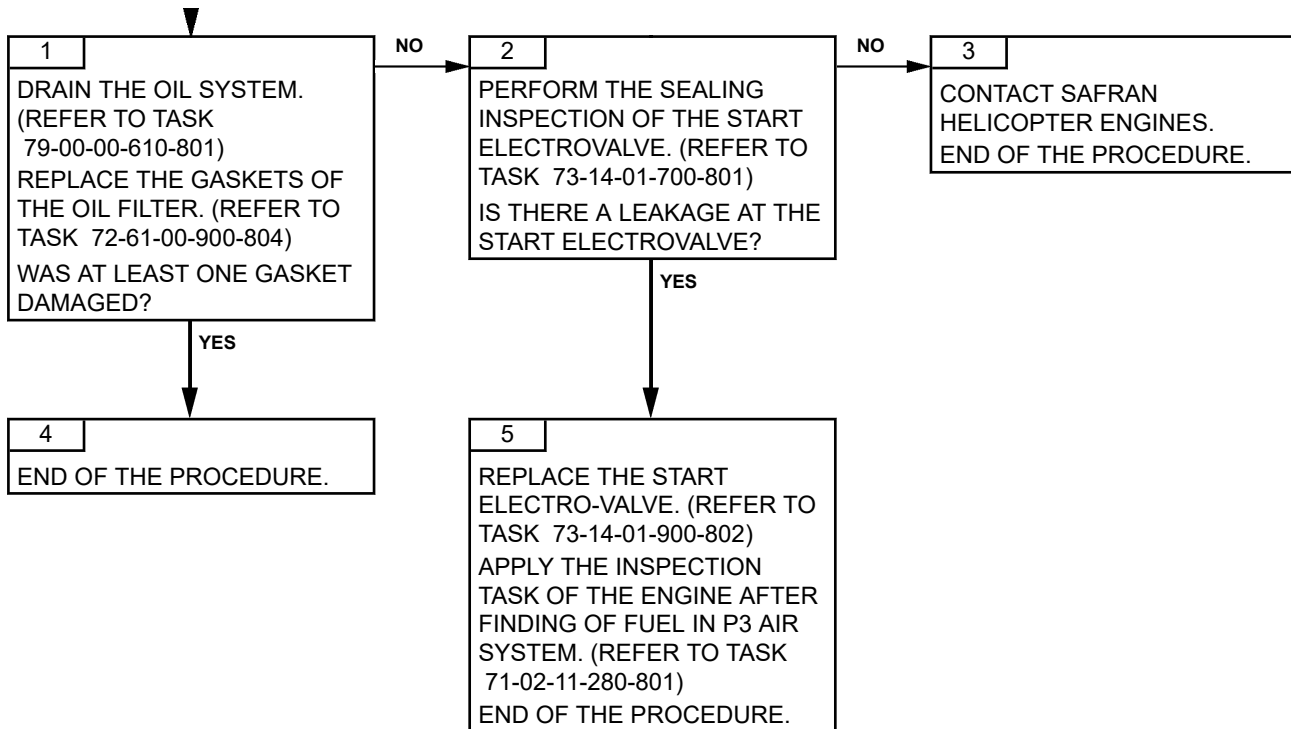

TASK 71-00-06-816-808-A01

**INCORRECT OPERATION OF ONE OF THE IGNITION
DEVICE LINES
TROUBLESHOOTING**

1. GENERAL

A. FAILURE DETECTION CONDITIONS

- Finding after the application of the check and inspection procedure of the ignition system
(Refer to Task 72-43-00-200-806)
- The second ignition SYSTEM is serviceable after the application of task
(Refer to Task 72-43-00-200-806)

B. POSSIBLE CAUSES

- High energy ignition unit
- Ignition cable
- Igniter plug

2. PROCEDURE

TURBOMECA ARRIEL 2 C1

MAINTENANCE MANUAL

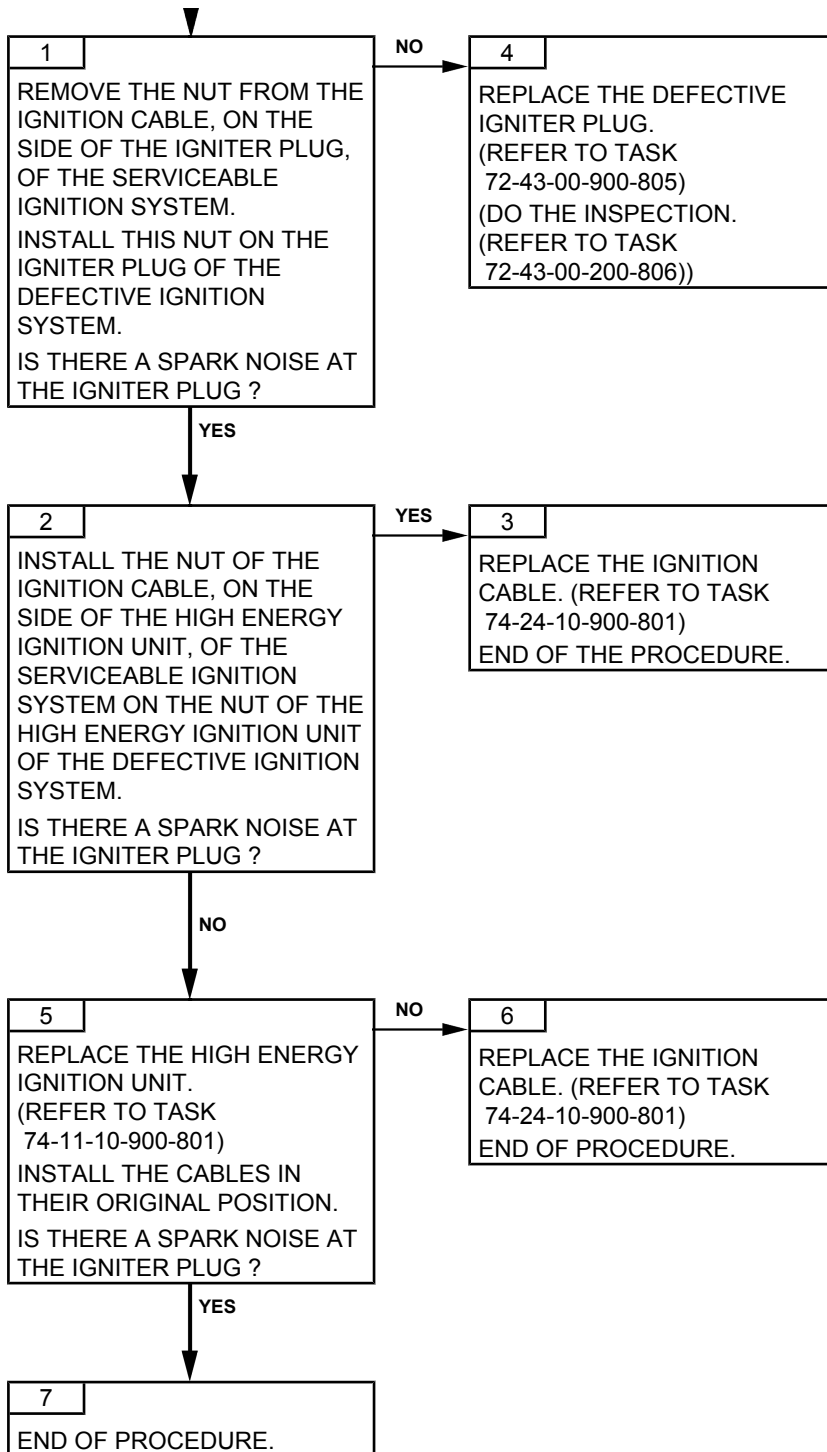

Effectivity: C1

Failures observed during maintenance

TASK 71-00-06-816-810-A01

**PARTICLES ON A MAGNETIC PLUG
TROUBLESHOOTING**

1. GENERAL

CAUTION: ACCEPT THE PRESENCE OF SOME CUTTING CHIPS ONLY DURING THE FIRST 20 HOURS OF THE ENGINE OPERATION.

CAUTION: SEND THE PARTICLES TO A SPECIALIZED LABORATORY FOR THE ANALYSIS. ONLY A SPECIALIZED LABORATORY CAN MAKE AN ACCURATE DIAGNOSIS.

A. FAILURE DETECTION CONDITIONS

- Findings made from the application of the particles sampling procedure in the oil system (Refer to Task 71-02-07-280-801)

B. POSSIBLE CAUSES

- Damage of a rotating assembly
- Incorrect positioning of a mechanical assembly after a maintenance task.

2. PROCEDURE

Effectivity: C1

Failures observed during maintenance

1

APPLY THE TABLE OF
DECISIONS OF THE SECTION
PROCEDURES AFTER YOU
GET A SAMPLE OF THE
PARTICLES ON THE
MAGNETIC PLUGS(REFER TO
TASK 71-02-07-280-802)
END OF PROCEDURE

ARRIEL 2 C1

TASK 71-00-06-816-811-A01

NON CONFORM OIL CONSUMPTION TROUBLESHOOTING

1. GENERAL

A. REMINDER OF THE NORMAL OPERATING CONDITION

- During operation, the oil consumption must be less than the limit defined.
(Refer to Task 79-00-00-200-801).

B. POSSIBLE CAUSES

- Rear bearing (clogging of duct)
- Module 04 (bad sealing of labyrinth seal)
- Magnetic seal of the drive shaft
- Aircraft (vent pipe, hose)
- Magnetic seal of the breather
- P3 tube of the module 05 (bad sealing of M04 labyrinth seal)
- Preformed packing of the breather cover
- Oil tubes and unions.

2. PROCEDURE

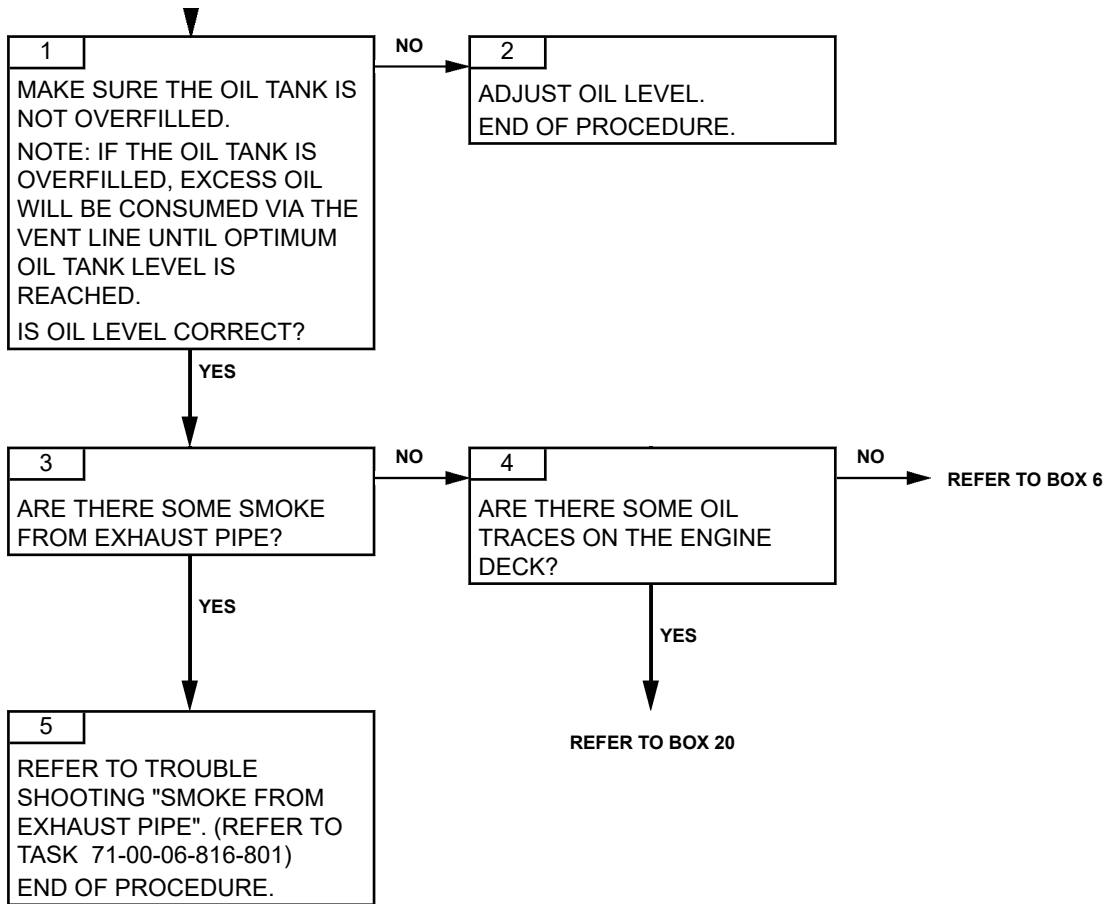

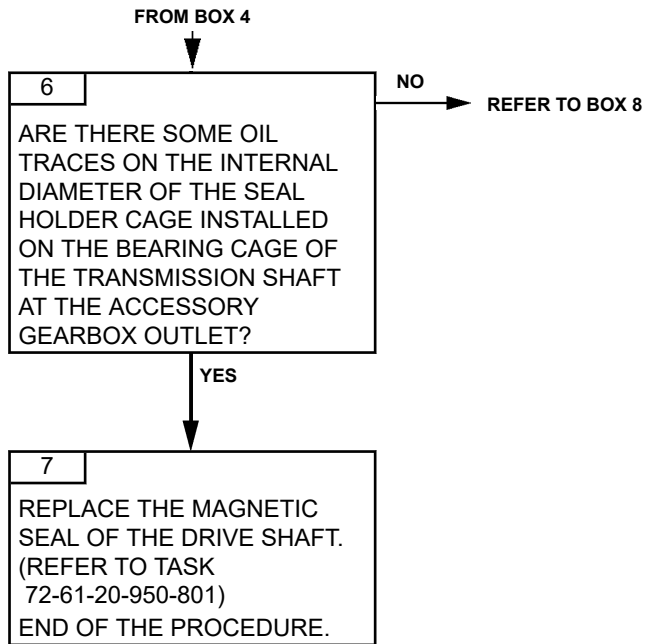

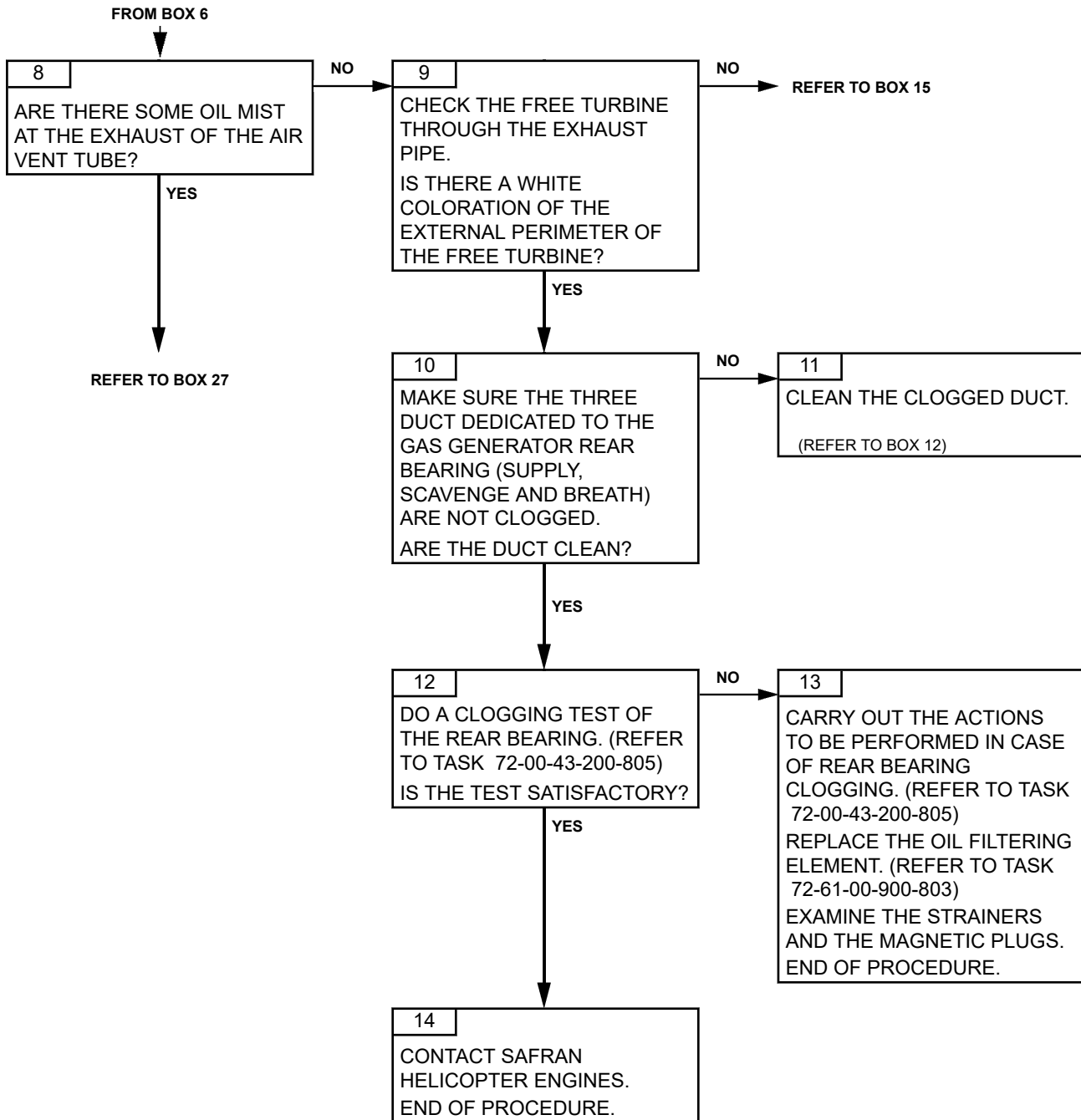

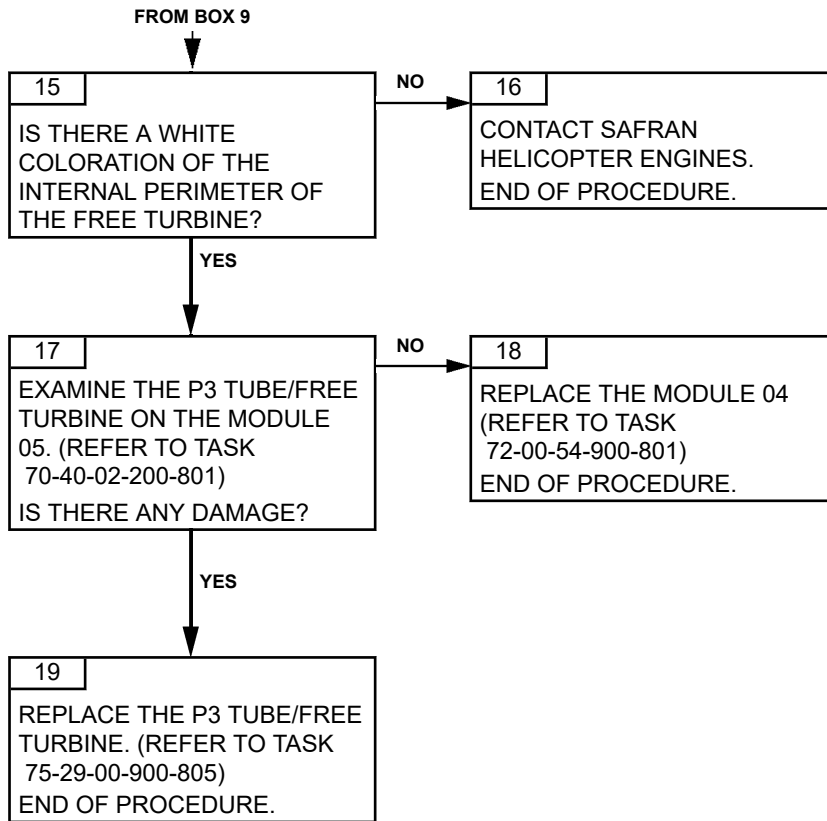

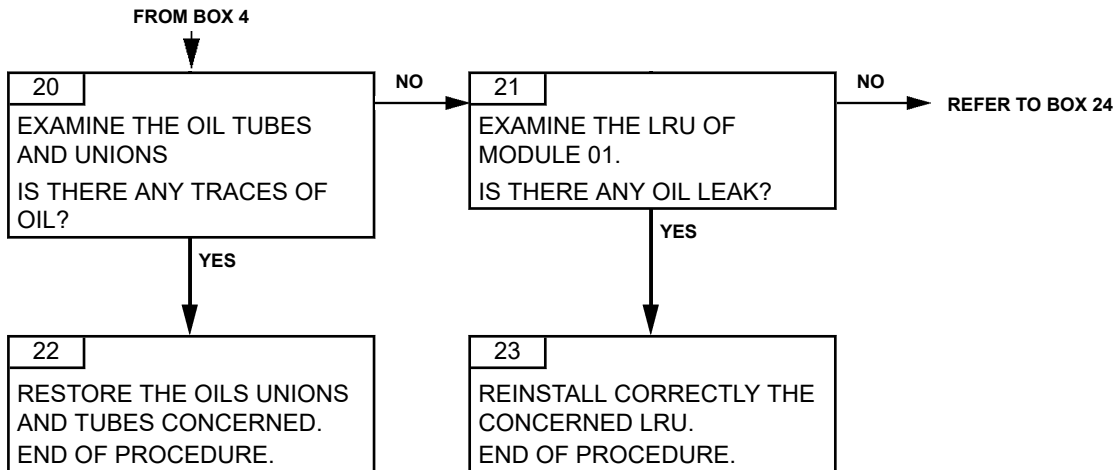

ARRIEL 2 C1

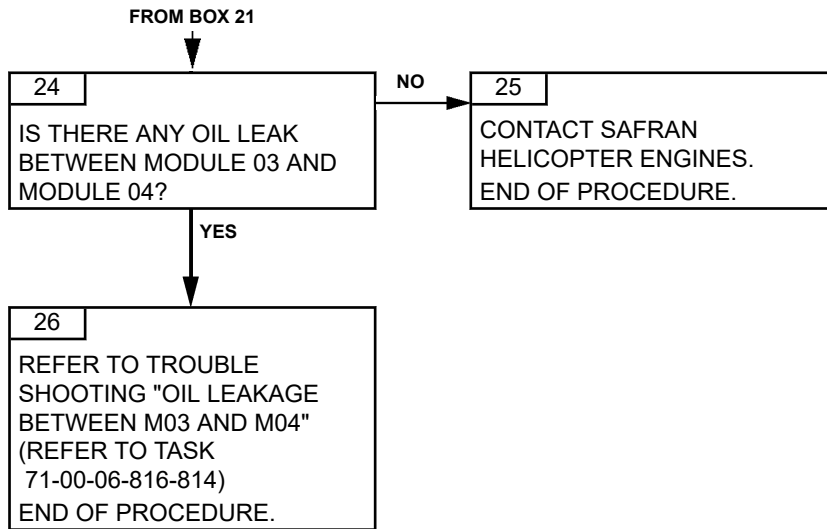

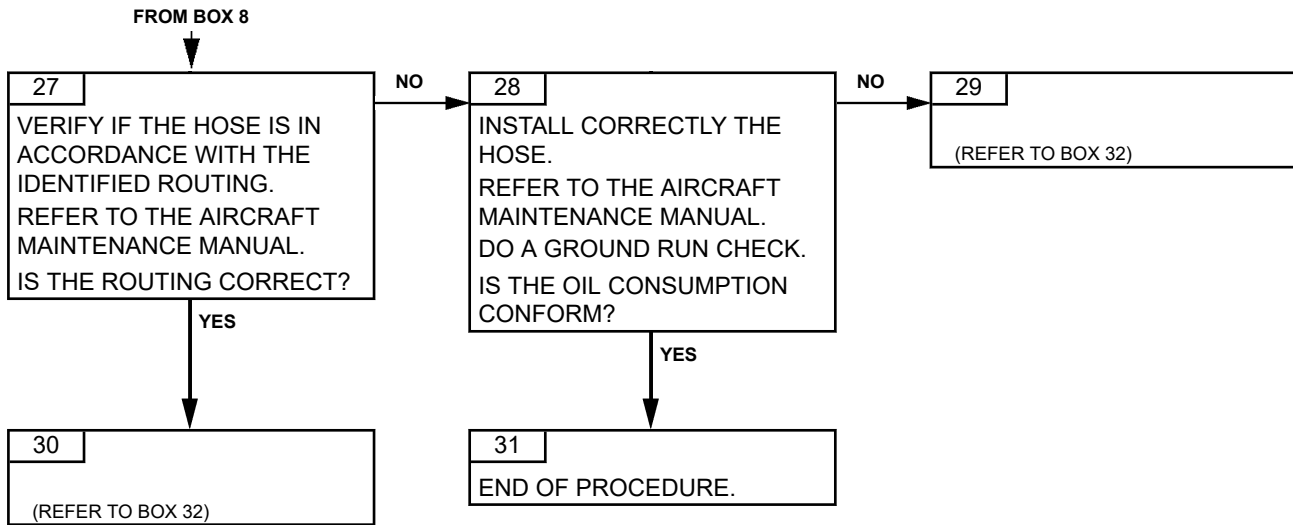

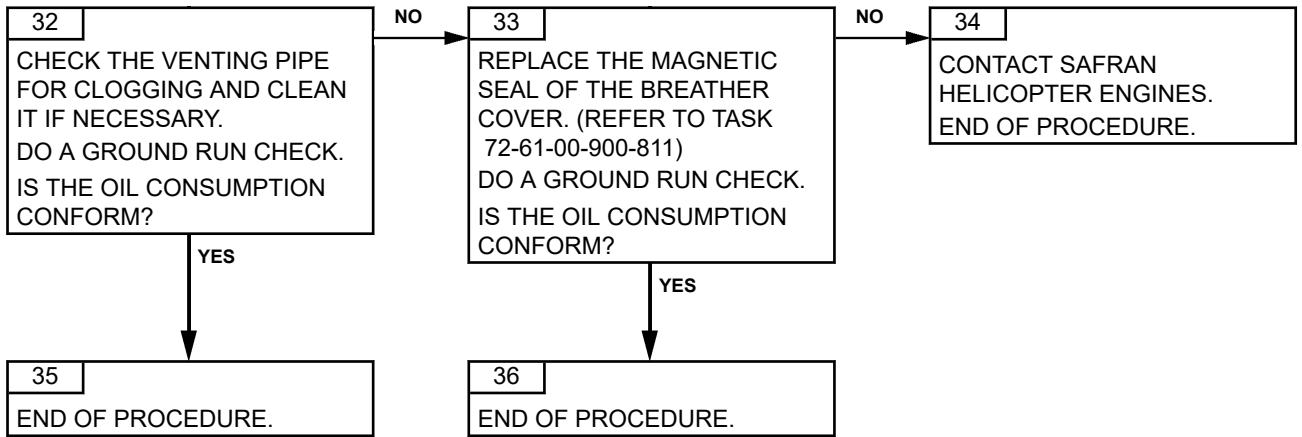

PAGE LEFT BLANK INTENTIONALLY

TASK 71-00-06-816-812-A01

**CHECK OF ABNORMAL OIL PRESSURE
TROUBLESHOOTING**

1. GENERAL

A. PHASE AND FAILURE DETECTION

- After a check of the oil pressure (Refer to Task 79-00-00-200-801).

B. POSSIBLE CAUSES

- Clogging of the rear bearing
- Leaks
- Oil system contamination
- Oil pump
- Reduction gearbox module (M05).

2. PROCEDURE

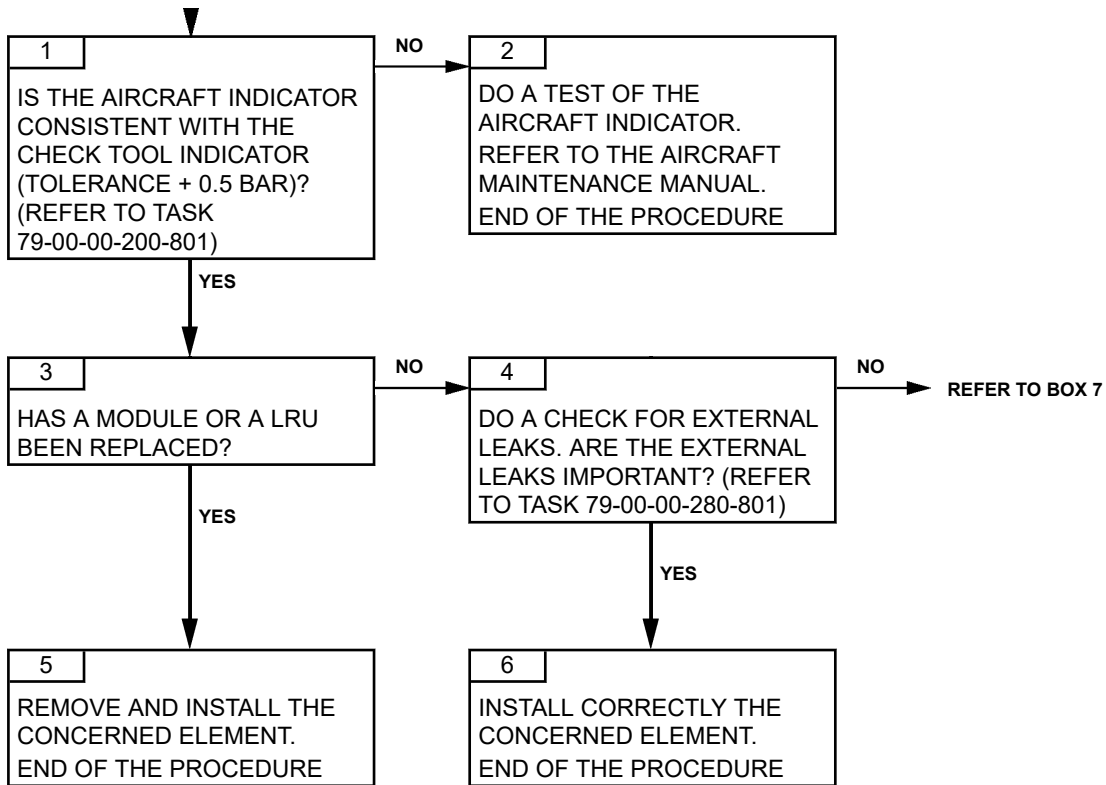

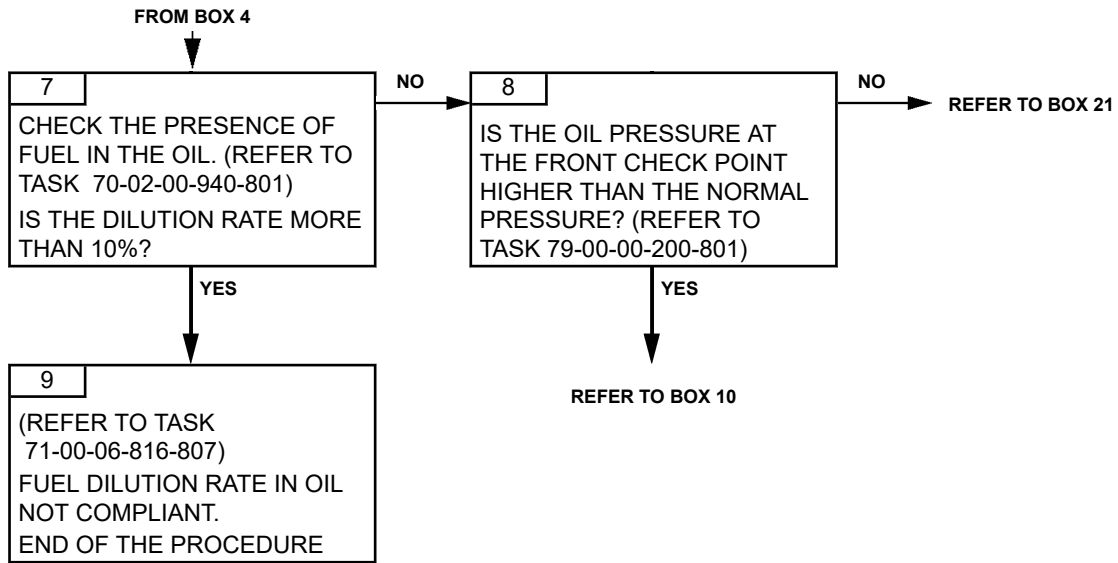

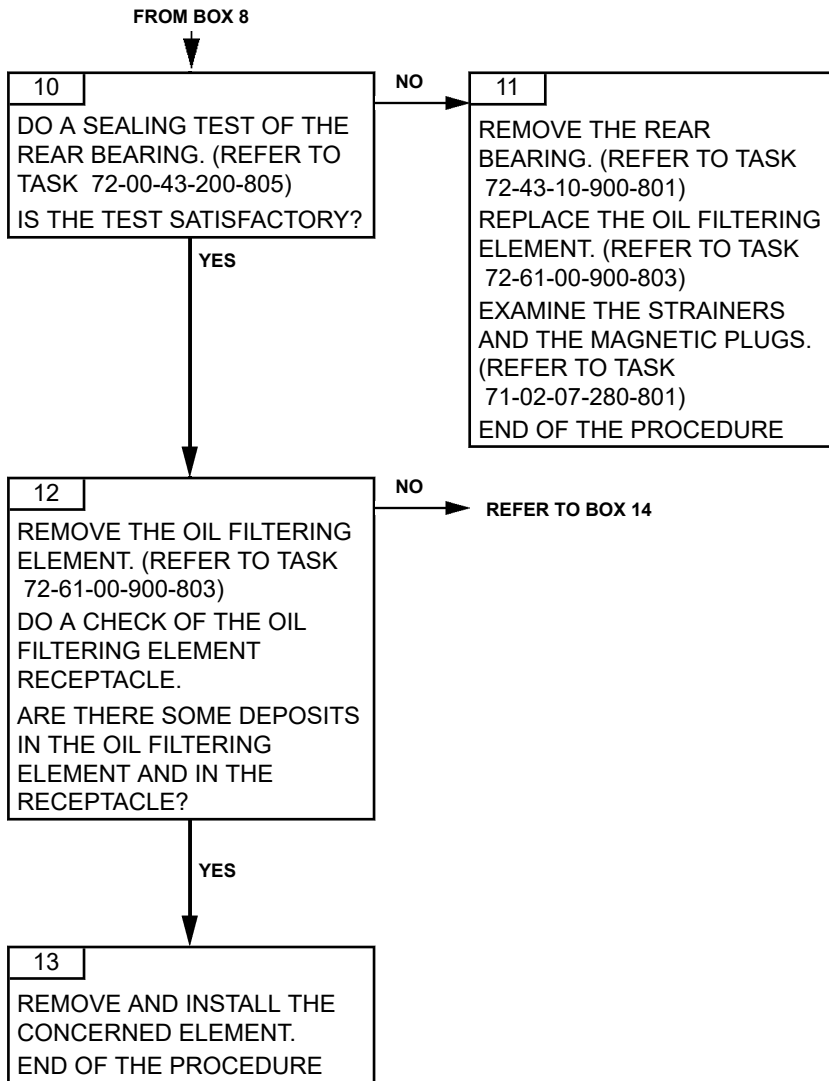

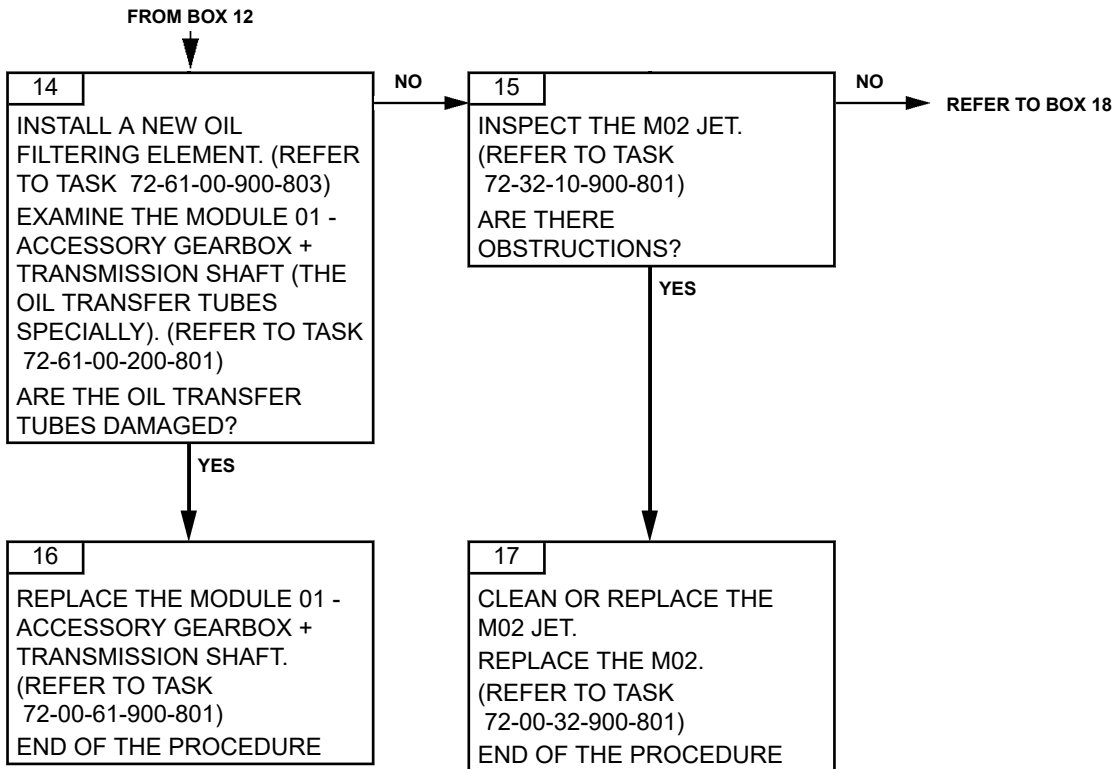

FROM BOX 15

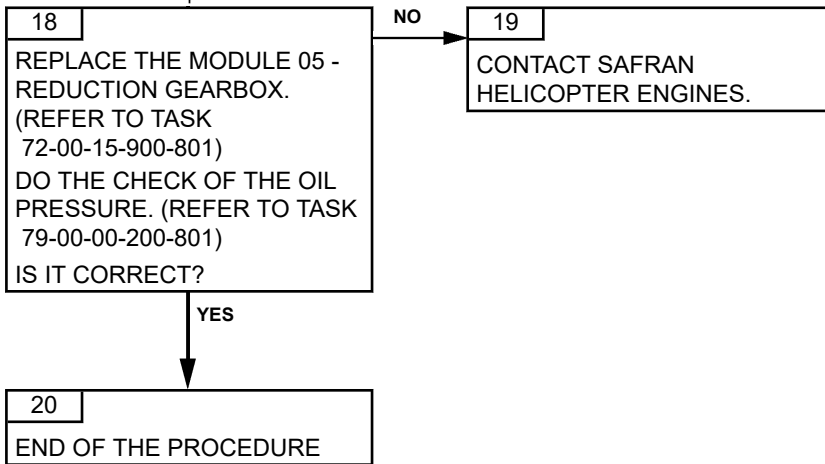

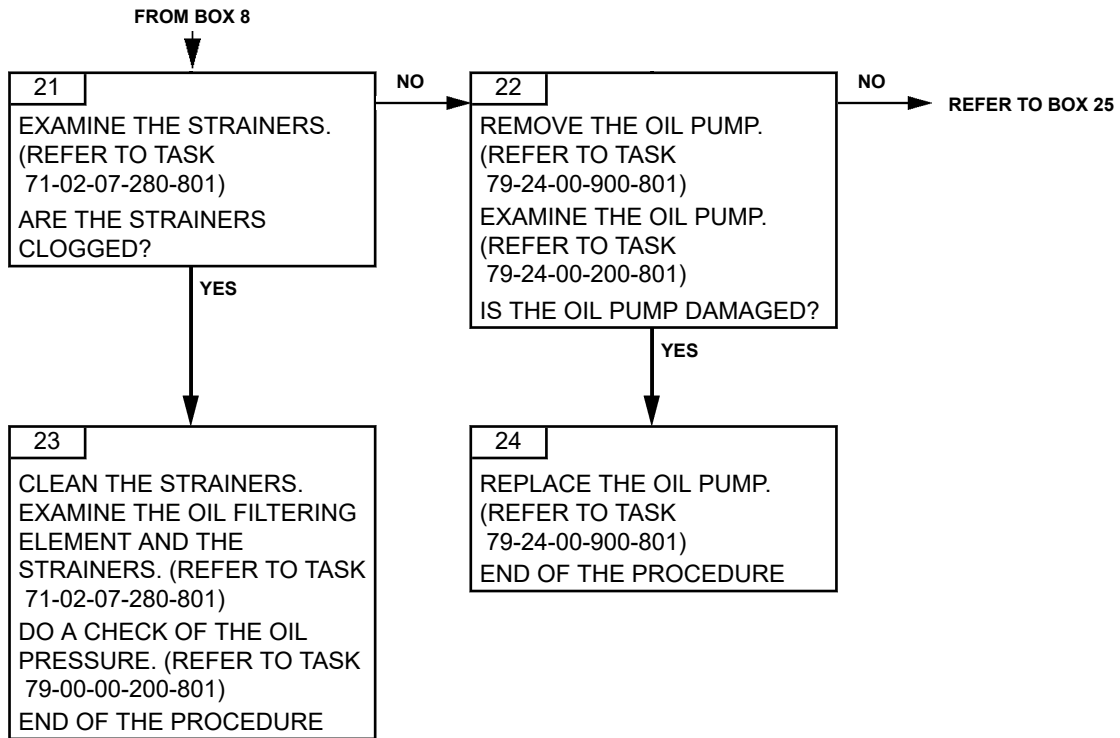

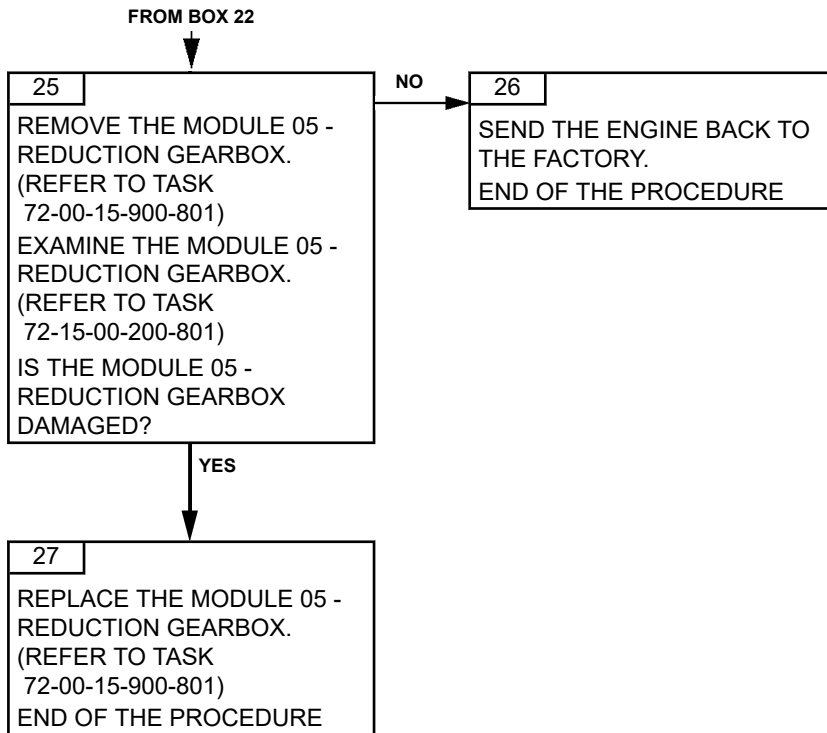

TASK 71-00-06-816-813-A01

**POPPING OUT OF THE PRE-BLOCKAGE INDICATOR
OF THE OIL FILTER
TROUBLESHOOTING**

1. GENERAL

A. GENERAL DESCRIPTION

- The pre-blockage indicator of the oil filter must always be ARMED (not apparent).

B. POSSIBLE CAUSES

- Pre-blockage indicator of the oil filter
- Oil system contamination.

2. PROCEDURE

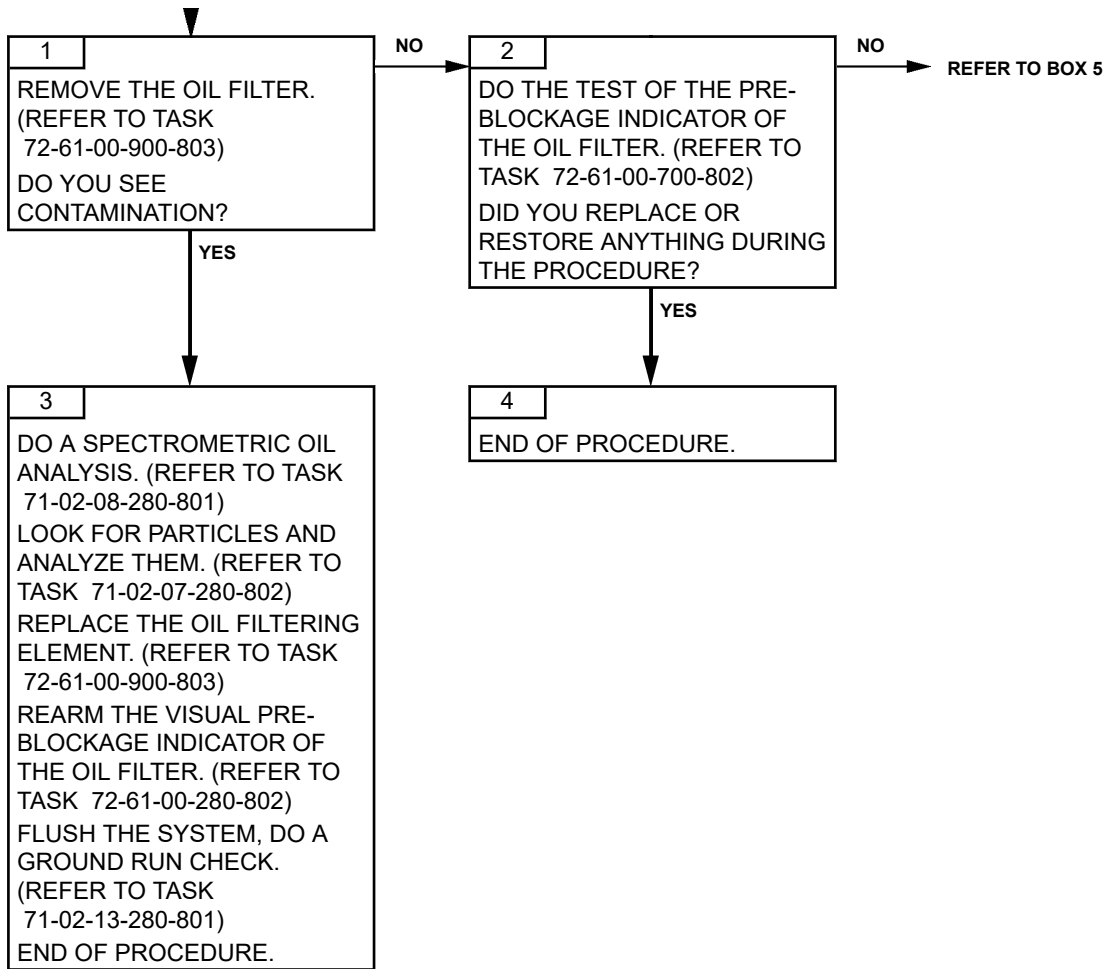

FROM BOX 2



5

DO A SPECTROMETRIC OIL ANALYSIS. (REFER TO TASK 71-02-08-280-801)

LOOK FOR PARTICLES AND ANALYZE THEM. (REFER TO TASK 71-02-07-280-802)

REPLACE THE OIL FILTERING ELEMENT. (REFER TO TASK 72-61-00-900-803)

REARM THE VISUAL PRE-BLOCKAGE INDICATOR OF THE OIL FILTER. (REFER TO TASK 72-61-00-280-802)

FLUSH THE SYSTEM, DO A GROUND RUN CHECK. (REFER TO TASK 71-02-13-280-801)

END OF PROCEDURE.

PAGE LEFT BLANK INTENTIONALLY

TASK 71-00-06-816-814-A01

OIL LEAKAGE BETWEEN M03 AND M04 TROUBLESHOOTING

1. GENERAL

I A. GENERAL DESCRIPTION

- No leakage finding after visual inspection and the engine compartment floor. Refer to chapter 05.

B. POSSIBLE CAUSES

- Wear on the preformed packing at the top of the oil inlet duct
- Defective sealing at the copper seal of the duct at the rear bearing box
- Defective sealing of the preformed packings of the oil valve assembly

2. PROCEDURE

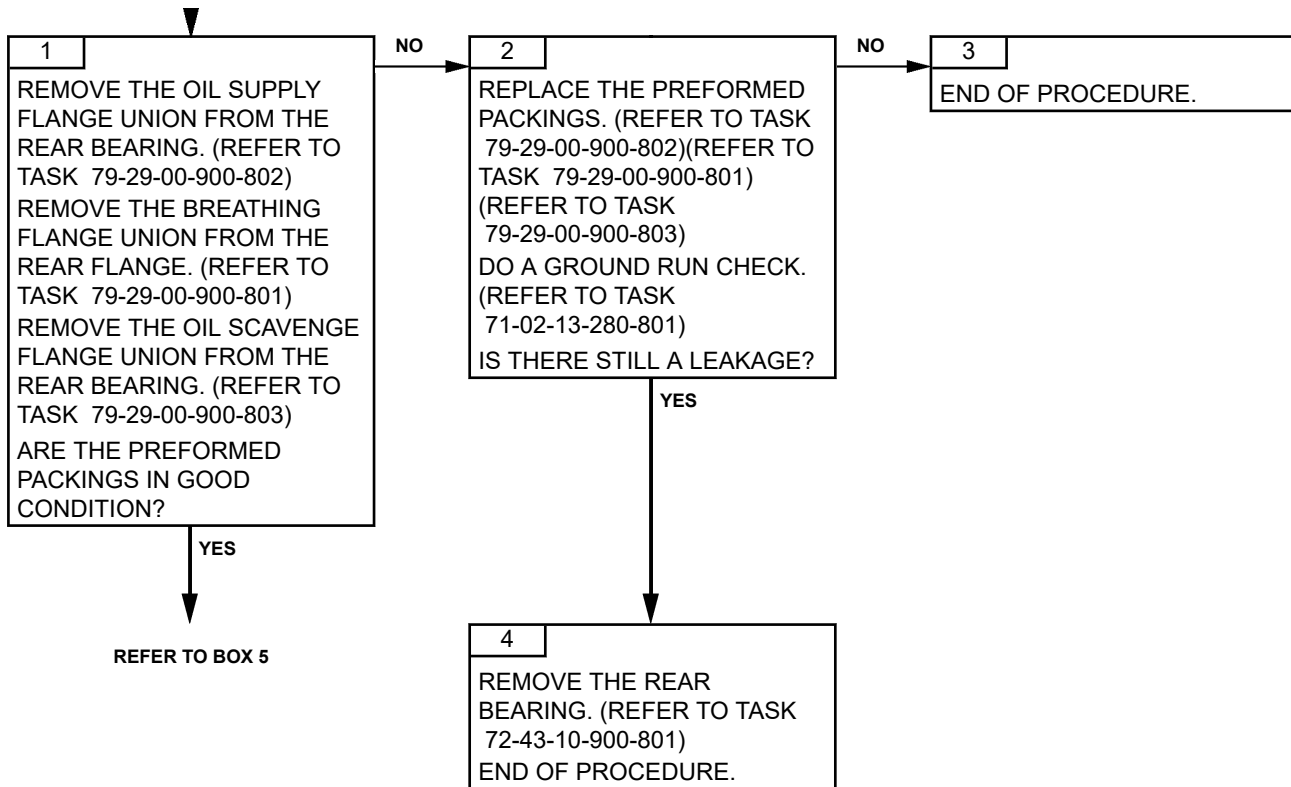

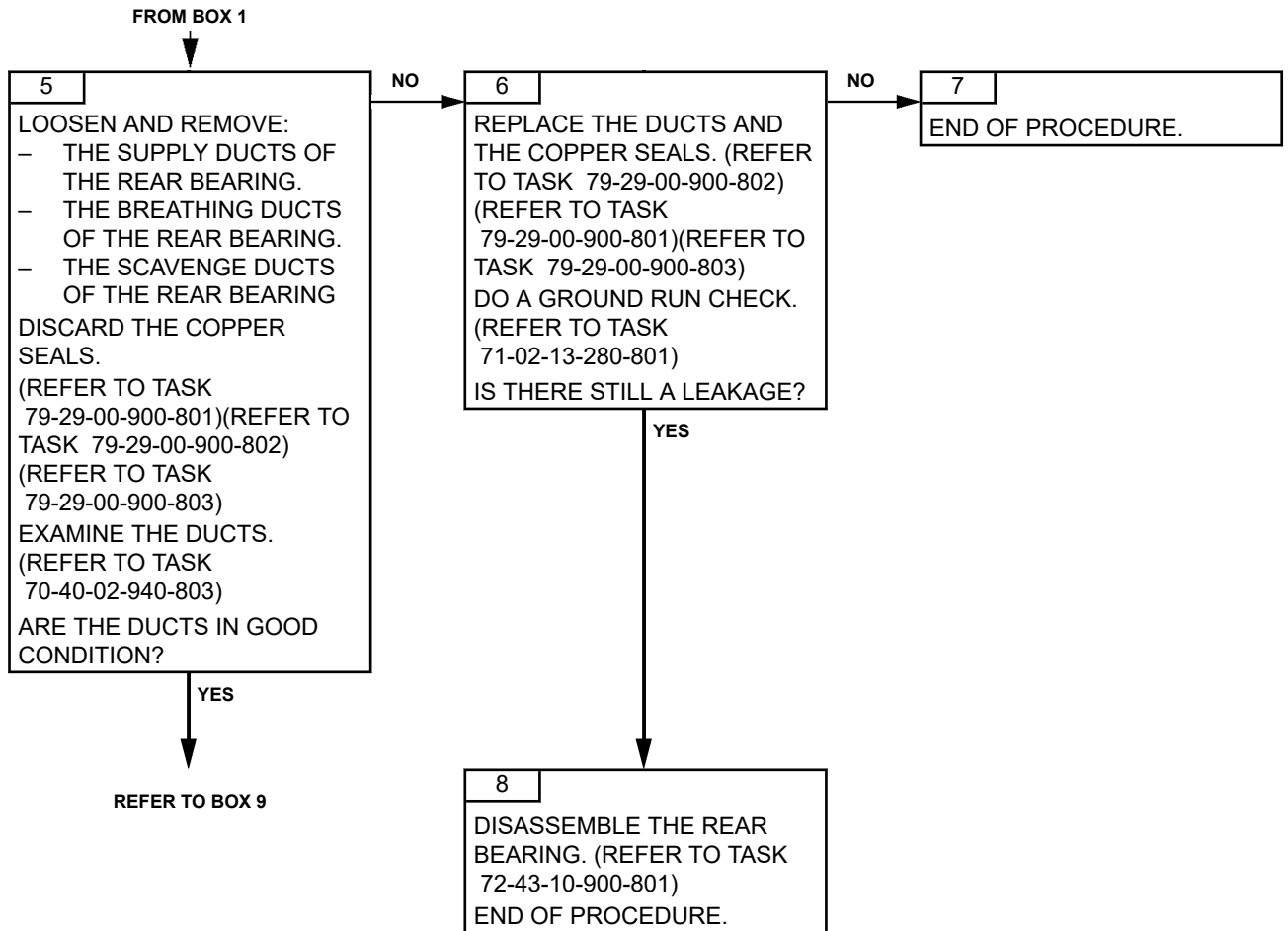

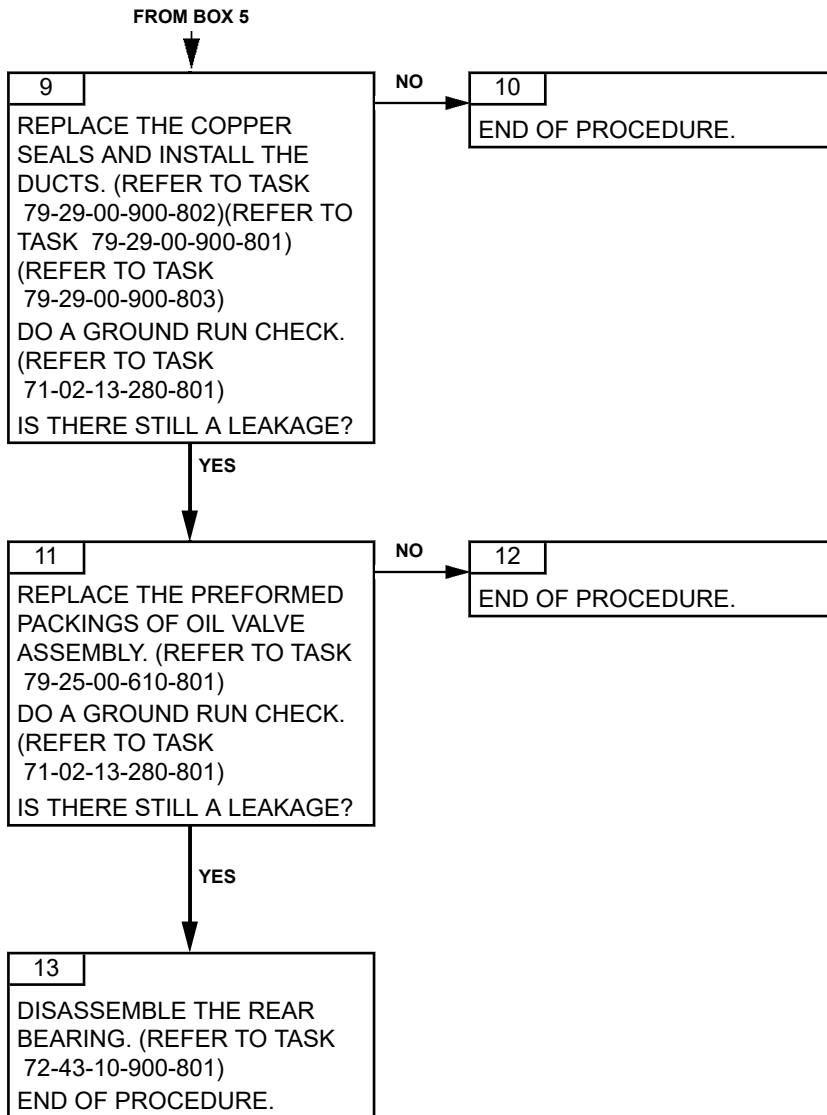

ARRIEL 2 C1

TASK 71-00-06-816-815-A01

VIBRATION OUT OF TOLERANCE DETECTED BY THE M'ARMS SYSTEM TROUBLESHOOTING

1. GENERAL

A. FAILURE DETECTION CONDITIONS

- The M'ARMS system has detected an out of tolerance vibration level on the turboshaft engine.

B. POSSIBLE CAUSES

- Modules M01, M02, M03, M04, M05
- Starter generator
- Alternator
- Pump and metering unit assembly
- Oil pump
- Output shaft

2. PROCEDURE

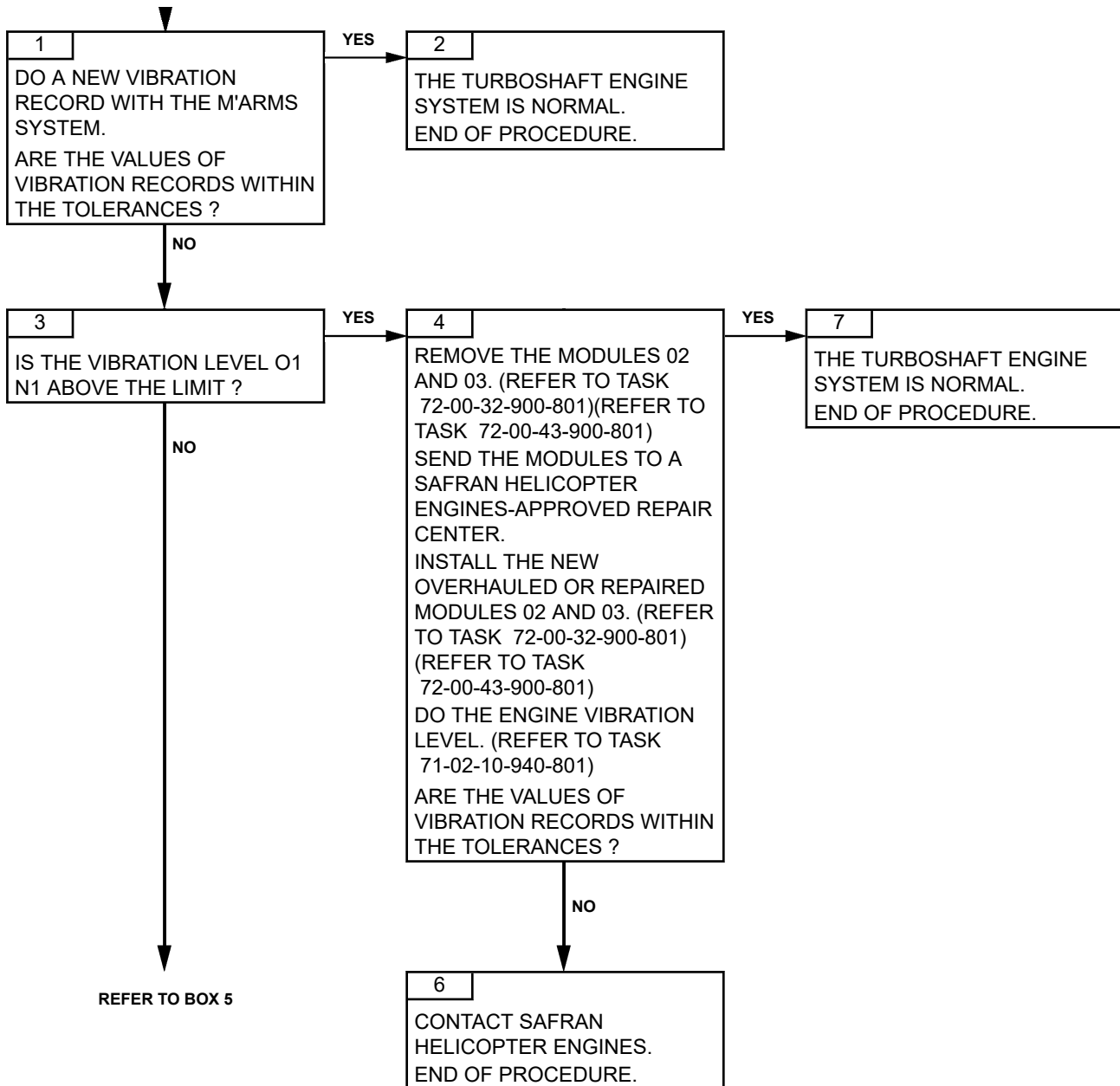

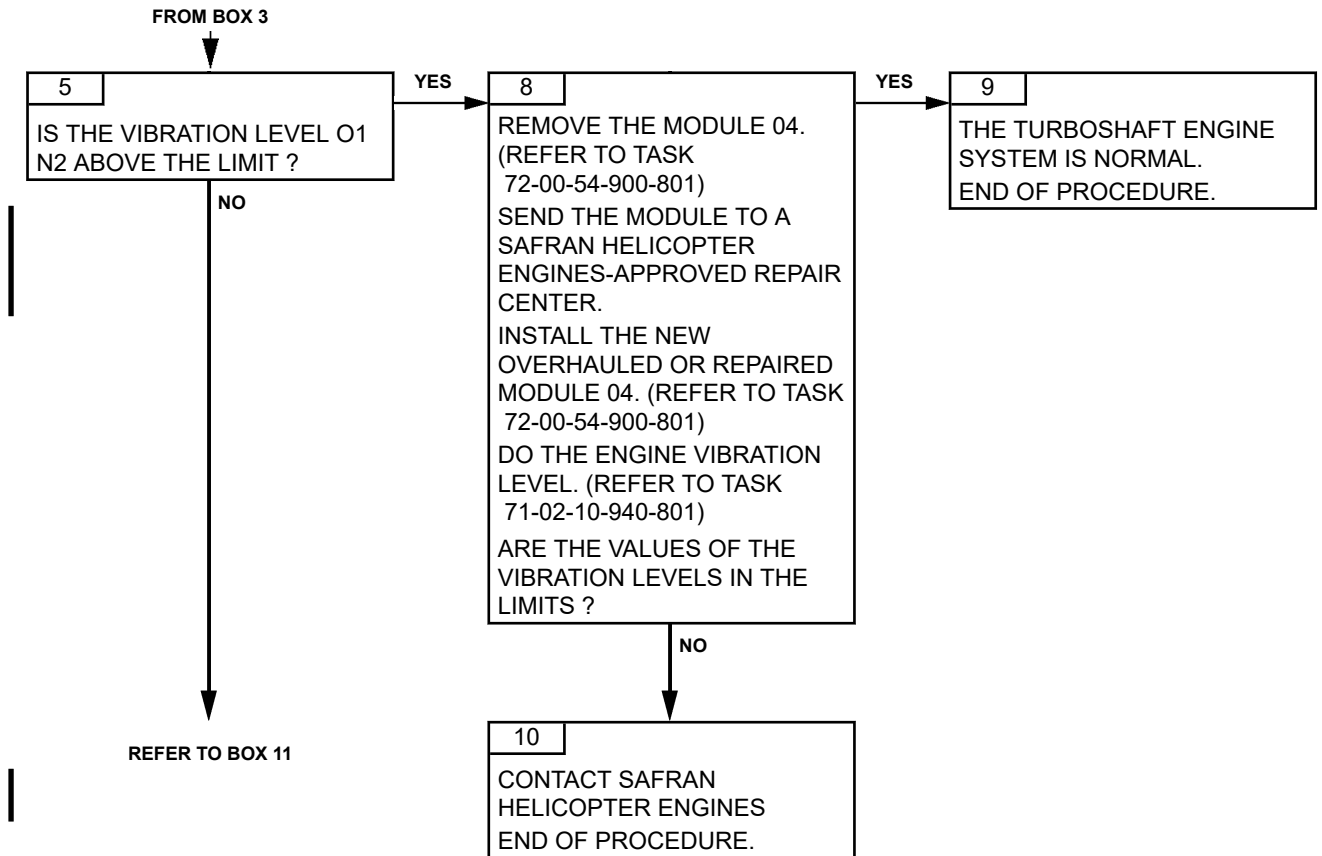

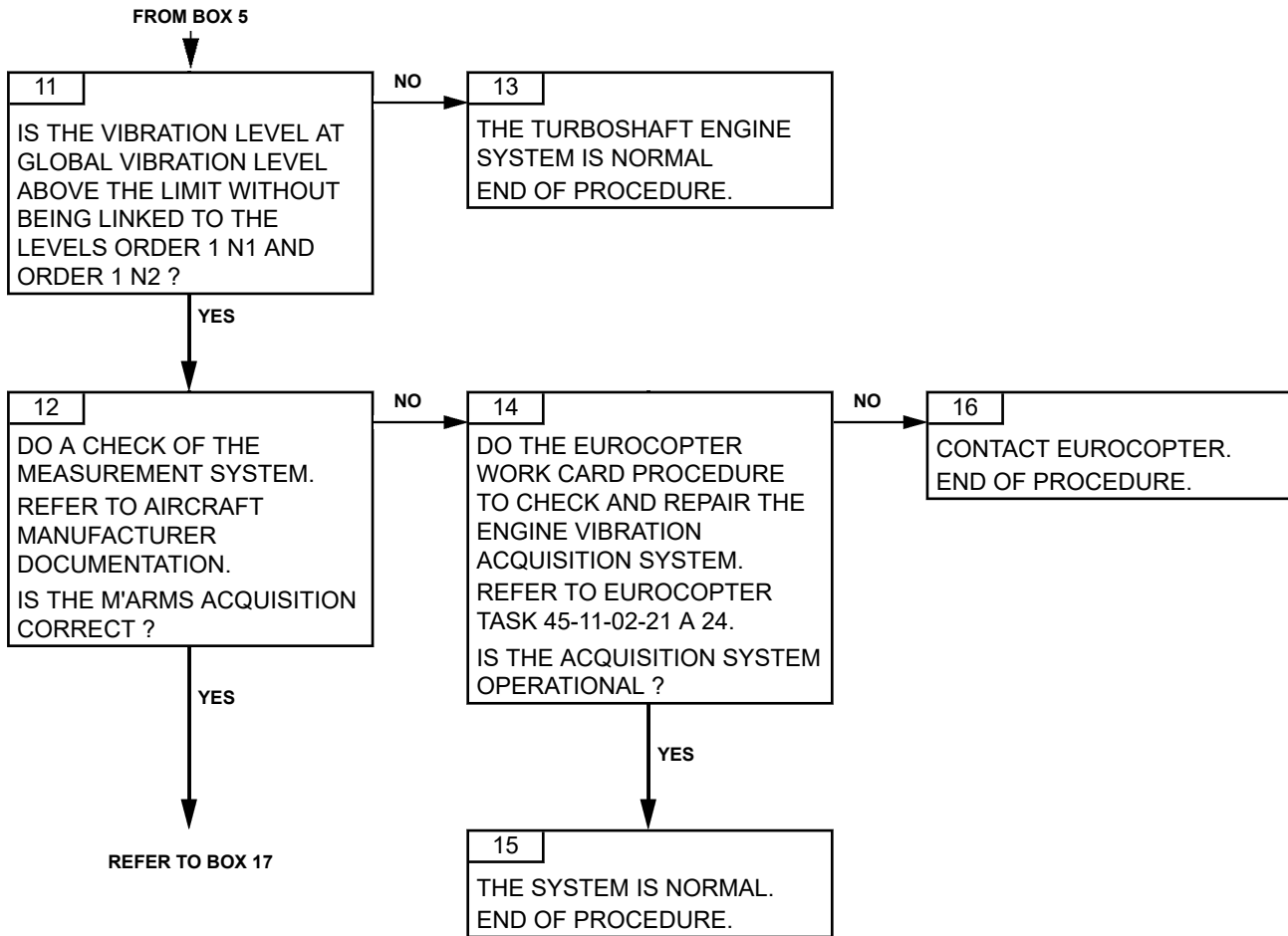

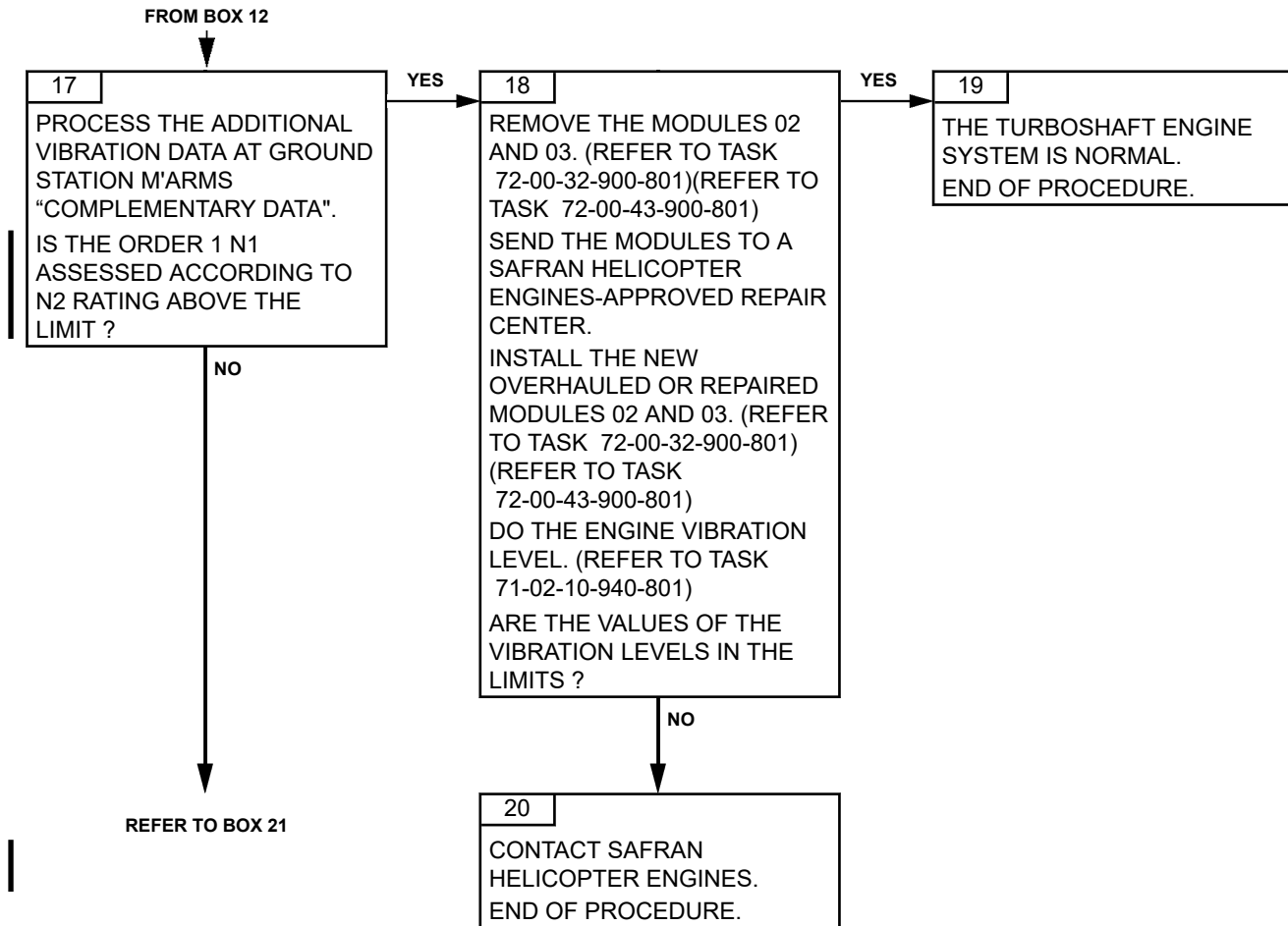

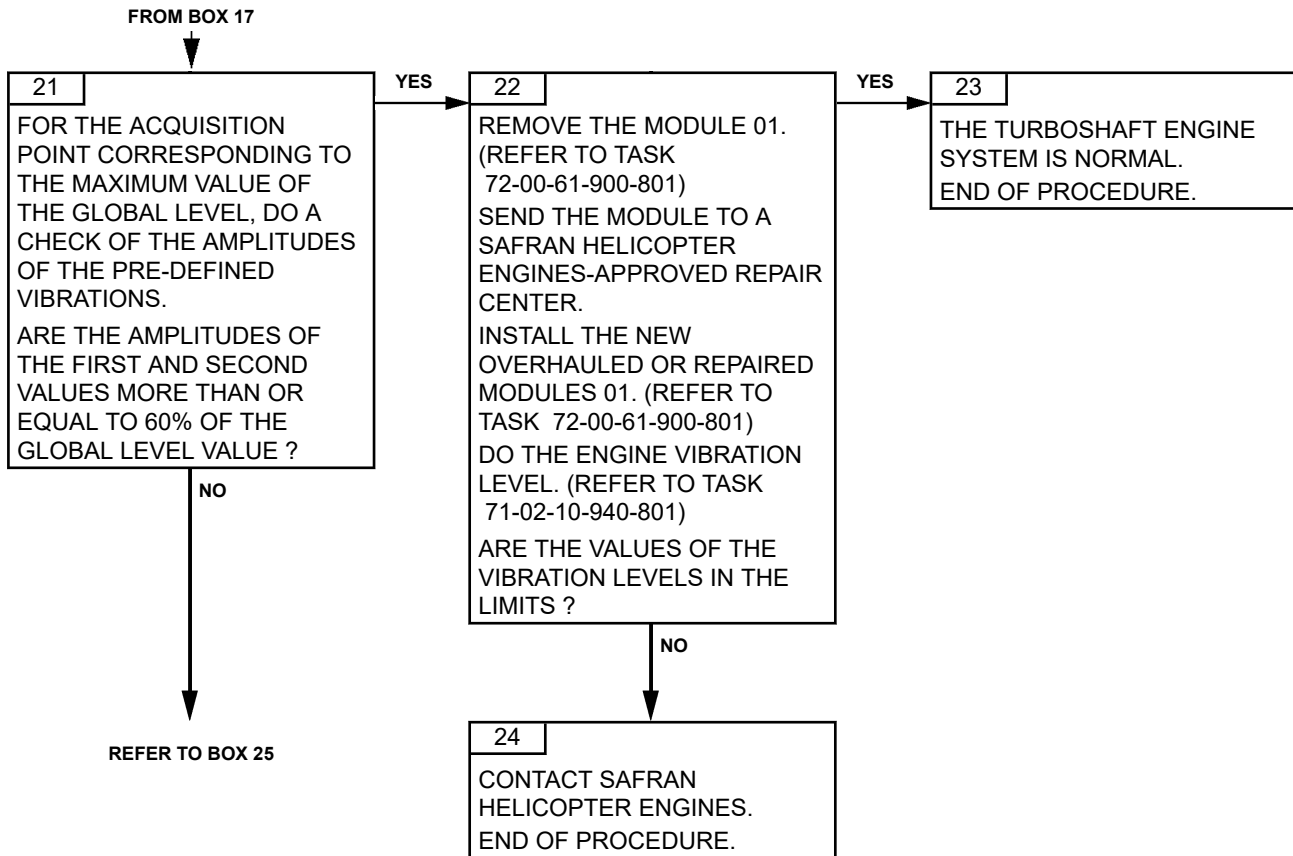

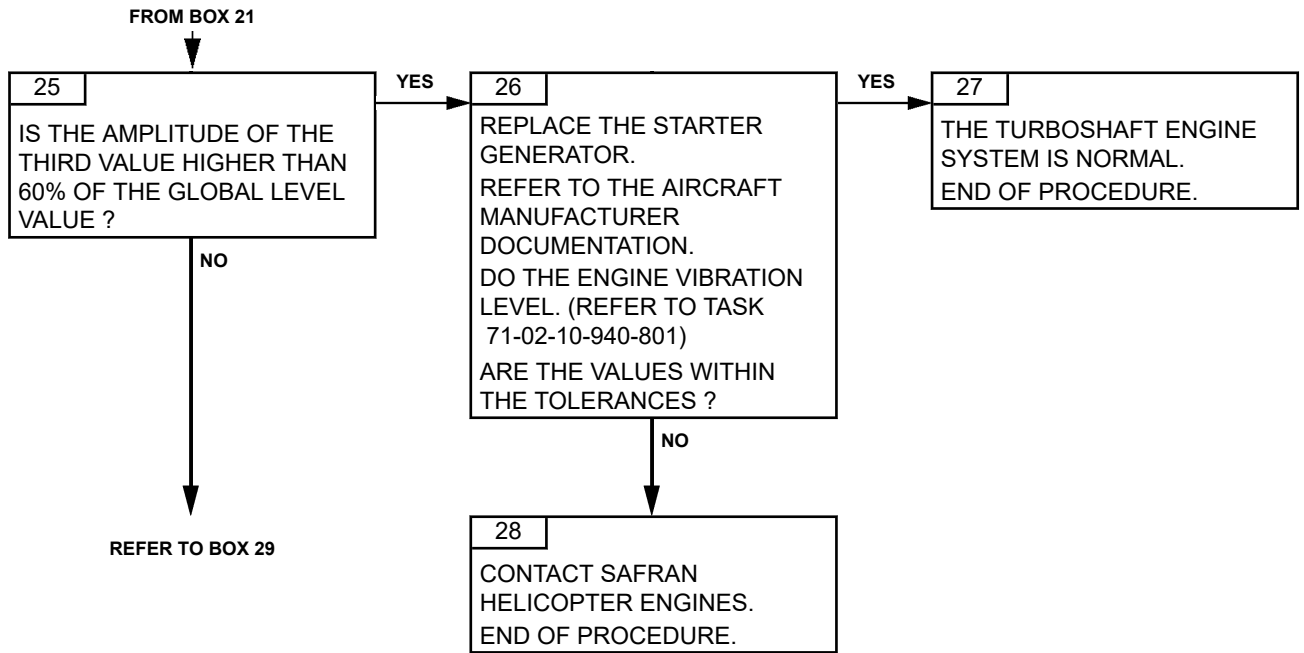

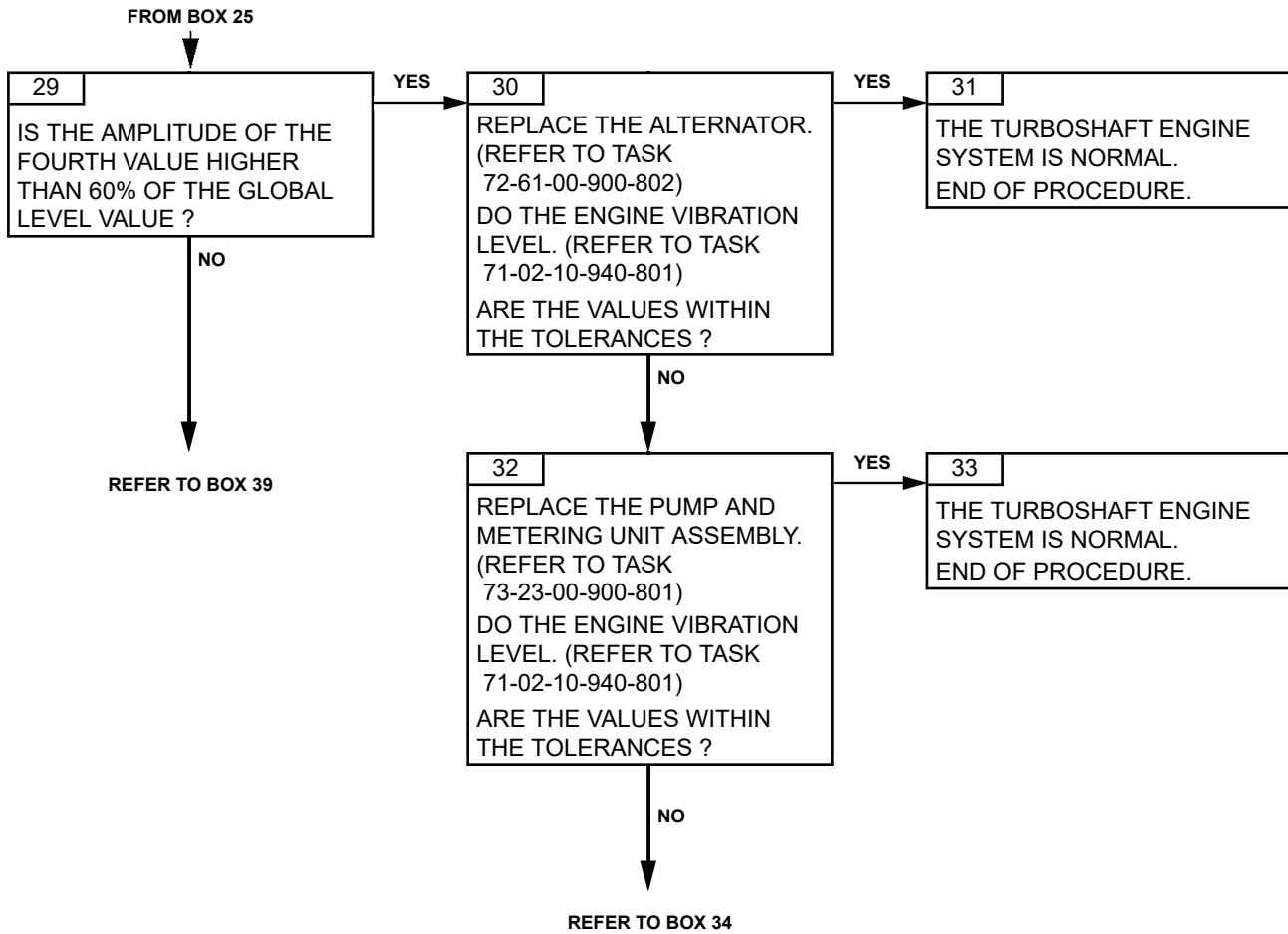

ARRIEL 2 C1

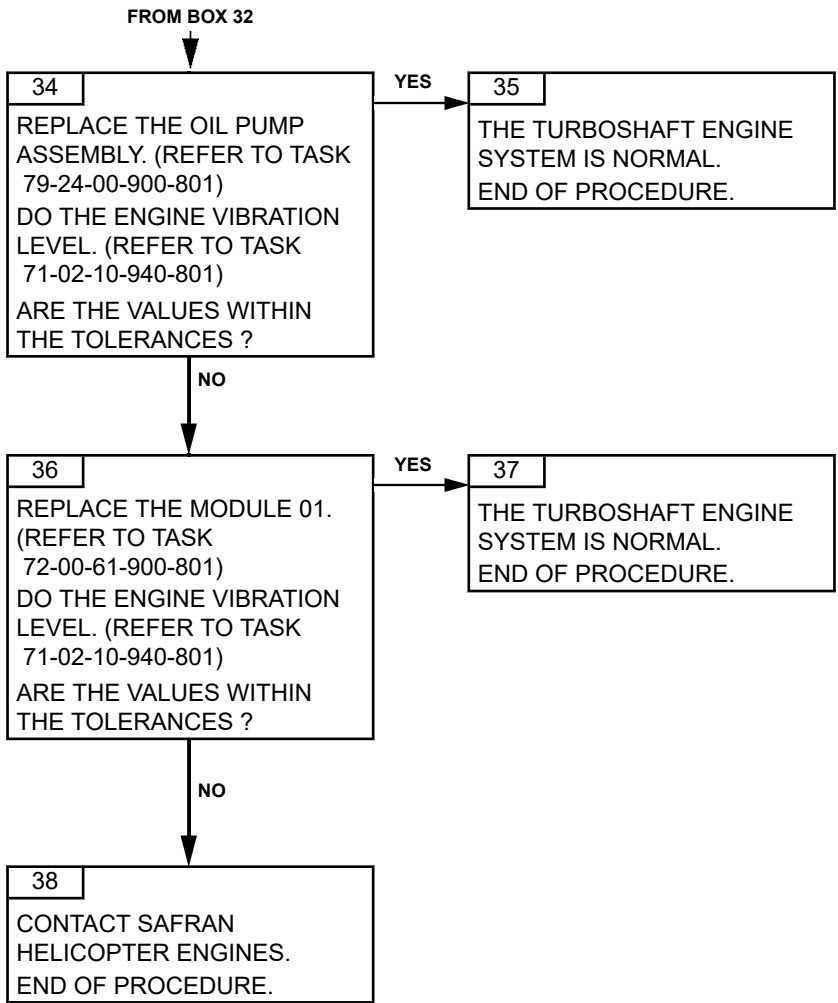

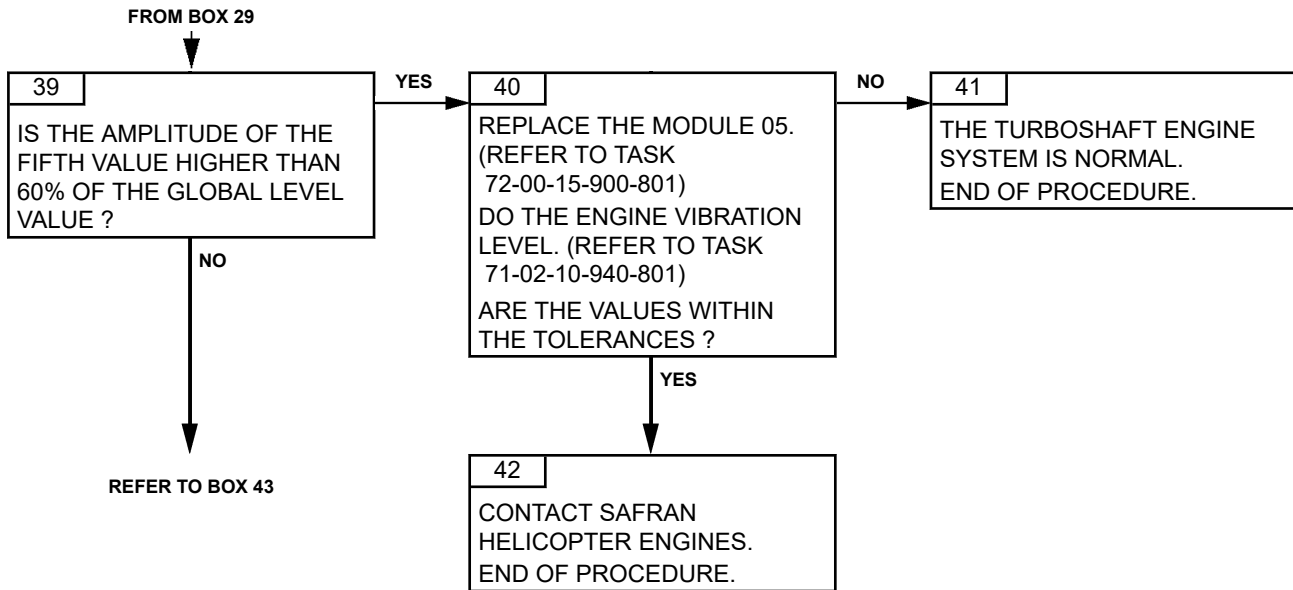

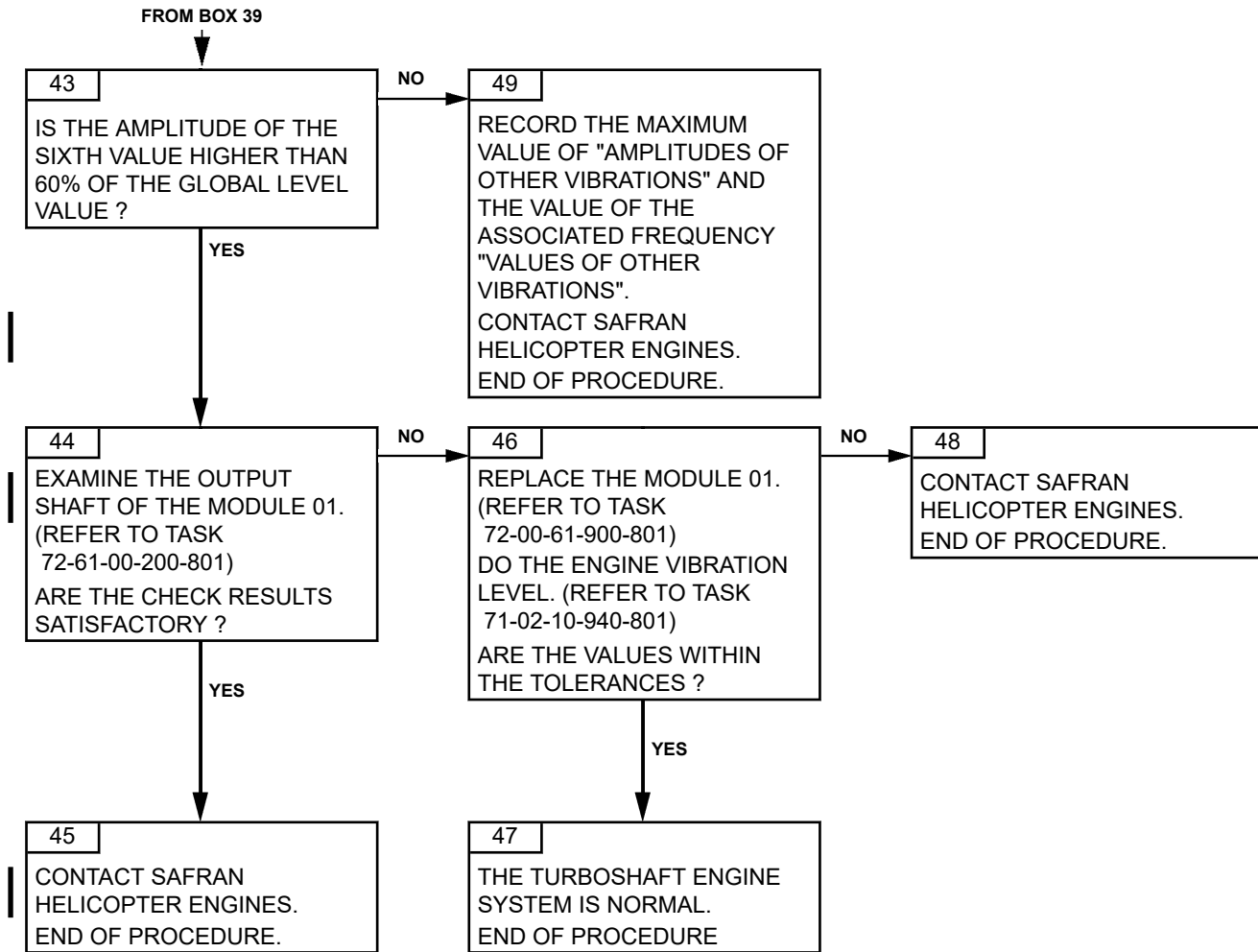

PAGE LEFT BLANK INTENTIONALLY

ARRIEL 2 C1

TASK 71-00-06-816-819-A01

**ENGINE POWER CHECK - INCORRECT MARGIN
TROUBLESHOOTING****1. GENERAL****A. INDICATION ON THE AVIONIC**

The engine power check is incorrect.

B. GENERAL DESCRIPTION

Monitoring of in-service performance is a great help for engine health assessment. Trend monitoring improves troubleshooting through interpretation of performance and degradation localization. (Refer to Task 71-02-14-940-801).

CAUTION: MAKE SURE THAT THE CONCERNED AIRCRAFT SYSTEM IS SERVICEABLE BEFORE ANY INTERVENTION ON THE ENGINE.

C. POSSIBLE CAUSES

- T45 conformation
- Torque conformation
- Torque sensor
- Control harness
- Pyrometric harness
- Module 02 Axial Compressor
- Module 03 Gas Generator (Centrifugal compressor and HP Turbine)
- Module 04 Power Turbine
- Air path fouling
- Air leakage
- Air intake
- P0 aircraft measuring system
- T0 aircraft measuring system

2. PROCEDURE

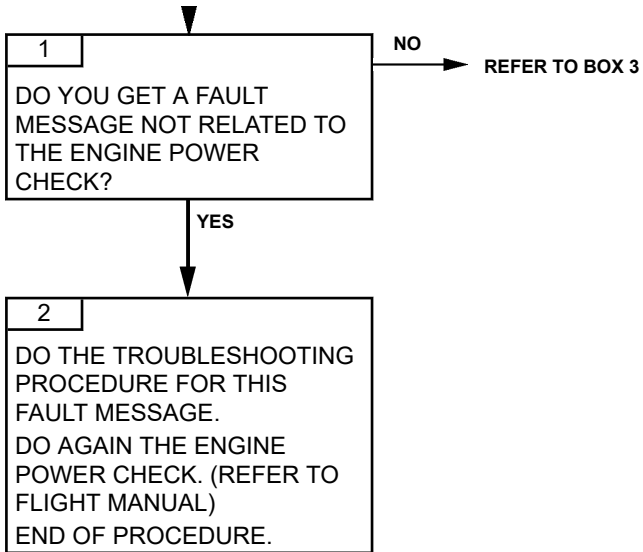

ARRIEL 2 C1

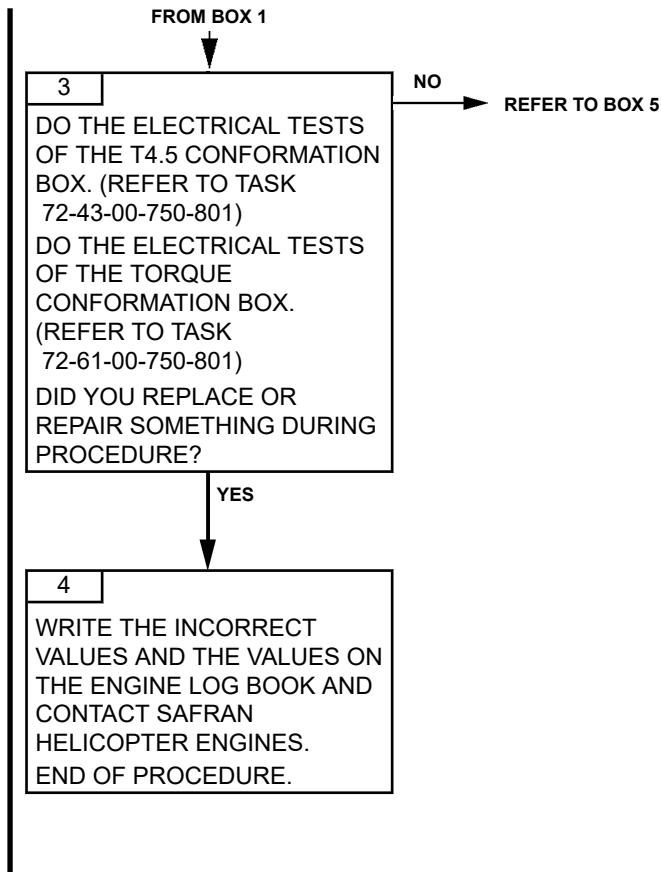

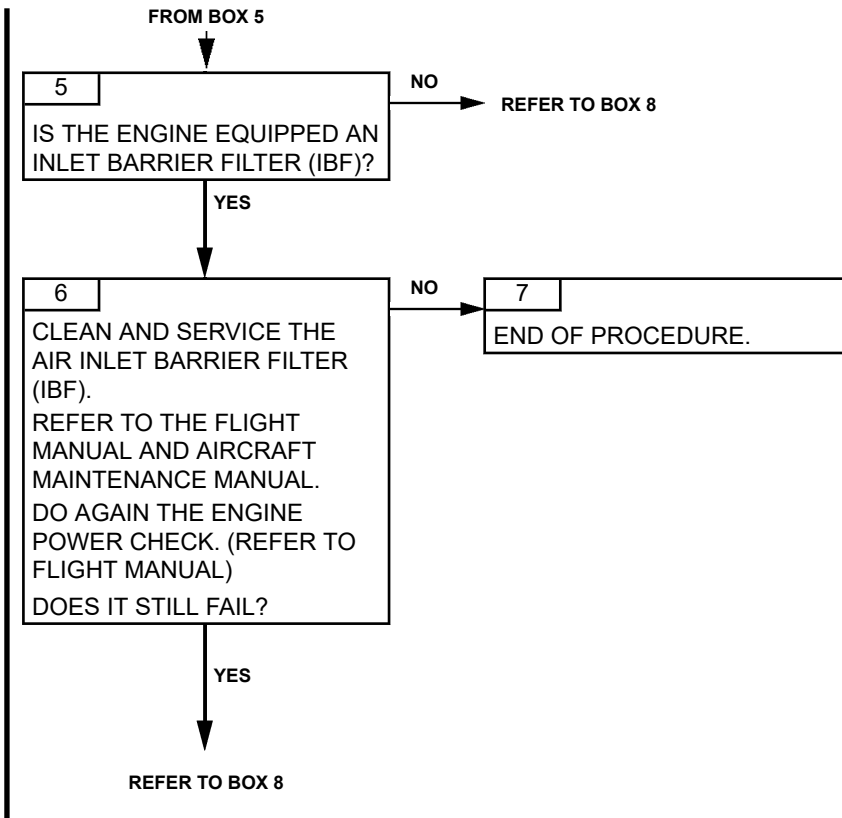

ARRIEL 2 C1

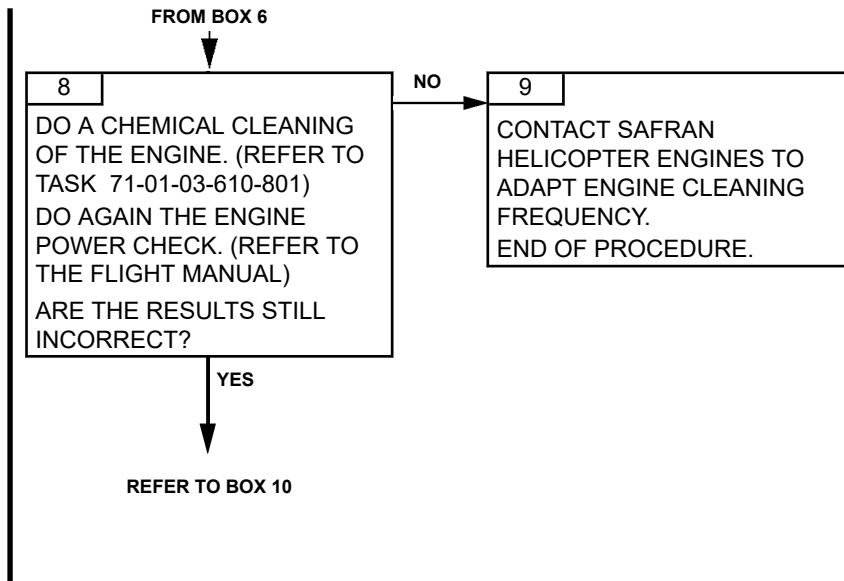

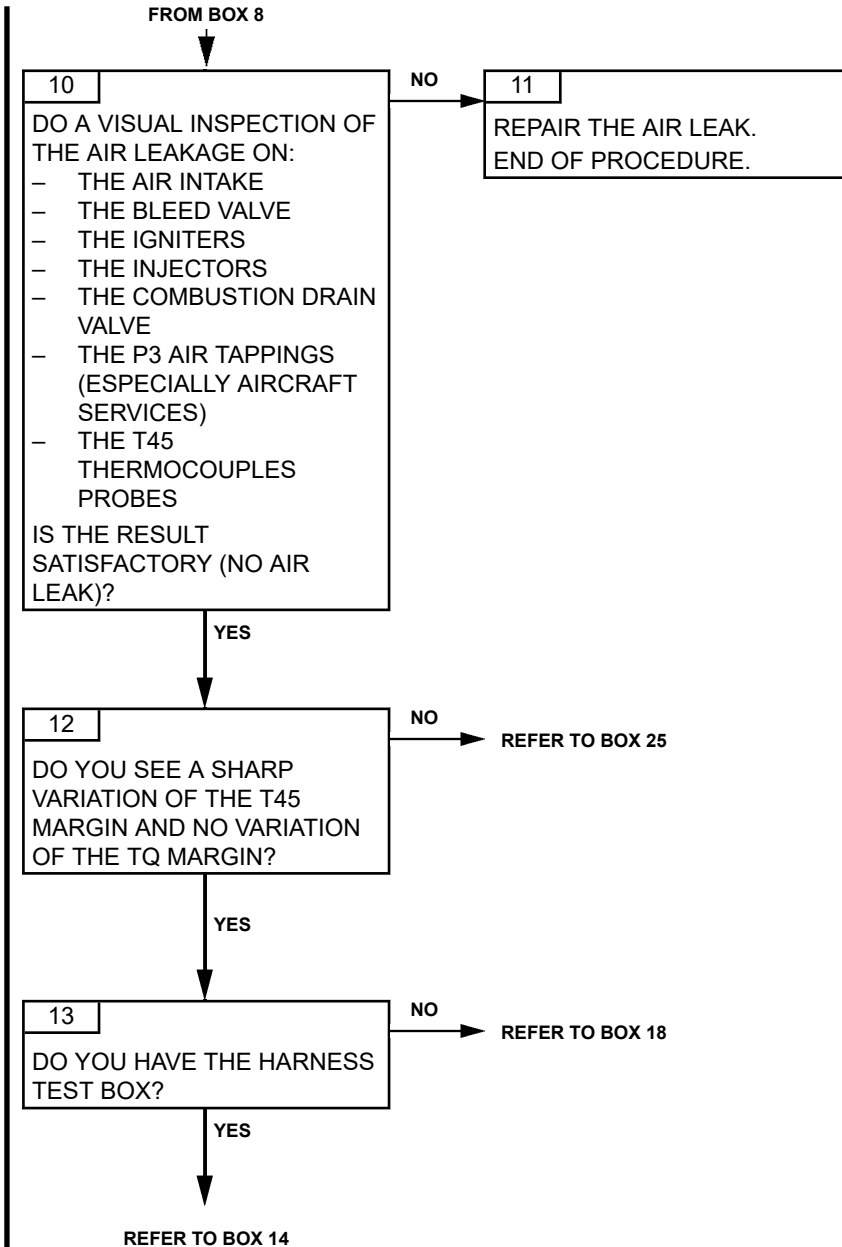

ARRIEL 2 C1

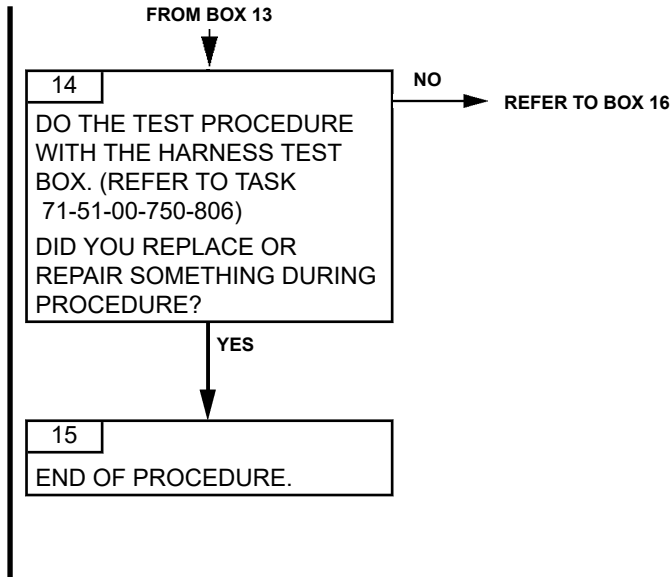

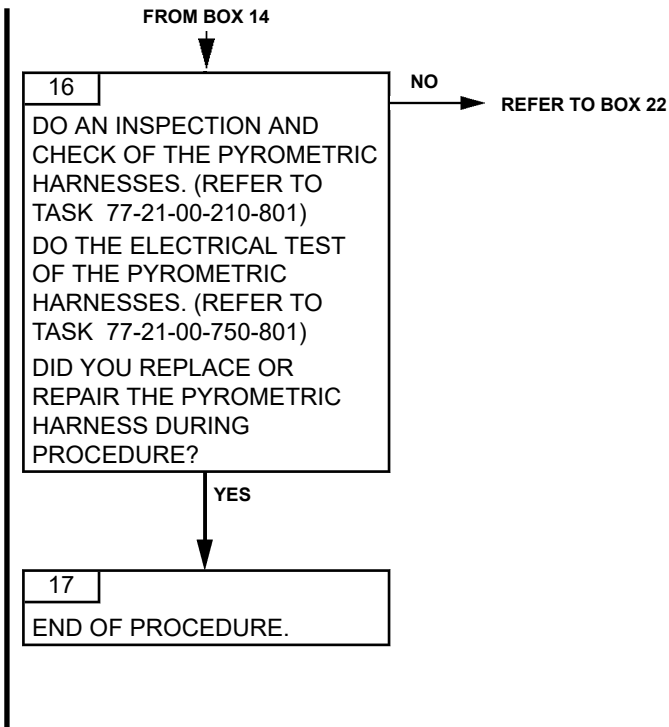

ARRIEL 2 C1

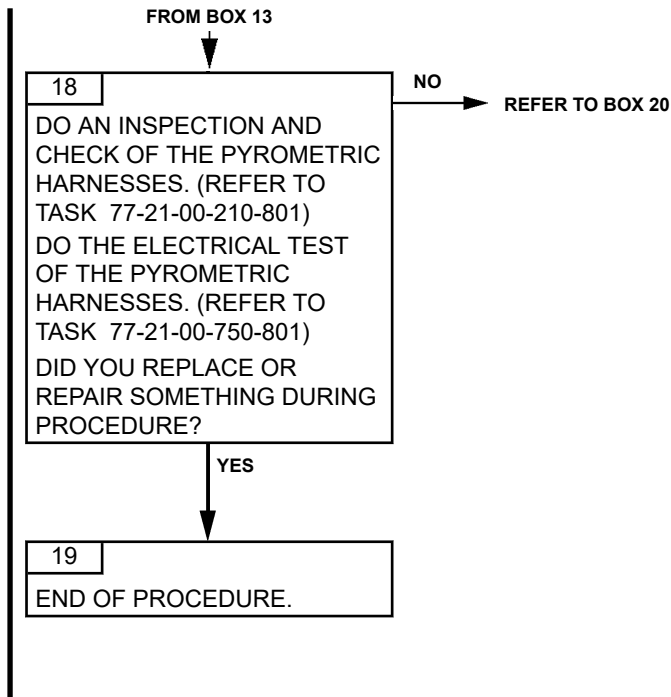

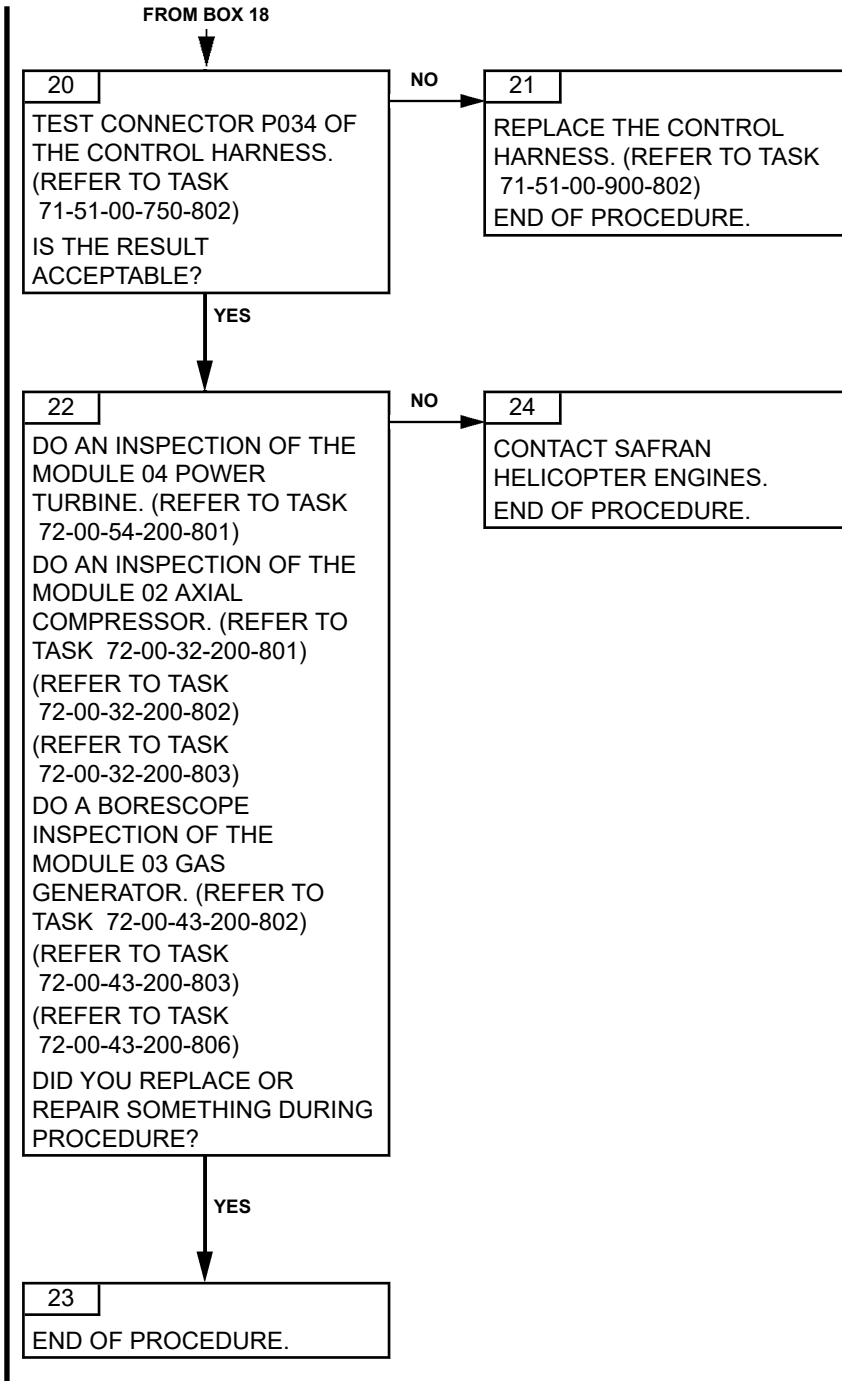

ARRIEL 2 C1

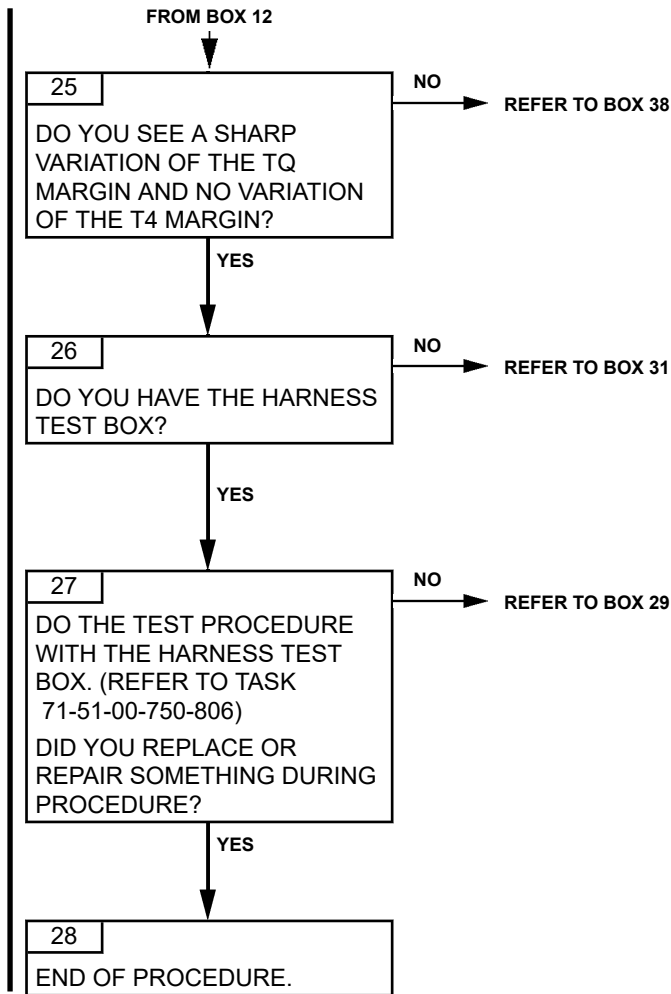

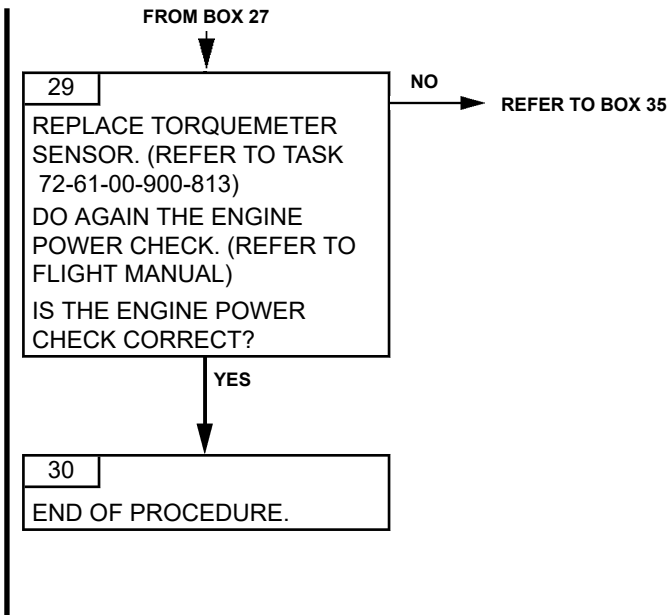

ARRIEL 2 C1

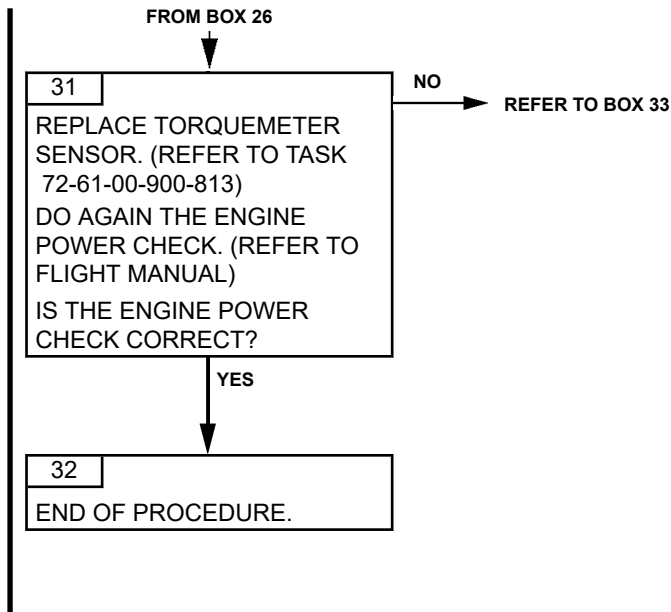

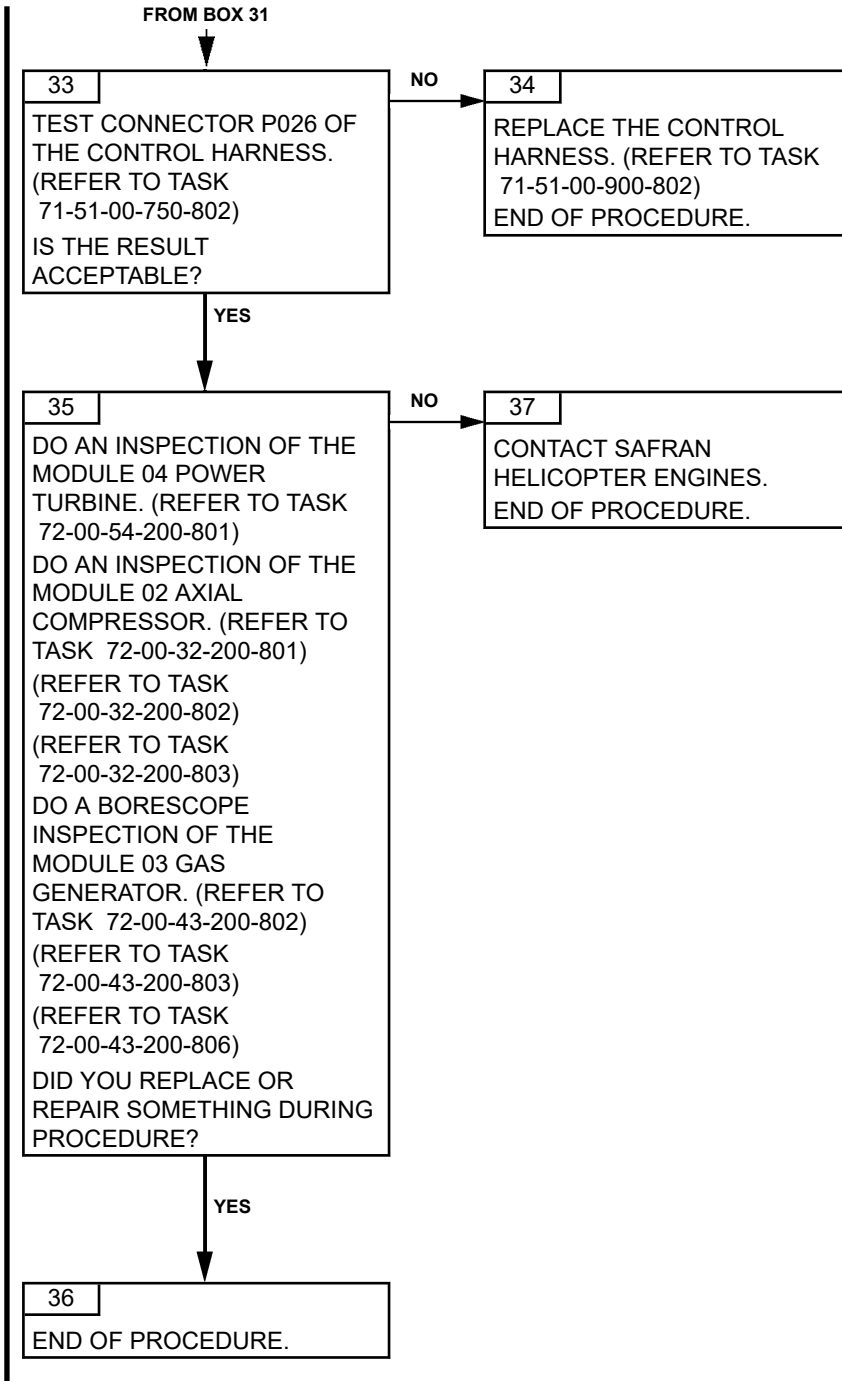

ARRIEL 2 C1

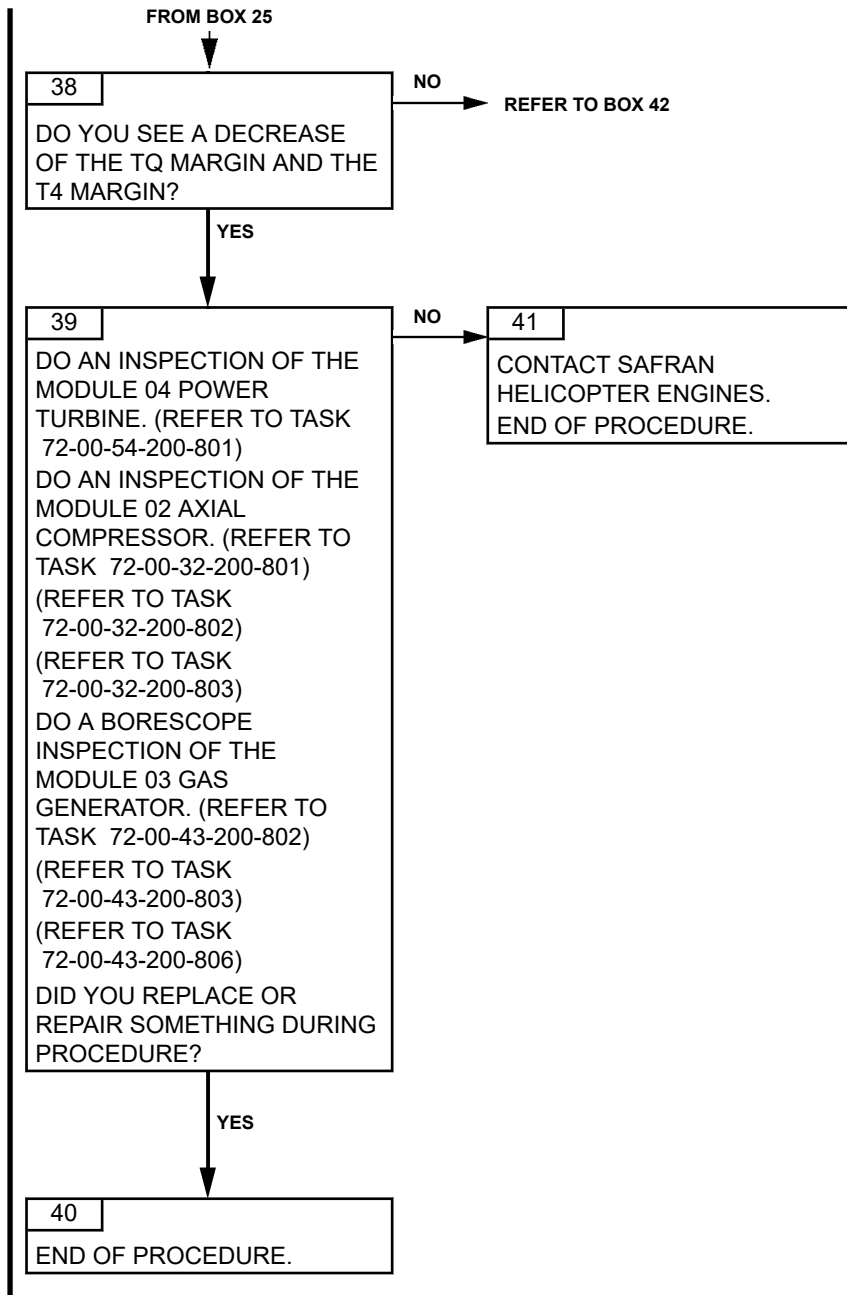

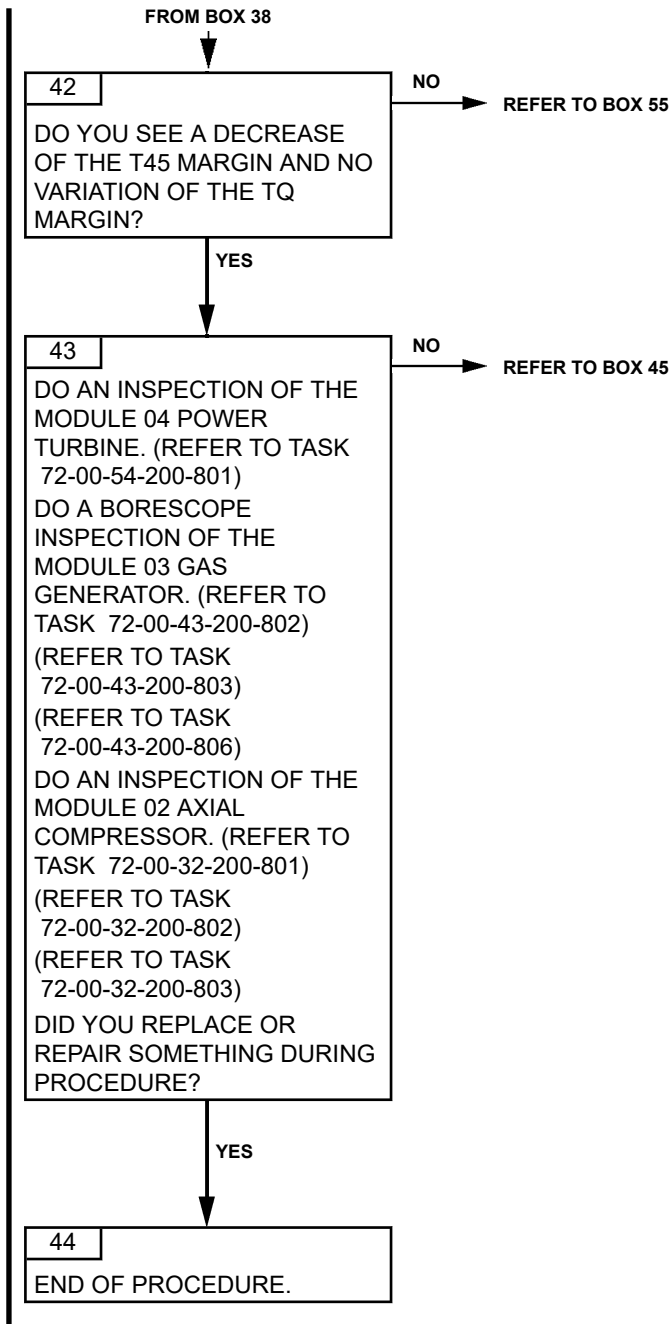

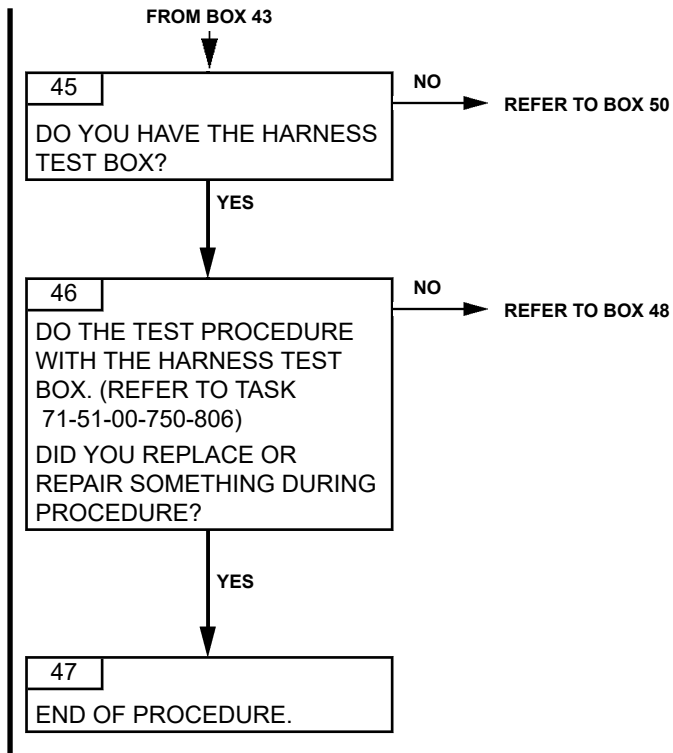

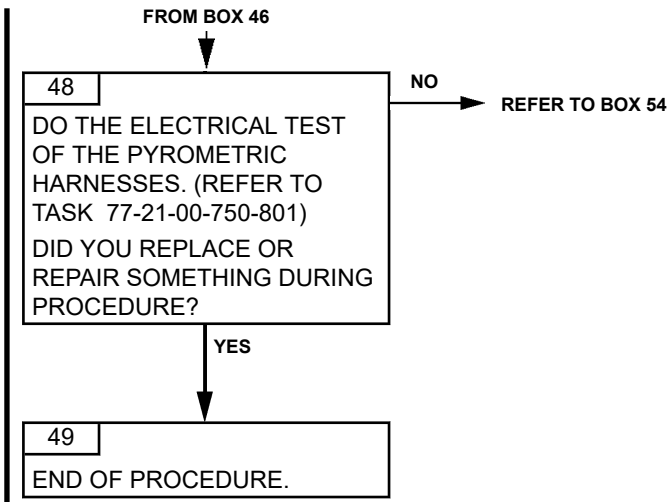

ARRIEL 2 C1

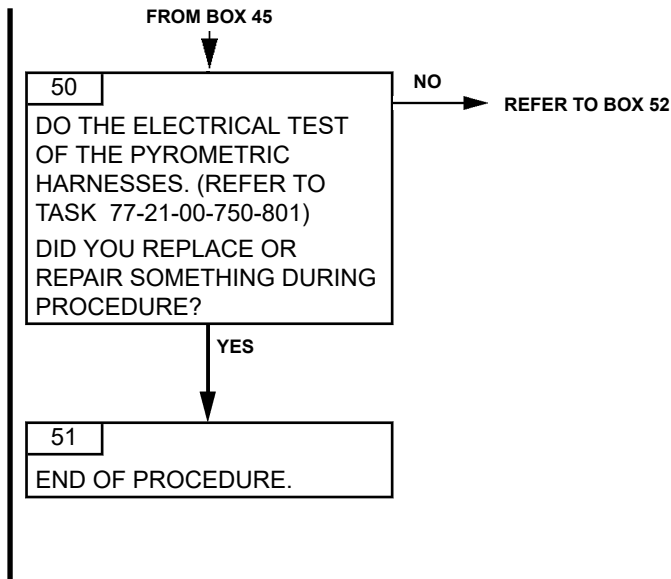

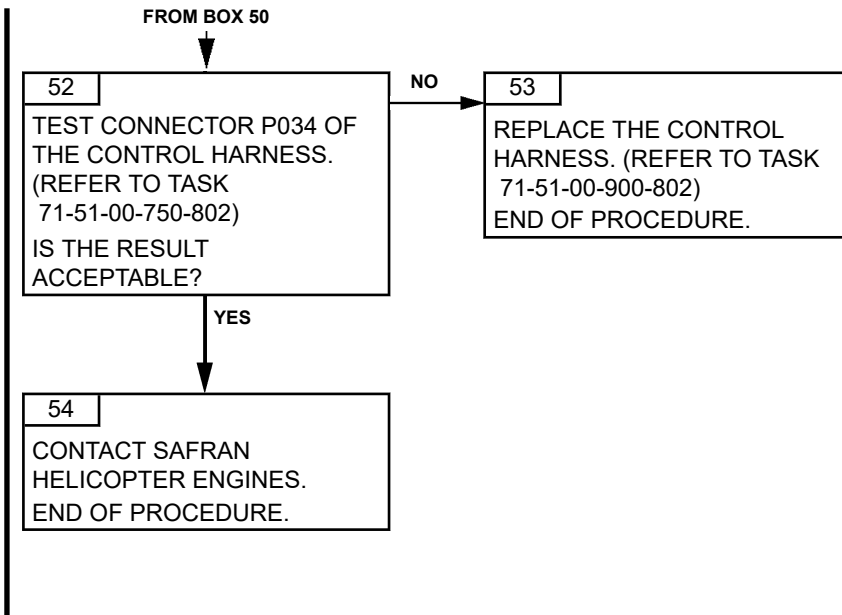

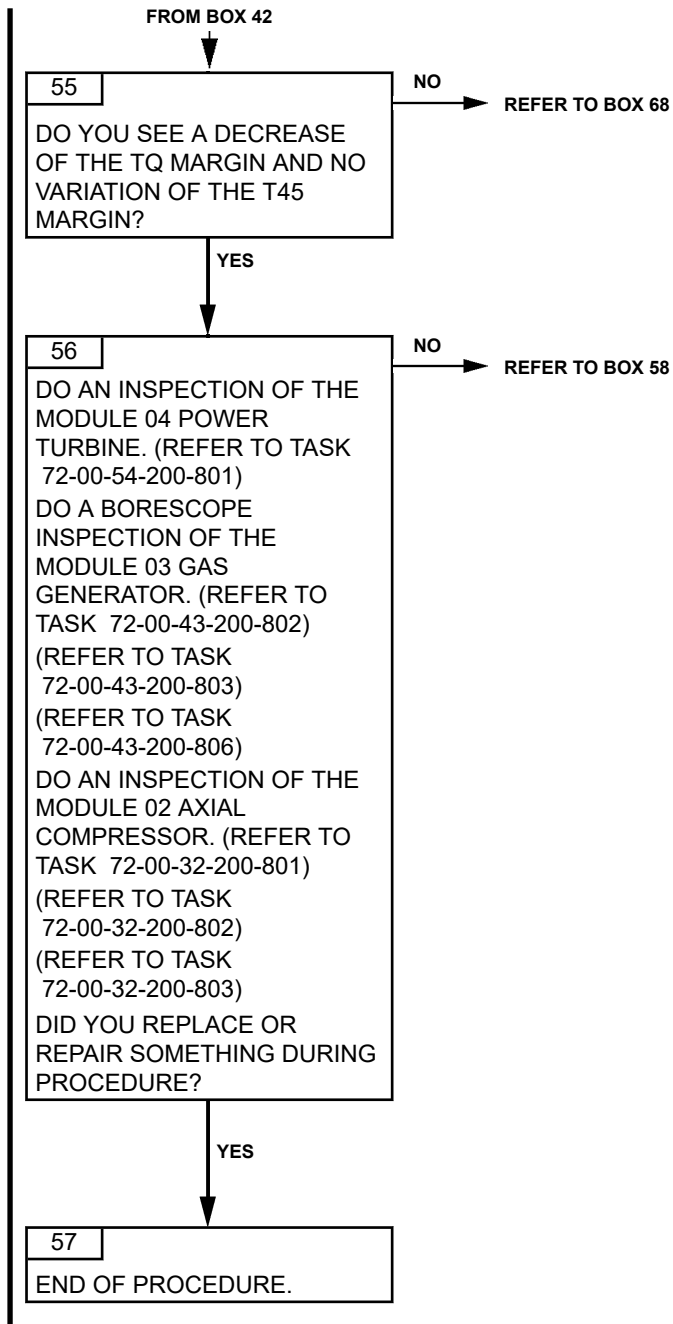

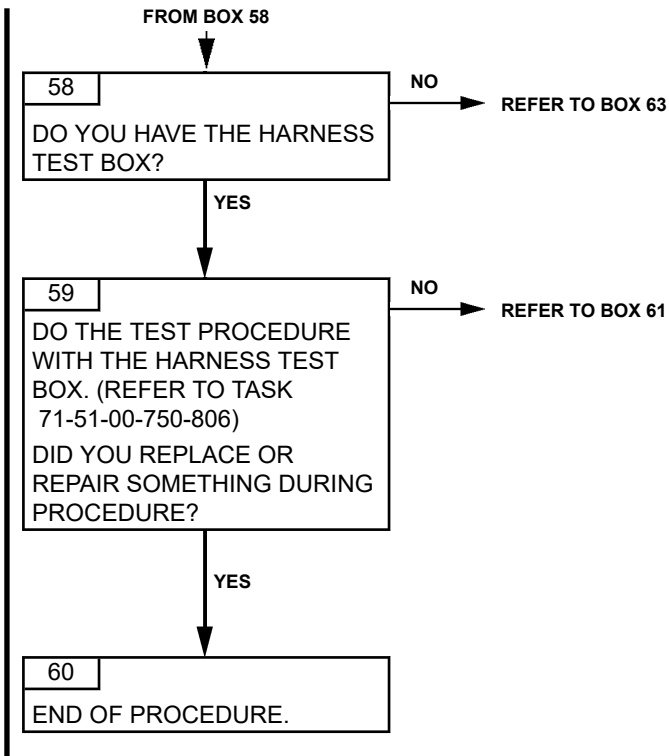

ARRIEL 2 C1

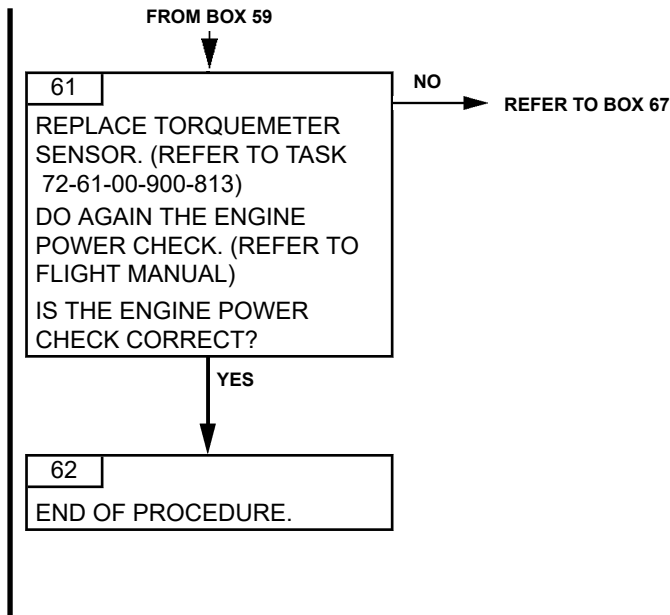

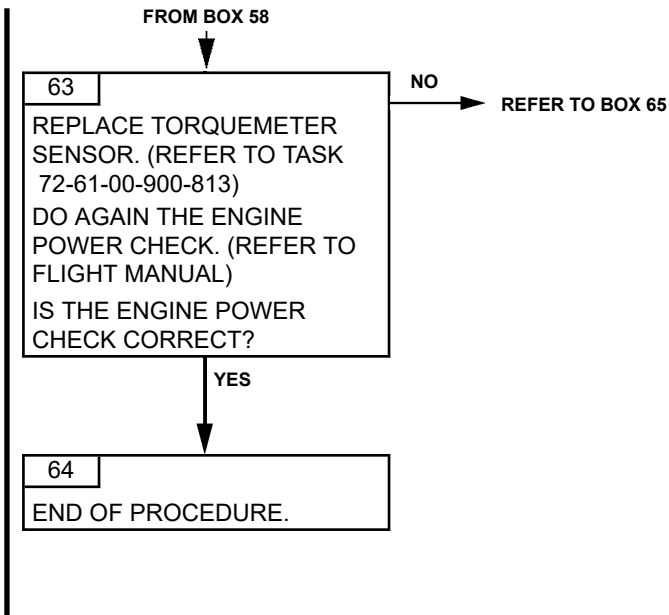

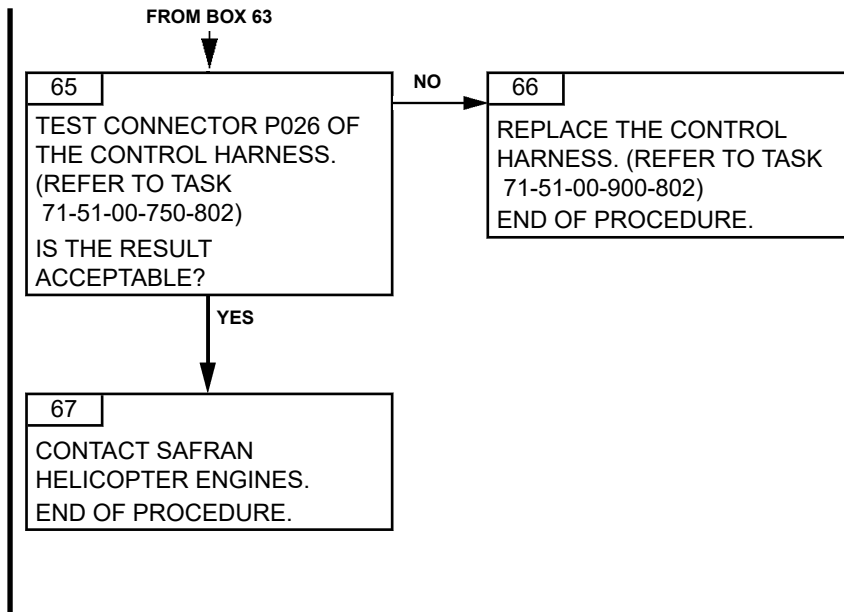

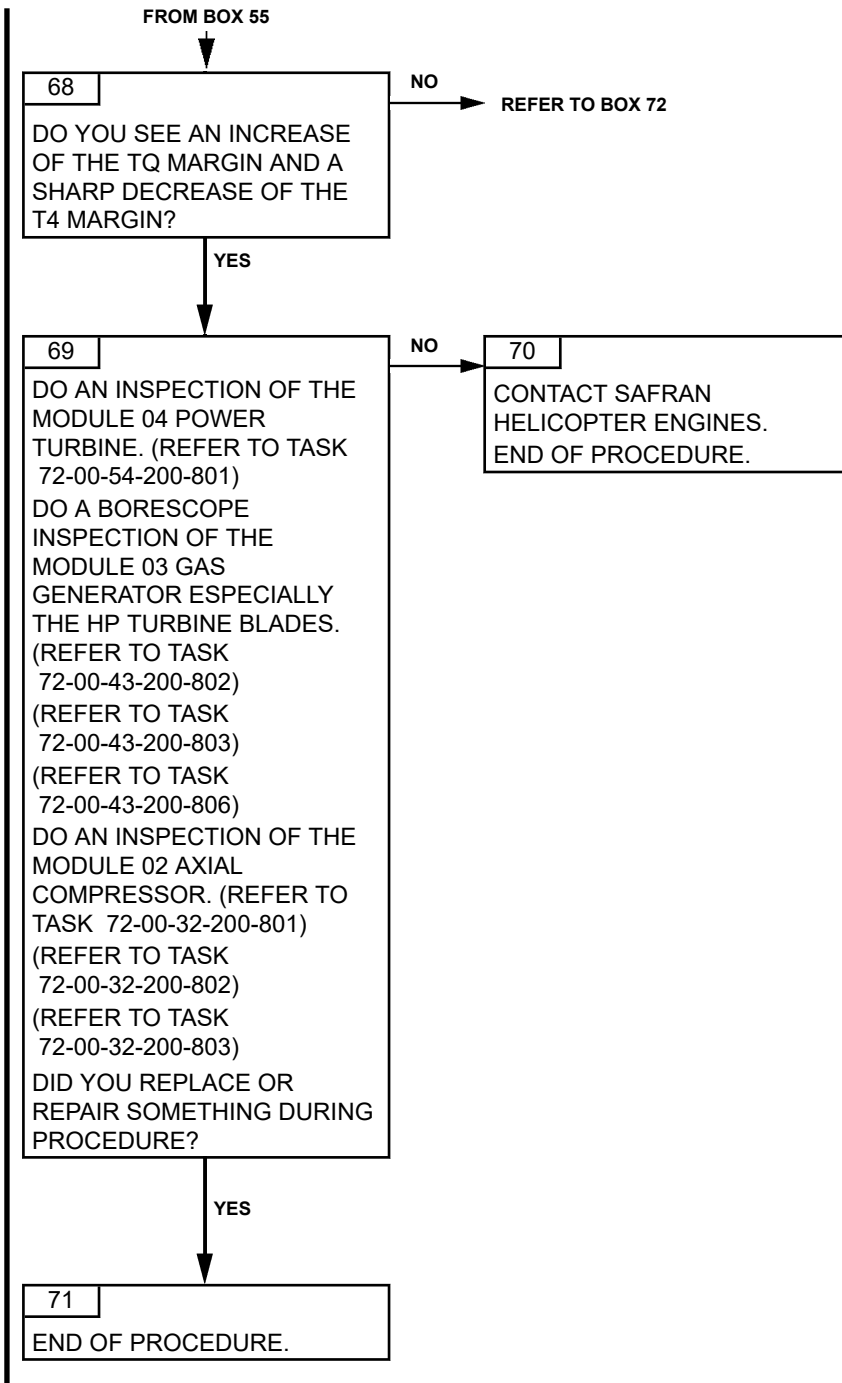

ARRIEL 2 C1

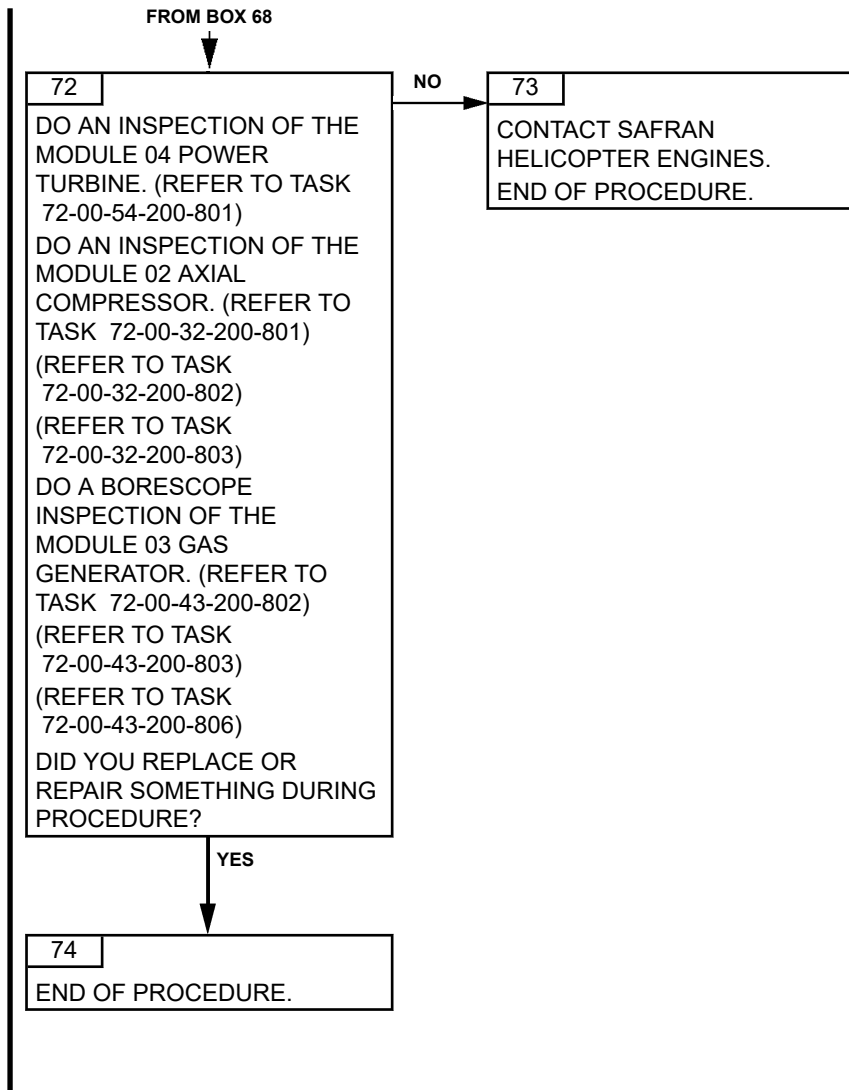

PAGE LEFT BLANK INTENTIONALLY

TASK 71-00-06-816-821-A01

**FUEL ODOR IN THE CABIN
TROUBLESHOOTING**

1. GENERAL

A. FAILURE DETECTION CONDITIONS

- Fuel odor in cabin

B. POSSIBLE CAUSES

- Start electro-valve
- Module 03
- Aircraft

2. PROCEDURE

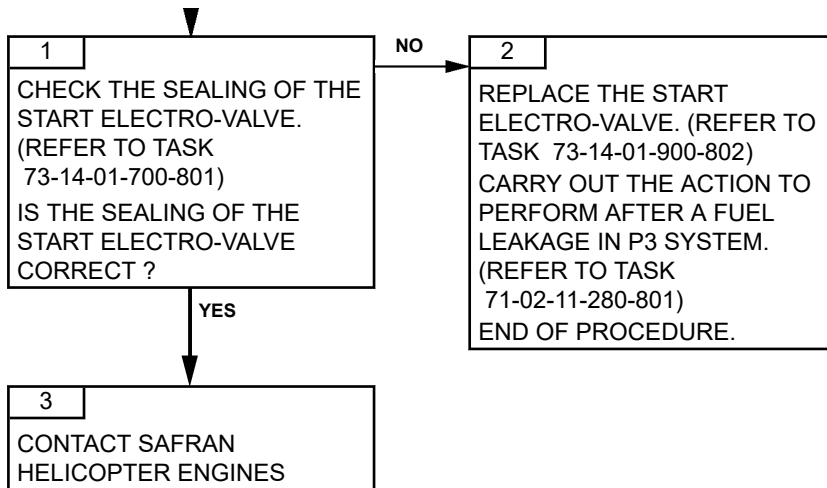

TASK 71-00-06-816-825-A01

**OIL LEAK AT BLEED VALVE OR AIR INTAKE
TROUBLESHOOTING****1. GENERAL****A. REMINDER OF THE NORMAL OPERATING CONDITION**

- In normal operation, while the engine is running there is no oil leak at the bleed valve or the air intake.

B. POSSIBLE CAUSES

- Blockage from the oil vent system (Airframe parts)
- Module 02
- Wrong assembly of the M01 strainers

CAUTION: AN INVERSION OF THE STRAINERS (72-61-00-01-070) AND (72-61-00-01-100) (REFER TO TASK 72-61-00-900-806) COULD LEAD TO AN INCORRECT OIL RETURN TO THE TANK. THAT WILL GENERATE AN OIL OVERFLOW THROUGH BEARING, ALLOWING OIL TO ESCAPE TO THE BLEED VALVE OR THE AIR TAPPINGS DURING NEXT ENGINE RUN.

2. PROCEDURE

NOTE: *Distortion or partial obstruction of the vent line can cause back pressure into the vent system that may increase oil leak from the vent line and also cause oil leak from the bleed valve or the air intake. Pay particular attention to distortion at the tip of the vent line in the exhaust pipe.*

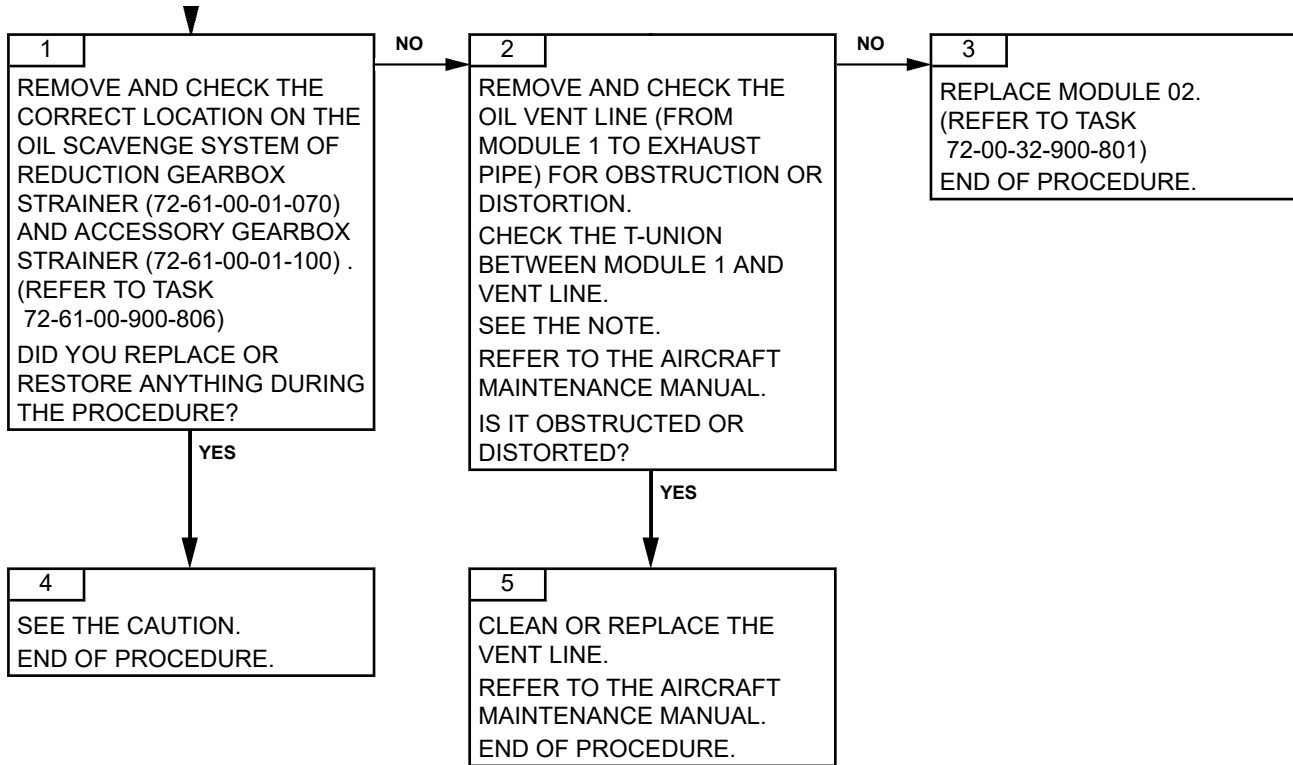

TASK 71-00-06-816-827-A01

OIL LEAKAGE OF THE POWER DRIVE OF THE STARTER TROUBLESHOOTING

1. GENERAL

I A. GENERAL DESCRIPTION

In the event of an oil leakage at the starter power drive, this one must meet the criteria defined on the Task 79-00-00-280-801 (Lubrication system-external leakage/ Special procedure).

B. POSSIBLE CAUSES

- Seal of the Dynastart Adapter.

2. PROCEDURE

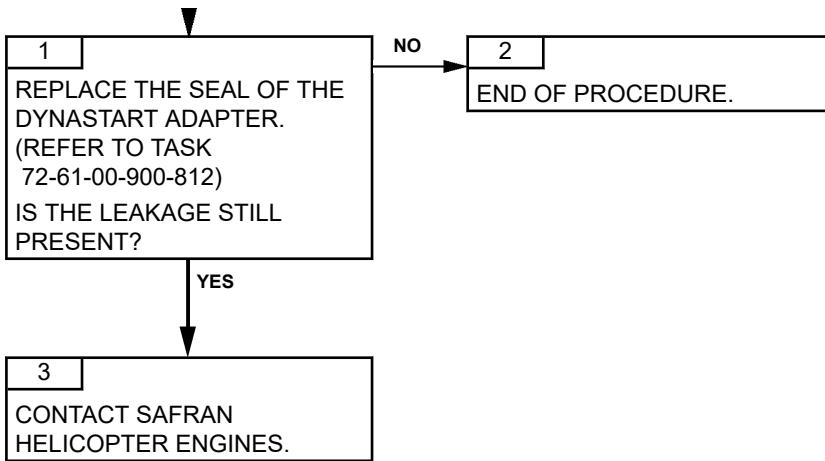

TASK 71-00-06-816-833-A01

**OIL TANK LEVEL SLOWLY DECREASES AFTER
ENGINE SHUTDOWN
TROUBLESHOOTING****1. GENERAL****A. FAILURE DETECTION CONDITIONS**

After an engine is stopped for one day or more, it is possible that the oil level does not return to normal. An internal leak of the oil pump slowly occurs by gravity due to the check valve leakage.

B. POSSIBLE CAUSES

- Oil pump

2. PROCEDURE

1

REPLACE THE OIL PUMP.
(REFER TO TASK
79-24-00-900-801)

NOTE: AFTER AN ENGINE IS STOPPED FOR ONE DAY OR MORE, IT IS POSSIBLE THAT THE OIL LEVEL DOES NOT RETURN TO NORMAL. AN INTERNAL LEAK OF THE OIL PUMP SLOWLY OCCURS BY GRAVITY DUE TO THE CHECK VALVE LEAKAGE.
END OF PROCEDURE.

TASK 71-00-06-817-801-A01

**WATCHDOG TRIP
TROUBLESHOOTING****1. GENERAL****A. VEMD FAILURE MESSAGE**

<i>VEMD MESSAGE</i>
W/DOG. A or W/DOG. B

B. FAILURE EFFECTS

<i>EFFECTS</i>	<i>CAD MESSAGE</i>
<u>If W/DOG. A only</u> Total Failure of Channel A. – If total failure of channel B: stepper motor frozen, EBCAU actuated – Otherwise: automatic reversion to channel B.	FADEC flashing GOV
<u>If W/DOG. B</u> Total Failure of Channel B. – If total failure of channel A: stepper motor frozen, EBCAU actuated – Otherwise: No effect, except impossible reversion to channel B in case of channel A total failure.	FADEC flashing GOV
<u>If W/DOG. A and W/DOG. B</u> Stepper motor frozen, EBCAU actuated.	FADEC

CAUTION: MAKE SURE THAT THE CONCERNED AIRCRAFT SYSTEM IS SERVICEABLE BEFORE YOU SWAP THE ENGINE ELECTRONIC CONTROL UNITS.

CAUTION: WHEN CHECKING THE “FAIL” LINE ON THE VEMD SYSTEM STATUS PAGE, MAKE SURE TO CHECK ALL FAILURES. TO DO SO, PRESS THE SELECT KEY UNTIL A WHITE FRAME SURROUNDS THE “FAIL” LINE. THEN, USE “+/-” KEY TO VIEW ALL FAILURES. PROCEED THE SAME WAY TO CHECK ALL MESSAGES ON THE “MSG” LINE.

CAUTION: THE FAILURE INFORMATION ON THE VEMD SYSTEM STATUS PAGE MAY NO LONGER BE AVAILABLE AFTER BATTERY POWER IS TURNED OFF. THEREFORE, AFTER A FAILURE OCCURRED, IT IS VERY IMPORTANT TO CHECK AND WRITE DOWN ALL INFORMATION FROM THE “FAIL” LINE AND THE “MSG” LINE BEFORE TURNING BATTERY POWER OFF.

C. POSSIBLE CAUSES

- EECU
- Off/Idle/Flight selector function (Aircraft system)

2. PROCEDURE

Effectivity: C1

NOTE: *In normal operation of the selector, at connector P2, at EECU power ON, only the OFF input should be active. The other 2 inputs, IDLE and FLIGHT, should be inactive:*

- *OFF input is active if there is electrical continuity between pins 37 and 38*
- *IDLE input is inactive if there is open circuit between pins 37 and 45*
- *FLIGHT input is inactive if there is open circuit between pins 37 and 39.*

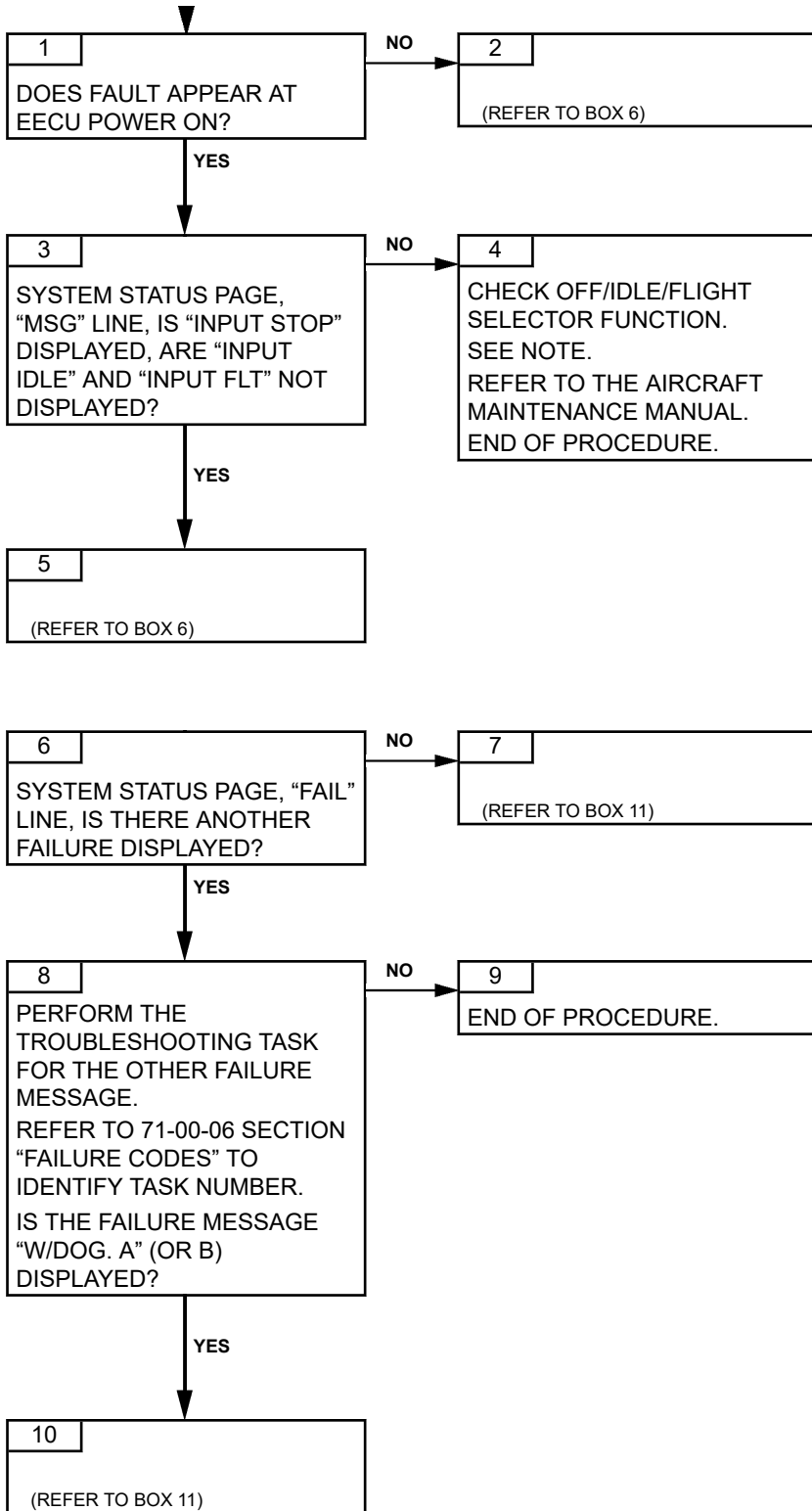

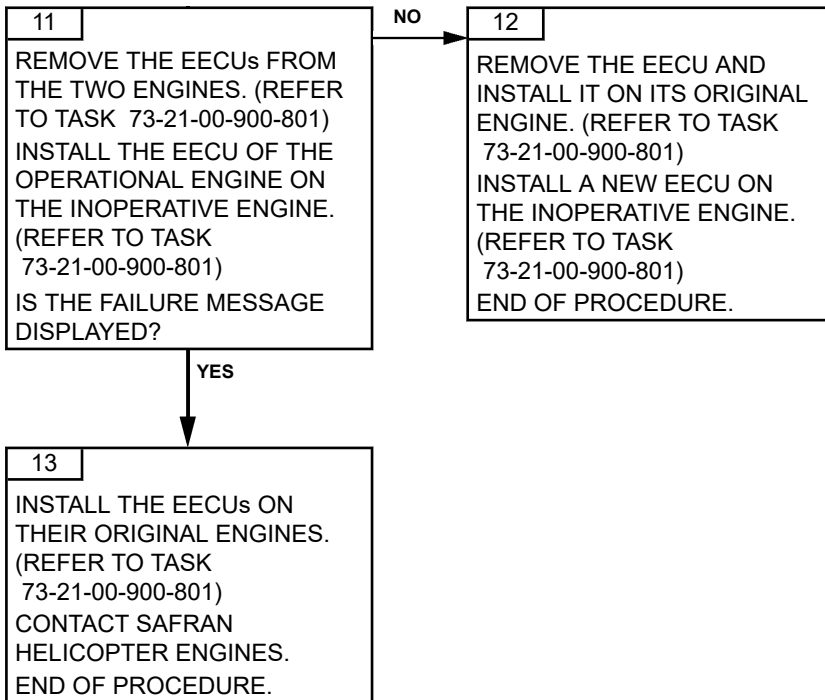

TASK 71-00-06-817-803-A01

N2 TRIM FAILURE, CHANNEL A TROUBLESHOOTING

1. GENERAL

A. VEMD FAILURE MESSAGE

<i>VEMD MESSAGE</i>
TRIM.POS. A

B. FAILURE EFFECTS

<i>EFFECTS</i>	<i>CAD MESSAGE</i>
Use of the back-up value. When the "N2 trim datum" discrete input is activated, a fixed N2 datum is obtained.	GOV

CAUTION: MAKE SURE THAT THE CONCERNED AIRCRAFT SYSTEM IS SERVICEABLE BEFORE YOU SWAP THE ENGINE ELECTRONIC CONTROL UNITS.

CAUTION: WHEN CHECKING THE "FAIL" LINE ON THE VEMD SYSTEM STATUS PAGE, MAKE SURE TO CHECK ALL FAILURES. TO DO SO, PRESS THE SELECT KEY UNTIL A WHITE FRAME SURROUNDS THE "FAIL" LINE. THEN, USE "+/-" KEY TO VIEW ALL FAILURES. PROCEED THE SAME WAY TO CHECK ALL MESSAGES ON THE "MSG" LINE.

CAUTION: THE FAILURE INFORMATION ON THE VEMD SYSTEM STATUS PAGE MAY NO LONGER BE AVAILABLE AFTER BATTERY POWER IS TURNED OFF. THEREFORE, AFTER A FAILURE OCCURRED, IT IS VERY IMPORTANT TO CHECK AND WRITE DOWN ALL INFORMATION FROM THE "FAIL" LINE AND THE "MSG" LINE BEFORE TURNING BATTERY POWER OFF.

C. POSSIBLE CAUSES

- EECU.

2. PROCEDURE

Effectivity: C1

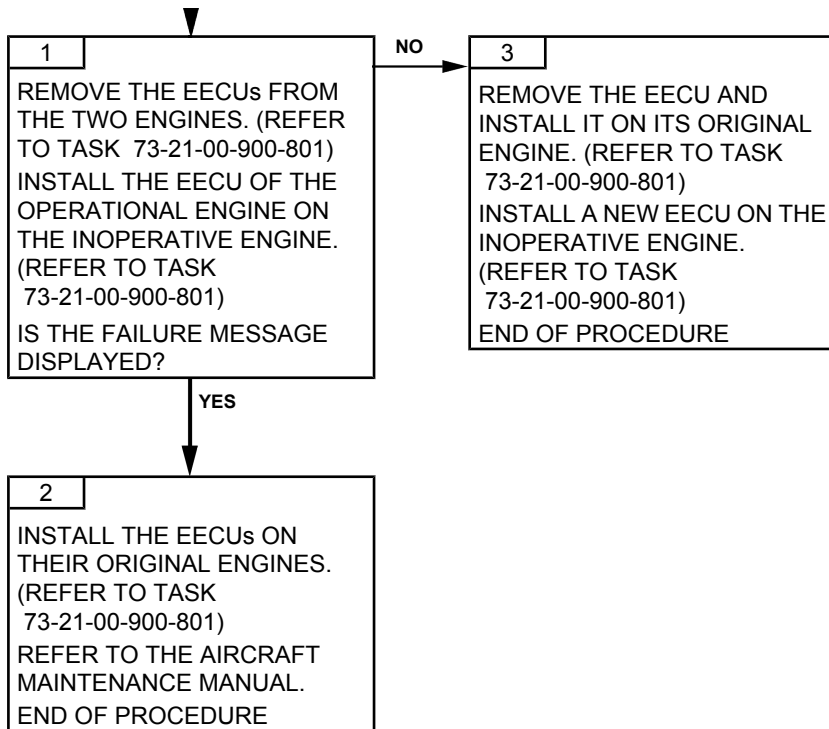

TASK 71-00-06-817-804-A01

N2 TRIM FAILURE, CHANNEL B TROUBLESHOOTING

1. GENERAL

A. VEMD FAILURE MESSAGE

<i>VEMD MESSAGE</i>
TRIM.POS. B

B. FAILURE EFFECTS

<i>EFFECTS</i>	<i>CAD MESSAGE</i>
Use of the back-up value. When the "N2 trim datum" discrete input is activated, a fixed N2 datum is obtained.	GOV

CAUTION: MAKE SURE THAT THE CONCERNED AIRCRAFT SYSTEM IS SERVICEABLE BEFORE YOU SWAP THE ENGINE ELECTRONIC CONTROL UNITS.

CAUTION: WHEN CHECKING THE "FAIL" LINE ON THE VEMD SYSTEM STATUS PAGE, MAKE SURE TO CHECK ALL FAILURES. TO DO SO, PRESS THE SELECT KEY UNTIL A WHITE FRAME SURROUNDS THE "FAIL" LINE. THEN, USE "+/-" KEY TO VIEW ALL FAILURES. PROCEED THE SAME WAY TO CHECK ALL MESSAGES ON THE "MSG" LINE.

CAUTION: THE FAILURE INFORMATION ON THE VEMD SYSTEM STATUS PAGE MAY NO LONGER BE AVAILABLE AFTER BATTERY POWER IS TURNED OFF. THEREFORE, AFTER A FAILURE OCCURRED, IT IS VERY IMPORTANT TO CHECK AND WRITE DOWN ALL INFORMATION FROM THE "FAIL" LINE AND THE "MSG" LINE BEFORE TURNING BATTERY POWER OFF.

C. POSSIBLE CAUSES

- EECU.

2. PROCEDURE

Effectivity: C1

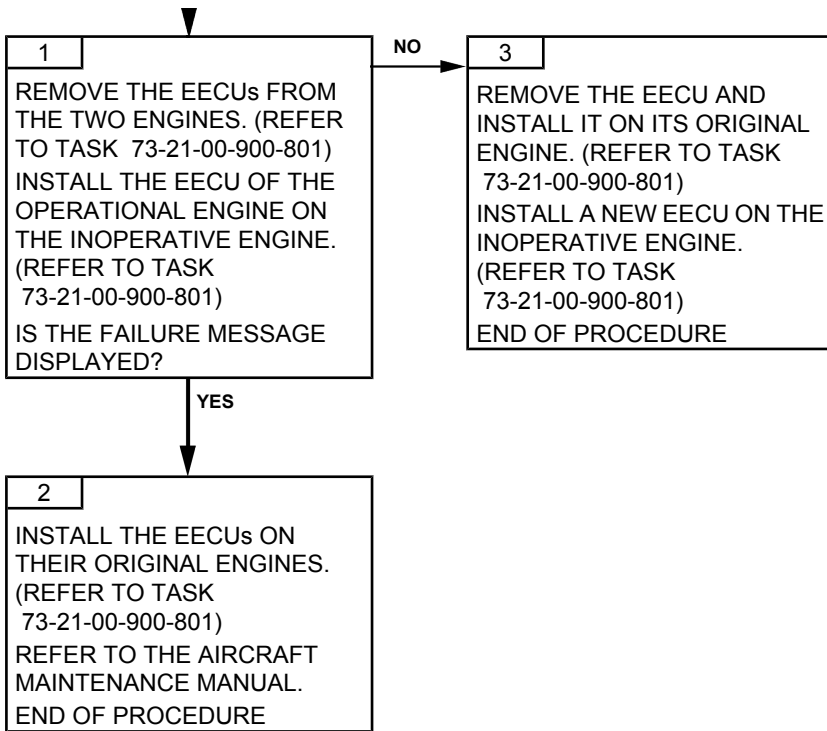

TASK 71-00-06-817-805-A01

TRAINING SELECTOR FAILURE TROUBLESHOOTING

1. GENERAL

A. VEMD FAILURE MESSAGE

VEMD MESSAGE
T/SEL. A or T/SEL. B

B. FAILURE EFFECTS

EFFECTS	CAD MESSAGE
If T/SEL. A only or if T/SEL. A + T/SEL. B – Impossible to use the training mode.	flashing GOV
If T/SEL. B – If channel A in control: no effect – If channel B in control after total failure of channel A: impossible to use the training mode.	flashing GOV flashing GOV

CAUTION: MAKE SURE THAT THE CONCERNED AIRCRAFT SYSTEM IS SERVICEABLE BEFORE YOU SWAP THE ENGINE ELECTRONIC CONTROL UNITS.

CAUTION: WHEN CHECKING THE “FAIL” LINE ON THE VEMD SYSTEM STATUS PAGE, MAKE SURE TO CHECK ALL FAILURES. TO DO SO, PRESS THE SELECT KEY UNTIL A WHITE FRAME SURROUNDS THE “FAIL” LINE. THEN, USE “+/-” KEY TO VIEW ALL FAILURES. PROCEED THE SAME WAY TO CHECK ALL MESSAGES ON THE “MSG” LINE.

CAUTION: THE FAILURE INFORMATION ON THE VEMD SYSTEM STATUS PAGE MAY NO LONGER BE AVAILABLE AFTER BATTERY POWER IS TURNED OFF. THEREFORE, AFTER A FAILURE OCCURRED, IT IS VERY IMPORTANT TO CHECK AND WRITE DOWN ALL INFORMATION FROM THE “FAIL” LINE AND THE “MSG” LINE BEFORE TURNING BATTERY POWER OFF.

C. POSSIBLE CAUSES

- EECU
- Training Selector function (Aircraft system)

2. PROCEDURE

NOTE: *In normal operation of the selector, at connector P2 engine 1:*

- *In IDLE 1 position, pins 37 and 44 are connected, pins 37 and 43 are disconnected*
- *In IDLE 2 position, pins 37 and 43 are connected, pins 37 and 44 are disconnected*
- *In OFF position, pins 37, 43 and 44 are disconnected.*

Effectivity: C1

At connector P2 engine 2:

- *In IDLE 1 position, pins 37 and 43 are connected, pins 37 and 44 are disconnected*
- *In IDLE 2 position, pins 37 and 44 are connected, pins 37 and 43 are disconnected*
- *In OFF position, pins 37, 43 and 44 are disconnected.*

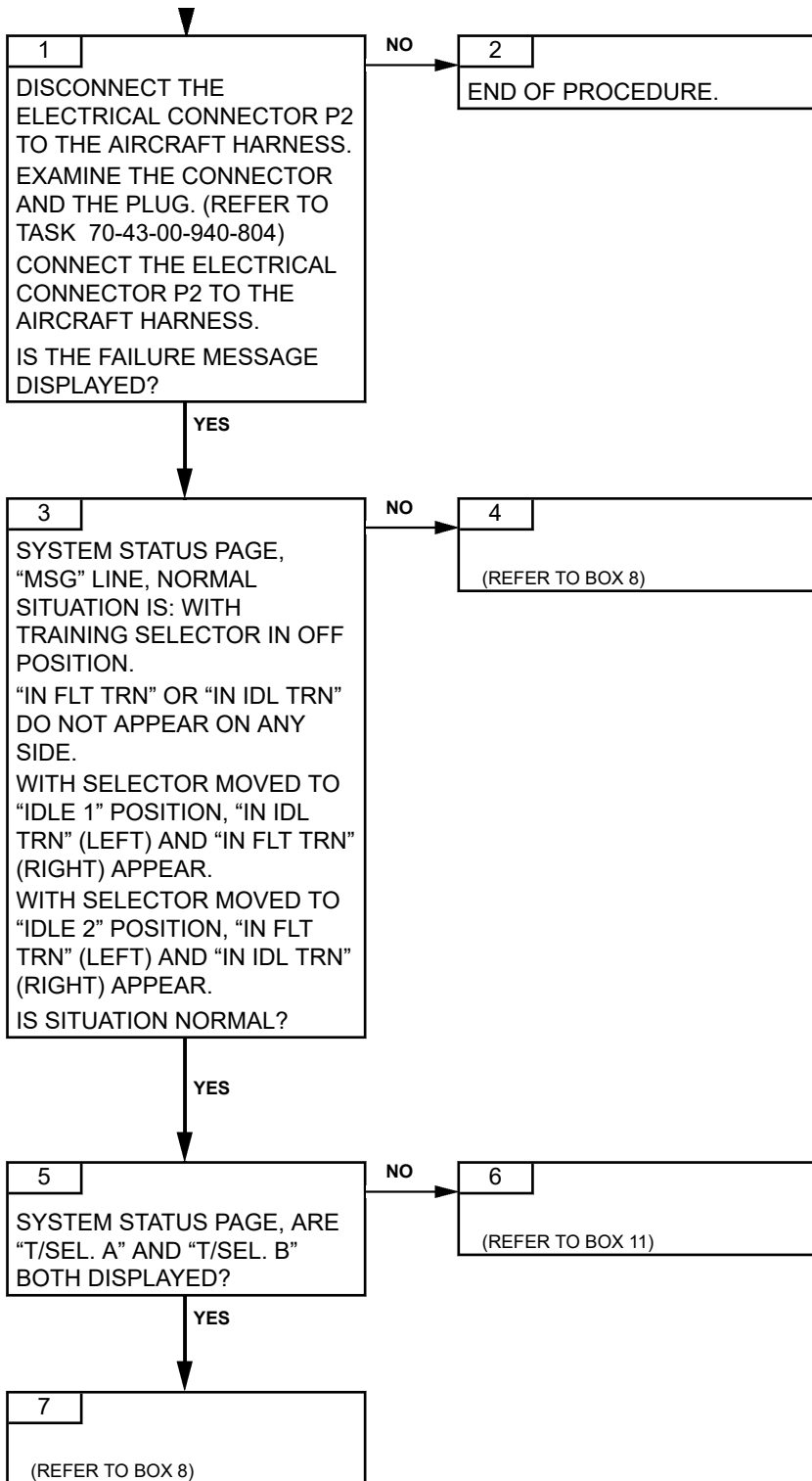

Effectivity: C1

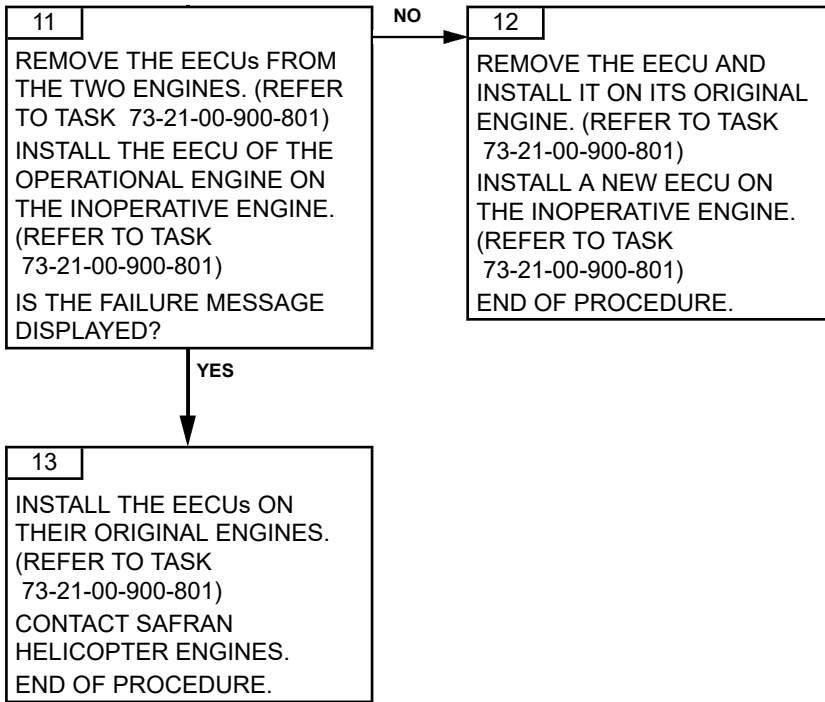
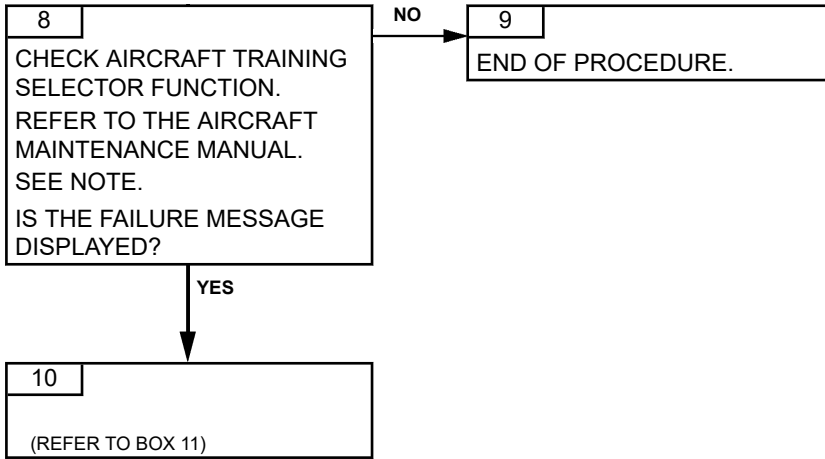

TASK 71-00-06-817-808-A01

**OFF/IDLE/FLIGHT SELECTOR FAILURE
TROUBLESHOOTING**

1. GENERAL

A. VEMD FAILURE MESSAGE

<i>VEMD MESSAGE</i>
SELECT. A or SELECT. B

B. FAILURE EFFECTS

<i>EFFECTS</i>	<i>CAD MESSAGE</i>
<p><u>If SELECT. A only</u></p> <ul style="list-style-type: none"> – At power up or when engine is stopped: total failure of the channel. Reversion to channel B. – Engine running in flight state: the state is frozen in flight mode. – Engine running in idle or stop: the state is frozen in mode (idle or stop) at time of failure. 	<p>flashing GOV</p> <p>flashing GOV GOV</p>
<p><u>If SELECT. B only</u></p> <ul style="list-style-type: none"> – If no total failure of channel A: channel A remains in control, no effect on system. – If total failure of channel A: same effect as if SELECT. A and SELECT. B at same time (see below). 	<p>flashing GOV</p>
<p><u>If SELECT. A and SELECT. B</u></p> <ul style="list-style-type: none"> – At power up or when engine is stopped: total failure of both channels. Start impossible. – Engine running in flight state: the state is frozen in flight mode. – Engine running in idle or stop: the state is frozen in mode (idle or stop) at time of failure. 	<p>FADEC</p> <p>flashing GOV GOV</p>

CAUTION: MAKE SURE THAT THE CONCERNED AIRCRAFT SYSTEM IS SERVICEABLE BEFORE YOU SWAP THE ENGINE ELECTRONIC CONTROL UNITS.

CAUTION: WHEN CHECKING THE “FAIL” LINE ON THE VEMD SYSTEM STATUS PAGE, MAKE SURE TO CHECK ALL FAILURES. TO DO SO, PRESS THE SELECT KEY UNTIL A WHITE FRAME SURROUNDS THE “FAIL” LINE. THEN, USE “+/-” KEY TO VIEW ALL FAILURES. PROCEED THE SAME WAY TO CHECK ALL MESSAGES ON THE “MSG” LINE.

CAUTION: THE FAILURE INFORMATION ON THE VEMD SYSTEM STATUS PAGE MAY NO LONGER BE AVAILABLE AFTER BATTERY POWER IS TURNED OFF. THEREFORE, AFTER A FAILURE OCCURRED, IT IS VERY IMPORTANT TO CHECK AND WRITE DOWN ALL INFORMATION FROM THE “FAIL” LINE AND THE “MSG” LINE BEFORE TURNING BATTERY POWER OFF.

Effectivity: C1

C. POSSIBLE CAUSES

- EECU
- Off/Idle/Flight selector function (Aircraft system)

2. PROCEDURE

NOTE: In normal operation of the selector, at connector P2, one and only one out of the three inputs (OFF, IDLE or FLIGHT) should be active. The active input corresponds to the selector position:

- OFF input is active if there is electrical continuity between pins 37 and 38
- IDLE input is active if there is electrical continuity between pins 37 and 45
- FLIGHT input is active if there is continuity between pins 37 and 39.

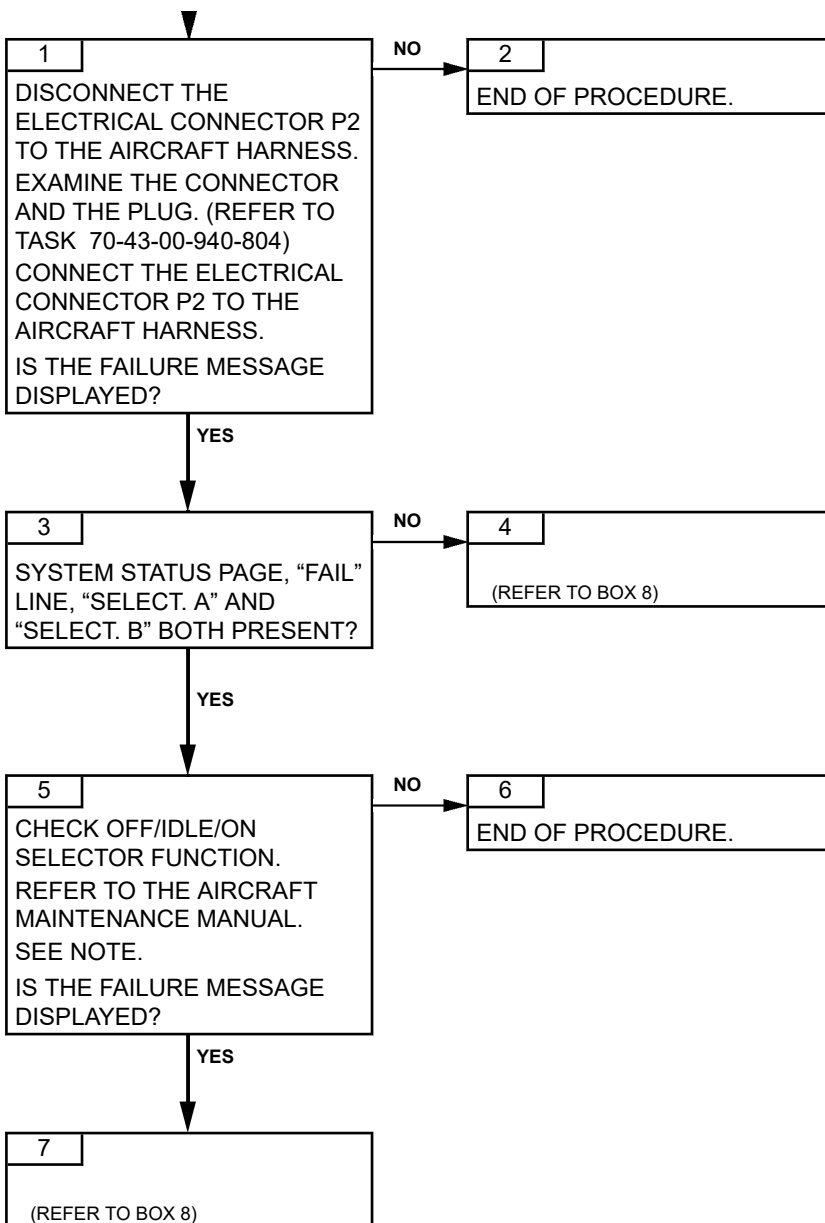

ARRIEL 2 C1

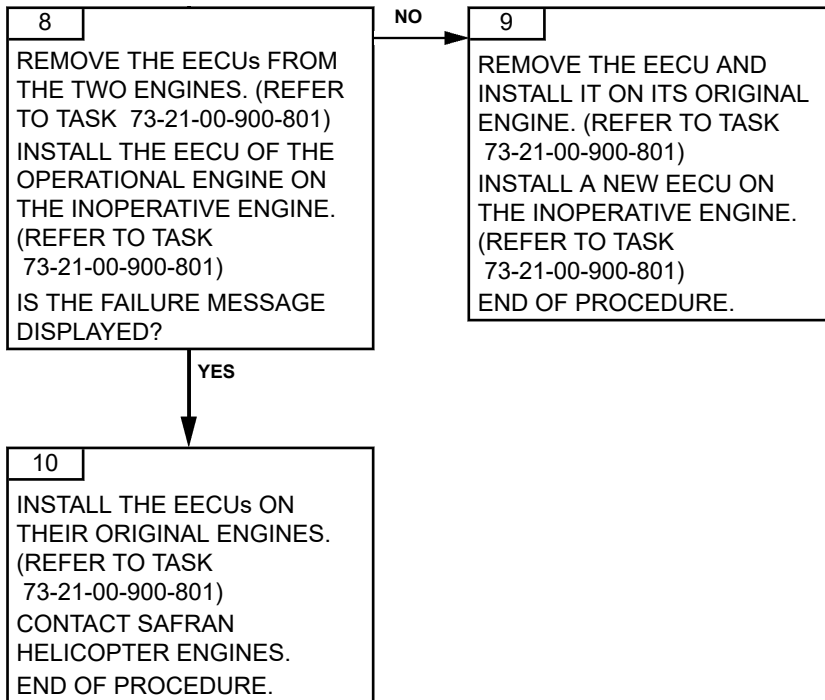

PAGE LEFT BLANK INTENTIONALLY

TASK 71-00-06-817-810-A01

**T1 INCONSISTENCY
TROUBLESHOOTING****1. GENERAL****A. VEMD FAILURE MESSAGE**

<i>VEMD MESSAGE</i>
TO DISC. A

B. FAILURE EFFECTS

<i>EFFECTS</i>	<i>CAD MESSAGE</i>
No effect, except indication of maintenance need. This fault can be detected only when both engines are stopped.	flashing GOV

NOTE: *This failure will be declared if there is a difference greater than 15°C between the T1 values received by each EECU. This test is done only when both engines are stopped.*

CAUTION: MAKE SURE THAT THE CONCERNED AIRCRAFT SYSTEM IS SERVICEABLE BEFORE YOU SWAP THE ENGINE ELECTRONIC CONTROL UNITS.

CAUTION: WHEN CHECKING THE “FAIL” LINE ON THE VEMD SYSTEM STATUS PAGE, MAKE SURE TO CHECK ALL FAILURES. TO DO SO, PRESS THE SELECT KEY UNTIL A WHITE FRAME SURROUNDS THE “FAIL” LINE. THEN, USE “+/-” KEY TO VIEW ALL FAILURES. PROCEED THE SAME WAY TO CHECK ALL MESSAGES ON THE “MSG” LINE.

CAUTION: THE FAILURE INFORMATION ON THE VEMD SYSTEM STATUS PAGE MAY NO LONGER BE AVAILABLE AFTER BATTERY POWER IS TURNED OFF. THEREFORE, AFTER A FAILURE OCCURRED, IT IS VERY IMPORTANT TO CHECK AND WRITE DOWN ALL INFORMATION FROM THE “FAIL” LINE AND THE “MSG” LINE BEFORE TURNING BATTERY POWER OFF.

C. POSSIBLE CAUSES

- EECU
- Control harness
- T1 Sensing function (Aircraft system)

2. PROCEDURE

NOTE: *Normal T1 sensing interface at plug J101 (interfacing with connector P101):*

- *Between pins 3 and 4: short circuit*
- *Between pins 1 and 2: short circuit*
- *Between Pins 1/2 and 3/4: T0 sensor resistance.*

Effectivity: C1

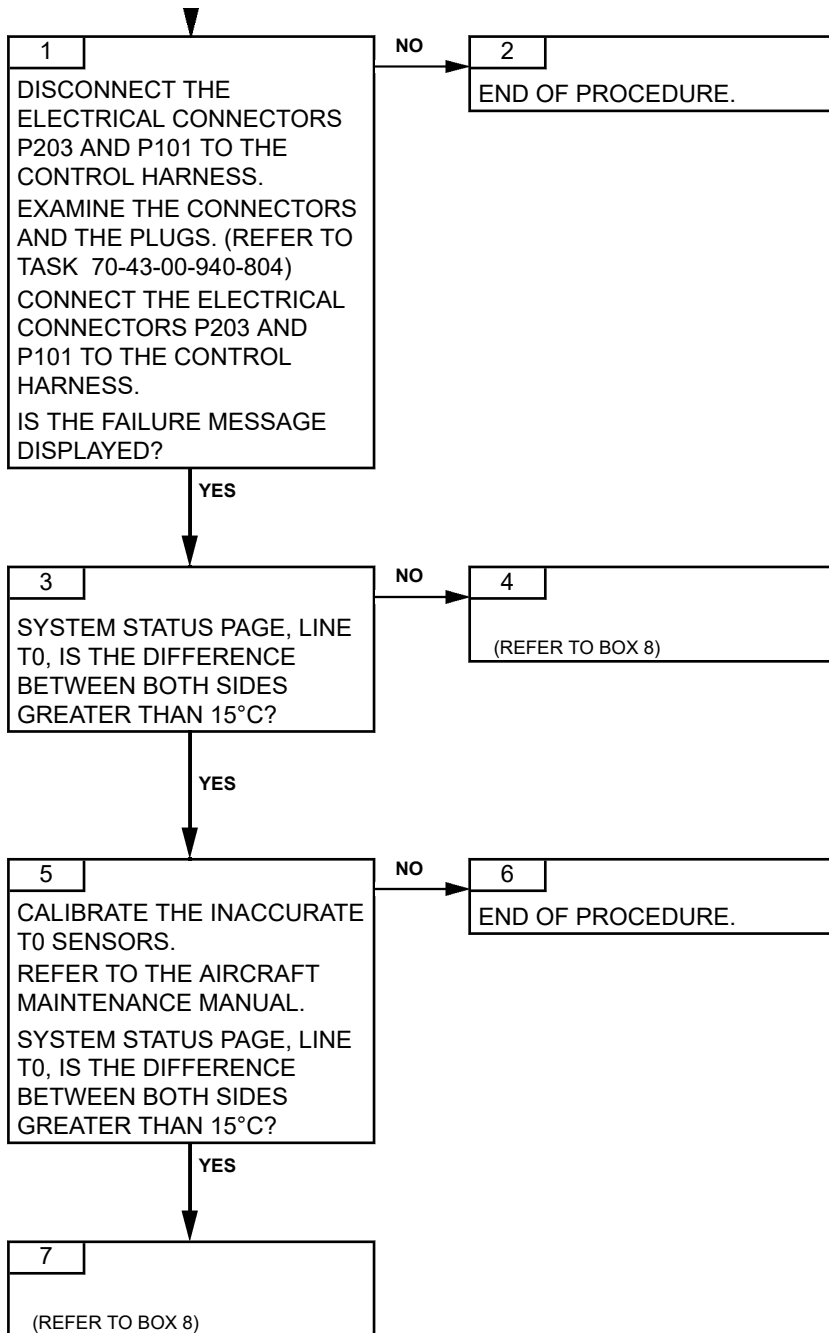

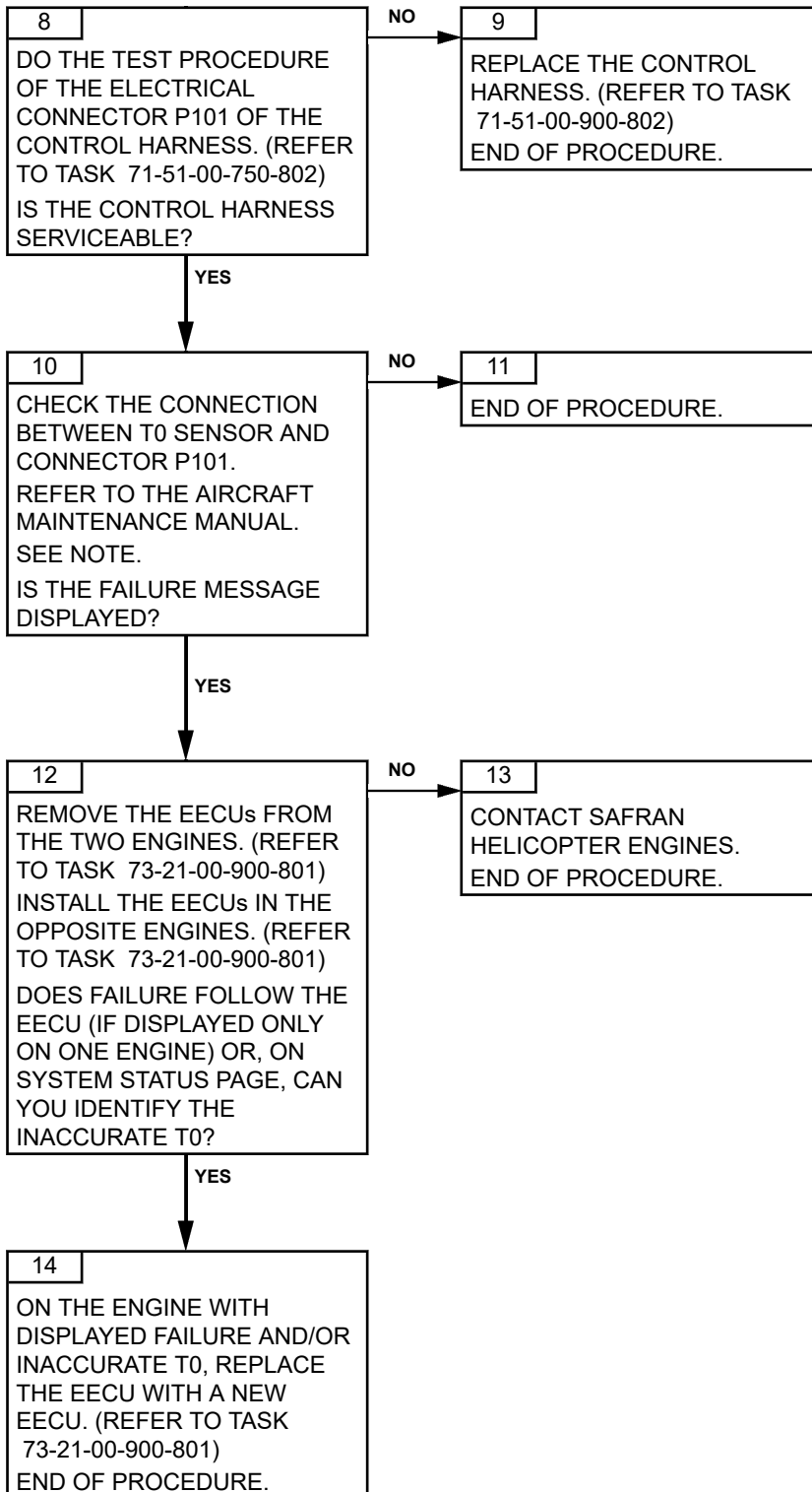

PAGE LEFT BLANK INTENTIONALLY

TASK 71-00-06-817-823-A01

**COLLECTIVE PITCH FAILURE
TROUBLESHOOTING****1. GENERAL****A. VEMD FAILURE MESSAGE**

VEMD MESSAGE
PITCH. A or PITCH. B

B. FAILURE EFFECTS

EFFECTS	CAD MESSAGE
<u>If PITCH. A only or if PITCH. A + PITCH. B</u>	
– If XPC valid value available on cross-talk ARINC: use of this value as back-up. No effect	flashing GOV
– If XPC valid value not available in reception of the balancing ARINC: degraded transients. Use of a fixed back-up value.	GOV
<u>If PITCH. B only</u>	
– If channel A in control: no effect	flashing GOV
– If channel B in control following channel A total failure: degraded transients. Use of a fixed back-up value.	GOV

CAUTION: MAKE SURE THAT THE CONCERNED AIRCRAFT SYSTEM IS SERVICEABLE BEFORE YOU SWAP THE ENGINE ELECTRONIC CONTROL UNITS.

CAUTION: WHEN CHECKING THE “FAIL” LINE ON THE VEMD SYSTEM STATUS PAGE, MAKE SURE TO CHECK ALL FAILURES. TO DO SO, PRESS THE SELECT KEY UNTIL A WHITE FRAME SURROUNDS THE “FAIL” LINE. THEN, USE “+/-” KEY TO VIEW ALL FAILURES. PROCEED THE SAME WAY TO CHECK ALL MESSAGES ON THE “MSG” LINE.

CAUTION: THE FAILURE INFORMATION ON THE VEMD SYSTEM STATUS PAGE MAY NO LONGER BE AVAILABLE AFTER BATTERY POWER IS TURNED OFF. THEREFORE, AFTER A FAILURE OCCURRED, IT IS VERY IMPORTANT TO CHECK AND WRITE DOWN ALL INFORMATION FROM THE “FAIL” LINE AND THE “MSG” LINE BEFORE TURNING BATTERY POWER OFF.

C. POSSIBLE CAUSES

- EECU
- Collective pitch sensing function (Potentiometer, wiring, connections - Aircraft system)

2. PROCEDURE

NOTE: *At the EECU interface, connector P4, with normal connection to the collective pitch potentiometer, there should be:*

- *Between pins 48 and 55: short circuit*

Effectivity: C1

- Between pins 47 and 56: resistance 5 kΩ +/- 10%
- Between pins 47 and 49: measurement resistance (< 5 kΩ).

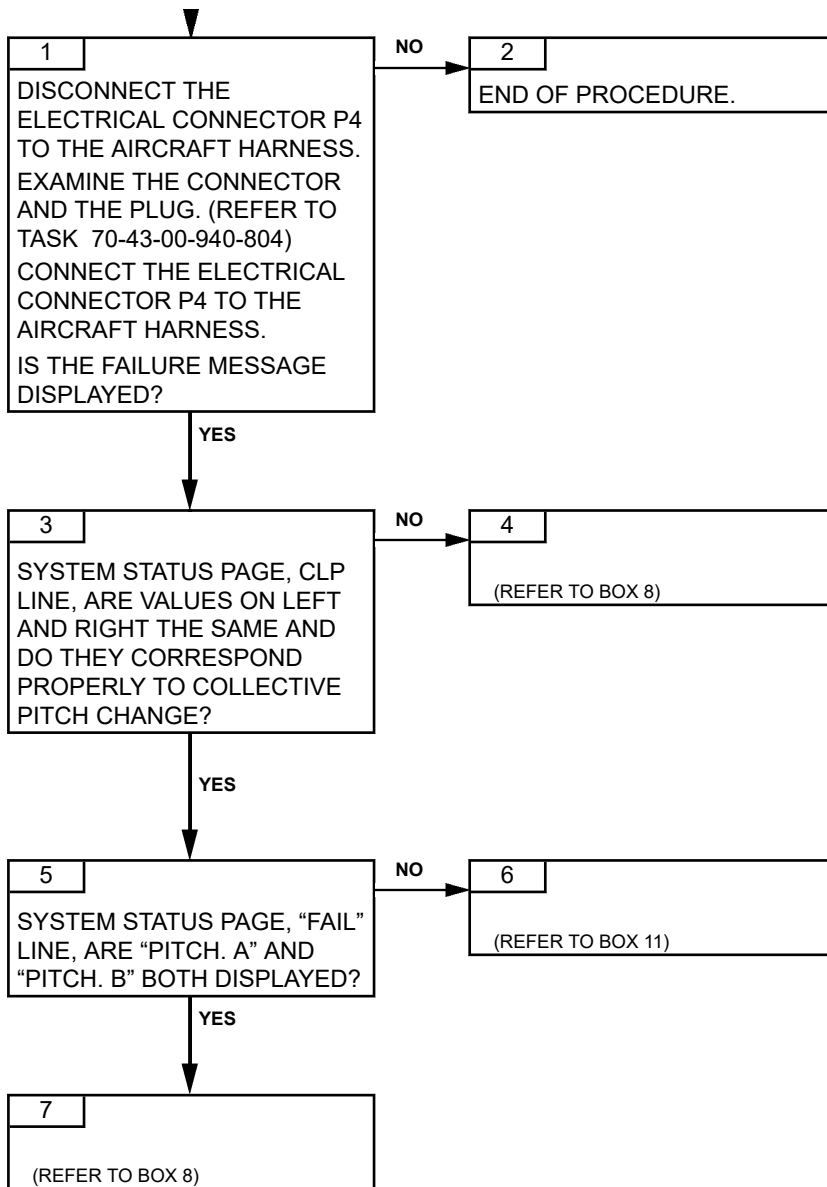

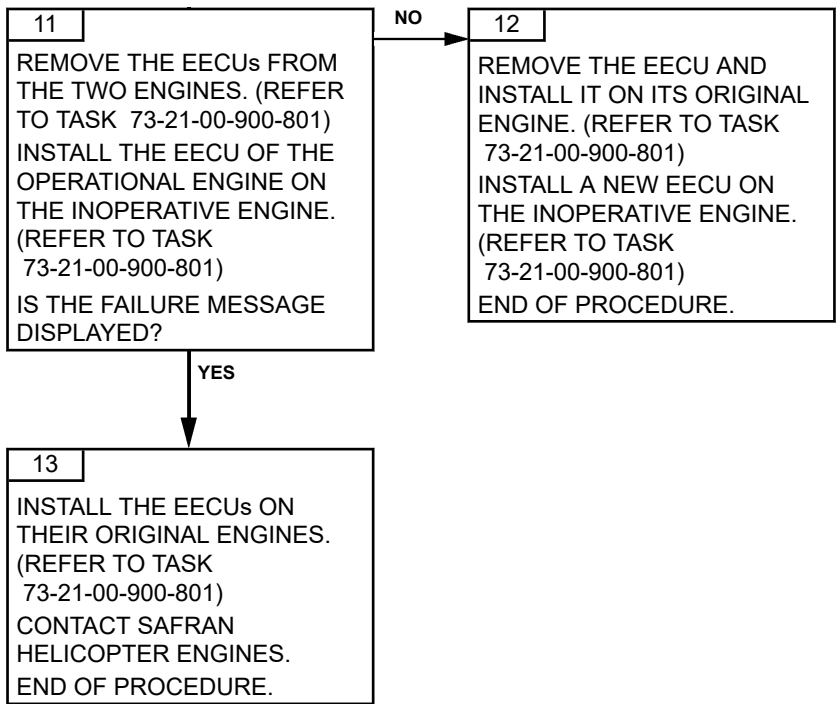
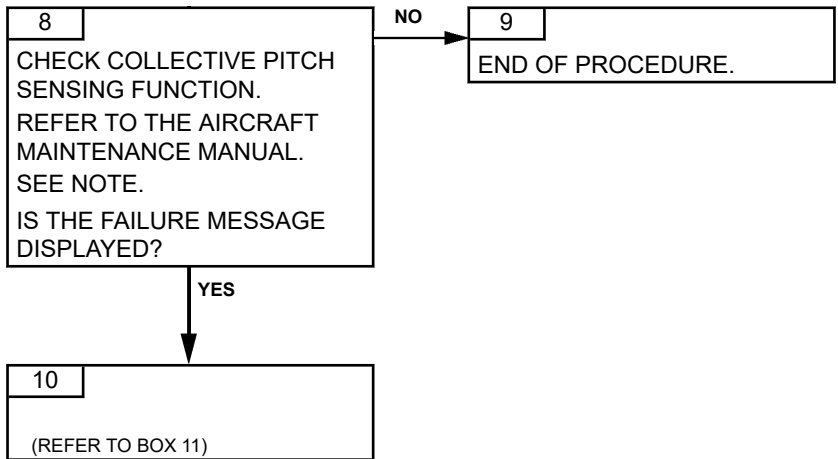

PAGE LEFT BLANK INTENTIONALLY

TASK 71-00-06-817-825-A01

**TOT (T4) FAIL
TROUBLESHOOTING**

1. GENERAL

A. VEMD FAILURE MESSAGE

<i>VEMD MESSAGE</i>
TOT. A or TOT. B

B. FAILURE EFFECTS

<i>EFFECTS</i>	<i>CAD MESSAGE</i>
<u>If TOT. A only or if TOT. A + TOT. B</u>	
<ul style="list-style-type: none"> - If no T4.5 conformation failure and helicopter T4.5 available on ARINC link: use of these values as back-up, after having "de-conformed" the helicopter T4.5. No effect - Otherwise: <ul style="list-style-type: none"> • Before end of start: start interrupted • After end of start: backup T4.5 value. No effect. 	flashing GOV GOV flashing GOV
<u>If TOT. B only</u>	
<ul style="list-style-type: none"> - If channel A in control: no effect - If channel B in control after total failure of channel A: <ul style="list-style-type: none"> • Before end of start: start interrupted • After end of start: backup T4.5 value. No effect. 	flashing GOV GOV flashing GOV

CAUTION: MAKE SURE THAT THE CONCERNED AIRCRAFT SYSTEM IS SERVICEABLE BEFORE YOU SWAP THE ENGINE ELECTRONIC CONTROL UNITS.

CAUTION: WHEN CHECKING THE "FAIL" LINE ON THE VEMD SYSTEM STATUS PAGE, MAKE SURE TO CHECK ALL FAILURES. TO DO SO, PRESS THE SELECT KEY UNTIL A WHITE FRAME SURROUNDS THE "FAIL" LINE. THEN, USE "+/-" KEY TO VIEW ALL FAILURES. PROCEED THE SAME WAY TO CHECK ALL MESSAGES ON THE "MSG" LINE.

CAUTION: THE FAILURE INFORMATION ON THE VEMD SYSTEM STATUS PAGE MAY NO LONGER BE AVAILABLE AFTER BATTERY POWER IS TURNED OFF. THEREFORE, AFTER A FAILURE OCCURRED, IT IS VERY IMPORTANT TO CHECK AND WRITE DOWN ALL INFORMATION FROM THE "FAIL" LINE AND THE "MSG" LINE BEFORE TURNING BATTERY POWER OFF.

C. POSSIBLE CAUSES

- Junction and T4.5 conformation box
- Pyrometric harness
- EECU
- Control harness

Effectivity: C1

2. PROCEDURE

NOTE: *This failure may happen only when the pyrometric probes are hot. In this case, it will normally not be present at EECU power on. However, if the check is done right after an engine run, when the probes are still hot, the failure may occur at EECU power on and you will be able to troubleshoot the faulty pyrometric harness on ground, as per this fault tree.*

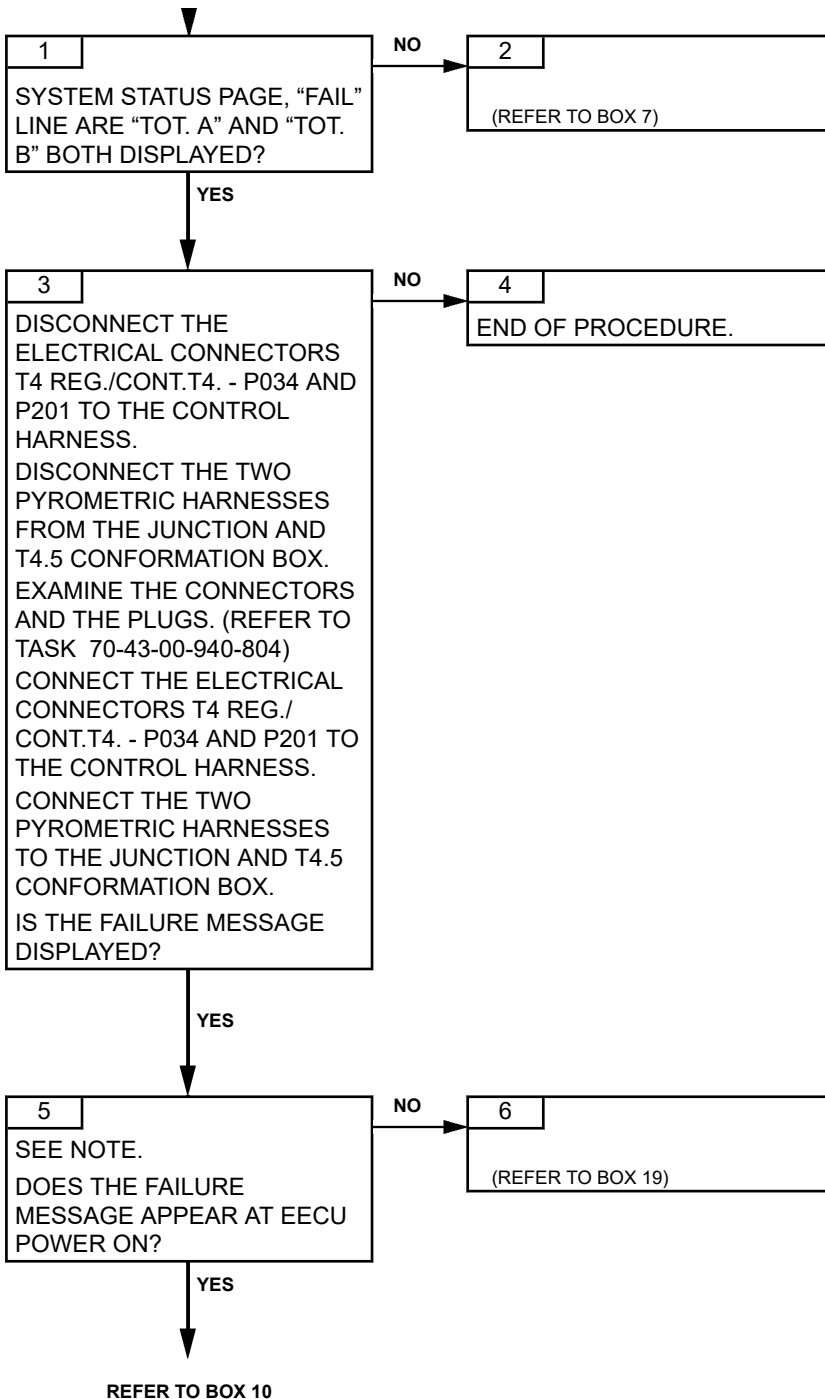

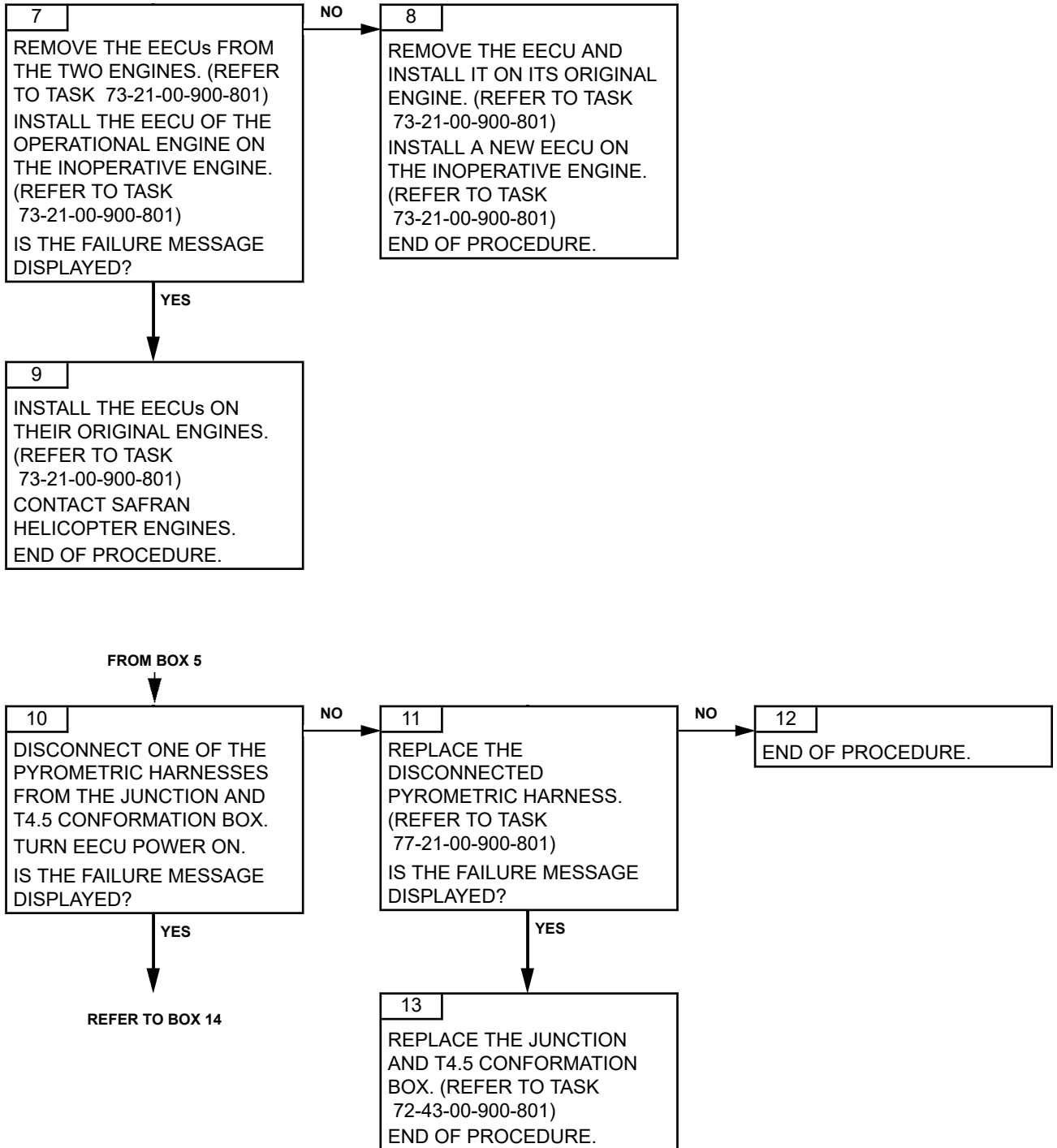

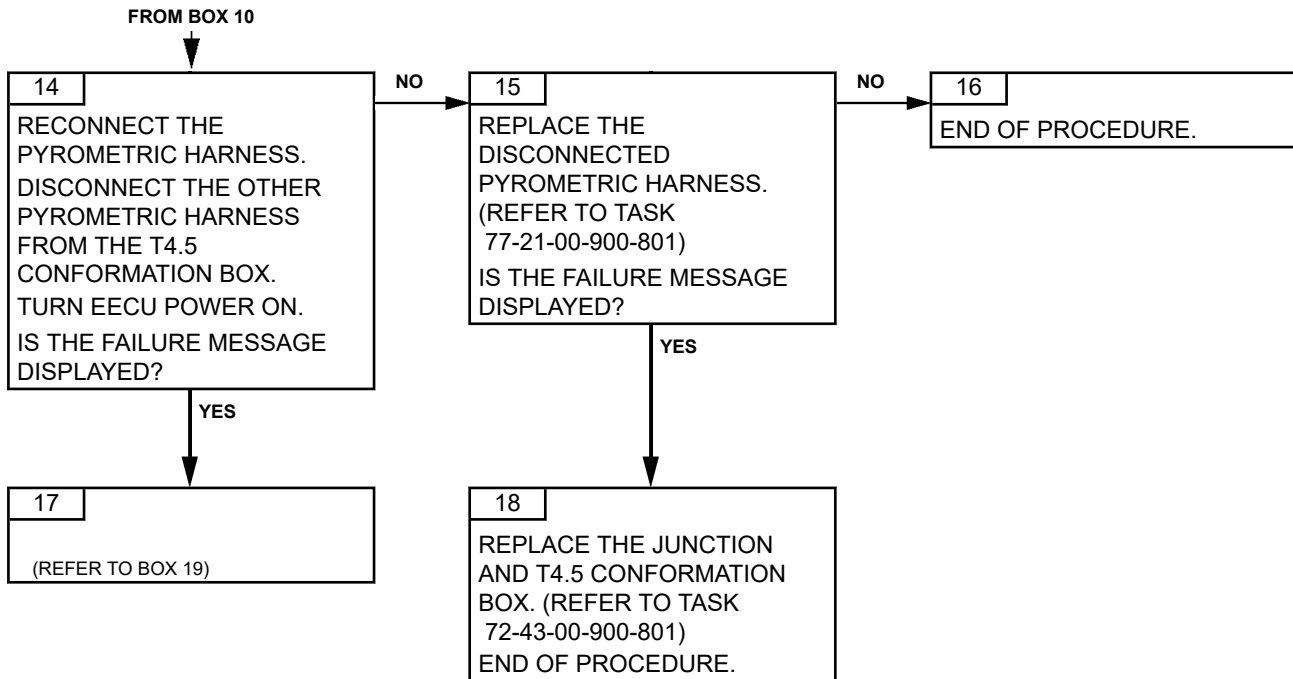

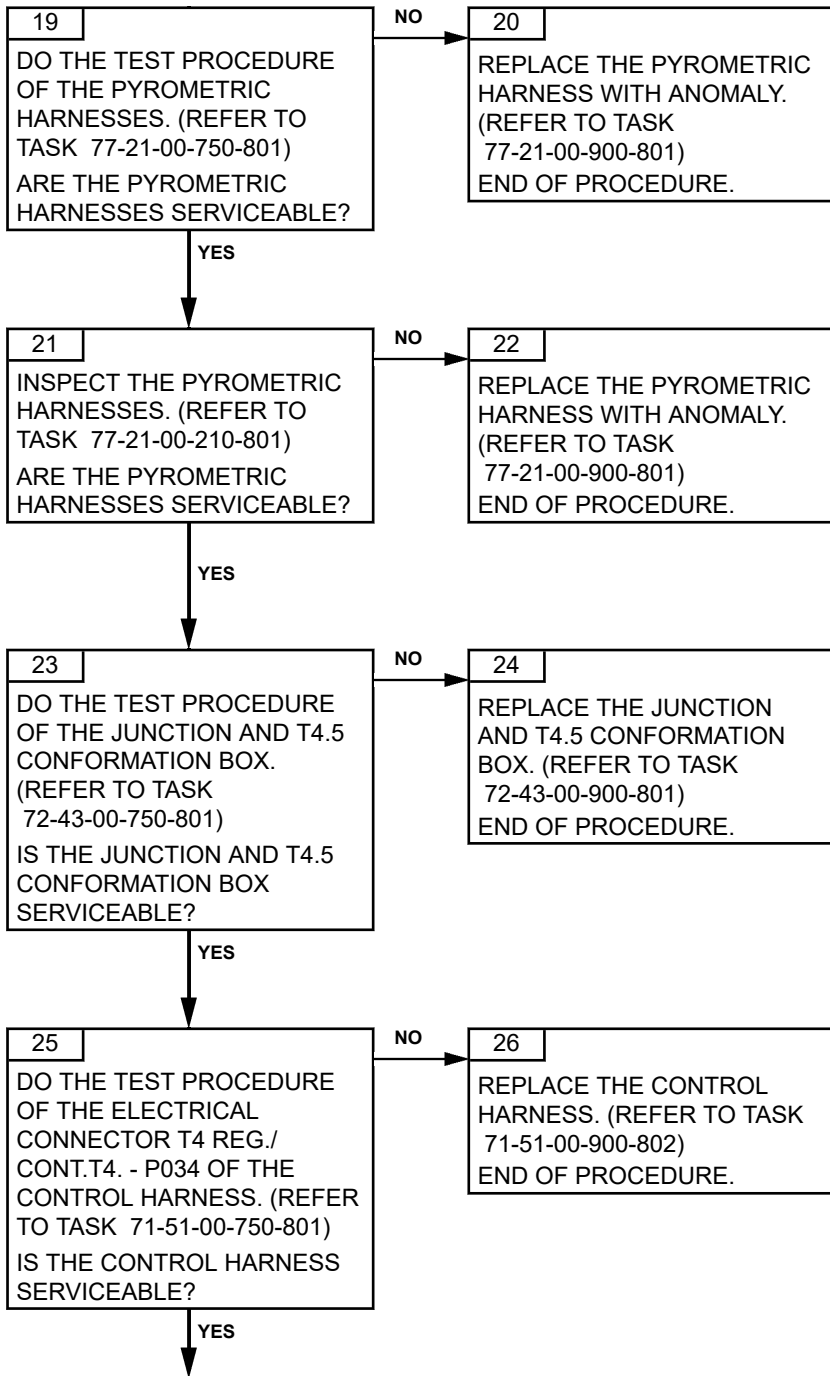

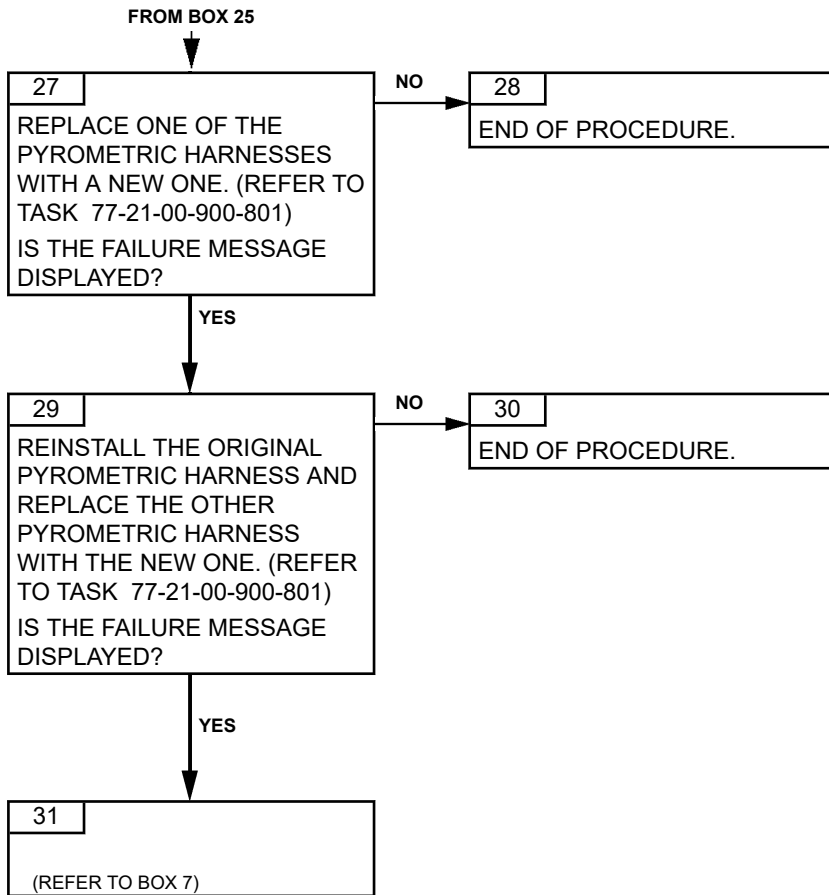

TASK 71-00-06-817-828-A01

**T0 FAIL
TROUBLESHOOTING****1. GENERAL****A. VEMD FAILURE MESSAGE**

VEMD MESSAGE
T1. A or T1. B

B. FAILURE EFFECTS

EFFECTS	CAD MESSAGE
<u>If T1. A only or if T1. A + d T1. B</u>	
– If T1 valid value available from cross-talk ARINC: use of this value as backup, no effect	flashing GOV
– If T1 valid value not available from cross-talk ARINC: transients are degraded but the engine remains protected against surge and flame-out.	GOV
<u>If T1. B only</u>	
– If channel A in control: no effect	flashing GOV
– If channel B in control following a channel A total control failure: transients are degraded but the engine remains protected against surge and flame-out.	GOV

CAUTION: MAKE SURE THAT THE CONCERNED AIRCRAFT SYSTEM IS SERVICEABLE BEFORE YOU SWAP THE ENGINE ELECTRONIC CONTROL UNITS.

CAUTION: WHEN CHECKING THE “FAIL” LINE ON THE VEMD SYSTEM STATUS PAGE, MAKE SURE TO CHECK ALL FAILURES. TO DO SO, PRESS THE SELECT KEY UNTIL A WHITE FRAME SURROUNDS THE “FAIL” LINE. THEN, USE “+/-” KEY TO VIEW ALL FAILURES. PROCEED THE SAME WAY TO CHECK ALL MESSAGES ON THE “MSG” LINE.

CAUTION: THE FAILURE INFORMATION ON THE VEMD SYSTEM STATUS PAGE MAY NO LONGER BE AVAILABLE AFTER BATTERY POWER IS TURNED OFF. THEREFORE, AFTER A FAILURE OCCURRED, IT IS VERY IMPORTANT TO CHECK AND WRITE DOWN ALL INFORMATION FROM THE “FAIL” LINE AND THE “MSG” LINE BEFORE TURNING BATTERY POWER OFF.

C. POSSIBLE CAUSES

- EECU
- Control harness
- T1 sensing function (Aircraft system)

2. PROCEDURE

NOTE: Normal T1 sensing interface at plug J101 (interfacing with connector P101):

- Between pins 3 and 4: short circuit

Effectivity: C1

- *Between pins 1 and 2: short circuit*
- *Between Pins 1/2 and 3/4: T0 sensor resistance.*

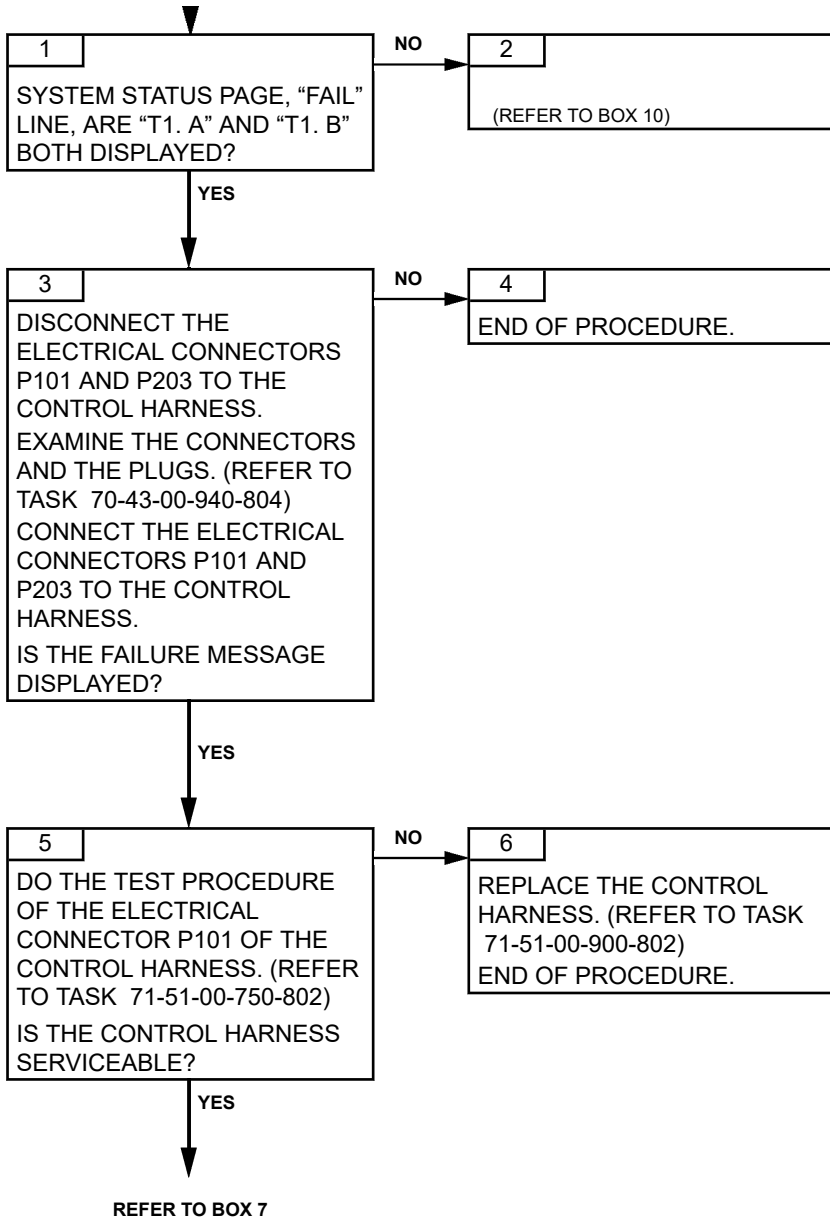

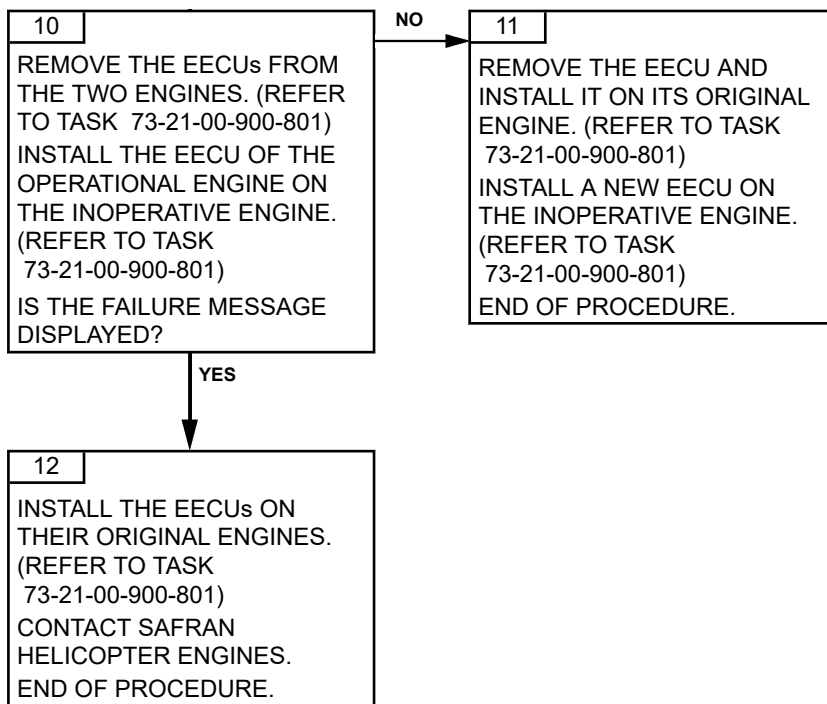
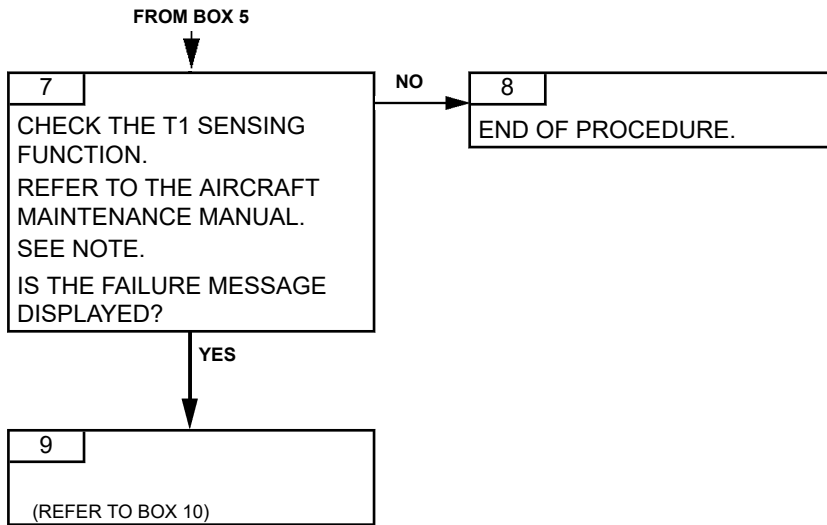

TASK 71-00-06-817-833-A01

**P3 FAILURE
TROUBLESHOOTING****1. GENERAL****A. VEMD FAILURE MESSAGE**

<i>VEMD MESSAGE</i>
P3. A or P3. B

B. FAILURE EFFECTS

<i>EFFECTS</i>	<i>CAD MESSAGE</i>
<p>If P3. A only or if P3. A + P3. B</p> <ul style="list-style-type: none"> – Transients are degraded but the engine remains protected against surge and flame-out. In case of accidental surge, risk of not managing it. <p>If P3. B only</p> <ul style="list-style-type: none"> – If channel A in control: no effect – If channel B in control following a channel A total control failure: transients are degraded but the engine remains protected against surge and flame-out. In case of accidental surge, risk of not managing it. 	<p>GOV</p> <p>flashing GOV GOV</p>

CAUTION: MAKE SURE THAT THE CONCERNED AIRCRAFT SYSTEM IS SERVICEABLE BEFORE YOU SWAP THE ENGINE ELECTRONIC CONTROL UNITS.

CAUTION: WHEN CHECKING THE “FAIL” LINE ON THE VEMD SYSTEM STATUS PAGE, MAKE SURE TO CHECK ALL FAILURES. TO DO SO, PRESS THE SELECT KEY UNTIL A WHITE FRAME SURROUNDS THE “FAIL” LINE. THEN, USE “+/-” KEY TO VIEW ALL FAILURES. PROCEED THE SAME WAY TO CHECK ALL MESSAGES ON THE “MSG” LINE.

CAUTION: THE FAILURE INFORMATION ON THE VEMD SYSTEM STATUS PAGE MAY NO LONGER BE AVAILABLE AFTER BATTERY POWER IS TURNED OFF. THEREFORE, AFTER A FAILURE OCCURRED, IT IS VERY IMPORTANT TO CHECK AND WRITE DOWN ALL INFORMATION FROM THE “FAIL” LINE AND THE “MSG” LINE BEFORE TURNING BATTERY POWER OFF.

C. POSSIBLE CAUSES

- P3 air transmitter tube
- P3 air pressure transmitter
- Control harness
- EECU

2. PROCEDURE

Effectivity: C1

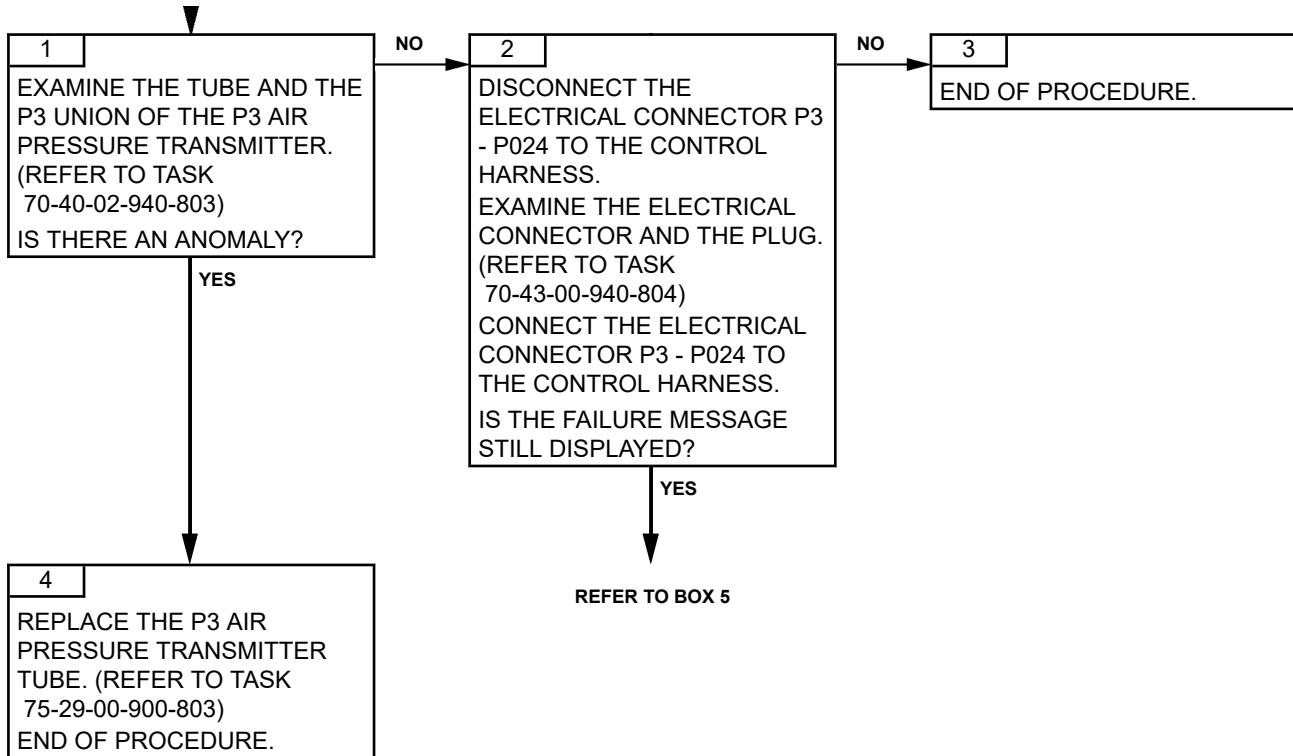

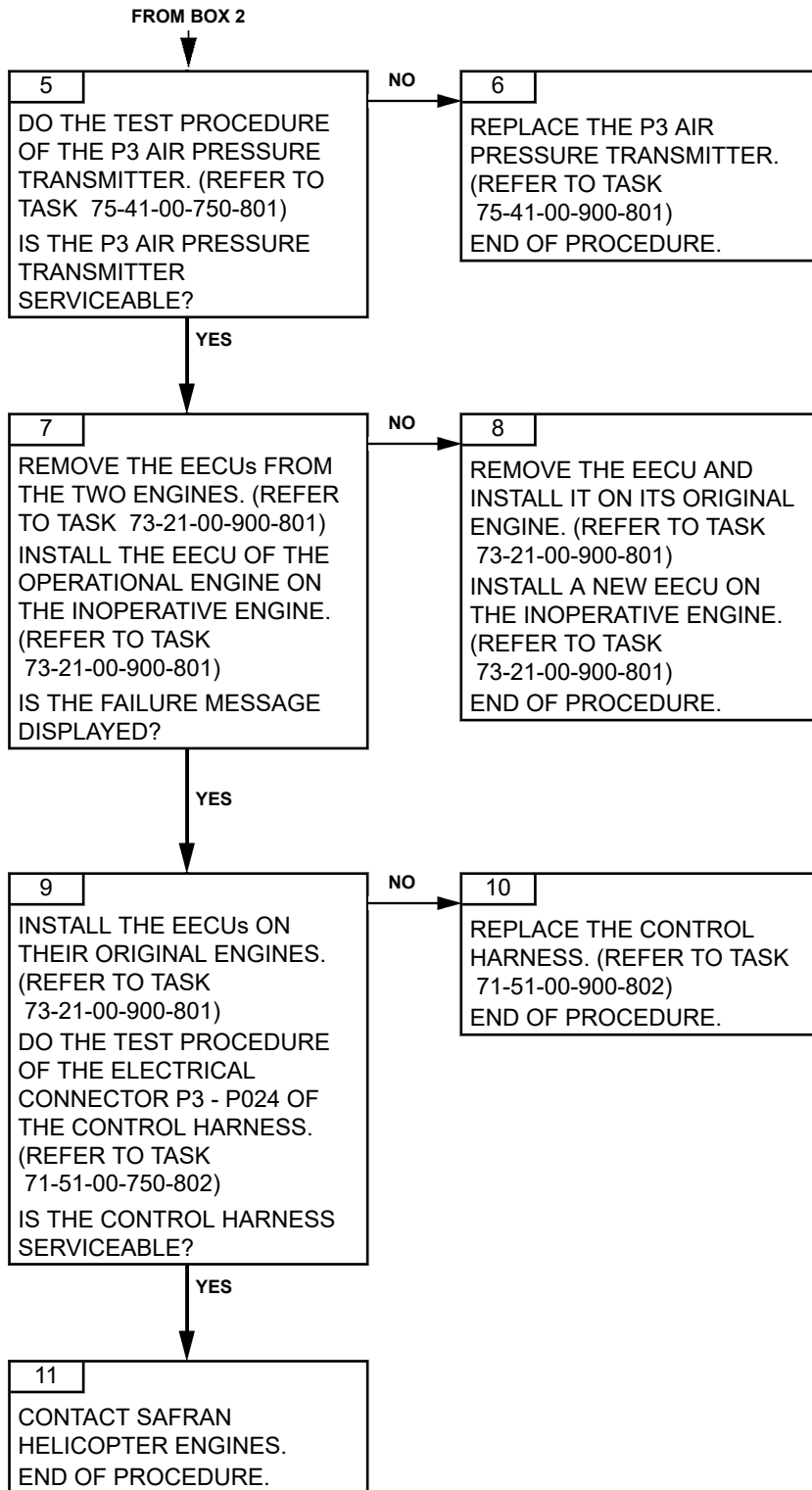

PAGE LEFT BLANK INTENTIONALLY

TASK 71-00-06-817-842-A01

**RAW TORQUE FAILURE
TROUBLESHOOTING****1. GENERAL****A. VEMD FAILURE MESSAGE**

<i>VEMD MESSAGE</i>
TRQ. A or TRQ. B

B. FAILURE EFFECTS

<i>EFFECTS</i>	<i>CAD MESSAGE</i>
<p>If TRQ. A only or if TRQ. A + TRQ. B</p> <ul style="list-style-type: none"> – Inhibition of the torque limitation function. The pilot ensures the MGB protection as a function of the torque indication of the other engine and/or the N1 indication. <p>If TRQ. B only</p> <ul style="list-style-type: none"> – If channel A in control: no effect – If channel B in control following a total failure of channel A: inhibition of the torque limitation function. The pilot ensures the MGB protection as a function of the torque indication of the other engine and/or the N1 indication. 	<p>GOV</p> <p>flashing GOV GOV</p>

CAUTION: MAKE SURE THAT THE CONCERNED AIRCRAFT SYSTEM IS SERVICEABLE BEFORE YOU SWAP THE ENGINE ELECTRONIC CONTROL UNITS.

CAUTION: WHEN CHECKING THE “FAIL” LINE ON THE VEMD SYSTEM STATUS PAGE, MAKE SURE TO CHECK ALL FAILURES. TO DO SO, PRESS THE SELECT KEY UNTIL A WHITE FRAME SURROUNDS THE “FAIL” LINE. THEN, USE “+/-” KEY TO VIEW ALL FAILURES. PROCEED THE SAME WAY TO CHECK ALL MESSAGES ON THE “MSG” LINE.

CAUTION: THE FAILURE INFORMATION ON THE VEMD SYSTEM STATUS PAGE MAY NO LONGER BE AVAILABLE AFTER BATTERY POWER IS TURNED OFF. THEREFORE, AFTER A FAILURE OCCURRED, IT IS VERY IMPORTANT TO CHECK AND WRITE DOWN ALL INFORMATION FROM THE “FAIL” LINE AND THE “MSG” LINE BEFORE TURNING BATTERY POWER OFF.

C. POSSIBLE CAUSES

- EECU
- Torquemeter sensor
- Control harness

2. PROCEDURE

Effectivity: C1

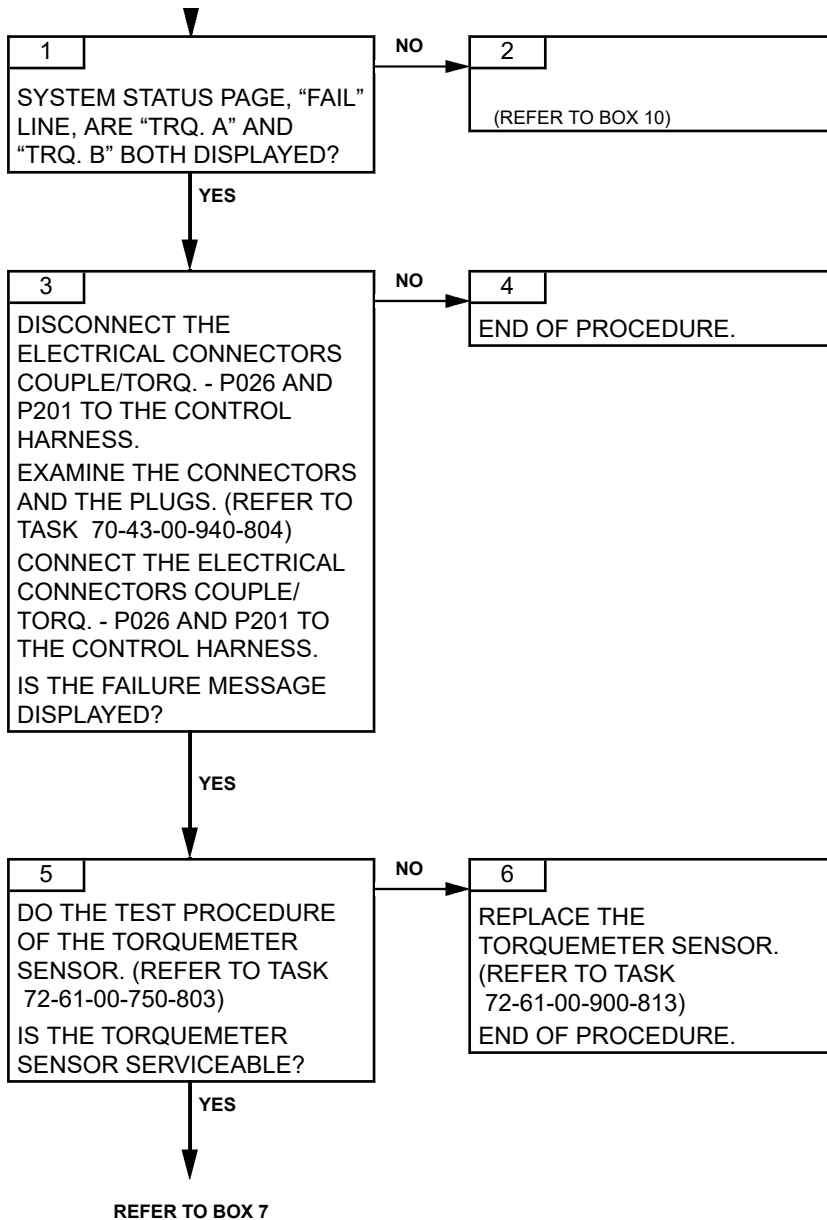

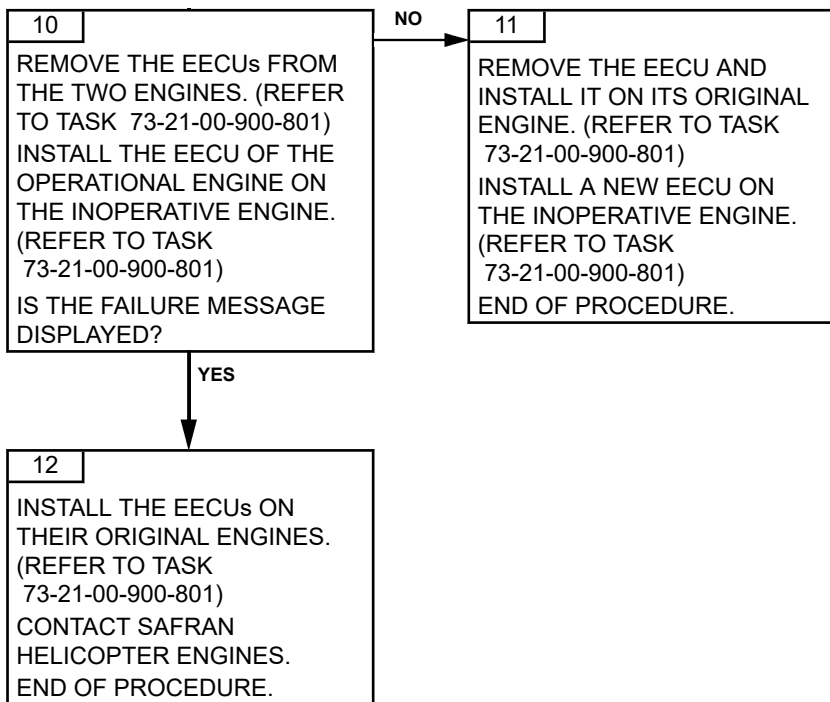
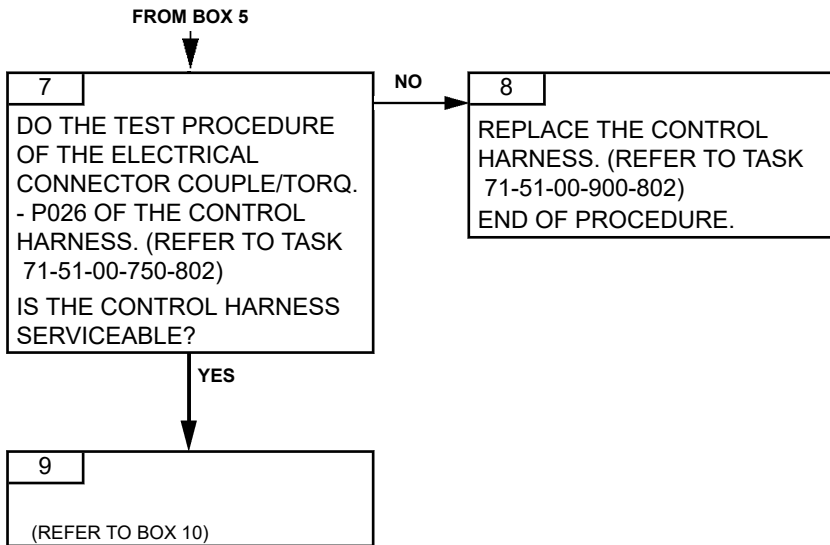

PAGE LEFT BLANK INTENTIONALLY

TASK 71-00-06-817-844-A01

**TOT (T4) CONFORMATION FAIL
TROUBLESHOOTING****1. GENERAL****A. VEMD FAILURE MESSAGE**

<i>VEMD MESSAGE</i>
TOT M. A or TOT M. B

B. FAILURE EFFECTS

<i>EFFECTS</i>	<i>CAD MESSAGE</i>
<p>If TOT M. A only or if TOT M. A + TOT M. B</p> <ul style="list-style-type: none"> – If failure present at power-on: <ul style="list-style-type: none"> • Before end of start: engine still protected for overtemperature during start but start performance degraded • After end of start: no effect. – If failure happens after power-on: <ul style="list-style-type: none"> • EECU uses the conformation value before the failure. No effect. <p>If TOT M. B only</p> <ul style="list-style-type: none"> – If channel A in control: no effect – If channel B in control following total failure of channel A: same effect as “If TOT M. A only or if TOT M. A + TOT M. B”. 	<p>GOV</p> <p>flashing GOV</p> <p>flashing GOV</p> <p>flashing GOV</p>

CAUTION: MAKE SURE THAT THE CONCERNED AIRCRAFT SYSTEM IS SERVICEABLE BEFORE YOU SWAP THE ENGINE ELECTRONIC CONTROL UNITS.

CAUTION: WHEN CHECKING THE “FAIL” LINE ON THE VEMD SYSTEM STATUS PAGE, MAKE SURE TO CHECK ALL FAILURES. TO DO SO, PRESS THE SELECT KEY UNTIL A WHITE FRAME SURROUNDS THE “FAIL” LINE. THEN, USE “+/-” KEY TO VIEW ALL FAILURES. PROCEED THE SAME WAY TO CHECK ALL MESSAGES ON THE “MSG” LINE.

CAUTION: THE FAILURE INFORMATION ON THE VEMD SYSTEM STATUS PAGE MAY NO LONGER BE AVAILABLE AFTER BATTERY POWER IS TURNED OFF. THEREFORE, AFTER A FAILURE OCCURRED, IT IS VERY IMPORTANT TO CHECK AND WRITE DOWN ALL INFORMATION FROM THE “FAIL” LINE AND THE “MSG” LINE BEFORE TURNING BATTERY POWER OFF.

C. POSSIBLE CAUSES

- EECU
- Junction and T4.5 conformation box
- Control harness

2. PROCEDURE

Effectivity: C1

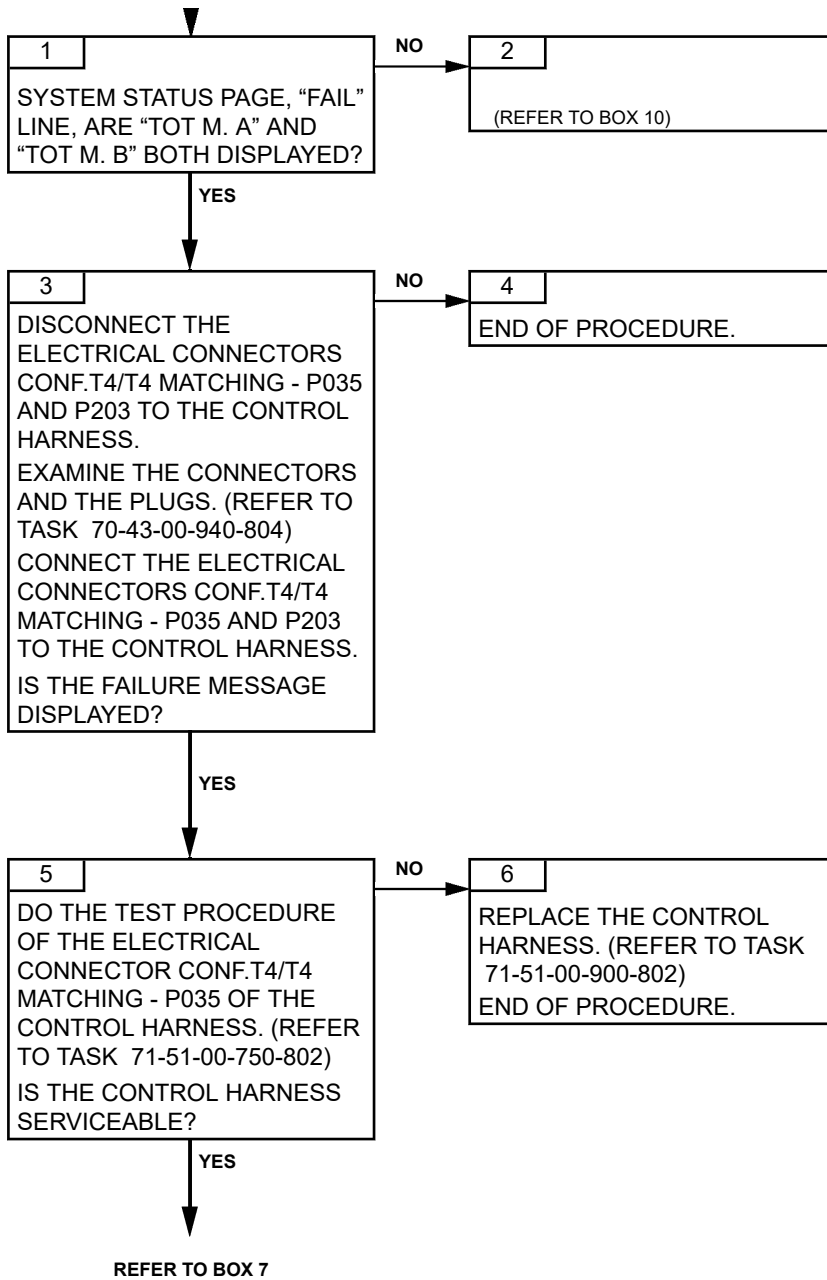

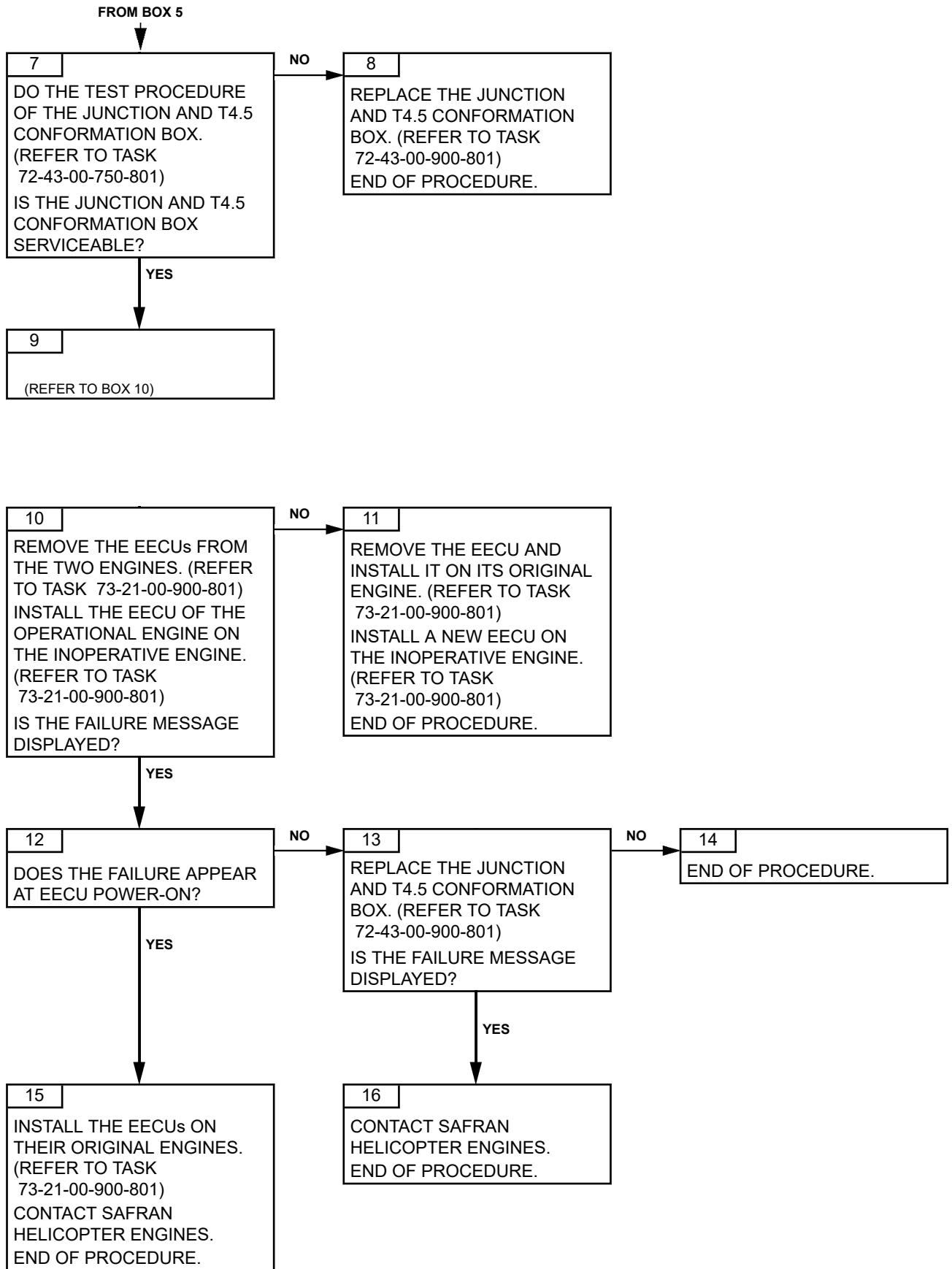

Effectivity: C1

PAGE LEFT BLANK INTENTIONALLY

TASK 71-00-06-817-847-A01

**TORQUE CONFORMATION FAIL
TROUBLESHOOTING****1. GENERAL****A. VEMD FAILURE MESSAGE**

<i>VEMD MESSAGE</i>
TRQ CL. A or TRQ CL. B

B. FAILURE EFFECTS

<i>EFFECTS</i>	<i>CAD MESSAGE</i>
<p>If TRQ CL. A only or if TRQ CL. A + TRQ CL. B</p> <ul style="list-style-type: none"> – If failure present at power-on: use of a backup value to ensure that the engine is still able to provide the minimum torque; the pilot ensures the MGB protection as a function of the N1 and/or the torque of the other engine – If failure happens after power-on: <ul style="list-style-type: none"> • EECU uses the conformation value before the failure. No effect. <p>If TRQ CL. B only</p> <ul style="list-style-type: none"> – If channel A in control: no effect – If channel B in control following total failure of channel A: same effect as “If TRQ CL. A only or if TRQ CL. A + TRQ CL. B”. 	<p>GOV</p> <p>flashing GOV</p> <p>flashing GOV</p>

CAUTION: MAKE SURE THAT THE CONCERNED AIRCRAFT SYSTEM IS SERVICEABLE BEFORE YOU SWAP THE ENGINE ELECTRONIC CONTROL UNITS.

CAUTION: WHEN CHECKING THE “FAIL” LINE ON THE VEMD SYSTEM STATUS PAGE, MAKE SURE TO CHECK ALL FAILURES. TO DO SO, PRESS THE SELECT KEY UNTIL A WHITE FRAME SURROUNDS THE “FAIL” LINE. THEN, USE “+/-” KEY TO VIEW ALL FAILURES. PROCEED THE SAME WAY TO CHECK ALL MESSAGES ON THE “MSG” LINE.

CAUTION: THE FAILURE INFORMATION ON THE VEMD SYSTEM STATUS PAGE MAY NO LONGER BE AVAILABLE AFTER BATTERY POWER IS TURNED OFF. THEREFORE, AFTER A FAILURE OCCURRED, IT IS VERY IMPORTANT TO CHECK AND WRITE DOWN ALL INFORMATION FROM THE “FAIL” LINE AND THE “MSG” LINE BEFORE TURNING BATTERY POWER OFF.

C. POSSIBLE CAUSES

- EECU
- Torque conformation box
- Control harness

2. PROCEDURE

Effectivity: C1

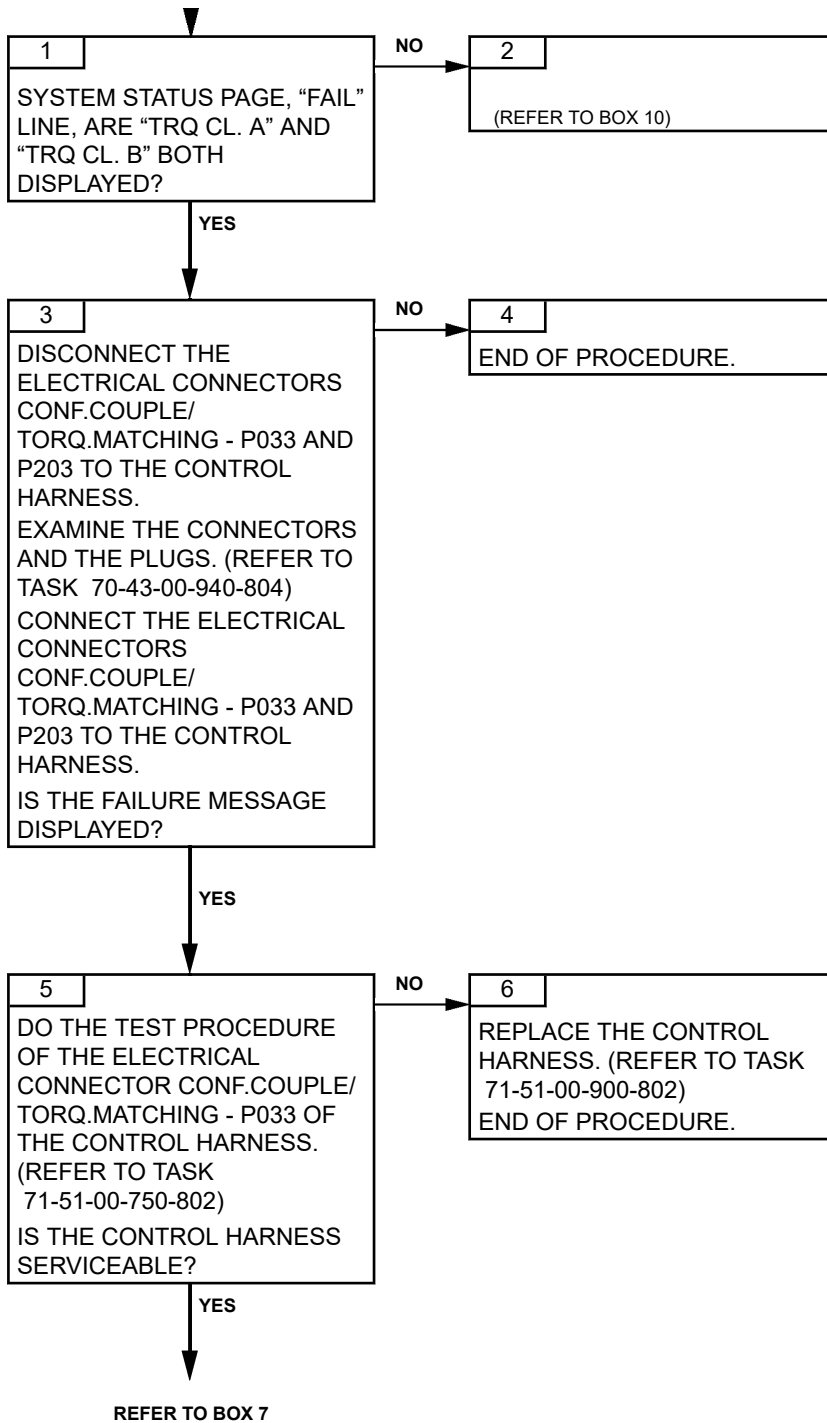

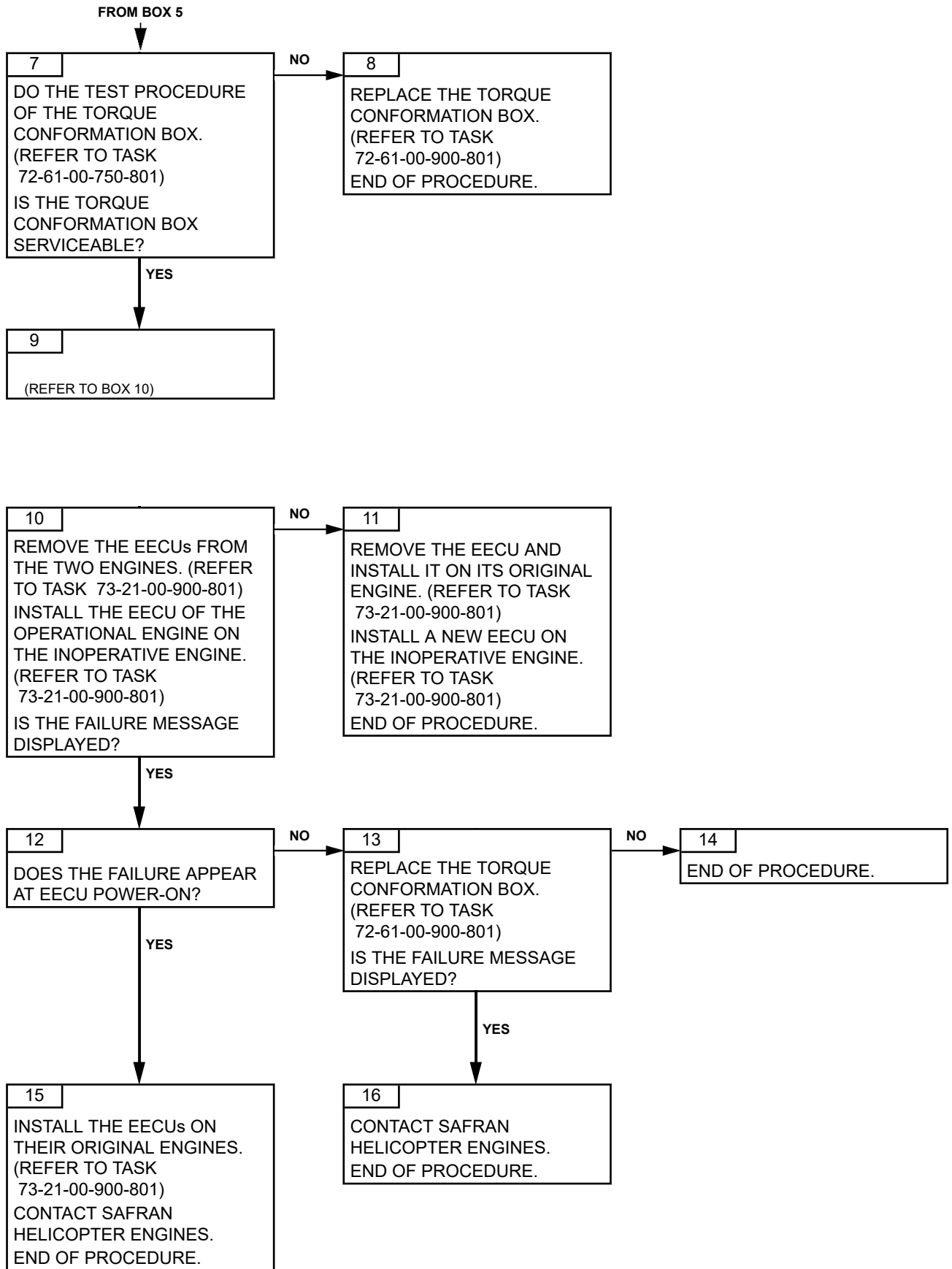

Effectivity: C1

PAGE LEFT BLANK INTENTIONALLY

TASK 71-00-06-817-861-A01

**EECU INTERNAL FAILURE
TROUBLESHOOTING****1. GENERAL****A. VEMD FAILURE MESSAGE**

<i>VEMD MESSAGE</i>
PROCES. A or PROCES. B

B. FAILURE EFFECTS

<i>EFFECTS</i>	<i>CAD MESSAGE</i>
No effect on engine control in automatic mode. Manual mode selection no longer available.	flashing GOV

CAUTION: MAKE SURE THAT THE CONCERNED AIRCRAFT SYSTEM IS SERVICEABLE BEFORE YOU SWAP THE ENGINE ELECTRONIC CONTROL UNITS.

CAUTION: WHEN CHECKING THE “FAIL” LINE ON THE VEMD SYSTEM STATUS PAGE, MAKE SURE TO CHECK ALL FAILURES. TO DO SO, PRESS THE SELECT KEY UNTIL A WHITE FRAME SURROUNDS THE “FAIL” LINE. THEN, USE “+/-” KEY TO VIEW ALL FAILURES. PROCEED THE SAME WAY TO CHECK ALL MESSAGES ON THE “MSG” LINE.

CAUTION: THE FAILURE INFORMATION ON THE VEMD SYSTEM STATUS PAGE MAY NO LONGER BE AVAILABLE AFTER BATTERY POWER IS TURNED OFF. THEREFORE, AFTER A FAILURE OCCURRED, IT IS VERY IMPORTANT TO CHECK AND WRITE DOWN ALL INFORMATION FROM THE “FAIL” LINE AND THE “MSG” LINE BEFORE TURNING BATTERY POWER OFF.

C. POSSIBLE CAUSES

- EECU

2. PROCEDURE

Effectivity: C1

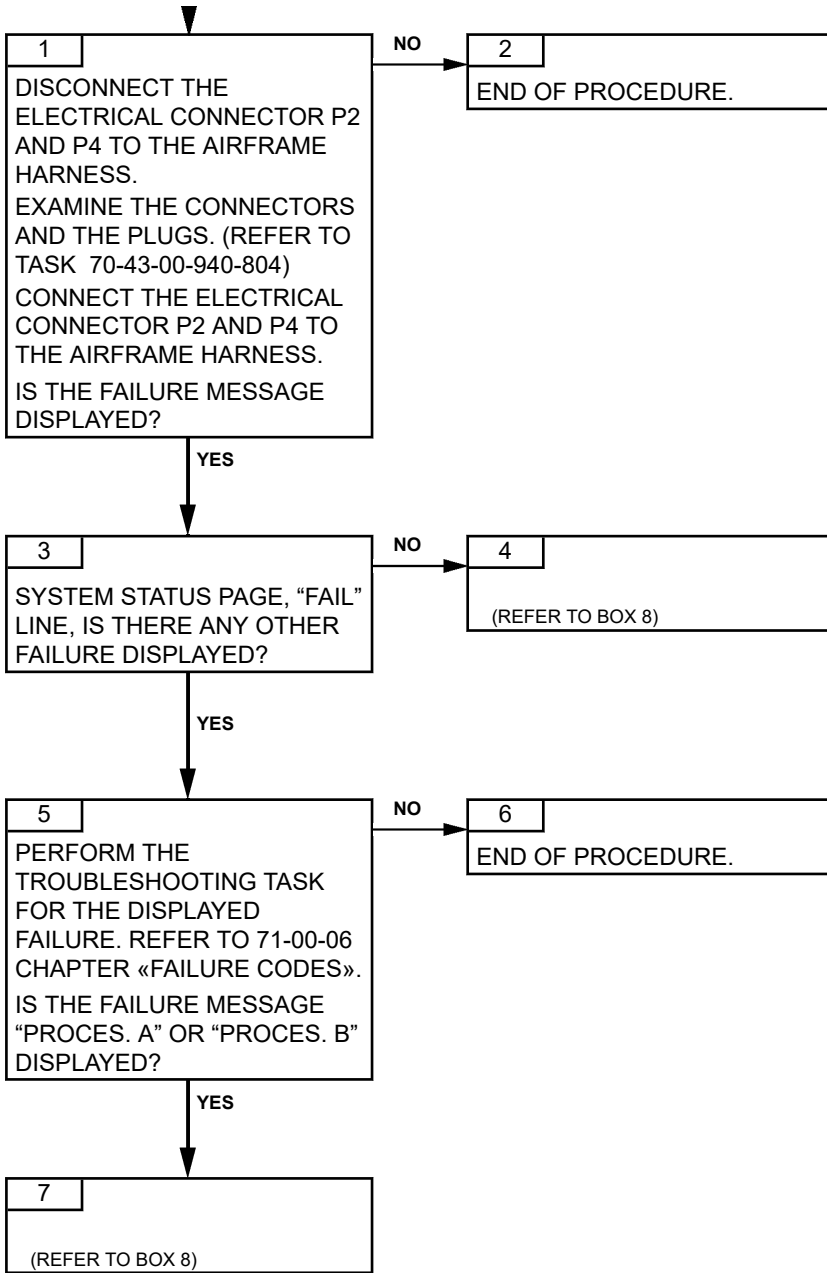

ARRIEL 2 C1

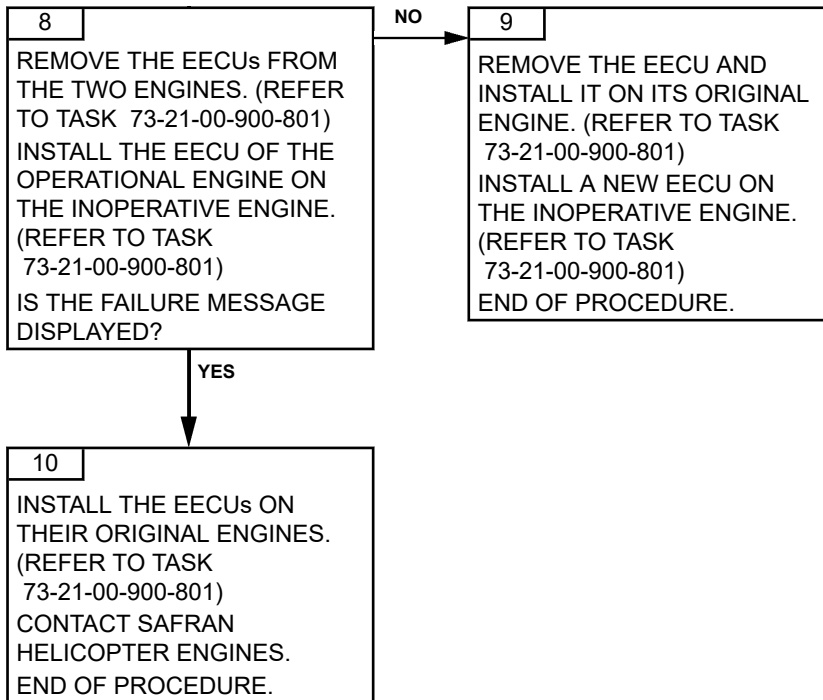

PAGE LEFT BLANK INTENTIONALLY

TASK 71-00-06-817-864-A01

**P3 DRIFT
TROUBLESHOOTING****1. GENERAL****A. VEMD FAILURE MESSAGE**

<i>VEMD MESSAGE</i>
P3/FLA. A or P3/FLA. B

B. FAILURE EFFECTS

<i>EFFECTS</i>	<i>CAD MESSAGE</i>
If P3/FLA. A only or if P3/FLA. A + P3/FLA. B – Degraded transients.	GOV
If P3/FLA. B only – No effect.	flashing GOV

CAUTION: MAKE SURE THAT THE CONCERNED AIRCRAFT SYSTEM IS SERVICEABLE BEFORE YOU SWAP THE ENGINE ELECTRONIC CONTROL UNITS.

CAUTION: WHEN CHECKING THE “FAIL” LINE ON THE VEMD SYSTEM STATUS PAGE, MAKE SURE TO CHECK ALL FAILURES. TO DO SO, PRESS THE SELECT KEY UNTIL A WHITE FRAME SURROUNDS THE “FAIL” LINE. THEN, USE “+/-” KEY TO VIEW ALL FAILURES. PROCEED THE SAME WAY TO CHECK ALL MESSAGES ON THE “MSG” LINE.

CAUTION: THE FAILURE INFORMATION ON THE VEMD SYSTEM STATUS PAGE MAY NO LONGER BE AVAILABLE AFTER BATTERY POWER IS TURNED OFF. THEREFORE, AFTER A FAILURE OCCURRED, IT IS VERY IMPORTANT TO CHECK AND WRITE DOWN ALL INFORMATION FROM THE “FAIL” LINE AND THE “MSG” LINE BEFORE TURNING BATTERY POWER OFF.

C. POSSIBLE CAUSES

- P3 air pressure transmitter tube
- P3 air transmitter
- Pump and metering unit assembly
- EECU
- Control harness
- Engine
- Fuel supply to the engine (aircraft side)

2. PROCEDURE

Effectivity: C1

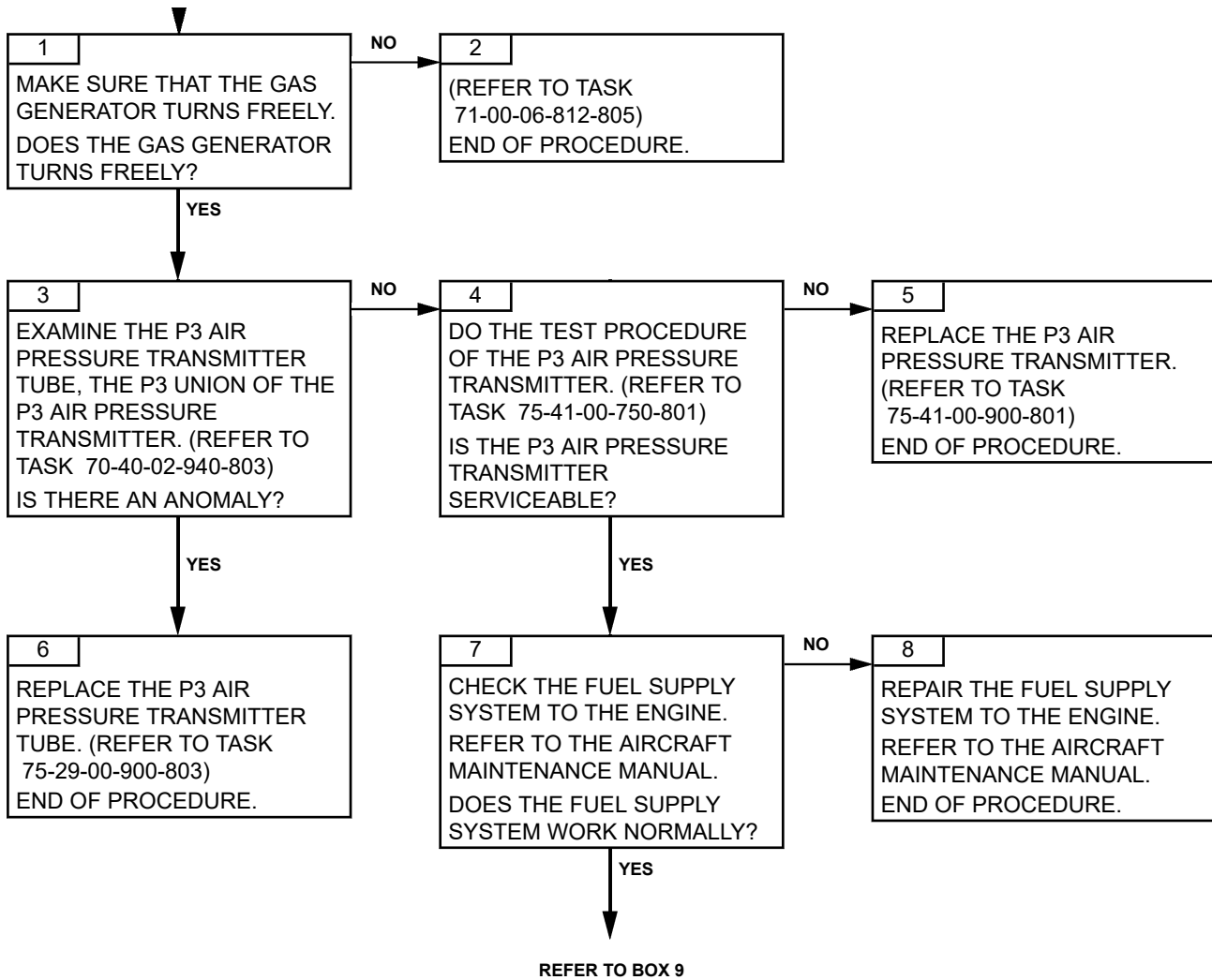

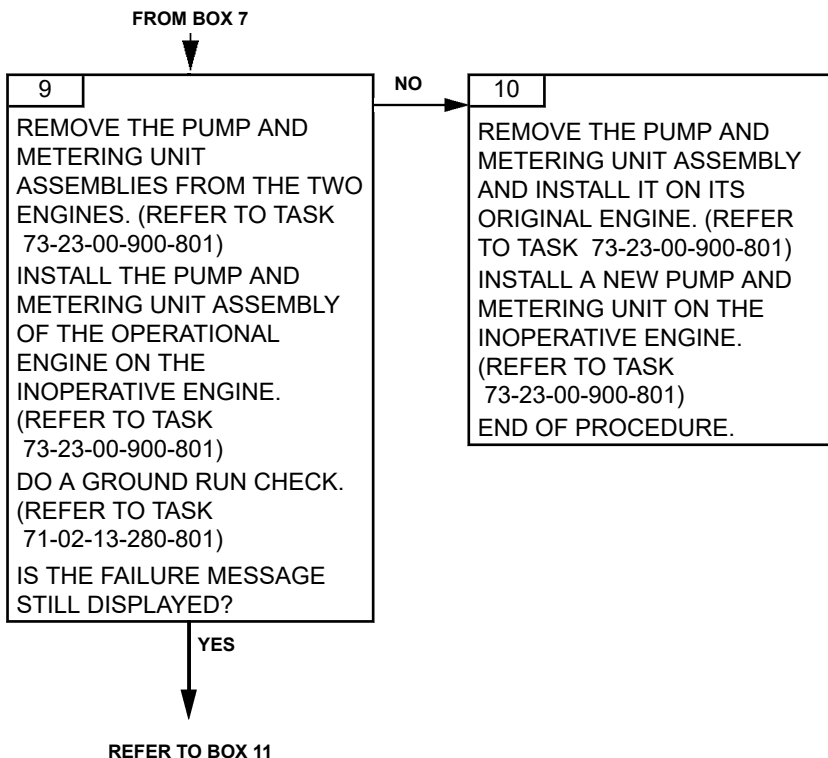

FROM BOX 9

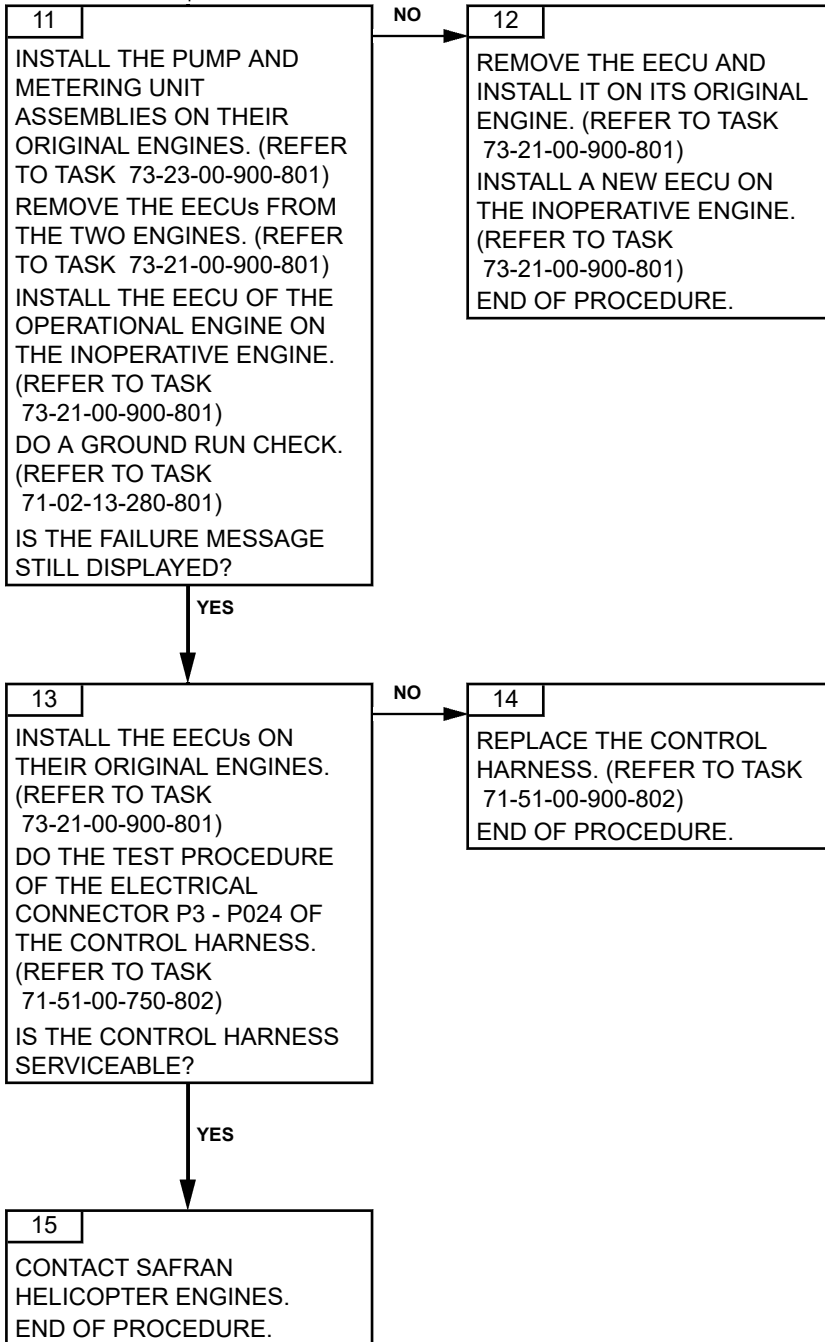

TASK 71-00-06-817-869-A01

P0 EECU TROUBLESHOOTING

1. GENERAL

A. VEMD FAILURE MESSAGE

VEMD MESSAGE
P0. A or P0. B

B. FAILURE EFFECTS

EFFECTS	CAD MESSAGE
<p>If P0. A only or if P0. A + P0. B</p> <ul style="list-style-type: none"> – If valid P0 available from cross-talk ARINC: no effect – If valid P0 not available from cross-talk ARINC: back-up P0 value to have max NG available in the complete flight envelope. Degraded transients, but control laws adapted to avoid surge and flameout in the complete flight envelope. <p>If P0. B only</p> <ul style="list-style-type: none"> – No effect. 	<p>flashing GOV GOV</p> <p>flashing GOV</p>

CAUTION: MAKE SURE THAT THE CONCERNED AIRCRAFT SYSTEM IS SERVICEABLE BEFORE YOU SWAP THE ENGINE ELECTRONIC CONTROL UNITS.

CAUTION: WHEN CHECKING THE “FAIL” LINE ON THE VEMD SYSTEM STATUS PAGE, MAKE SURE TO CHECK ALL FAILURES. TO DO SO, PRESS THE SELECT KEY UNTIL A WHITE FRAME SURROUNDS THE “FAIL” LINE. THEN, USE “+/-” KEY TO VIEW ALL FAILURES. PROCEED THE SAME WAY TO CHECK ALL MESSAGES ON THE “MSG” LINE.

CAUTION: THE FAILURE INFORMATION ON THE VEMD SYSTEM STATUS PAGE MAY NO LONGER BE AVAILABLE AFTER BATTERY POWER IS TURNED OFF. THEREFORE, AFTER A FAILURE OCCURRED, IT IS VERY IMPORTANT TO CHECK AND WRITE DOWN ALL INFORMATION FROM THE “FAIL” LINE AND THE “MSG” LINE BEFORE TURNING BATTERY POWER OFF.

C. POSSIBLE CAUSES

- EECU

2. PROCEDURE

Effectivity: C1

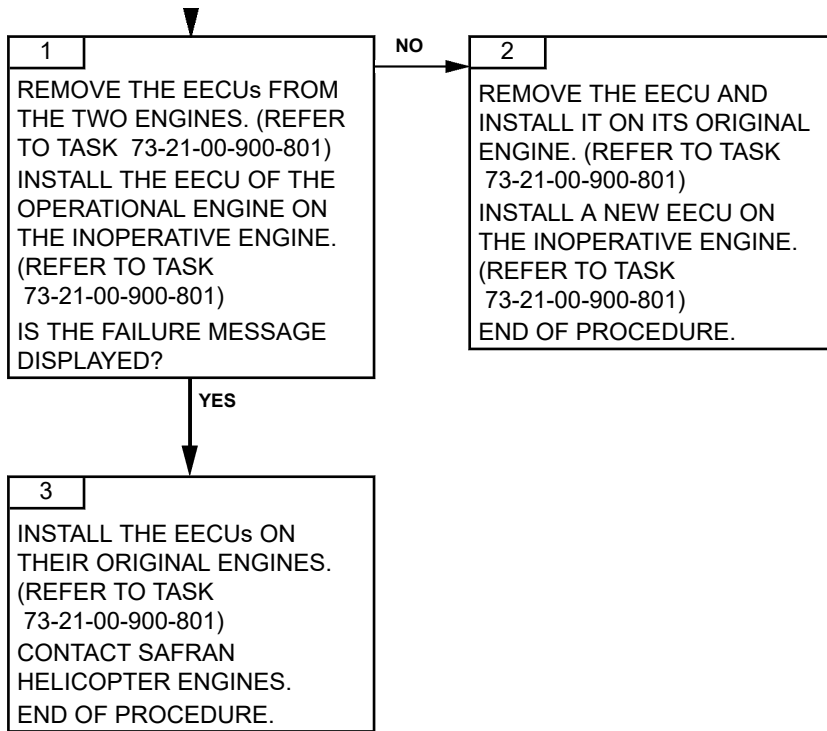

TASK 71-00-06-817-878-A01

**FUEL VALVE RESOLVER FAILURE
TROUBLESHOOTING****1. GENERAL****A. VEMD FAILURE MESSAGE**

<i>VEMD MESSAGE</i>
RESOL. A or RESOL. B

B. FAILURE EFFECTS

<i>EFFECTS</i>	<i>CAD MESSAGE</i>
<u>If RESOL. A only</u>	
– If failure whereas the resolver measurement is required to determine the step-per motor position (power-on self test, channel not in control, manual mode). Total failure. Reversion to channel B	flashing GOV
– Otherwise: no effect on automatic control.	GOV
<u>If RESOL. A + RESOL. B</u>	
– If failure whereas the resolver measurement is required to determine the step-per motor position (power-on self test, channel not in control, manual mode)	FADEC
– Otherwise: no effect on automatic control.	GOV
<u>If RESOL. B only</u>	
– If channel A in control: no effect	
– If channel B in control after total failure of channel A: same effect as “If RESOL. A + RESOL. B”.	flashing GOV

CAUTION: MAKE SURE THAT THE CONCERNED AIRCRAFT SYSTEM IS SERVICEABLE BEFORE YOU SWAP THE ENGINE ELECTRONIC CONTROL UNITS.

CAUTION: WHEN CHECKING THE “FAIL” LINE ON THE VEMD SYSTEM STATUS PAGE, MAKE SURE TO CHECK ALL FAILURES. TO DO SO, PRESS THE SELECT KEY UNTIL A WHITE FRAME SURROUNDS THE “FAIL” LINE. THEN, USE “+/-” KEY TO VIEW ALL FAILURES. PROCEED THE SAME WAY TO CHECK ALL MESSAGES ON THE “MSG” LINE.

CAUTION: THE FAILURE INFORMATION ON THE VEMD SYSTEM STATUS PAGE MAY NO LONGER BE AVAILABLE AFTER BATTERY POWER IS TURNED OFF. THEREFORE, AFTER A FAILURE OCCURRED, IT IS VERY IMPORTANT TO CHECK AND WRITE DOWN ALL INFORMATION FROM THE “FAIL” LINE AND THE “MSG” LINE BEFORE TURNING BATTERY POWER OFF.

C. POSSIBLE CAUSES

- EECU
- Pump and metering unit assembly
- Control harness

Effectivity: C1

2. PROCEDURE

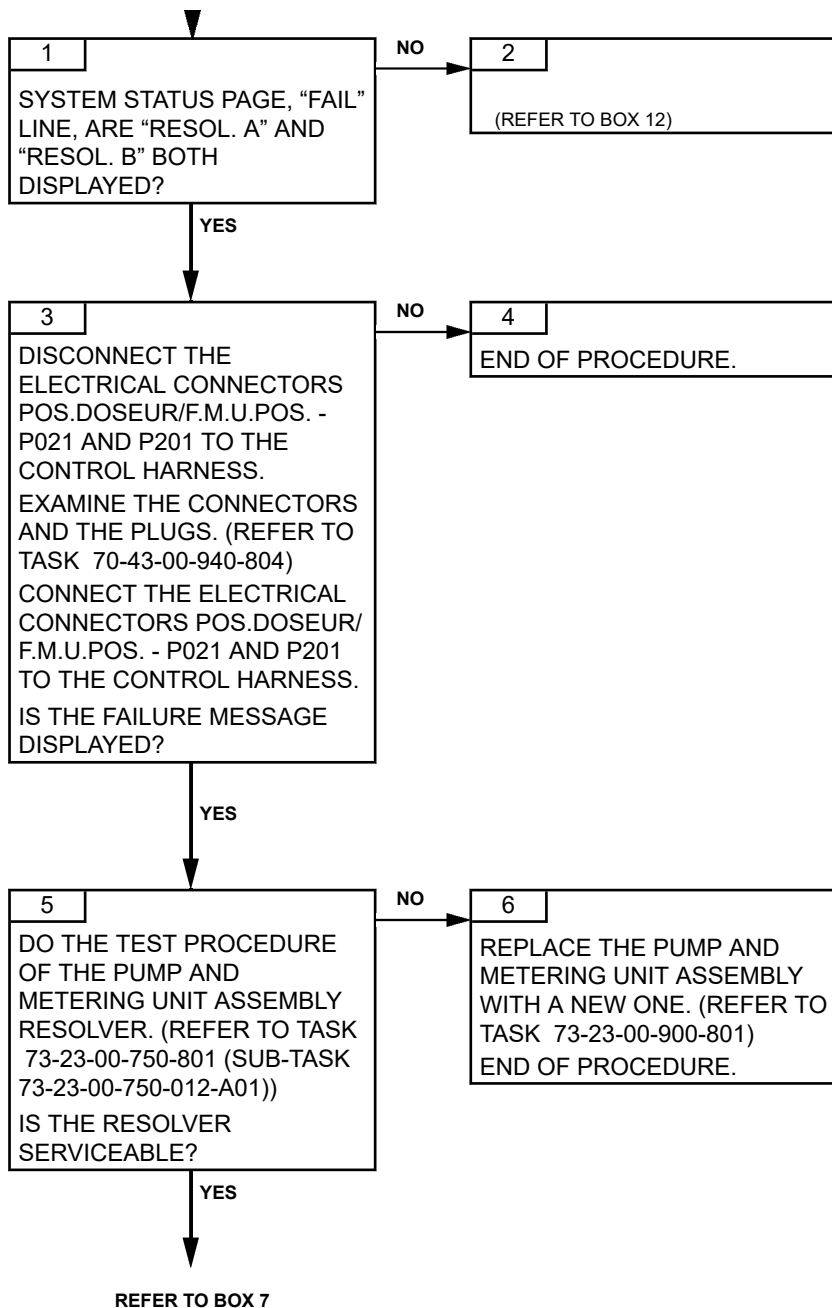

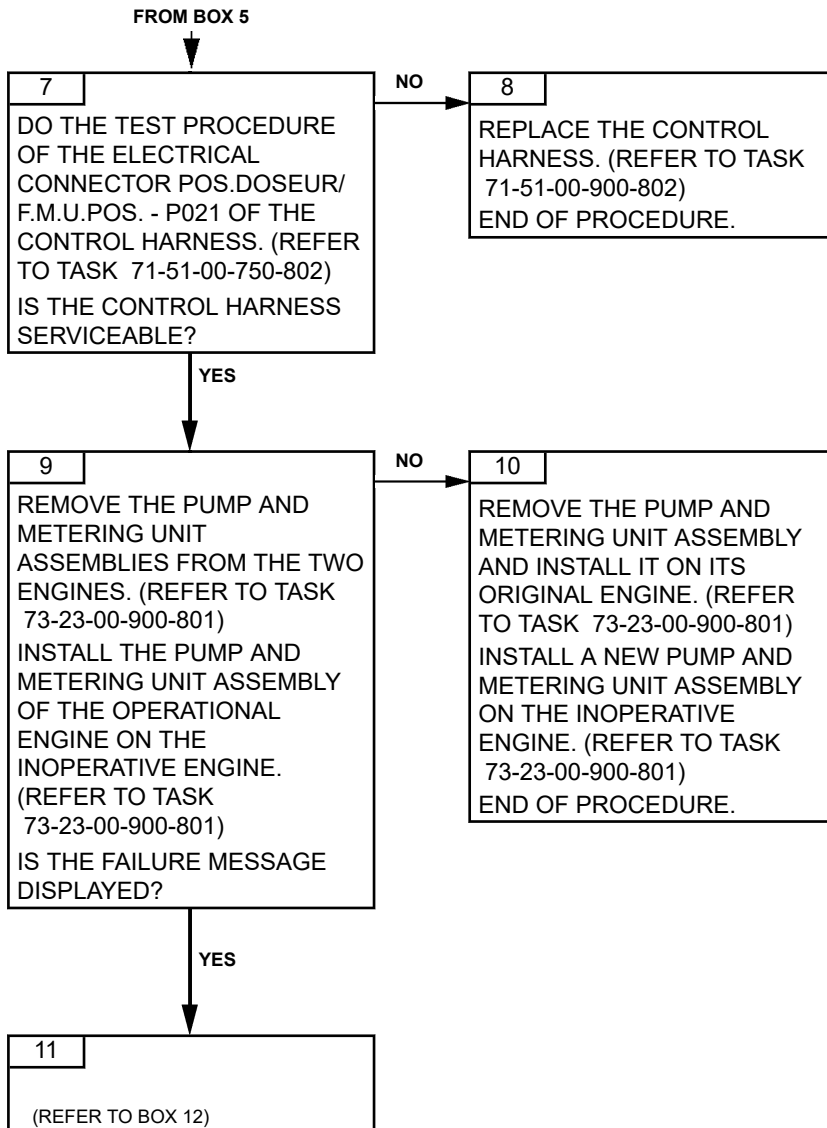

ARRIEL 2 C1

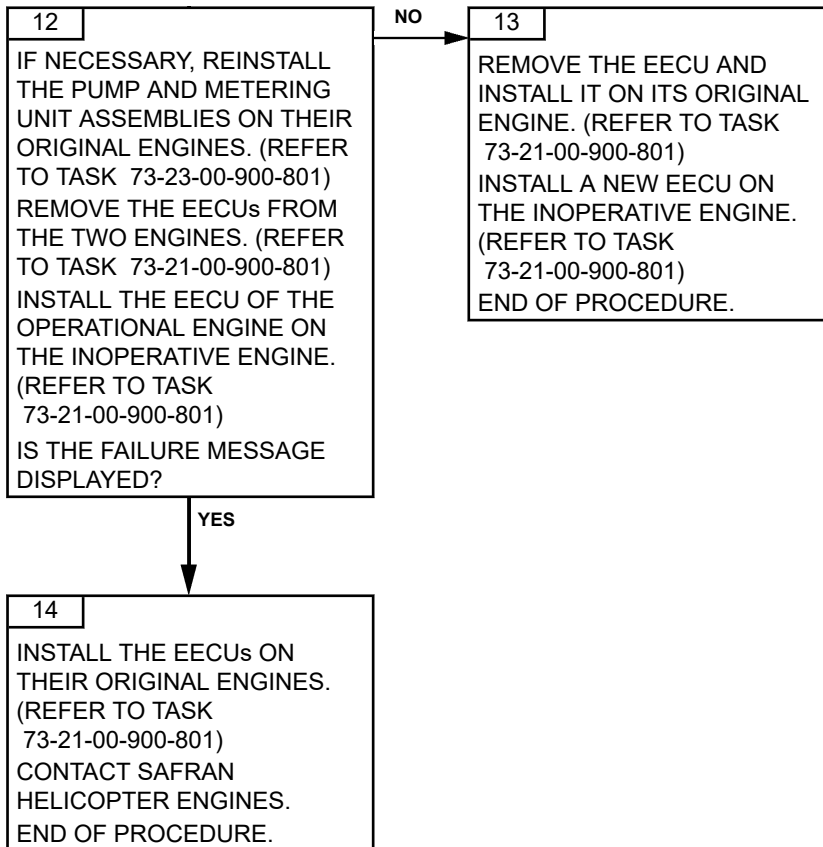

Effectivity: C1

PAGE LEFT BLANK INTENTIONALLY

TASK 71-00-06-817-880-A01

**STEPPER MOTOR FAILURE A
TROUBLESHOOTING****1. GENERAL****A. VEMD FAILURE MESSAGE**

<i>VEMD MESSAGE</i>
STEP M. A (and STEP M. B not displayed)

B. FAILURE EFFECTS

<i>EFFECTS</i>	<i>CAD MESSAGE</i>
Total failure of channel A. Automatic reversion to channel B.	flashing GOV

CAUTION: MAKE SURE THAT THE CONCERNED AIRCRAFT SYSTEM IS SERVICEABLE BEFORE YOU SWAP THE ENGINE ELECTRONIC CONTROL UNITS.

CAUTION: WHEN CHECKING THE “FAIL” LINE ON THE VEMD SYSTEM STATUS PAGE, MAKE SURE TO CHECK ALL FAILURES. TO DO SO, PRESS THE SELECT KEY UNTIL A WHITE FRAME SURROUNDS THE “FAIL” LINE. THEN, USE “+/-” KEY TO VIEW ALL FAILURES. PROCEED THE SAME WAY TO CHECK ALL MESSAGES ON THE “MSG” LINE.

CAUTION: THE FAILURE INFORMATION ON THE VEMD SYSTEM STATUS PAGE MAY NO LONGER BE AVAILABLE AFTER BATTERY POWER IS TURNED OFF. THEREFORE, AFTER A FAILURE OCCURRED, IT IS VERY IMPORTANT TO CHECK AND WRITE DOWN ALL INFORMATION FROM THE “FAIL” LINE AND THE “MSG” LINE BEFORE TURNING BATTERY POWER OFF.

C. POSSIBLE CAUSES

- Pump and metering unit assembly
- EECU
- Control harness

2. PROCEDURE

Effectivity: C1

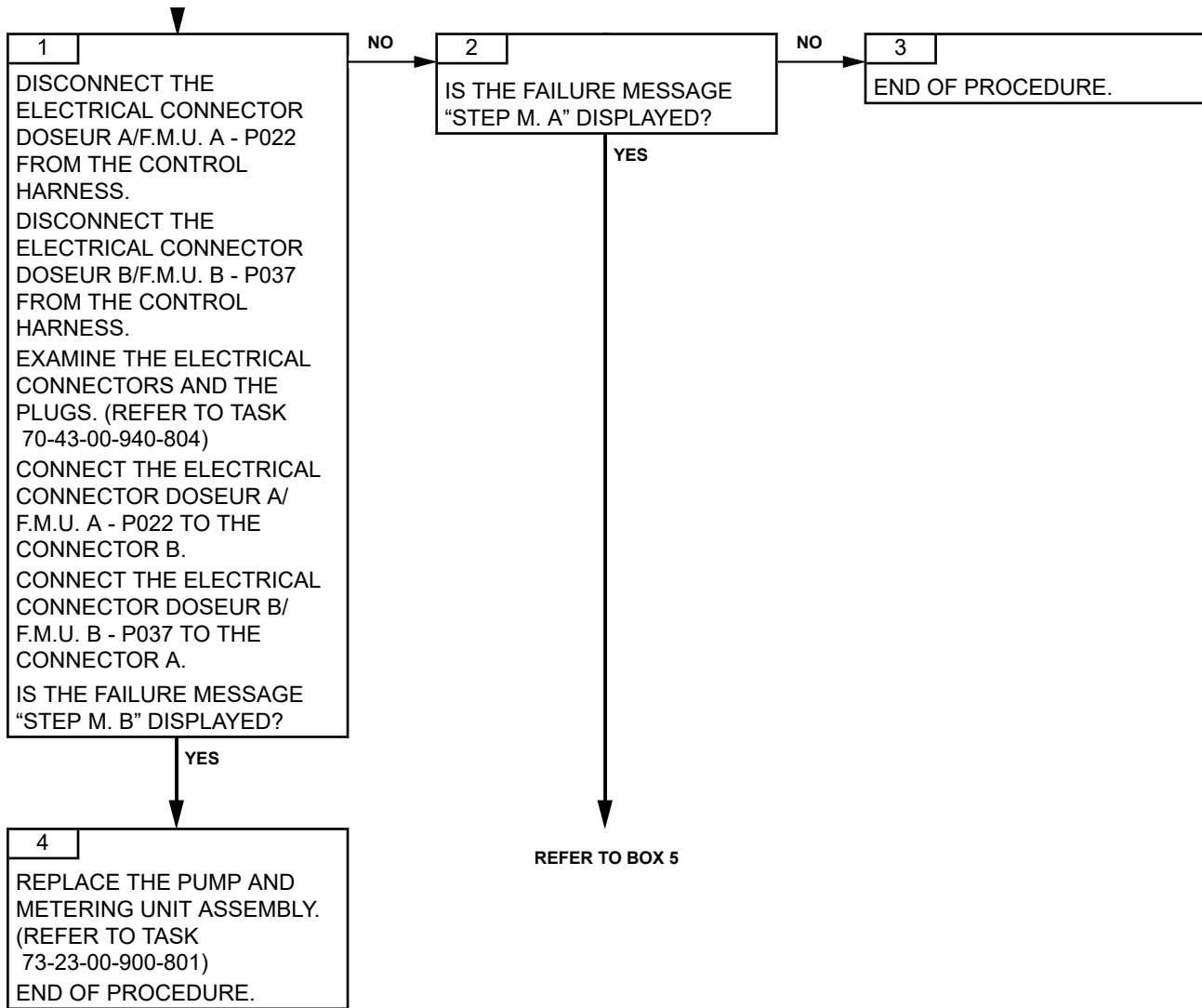

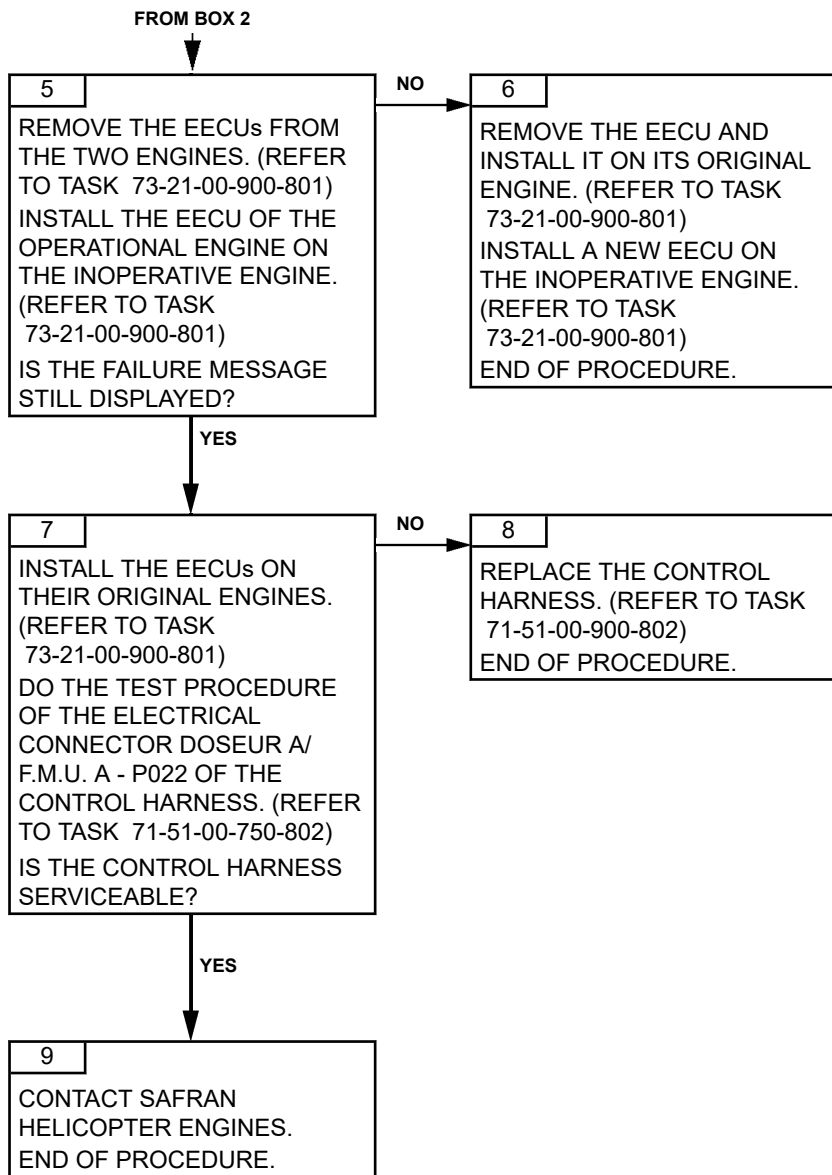

PAGE LEFT BLANK INTENTIONALLY

TASK 71-00-06-817-881-A01

**STEPPER MOTOR FAILURE B
TROUBLESHOOTING****1. GENERAL****A. VEMD FAILURE MESSAGE**

<i>VEMD MESSAGE</i>
STEP M. B (and STEP M. A not displayed)

B. FAILURE EFFECTS

<i>EFFECTS</i>	<i>CAD MESSAGE</i>
Total failure of channel B. No effect, as long as channel A is in control.	flashing GOV

CAUTION: MAKE SURE THAT THE CONCERNED AIRCRAFT SYSTEM IS SERVICEABLE BEFORE YOU SWAP THE ENGINE ELECTRONIC CONTROL UNITS.

CAUTION: WHEN CHECKING THE “FAIL” LINE ON THE VEMD SYSTEM STATUS PAGE, MAKE SURE TO CHECK ALL FAILURES. TO DO SO, PRESS THE SELECT KEY UNTIL A WHITE FRAME SURROUNDS THE “FAIL” LINE. THEN, USE “+/-” KEY TO VIEW ALL FAILURES. PROCEED THE SAME WAY TO CHECK ALL MESSAGES ON THE “MSG” LINE.

CAUTION: THE FAILURE INFORMATION ON THE VEMD SYSTEM STATUS PAGE MAY NO LONGER BE AVAILABLE AFTER BATTERY POWER IS TURNED OFF. THEREFORE, AFTER A FAILURE OCCURRED, IT IS VERY IMPORTANT TO CHECK AND WRITE DOWN ALL INFORMATION FROM THE “FAIL” LINE AND THE “MSG” LINE BEFORE TURNING BATTERY POWER OFF.

C. POSSIBLE CAUSES

- Pump and metering unit assembly
- EECU
- Control harness

2. PROCEDURE

Effectivity: C1

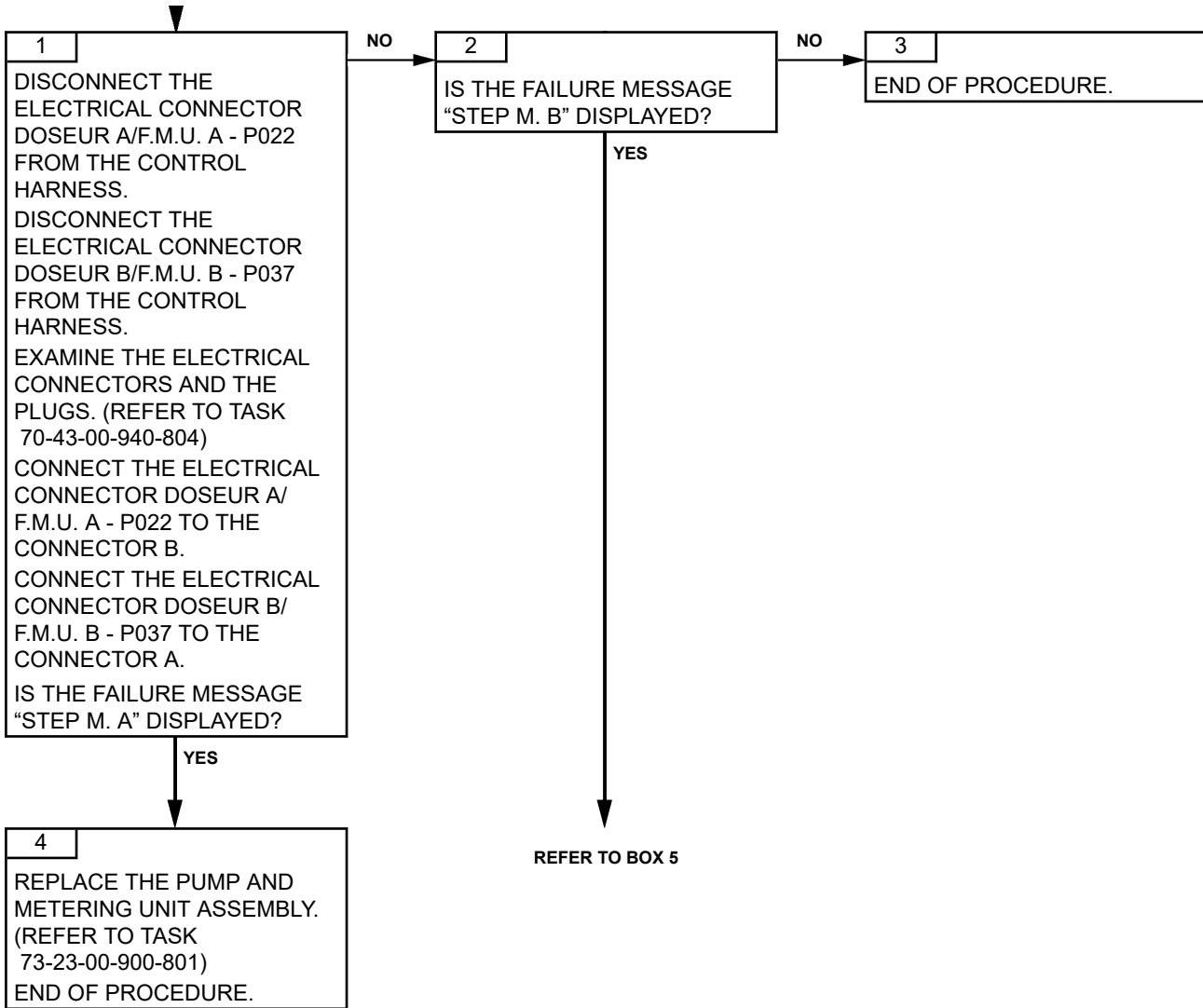

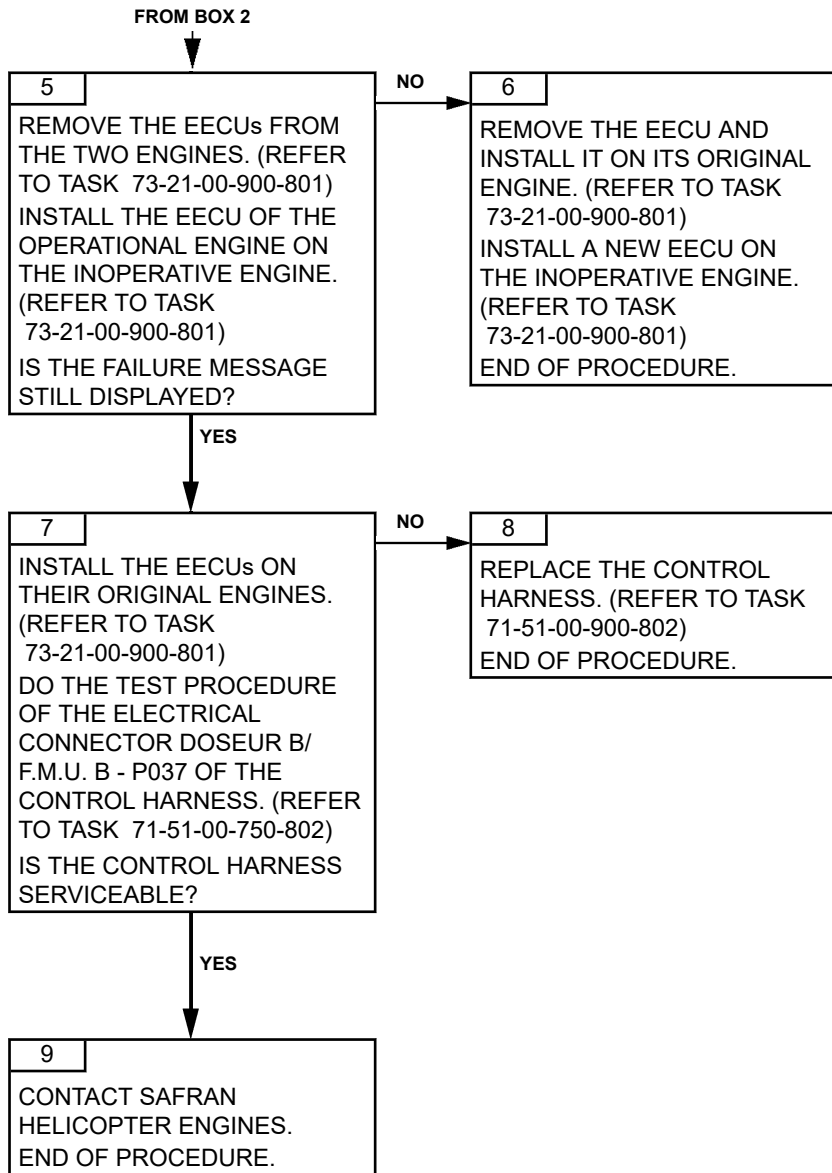

PAGE LEFT BLANK INTENTIONALLY

TASK 71-00-06-817-882-A01

**STEPPER MOTOR FAILURE
TROUBLESHOOTING****1. GENERAL****A. VEMD FAILURE MESSAGE**

<i>VEMD MESSAGE</i>
STEP M. A and STEP M. B

B. FAILURE EFFECTS

<i>EFFECTS</i>	<i>CAD MESSAGE</i>
Total failure of both channels A and B. Stepper motor freezing.	FADEC

CAUTION: MAKE SURE THAT THE CONCERNED AIRCRAFT SYSTEM IS SERVICEABLE BEFORE YOU SWAP THE ENGINE ELECTRONIC CONTROL UNITS.

CAUTION: WHEN CHECKING THE “FAIL” LINE ON THE VEMD SYSTEM STATUS PAGE, MAKE SURE TO CHECK ALL FAILURES. TO DO SO, PRESS THE SELECT KEY UNTIL A WHITE FRAME SURROUNDS THE “FAIL” LINE. THEN, USE “+/-” KEY TO VIEW ALL FAILURES. PROCEED THE SAME WAY TO CHECK ALL MESSAGES ON THE “MSG” LINE.

CAUTION: THE FAILURE INFORMATION ON THE VEMD SYSTEM STATUS PAGE MAY NO LONGER BE AVAILABLE AFTER BATTERY POWER IS TURNED OFF. THEREFORE, AFTER A FAILURE OCCURRED, IT IS VERY IMPORTANT TO CHECK AND WRITE DOWN ALL INFORMATION FROM THE “FAIL” LINE AND THE “MSG” LINE BEFORE TURNING BATTERY POWER OFF.

C. POSSIBLE CAUSES

- Pump and metering unit assembly
- EECU
- Control harness

2. PROCEDURE

Effectivity: C1

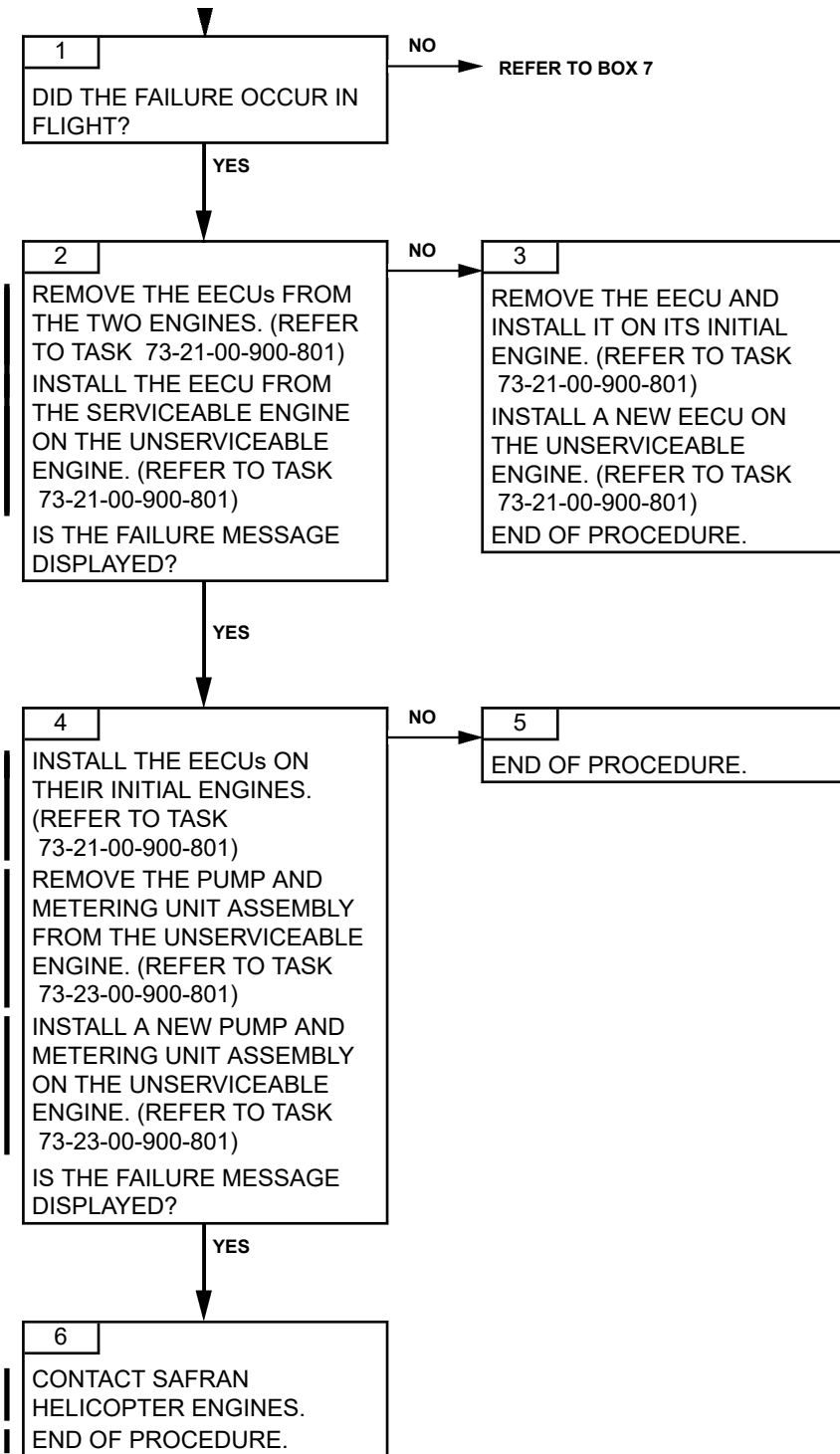

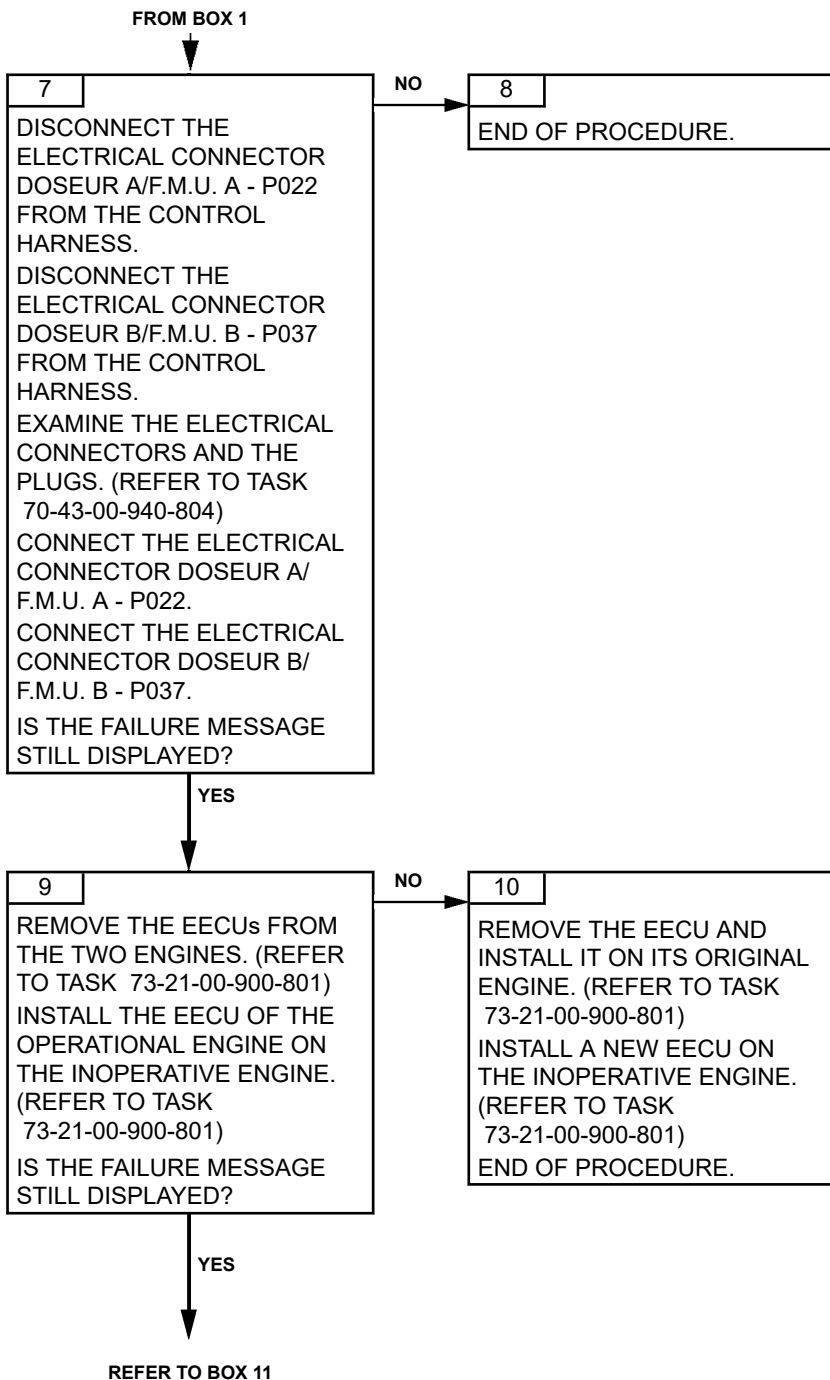

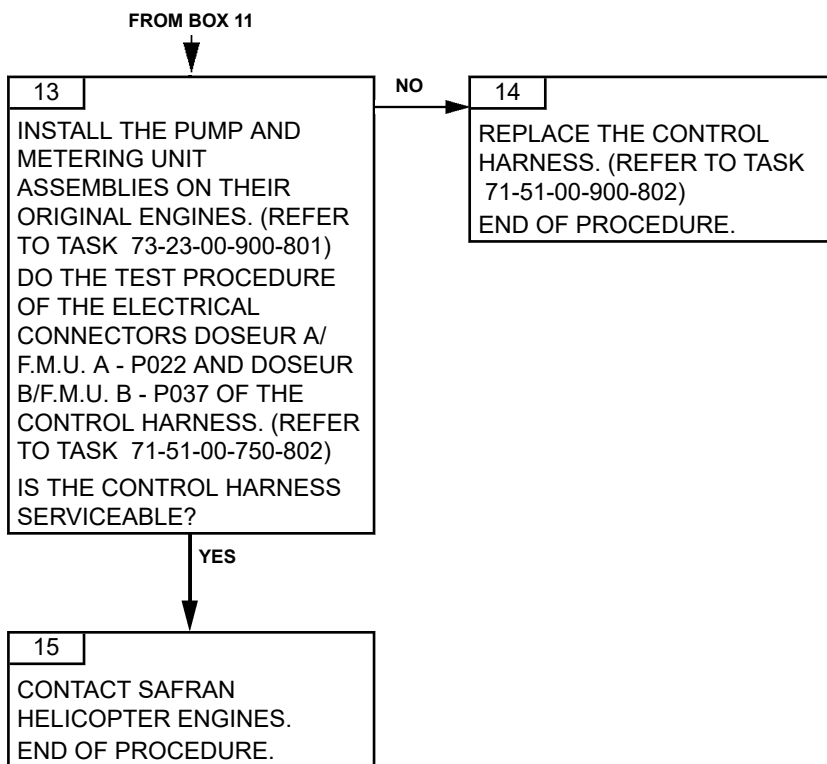
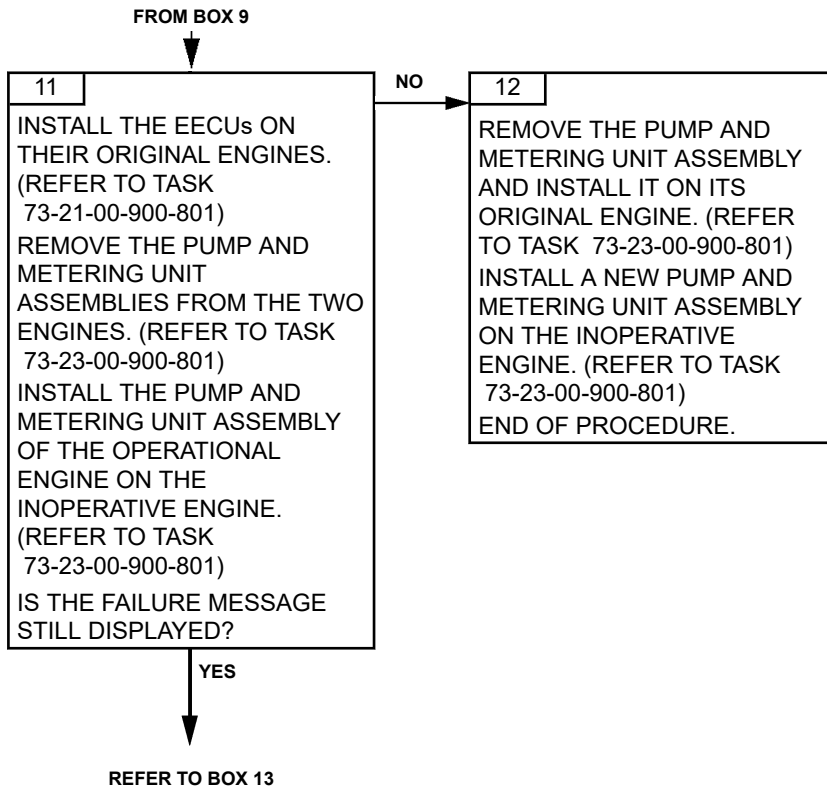

TASK 71-00-06-817-884-A01

BLEED VALVE POSITION INCONSISTENCY OR BLEED VALVE ANOMALY OBSERVED TROUBLESHOOTING

1. GENERAL

A. VEMD FAILURE MESSAGE

VEMD MESSAGE
BV. A or BV. B

CAUTION: MAKE SURE THAT THE CONCERNED AIRCRAFT SYSTEM IS SERVICEABLE BEFORE YOU SWAP THE ENGINE ELECTRONIC CONTROL UNITS.

CAUTION: WHEN CHECKING THE "FAIL" LINE ON THE VEMD SYSTEM STATUS PAGE, MAKE SURE TO CHECK ALL FAILURES. TO DO SO, PRESS THE SELECT KEY UNTIL A WHITE FRAME SURROUNDS THE "FAIL" LINE. THEN, USE "+/-" KEY TO VIEW ALL FAILURES. PROCEED THE SAME WAY TO CHECK ALL MESSAGES ON THE "MSG" LINE.

CAUTION: THE FAILURE INFORMATION ON THE VEMD SYSTEM STATUS PAGE MAY NO LONGER BE AVAILABLE AFTER BATTERY POWER IS TURNED OFF. THEREFORE, AFTER A FAILURE OCCURRED, IT IS VERY IMPORTANT TO CHECK AND WRITE DOWN ALL INFORMATION FROM THE "FAIL" LINE AND THE "MSG" LINE BEFORE TURNING BATTERY POWER OFF.

B. GENERAL DESCRIPTION

The bleed valve opening and closing are not controlled by the EECU. The P3/P0 ratio controls the bleed valve opening and closing. A position detector (microswitch) sends the position signal of the bleed valve to the EECU.

During the starting phase, the bleed valve is open until a sufficient P3/P0 ratio is obtained to close the bleed valve. During the rundown phase, the bleed valve is closed until P0/P3 ratio becomes sufficiently low to open the bleed valve.

The failure message "BV.A and/or BV.B" is displayed when the position data received by the EECU is inconsistent with the bleed valve position calculated by the EECU.

This troubleshooting task can be applied when either the failure message "BV.A or BV.B" is displayed or a bleed valve anomaly is observed.

There is a risk of surge if the bleed valve is stuck closed or the maximum power is not available if the bleed valve is stuck open.

C. POSSIBLE CAUSES

- Bleed valve
- Bleed valve filter
- P3 air tube
- EECU
- Control harness

Effectivity: C1

- Microswitch (position detector) of the bleed valve

2. **PROCEDURE**

NOTE: *If the failure is recorded by both EECU channels A and B, the failure is likely to be external to the EECU. If the failure is seen only by channel A or channel B, the failure is likely to be internal to the EECU.*

ARRIEL 2 C1

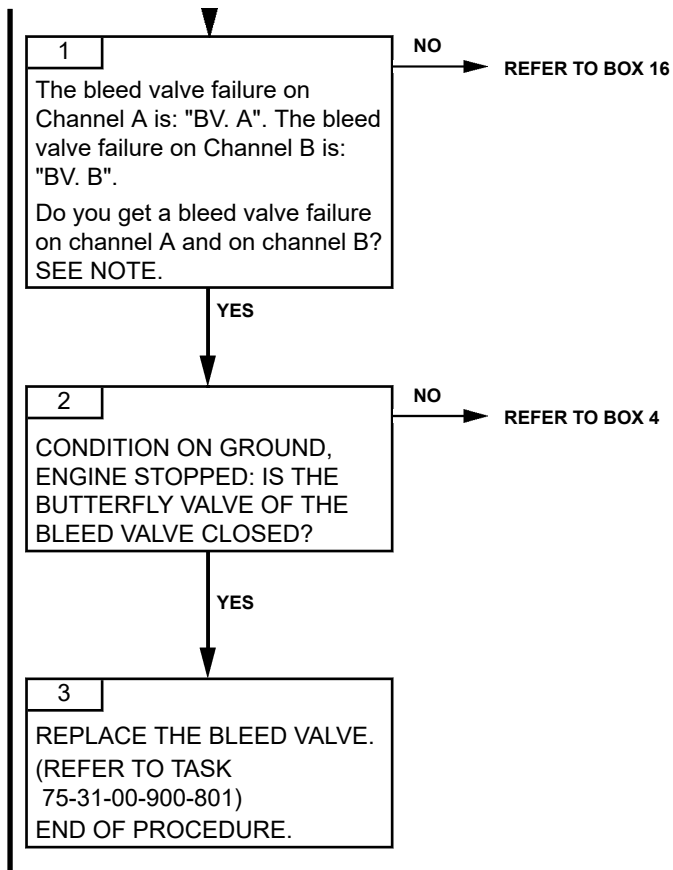

FROM BOX 2



4

NO

REFER TO BOX 6

DE-ENERGIZE THE EECU AND RECORD HOW TO GET THE FAILURE MESSAGE AGAIN: "POWER-ON OF THE EECU" OR "ENGINE GROUND RUN". IF NONE OF THESE PROCEDURES CAN GET THE FAILURE MESSAGE AGAIN, DO NOT DO A TECHNICAL FLIGHT.

DISCONNECT THE ELECTRICAL CONNECTORS P023 FROM THE POSITION DETECTOR OF THE AIR BLEED VALVE.

DISCONNECT THE ELECTRICAL CONNECTORS P201 FROM THE EECU. EXAMINE THE ELECTRICAL CONNECTORS. (REFER TO TASK 70-43-00-940-804)

IF THERE IS A DAMAGE ON THE CONTROL HARNESS, REMOVE THE CONTROL HARNESS AND INSTALL A SERVICEABLE CONTROL HARNESS. (REFER TO TASK 71-51-00-900-802)

IF THERE IS A DAMAGE ON THE AIR BLEED VALVE, REMOVE THE AIR BLEED VALVE AND INSTALL A SERVICEABLE AIR BLEED VALVE. (REFER TO TASK 75-31-00-900-801)

IF THERE IS A DAMAGE ON THE EECU, REMOVE THE EECU AND INSTALL A SERVICEABLE EECU. (REFER TO TASK 73-21-00-900-801)

DID YOU REPAIR OR REPLACE SOMETHING DURING THE PROCEDURE?

YES



REFER TO BOX 5

ARRIEL 2 C1

FROM BOX 4



5

END OF PROCEDURE.

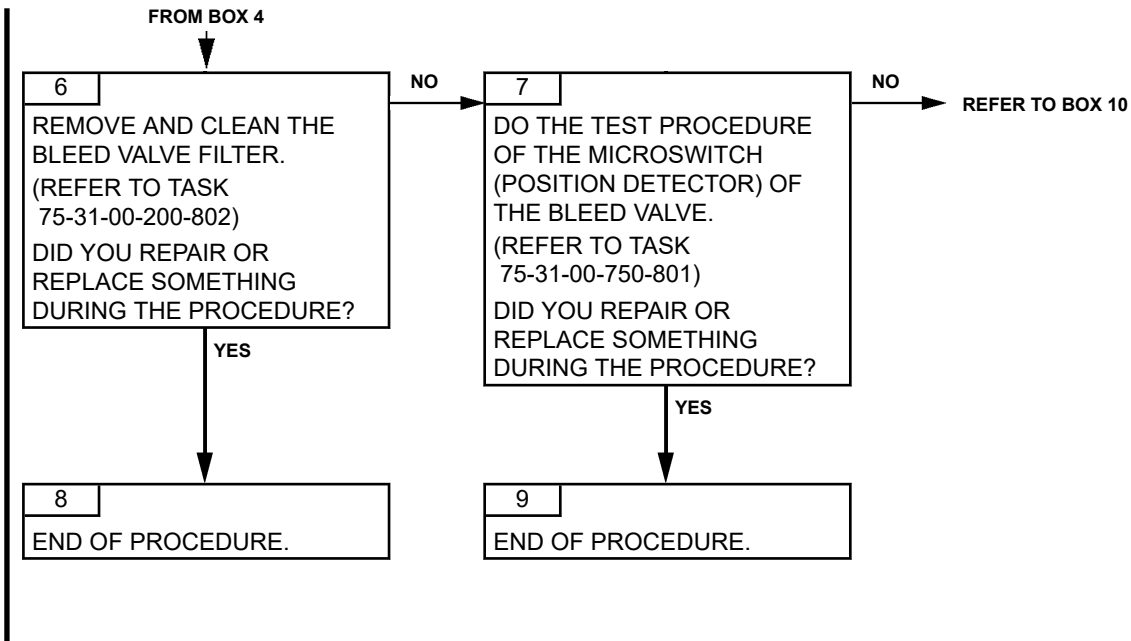

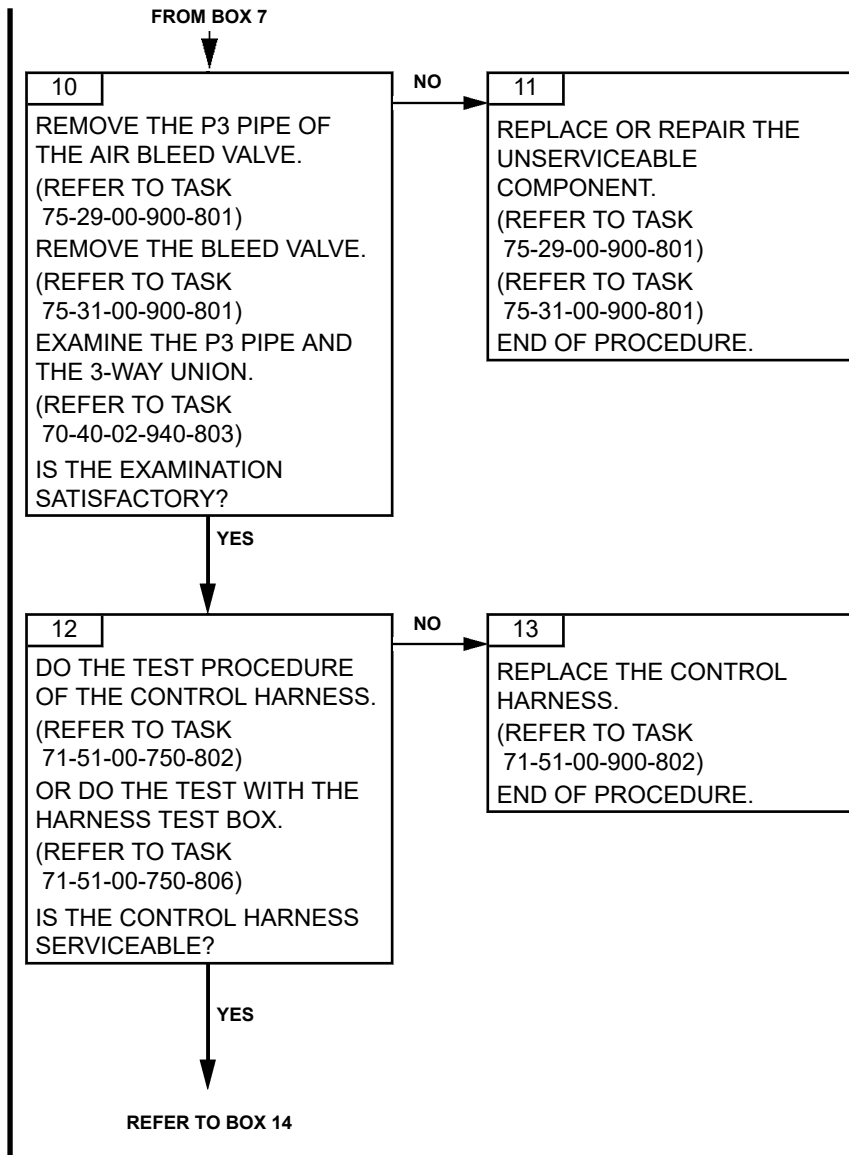

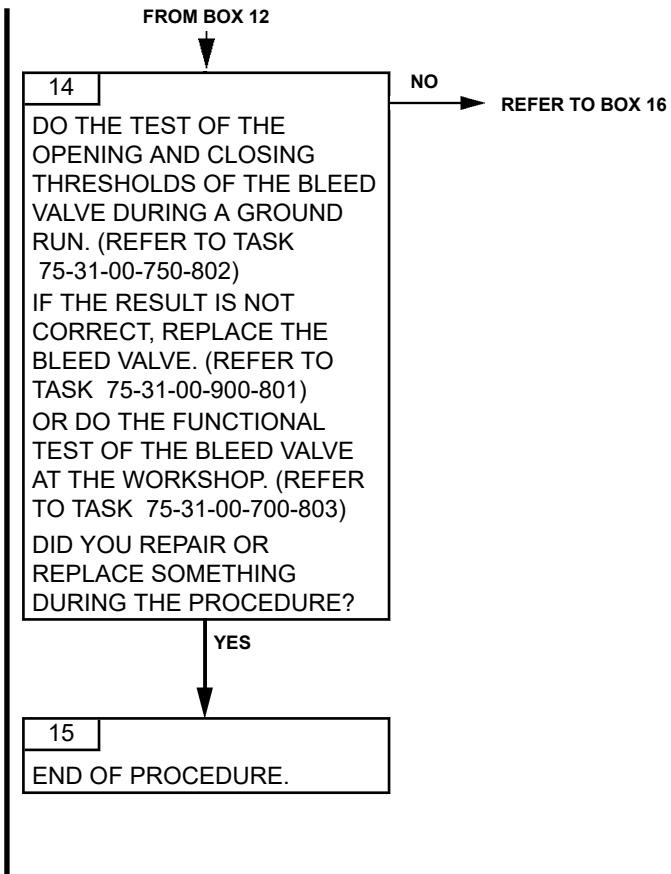

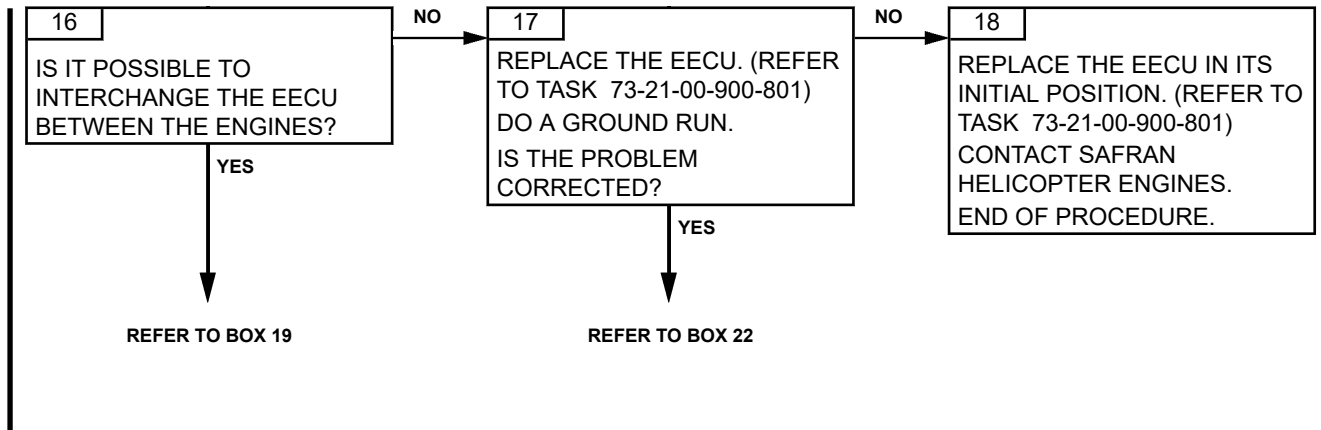

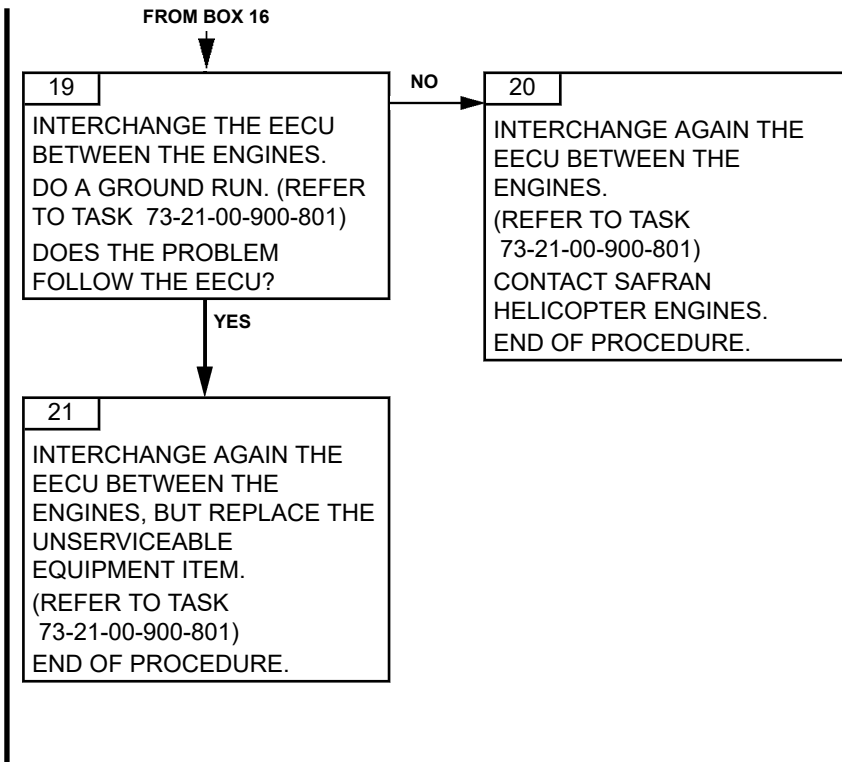

ARRIEL 2 C1

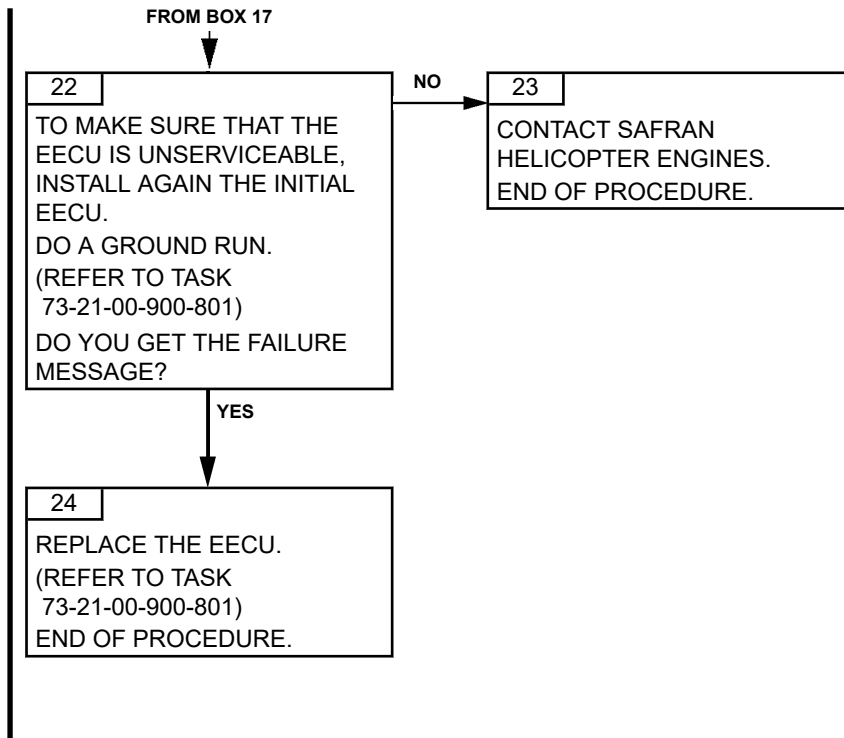

PAGE LEFT BLANK INTENTIONALLY

TASK 71-00-06-817-889-A01

**HELICOPTER T4.5 FAILURE
TROUBLESHOOTING****1. GENERAL****A. VEMD FAILURE MESSAGE**

<i>VEMD MESSAGE</i>
H TOT. A

The helicopter T4.5 is sent to the EECU through the ARINC link label 132.

This message shows that the EECU operates correctly: an incorrect communication between the aircraft and the EECU can cause a "H. LINK A" or ARINC failure message.

B. FAILURE EFFECTS

<i>EFFECTS</i>	<i>CAD MESSAGE</i>
Impossible to use the helicopter T45 as backup valve. No effect on the engine operation.	flashing GOV

CAUTION: MAKE SURE THAT THE CONCERNED AIRCRAFT SYSTEM IS SERVICEABLE BEFORE YOU SWAP THE ENGINE ELECTRONIC CONTROL UNITS.

CAUTION: WHEN CHECKING THE "FAIL" LINE ON THE VEMD SYSTEM STATUS PAGE, MAKE SURE TO CHECK ALL FAILURES. TO DO SO, PRESS THE SELECT KEY UNTIL A WHITE FRAME SURROUNDS THE "FAIL" LINE. THEN, USE "+/-" KEY TO VIEW ALL FAILURES. PROCEED THE SAME WAY TO CHECK ALL MESSAGES ON THE "MSG" LINE.

CAUTION: THE FAILURE INFORMATION ON THE VEMD SYSTEM STATUS PAGE MAY NO LONGER BE AVAILABLE AFTER BATTERY POWER IS TURNED OFF. THEREFORE, AFTER A FAILURE OCCURRED, IT IS VERY IMPORTANT TO CHECK AND WRITE DOWN ALL INFORMATION FROM THE "FAIL" LINE AND THE "MSG" LINE BEFORE TURNING BATTERY POWER OFF.

C. POSSIBLE CAUSES

- Junction and T4.5 conformation box
- Pyrometric harness
- Control and monitoring harness
- Aircraft wiring from P100 to T4.5 indication (Aircraft system)

2. PROCEDURE

Effectivity: C1

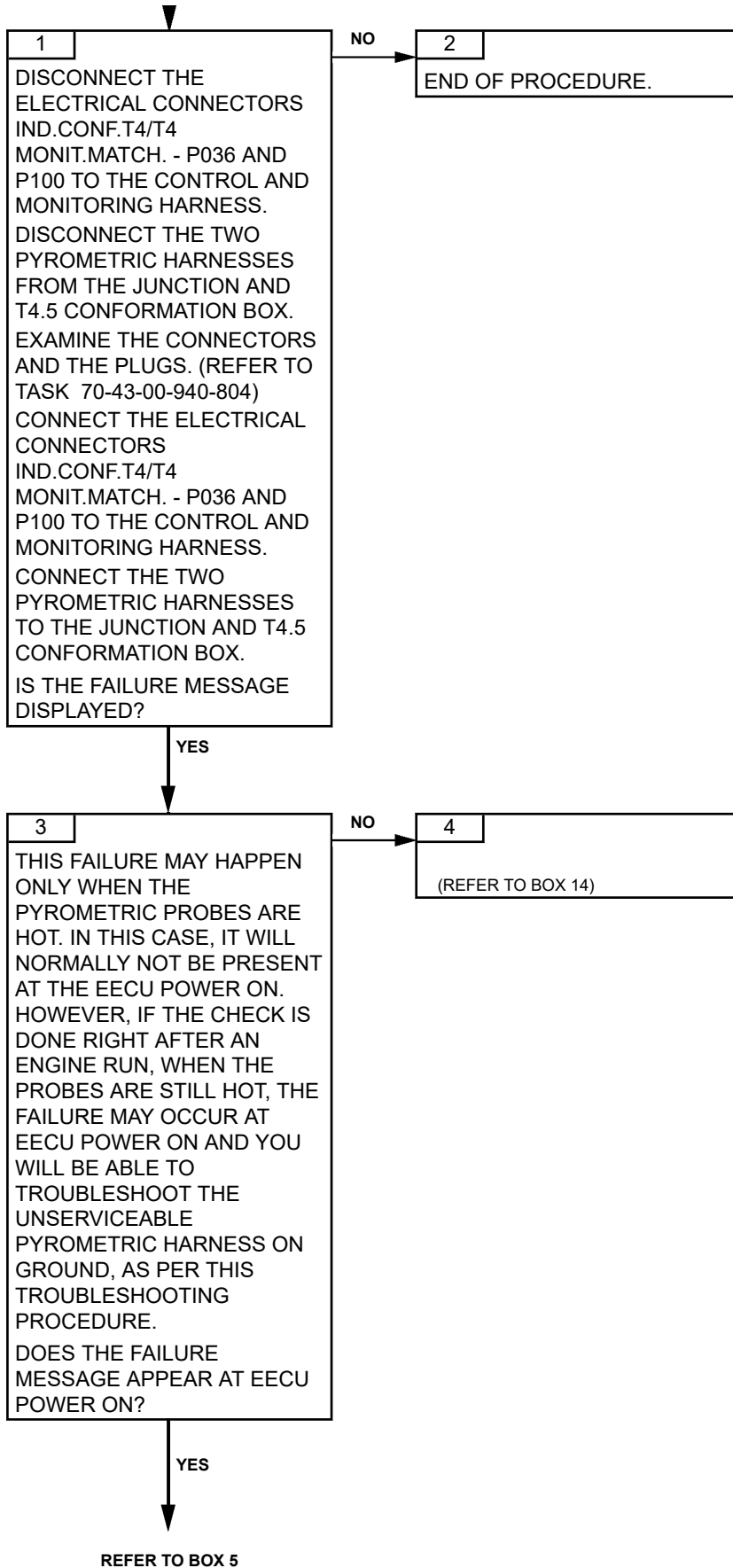

Effectivity: C1

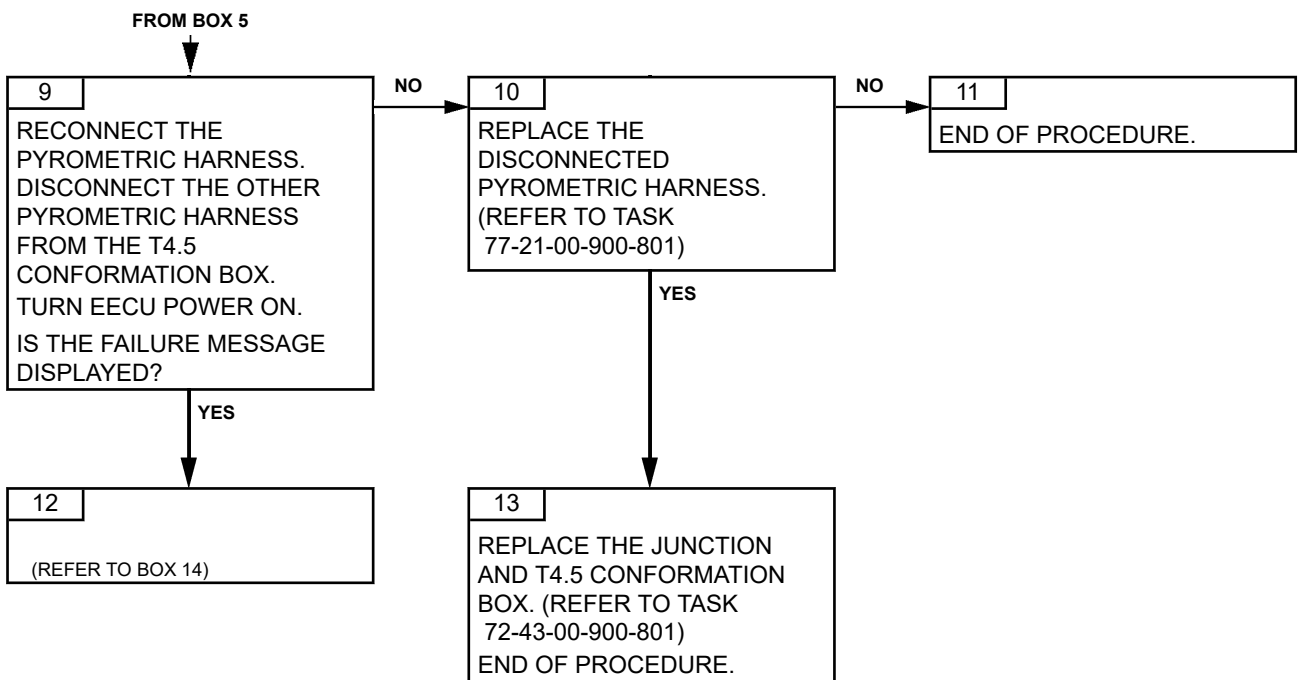
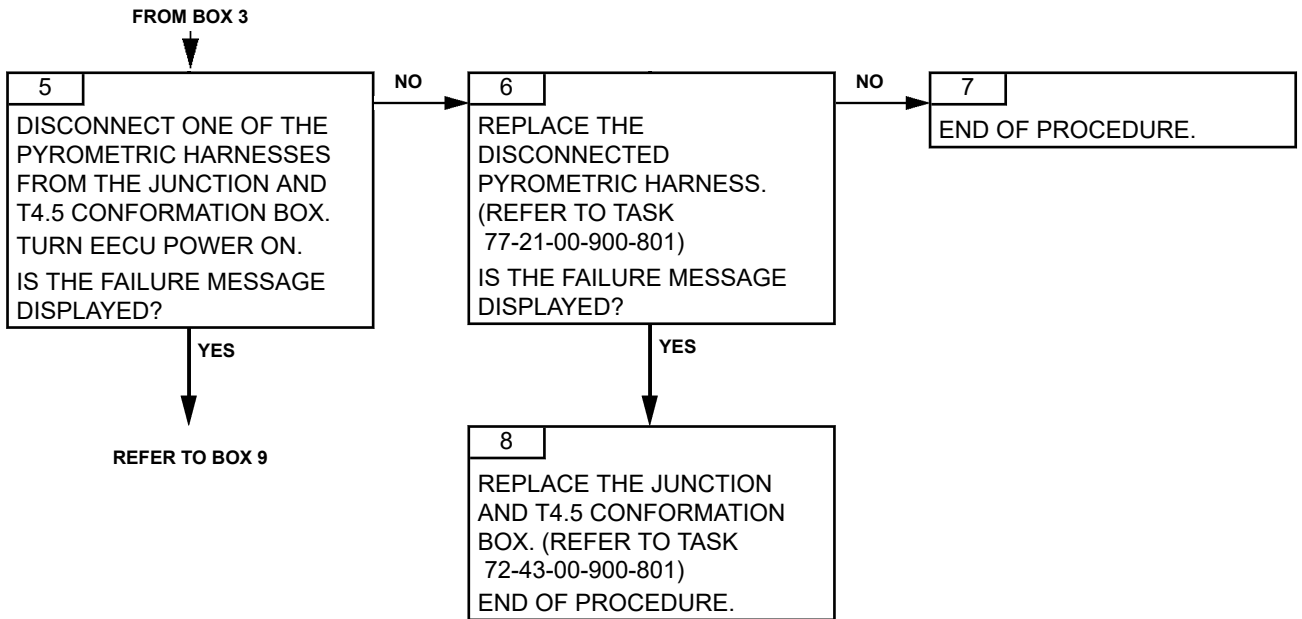

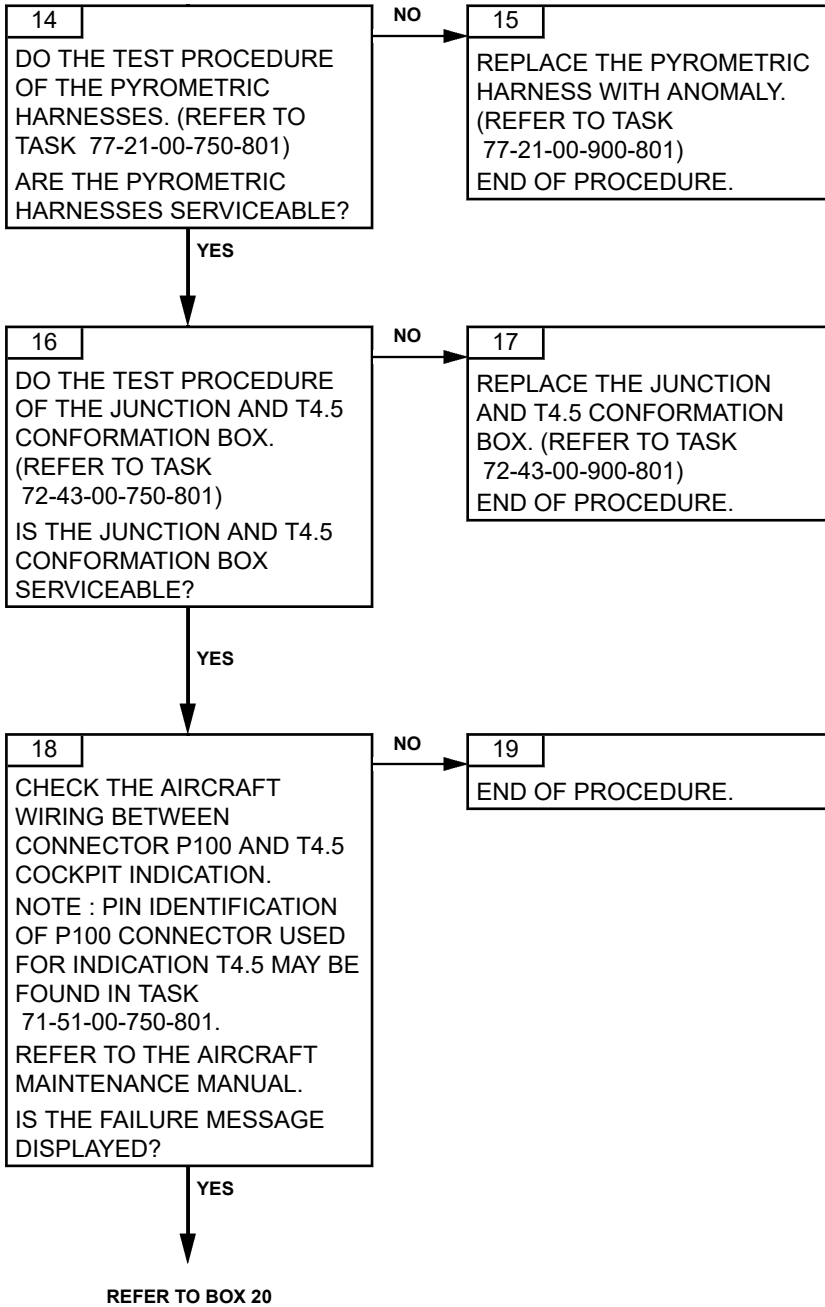

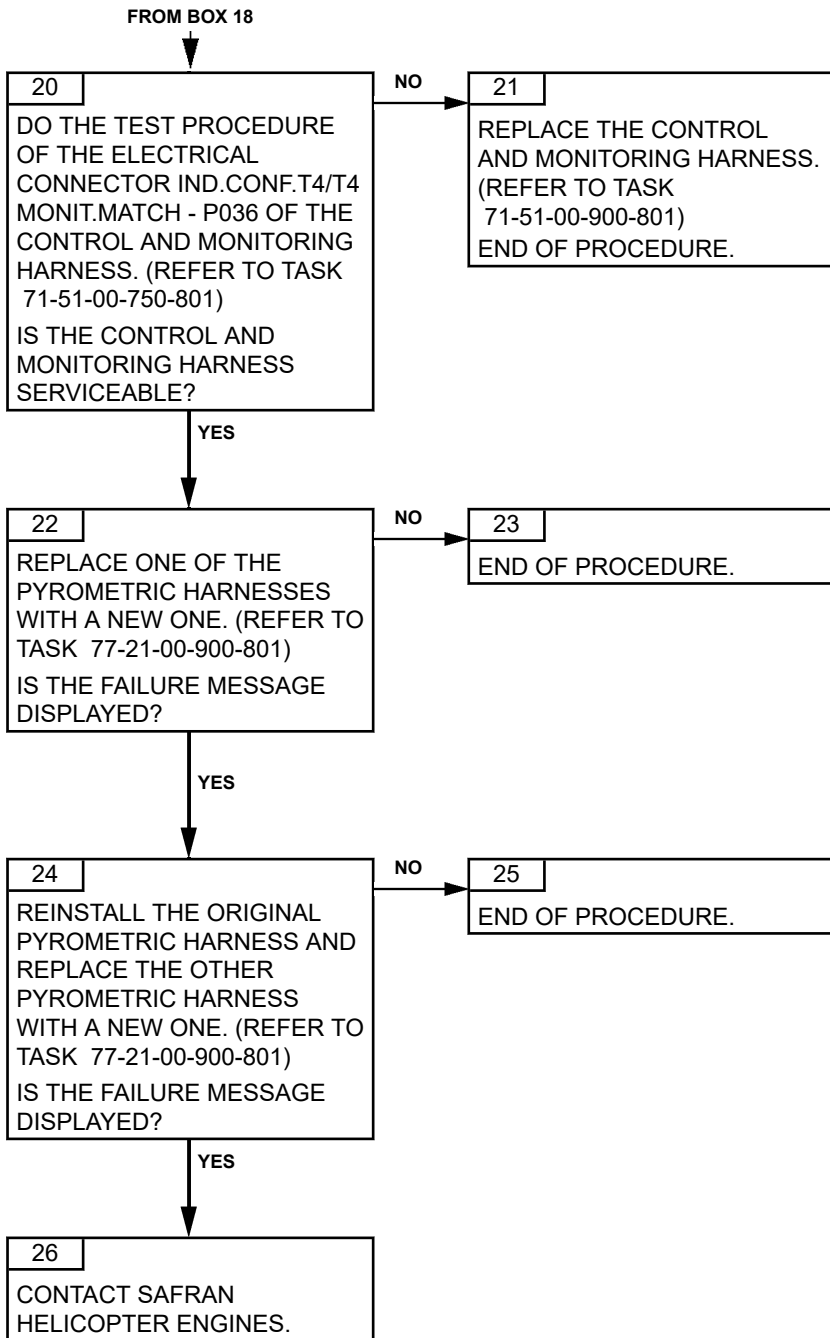

PAGE LEFT BLANK INTENTIONALLY

TASK 71-00-06-817-890-A01

**CROSS TALK ARINC
TROUBLESHOOTING****1. GENERAL****A. VEMD FAILURE MESSAGE**

VEMD MESSAGE
BALANC. A

B. FAILURE EFFECTS

EFFECTS	CAD MESSAGE
N2 regulation in proportional mode (loss of NR revolution). Both EECUs display simultaneously the failure message. Accuracy of N2 is degraded.	GOV

NOTE: *This failure is reversible if the engine is in OFF, START or IDLE mode (meaning that if the fault condition disappears, the fault message and effect will also disappear). In FLIGHT mode, the failure is not reversible.*

CAUTION: MAKE SURE THAT THE CONCERNED AIRCRAFT SYSTEM IS SERVICEABLE BEFORE YOU SWAP THE ENGINE ELECTRONIC CONTROL UNITS.

CAUTION: WHEN CHECKING THE “FAIL” LINE ON THE VEMD SYSTEM STATUS PAGE, MAKE SURE TO CHECK ALL FAILURES. TO DO SO, PRESS THE SELECT KEY UNTIL A WHITE FRAME SURROUNDS THE “FAIL” LINE. THEN, USE “+/-” KEY TO VIEW ALL FAILURES. PROCEED THE SAME WAY TO CHECK ALL MESSAGES ON THE “MSG” LINE.

CAUTION: THE FAILURE INFORMATION ON THE VEMD SYSTEM STATUS PAGE MAY NO LONGER BE AVAILABLE AFTER BATTERY POWER IS TURNED OFF. THEREFORE, AFTER A FAILURE OCCURRED, IT IS VERY IMPORTANT TO CHECK AND WRITE DOWN ALL INFORMATION FROM THE “FAIL” LINE AND THE “MSG” LINE BEFORE TURNING BATTERY POWER OFF.

C. POSSIBLE CAUSES

- EECU
- EECU cross link function (Aircraft system)

2. PROCEDURE

NOTE: *Cross-talk connection from connector P2 EECU 1 to connector P2 EECU 2:
ARINC transmission:*

- Pin 6 EECU 1 connects to pin 8 EECU 2
- Pin 2 EECU 1 connects to pin 9 EECU 2.

ARINC reception:

Effectivity: C1

- Pin 8 EECU 1 connects to pin 6 EECU 2
- Pin 9 EECU 1 connects to pin 2 EECU 2

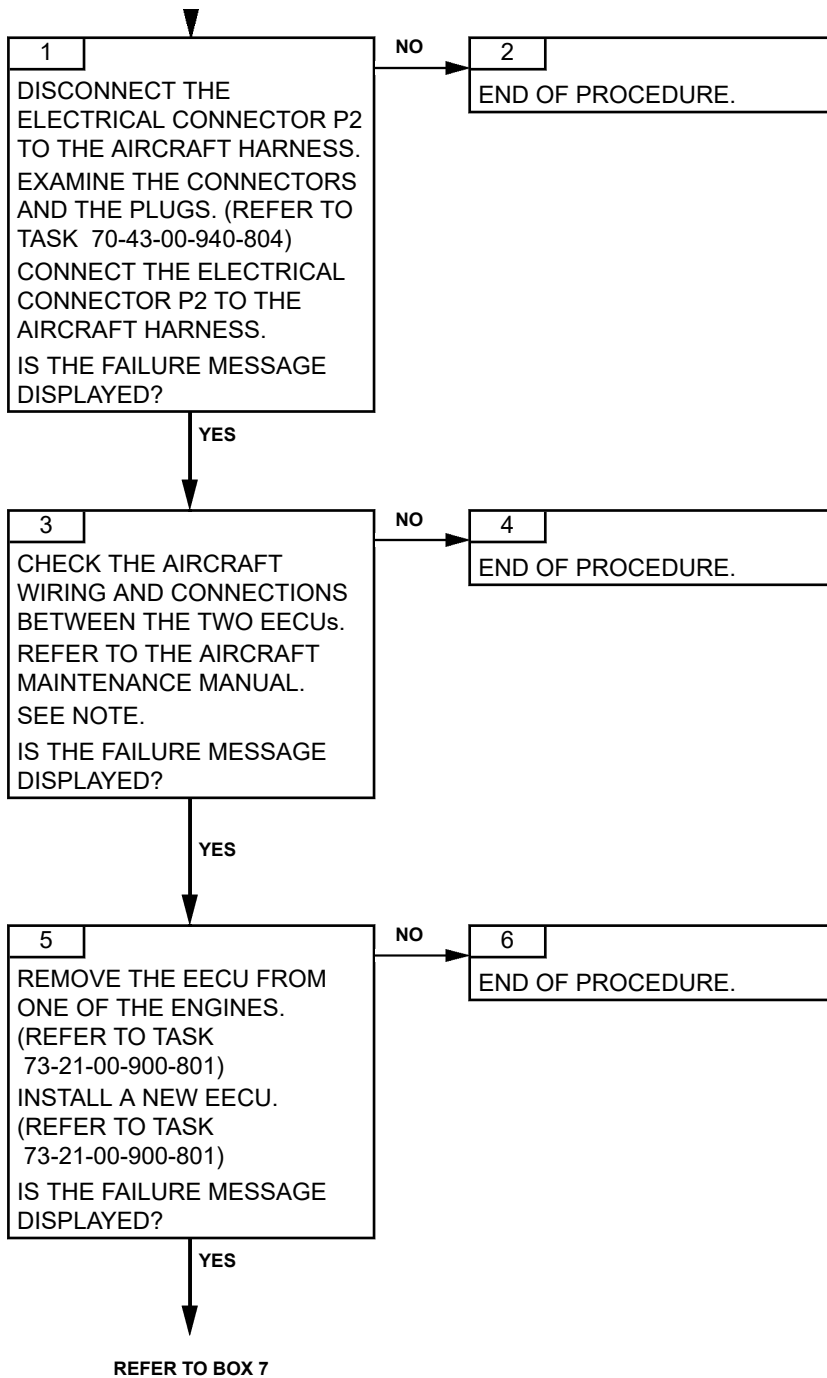

ARRIEL 2 C1

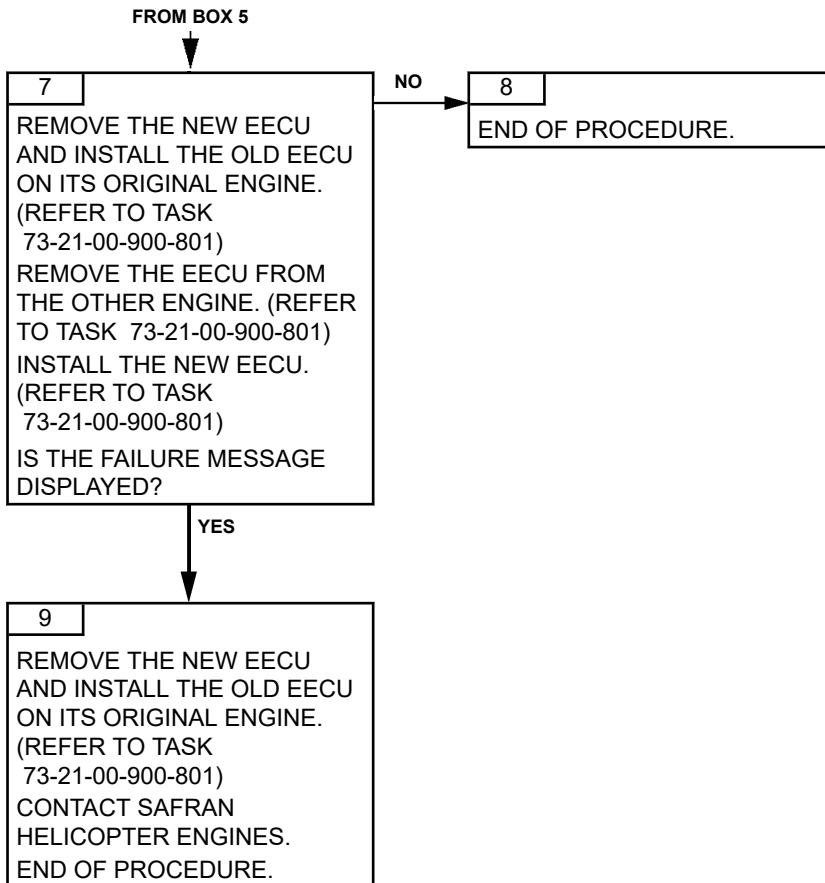

PAGE LEFT BLANK INTENTIONALLY

TASK 71-00-06-817-905-A01

NR FAILURE TROUBLESHOOTING

1. GENERAL

A. VEMD MESSAGE

<i>VEMD MESSAGE</i>
NR. A

<i>EFFECT</i>	<i>GOV</i>
Inhibition of the power loss detection.	Flashing amber

CAUTION: MAKE SURE THAT THE CONCERNED AIRCRAFT SYSTEM IS SERVICEABLE BEFORE YOU SWAP THE ENGINE ELECTRONIC CONTROL UNITS.

B. POSSIBLE CAUSES

- DECU

2. PROCEDURE

Effectivity: C1

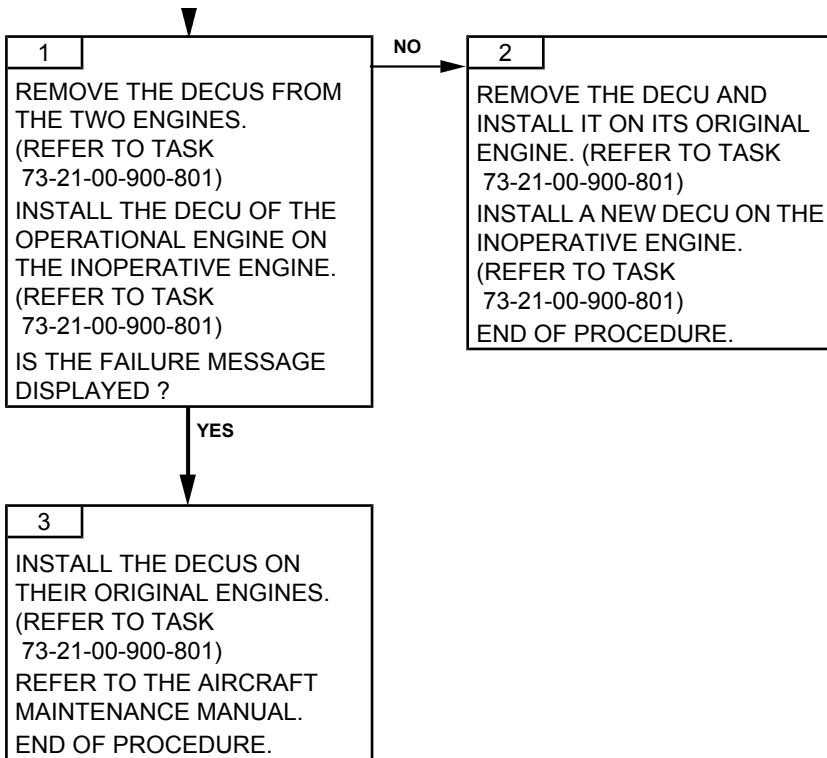

TASK 71-00-06-817-906-A01

DECU CONFIGURATION/AIRCRAFT CONFIGURATION INCONSISTENCY TROUBLESHOOTING

1. GENERAL

A. VEMD FAILURE MESSAGE

<i>VEMD MESSAGE</i>
VERSION. A or VERSION. B

B. FAILURE EFFECTS

<i>EFFECTS</i>	<i>CAD MESSAGE</i>
If VERSION. A only or if VERSION. A + VERSION. B – The helicopter configuration received via the ARINC message is not recognized by the EECU. Display of degraded operation.	GOV
If VERSION. B only – No effect.	flashing GOV

CAUTION: WHEN CHECKING THE “FAIL” LINE ON THE VEMD SYSTEM STATUS PAGE, MAKE SURE TO CHECK ALL FAILURES. TO DO SO, PRESS THE SELECT KEY UNTIL A WHITE FRAME SURROUNDS THE “FAIL” LINE. THEN, USE “+/-” KEY TO VIEW ALL FAILURES. PROCEED THE SAME WAY TO CHECK ALL MESSAGES ON THE “MSG” LINE.

CAUTION: THE FAILURE INFORMATION ON THE VEMD SYSTEM STATUS PAGE MAY NO LONGER BE AVAILABLE AFTER BATTERY POWER IS TURNED OFF. THEREFORE, AFTER A FAILURE OCCURRED, IT IS VERY IMPORTANT TO CHECK AND WRITE DOWN ALL INFORMATION FROM THE “FAIL” LINE AND THE “MSG” LINE BEFORE TURNING BATTERY POWER OFF.

C. POSSIBLE CAUSES

- EECU

This failure message means that the incorrect EECU is installed on the airframe.

2. PROCEDURE

Effectivity: C1



1

DO THE CHECK OF THE
EECU PART NUMBER
BETWEEN THE
IDENTIFICATION PLATE AND
THE EECU LOG CARD.

TASK 71-00-06-817-907-A01

N2 FAILURE (B ON THE HARNESS) TROUBLESHOOTING

1. GENERAL

A. VEMD FAILURE MESSAGE

<i>VEMD MESSAGE</i>
NF. B

B. FAILURE EFFECTS

<i>EFFECTS</i>	<i>CAD MESSAGE</i>
Total failure of channel B – If channel A in control: no effect – If channel B in control after total failure of channel A: stepper motor freezing.	flashing GOV FADEC

CAUTION: MAKE SURE THAT THE CONCERNED AIRCRAFT SYSTEM IS SERVICEABLE BEFORE YOU SWAP THE ENGINE ELECTRONIC CONTROL UNITS.

CAUTION: THE EECU CAN DETECT THIS FAILURE IF THE DIFFERENCE BETWEEN THE 2 SIGNALS IS GREATER THAN 3%. IF EACH N2 SIGNAL IS WITHIN ACCEPTABLE VALUES, THE EECU MAY NOT FIND THE ACCURATE CAUSE OF THE FAILURE AND DECLARE THE LOSS OF THE TWO N2 SPEED SENSORS INFORMATION (FOR CHANNEL A AND CHANNEL B), LEADING TO A STEPPER MOTOR FREEZING.

CAUTION: IN CASE OF N2 DOUBLE FAILURE. IF AT THE NEXT POWER ON THE MESSAGES “NF. A” AND “NF. B” ARE NOT DISPLAYED, THERE IS STILL A HIGH CHANCE FOR ONE OF THE TWO SENSORS TO FAIL DURING THE ENGINE RUN. DO THE TROUBLESHOOTING TASK PROCEDURE.

CAUTION: WHEN CHECKING THE “FAIL” LINE ON THE VEMD SYSTEM STATUS PAGE, MAKE SURE TO CHECK ALL FAILURES. TO DO SO, PRESS THE SELECT KEY UNTIL A WHITE FRAME SURROUNDS THE “FAIL” LINE. THEN, USE “+/-” KEY TO VIEW ALL FAILURES. PROCEED THE SAME WAY TO CHECK ALL MESSAGES ON THE “MSG” LINE.

CAUTION: THE FAILURE INFORMATION ON THE VEMD SYSTEM STATUS PAGE MAY NO LONGER BE AVAILABLE AFTER BATTERY POWER IS TURNED OFF. THEREFORE, AFTER A FAILURE OCCURRED, IT IS VERY IMPORTANT TO CHECK AND WRITE DOWN ALL INFORMATION FROM THE “FAIL” LINE AND THE “MSG” LINE BEFORE TURNING BATTERY POWER OFF.

C. POSSIBLE CAUSES

- N2B speed sensor
- EECU
- Control harness

Effectivity: C1

2. PROCEDURE

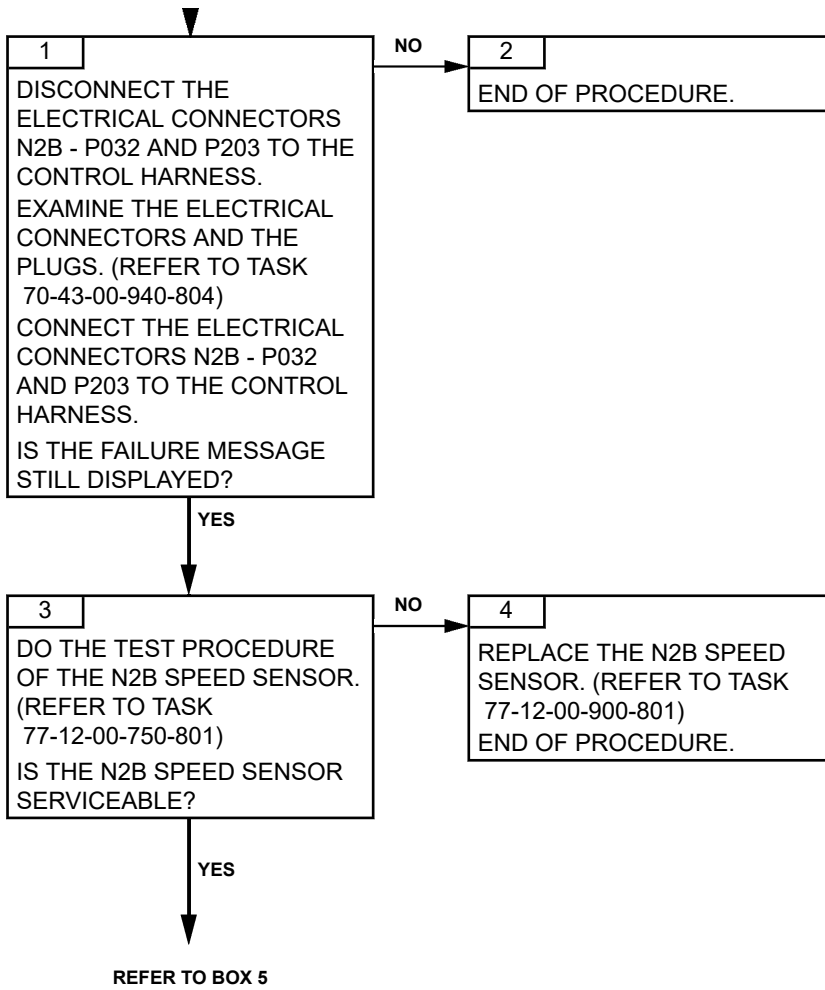

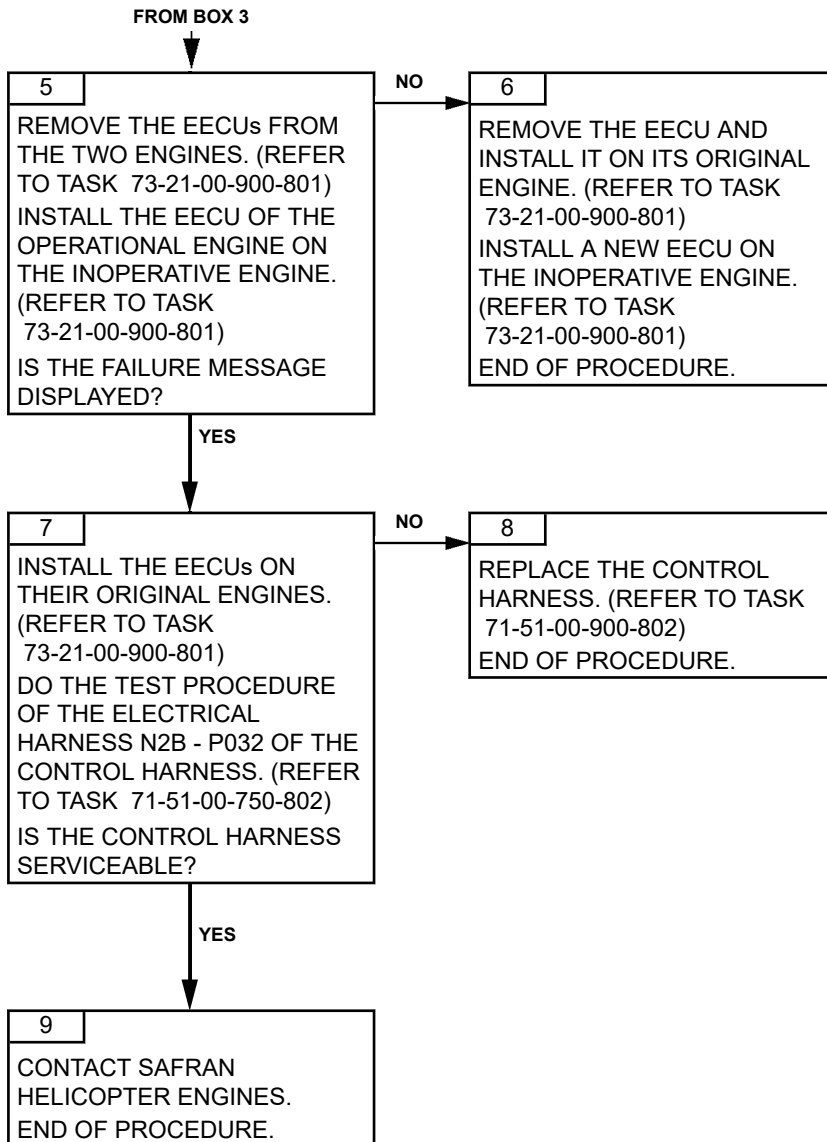

ARRIEL 2 C1

TASK 71-00-06-817-910-A01

**INTERCHANNEL RECEPTION FAILURE
TROUBLESHOOTING****1. GENERAL****A. VEMD FAILURE MESSAGE**

<i>VEMD MESSAGE</i>
A/B RE. A or A/B RE. B

B. FAILURE EFFECTS

<i>EFFECTS</i>	<i>CAD MESSAGE</i>
If A/B RE. A – No effect.	flashing GOV
If A/B RE. B – If channel A in control: no effect – If channel B in control following a channel A total failure: degraded engine performance. Loss of cross talk ARINC message. N2 in proportional mode (Loss of NR revolution, NR accuracy degraded).	flashing GOV GOV

CAUTION: MAKE SURE THAT THE CONCERNED AIRCRAFT SYSTEM IS SERVICEABLE BEFORE YOU SWAP THE ENGINE ELECTRONIC CONTROL UNITS.

CAUTION: WHEN CHECKING THE “FAIL” LINE ON THE VEMD SYSTEM STATUS PAGE, MAKE SURE TO CHECK ALL FAILURES. TO DO SO, PRESS THE SELECT KEY UNTIL A WHITE FRAME SURROUNDS THE “FAIL” LINE. THEN, USE “+/-” KEY TO VIEW ALL FAILURES. PROCEED THE SAME WAY TO CHECK ALL MESSAGES ON THE “MSG” LINE.

CAUTION: THE FAILURE INFORMATION ON THE VEMD SYSTEM STATUS PAGE MAY NO LONGER BE AVAILABLE AFTER BATTERY POWER IS TURNED OFF. THEREFORE, AFTER A FAILURE OCCURRED, IT IS VERY IMPORTANT TO CHECK AND WRITE DOWN ALL INFORMATION FROM THE “FAIL” LINE AND THE “MSG” LINE BEFORE TURNING BATTERY POWER OFF.

C. POSSIBLE CAUSES

- EECU

2. PROCEDURE

Effectivity: C1

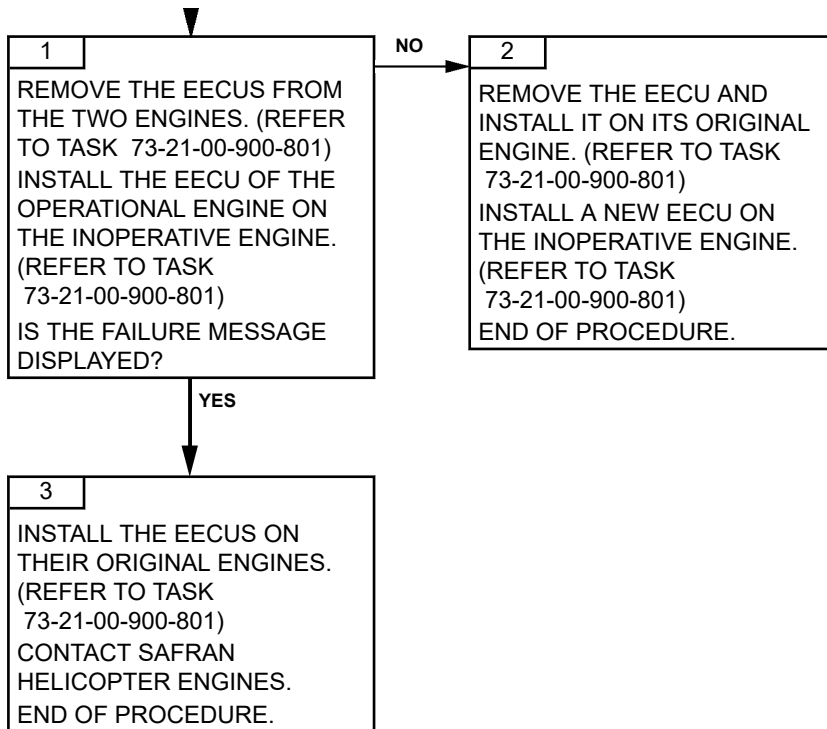

TASK 71-00-06-817-913-A01

N2 FAILURE (C ON THE HARNESS) TROUBLESHOOTING

1. GENERAL

A. VEMD FAILURE MESSAGE

VEMD MESSAGE
NF. A

B. FAILURE EFFECTS

EFFECTS	CAD MESSAGE
Total failure of channel A	flashing GOV FADEC
– If non total failure of channel B: automatic reversion to channel B. No effect	
– If total failure of channel B: stepper motor freezing.	

NOTE: If NF. A present at EECU power ON, PROCES. A, SELECT. B, T/SEL. B may also appear. Do the troubleshooting procedure of NF. A first.

CAUTION: MAKE SURE THAT THE CONCERNED AIRCRAFT SYSTEM IS SERVICEABLE BEFORE YOU SWAP THE ENGINE ELECTRONIC CONTROL UNITS.

CAUTION: THE EECU CAN DETECT THIS FAILURE IF THE DIFFERENCE BETWEEN THE 2 SIGNALS IS GREATER THAN 3%. IF EACH N2 SIGNAL IS WITHIN ACCEPTABLE VALUES, THE EECU MAY NOT FIND THE ACCURATE CAUSE OF THE FAILURE AND DECLARE THE LOSS OF THE TWO N2 SPEED SENSORS INFORMATION (FOR CHANNEL A AND CHANNEL B), LEADING TO A STEPPER MOTOR FREEZING.

CAUTION: IN CASE OF N2 DOUBLE FAILURE. IF AT THE NEXT POWER ON THE MESSAGES “NF. A” AND “NF. B” ARE NOT DISPLAYED, THERE IS STILL A HIGH CHANCE FOR ONE OF THE TWO SENSORS TO FAIL DURING THE ENGINE RUN. DO THE TROUBLESHOOTING TASK PROCEDURE.

CAUTION: WHEN CHECKING THE “FAIL” LINE ON THE VEMD SYSTEM STATUS PAGE, MAKE SURE TO CHECK ALL FAILURES. TO DO SO, PRESS THE SELECT KEY UNTIL A WHITE FRAME SURROUNDS THE “FAIL” LINE. THEN, USE “+/-” KEY TO VIEW ALL FAILURES. PROCEED THE SAME WAY TO CHECK ALL MESSAGES ON THE “MSG” LINE.

CAUTION: THE FAILURE INFORMATION ON THE VEMD SYSTEM STATUS PAGE MAY NO LONGER BE AVAILABLE AFTER BATTERY POWER IS TURNED OFF. THEREFORE, AFTER A FAILURE OCCURRED, IT IS VERY IMPORTANT TO CHECK AND WRITE DOWN ALL INFORMATION FROM THE “FAIL” LINE AND THE “MSG” LINE BEFORE TURNING BATTERY POWER OFF.

C. POSSIBLE CAUSES

Effectivity: C1

- N2C speed sensor
- EECU
- Control harness

2. PROCEDURE

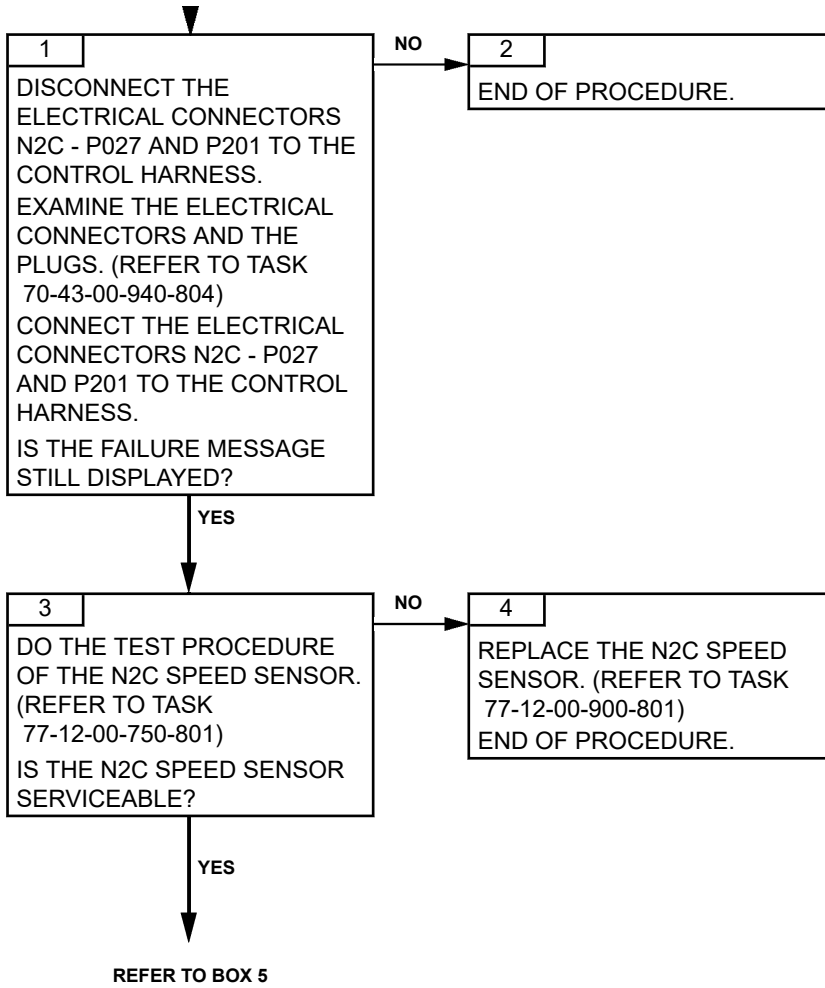

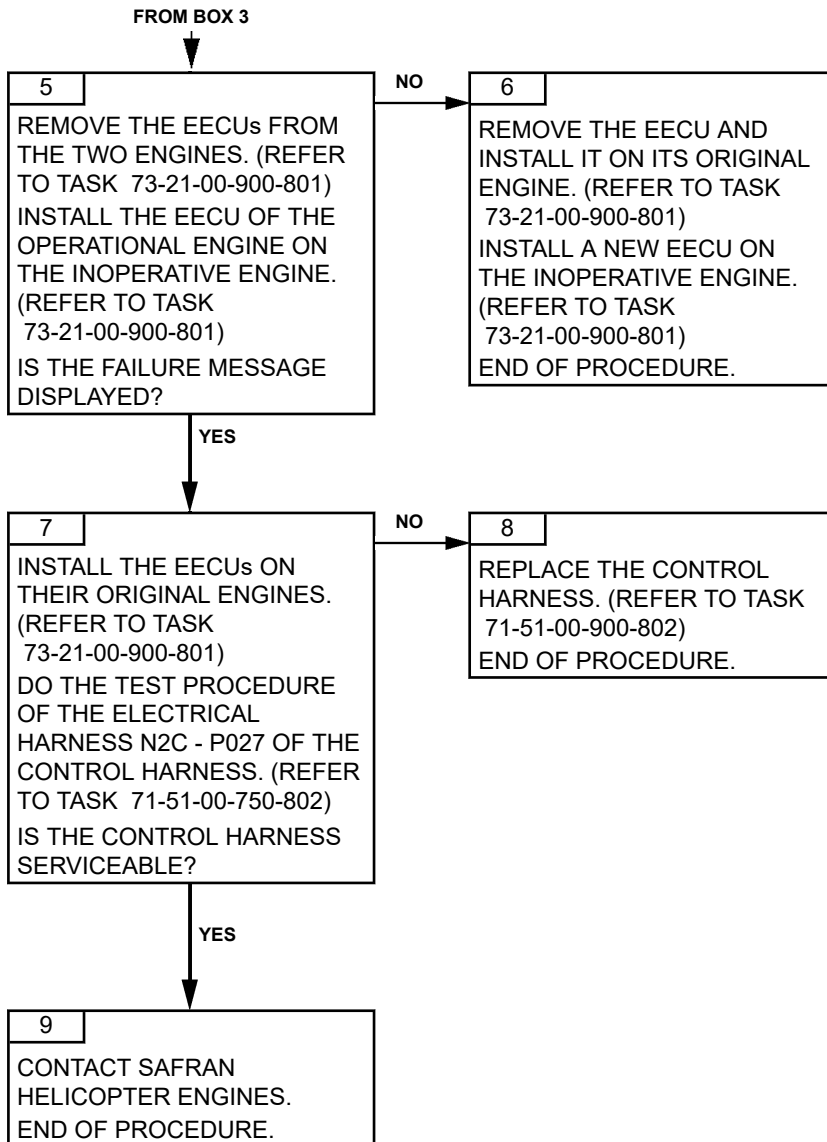

TASK 71-00-06-817-918-A01

**N1 FAILURE (A ALTERNATOR ON THE HARNESS)
TROUBLESHOOTING****1. GENERAL****A. VEMD FAILURE MESSAGE**

<i>VEMD MESSAGE</i>
NG. A

B. FAILURE EFFECTS

<i>EFFECTS</i>	<i>CAD MESSAGE</i>
Total failure of channel A. Automatic reversion to channel B.	flashing GOV

CAUTION: MAKE SURE THAT THE CONCERNED AIRCRAFT SYSTEM IS SERVICEABLE BEFORE YOU SWAP THE ENGINE ELECTRONIC CONTROL UNITS.

CAUTION: WHEN CHECKING THE “FAIL” LINE ON THE VEMD SYSTEM STATUS PAGE, MAKE SURE TO CHECK ALL FAILURES. TO DO SO, PRESS THE SELECT KEY UNTIL A WHITE FRAME SURROUNDS THE “FAIL” LINE. THEN, USE “+/-” KEY TO VIEW ALL FAILURES. PROCEED THE SAME WAY TO CHECK ALL MESSAGES ON THE “MSG” LINE.

CAUTION: THE FAILURE INFORMATION ON THE VEMD SYSTEM STATUS PAGE MAY NO LONGER BE AVAILABLE AFTER BATTERY POWER IS TURNED OFF. THEREFORE, AFTER A FAILURE OCCURRED, IT IS VERY IMPORTANT TO CHECK AND WRITE DOWN ALL INFORMATION FROM THE “FAIL” LINE AND THE “MSG” LINE BEFORE TURNING BATTERY POWER OFF.

C. POSSIBLE CAUSES

- Alternator
- EECU
- Control harness
- Module 01 Accessory gearbox and transmission shaft

2. PROCEDURE

Effectivity: C1

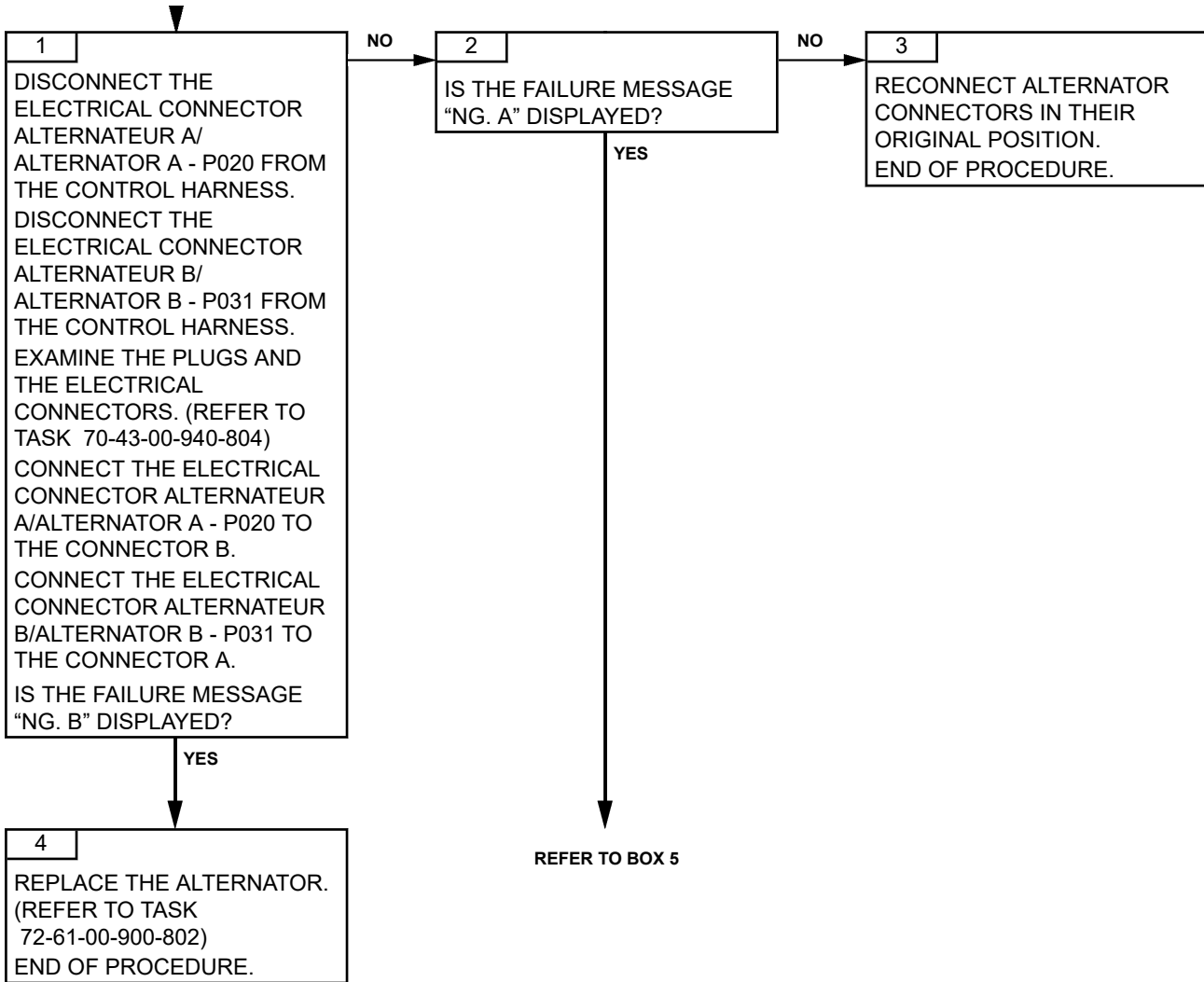

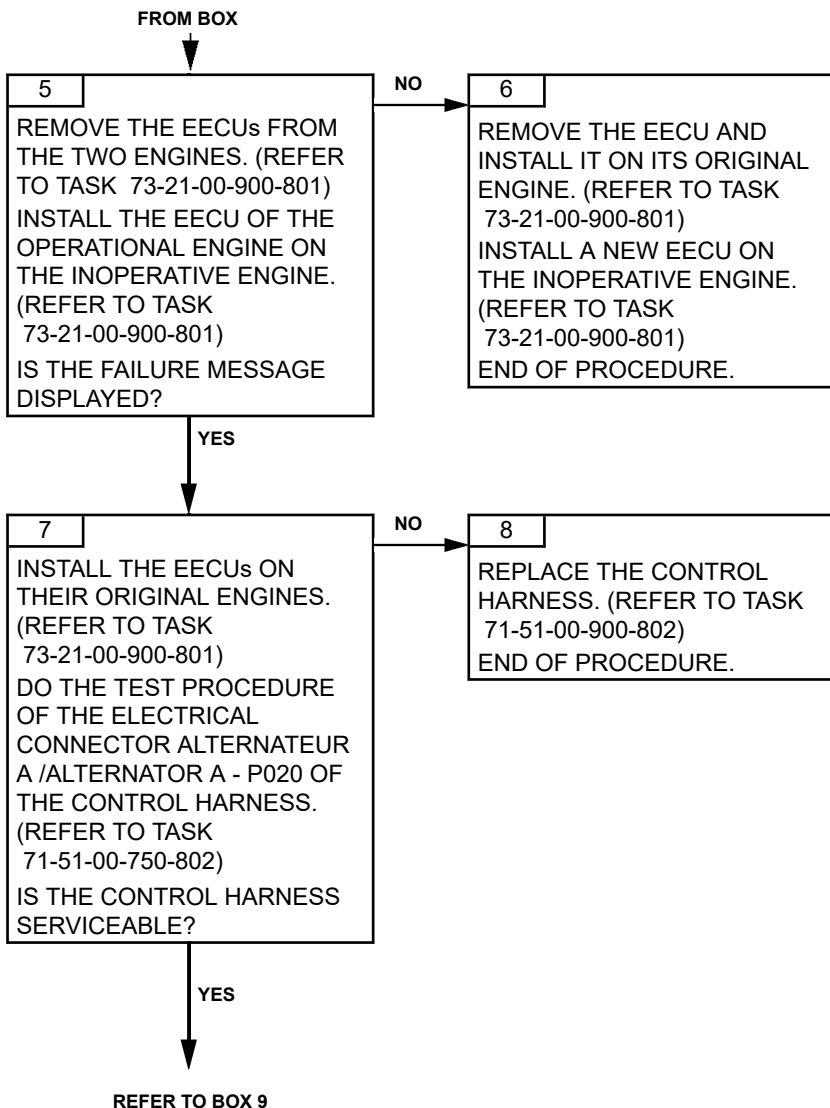

FROM BOX 7

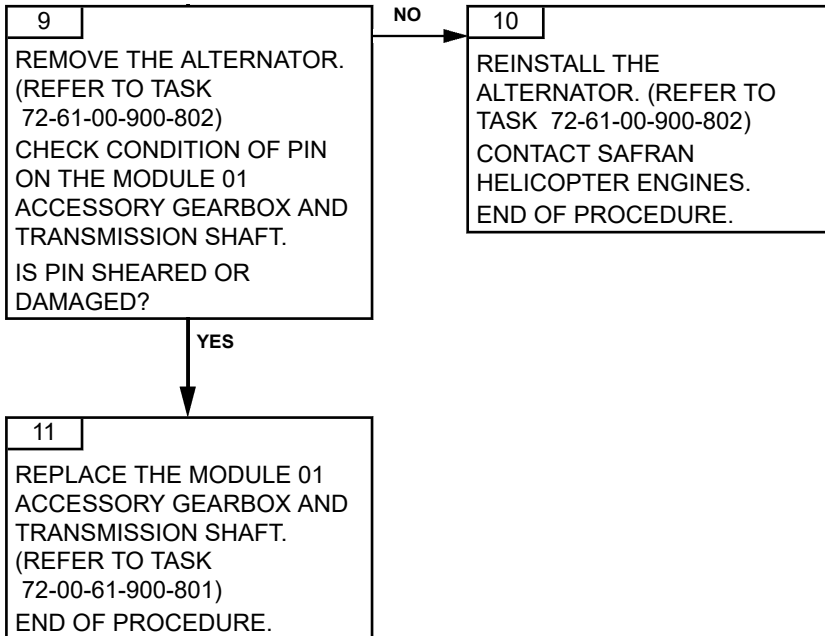

TASK 71-00-06-817-919-A01

**N1 FAILURE (B ALTERNATOR ON THE HARNESS)
TROUBLESHOOTING****1. GENERAL****A. VEMD FAILURE MESSAGE**

<i>VEMD MESSAGE</i>
NG. B

B. FAILURE EFFECTS

<i>EFFECTS</i>	<i>CAD MESSAGE</i>
Total failure of channel B – If channel A in control: no effect – If channel B in control after total failure of channel A: stepper motor freezing.	flashing GOV FADEC

CAUTION: MAKE SURE THAT THE CONCERNED AIRCRAFT SYSTEM IS SERVICEABLE BEFORE YOU SWAP THE ENGINE ELECTRONIC CONTROL UNITS.

CAUTION: WHEN CHECKING THE “FAIL” LINE ON THE VEMD SYSTEM STATUS PAGE, MAKE SURE TO CHECK ALL FAILURES. TO DO SO, PRESS THE SELECT KEY UNTIL A WHITE FRAME SURROUNDS THE “FAIL” LINE. THEN, USE “+/-” KEY TO VIEW ALL FAILURES. PROCEED THE SAME WAY TO CHECK ALL MESSAGES ON THE “MSG” LINE.

CAUTION: THE FAILURE INFORMATION ON THE VEMD SYSTEM STATUS PAGE MAY NO LONGER BE AVAILABLE AFTER BATTERY POWER IS TURNED OFF. THEREFORE, AFTER A FAILURE OCCURRED, IT IS VERY IMPORTANT TO CHECK AND WRITE DOWN ALL INFORMATION FROM THE “FAIL” LINE AND THE “MSG” LINE BEFORE TURNING BATTERY POWER OFF.

C. POSSIBLE CAUSES

- Alternator
- EECU
- Control harness
- Module 01 Accessory gearbox and transmission shaft

2. PROCEDURE

Effectivity: C1

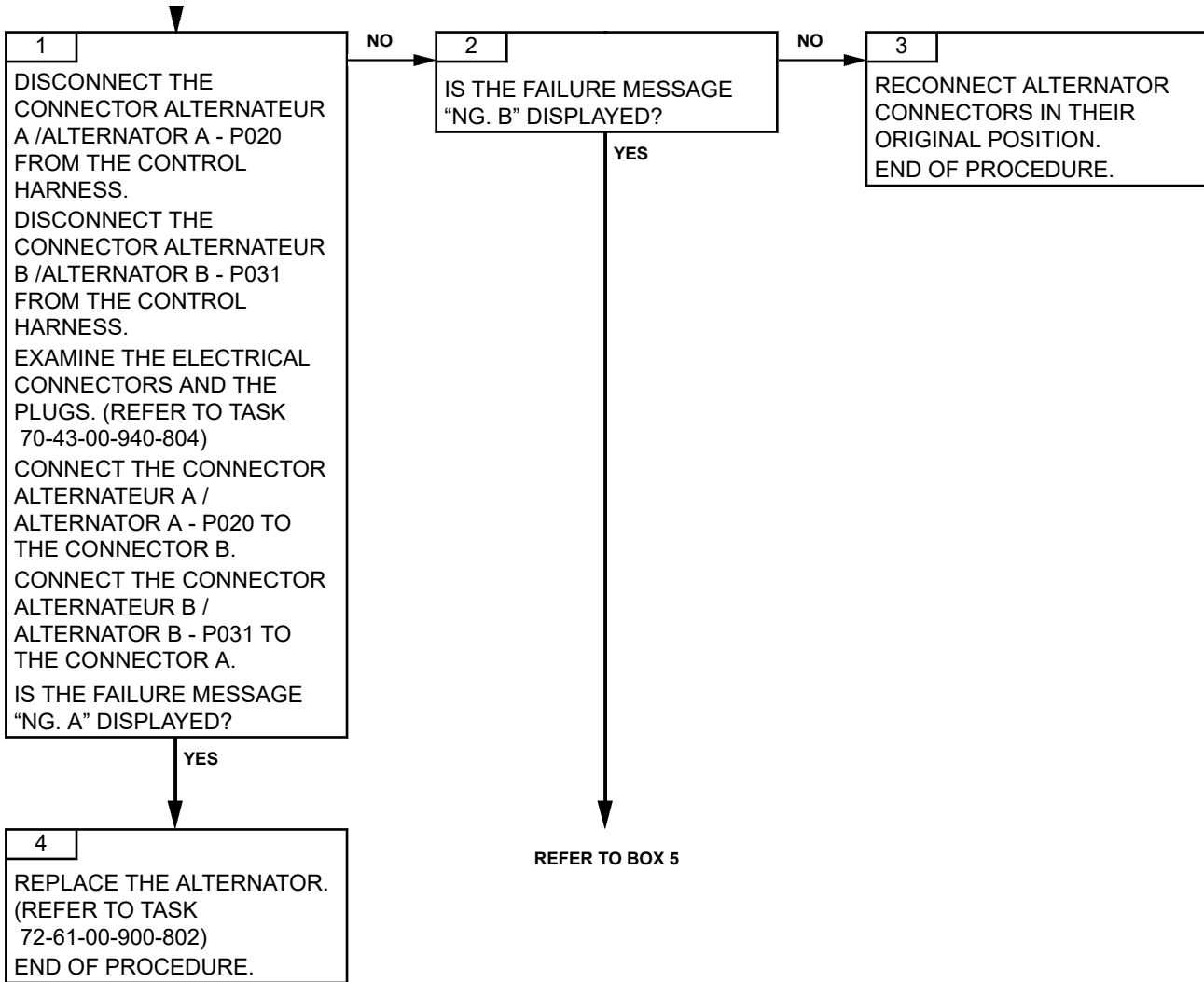

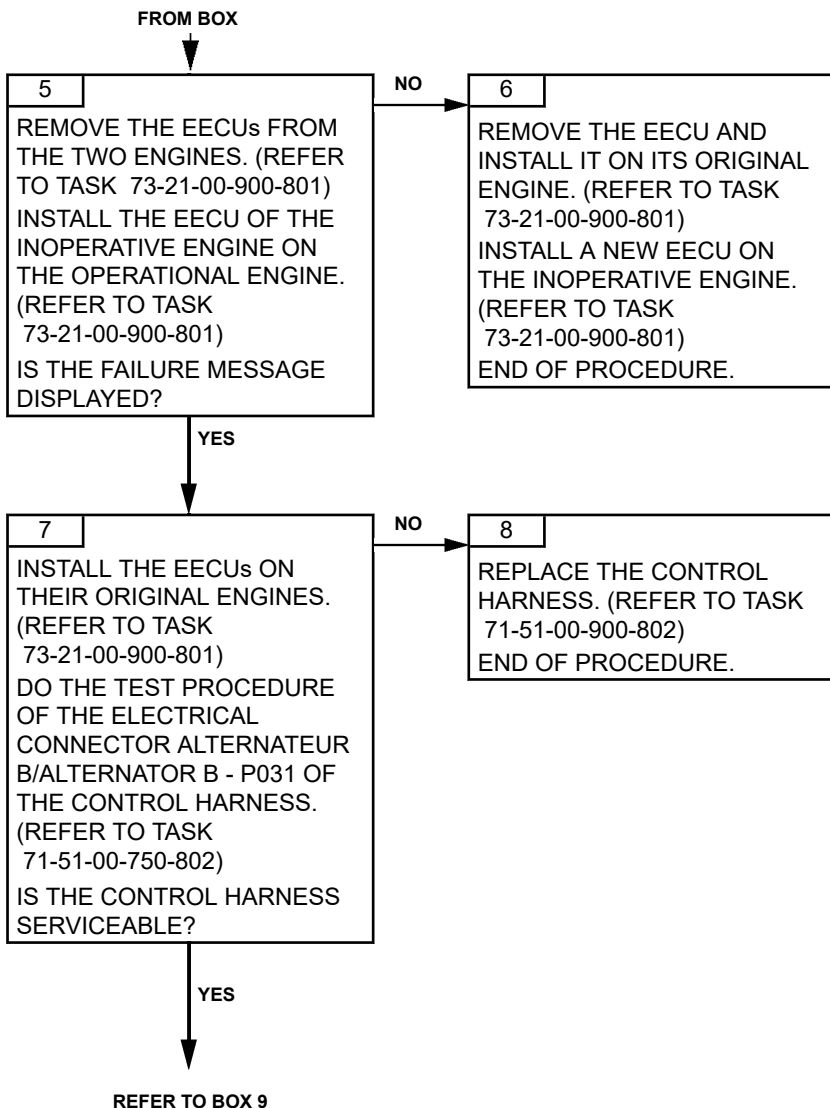

FROM BOX 7

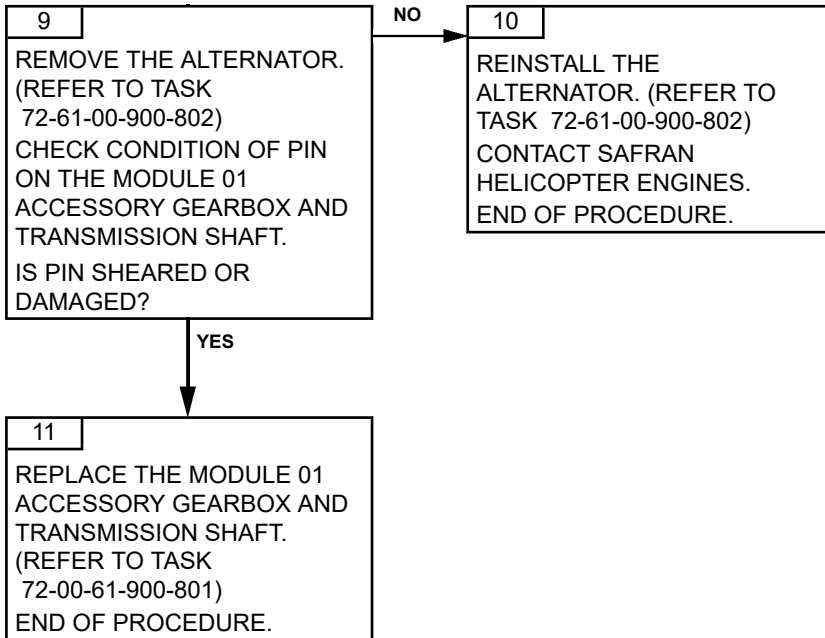

TASK 71-00-06-817-920-A01

N1 FAILURE ON THE ALTERNATOR ELECTRICAL CONNECTOR (A ALTERNATOR ON THE HARNESS AND B ALTERNATOR ON THE HARNESS) TROUBLESHOOTING

1. GENERAL

A. VEMD FAILURE MESSAGE

<i>VEMD MESSAGE</i>
NG. A and NG. B

B. FAILURE EFFECTS

<i>EFFECTS</i>	<i>CAD MESSAGE</i>
Total failure of channel A and B – Stepper motor freezing.	FADEC

CAUTION: MAKE SURE THAT THE CONCERNED AIRCRAFT SYSTEM IS SERVICEABLE BEFORE YOU SWAP THE ENGINE ELECTRONIC CONTROL UNITS.

CAUTION: THE EECU CAN DETECT THIS FAILURE IF THE DIFFERENCE BETWEEN THE 2 SIGNALS IS GREATER THAN 3%. IF EACH N1 SIGNAL IS WITHIN ACCEPTABLE VALUES, THE EECU MAY NOT FIND THE ACCURATE CAUSE OF THE FAILURE AND DECLARE THE LOSS OF THE TWO N1 SPEED SENSORS INFORMATION (FOR CHANNEL A AND CHANNEL B), LEADING TO A STEPPER MOTOR FREEZING.

CAUTION: WHEN CHECKING THE “FAIL” LINE ON THE VEMD SYSTEM STATUS PAGE, MAKE SURE TO CHECK ALL FAILURES. TO DO SO, PRESS THE SELECT KEY UNTIL A WHITE FRAME SURROUNDS THE “FAIL” LINE. THEN, USE “+/-” KEY TO VIEW ALL FAILURES. PROCEED THE SAME WAY TO CHECK ALL MESSAGES ON THE “MSG” LINE.

CAUTION: THE FAILURE INFORMATION ON THE VEMD SYSTEM STATUS PAGE MAY NO LONGER BE AVAILABLE AFTER BATTERY POWER IS TURNED OFF. THEREFORE, AFTER A FAILURE OCCURRED, IT IS VERY IMPORTANT TO CHECK AND WRITE DOWN ALL INFORMATION FROM THE “FAIL” LINE AND THE “MSG” LINE BEFORE TURNING BATTERY POWER OFF.

C. POSSIBLE CAUSES

- Alternator
- EECU
- Control harness.
- Module 01 Accessory gearbox and transmission shaft

2. PROCEDURE

Effectivity: C1

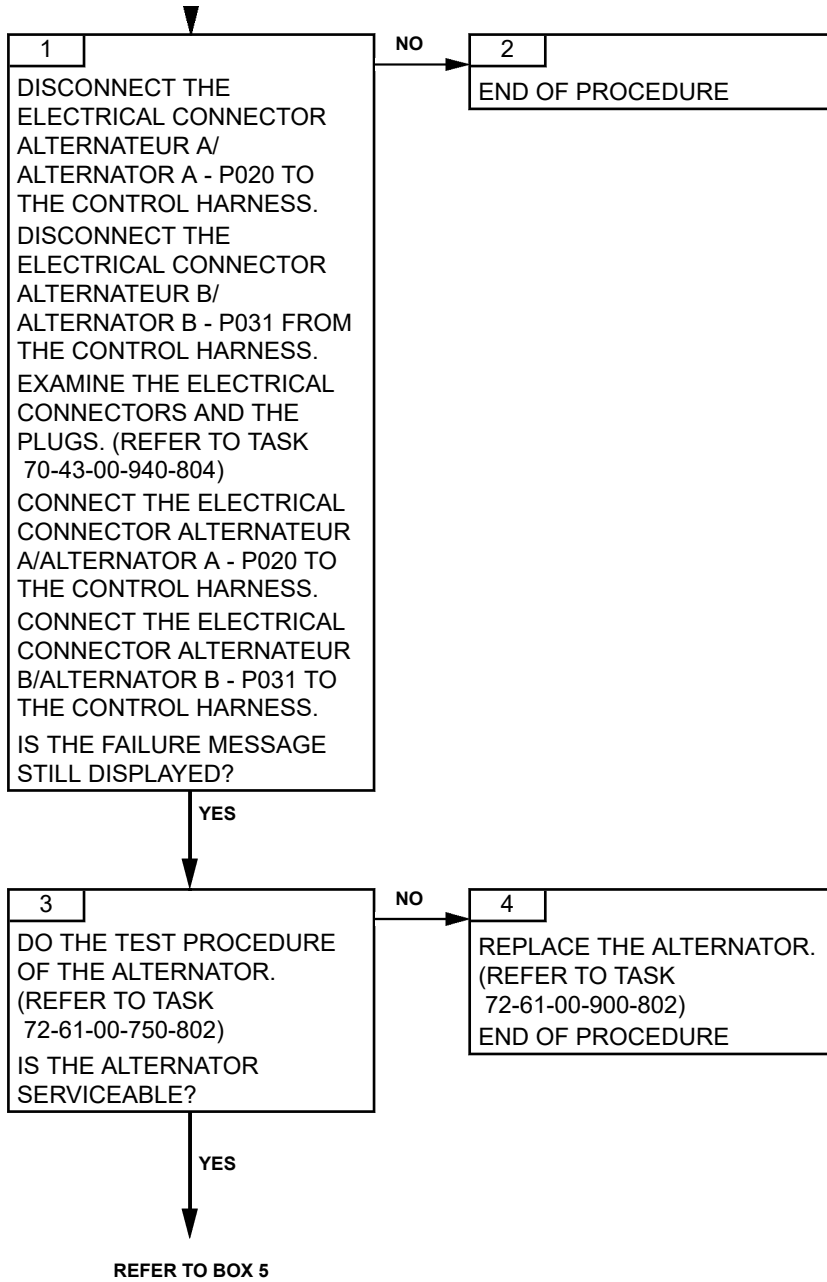

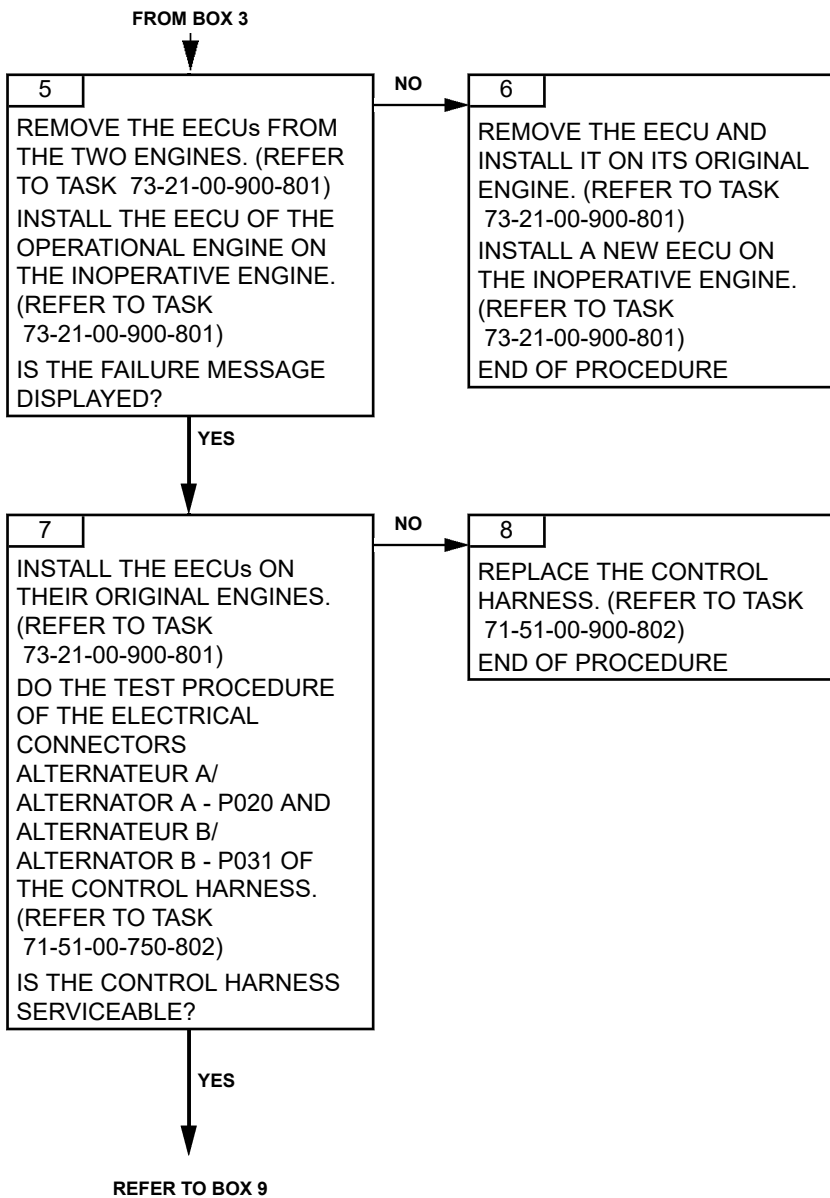

FROM BOX 7

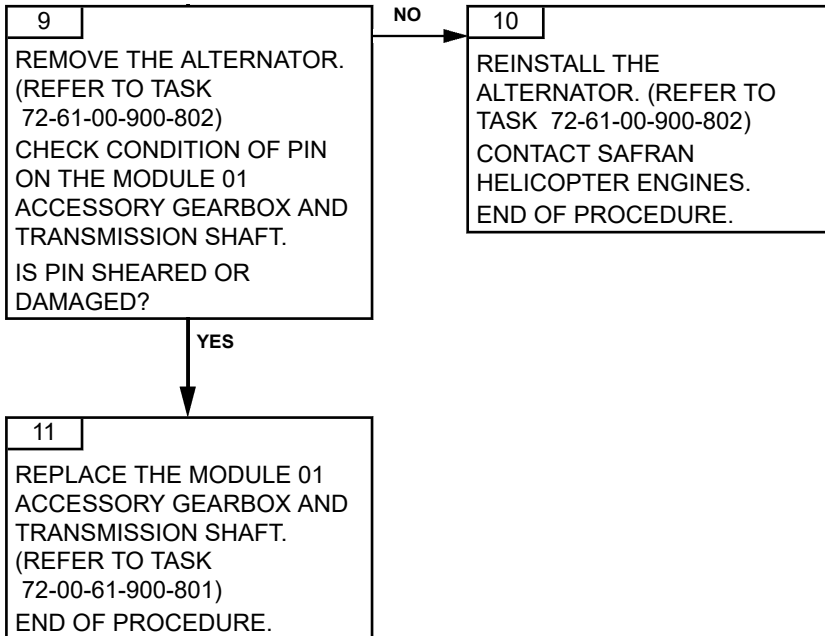

TASK 71-00-06-817-928-A01

HELICOPTER P0 FAILURE TROUBLESHOOTING

1. GENERAL

A. VEMD FAILURE MESSAGE

<i>VEMD MESSAGE</i>
H PO. A

B. FAILURE EFFECTS

<i>EFFECTS</i>	<i>CAD MESSAGE</i>
– If engine P0 is available: use of this value as backup. No effect except accuracy of the P0 used	flashing GOV
– If engine P0 not available: use of a backup value. No more P0 effect on N2 datum.	GOV

The helicopter P0 is sent to the EECU through the ARINC link label 215.

This message shows that the EECU operates correctly: an incorrect communication between the aircraft and the EECU can cause a "H. LINK A" or ARINC failure message.

CAUTION: MAKE SURE THAT THE CONCERNED AIRCRAFT SYSTEM IS SERVICEABLE BEFORE YOU SWAP THE ENGINE ELECTRONIC CONTROL UNITS.

CAUTION: WHEN CHECKING THE "FAIL" LINE ON THE VEMD SYSTEM STATUS PAGE, MAKE SURE TO CHECK ALL FAILURES. TO DO SO, PRESS THE SELECT KEY UNTIL A WHITE FRAME SURROUNDS THE "FAIL" LINE. THEN, USE "+/-" KEY TO VIEW ALL FAILURES. PROCEED THE SAME WAY TO CHECK ALL MESSAGES ON THE "MSG" LINE.

CAUTION: THE FAILURE INFORMATION ON THE VEMD SYSTEM STATUS PAGE MAY NO LONGER BE AVAILABLE AFTER BATTERY POWER IS TURNED OFF. THEREFORE, AFTER A FAILURE OCCURRED, IT IS VERY IMPORTANT TO CHECK AND WRITE DOWN ALL INFORMATION FROM THE "FAIL" LINE AND THE "MSG" LINE BEFORE TURNING BATTERY POWER OFF.

C. POSSIBLE CAUSES

- Helicopter P0 function (Aircraft system)

2. PROCEDURE

Effectivity: C1



1

CHECK HELICOPTER P0
FUNCTION/ACCURACY ON
THE AIRCRAFT SYSTEM.
REFER TO THE AIRCRAFT
MAINTENANCE MANUAL.
END OF PROCEDURE.

TASK 71-00-06-817-929-A01

NO HELICOPTER ARINC MESSAGE TROUBLESHOOTING

1. GENERAL

A. VEMD FAILURE MESSAGE

VEMD MESSAGE
H LINK. A

B. FAILURE EFFECTS

EFFECTS	CAD MESSAGE
Same effect as "Helicopter P0 failure" and "Helicopter T4.5 failure". Impossible to perform engine health check.	GOV

NOTE: *On ground, with engine switch in OFF position, when the VEMD is in the MAINTENANCE MODE, the VEMD stops sending the ARINC message to the EECU. In consequence, the EECU declares a HELICOPTER ARINC failure and the GOV light illuminates. This condition is reversible and the failure condition and GOV light will disappear as soon as the VEMD returns to the NORMAL mode.*

CAUTION: MAKE SURE THAT THE CONCERNED AIRCRAFT SYSTEM IS SERVICEABLE BEFORE YOU SWAP THE ENGINE ELECTRONIC CONTROL UNITS.

CAUTION: WHEN CHECKING THE "FAIL" LINE ON THE VEMD SYSTEM STATUS PAGE, MAKE SURE TO CHECK ALL FAILURES. TO DO SO, PRESS THE SELECT KEY UNTIL A WHITE FRAME SURROUNDS THE "FAIL" LINE. THEN, USE "+/-" KEY TO VIEW ALL FAILURES. PROCEED THE SAME WAY TO CHECK ALL MESSAGES ON THE "MSG" LINE.

CAUTION: THE FAILURE INFORMATION ON THE VEMD SYSTEM STATUS PAGE MAY NO LONGER BE AVAILABLE AFTER BATTERY POWER IS TURNED OFF. THEREFORE, AFTER A FAILURE OCCURRED, IT IS VERY IMPORTANT TO CHECK AND WRITE DOWN ALL INFORMATION FROM THE "FAIL" LINE AND THE "MSG" LINE BEFORE TURNING BATTERY POWER OFF.

C. POSSIBLE CAUSES

- EECU
- Helicopter ARINC message function (Aircraft system)
- Electrical harness

2. PROCEDURE

NOTE: *The EECU receives the helicopter ARINC signal at connector P2, pin 7 (high) and pin 3 (low).*

Effectivity: C1

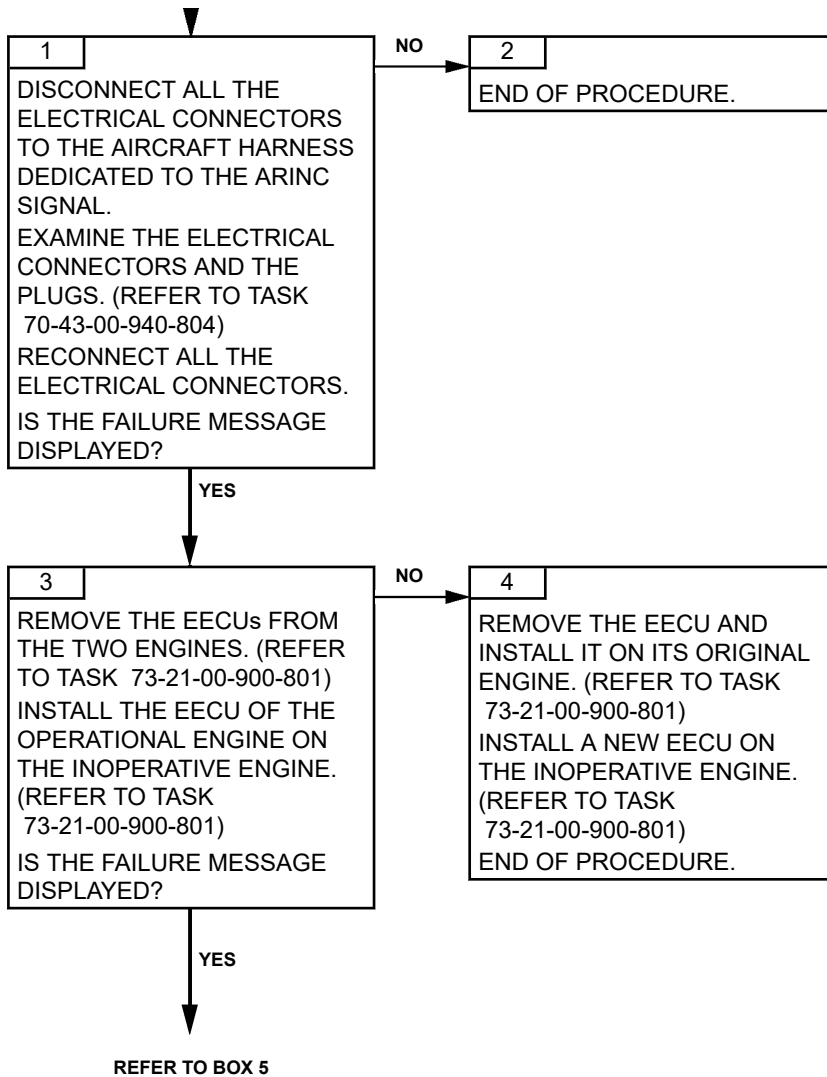

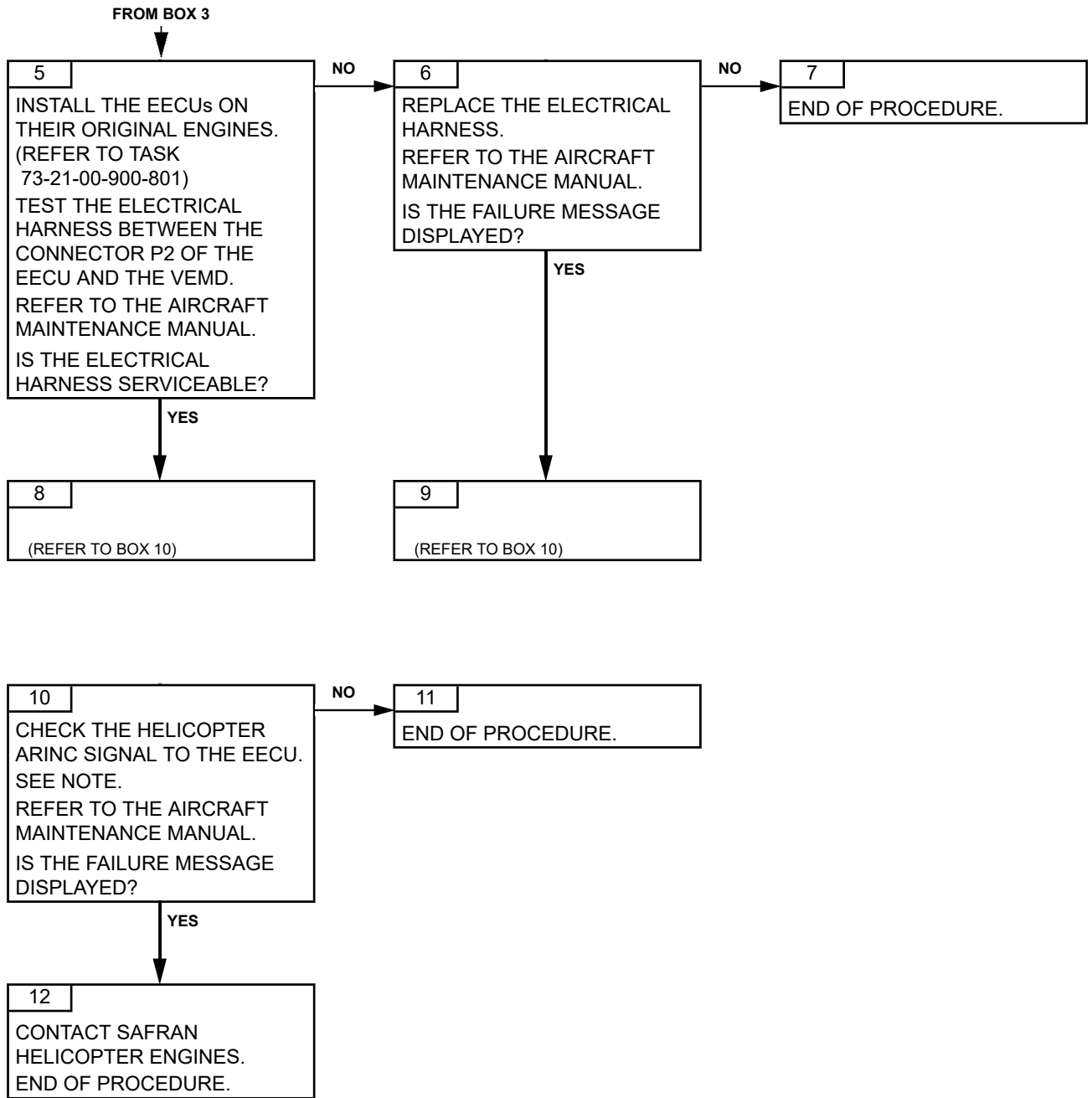

PAGE LEFT BLANK INTENTIONALLY

TASK 71-00-06-817-931-A01

ALTERNATOR FAILURE CHANNEL A AND CHANNEL B TROUBLESHOOTING

1. GENERAL

A. VEMD FAILURE MESSAGE

<i>VEMD MESSAGE</i>
ALTER. A and ALTER. B

B. FAILURE EFFECTS

<i>EFFECTS</i>	<i>CAD MESSAGE</i>
Loss of alternator power supply on both channels. Use of aircraft 28VDC power supply. No effect. This failure will occur only engine running, with NG greater than 70%.	flashing GOV

CAUTION: MAKE SURE THAT THE CONCERNED AIRCRAFT SYSTEM IS SERVICEABLE BEFORE YOU SWAP THE ENGINE ELECTRONIC CONTROL UNITS.

CAUTION: WHEN CHECKING THE "FAIL" LINE ON THE VEMD SYSTEM STATUS PAGE, MAKE SURE TO CHECK ALL FAILURES. TO DO SO, PRESS THE SELECT KEY UNTIL A WHITE FRAME SURROUNDS THE "FAIL" LINE. THEN, USE "+/-" KEY TO VIEW ALL FAILURES. PROCEED THE SAME WAY TO CHECK ALL MESSAGES ON THE "MSG" LINE.

CAUTION: THE FAILURE INFORMATION ON THE VEMD SYSTEM STATUS PAGE MAY NO LONGER BE AVAILABLE AFTER BATTERY POWER IS TURNED OFF. THEREFORE, AFTER A FAILURE OCCURRED, IT IS VERY IMPORTANT TO CHECK AND WRITE DOWN ALL INFORMATION FROM THE "FAIL" LINE AND THE "MSG" LINE BEFORE TURNING BATTERY POWER OFF.

C. POSSIBLE CAUSES

- Alternator
- EECU
- Control harness

2. PROCEDURE

Effectivity: C1

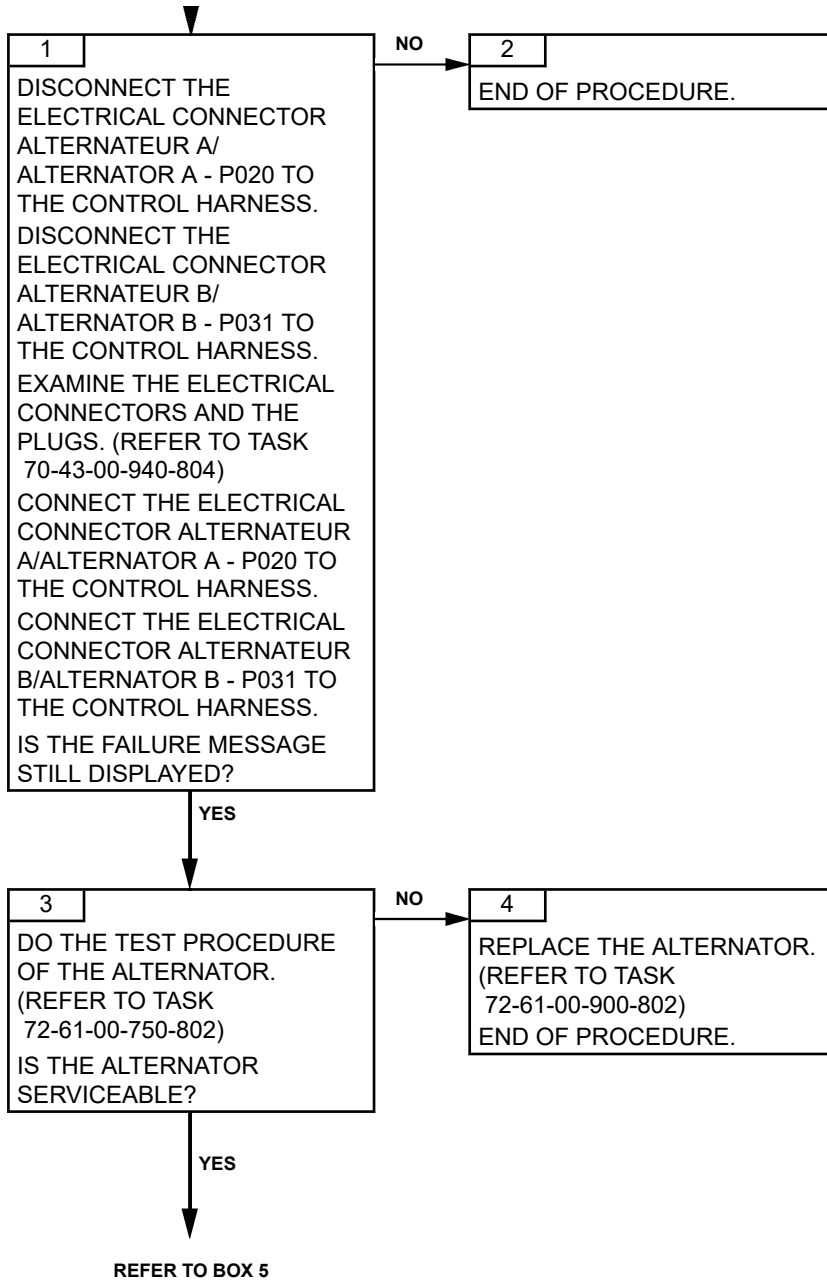

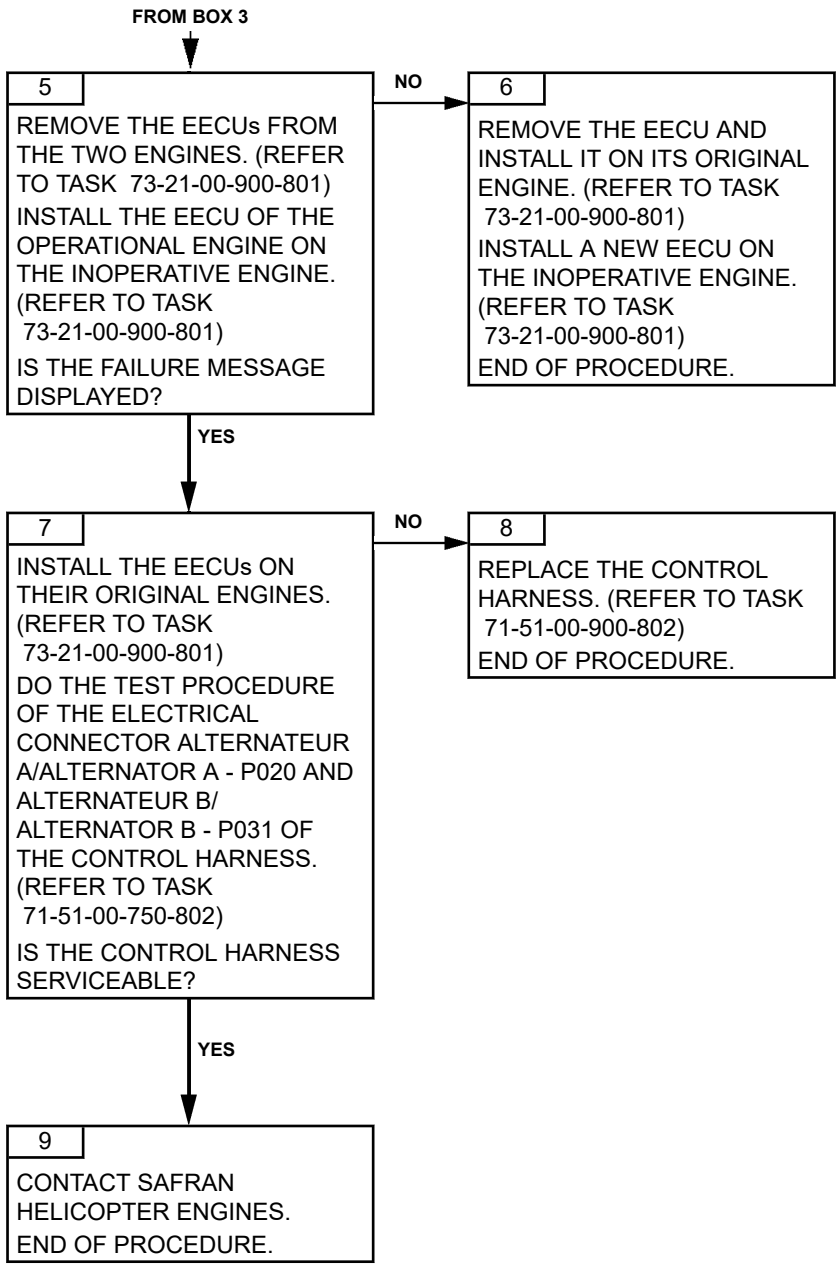

PAGE LEFT BLANK INTENTIONALLY

TASK 71-00-06-817-932-A01

**ALTERNATOR FAILURE A
TROUBLESHOOTING****1. GENERAL****A. VEMD FAILURE MESSAGE**

<i>VEMD MESSAGE</i>
ALTER. A

B. FAILURE EFFECTS

<i>EFFECTS</i>	<i>CAD MESSAGE</i>
Loss of alternator power supply on channel A. Use of aircraft 28VDC power supply. No effect. This failure will occur only engine running, with NG greater than 70%.	flashing GOV

CAUTION: MAKE SURE THAT THE CONCERNED AIRCRAFT SYSTEM IS SERVICEABLE BEFORE YOU SWAP THE ENGINE ELECTRONIC CONTROL UNITS.

CAUTION: WHEN CHECKING THE “FAIL” LINE ON THE VEMD SYSTEM STATUS PAGE, MAKE SURE TO CHECK ALL FAILURES. TO DO SO, PRESS THE SELECT KEY UNTIL A WHITE FRAME SURROUNDS THE “FAIL” LINE. THEN, USE “+/-” KEY TO VIEW ALL FAILURES. PROCEED THE SAME WAY TO CHECK ALL MESSAGES ON THE “MSG” LINE.

CAUTION: THE FAILURE INFORMATION ON THE VEMD SYSTEM STATUS PAGE MAY NO LONGER BE AVAILABLE AFTER BATTERY POWER IS TURNED OFF. THEREFORE, AFTER A FAILURE OCCURRED, IT IS VERY IMPORTANT TO CHECK AND WRITE DOWN ALL INFORMATION FROM THE “FAIL” LINE AND THE “MSG” LINE BEFORE TURNING BATTERY POWER OFF.

C. POSSIBLE CAUSES

- Alternator
- EECU
- Control harness

2. PROCEDURE

Effectivity: C1

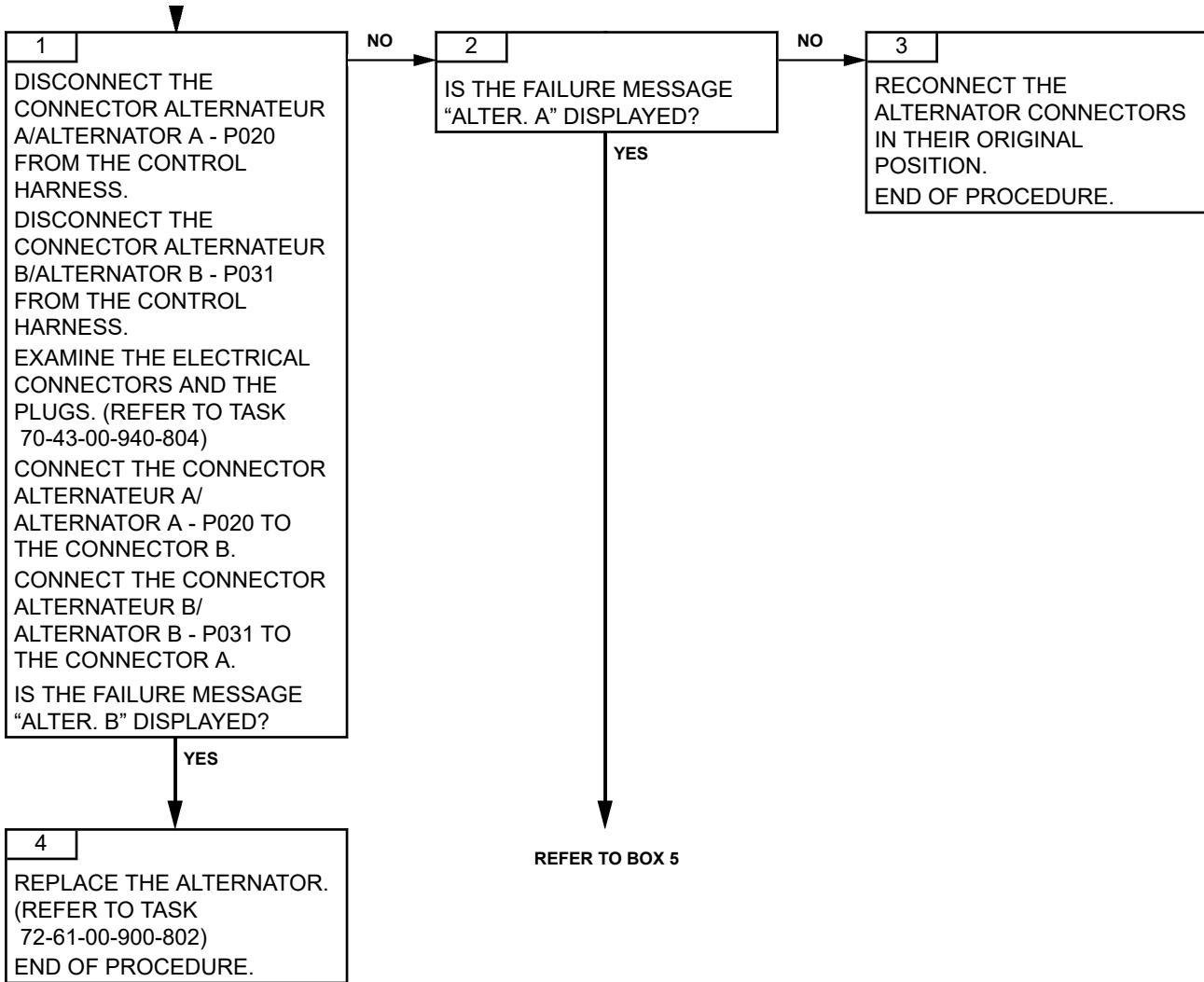

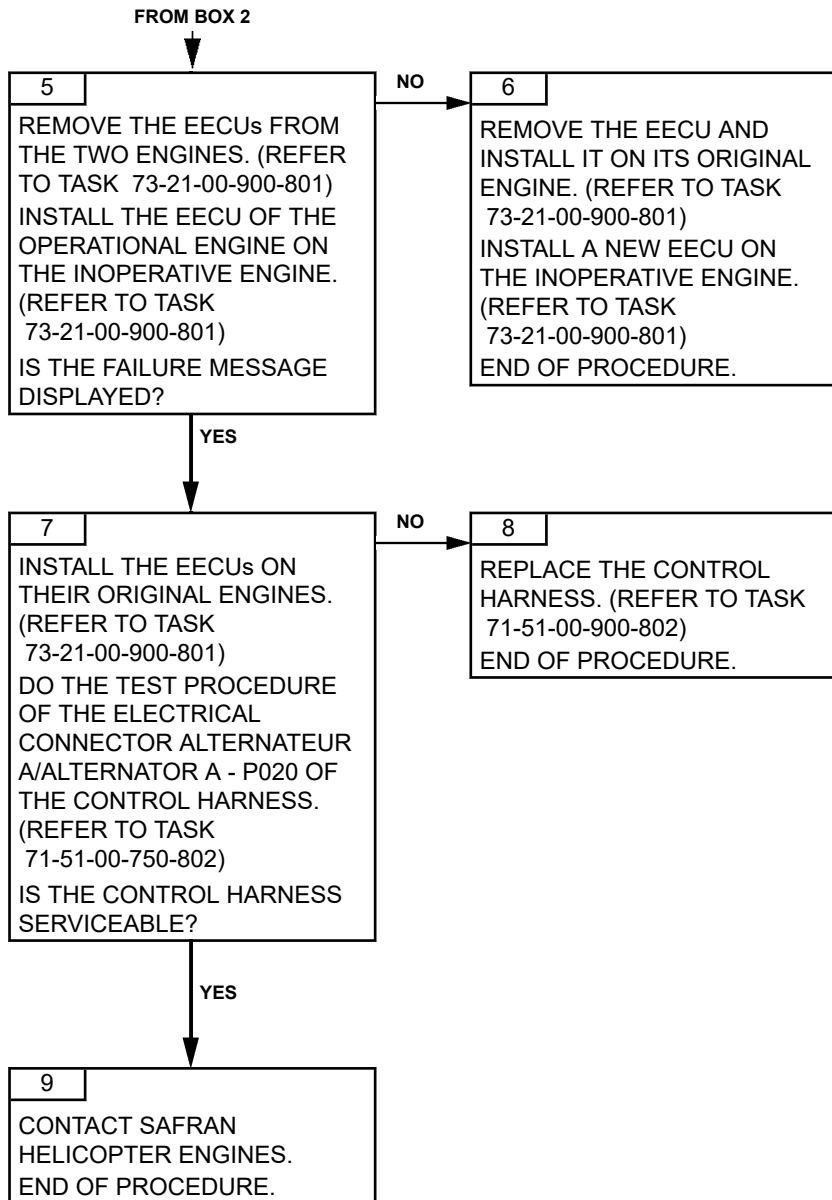

PAGE LEFT BLANK INTENTIONALLY

TASK 71-00-06-817-933-A01

**ALTERNATOR FAILURE B
TROUBLESHOOTING****1. GENERAL****A. VEMD FAILURE MESSAGE**

<i>VEMD MESSAGE</i>
ALTER. B

B. FAILURE EFFECTS

<i>EFFECTS</i>	<i>CAD MESSAGE</i>
Loss of alternator power supply on channel B. Use of aircraft 28VDC power supply. No effect. This failure will occur only engine running, with NG greater than 70%.	flashing GOV

CAUTION: MAKE SURE THAT THE CONCERNED AIRCRAFT SYSTEM IS SERVICEABLE BEFORE YOU SWAP THE ENGINE ELECTRONIC CONTROL UNITS.

CAUTION: WHEN CHECKING THE “FAIL” LINE ON THE VEMD SYSTEM STATUS PAGE, MAKE SURE TO CHECK ALL FAILURES. TO DO SO, PRESS THE SELECT KEY UNTIL A WHITE FRAME SURROUNDS THE “FAIL” LINE. THEN, USE “+/-” KEY TO VIEW ALL FAILURES. PROCEED THE SAME WAY TO CHECK ALL MESSAGES ON THE “MSG” LINE.

CAUTION: THE FAILURE INFORMATION ON THE VEMD SYSTEM STATUS PAGE MAY NO LONGER BE AVAILABLE AFTER BATTERY POWER IS TURNED OFF. THEREFORE, AFTER A FAILURE OCCURRED, IT IS VERY IMPORTANT TO CHECK AND WRITE DOWN ALL INFORMATION FROM THE “FAIL” LINE AND THE “MSG” LINE BEFORE TURNING BATTERY POWER OFF.

C. POSSIBLE CAUSES

- Alternator
- EECU
- Control harness

2. PROCEDURE

Effectivity: C1

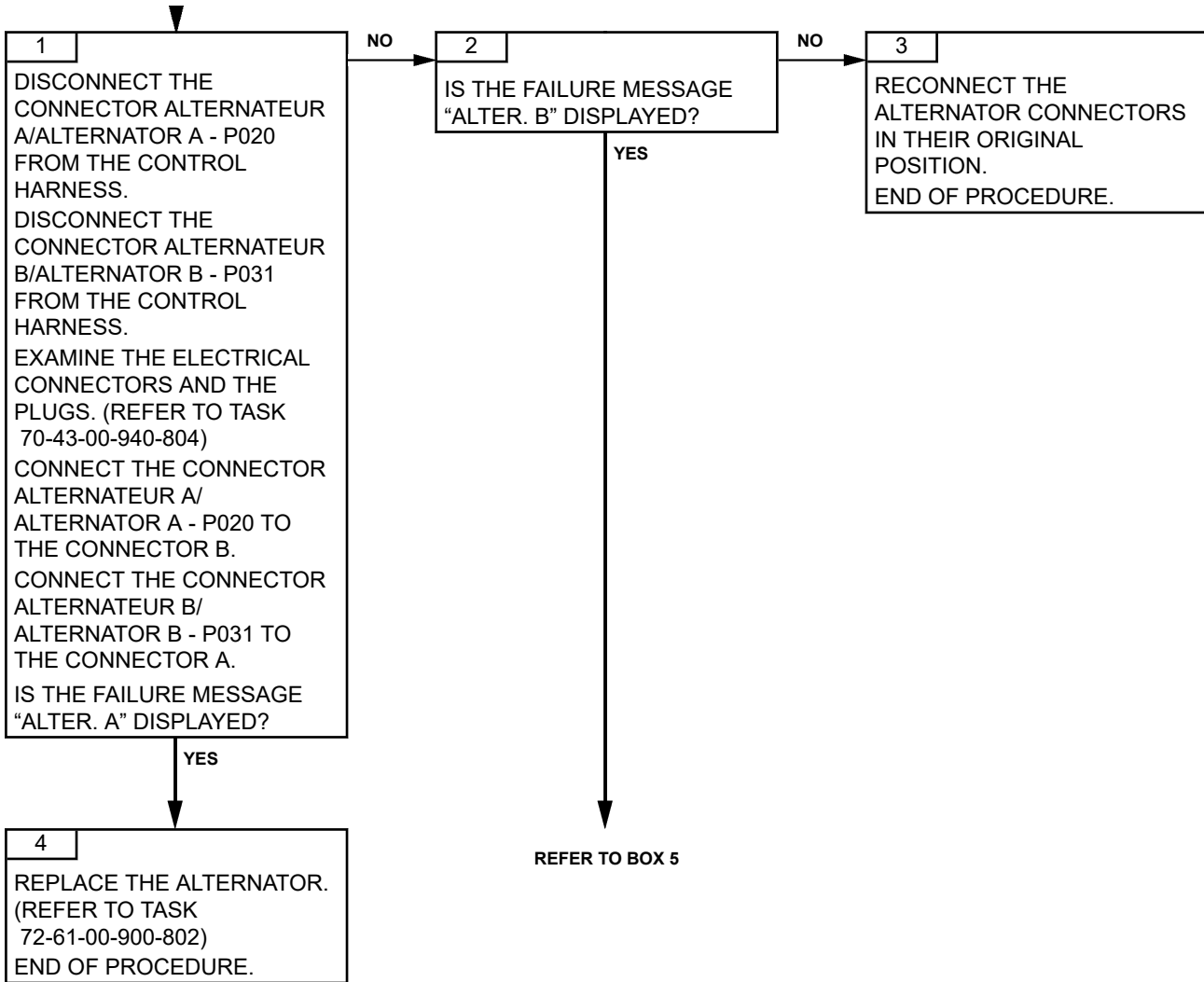

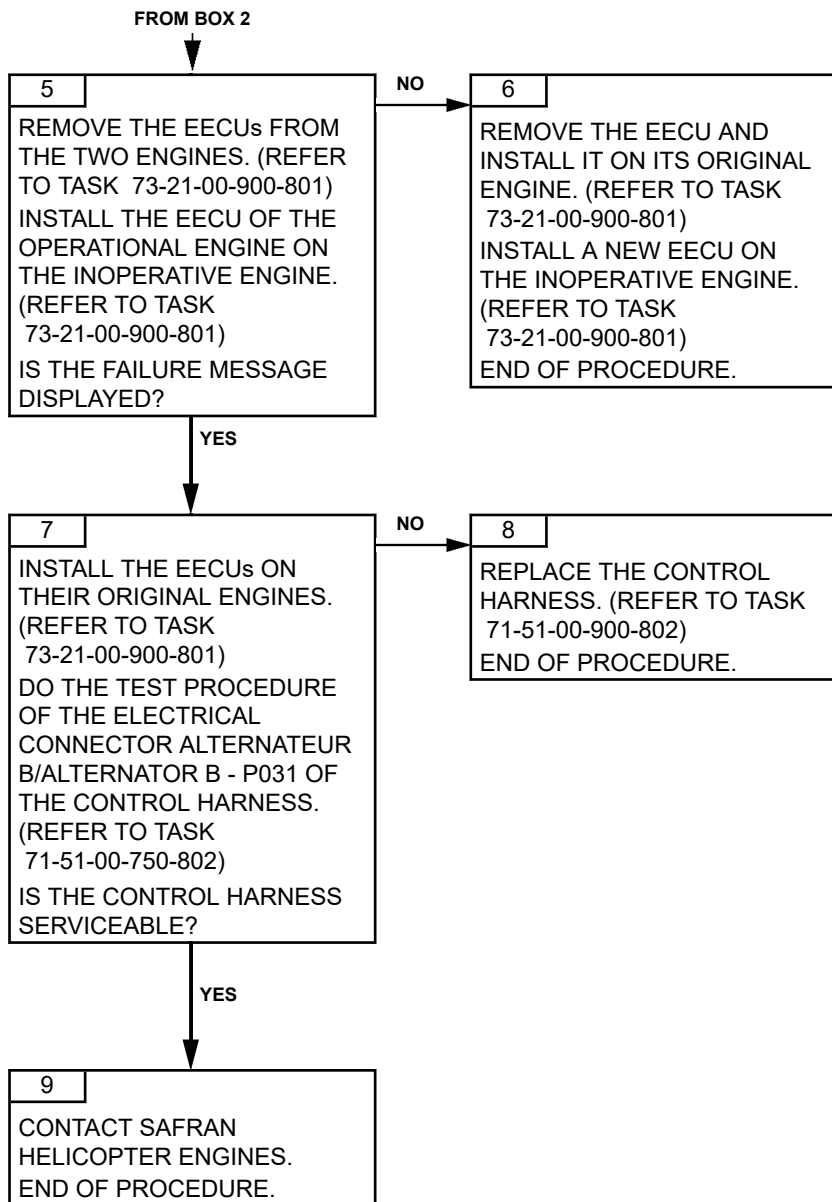

PAGE LEFT BLANK INTENTIONALLY

TASK 71-00-06-817-938-A01

**28V FAILURE A
TROUBLESHOOTING****1. GENERAL****A. VEMD FAILURE MESSAGE**

<i>VEMD MESSAGE</i>
28V. A

B. FAILURE EFFECTS

<i>EFFECTS</i>	<i>CAD MESSAGE</i>
<u>At starting:</u> Total failure of channel A – If no total failure of channel B: reversion to channel B – If total failure of channel B: start impossible.	flashing GOV FADEC
<u>Engine running:</u> Use of alternator power supply. No effect.	flashing GOV

CAUTION: MAKE SURE THAT THE CONCERNED AIRCRAFT SYSTEM IS SERVICEABLE BEFORE YOU SWAP THE ENGINE ELECTRONIC CONTROL UNITS.

CAUTION: WHEN CHECKING THE “FAIL” LINE ON THE VEMD SYSTEM STATUS PAGE, MAKE SURE TO CHECK ALL FAILURES. TO DO SO, PRESS THE SELECT KEY UNTIL A WHITE FRAME SURROUNDS THE “FAIL” LINE. THEN, USE “+/-” KEY TO VIEW ALL FAILURES. PROCEED THE SAME WAY TO CHECK ALL MESSAGES ON THE “MSG” LINE.

CAUTION: THE FAILURE INFORMATION ON THE VEMD SYSTEM STATUS PAGE MAY NO LONGER BE AVAILABLE AFTER BATTERY POWER IS TURNED OFF. THEREFORE, AFTER A FAILURE OCCURRED, IT IS VERY IMPORTANT TO CHECK AND WRITE DOWN ALL INFORMATION FROM THE “FAIL” LINE AND THE “MSG” LINE BEFORE TURNING BATTERY POWER OFF.

C. POSSIBLE CAUSES

- EECU
- 28V Power supply to channel A (Aircraft system)

2. PROCEDURE

NOTE: The EECU channel A receives the 28V aircraft power supply at connector P2, pin 54 (+) and pin 55 (-).

Effectivity: C1

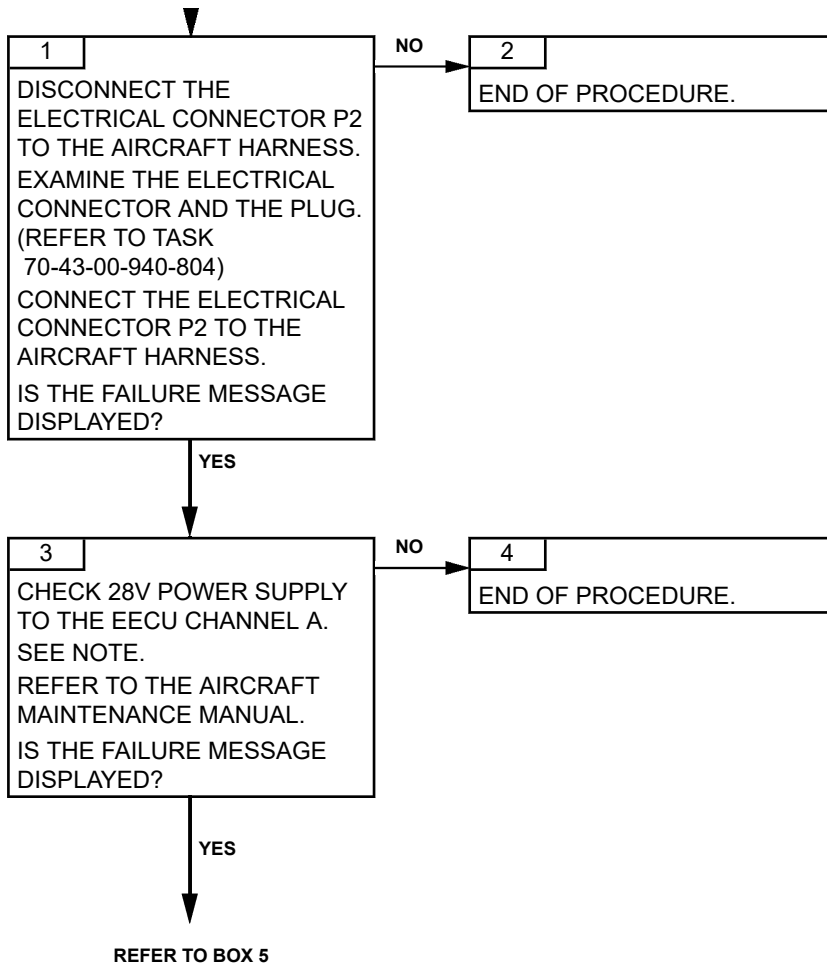

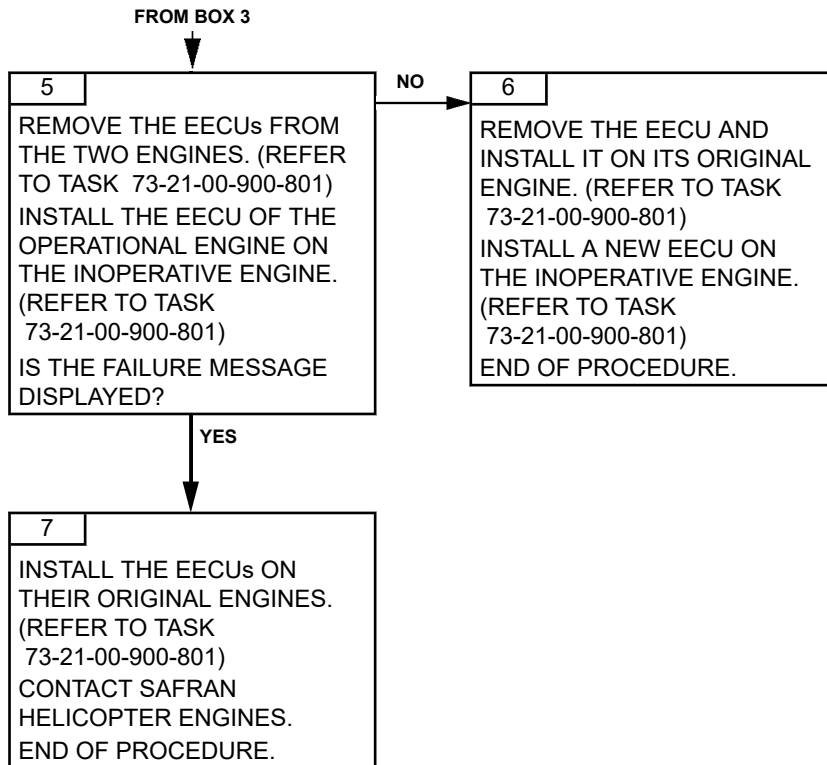

PAGE LEFT BLANK INTENTIONALLY

TASK 71-00-06-817-939-A01

**28V FAILURE B
TROUBLESHOOTING****1. GENERAL****A. VEMD FAILURE MESSAGE**

<i>VEMD MESSAGE</i>
28V. B

B. FAILURE EFFECTS

<i>EFFECTS</i>	<i>CAD MESSAGE</i>
<u>At starting:</u> Total failure of channel B – If channel A in control: no effect – If channel B in control after total failure of channel A: start impossible.	flashing GOV FADEC
<u>Engine running:</u> Use of alternator power supply. No effect.	flashing GOV

CAUTION: MAKE SURE THAT THE CONCERNED AIRCRAFT SYSTEM IS SERVICEABLE BEFORE YOU SWAP THE ENGINE ELECTRONIC CONTROL UNITS.

CAUTION: WHEN CHECKING THE “FAIL” LINE ON THE VEMD SYSTEM STATUS PAGE, MAKE SURE TO CHECK ALL FAILURES. TO DO SO, PRESS THE SELECT KEY UNTIL A WHITE FRAME SURROUNDS THE “FAIL” LINE. THEN, USE “+/-” KEY TO VIEW ALL FAILURES. PROCEED THE SAME WAY TO CHECK ALL MESSAGES ON THE “MSG” LINE.

CAUTION: THE FAILURE INFORMATION ON THE VEMD SYSTEM STATUS PAGE MAY NO LONGER BE AVAILABLE AFTER BATTERY POWER IS TURNED OFF. THEREFORE, AFTER A FAILURE OCCURRED, IT IS VERY IMPORTANT TO CHECK AND WRITE DOWN ALL INFORMATION FROM THE “FAIL” LINE AND THE “MSG” LINE BEFORE TURNING BATTERY POWER OFF.

C. POSSIBLE CAUSES

- EECU
- 28V Power supply to channel B (Aircraft system)

2. PROCEDURE

NOTE: The EECU channel B receives the 28V aircraft power supply at connector P4, pin 63(+) and pin 62 (-).

Effectivity: C1

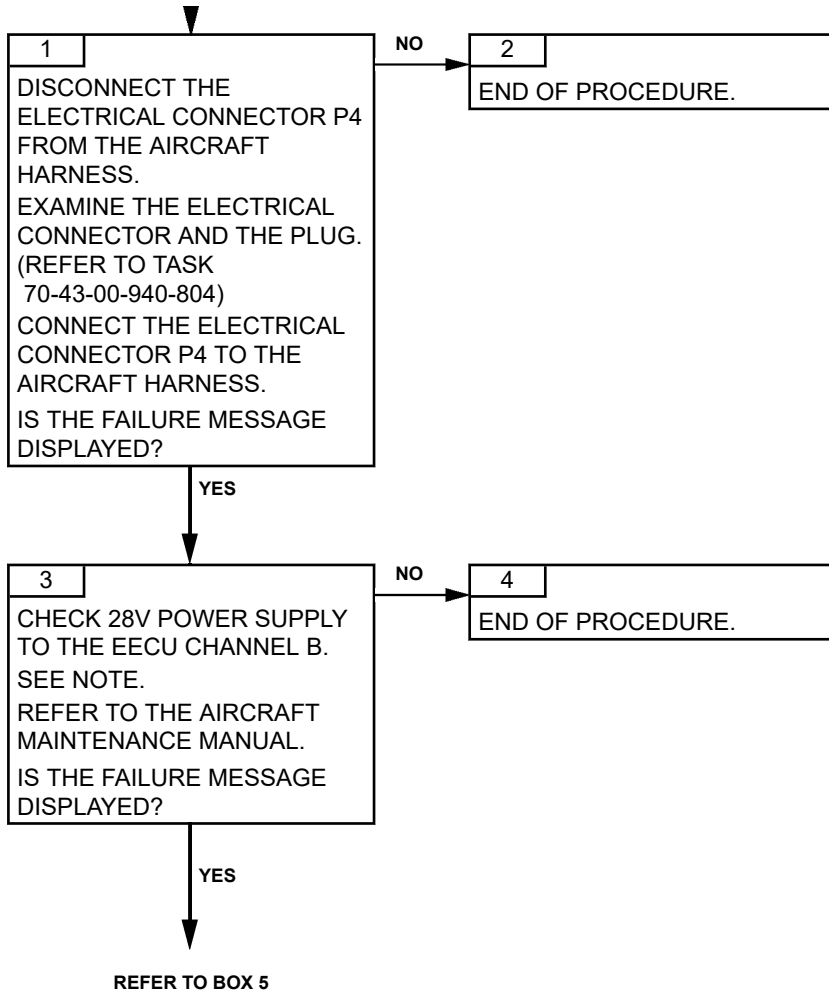

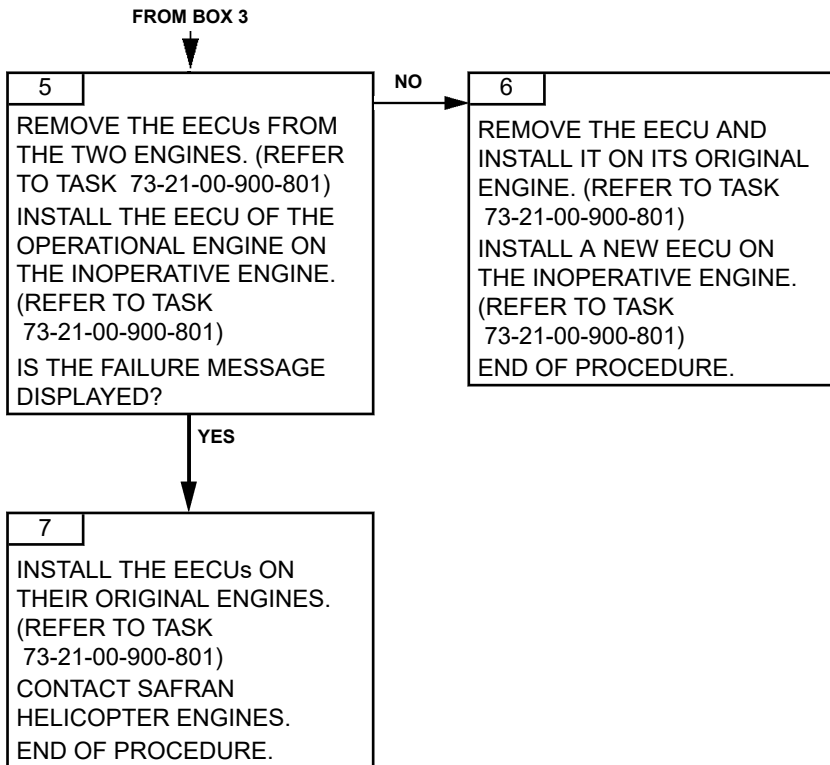

PAGE LEFT BLANK INTENTIONALLY

TASK 71-00-06-817-948-A01

**P0 INCONSISTENCY
TROUBLESHOOTING****1. GENERAL****A. VEMD FAILURE MESSAGE**

VEMD MESSAGE
P0 MIS. A

B. FAILURE EFFECTS

EFFECTS	CAD MESSAGE
– If engine P0 is available: use of this value as backup. No effect except accuracy of the P0 used	flashing GOV
– If engine P0 not available: use of a backup value. No more P0 effect on N2 datum.	GOV

NOTE: *P0 MIS. A will appear if the difference between the helicopter P0 and the EECU P0 is greater than 28 mbars. Helicopter P0 is received by the EECU via the ARINC link.*

CAUTION: MAKE SURE THAT THE CONCERNED AIRCRAFT SYSTEM IS SERVICEABLE BEFORE YOU SWAP THE ENGINE ELECTRONIC CONTROL UNITS.

CAUTION: WHEN CHECKING THE “FAIL” LINE ON THE VEMD SYSTEM STATUS PAGE, MAKE SURE TO CHECK ALL FAILURES. TO DO SO, PRESS THE SELECT KEY UNTIL A WHITE FRAME SURROUNDS THE “FAIL” LINE. THEN, USE “+/-” KEY TO VIEW ALL FAILURES. PROCEED THE SAME WAY TO CHECK ALL MESSAGES ON THE “MSG” LINE.

CAUTION: THE FAILURE INFORMATION ON THE VEMD SYSTEM STATUS PAGE MAY NO LONGER BE AVAILABLE AFTER BATTERY POWER IS TURNED OFF. THEREFORE, AFTER A FAILURE OCCURRED, IT IS VERY IMPORTANT TO CHECK AND WRITE DOWN ALL INFORMATION FROM THE “FAIL” LINE AND THE “MSG” LINE BEFORE TURNING BATTERY POWER OFF.

C. POSSIBLE CAUSES

- EECU
- Helicopter P0 function (Aircraft system)

2. PROCEDURE

NOTE: *This failure may occur during rapid change of ambient pressure. Please confirm that the failure disappear also in flight and not only on ground.*

Effectivity: C1

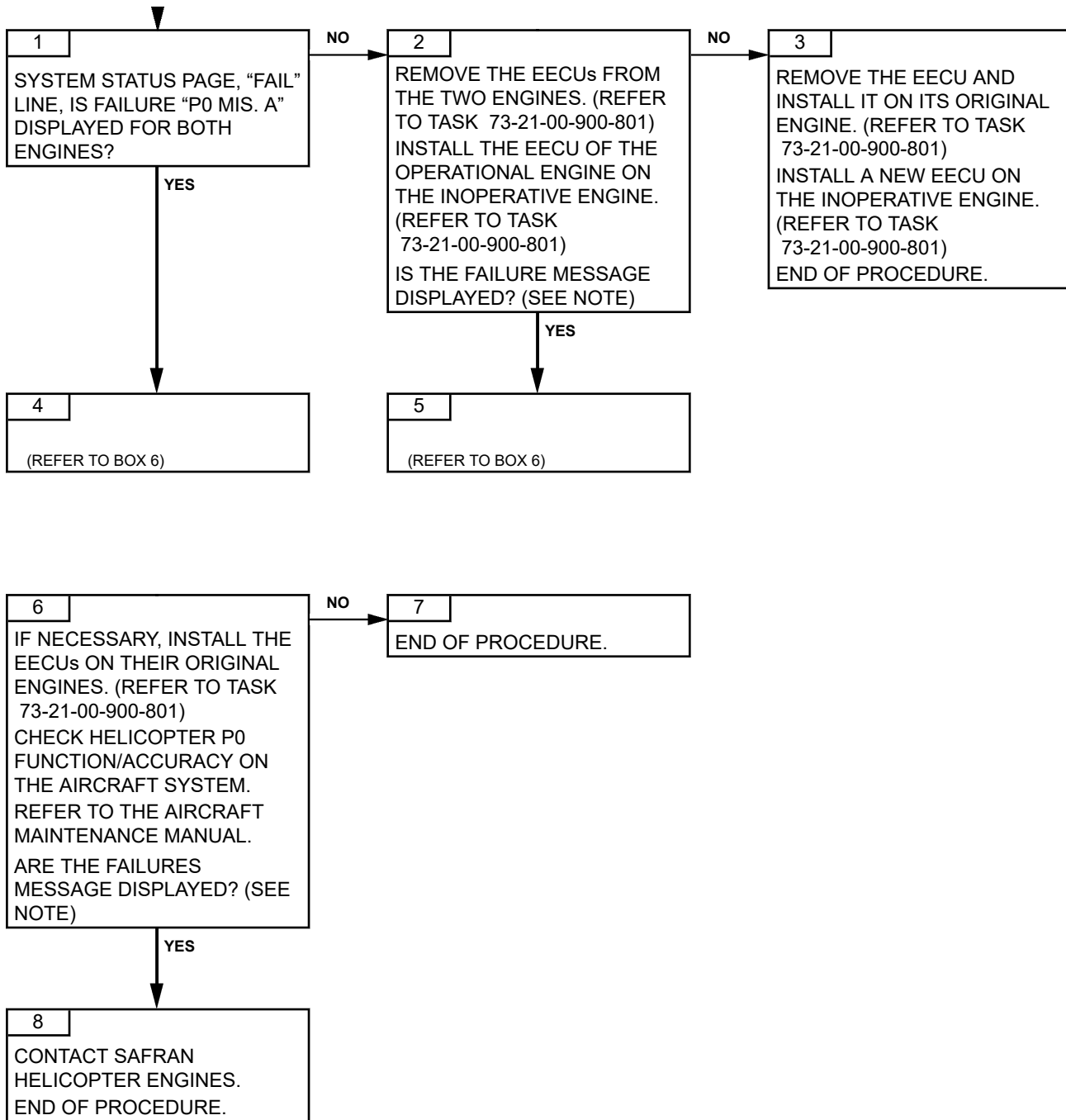

TASK 71-00-06-817-949-A01

**STOP ELECTRO-VALVE FAILURE
TROUBLESHOOTING****1. GENERAL****A. VEMD FAILURE MESSAGE**

VEMD MESSAGE
EL.V. A or EL.V. B

B. FAILURE EFFECTS

EFFECTS	CAD MESSAGE
At engine shutdown, the engine will not shut down immediately. After a few seconds, engine shutdown by stepper motor closing. Loss of overspeed protection function.	GOV

CAUTION: MAKE SURE THAT THE CONCERNED AIRCRAFT SYSTEM IS SERVICEABLE BEFORE YOU SWAP THE ENGINE ELECTRONIC CONTROL UNITS.

CAUTION: WHEN CHECKING THE “FAIL” LINE ON THE VEMD SYSTEM STATUS PAGE, MAKE SURE TO CHECK ALL FAILURES. TO DO SO, PRESS THE SELECT KEY UNTIL A WHITE FRAME SURROUNDS THE “FAIL” LINE. THEN, USE “+/-” KEY TO VIEW ALL FAILURES. PROCEED THE SAME WAY TO CHECK ALL MESSAGES ON THE “MSG” LINE.

CAUTION: THE FAILURE INFORMATION ON THE VEMD SYSTEM STATUS PAGE MAY NO LONGER BE AVAILABLE AFTER BATTERY POWER IS TURNED OFF. THEREFORE, AFTER A FAILURE OCCURRED, IT IS VERY IMPORTANT TO CHECK AND WRITE DOWN ALL INFORMATION FROM THE “FAIL” LINE AND THE “MSG” LINE BEFORE TURNING BATTERY POWER OFF.

C. POSSIBLE CAUSES

- EECU
- Stop electro-valve
- Control and monitoring harness
- Stop electro-valve control function (Aircraft system)

2. PROCEDURE

NOTE: *In normal operation, with the off/idle/flight switch on “off” position and battery power on, there should be a 28V power supply power to the “stop” solenoid of the stop electrovalve, at connector E.C. MA-AT/ON-OFF E.V. – P010, between pin 4 (+) and pin 2 (-).
At the aircraft interface, at plug J100 (interfacing with connector P100), with the off/idle/flight switch on “off” position there should be a 28 V power supply between pins 39 (+) and 8 (-).*

Effectivity: C1

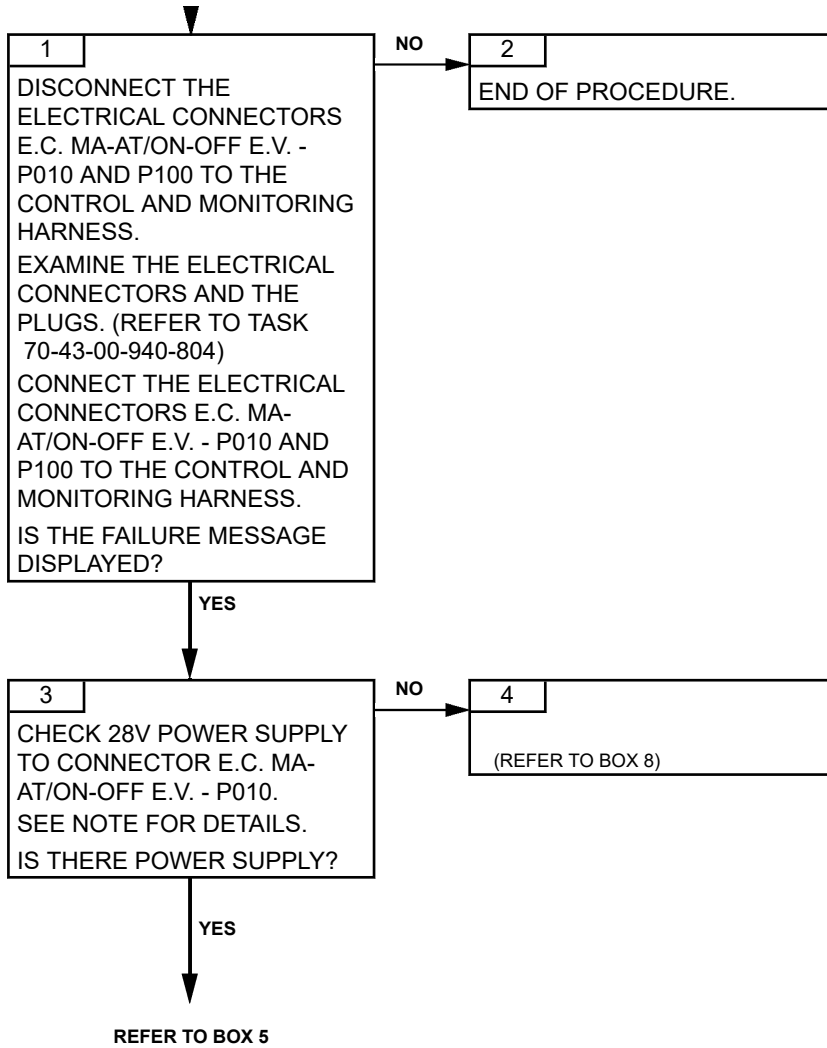

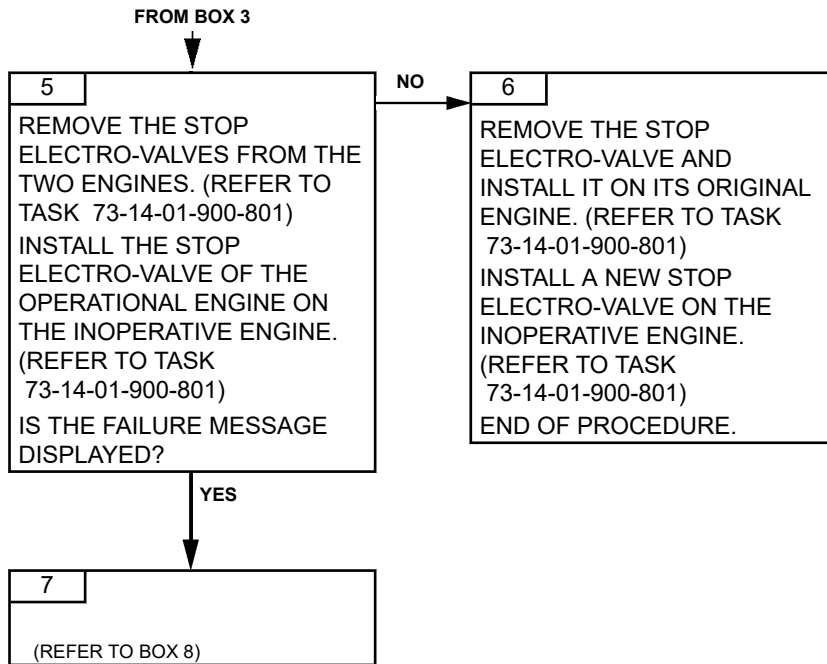

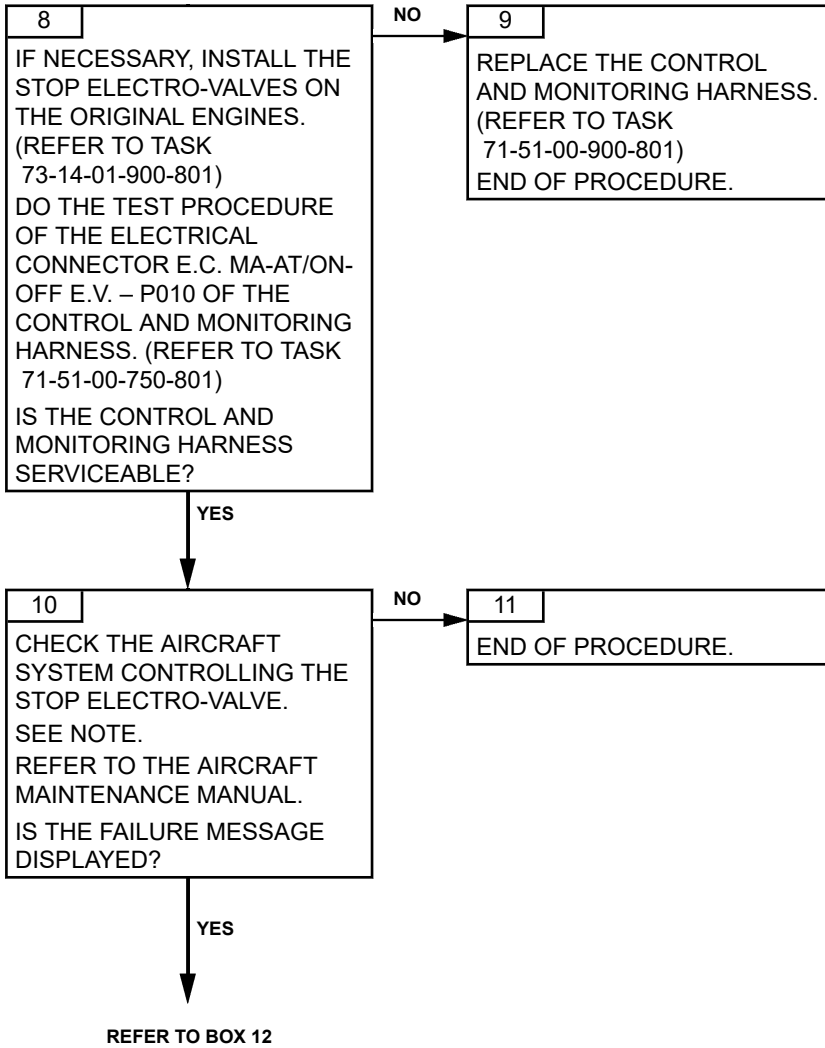

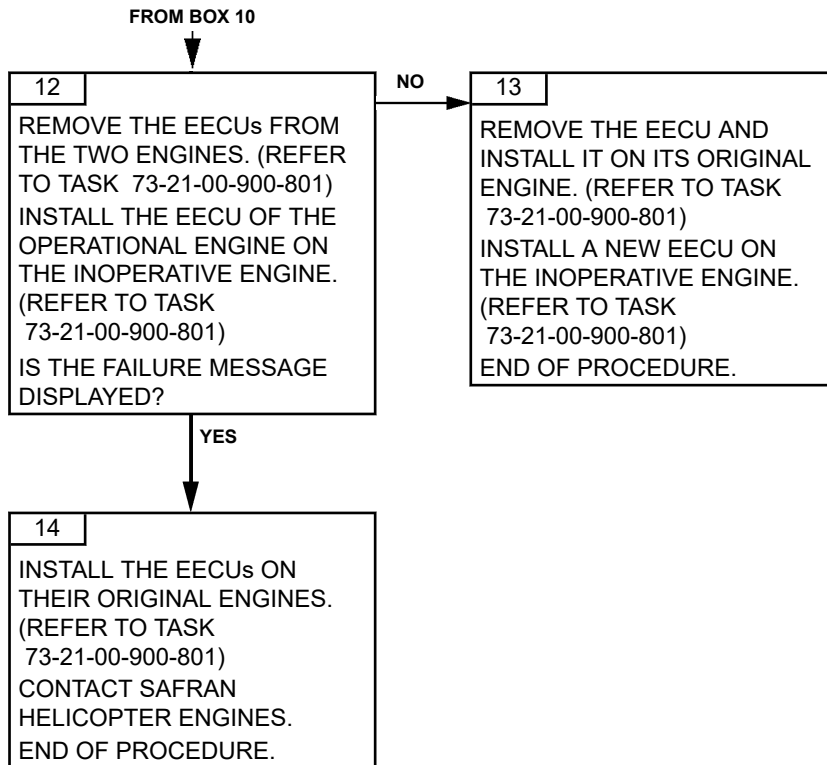

PAGE LEFT BLANK INTENTIONALLY

TASK 71-00-06-817-955-A01

**OVERSPEED PROTECTION FAILURE
TROUBLESHOOTING****1. GENERAL****A. VEMD FAILURE MESSAGE**

<i>VEMD MESSAGE</i>
OV/SP. A

B. FAILURE EFFECTS

<i>EFFECTS</i>	<i>CAD MESSAGE</i>
The overspeed protection is no longer available.	flashing GOV

CAUTION: DO NOT SWAP THE ENGINE INTERFACE BOX (AIRCRAFT MANUFACTURER RESPONSIBILITY) BETWEEN THE ENGINES FOR TROUBLESHOOTING. THIS MAY CAUSE ADDITIONAL DAMAGE TO THE ELECTRICAL CIRCUIT. INSTEAD, TEST THE COMPONENTS AS DESCRIBED IN THE PROCEDURE.

CAUTION: MAKE SURE THAT THE CONCERNED AIRCRAFT SYSTEM IS SERVICEABLE BEFORE YOU SWAP THE ENGINE ELECTRONIC CONTROL UNITS.

CAUTION: WHEN CHECKING THE “FAIL” LINE ON THE VEMD SYSTEM STATUS PAGE, MAKE SURE TO CHECK ALL FAILURES. TO DO SO, PRESS THE SELECT KEY UNTIL A WHITE FRAME SURROUNDS THE “FAIL” LINE. THEN, USE “+/-” KEY TO VIEW ALL FAILURES. PROCEED THE SAME WAY TO CHECK ALL MESSAGES ON THE “MSG” LINE.

CAUTION: THE FAILURE INFORMATION ON THE VEMD SYSTEM STATUS PAGE MAY NO LONGER BE AVAILABLE AFTER BATTERY POWER IS TURNED OFF. THEREFORE, AFTER A FAILURE OCCURRED, IT IS VERY IMPORTANT TO CHECK AND WRITE DOWN ALL INFORMATION FROM THE “FAIL” LINE AND THE “MSG” LINE BEFORE TURNING BATTERY POWER OFF.

C. POSSIBLE CAUSES

- Stop electro-valve
- N2 speed sensors
- Control harness
- Control and monitoring harness
- EECU
- EECU to control and monitoring harness wiring (Aircraft system).

2. PROCEDURE

NOTE: For the EECU to operate the stop electro-valve in case of overspeed, there must be continuity between:

- Connector P4 pin 64 and connector P010 pin 4

Effectivity: C1

- Connector P4 pin 65 and connector P010 pin 2.
Make sure to check both ways as there are some diodes in the wiring.

NOTE: Control harness wires used for the overspeed functions:

- Wire from P203 pin 41 to P201 pin 6
- Wire from P203 pin 47 to P201 pin 7.

NOTE: There should be continuity between:

- Connector P4 pin 64 (+) and plug J100 pin 39 (+)
 - Connector P4 pin 65 (-) and plug J100 pin 8 (-).
- Make sure to check both ways as there are some diodes in the wiring.
Plug J100 interfaces with control and monitoring harness connector P100.*

NOTE: Replace only the stop electro-valve, not the complete adjusted valve assembly. The rest of the adjusted valve assembly cannot cause the OV/SP. A failure.

NOTE: Experience shows that if the stop electro-valve has internal corrosion, it may pass the electrical test as per box 7 but is still the source of the OV/SP. A failure. If you suspect exposure to water or moisture, replace the stop electro-valve. Continue at box 15 only if the failure message is still present after stop electro-valve replacement.

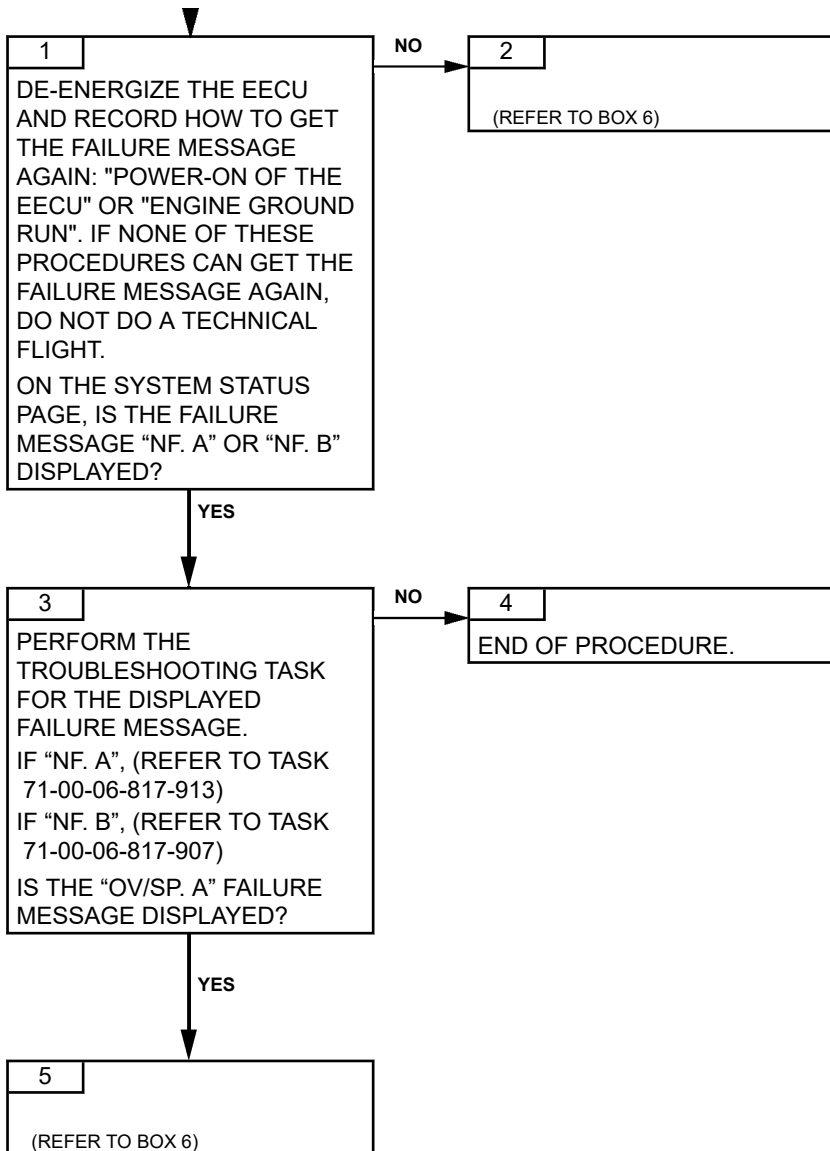

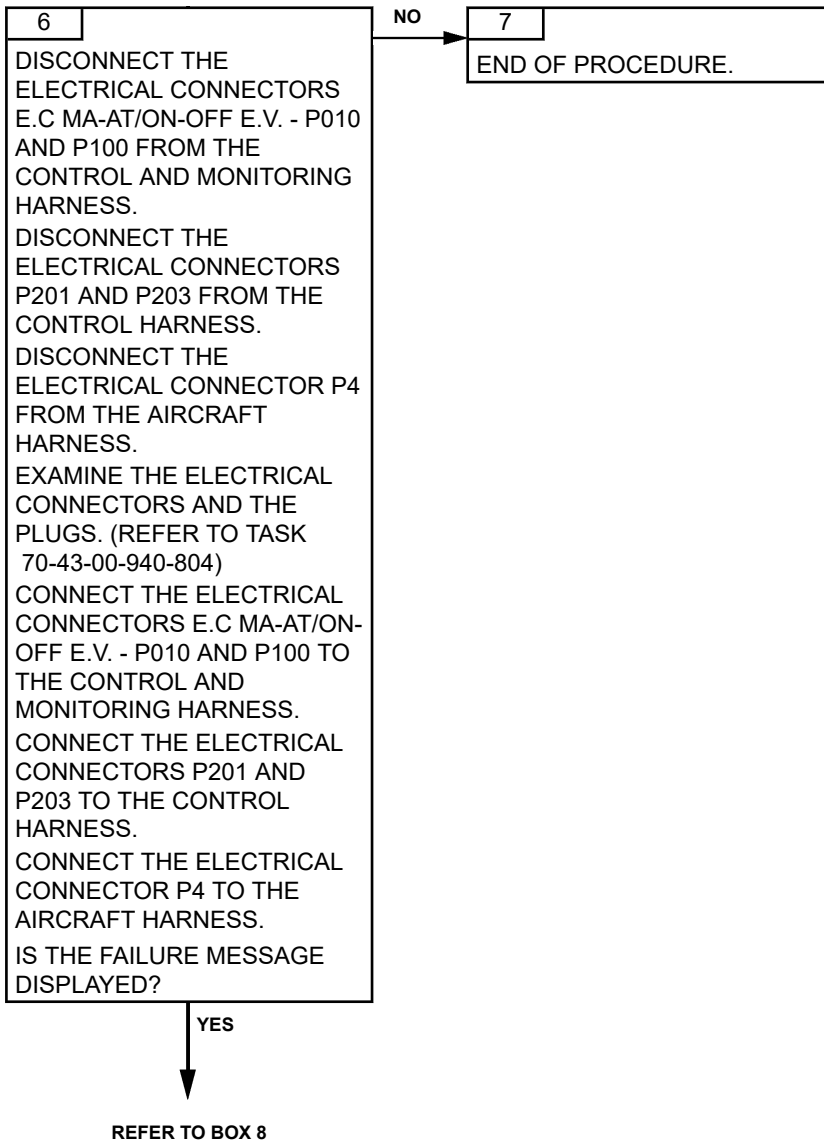

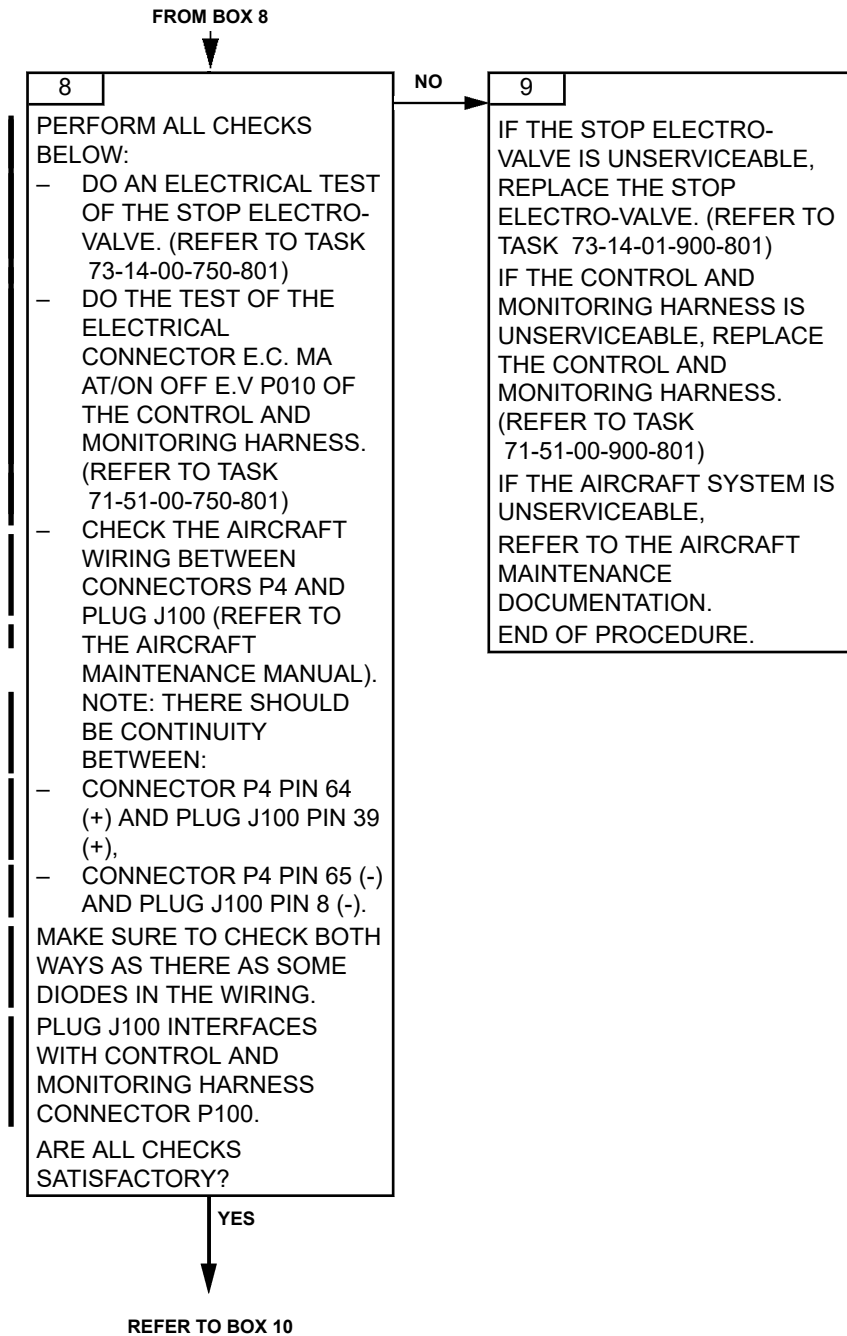

FROM BOX 8

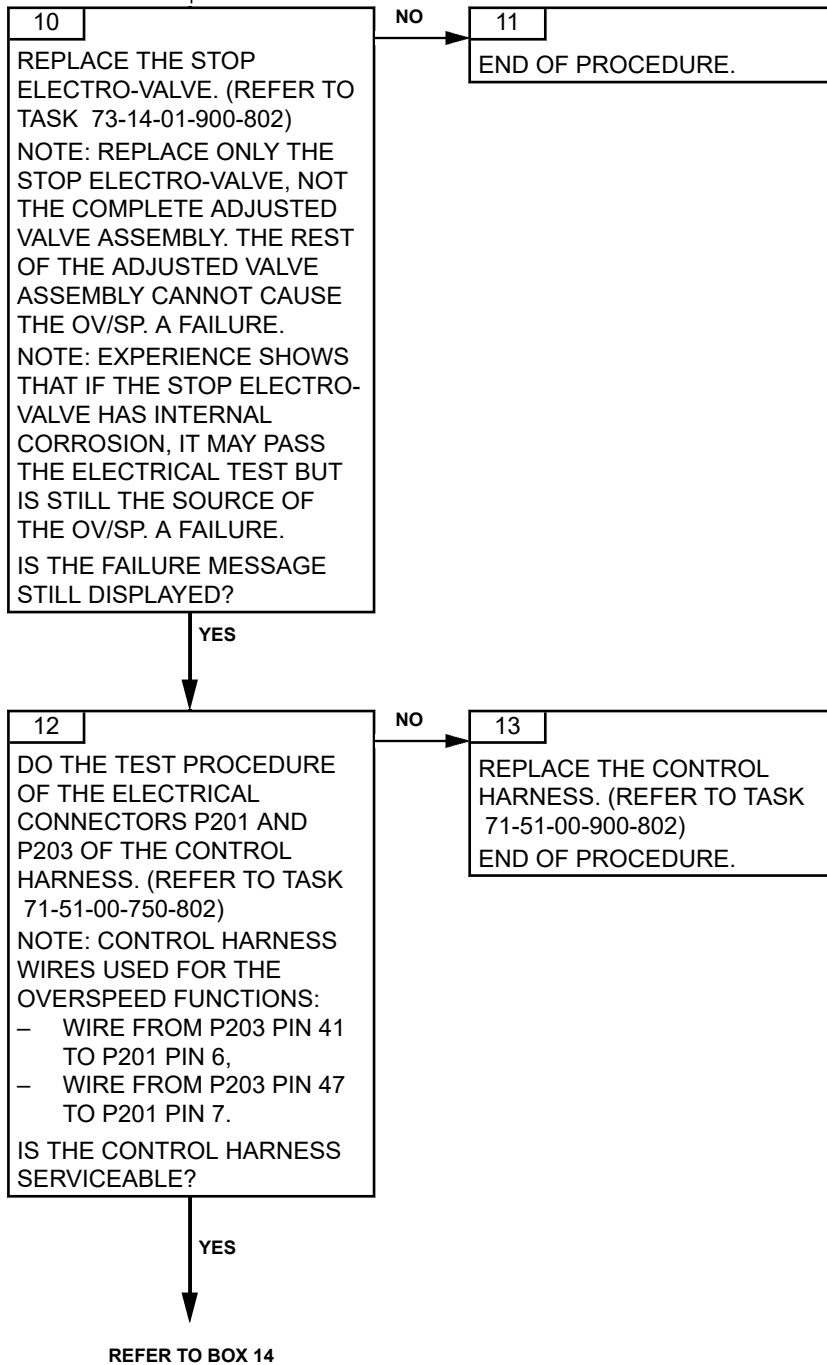

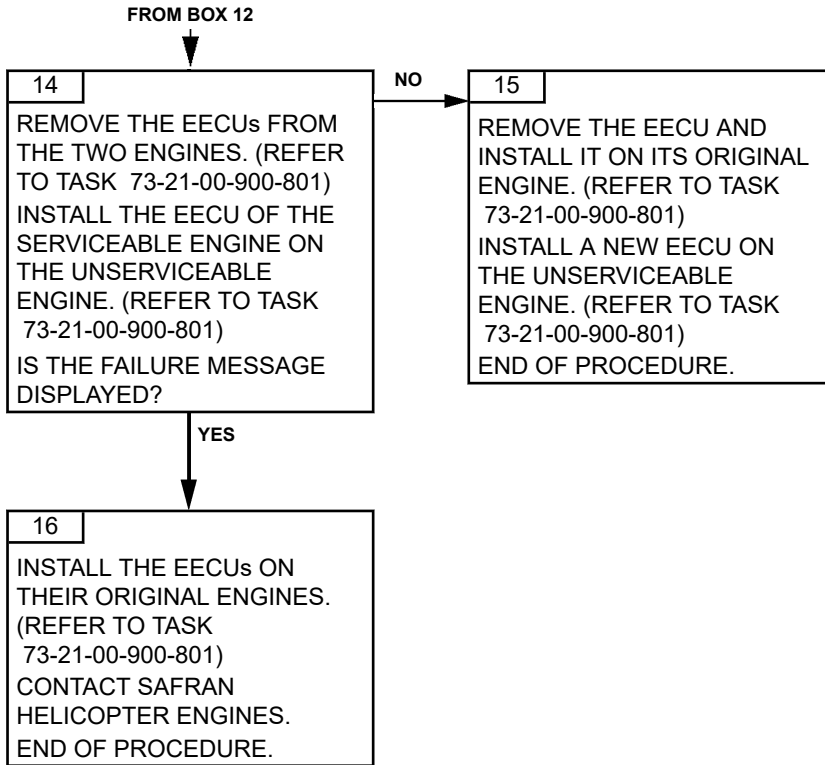

PAGE LEFT BLANK INTENTIONALLY

TASK 71-00-06-817-959-A01

**REAL TIME SOFTWARE FAILURE
TROUBLESHOOTING****1. GENERAL****A. VEMD FAILURE MESSAGE**

<i>VEMD MESSAGE</i>
SOFT. A or SOFT. B

B. FAILURE EFFECTS

<i>EFFECTS</i>	<i>CAD MESSAGE</i>
<u>If SOFT. A</u> Total failure of channel A. Automatic reversion to channel B.	flashing GOV
<u>If SOFT. B</u> Total failure of channel B	flashing GOV
– If channel A in control: no effect	FADEC
– If channel B in control after a channel A total failure: stepper motor freezing.	

CAUTION: MAKE SURE THAT THE CONCERNED AIRCRAFT SYSTEM IS SERVICEABLE BEFORE YOU SWAP THE ENGINE ELECTRONIC CONTROL UNITS.

CAUTION: WHEN CHECKING THE “FAIL” LINE ON THE VEMD SYSTEM STATUS PAGE, MAKE SURE TO CHECK ALL FAILURES. TO DO SO, PRESS THE SELECT KEY UNTIL A WHITE FRAME SURROUNDS THE “FAIL” LINE. THEN, USE “+/-” KEY TO VIEW ALL FAILURES. PROCEED THE SAME WAY TO CHECK ALL MESSAGES ON THE “MSG” LINE.

CAUTION: THE FAILURE INFORMATION ON THE VEMD SYSTEM STATUS PAGE MAY NO LONGER BE AVAILABLE AFTER BATTERY POWER IS TURNED OFF. THEREFORE, AFTER A FAILURE OCCURRED, IT IS VERY IMPORTANT TO CHECK AND WRITE DOWN ALL INFORMATION FROM THE “FAIL” LINE AND THE “MSG” LINE BEFORE TURNING BATTERY POWER OFF.

C. POSSIBLE CAUSES

- EECU

2. PROCEDURE

Effectivity: C1

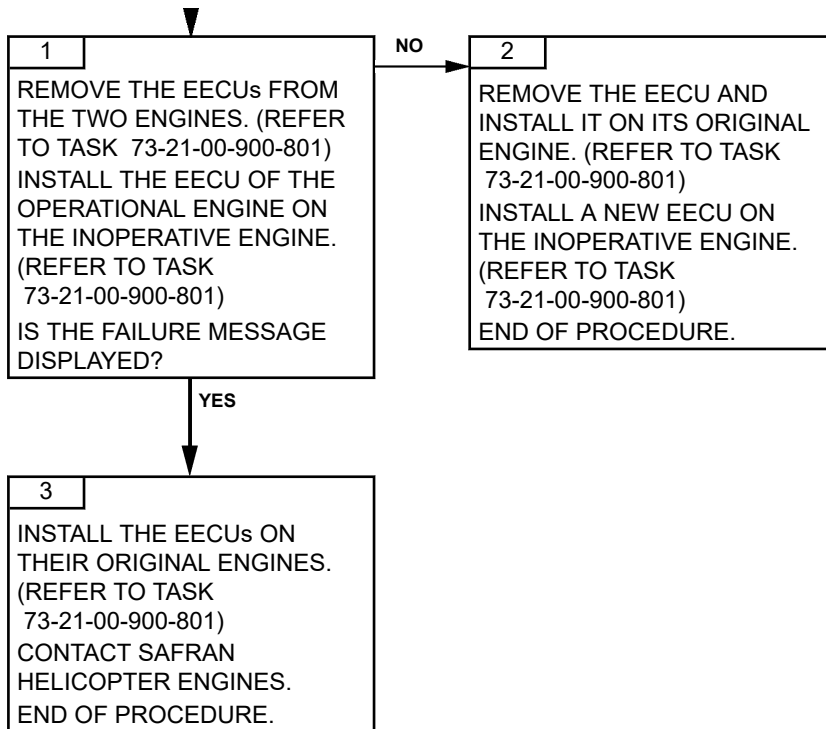

TASK 71-00-06-817-966-A01

**HMU OUT OF NEUTRAL POSITION
TROUBLESHOOTING****1. GENERAL****A. VEMD FAILURE MESSAGE**

<i>VEMD MESSAGE</i>
"OUT NEUTRL" and "DEGRADE" on "MSG" line no failure displayed on "FAIL" line

B. FAILURE EFFECTS

<i>EFFECTS</i>	<i>CAD MESSAGE</i>
At Power ON Start impossible.	GOV
<u>ENGINE RUNNING</u> The HMU is out of neutral while the EECU is in control. In normal operation, the HMU is out of neutral position only when the manual mode (EBCAU) is selected. Degraded operation, with slower engine acceleration and deceleration.	GOV

CAUTION: MAKE SURE THAT THE CONCERNED AIRCRAFT SYSTEM IS SERVICEABLE BEFORE YOU SWAP THE ENGINE ELECTRONIC CONTROL UNITS.

CAUTION: WHEN CHECKING THE "FAIL" LINE ON THE VEMD SYSTEM STATUS PAGE, MAKE SURE TO CHECK ALL FAILURES. TO DO SO, PRESS THE SELECT KEY UNTIL A WHITE FRAME SURROUNDS THE "FAIL" LINE. THEN, USE "+/-" KEY TO VIEW ALL FAILURES. PROCEED THE SAME WAY TO CHECK ALL MESSAGES ON THE "MSG" LINE.

CAUTION: THE FAILURE INFORMATION ON THE VEMD SYSTEM STATUS PAGE MAY NO LONGER BE AVAILABLE AFTER BATTERY POWER IS TURNED OFF. THEREFORE, AFTER A FAILURE OCCURRED, IT IS VERY IMPORTANT TO CHECK AND WRITE DOWN ALL INFORMATION FROM THE "FAIL" LINE AND THE "MSG" LINE BEFORE TURNING BATTERY POWER OFF.

C. POSSIBLE CAUSES

- HMU
- EECU
- Control harness
- EBCAU function (Aircraft system)

Effectivity: C1

NOTE: *This message also indicates potential malfunction of the EBCAU system, which is part of the aircraft supply. Make sure that the related aircraft system is serviceable before replacing engine accessories.*

2. PROCEDURE

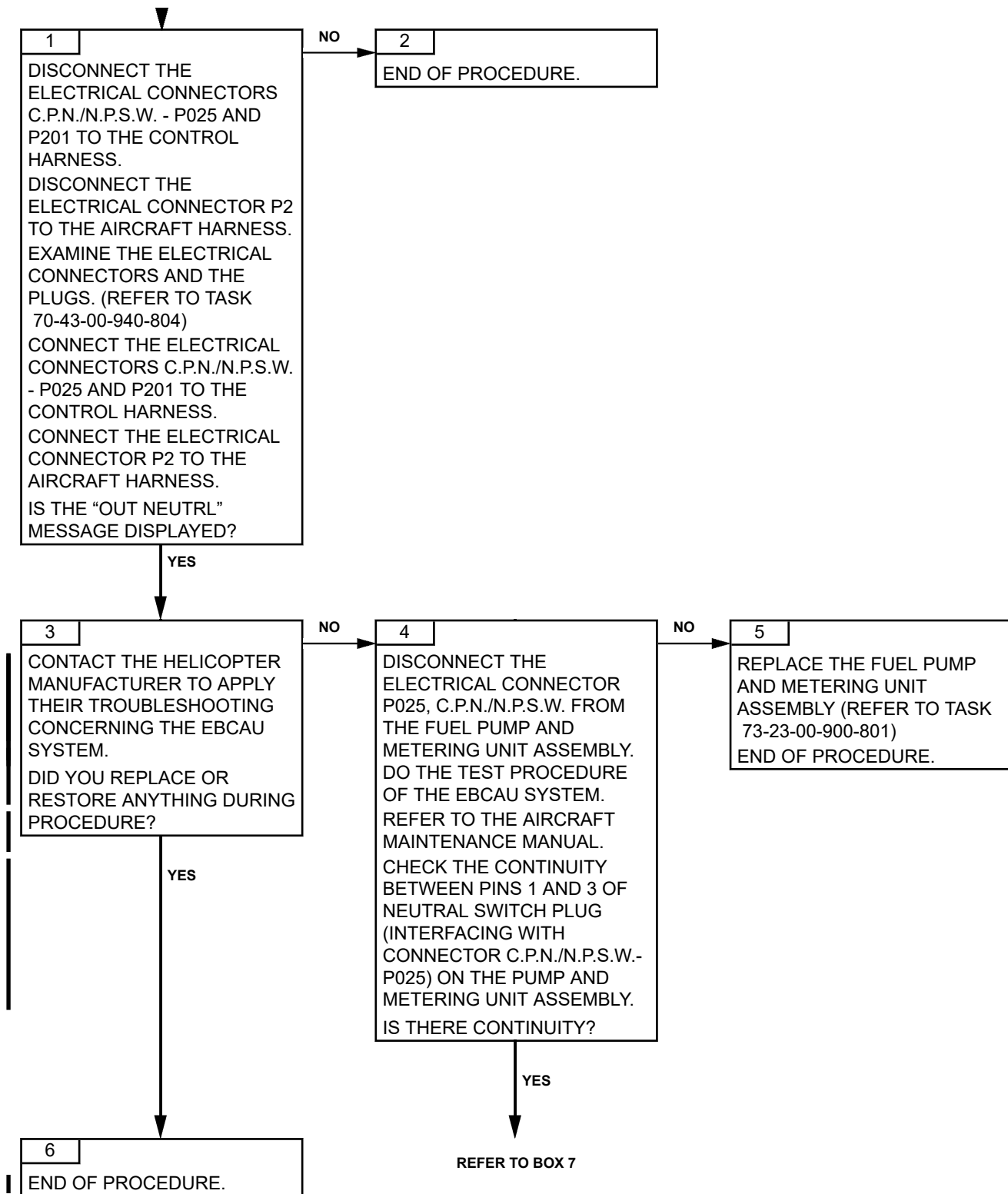

Effectivity: C1

