

Temporary Maintenance Instruction TMI 139-566

**Tail rotor head installation - Lag
damper spherical bearings – Detailed
inspection.**

All AW139 Helicopters

The technical content of this document is approved under the authority of DOA nr. EASA.21J.005.

The present TMI will be evaluated for its introduction in the standard set of Technical Publication.

If no further notice is received, the present document expires on: April 27th 2024.

2023-04-27

Introduction

This TMI provides the instructions and requirements to perform the Tail rotor head installation - Lag damper spherical bearings – Detailed inspection.

Following procedure contained in this TMI is not included in any existing Data Module inside IETP:

ANNEX	DATA MODULE CODE	DATA MODULE TITLE
Annex 1	39-A-64-21-00-00A-31AA-A	Tail rotor head installation - Lag damper spherical bearings – Detailed inspection.

The content of this TMI will be endorsed within the applicable Maintenance Manual at the earliest opportunity.

ANNEX 1

Tail rotor head installation - Lag damper spherical bearings - Detailed inspection

Table of contents

References	1
Preliminary requirements	2
Procedure	3
Requirements After Job Completion	7

List of tables

1 References	1
2 Access points	2
3 Zones	2
4 Required Conditions	2
5 Support Equipment	2
6 Supplies	3
7 Spares	3

List of figures

1 Tail rotor head installation - Lag damper spherical bearings - Detailed inspection on installed lag damper (Sheet 1 of 5)	8
1 Tail rotor head installation - Lag damper spherical bearings - Detailed inspection on installed lag damper (Sheet 2 of 5)	9
1 Tail rotor head installation - Lag damper spherical bearings - Detailed inspection on installed lag damper (Sheet 3 of 5)	10
1 Tail rotor head installation - Lag damper spherical bearings - Detailed inspection on installed lag damper (Sheet 4 of 5)	11
1 Tail rotor head installation - Lag damper spherical bearings - Detailed inspection on installed lag damper (Sheet 5 of 5)	12
2 Tail rotor head installation - Lag damper spherical bearings - Detailed inspection on removed lag damper	13

References

Table 1 References

Data Module	Title
39-A-00-20-00-00A-120A-A	Helicopter safety - Pre-operation (make helicopter safe for maintenance)
39-A-64-21-02-00A-520A-A	Lag damper - Remove procedure
39-A-64-21-02-00A-720A-A	Lag damper - Install procedure
39-A-64-21-02-01A-921A-B	Rod end (lag damper) - Replacement (remove and install a new item)

Table 2 Access points

Access Panel / Door Id	Data Module
No Access Point	

Table 3 Zones

Access Panel / Door Id	Data Module
No Zones	

Preliminary Requirements

Required Conditions

Table 4 Required Conditions

Conditions	Data Module/Technical Publication
The helicopter must be safe for maintenance	39-A-00-20-00-00A-120A-A

Support Equipment

Table 5 Support Equipment

Nomenclature	Identification No.	Qty
Support assy, dial gauge (sciss./swash. T/R damper hub side)	GF-54-04	1
Support assy, dial gauge (T/R damper blade side)	GF-54-07	1

Table 5 Support Equipment

Nomenclature	Identification No.	Qty
Dial gauge	GF-54-08	1
Extension, dial gauge	GF-54-09	1
Support arm, dial gauge	GF-54-10	1
V-block	ZZ-00-00	1
Dial gauge	ZZ-00-00	1
Platform, right	GG-02-00	1

Supplies

Table 6 Supplies

Nomenclature
No Supplies

Spares

Table 7 Spares

Nomenclature
No Spares

Safety Conditions

No Safety Condition

Procedure

- 1 Detailed inspection on installed lag damper.
 - 1.1 Put the [Platform, right \(GG-02-00\)](#) adjacent to the right side of the fuselage.
 - 1.2 Turn the tail rotor (4, [Figure 1](#)). Put the blade with the lag damper (2) that you must examine in the six o'clock position.
 - 1.3 Examine the spherical bearing in the housing (1) for fretting, corrosion, loss of liner parts, displacement or rotation in its housing.
 - 1.3.1 If you find the given damages to the spherical bearing:
 - 1.3.1.1 Remove the lag damper (2). Refer to [39-A-64-21-02-00A-520A-A](#).

- 1.3.1.2 Send the lag damper (2) to the Manufacturer for the replacement of the spherical bearing.
- 1.3.1.3 Install a new lag damper (2) on the tail rotor. Refer to [39-A-64-21-02-00A-720A-A](#).
- 1.3.1.4 Continue with [step 4](#).
- 1.3.2 If you do not find damage to the spherical bearing, continue with [step 1.4](#).
- 1.4 Examine the spherical bearing in the rod end (3) for fretting, corrosion, loss of liner parts, displacement or rotation in its housing.
 - 1.4.1 If you find damage to the spherical bearing:
 - 1.4.1.1 Remove the lag damper (2) and replace the rod end (3). Refer to [39-A-64-21-02-01A-921A-B](#).
 - 1.4.1.2 Install the lag damper (2) on the tail rotor. Refer to [39-A-64-21-02-00A-720A-A](#).
 - 1.4.1.3 Continue with [step 4](#).
 - 1.4.2 If you do not find damage to the spherical bearing, continue with [step 1.5](#).
- 1.5 Do a check of the axial play of the spherical bearing in the housing (1) of the lag damper (2). Obey the instructions that follow:
 - 1.5.1 Install the [Support assy, dial gauge \(T/R damper blade side\) \(GF-54-07\)](#) on the blade damper attachment (5).
 - 1.5.2 Connect the [Support arm, dial gauge \(GF-54-10\)](#) to the [Support assy, dial gauge \(T/R damper blade side\) \(GF-54-07\)](#).
 - 1.5.3 Lock the [Dial gauge \(GF-54-08\)](#) with the [Extension, dial gauge \(GF-54-09\)](#) on the end of the [Support arm, dial gauge \(GF-54-10\)](#).
Note
Make sure that you put the plunger of the dial gauge extension in the center of the surface A (lag damper body end) and perpendicular to that surface as much as possible. To get an aid to put the plunger correctly in position, refer to the adjacent bolt axle to put the plunger as much as possible parallel to that axle.
 - 1.5.4 Put the plunger of the dial gauge extension against the Surface A of the lag damper (2). Refer to Detail B of [Figure 1](#).
 - 1.5.5 Measure and record the axial play of the spherical bearing. The maximum permitted axial play is 0.1 mm (0.004 in).
 - 1.5.6 Do [step 1.5.5](#) again for two more times.
 - 1.5.7 If the three values of the axial play you recorded are in the specified limit, remove the support equipment from tail rotor head and continue with [step 2](#).

- 1.5.8 If one (or more than one) of the three values of the axial play you recorded is more than the specified limit, continue with [step 3.1](#).
- 2 Do a check of the axial play of the spherical bearing in the rod end (3) of the lag damper (2). Obey the instructions that follow:
- 2.1 Install the [Support assy, dial gauge \(sciss./swash. T/R damper hub side\) \(GF-54-04\)](#) on the hub (4).
- 2.2 Connect the [Support arm, dial gauge \(GF-54-10\)](#) to the [Support assy, dial gauge \(sciss./swash. T/R damper hub side\) \(GF-54-04\)](#) .
- 2.3 Lock the [Dial gauge \(GF-54-08\)](#) with the [Extension, dial gauge \(GF-54-09\)](#) on the end of the [Support arm, dial gauge \(GF-54-10\)](#) .
- Note**
Make sure that you put the plunger of the dial gauge extension in the center of the surface B (lag damper collar) and perpendicular to that surface as much as possible. To get an aid to put the plunger correctly in position, refer to the adjacent bolt axle to put the plunger as much as possible parallel to that axle.
- 2.4 Put the plunger of the dial gauge extension against the Surface B of the lag damper (2). Refer to Detail B of [Figure 1](#) .
- 2.5 Measure and record the axial play of the spherical bearing. The maximum permitted axial play is 0.1 mm (0.004 in).
- 2.6 Do [step 2.5](#) again for two more times.
- 2.7 If the three values of the axial play you recorded are in the specified limit, remove the support equipment from tail rotor head and continue with [step 4](#).
- 2.8 If one (or more than one) of the three values of the axial play that you recorded is more than the specified limit, continue with [step 3.1](#).
- 3 Detailed inspection on removed lag damper.
- 3.1 Remove the lag damper (1, [Figure 2](#)) from the helicopter. Refer to [39-A-64-21-02-00A-520A-A](#).
- 3.2 Put the lag damper (1) on an applicable work table.
- 3.3 Examine the two spherical bearings of the lag damper (1) for fretting, corrosion, loss of liner parts, displacement or rotation in their housings.
- 3.3.1 If you find damage to one of the two spherical bearings, send the lag damper to the Manufacturer for the replacement of the damaged spherical bearing (or bearings).
- 3.3.2 If you do not find damage to the spherical bearings, continue with [step 3.4](#).
- 3.4 Do a check of the axial play of the spherical bearing (2). Obey the instructions that follow:
-

- 3.4.1 Get an hexagon head bolt with a head flat surface and a maximum diameter of the threaded portion of 11 mm (0.4 in). Get also the related nut. Use the hexagon head bolt and the nut to do the subsequent [step 3.4.2](#).
- 3.4.2 Put the hexagon head bolt (5) into the hole of the spherical bearing (2). Lock the bolt (5) in its position with the nut (4). Tighten the nut (4) with your hands.
- 3.4.3 Lock the spherical bearing (3) in a vice with protective padded jaws.
- 3.4.4 Put the [V-block \(ZZ-00-00\)](#) (7) below the body of the lag damper (1).

Note

Make sure that you put the plunger of the dial gauge (6) in the center of the bolt head surface and perpendicular to that surface as much as possible.

- 3.4.5 Put the plunger of the [Dial gauge \(ZZ-00-00\)](#) (6) against the head of the bolt (5).
- 3.4.6 Measure and record the axial play of the spherical bearing (2). The maximum permitted axial play is 0.1 mm (0.004 in).
- 3.4.7 If the axial play is in the specified limit:
 - 3.4.7.1 Remove the nut (4) and the hexagon head bolt (5) from the spherical bearing (2).
 - 3.4.7.2 Remove the lag damper (1) from the vice and the V-block.
 - 3.4.7.3 Continue with [step 3.5](#).
- 3.4.8 If the axial play is more than the specified limit:
 - 3.4.8.1 Send the lag damper to the Manufacturer for the replacement of the damaged spherical bearing (2).
 - 3.4.8.2 Continue with [step 3.6](#).

- 3.5 Do a check of the axial play of the spherical bearing (3) of the lag damper (1). Obey the instructions that follow:
 - 3.5.1 Put the hexagon head bolt (5) into the hole of the spherical bearing (3). Lock the bolt (5) in its position with the nut (4). Tighten the nut (4) with your hands.
 - 3.5.2 Lock the spherical bearing (2) in a vice with protective padded jaws.
 - 3.5.3 Put the [V-block \(ZZ-00-00\)](#) (7) below the body of the lag damper (1).

Note

Make sure that you put the plunger of the dial gauge (6) in the center of the bolt head surface and perpendicular to that surface as much as possible.

- 3.5.4 Put the plunger of the [Dial gauge \(ZZ-00-00\)](#) (6) against the head of the bolt (5) in the spherical bearing (3).
- 3.5.5 Measure and record the axial play of the spherical bearing (3). The maximum permitted axial play is 0.1 mm (0.004 in).
- 3.5.6 If the axial play is in the specified limit:
 - 3.5.6.1 Remove the nut (4) and the hexagon head bolt (5) from the spherical bearing (3).
 - 3.5.6.2 Remove the lag damper (1) from the vice and the V-block.
 - 3.5.6.3 Continue with [step 3.6](#).
- 3.5.7 If the axial play is more than the specified limit:
 - 3.5.7.1 Replace the rod end with the damaged spherical bearing (3). Refer to [39-A-64-21-02-01A-921A-B](#).
 - 3.5.7.2 Continue with [step 3.6](#).
- 3.6 Install the lag damper on the tail rotor (if necessary, use a new lag damper). Refer to [39-A-64-21-02-00A-720A-A](#).
- 4 Do [step 1.2](#) thru [step 3.6](#) for the other three lag dampers.

Requirements After Job Completion

No Requirements After Job Completion

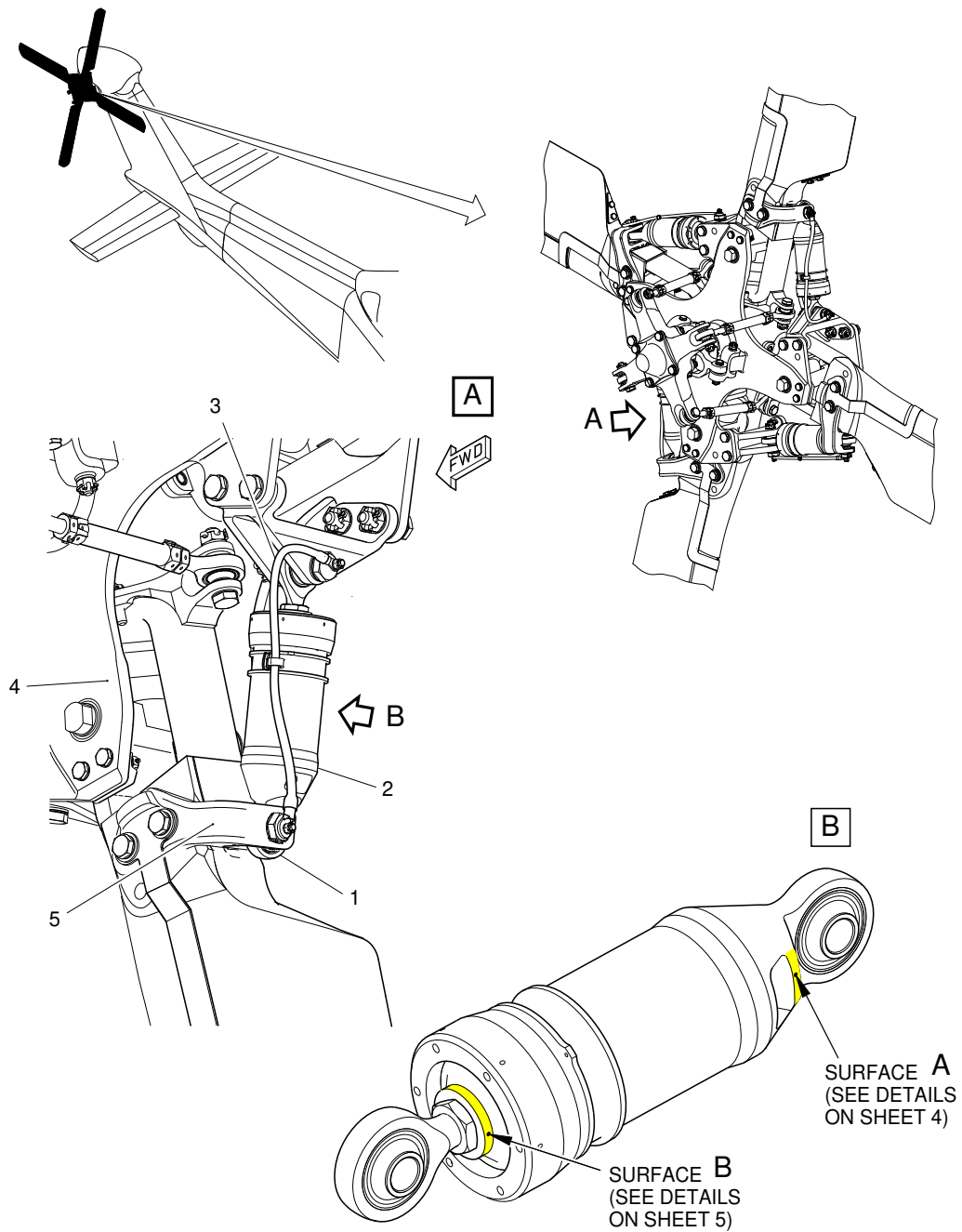

ICN-39-A-642100-G-00001-03673-A-005-01

Figure 1 (Sheet 1 of 5) Tail rotor head installation - Lag damper spherical bearings - Detailed inspection on installed lag damper



HOW TO INSTALL THE DIAL GAUGE SUPPORT
(T/R DAMPER BLADE SIDE) CORRECTLY TO DO
MEASUREMENT ON THE SURFACE A

ICN-39-A-642100-G-00001-39616-A-001-01

Figure 1 (Sheet 2 of 5) Tail rotor head installation - Lag damper spherical bearings - Detailed inspection on installed lag damper

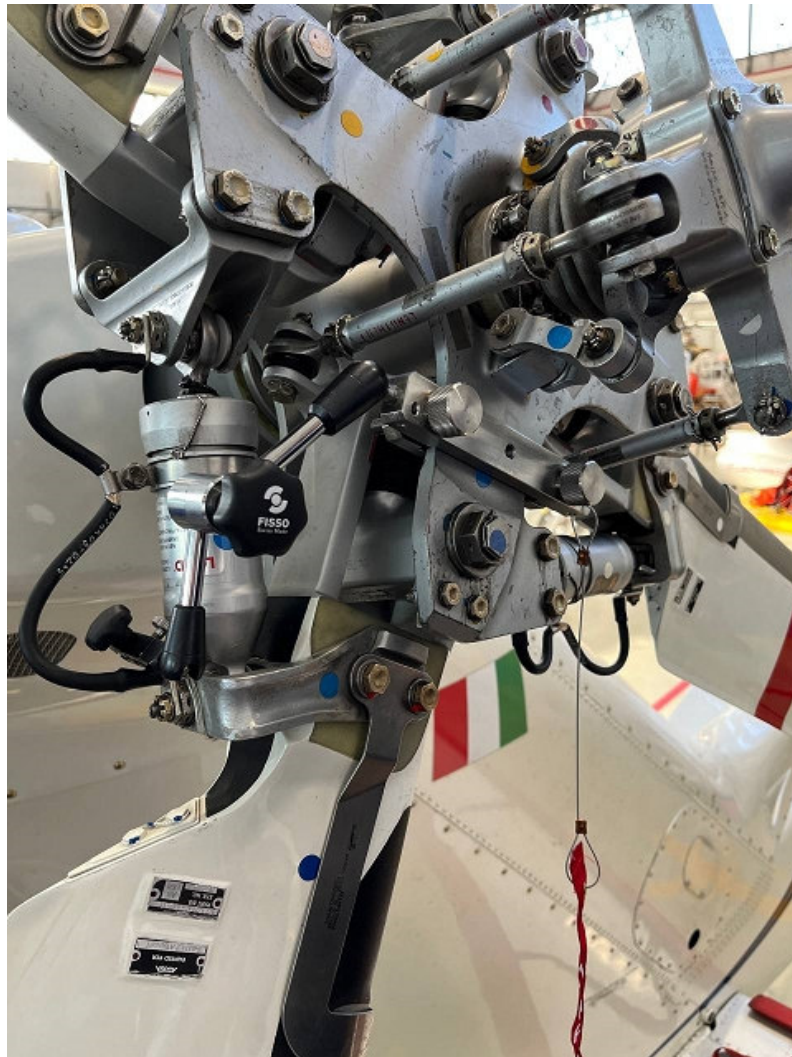

HOW TO INSTALL THE DIAL GAUGE SUPPORT
(T/R DAMPER HUB SIDE) CORRECTLY TO DO
MEASUREMENT ON THE SURFACE B

ICN-39-A-642100-G-00001-39617-A-001-01

Figure 1 (Sheet 3 of 5) Tail rotor head installation - Lag damper spherical bearings - Detailed inspection on installed lag damper



CORRECT POSITION OF THE PLUNGER ON THE SURFACE A

ICN-39-A-642100-G-00001-39615-A-001-01

Figure 1 (Sheet 4 of 5) Tail rotor head installation - Lag damper spherical bearings - Detailed inspection on installed lag damper



CORRECT POSITION OF THE PLUNGER ON THE SURFACE B

ICN-39-A-642100-G-00001-39614-A-001-01

Figure 1 (Sheet 5 of 5) Tail rotor head installation - Lag damper spherical bearings - Detailed inspection on installed lag damper

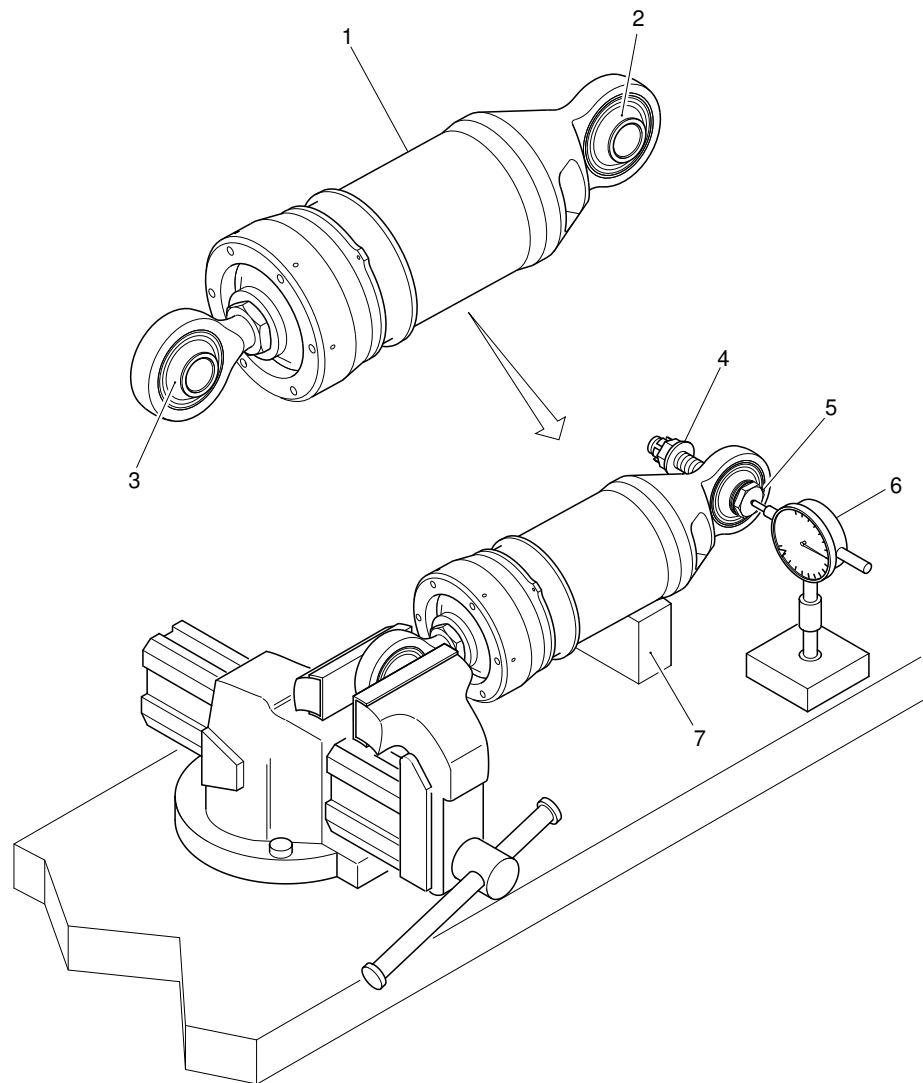

ICN-39-A-642100-G-00001-03708-A-002-01

Figure 2 Tail rotor head installation - Lag damper spherical bearings - Detailed inspection on removed lag damper

THIS PAGE INTENTIONALLY LEFT BLANK