

Temporary Maintenance Instruction TMI 139-539

Long term storage (only gearboxes) - Preservation procedure

AW139 S/N 31799

The technical content of this document is approved under the authority of DOA nr. EASA.21J.005.

The present TMI will be evaluated for its introduction in the standard set of Technical Publication.

If no further notice is received, the present document expires on: February, 15th 2022.

2021-02-15

Introduction

This TMI provides the instructions and requirements to perform the preservation procedures of the Gearboxes with relation to the helicopter s/n 31799.

Long term storage (only gearboxes) - Preservation procedure

Table of contents

References	1
Preliminary requirements	3
Procedure	4
Requirements After Job Completion	13

List of tables

1 References	1
2 Access points	2
3 Zones	2
4 Required Conditions	3
5 Support Equipment	3
6 Supplies	3
7 Spares	4

List of figures

1 Long term storage (only gearboxes) - Preservation of MGB (Sheet 1 of 4)	14
1 Long term storage (only gearboxes) - Preservation of MGB (Sheet 2 of 4)	15
1 Long term storage (only gearboxes) - Preservation of MGB (Sheet 3 of 4)	16
1 Long term storage (only gearboxes) - Preservation of MGB (Sheet 4 of 4)	17
2 Long term storage (only gearboxes) - Build-up of MGB drive motor and adapter flange	18
3 Long term storage (only gearboxes) - Preservation of IGB	19
4 Long term storage (only gearboxes) - Preservation of TGB	20

References

Table 1 References

Data Module	Title
39-A-00-20-00-00A-120A-A	Helicopter safety - Pre-operation (make helicopter safe for maintenance)
39-A-10-33-00-00A-810A-A	Long term storage - Preservation procedure
39-A-12-11-03-00A-212A-A	Main gearbox - Fill with oil
39-A-12-11-04-00A-212A-A	Intermediate gearbox - Fill with oil
39-A-12-11-05-00A-212A-A	Tail gearbox - Fill with oil
39-A-12-12-04-00A-222A-A	Main gearbox - Drain oil
39-A-12-12-05-00A-222A-A	Intermediate gearbox - Drain oil
39-A-12-12-06-00A-222A-A	Tail gearbox - Drain oil
39-A-20-00-00-00A-69CA-A	Assembled parts - Slippage Marks
39-A-29-11-02-00A-520A-A	Number 1 pump - Remove procedure
39-A-29-11-02-00A-720A-A	Number 1 pump - Install procedure
39-A-29-12-02-00A-520A-A	Number 2 pump - Remove procedure
39-A-29-12-02-00A-720A-A	Number 2 pump - Install procedure
39-A-29-12-03-00A-520A-A	Number 4 pump - Remove procedure
39-A-29-12-03-00A-720A-A	Number 4 pump - Install procedure
39-A-62-11-01-00A-520A-A	Main rotor blade - Remove procedure

Table 2 Access points

Access Panel / Door Id	Data Module
No Access Point	

Table 3 Zones

Access Panel / Door Id	Data Module
No Zones	

Preliminary Requirements

Required Conditions

Table 4 Required Conditions

Conditions	Data Module/Technical Publication
The helicopter must be safe for maintenance	39-A-00-20-00-00A-120A-A
The access panels/doors 310AL, 313AL, 360AT, 360CT and 473AL must be removed/opened	39-A-06-41-00-00A-010A-A
The main rotor blades must be removed	39-A-62-11-01-00A-520A-A

Support Equipment

Table 5 Support Equipment

Nomenclature	Identification No.	Qty
Platform, left	GG-01-00	1
Platform, right	GG-02-00	1
Wooden support	ZZ-00-00	2
Cover kit, MGB	FB-06-00	1
MGB preservation tool kit	GJ-34-00	1
Threaded rod (M8Jx1.0)	ZZ-00-00	1

Supplies

Table 6 Supplies

Nomenclature	Identification No.	Qty
Corrosion inhibitor	C272	AR
Oil	C007	AR
Lint-free cloth	C011	AR
Corrosion preventative	C132	AR
Aliphatic naphtha	C059	AR
Corrosion inhibitor remover	C273	AR
Oil	C366	AR
Oil	C548	AR
Grease	C115	AR

Spares

Table 7 Spares

Nomenclature	Identification No.	Qty
Packing	MS29561-019	4
Packing	M83248/1-116	2
Packing	M83248/1-120	2

Safety Conditions

WARNING

The materials that follow are dangerous. Before you do this procedure, make sure that you know all the safety precautions and first aid instructions for these materials:

- Corrosion inhibitor (C272)
- Oil (C007)
- Corrosion preventative (C132)
- Corrosion inhibitor remover (C273)
- Aliphatic naphtha (C059)
- Oil (C366)
- Oil (C548) .

CAUTION

If necessary, for the long-term storage precautions on the helicopter not given here, refer to [39-A-10-33-00-00A-810A-A](#).

Procedure

CAUTION

During the procedure that follow obey the subsequent precautions:

- Put the removed components in their applicable containers or available plastic bags
- Put the removed attach parts in separate bags. Take a note on each bag to identify the component from which the attach parts was removed. Make sure that the attach parts are protected against corrosion
- Temporarily put each component container or plastic bag, complete with the bag of its attach part in an available clear place inside the helicopter cabin.

1 **General**

This data module gives you the data that is necessary when you must put the installed gearboxes into storage condition.

Unless differently specified, these data applies to:

- The main gearbox
- The intermediate gearbox

- The tail gearbox.

Note

1. Always record in the Aircraft Log Book the date and the type of storage.
2. The storage of the gearboxes has no effect on the Discard and Overhaul calendar time intervals. Obey the applicable intervals while the gearboxes are in storage.
3. During the preservation procedure and storage time, you must not do the calendar preventive maintenance tasks. Thus the time interval counter must stop in this period.

1.1 You must continue to do the preservation procedure without stops between operations. If this occurs, apply temporary protections on the parts and components to prevent their contamination.

1.2 Put the [Platform, left \(GG-01-00\)](#) and [Platform, right \(GG-02-00\)](#) adjacent to the right and left sides of the fuselage.

2 Preservation of the Main Gearbox (MGB)

2.1 Remove the Number 1 pump. Refer to [39-A-29-11-02-00A-520A-A](#).

2.2 Remove the Number 2 pump. Refer to [39-A-29-12-02-00A-520A-A](#).

2.3 Remove the Number 4 pump. Refer to [39-A-29-12-03-00A-520A-A](#). Do not apply protective cover or plugs on the drive quill port of the Number 4 pump on the MGB.

2.4 Lubricate the new [Packing \(MS29561-019\)](#) (11, [Figure 1](#)) and (8) with the [Grease \(C115\)](#) , then install them on the plugs (12) and (7) (part of [MGB preservation tool kit \(GJ-34-00\)](#)).

2.5 Put the plugs (12) and (7) into the drive quills of the Number 2 pump and Number 1 pump as follow:

2.5.1 To make this operation easier, install the [Threaded rod \(M8Jx1.0\) \(ZZ-00-00\)](#) into the hole on the top of the plugs (12) and (7).

2.5.2 Use the threaded rod to push the plugs (12) and (7) into the drive quills of the Number 2 pump and Number 1 pump respectively.

2.5.3 Remove the threaded rod from the plugs.

2.6 Attach the cover (3) (part of the [Cover kit, MGB \(FB-06-00\)](#)) on the flange (10) of the Number 2 pump with the four washers (2) and the four nuts (1). Use the attaching parts supplied with the cover.

2.7 Tighten the four nuts (1).

2.8 Install the cover (6) (part of the [Cover kit, MGB \(FB-06-00\)](#)) on the flange (9) of the Number 1 pump with the four washers (5) and the four nuts (4). Use the attaching parts supplied with the cover.

2.9 Tighten the four nuts (4).

- 2.10 Get access to the forward end side of the Number 1 drive shaft (13).
- 2.11 Put the [Wooden support \(ZZ-00-00\)](#) below the Number 1 drive shaft (13). Put it in a position near the forward end of the Number 1 drive shaft (13). This is to hold the drive shaft weight during the disconnection from the MGB sliding adaptor (18).
- 2.12 Remove these parts that attach the Number 1 flexible coupling (16) to the MGB sliding adaptor (18):
- The five self locking nuts (14)
 - The five washers (15)
 - The five bolts (17).
- 2.13 Hold the forward end of the Number 1 drive shaft (13) with your hands.

CAUTION

Do not use a metallic lever to disengage the Number 1 flexible coupling (16) from the MGB sliding adaptor (18).

- 2.14 Lightly and carefully move the Number 1 drive shaft (13) in the aft direction to disengage it from the MGB sliding adaptor (18). Make sure that the Number 1 flexible coupling (16) and the MGB sliding adaptor (18) cannot touch each other.
- 2.15 Get access to the Number 1 drive shaft (19) of the Number 1 engine.
- 2.16 Remove the six nuts (21) and the six bolts (20) that attach the Number 1 drive shaft (19) to the flange (22) of the Number 1 input-shaft module.

CAUTION

Do not use a metallic lever to disengage the Number 1 drive shaft (19) from the flange (22).

- 2.17 Lightly and carefully move the Number 1 drive shaft (19) in the aft direction to disengage it from the flange (22) of the Number 1 input-shaft module. Make sure that the Number 1 drive shaft (19) and the flange (22) cannot touch each other.
- 2.18 Get access to the Number 2 drive shaft of the Number 2 engine on the right side.
- 2.19 Do the same procedure given in the [step 2.16](#) and [step 2.17](#) to disconnect the Number 2 drive shaft from the related flange of the Number 2 input-shaft module.
- 2.20 Install the electric motor (part of [MGB preservation tool kit \(GJ-34-00\)](#)) on the MGB. Obey the instructions that follows:

Note

Do [step 2.20.1](#) thru [step 2.20.7](#) on an applicable work table.

- 2.20.1 Put the spacer (2, [Figure 2](#)) into the driving shaft (1).
- 2.20.2 Install the driving shaft (1) and the key (4) on the shaft of the electric motor (3).

- 2.20.3 Safety the driving shaft (1) on the shaft of the electric motor (3) with the two set screws (5).
 - 2.20.4 Lubricate the packing (6) with the [Grease \(C115\)](#) then install it on the driving shaft (1).
 - 2.20.5 Lubricate the splines of the driving shaft (1) with the [Grease \(C115\)](#) .
 - 2.20.6 Put the centering ring (8) against the adapter flange (9).
 - 2.20.7 Install the four screws (7) that attach the centering ring (8) to the adapter flange (9).
 - 2.20.8 Put the adapter flange assembly (31, [Figure 1](#)) in its correct position on the flange (28) of the Number 4 hydraulic-pump drive quill.
 - 2.20.9 Install the four washers (29) and the four nuts (30) that attach the adapter flange assembly (31) to the flange (28).
 - 2.20.10 Carefully put the electric motor assembly (23) in its correct position on the adapter flange assembly (31) and aligns the mounting holes.
 - 2.20.11 Carefully move the electric motor assembly (23) until its flange is against the adapter flange assembly (31) and the splines of the driving shaft are fully engaged with the splines of the Number 4 hydraulic-pump drive quill.
 - 2.20.12 Install the four washers (26), the four screws (27), the four washers (25) and the four nuts (24) that attach the electric motor assembly (23) to the adapter flange assembly (31).
 - 2.21 Drain oil from the main gearbox. Refer to [39-A-12-12-04-00A-222A-A](#).
 - 2.22 In an applicable container you must prepare a total of 20.00 dm³ (5.28 US gals) of preservation mixture for the MGB. Prepare a mixture of 19 dm³ (5.019 US gals) of the [Oil \(C548\)](#) or the [Oil \(C007\)](#) or the [Oil \(C366\)](#) and 1 dm³ (0.264 US gals) of the [Corrosion preventative \(C132\)](#) .
 - 2.23 Fill the MGB with the prepared preservation mixture. Refer to the applicable steps in the data module [39-A-12-11-03-00A-212A-A](#).
 - 2.24 Put the electric board (32) (part of [MGB preservation tool kit \(GJ-34-00\)](#)) adjacent to the electric motor (23) installed on the MGB.
 - 2.25 Connect the power cable of the electric motor (23) to the electrical board (32).
 - 2.26 Connect the power cable of the electrical board (32) to a 380 V, 50/60 Hz power supply.
- Note**
Do a check of the electric motor speed on the display of the electrical board (32).
- 2.27 Start the electric motor and gradually increase its speed to 2300 thru 2500 revolutions per minute (RPM). Make sure that the main rotor hub turns counterclockwise.
 - 2.28 After approximately 5 minutes, stop the electric motor.
-

-
- 2.29 Let all the preservation mixture drain into the MGB oil sump. This occurs approximately after a time approximately of 15 minutes.
- 2.30 Drain the preservation mixture from the MGB. Refer to the applicable steps of the data module [39-A-12-12-04-00A-222A-A](#).
- 2.31 Disconnect the power cable of the electrical board (32) from the 380 V, 50/60 Hz power supply.
- 2.32 Disconnect the power cable of the electric motor (23) from the electrical board (32).
- 2.33 Attach a warning tag to the oil filler neck of the MGB. This is to tell the personnel that the MGB has an internal protection with the preservation mixture and do not contain oil.
- 2.34 Remove the four nuts (4) and the four washers (5) that attach the cover (6) to the flange (9) of the Number 1 pump. Put the supplied attaching parts in the [Cover kit, MGB \(FB-06-00\)](#) container.
- 2.35 Remove the cover (6) from the flange (9) of the Number 1 pump. Put the cover (6) in the [Cover kit, MGB \(FB-06-00\)](#) .
- 2.36 Remove the four nuts (1) and the four washers (2) that attach the cover (3) to the flange (10) of the Number 2 pump. Put the supplied attaching parts in the [Cover kit, MGB \(FB-06-00\)](#) container.
- 2.37 Remove the cover (3) from the flange (10) of the Number 2 pump. Put the cover (3) in the [Cover kit, MGB \(FB-06-00\)](#) .
- 2.38 Remove the plug (7) from the Number 1 hydraulic-pump drive-quill as follows:
- 2.38.1 To make this operation easy, install the [Threaded rod \(M8Jx1.0\) \(ZZ-00-00\)](#) into the hole on the top of the plug (7).
- 2.38.2 Use the threaded rod to pull the plug (7) out of the Number 1 hydraulic-pump drive-quill.
- 2.38.3 Remove the threaded rod from the plug (7).
- 2.38.4 Remove the two packings (8) from the plug (7). Discard the packings.
- 2.39 Do the [step 2.38](#) for the plug (12) of the Number 2 hydraulic-pump drive-quill.
- 2.40 Install the Number 1 pump. Refer to [39-A-29-11-02-00A-720A-A](#).
- 2.41 Install the Number 2 pump. Refer to [39-A-29-12-02-00A-720A-A](#).
- 2.42 **Operations after MGB preservation**
- 2.42.1 Remove the electric motor assembly (23) and the adapter flange assembly (31) from the MGB. Obey the instructions that follow:
- 2.42.1.1 Remove the four nuts (24) and the four washers (25) that attach the electric motor assembly (23) to the adapter flange assembly (31).
-

- 2.42.1.2 Carefully move the electric motor assembly (23) from the adapter flange assembly (31) until the driving shaft is out of it.
- 2.42.1.3 Put the electric motor assembly (23) on an applicable work table.
- 2.42.1.4 Remove the four nuts (30) and the four washers (29) that attach the adapter flange assembly (31) to the flange (28) of the Number 4 hydraulic-pump drive-quill.
- 2.42.1.5 Remove the adapter flange assembly (31) from the flange (28).
- 2.42.1.6 Put the adapter flange assembly (31) on the work table.
- 2.42.1.7 Disassemble the adapter flange assembly (31) and the electric motor assembly (23). Obey the instructions that follow:
 - 2.42.1.7.1 Remove the four screws (7, [Figure 2](#)) that attach the centering ring (8) to the adapter flange (9).
 - 2.42.1.7.2 Remove the centering ring (8) from the adapter flange (9).
 - 2.42.1.7.3 Remove the packing (6) from the driving shaft (1).
 - 2.42.1.7.4 Remove the two set screws (5) from the driving shaft (1).
 - 2.42.1.7.5 Remove the driving shaft (1) and the key (4) from the shaft of the electric motor (3).
 - 2.42.1.7.6 Remove the spacer (2) from the driving shaft (1).
- 2.42.2 Put the disassembled parts in the related [MGB preservation tool kit \(GJ-34-00\)](#) container. Keep the items of the MGB preservation tool kit apart to use them again when necessary.
- 2.43 Install the Number 4 pump. Refer to [39-A-29-12-03-00A-720A-A](#).
- 2.44 Get access to the forward end side of the Number 1 drive shaft (13).
- 2.45 Attach the Number 1 drive shaft (13) to the MGB sliding adaptor (18) as follows:
 - 2.45.1 Clean the mating surface between the Number 1 drive shaft (13) and the MGB sliding adaptor (18) with the [Lint-free cloth \(C011\)](#) and the [Aliphatic naphtha \(C059\)](#) or the [Corrosion inhibitor remover \(C273\)](#). Dry this surface with a clean cloth.

Note

Mask the applicable surrounding area where you must not apply the corrosion inhibitor.
 - 2.45.2 Apply the [Corrosion inhibitor \(C272\)](#) on the mating surface between the Number 1 drive shaft (13) and the MGB sliding adaptor (18). Use the applicable clean brush or a spray gun. Make sure that you apply the corrosion inhibitor on the mating surface equally.
 - 2.45.3 Let the corrosion inhibitor dry for a time of 30 minutes minimum at ambient temperature.

-
- 2.45.4 Carefully move the Number 1 drive shaft (13) in the forward direction to engage it to the MGB sliding adaptor (18). Make sure that the holes of the drive shaft (13) and the sliding adaptor (18) are aligned.
- 2.45.5 Attach the Number 1 drive shaft (13) to the MGB sliding adaptor (18) with these parts:
- The five bolts (17)
 - The five washers (15)
 - The five self locking nuts (14).
- Make sure that the head of the bolts (17) are against the MGB sliding adaptor (18).
- 2.45.6 Torque the five self locking nuts (14) to 22.56 thru 24.88 N m (199.65 thru 220.20 lbf in) in the cross sequence.
- 2.45.7 Apply the slippage marks between the body of the nuts (14) and the related washers. Refer to [39-A-20-00-00-00A-69CA-A](#). This is to get a necessary indication of unwanted loose nuts.
- 2.46 Remove the wooden support from below the Number 1 drive shaft (13).
- 2.47 Get access to the Number 1 drive shaft (19) of the Number 1 engine.
- 2.48 Connect the Number 1 drive shaft (19) to the flange (22) of the Number 1 input-shaft module.
- 2.49 Attach the Number 1 drive shaft (19) to the flange (22) of the Number 1 input-shaft module with the six bolts (20) and the six nuts (21).
- 2.50 Torque the six nuts (21) to 10.75 thru 12.15 N m (95.13 thru 107.52 lbf in) in the cross sequence.
- 2.51 Get access to the Number 2 drive shaft of the Number 2 engine on the right side.
- 2.52 Do the same procedure given in the [step 2.48](#) thru [step 2.50](#) to connect the Number 2 drive shaft to the related flange of the Number 2 input-shaft module.
- 3 Preservation of the Intermediate Gearbox (IGB)**
- 3.1 Put the [Platform, right \(GG-02-00\)](#) adjacent to the right side of the tail section.
- 3.2 Get access to the aft end side of the Number 2 drive shaft (7, [Figure 3](#)) in front of the IGB (1).
- 3.3 Put the [Wooden support \(ZZ-00-00\)](#) below the Number 2 drive shaft (7). Put it in a position near the aft end of the Number 2 drive shaft (7). This is to hold the drive shaft weight during the disconnection from the IGB sliding adaptor (3).
- 3.4 Remove these parts that attach the Number 3 flexible coupling (4) to the IGB sliding adaptor (3):
- The five self locking nuts (6)
 - The five washers (5)
 - The five bolts (2).
-

3.5 Hold the aft end of the Number 2 drive shaft (7) with your hands.

CAUTION

Do not use a metallic lever to disengage the Number 3 flexible coupling (4) from the IGB sliding adaptor (3).

3.6 Lightly and carefully move the Number 2 drive shaft (7) in the forward direction to disengage it from the IGB sliding adaptor (3). Make sure that the Number 3 flexible coupling (4) and the IGB sliding adaptor (3) cannot touch each other.

3.7 Drain oil from the IGB (1). Refer to [39-A-12-12-05-00A-222A-A](#).

3.8 In an applicable container you must prepare a total of 1 dm³ (0.264 US gals) of preservation mixture for the IGB. Prepare a mixture of 0.95 dm³ (0.250 US gals) of the [Oil \(C548\)](#) or the [Oil \(C007\)](#) or the [Oil \(C366\)](#) and 0.05 dm³ (0.0132 US gals) of the [Corrosion preventative \(C132\)](#) .

3.9 Fill the IGB with the prepared preservation mixture. Refer to the applicable steps in the data module [39-A-12-11-04-00A-212A-A](#).

3.10 Turn counterclockwise the tail rotor head with your hands. Do at least 10 full turn to move the internal gears of the IGB (1). This is to apply the oil mixture in all the inner parts of the IGB (1).

3.11 Drain the preservation mixture from the IGB. Refer to the applicable steps of the data module [39-A-12-12-05-00A-222A-A](#).

3.12 Attach a warning tag to the oil filler neck of the IGB. This is to tell the personnel that the IGB has an internal protection with the preservation mixture and do not contain oil.

3.13 Attach the Number 2 drive shaft (7) to the IGB sliding adaptor (3) as follows:

3.13.1 Clean the mating surface between the Number 3 flexible coupling (4) and the IGB sliding adaptor (3) with the [Lint-free cloth \(C011\)](#) and the [Aliphatic naphtha \(C059\)](#) or the [Corrosion inhibitor remover \(C273\)](#) . Dry this surface with a clean cloth.

Note

Mask the applicable surrounding area where you must not apply the corrosion inhibitor.

3.13.2 Apply the [Corrosion inhibitor \(C272\)](#) on the mating surface between the Number 3 flexible coupling (4) and the IGB sliding adaptor (3). Use the applicable clean brush or a spray gun. Make sure that you apply the corrosion inhibitor on the mating surface equally.

3.13.3 Let the corrosion inhibitor dry for a time of 30 minutes minimum at ambient temperature.

3.13.4 Carefully move the Number 2 drive shaft (7) in the aft direction to engage the Number 3 flexible coupling (4) to the IGB sliding adaptor (3). Make sure that the holes of the Number 3 flexible coupling (4) and the IGB sliding adaptor (3) are aligned.

3.13.5 Attach the Number 3 flexible coupling (4) to the IGB sliding adaptor (3) with these parts:

- The five bolts (2)
- The five washers (5)
- The five self locking nuts (6).

Make sure that the head of the bolts (2) are against the IGB sliding adaptor (3).

- 3.13.6 Torque the five self locking nuts (6) to 20.0 thru 22.0 N m (177 thru 195 lbf in) in the cross sequence.
- 3.13.7 Apply the slippage marks between the body of the five self locking nuts (6) and the related washers. Refer to [39-A-20-00-00-00A-69CA-A](#). This is to get a necessary indication of unwanted loose nuts.
- 3.13.8 Remove the wooden support from below the Number 2 drive shaft (7).

4 Preservation of the Tail Gearbox (TGB)

- 4.1 Put the [Platform, right \(GG-02-00\)](#) adjacent to the right side of the tail section near the vertical fin.

Note

You must turn the main rotor head counterclockwise when necessary. This is to get access to the attach parts of the Number 3 drive shaft (7) in the vertical fin.

- 4.2 Get access to the top end side of the Number 3 drive shaft (7, [Figure 4](#)) through the hole at the top of the vertical fin.
- 4.3 Remove these parts that attach the Number 5 flexible coupling (6) to the TGB sliding adaptor (3):
- The five self locking nuts (5)
 - The five washers (4)
 - The five bolts (2).

CAUTION

Do not use a metallic lever to disengage the Number 5 flexible coupling (6) from the TGB sliding adaptor (3).

- 4.4 Lightly and carefully lower the Number 3 drive shaft (7) to disengage it from the TGB sliding adaptor (3). Make sure that the Number 5 flexible coupling (6) and the TGB sliding adaptor (3) cannot touch each other.
- 4.5 Let the TGB sliding adaptor (3) stay in its position in the TGB (1).
- 4.6 Drain oil from the TGB. Refer to [39-A-12-12-06-00A-222A-A](#).
- 4.7 In an applicable container you must prepare a total of 1.5 dm³ (0.396 US gals) of preservation mixture for the TGB. Prepare a mixture of 1.425 dm³ (0.376 US gals) of the [Oil \(C548\)](#) or the [Oil \(C007\)](#) or the [Oil \(C366\)](#) and 0.075 dm³ (0.0198 US gals) of the [Corrosion preventative \(C132\)](#) .
- 4.8 Fill the TGB with the prepared preservation mixture. Refer to the applicable steps in the data module [39-A-12-11-05-00A-212A-A](#).
- 4.9 Turn counterclockwise the tail rotor head with your hands. Do at least 10 full turn to move the internal gears of the TGB (1). This is to apply the oil mixture in all the inner parts of the TGB (1).

- 4.10 Drain the preservation mixture from the TGB. Refer to the applicable steps of the data module [39-A-12-12-06-00A-222A-A](#).
- 4.11 Attach a warning tag to the oil filler neck of the TGB. This is to tell the personnel that the TGB has an internal protection with the preservation mixture and do not contain oil.
- 4.12 Attach the Number 3 drive shaft (7) to the TGB sliding adaptor (3) as follows:
- 4.12.1 Clean the mating surface between the Number 5 flexible coupling (6) and the TGB sliding adaptor (3) with the [Lint-free cloth \(C011\)](#) and the [Aliphatic naphtha \(C059\)](#) or the [Corrosion inhibitor remover \(C273\)](#) . Dry this surface with a clean cloth.
- Note**
Mask the applicable surrounding area where you must not apply the corrosion inhibitor.
- 4.12.2 Apply the [Corrosion inhibitor \(C272\)](#) on the mating surface between the Number 5 flexible coupling (6) and the TGB sliding adaptor (3). Use an applicable clean brush. Make sure that you apply the corrosion inhibitor on the mating surface equally.
- 4.12.3 Let the corrosion inhibitor dry for a time of 30 minutes minimum at ambient temperature.
- 4.12.4 Carefully lift the Number 3 drive shaft (7) to engage the Number 5 flexible coupling (6) to the TGB sliding adaptor (3). Make sure that the holes of the Number 5 flexible coupling (6) and the TGB sliding adaptor (3) are aligned.
- 4.12.5 Attach the Number 5 flexible coupling (6) to the TGB sliding adaptor (3) with these parts:
- The five bolts (2)
 - The five washers (4)
 - The five self locking nuts (5).
- Make sure that the head of the bolts (2) are against the TGB sliding adaptor (3).
- 4.12.6 Torque the five self locking nuts (5) to 20.0 thru 22.0 N m (177 thru 195 lbf in) in the cross sequence.
- 4.12.7 Apply the slippage marks between the body of the five self locking nuts (5) and the related washers. Refer to [39-A-20-00-00-00A-69CA-A](#). This is to get a necessary indication of unwanted loose nuts.

Requirements After Job Completion

- 1 Remove all the tools and the other items from the work area. Make sure that the work area is clean.
- 2 Install/close the access panels/doors 310AL, 313AL, 360AT, 360CT and 473AL. Refer to [39-A-06-41-00-00A-010A-A](#)
- 3 Remove the platform from the left side of the fuselage.
- 4 Remove the platform from the right side of the vertical fin.

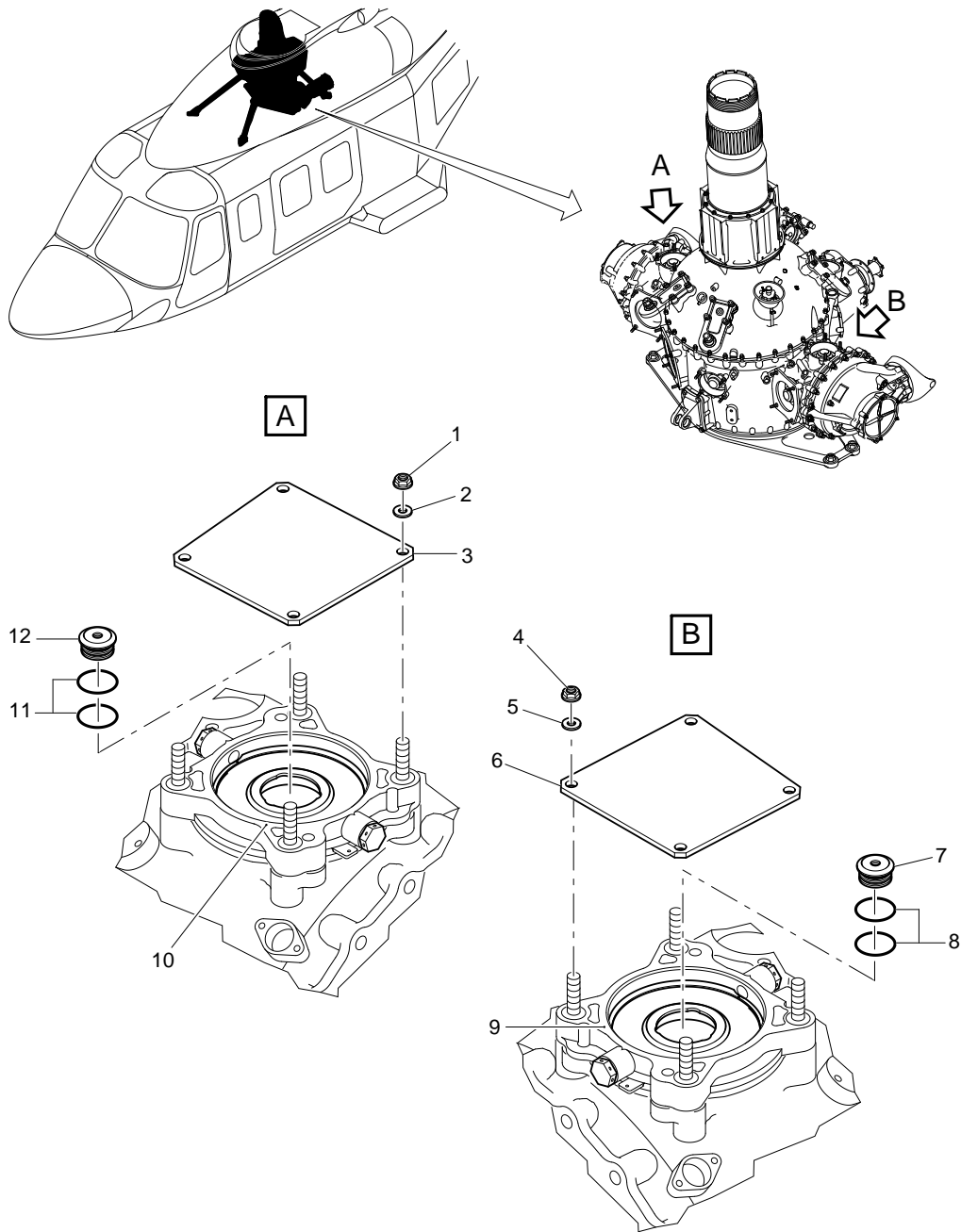

ICN-39-A-103300-G-00001-32643-A-001-01

Figure 1 (Sheet 1 of 4) Long term storage (only gearboxes) - Preservation of MGB

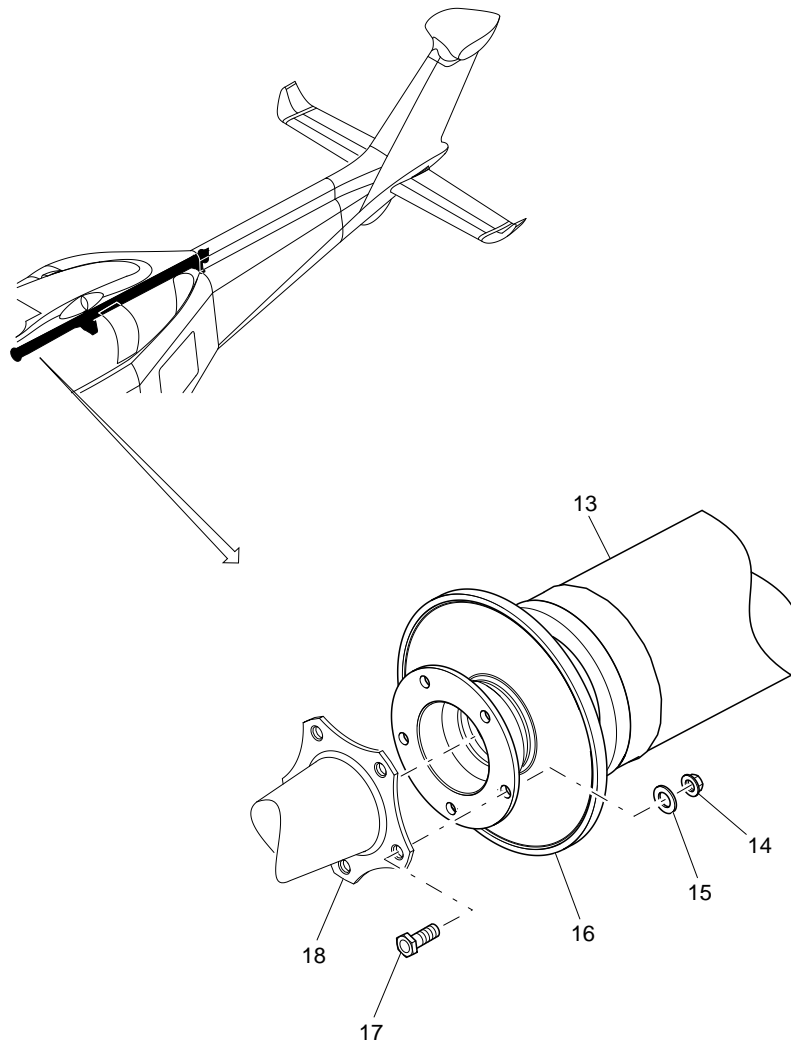

ICN-39-A-103300-G-00001-32644-A-001-01

Figure 1 (Sheet 2 of 4) Long term storage (only gearboxes) - Preservation of MGB

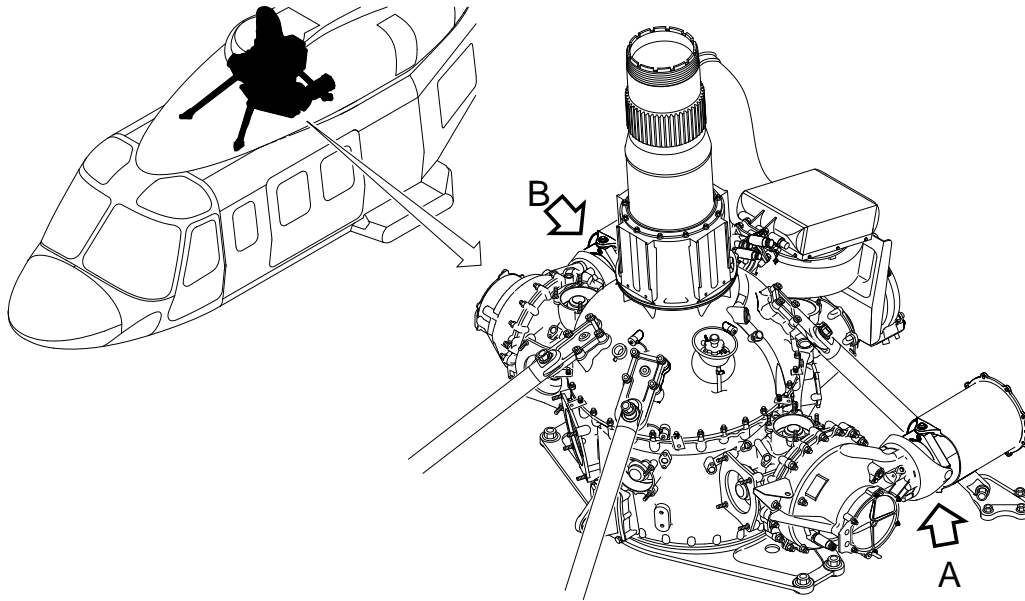

A TYPICAL FOR VIEW B

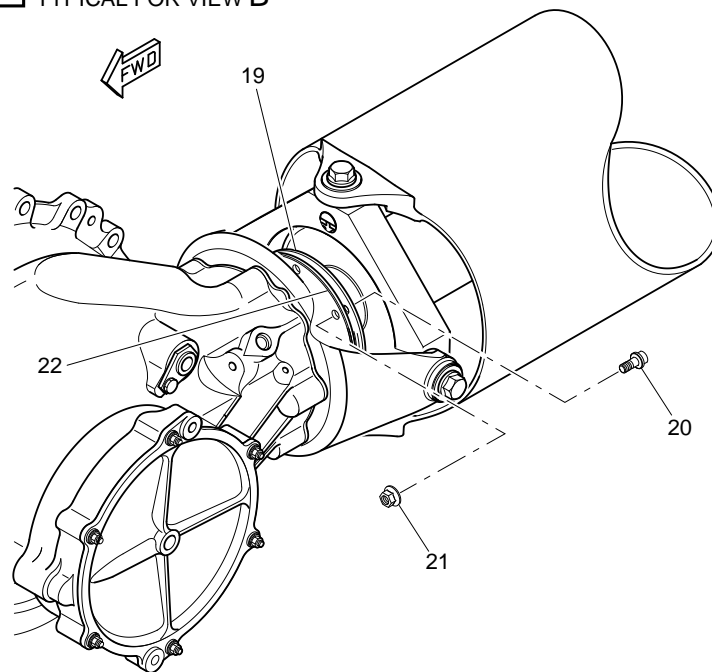

ICN-39-A-103300-G-00001-32645-A-001-01

Figure 1 (Sheet 3 of 4) Long term storage (only gearboxes) - Preservation of MGB

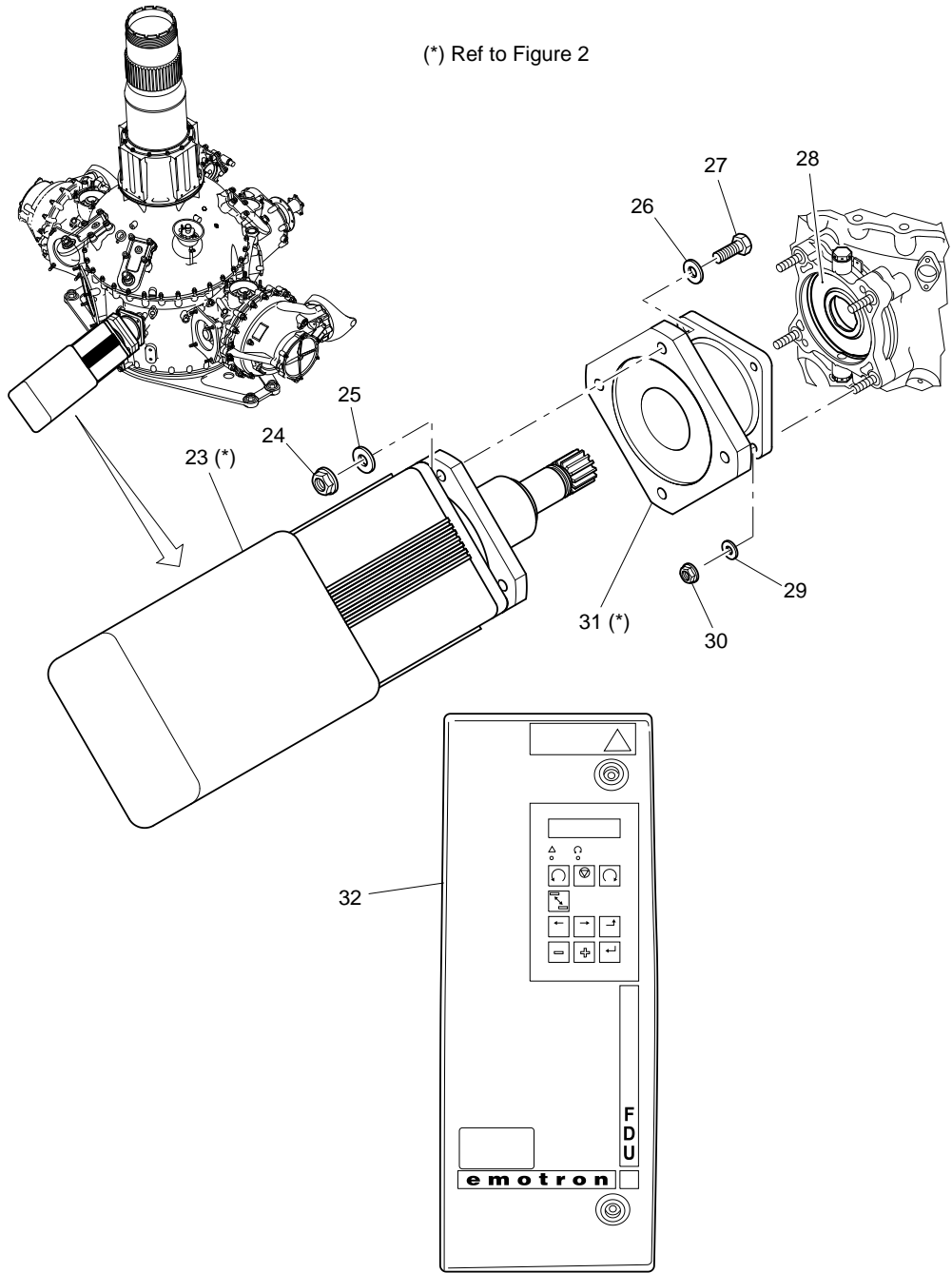

ICN-39-A-103300-G-00001-32647-A-001-01

Figure 1 (Sheet 4 of 4) Long term storage (only gearboxes) - Preservation of MGB

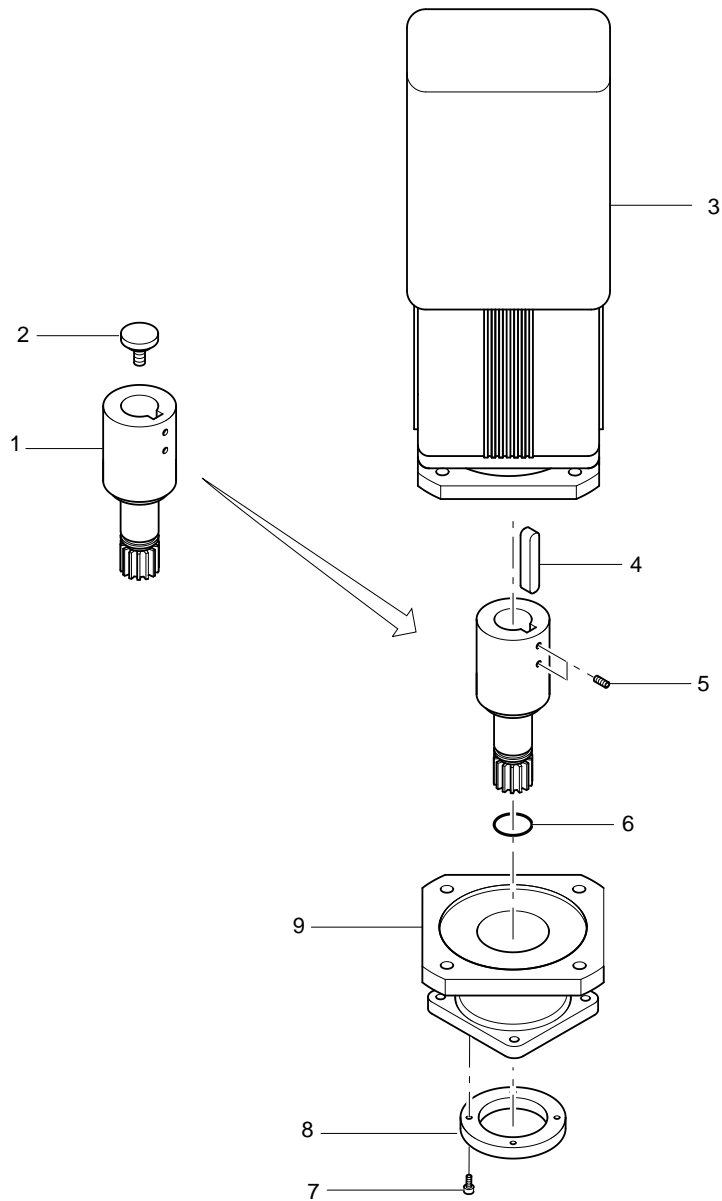

ICN-39-A-103300-G-00001-32646-A-001-01

Figure 2 Long term storage (only gearboxes) - Build-up of MGB drive motor and adapter flange

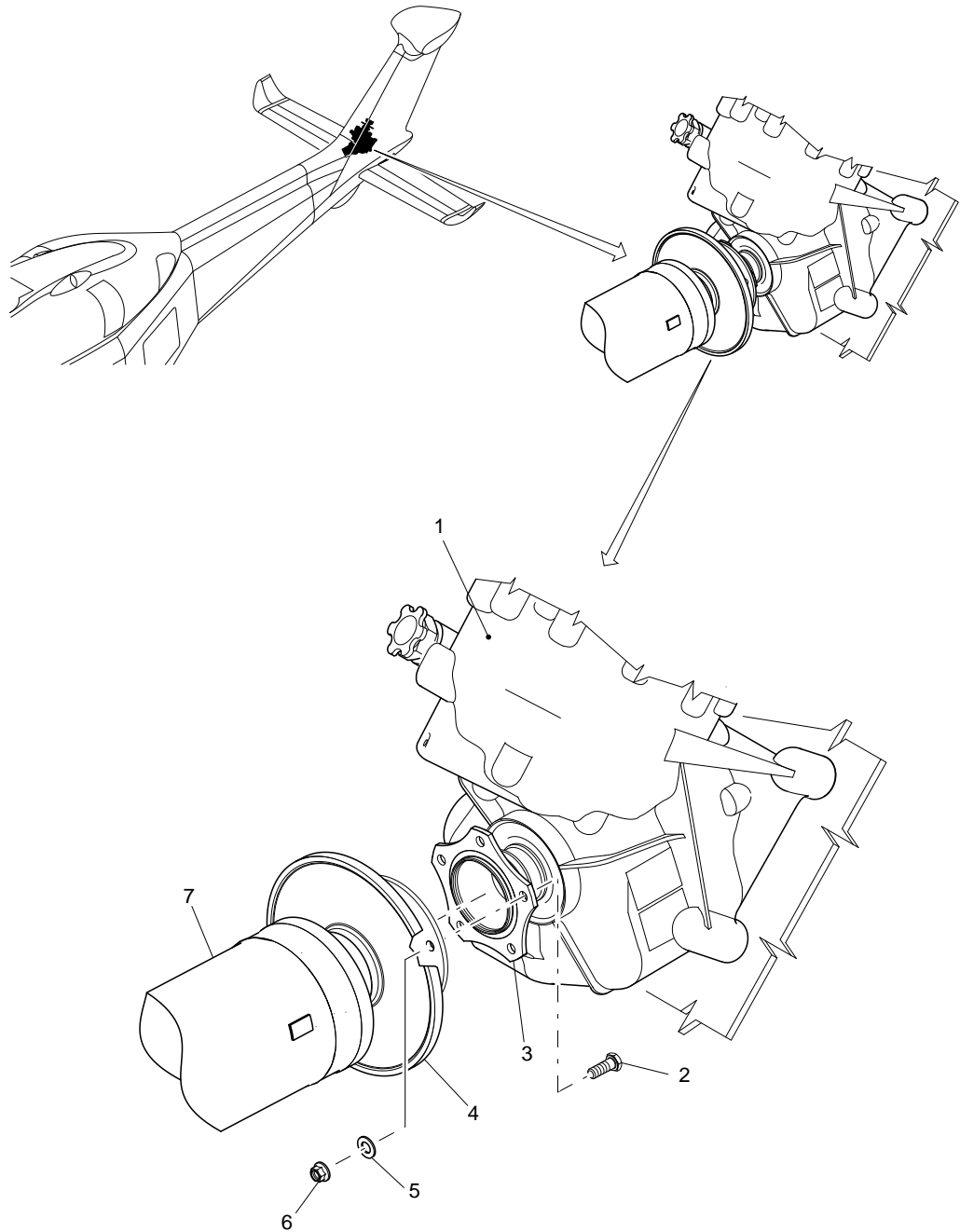

ICN-39-A-103300-G-00001-32648-A-001-01

Figure 3 Long term storage (only gearboxes) - Preservation of IGB

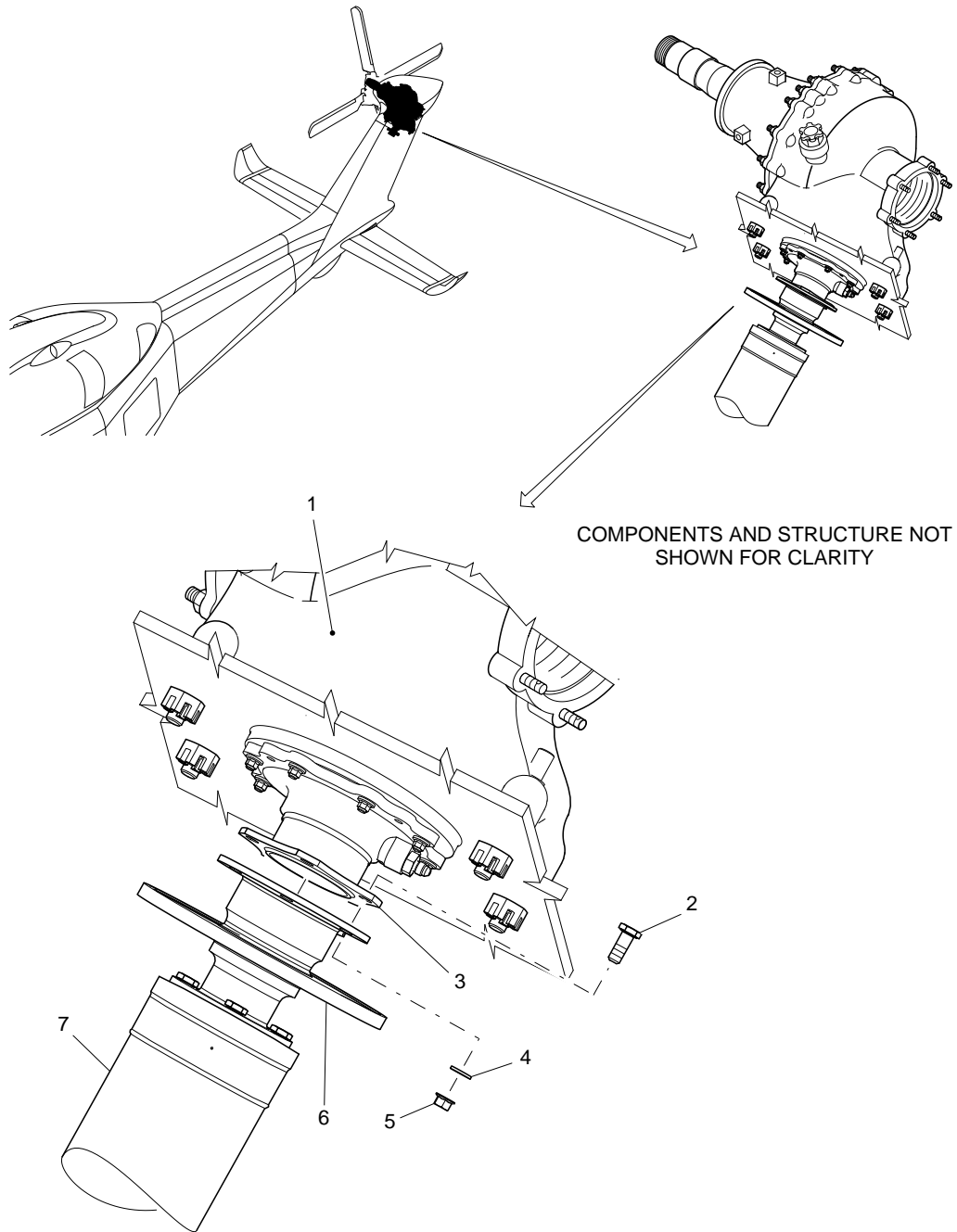

ICN-39-A-103300-G-00001-32649-A-001-01

Figure 4 Long term storage (only gearboxes) - Preservation of TGB