

## Temporary Maintenance Instruction TMI 139-429 Rev F

### Forward Lower Panel Assembly – Remove and Replace – 3P5340A01431 and 3P5340A43631

### All AW139 Helicopters

*The technical content of this document is approved under the authority of DOA nr. EASA.21J.005.*

*The present TMI will be evaluated for its introduction in the standard set of Technical Publication.*

*If no further notice is received, the present document expires on: **September 28<sup>th</sup>, 2022.***

**2021-09-28**

---

## Introduction

This TMI provides the instructions and requirements to perform the replacement of the Forward Lower Panel Assembly P/Ns: 3P5340A01431 and 3P5340A43631.

Rev. F of this TMI is published in order to extend the expiration date.

**Forward Lower Panel Assembly – Remove and Replace – 3P5340A01431 and 3P5340A43631**

**Table of contents**

References ..... 5  
 Preliminary requirements..... 6  
 Procedure ..... 9  
 Requirements after job completion..... 13  
 Annex A ..... 55

**List of tables**

1 References..... 5  
 2 Access points..... 5  
 3 Zones ..... 5  
 4 Required conditions ..... 6  
 5 Support Equipment ..... 6  
 6 Supplies ..... 7  
 7 Spares..... 8

**List of figures**

1 Work Area – Forward Left Panel Assy..... 14  
 2 Main View – Looking Inboard (Sheet 1 of 2) ..... 15  
 2 Main View Looking Inboard (Sheet 2 of 2) ..... 16  
 3 View A and Associated Views (Sheet 1 of 3) ..... 17  
 3 View A and Associated Views (Sheet 2 of 3) ..... 18  
 3 View A and Associated Views (Sheet 3 of 3) ..... 18  
 4 Section B-B and Associated Views (Sheet 1 of 6)..... 19  
 4 Section B-B and Associated Views (Sheet 2 of 6)..... 19  
 4 Section B-B and Associated Views (Sheet 3 of 6)..... 20  
 4 Section B-B and Associated Views (Sheet 4 of 6)..... 20  
 4 Section B-B and Associated Views (Sheet 5 of 6)..... 21  
 4 Section B-B and Associated Views (Sheet 6 of 6)..... 21  
 5 Section C-C and Associated Views (Sheet 1 of 4) ..... 22  
 5 Section C-C and Associated Views (Sheet 2 of 4) ..... 22  
 5 Section C-C and Associated Views (Sheet 3 of 4) ..... 23  
 5 Section C-C and Associated Views (Sheet 4 of 4) ..... 23  
 6 Detail D and Associated Views (Sheet 1 of 2)..... 24  
 6 Detail D and Associated Views (Sheet 2 of 2)..... 24  
 7 Detail E and Associated Views (Sheet 1 of 6)..... 25  
 7 Detail E and Associated Views (Sheet 2 of 6)..... 26  
 7 Detail E and Associated Views (Sheet 3 of 6)..... 27

7 Detail E and Associated Views (Sheet 4 of 6) ..... 28

7 Detail E and Associated Views (Sheet 5 of 6) ..... 29

7 Detail E and Associated Views (Sheet 6 of 6) ..... 30

8 Detail F and Associated Views (Sheet 1 of 3) ..... 30

8 Detail F and Associated Views (Sheet 2 of 3) ..... 30

8 Detail F and Associated Views (Sheet 3 of 3) ..... 31

9 Rivet Codes ..... 31

10 Clippings Installation ..... 32

11 View G1 – RH Side Wall ..... 33

12 View G2 – LH Side Wall ..... 34

13 View G3 – LH Side – Bottom ..... 35

14 View G4 – RH Side – Bottom ..... 36

15 Detail G5 – Surface Preparation ..... 37

16 Detail H and Associated Views (Sheet 1 of 5) ..... 38

16 Detail H and Associated Views (Sheet 2 of 5) ..... 39

16 Detail H and Associated Views (Sheet 3 of 5) ..... 40

16 Detail H and Associated Views (Sheet 4 of 5) ..... 41

16 Detail H and Associated Views (Sheet 5 of 5) ..... 42

17 View I – Alternate Jacking Points (Sheet 1 of 2) ..... 42

17 View I – Alternate Jacking Points (Sheet 2 of 2) ..... 43

18 Forward Lower Panel Assembly Installed (Sheet 1 of 2) ..... 44

18 Forward Lower Panel Assembly Installed (Sheet 2 of 2) ..... 44

19 ADF Antenna Location (Sheet 1 of 2) ..... 45

19 ADF Antenna Location (Sheet 2 of 2) ..... 45

20 RT700 V/UHF Antenna Location (Sheet 1 of 2) ..... 46

20 RT700 V/UHF Antenna Location (Sheet 2 of 2) ..... 46

21 Bonding Layer P/N: 3P5340A45051 Installation (Sheet 1 of 9) ..... 47

21 Bonding Layer P/N: 3P5340A45051 Installation (Sheet 2 of 9) ..... 48

21 Bonding Layer P/N: 3P5340A45051 Installation (Sheet 3 of 9) ..... 49

21 Bonding Layer P/N: 3P5340A45051 Installation (Sheet 4 of 9) ..... 50

21 Bonding Layer P/N: 3P5340A45051 Installation (Sheet 5 of 9) ..... 51

21 Bonding Layer P/N: 3P5340A45051 Installation (Sheet 6 of 9) ..... 52

21 Bonding Layer P/N: 3P5340A45051 Installation (Sheet 7 of 9) ..... 53

21 Bonding Layer P/N: 3P5340A45051 Installation (Sheet 8 of 9) ..... 54

21 Bonding Layer P/N: 3P5340A45051 Installation (Sheet 9 of 9) ..... 54

**References**

**Table 1 References**

Data Module	Title
39-A-00-20-00-00A-120A-A	Helicopter safety - Pre-operation (make helicopter safe for maintenance)
39-A-53-40-00-00A-520A-A	Tail section (structure) - Remove procedure
39-A-53-50-00-00A-028A-K	Baggage compartments - General
39-A-52-44-02-00A-520A-A	Baggage compartment access panels - Remove procedure
39-A-28-11-01-00C-520A-K	Number 1 tank - Remove procedure
39-A-28-11-02-00B-520A-K	Number 2 tank - Remove procedure
39-A-21-32-00-00A-034A-K	Rear avionic bay ventilation system - Technical data (physical breakdown)
39-A-21-32-01-00A-520A-K	Left ventilation fan - Remove procedure
39-A-21-32-02-00A-520A-K	Right ventilation fan - Remove procedure
39-A-95-61-03-00A-520A-K	Aft left float assembly - Remove procedure
39-A-95-61-05-00A-520A-K	Aft right float assembly - Remove procedure
39-A-52-44-01-00A-520A-A	Access panels - Remove procedure
39-B-33-47-01-00A-520A-K	Bottom strobe light - Remove procedure
39-B-33-49-03-00A-520A-K	Search light mount - Remove procedure

**Table 2 Access Point**

Access Panel / Door Id	Data Module
No Access Point	

**Table 3 Zones**

Zone ID	Data Module
No Zones	

## *Preliminary requirements*

### Required conditions

Condition	Data Module/Technical Publication
Helicopter safety - Pre-operation (make helicopter safe for maintenance)	39-A-00-20-00-00A-120A-A
Tail section (structure) - Remove procedure	39-A-53-40-00-00A-520A-A
Baggage compartments - General	39-A-53-50-00-00A-028A-K
Baggage compartment access panels - Remove procedure	39-A-52-44-02-00A-520A-A
Number 1 tank - Remove procedure	39-A-28-11-01-00C-520A-K
Number 2 tank - Remove procedure	39-A-28-11-02-00B-520A-K
Rear avionics bay ventilation system - Technical data (physical breakdown)	39-A-21-32-00-00A-034A-K
Left ventilation fan - Remove procedure	39-A-21-32-01-00A-520A-K
Right ventilation fan - Remove procedure	39-A-21-32-02-00A-520A-K
Aft left float assembly - Remove procedure	39-A-95-61-03-00A-520A-K
Aft right float assembly - Remove procedure	39-A-95-61-05-00A-520A-K
Access panels - Remove procedure	39-A-52-44-01-00A-520A-A
Bottom strobe light - Remove procedure	39-B-33-47-01-00A-520A-K
Search light mount - Remove procedure	39-B-33-49-03-00A-520A-K

### Support equipment

**Table 5 Support Equipment**

Nomenclature	Identification No.	Qty.
1. Grip Gauge	Local Supply	1
2. Plastic Scraper	Local Supply	1
3. Cleaning Cloth	Local Supply	A.R.
4. Bond Tester	DUCTER Type D201 (or equivalent)	1
5. Temporary Fasteners	Cleco – Local Supply	A.R.
6. Heat Gun	Local Supply	1
7. Putty Knife	Local Supply	1

## Supplies

**Table 6 Supplies**

Nomenclature	Identification No.	Qty.
1. Non-metallic Channel	A236A01AB	1
2. Receptacle	A605A01	1
3. Support, Nylon	A630A31	1
4. Stud, ADH Bonded	A366A3E08C	A.R.
5. Stud, ADH Bonded	A366A3E16C	A.R.
6. Stud, ADH Bonded	A366A3E18C	A.R.
7. Stud, ADH Bonded	A366A3E22C	A.R.
8. Stud, ADH Bonded	A366A3E24C	A.R.
9. Stud, ADH Bonded	A366A3E32C75	A.R.
10. Stud, ADH Bonded	A388A3E06C	A.R.
11. Stud, ADH Bonded	A388A3E08C	A.R.
12. Stud, ADH Bonded	A388A3E08C75	A.R.
13. Nutplate	A900A3C2-01	A.R.
14. Screw	AN525-832R7	A.R.
15. Screw	AN525-10R8	28
16. Screw	AN525-10R9	20
17. Screw	AN525-10R10	12
18. Decal	ED300J202	1
19. Decal	ED300J204	1
20. Decal	ED300J206	1
21. Decal	ED300J208	1
22. Decal	ED300J209	1
23. Decal	ED300J211	1
24. Decal	ED300J253	1
25. Decal	ED300J301	1
26. Decal	ED300J303	1
27. Decal	ED300J360	1
28. Pin	HL19PB-5-11	1
29. Pin	HL20PB5-8	2
30. Pin	HL20PB-5-9	6
31. Pin	HL20PB-5-10	5
32. Pin	HL20PB-5-11	3
33. Collar	HL86PB-5	17
34. Nut	MS17825-4	12
35. Nut	MS17825-6	8
36. Rivet, Solid	MS40426AD3	A.R.
37. Rivet, Solid	MS40426AD4	A.R.

38. Rivet, Solid	MS20470AD4	A.R.
39. Rivet, Solid	MS20470AD5	A.R.
40. Nut	MS21042L08	2
41. Nutplate	MS21069L3	20
42. Cotter Pin	MS24665-134	12
43. Cotter Pin	MS24665-285	8
44. Screw	MS24694-S52	16
45. Mounting Base, Tie-down	MS3341-1-9	A.R.
46. Screw	MS35206-246	2
47. Washer	NAS1149F0432P	12
48. Washer	NAS1149F0632P	8
49. Washer	NAS1149DN832H	8
50. Nutplate	NAS1474A08	A.R.
51. Nutplate	NAS1474A3	16
52. Insert	NAS1832C3-3M	A.R.
53. Insert	NAS1832-08-4	14
54. Bolt	NAS6604D7	8
55. Bolt	NAS6604D12	8
56. Bolt	NAS6606D7	8
57. Sealing Compound (*)	ProSeal 890 B2	A.R.
58. Surface Treatment (*)	Alodine 1200	A.R.
59. Cleaning Solvent (*)	MEK	A.R.

## Spares

**Table 7 Support Equipment**

Nomenclature	Identification No.	Qty
1. Lower Panel Assy	3P5340A01431 (3P5340A01431M01 alternate)	1
1. Lower Panel Assy	3P5340A43631 (3P5340A43631M01 alternate)	1
2. Bonding Layer	3P5340A45051	2



## Safety conditions

### **WARNING**

The materials that follow are dangerous. Before you do this procedure, make sure that you know all the safety precautions and first aid instructions for these materials:

- **Sealing compound** (Supply Ref. 57)
- **Surface Treatment** (Supply Ref. 58)
- **Cleaning Solvent** (Supply Ref. 59)

### **CAUTION**

The following procedures have to be carried out by a maintenance organization approved for major repair.

## ***Procedure***

### **NOTES:**

1. Place an identification tag on all components that are re-usable, including the attaching hardware that has been removed to gain access to the medication area and adequately protect them until their later re-use.
2. Exercise extreme care during drilling operations to prevent instruments, components, cables and hose damage.
3. After drilling, remove all swarf and sharp edges. Apply on bare metal a light film of primer unless the hole is used for grounding connections.
4. During rivet drill out and removal operations, to prevent and eliminate the presence Foreign Object Debris (FOD), protect adequately the area around the work area and to prevent FOD infiltrating installed components and instruments.
5. Take detailed digital photographs of aircraft configuration prior to work being performed. This will aide in maintaining aircraft configuration during reassembly and reinstallation of components and systems.
6. Before installing new rivets check the holes condition; if the holes condition is not suitable it is necessary to use oversized rivets.
7. Perform an integrity check of all items removed. If deemed necessary, discard the item and replace with new item.
8. Use Cleaning Solvent (Supply Ref. 59) to clean surfaces. All cleaned surfaces must air dry for at least 30 minutes.
9. Let adhesives cure at room temperature for at least 24 hours unless otherwise specified.
10. All lengths and dimensions are in millimetres (mm).

11. For fuselages 41499 and prior, use Forward Lower Panel Assy P/N: 3P5340A01431 and for ones 41500 and after, use Forward Lower Panel Assy P/N: 3P5340A43631.
  12. If Forward Lower Panel Assy P/N: 3P5340A43631 is unavailable, you may use P/N: 3P5340A43631M01 or upgrade Forward Lower Panel Assy P/N: 3P5340A01431 (or P/N: 3P5340A01431M01) by adding Bonding Layer (Spares Equip. 2) by using Figure 21 as reference.
1. Aircraft must be made level per AMP 39-A-08-21-00-00A-000A-A except as follows:
    - 1.1. New left hand and right hand jacking points must be manufactured locally as shown in Figure 17 (Detail I).
    - 1.2. Install new left hand and right hand jacking points as shown in Figure 17 (Detail I) at STA 5700. If necessary, add shims to ensure proper fit.
    - 1.3. Proceed to level aircraft per AMP 39-A-08-21-00-00A-000A-A.
  2. Get access to the Work Area (Figure 1):
    - 2.1. Remove any optional or after-market equipment that is installed in the general work area which will be impacted by the removal of the existing lower panel assembly. To remove the ADF antenna, use Figure 19 as reference. To remove RT700 V/UHF antenna, use Figure 20 as reference.
    - 2.2. Carefully protect and reposition any wires or wire bundles that will be impacted by the removal of the existing left skin assembly.
  3. Remove Left Hand and Right Hand Lower Cabin Door Track per Figure 8 (Detail F) and retain for reinstallation.
  4. Remove 3P5340A01731 Lower Panel as follows:
    - 4.1. Per Figure 4 (Section B-B and View B2), remove rivets securing the 3P5340A01731 Lower Panel to frame at STA 7200; also remove MS21069L3 nutplates which secure the Lower Panel to the 3P5340A15951 channel.
    - 4.2. Per Figure 5 (Section C-C and View C3), remove rivets securing the 3P5340A01731 Lower Panel to frame at STA 8150; also remove MS21069L3 nutplates which secure the Lower Panel to the 3P5340A16051 channel.
    - 4.3. With all the fasteners removed, use a Heat Gun (Support Equip. 6) to soften the adhesive and carefully work a Putty Knife (Support Equip. 3) around the perimeter of the panel to break the seal between the panel and the fuselage.
    - 4.4. Remove 3P5340A01731 Lower Panel and retain for installation.
    - 4.5. Do not remove 3P5340A15951 left-hand channel or 3P5340A16051 right-hand channel.

5. Remove grounding point receptacle on right-hand side of existing lower panel assembly per Figure 4 (View B5) and retain for reinstallation.
6. Remove existing Lower Panel Assembly as follows:
  - 6.1. Expose and remove fasteners used to secure existing lower panel assembly to the fuselage per Figure 4 (Section B-B), Figure 6 (Detail D) and Figure 7 (Detail E)
  - 6.2. Remove necessary fasteners of overlapping skins to gain access to all the edges of lower panel assembly per Figure 4 (Section B-B), Figure 6 (Detail D) and Figure 7 (Detail E)
  - 6.3. Remove both left-hand and right-hand jack points per Figure 7 (View E2) (Detail E3) and (Section E4-E4) and retain for reinstallation.
  - 6.4. Remove both 3P5330A18352 Left Rear Cover and 3P5330A18452 Right Rear Cover per Figure 7 (Detail E3 and Detail E5) and retain for reinstallation.
  - 6.5. With all the fasteners removed, use a Heat Gun (Support Equip. 6) to soften the adhesive and carefully work a Putty Knife (Support Equip. 7) around the perimeter of the panel to break the seal between the panel and the fuselage.
  - 6.6. Once removed, retain old panel to serve as a template.
  - 6.7. Also retain any shims that were used for the old panel for reinstallation of the new Forward Lower Panel Assembly (Spares Equip. 1).
  - 6.8. Using Cleaning Solvent (Supplies Ref. 59), Plastic Scraper (Support Equip. 3) and lint – free Cleaning Cloth (Support Equip. 3), clean and prepare all surfaces for installation of new Forward Lower Panel Assembly (Spares Equip. 1).

### CAUTION

**The fabrication of a template of suitable material is absolutely necessary. Countermark holes onto template using the removed old lower panel assembly from Step 7.6.**

7. Install new Forward Lower Panel Assembly (Spares Equip. 1) as follows:
  - 7.1. Fit and position new panel.
  - 7.2. If installing the alternate panels P/N: 3P5340A01431M01 or 3P5340A43631M01, trim panels as required for proper fit.
  - 7.3. Transfer the holes from the template onto the new Forward Lower Panel Assembly (Spares Equip. 1).
  - 7.4. Reinstall both 183BL and 184BR Access Panels per AMP 39-A-52-44-01-00A-720A-A.
  - 7.5. With the new Forward Lower Panel Assembly (Spares Equip. 1) in place, counter drill fastener holes into existing fuselage while installing Temporary Fasteners (Support Equip. 5) as necessary.

- 7.6. Apply Surface Treatment (Supply Ref. 58) to all reworked and exposed surfaces.
  - 7.7. Reinstall new Forward Lower Panel Assembly (Spares Equip. 1) using Temporary Fasteners (Support Equip. 5) and countersink required holes.
  - 7.8. Remove new Forward Lower Panel Assembly (Spares Equip. 1), deburr and remove sharp edges.
  - 7.9. Reinstall both 183BL and 184BR Access Panels per AMP 39-A-52-44-01-00A-720A-A.
  - 7.10. All blind rivets are to be installed "wet".
  - 7.11. Install all fasteners using a Grip Gage (Support Equip. 1) to check length of blind fasteners.
  - 7.12. Apply Sealing Compound (Supply Ref. 57) to mating surfaces and install new Forward Lower Panel Assembly (Spares Equip. 1) per Figure 4 (Section B-B), Figure 6 (Detail D) and Figure 7 (Detail E).
  - 7.13. Apply Surface Treatment (Supply Ref. 58) to all reworked and exposed surfaces with the exception of the Bonding Layer (Spares Equip. 2), if installed.
8. Reinstall both 3P5330A18352 Left Rear Cover and 3P5330A18452 Right Rear Cover per Figure 7 (Detail E3 and Detail E5).
  9. Remove both left-hand and right-hand jack points per Figure 7 (View E2) (Detail E3) and (Section E4-E4).
  10. Install Clipping Supports (Fig. 13) as follows:
    - 10.1. Install Clipping Supports per Figure 11 (View G1).
    - 10.2. Install Clipping Supports per Figure 12 (View G2).
    - 10.3. Install Clipping Supports and decals per Figure 13 (View G3).
    - 10.4. Install Clipping Supports and decals per Figure 14 (View G4).
  11. Prepare surface of new Forward Lower Panel Assembly (Spares Equip. 1) and install inserts for component grounding and installation per Figure 15 (Detail G5).
  12. Reinstall 3P5340A01731 Lower Panel as follows:
    - 12.1. Using Cleaning Solvent (Supplies Ref. 59), Plastic Scrapper (Support Equip. 2) and lint – free Cleaning Cloth (Support Equip. 3), clean and prepare all surfaces for reinstallation of 3P5340A01731 Lower Panel.
    - 12.2. All blind rivets are to be installed "wet".
    - 12.3. Install all fasteners using a Grip Gage (Support Equip. 1) to check length of blind fasteners.
    - 12.4. Apply Sealing Compound (Supply Ref. 57) to mating surfaces and reinstall 3P5340A01731 Lower Panel per Figure 4 (Section B-B) and Figure 5 (Section C-C).
    - 12.5. Apply Surface Treatment (Supply Ref. 58) to all reworked and exposed surfaces.
  13. Reinstall nutplates for 3P5340A01931 Lower Cover (Access Panel 180AL) as follows:

- 13.1. Install nutplates onto new Forward Lower Panel Assembly (Spares Equip. 1) per Figure 3 (Detail A).
14. Install provisions for 3G5315A13611 Strobe Light Support as follows:
  - 14.1. Install strobe light support provisions into new Forward Lower Panel Assembly (Spares Equip. 1) per Figure 16 (View H) (Detail H1) (Section H1-H1) and (Section H4-H4).
  - 14.2. Install inserts per Figure 16 (Section H2-H2) and (Section H3-H3).
15. Reinstall Left Hand and Right Hand Lower Sliding Cabin Door Track per Figure 8 (Detail F).
16. Reinstall grounding point receptacle on RH side of new Forward Lower Panel Assembly (Spares Equip. 1) per Figure 4 (View B5) (Section B9-B9) and (Section B10-B10).
17. If applicable, reinstall ADF antenna using Figure 19 as reference.
18. If applicable, reinstall RT7000 V/UHF antenna using Figure 21 as reference.
19. If applicable, reinstall any optional or after-market equipment that was removed.
20. Remove from old panel the aircraft identification plate and reinstall onto new Forward Lower Panel Assembly (Spares Equip. 1).
21. If installed, reinstall engine wash module onto new Forward Lower Panel Assembly (Spares Equip. 1) per vendor STC instructions; see Figure 4 for reference.
22. In accordance with Annex A, perform an electrical bonding check between the Forward Lower Panel Assembly (Spares Equip. 1) and the main fuselage structure and electrical generator grounds.

### ***Requirements after job completion***

1. Remove all the tools and the other items from the work area.
2. Make sure that the work area is clean and free of foreign object debris.
3. Return aircraft to flight configuration.

FIGURES

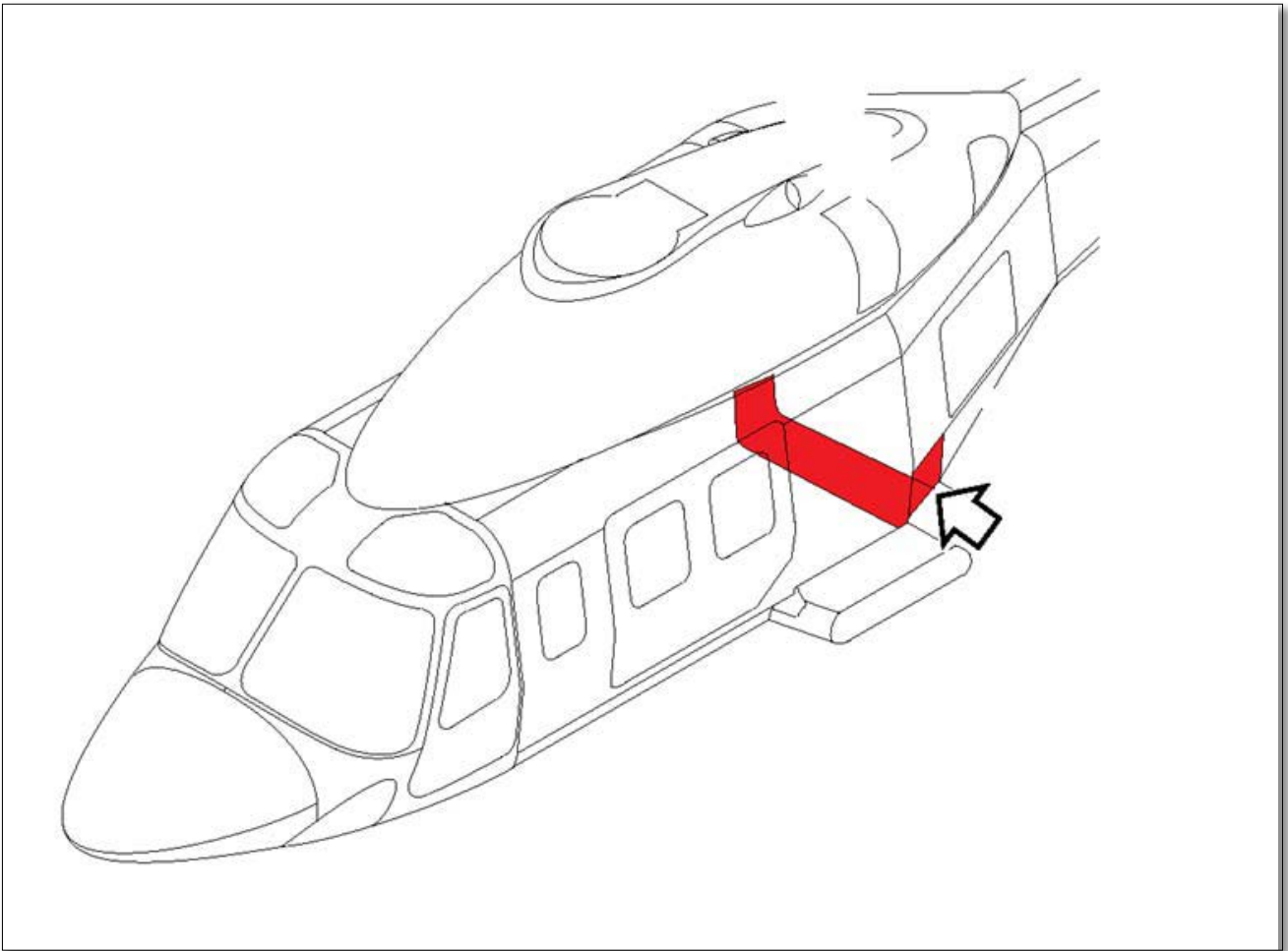

Figure 1 – Work Area – Forward Lower Panel Assy

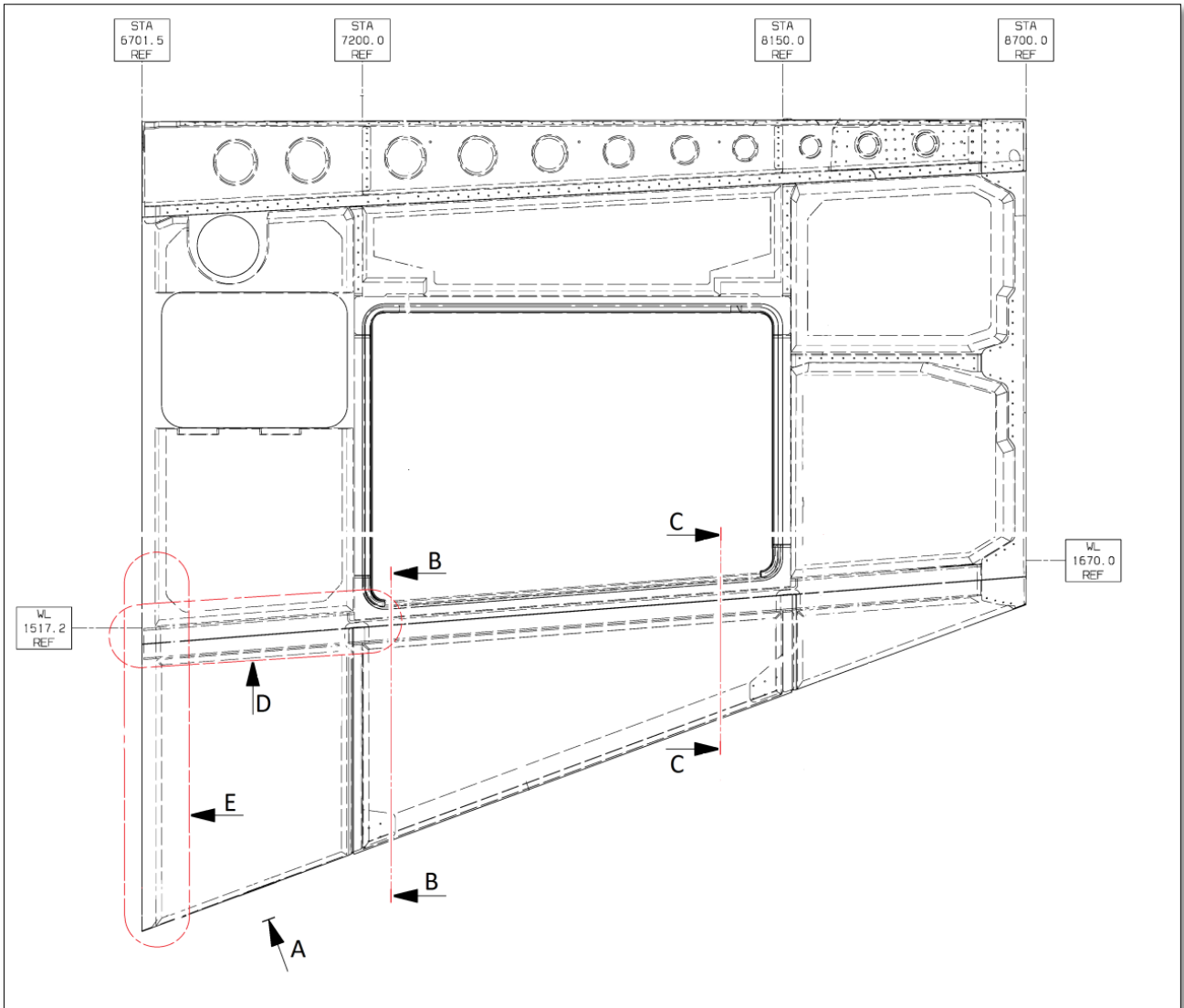

Figure 2 – Main View – Looking Inboard (Sheet 1 of 2)





**Figure 2 – Main View – Looking Inboard (Sheet 2 of 2)**



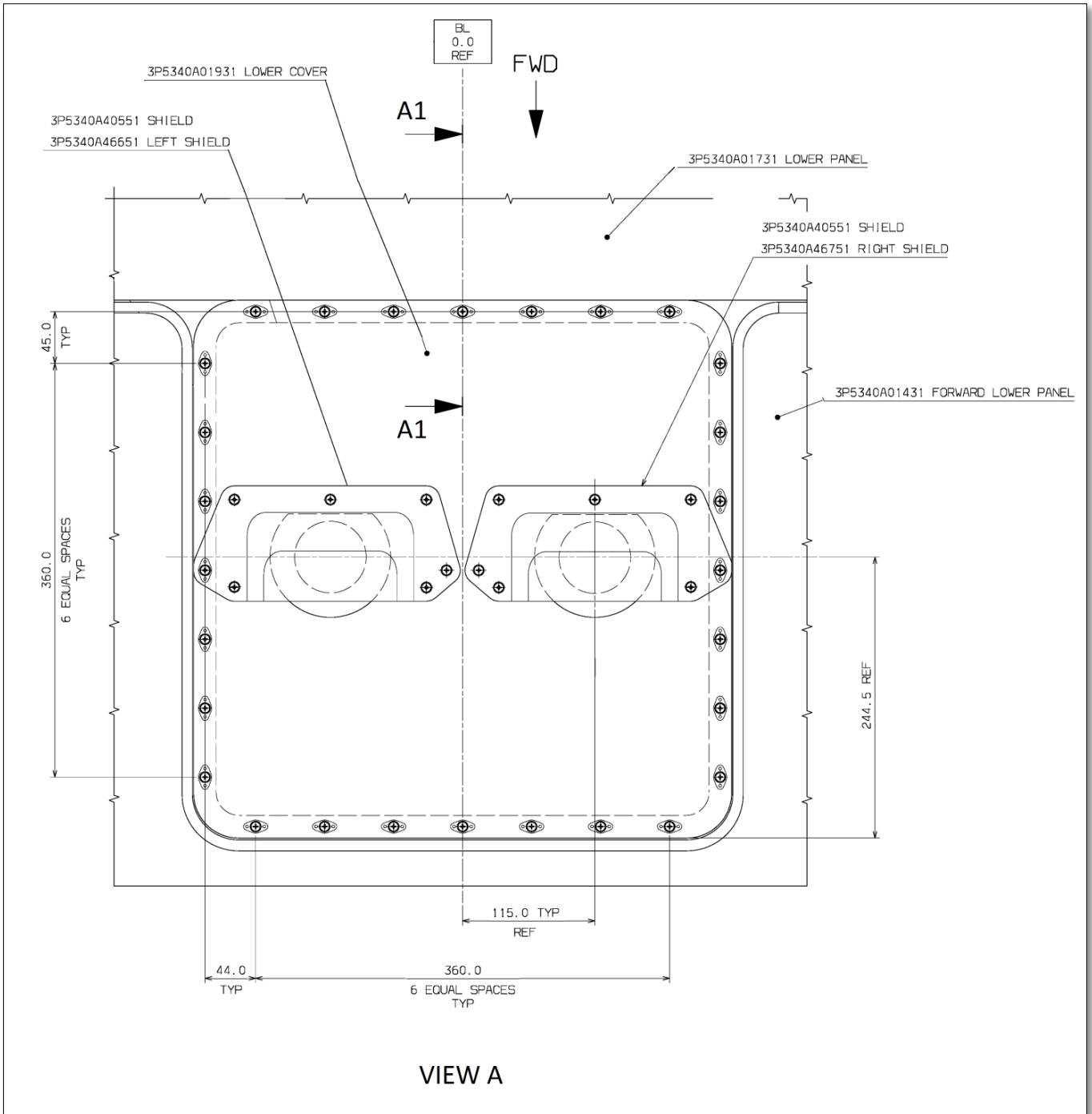

Figure 3 – View A and Associated Views (Sheet 1 of 3)

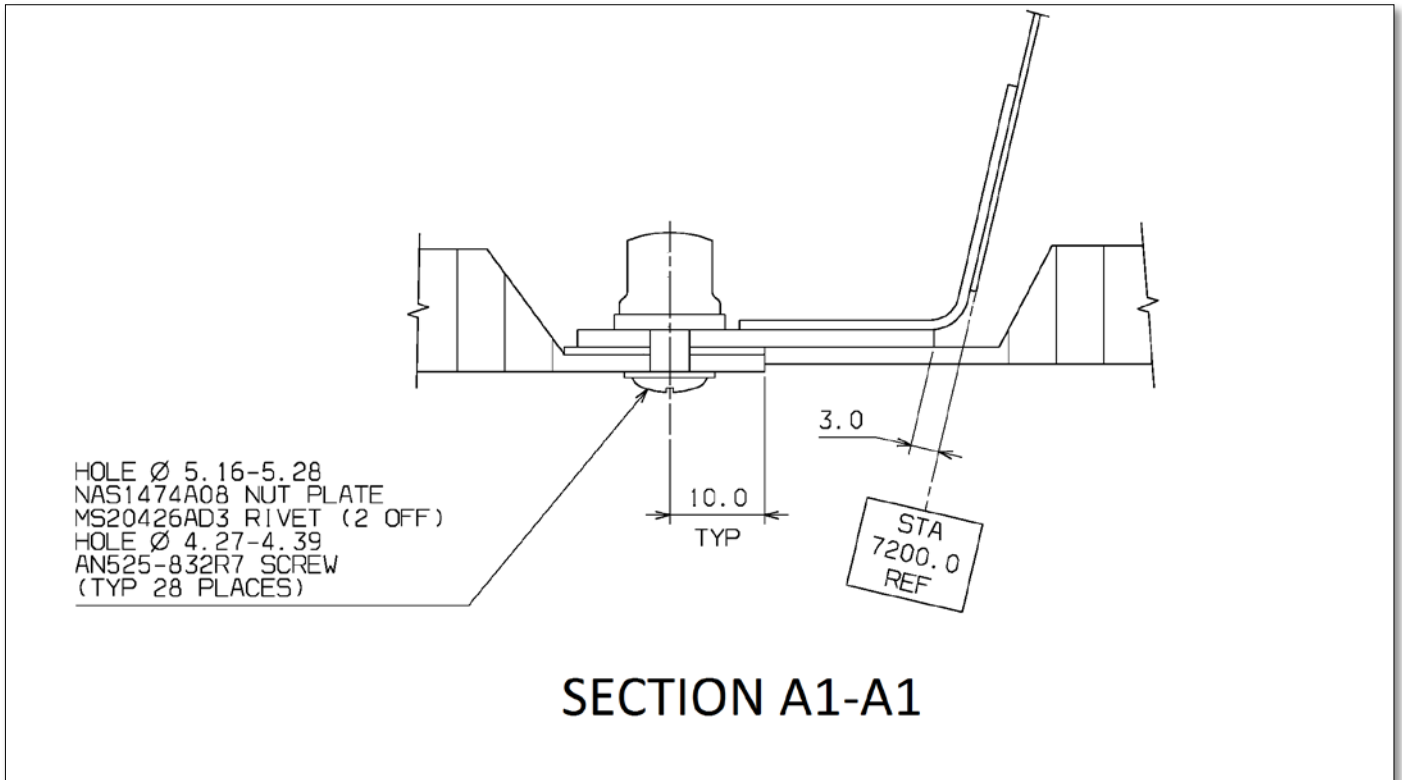

Figure 3 – View A and Associated Views (Sheet 2 of 3)



Figure 3 – View A and Associated Views (Sheet 3 of 3)

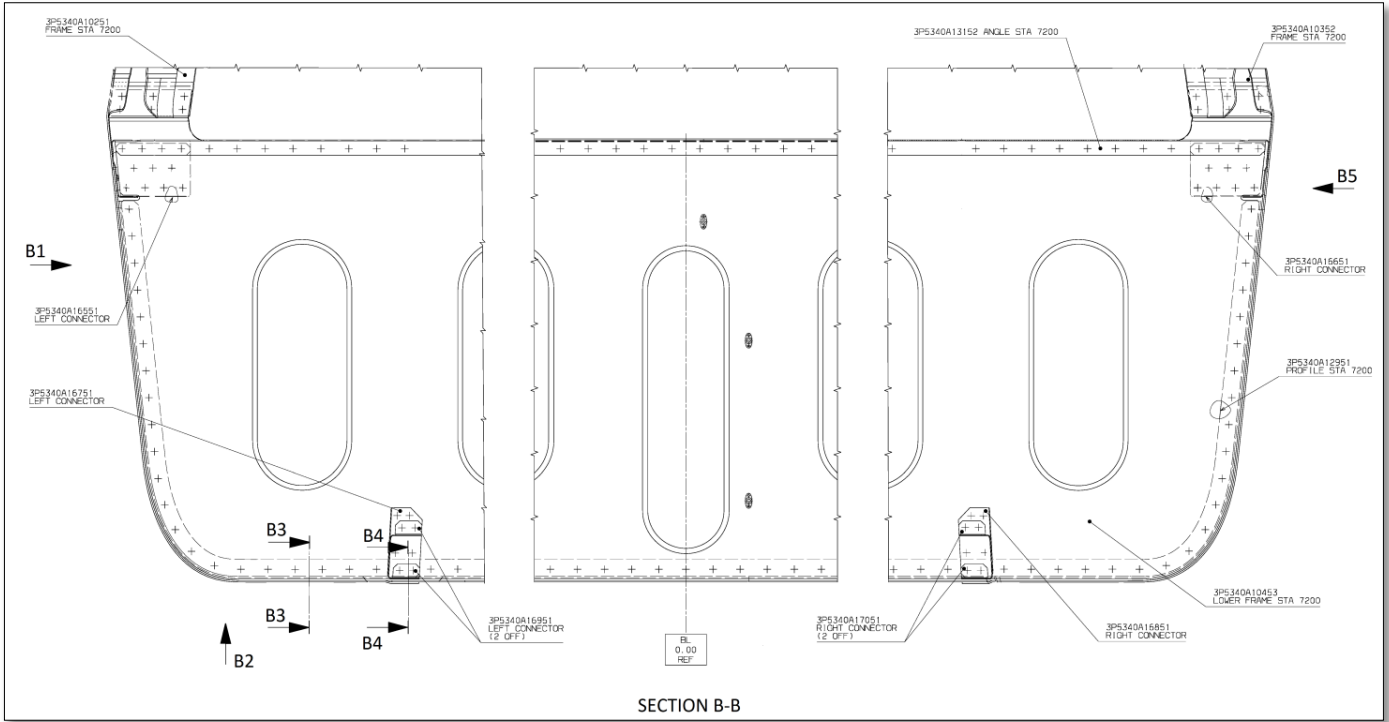

Figure 4 – Section B-B and Associated Views (Sheet 1 of 6)

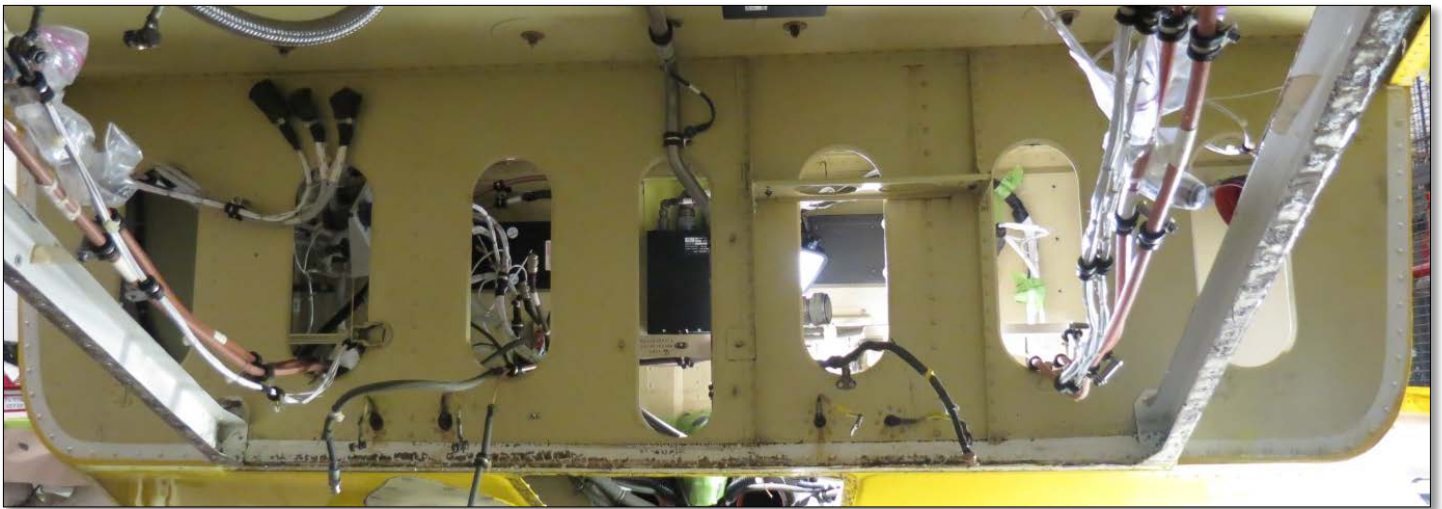

Figure 4 – Section B-B and Associated Views (Sheet 2 of 6)

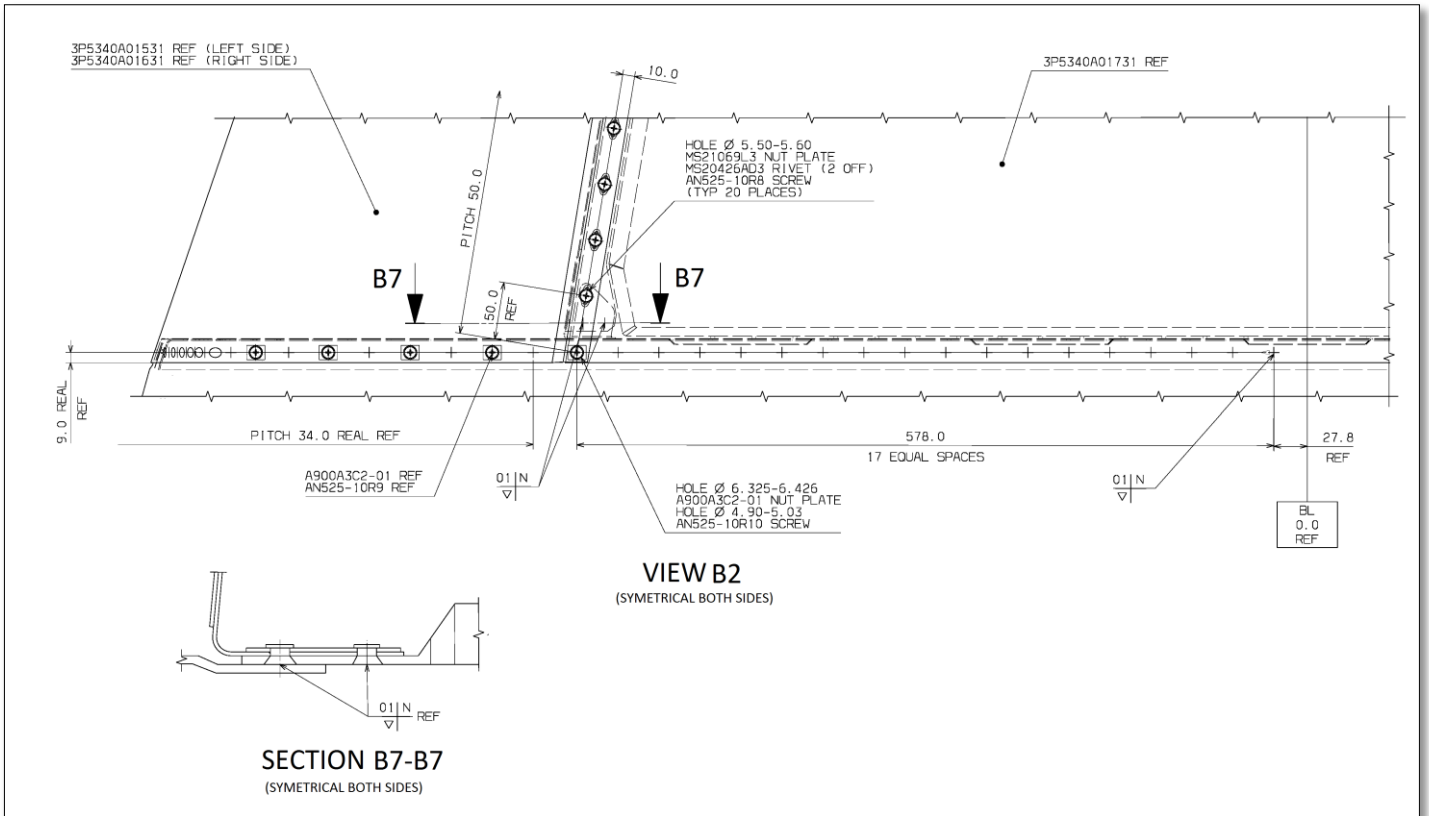

Figure 4 – Section B-B and Associated Views (Sheet 3 of 6)

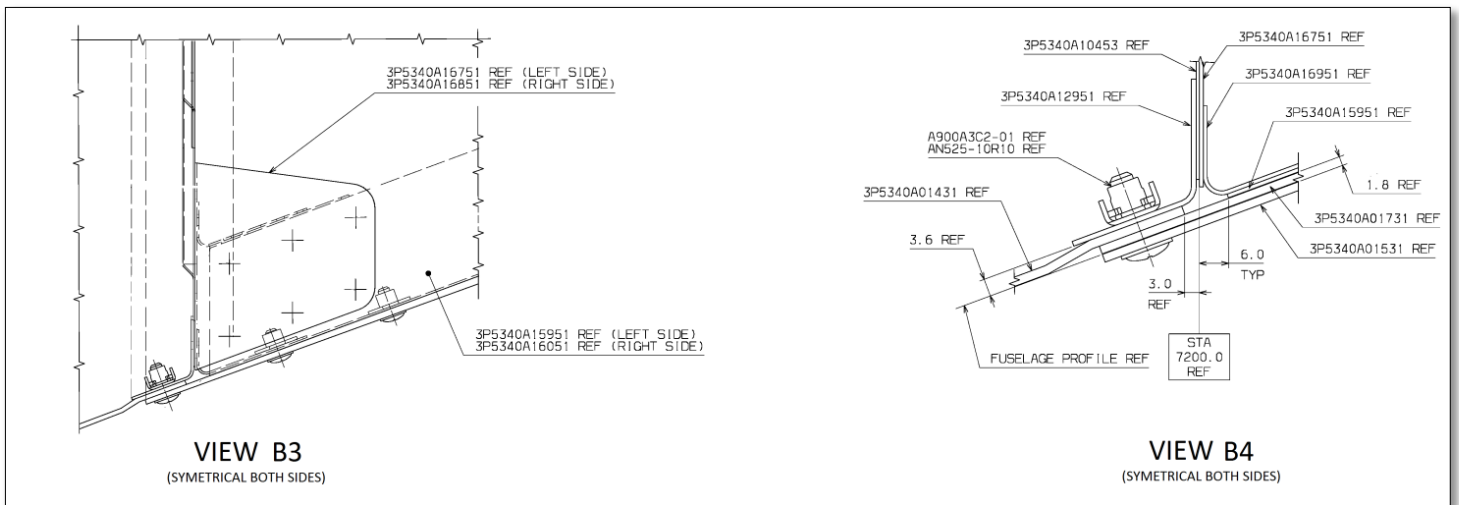

Figure 4 – Section B-B and Associated Views (Sheet 4 of 6)

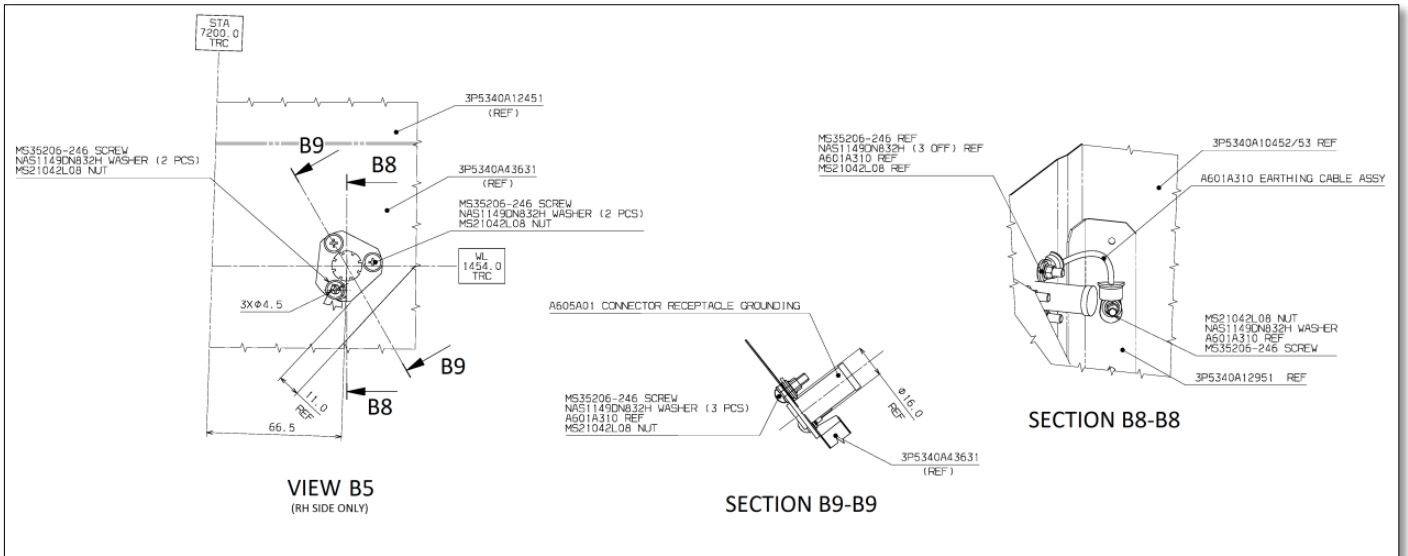

Figure 4 – Section B-B and Associated Views (Sheet 5 of 6)

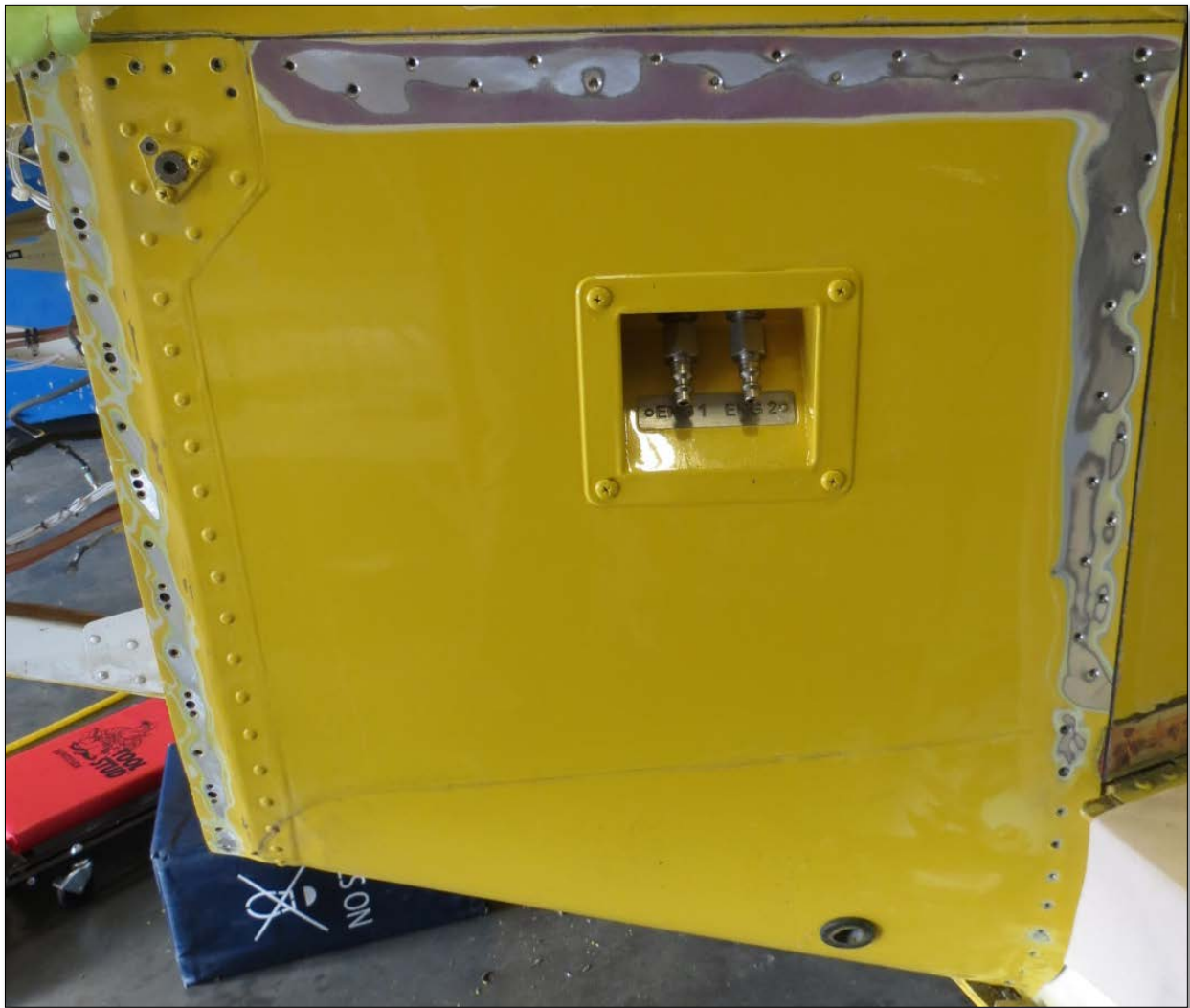

Figure 4 – Section B-B and Associated Views (Sheet 6 of 6)



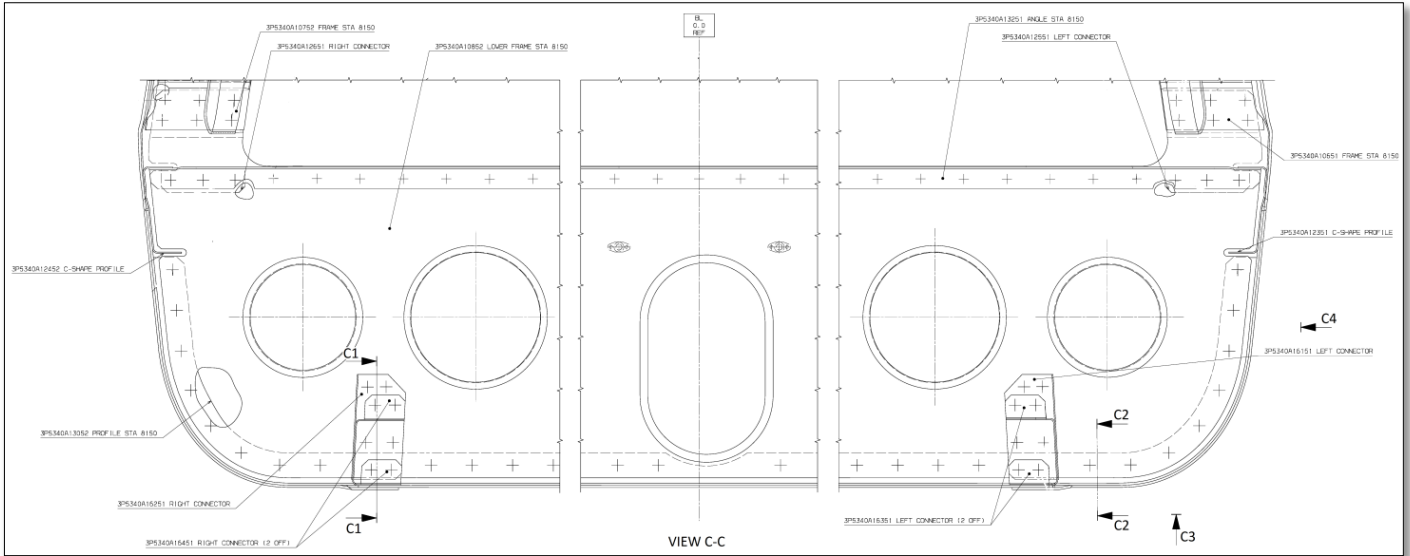

Figure 5 – Section C-C and Associated Views (Sheet 1 of 4)

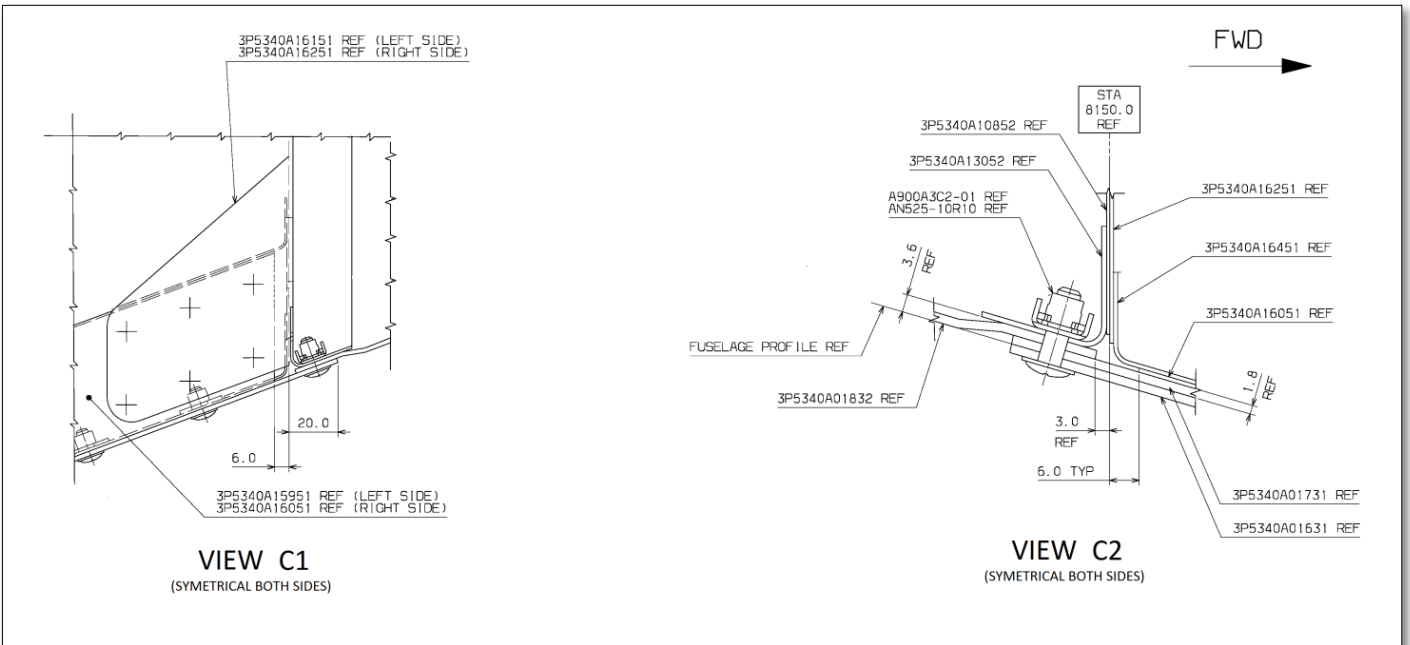

Figure 5 – Section C-C and Associated Views (Sheet 2 of 4)

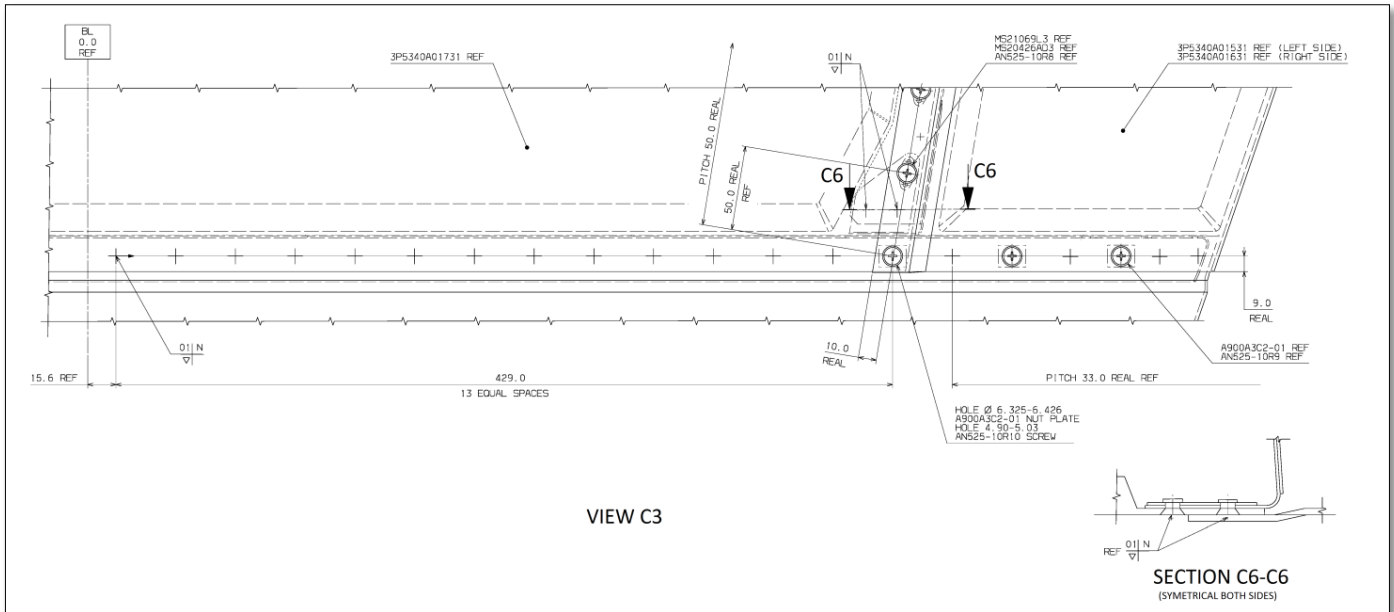

Figure 5 – Section C-C and Associated Views (Sheet 3 of 4)

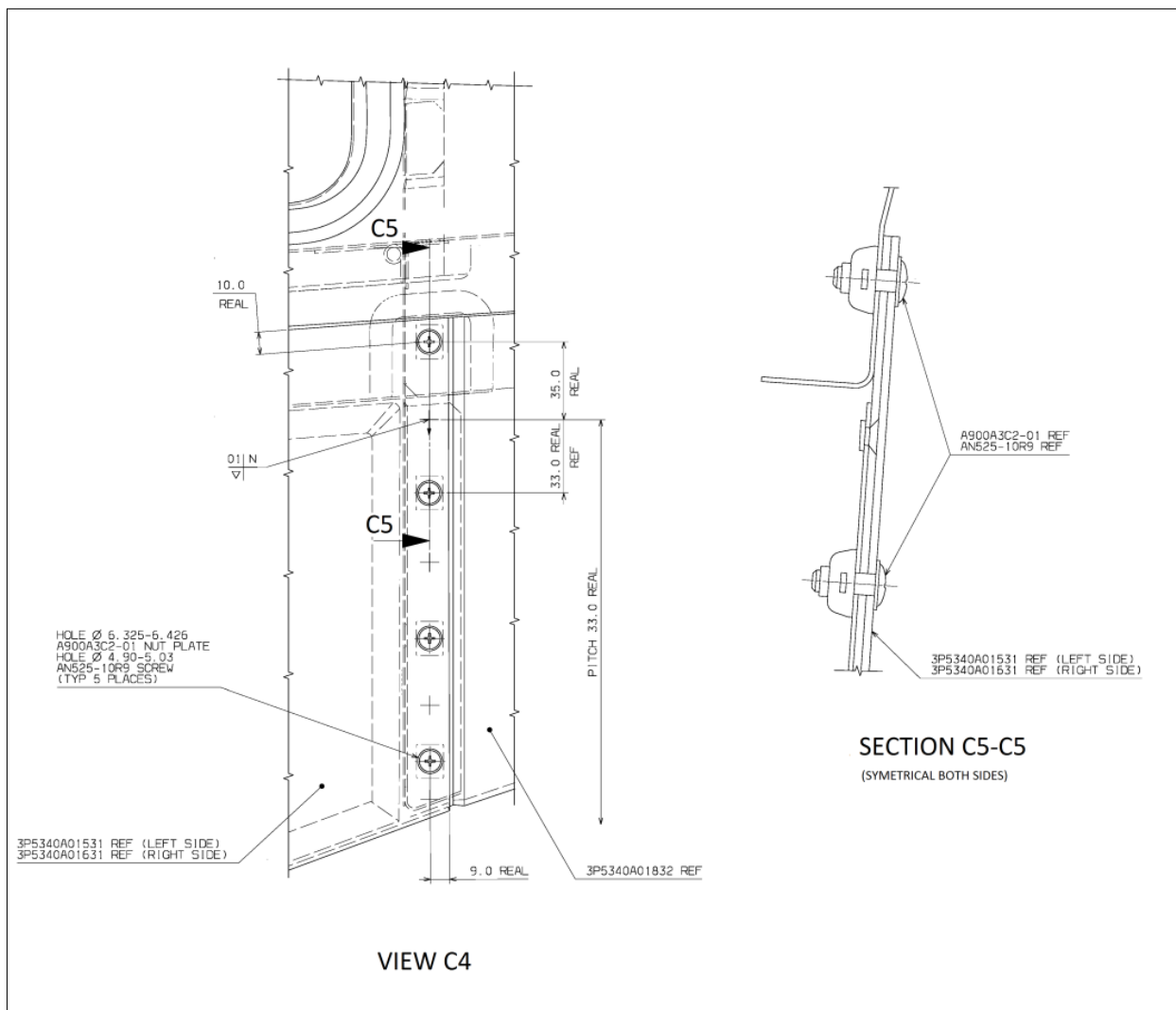

Figure 5 – Section C-C and Associated Views (Sheet 4 of 4)

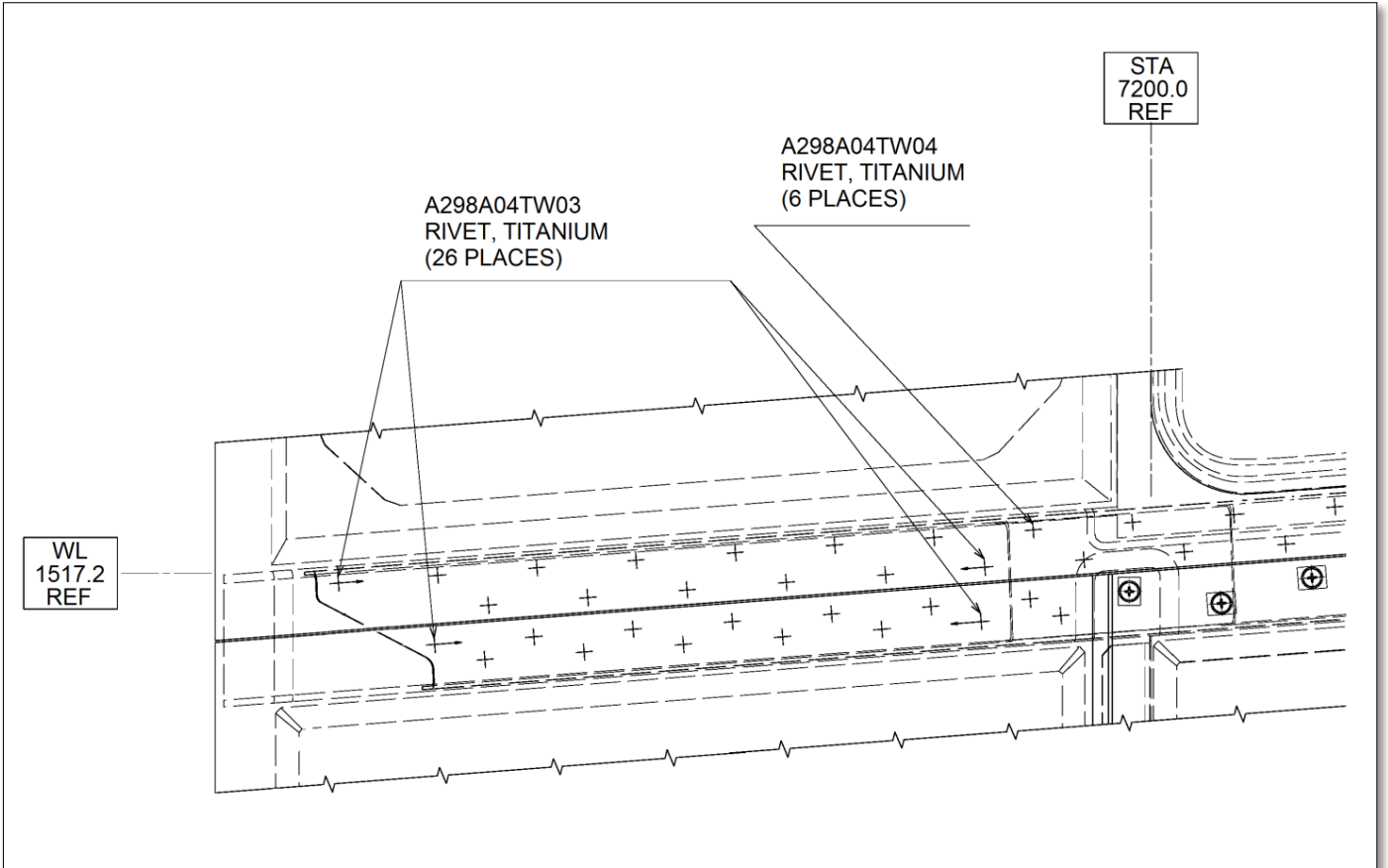

Figure 6 – Detail D and Associated Views (Sheet 1 of 2)



Figure 6 – Detail D and Associated Views (Sheet 2 of 2)



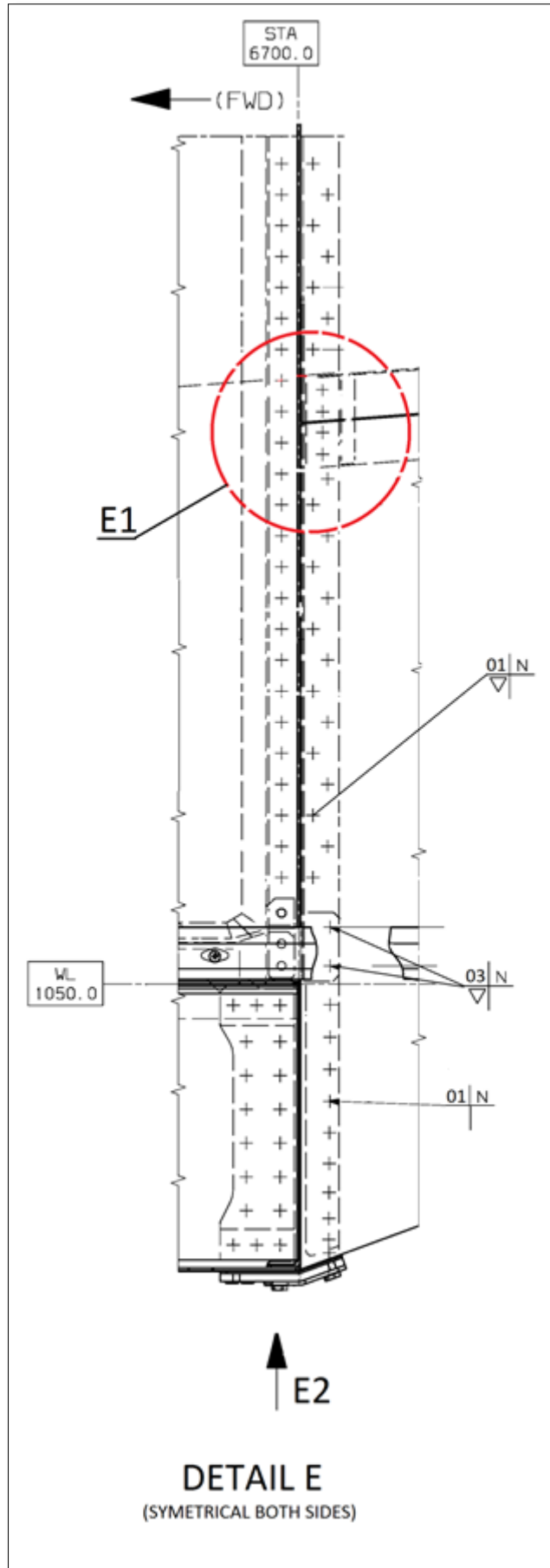

Figure 7 – Detail E and Associated Views (Sheet 1 of 6)



Figure 7 – Detail E and Associated Views (Sheet 2 of 6)

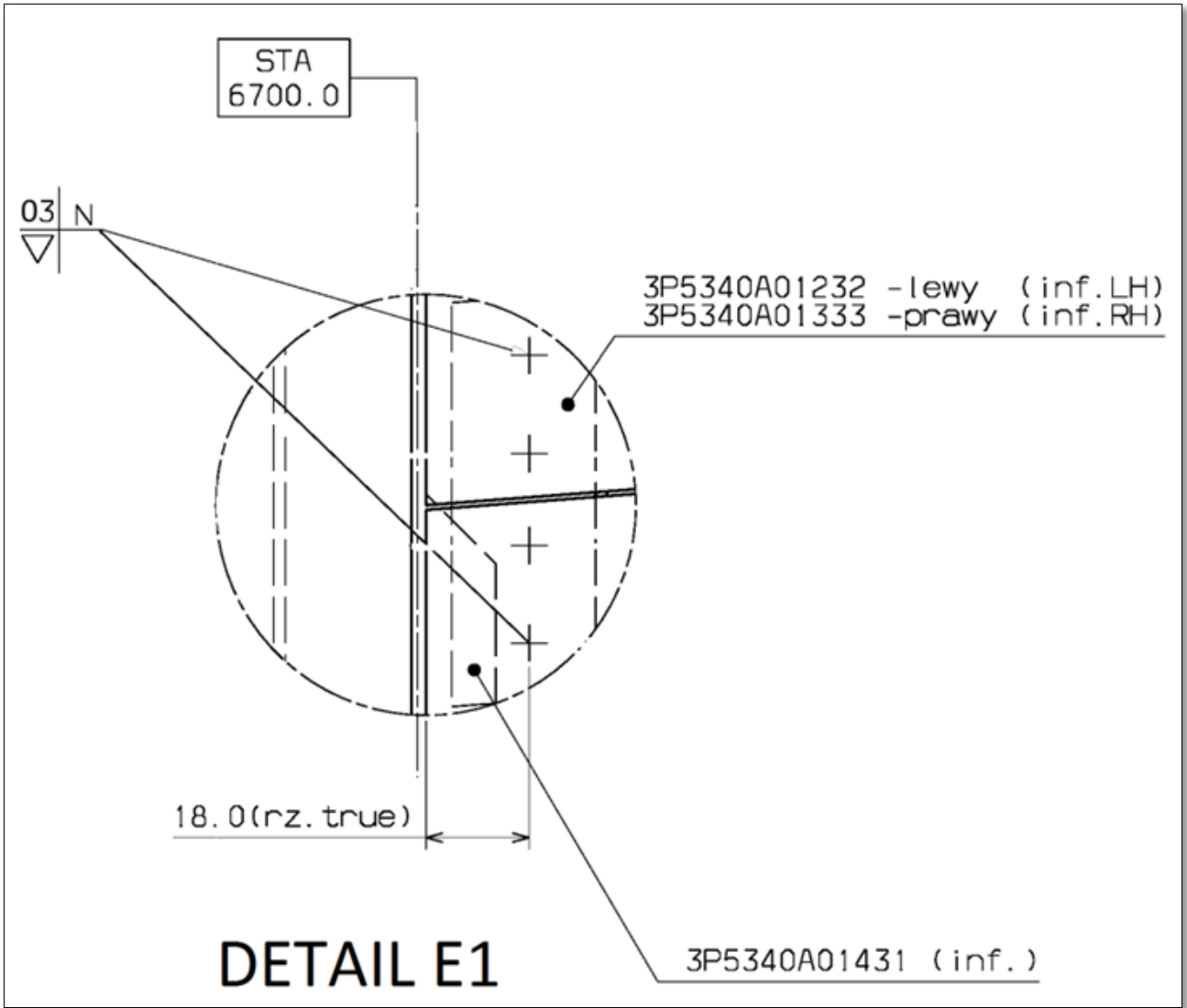

Figure 7 – Detail E and Associated Views (Sheet 3 of 6)

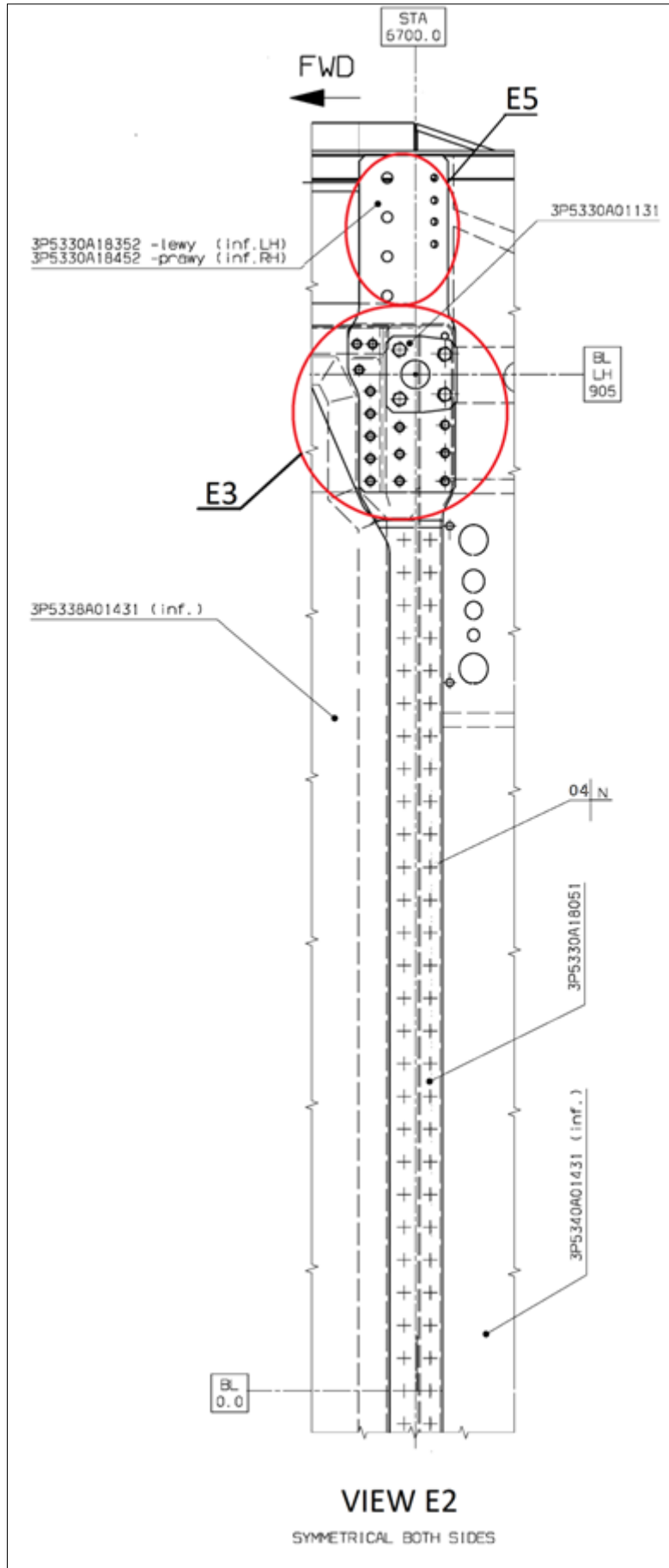

Figure 7 – Detail E and Associated Views (Sheet 4 of 6)

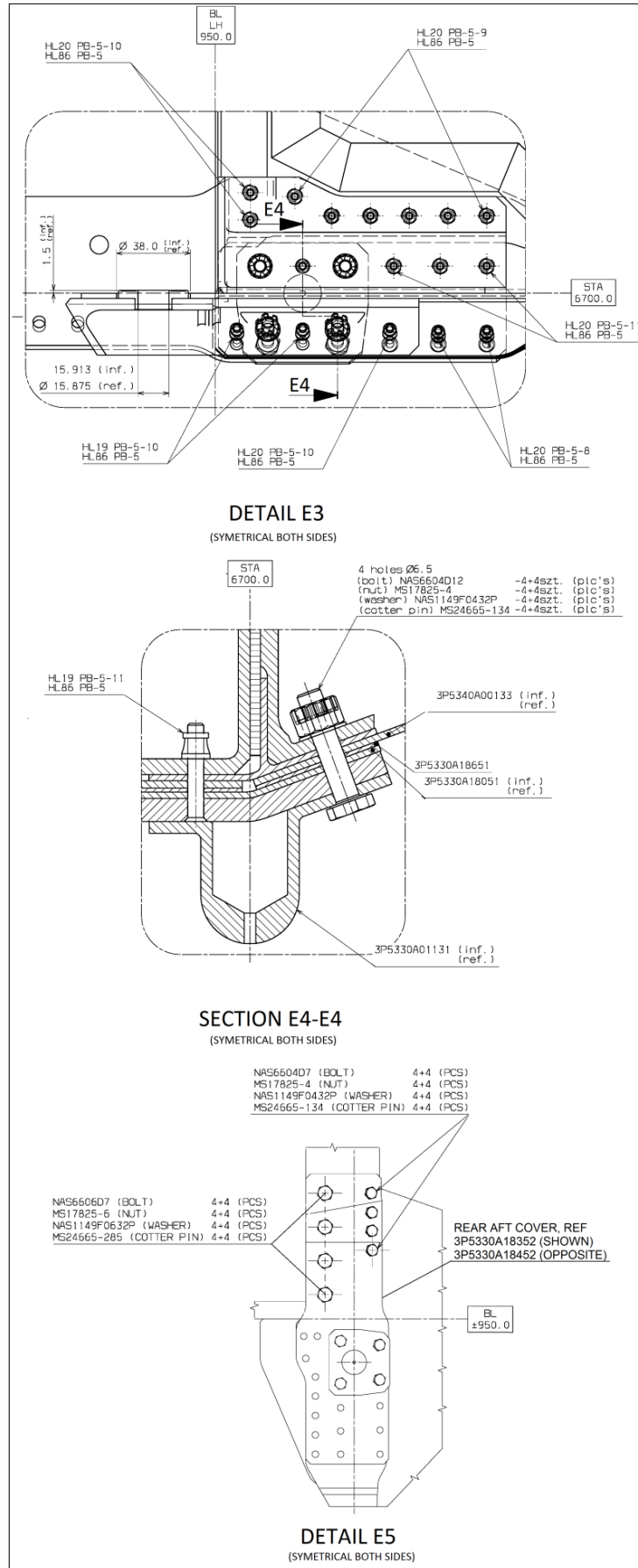

Figure 7 – Detail E and Associated Views (Sheet 5 of 6)



Figure 7 – Detail E and Associated Views (Sheet 6 of 6)

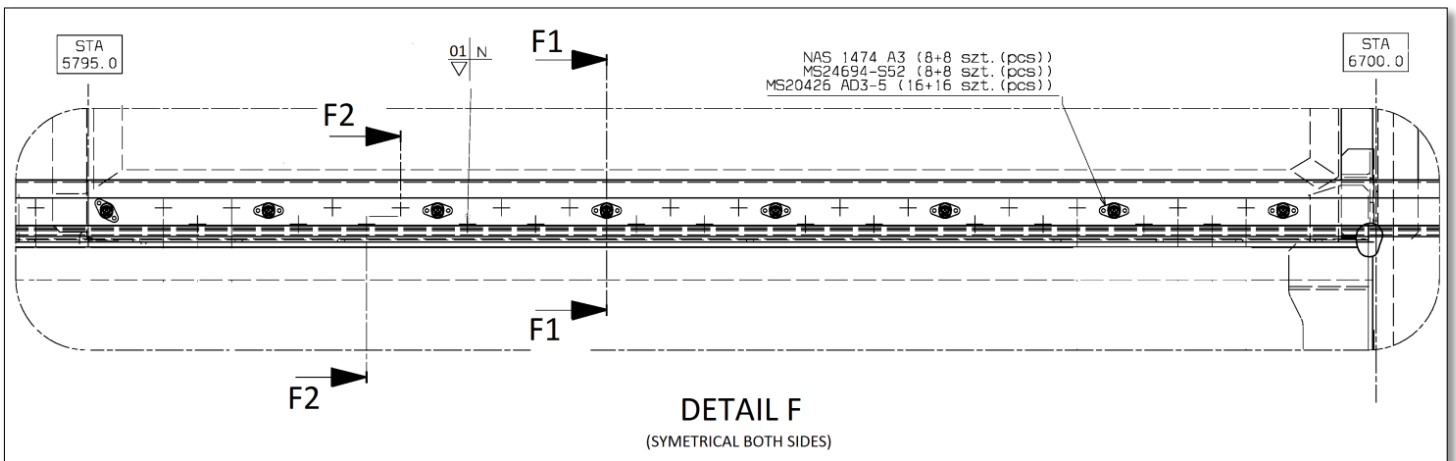

Figure 8 – Detail F and Associated Views (Sheet 1 of 3)

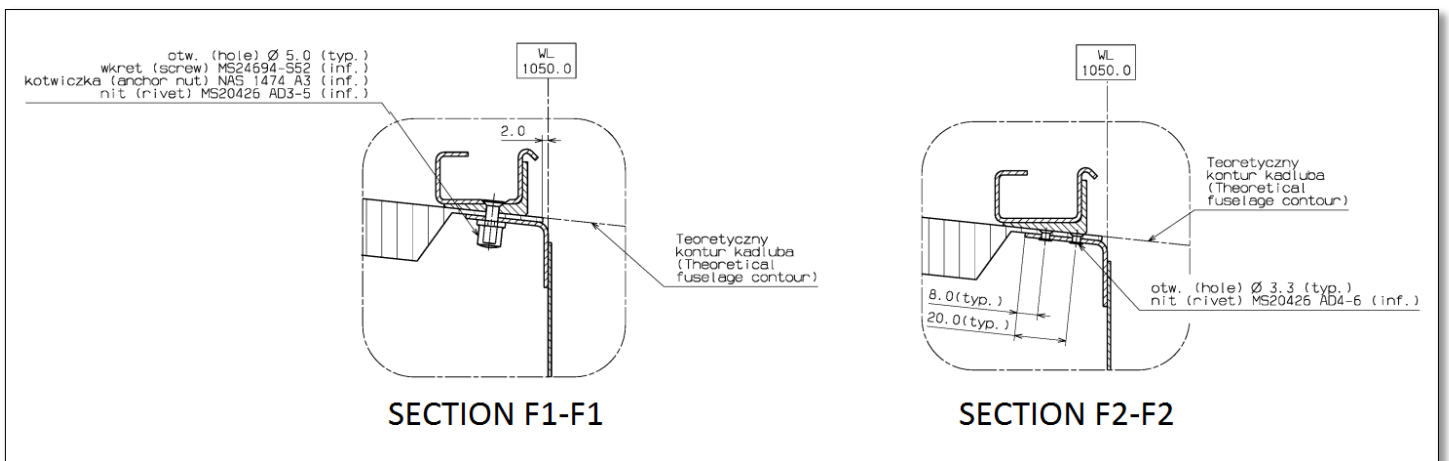

Figure 8 – Detail F and Associated Views (Sheet 2 of 3)



Figure 8 – Detail F and Associated Views (Sheet 3 of 3)

RIVET CODE IN ACCORDANCE WITH NTA018R CODICE RIVETTO SECONDO NTA018R			
REF. NUMBER/ NUMERO DI RIFERIMENTO		ORIENTATION/ ORIENTAMENTO	
COUNTERSINK/ TIPO DI SVASATURA		BLANK/ LASCIARE LIBERO	
<b>NOTE:</b> EDGE DISTANCE FROM CENTRELIN E EXCEPT WHERE INDICATED OTHERWISE		<b>NOTA:</b> DISTANZA DEL BORDO DALL'ASSE ECCETTO COME INDICATO	
<b>NON-COMPOSITE</b> UNIVERSAL HEAD 2 TIMES SHANK DIA. COUNTERSINK HEAD 2.5 TIMES SHANK DIA.		<b>NON-COMPOSITO</b> TESTA UNIVERSALE 2 VOLTE IL DIAMETRO DEL GAMBO. TESTA SVASATA 2.5 VOLTE IL DIAMETRO DEL GAMBO.	
<b>COMPOSITE</b> UNIVERSAL HEAD 2.5 TIMES SHANK DIA. COUNTERSINK HEAD 3 TIMES SHANK DIA.		<b>COMPOSITO</b> TESTA UNIVERSALE 2.5 VOLTE IL DIAMETRO DEL GAMBO. TESTA SVASATA 3 VOLTE IL DIAMETRO DEL GAMBO.	
REF No/ No RIF	RIVET PART NUMBER/ NUMERO PEZZO RIVETTO	REF No/ No RIF	RIVET PART NUMBER/ NUMERO PEZZO RIVETTO
01	MS20426AD4	10	
02	MS20470AD4	11	
03	MS20426AD5	12	
04	MS20470AD5	13	
05		14	
06		15	
07		16	
08		17	
09		18	

Figure 9 – Rivet Codes

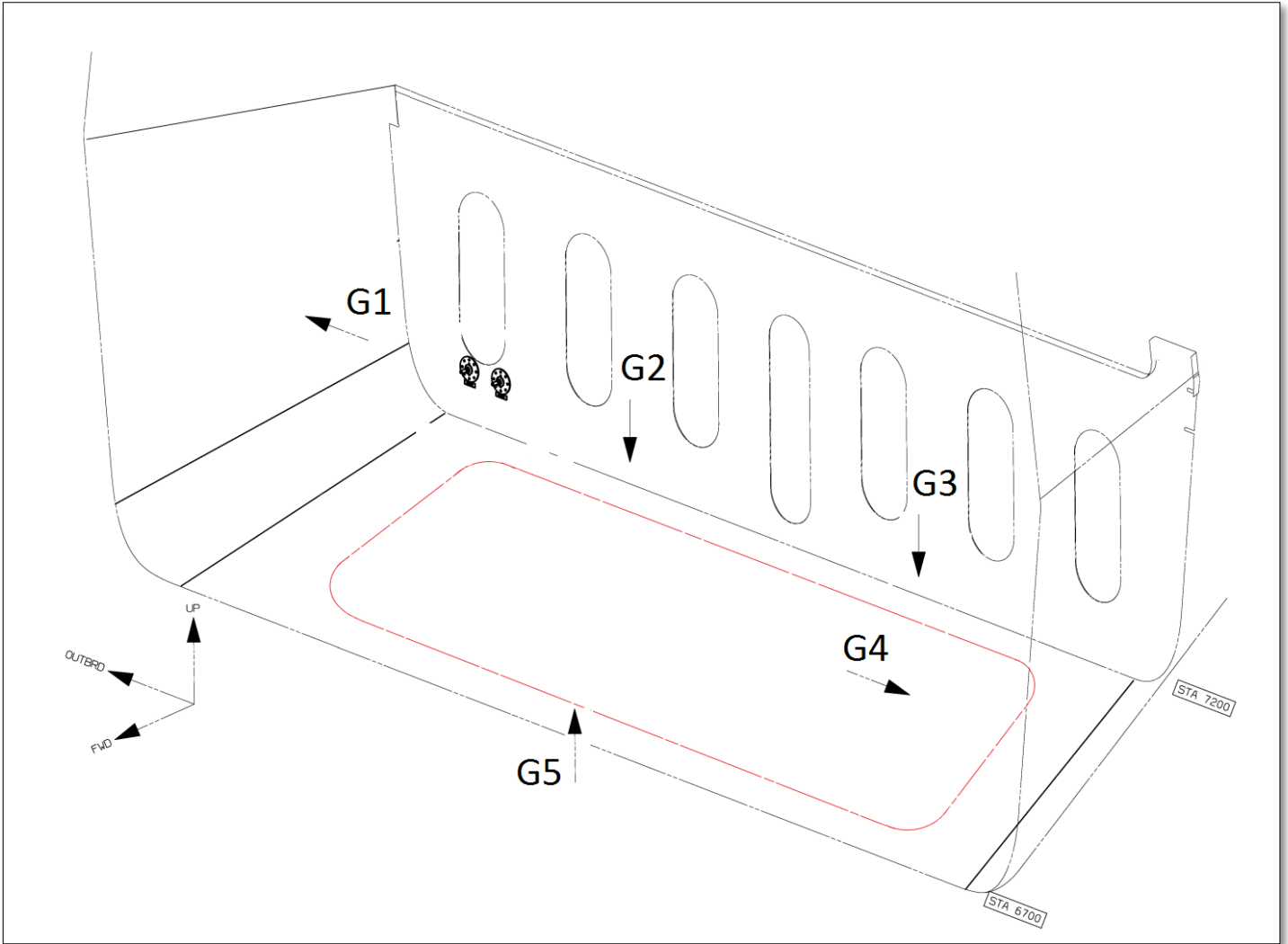

Figure 10 – Clippings Installation



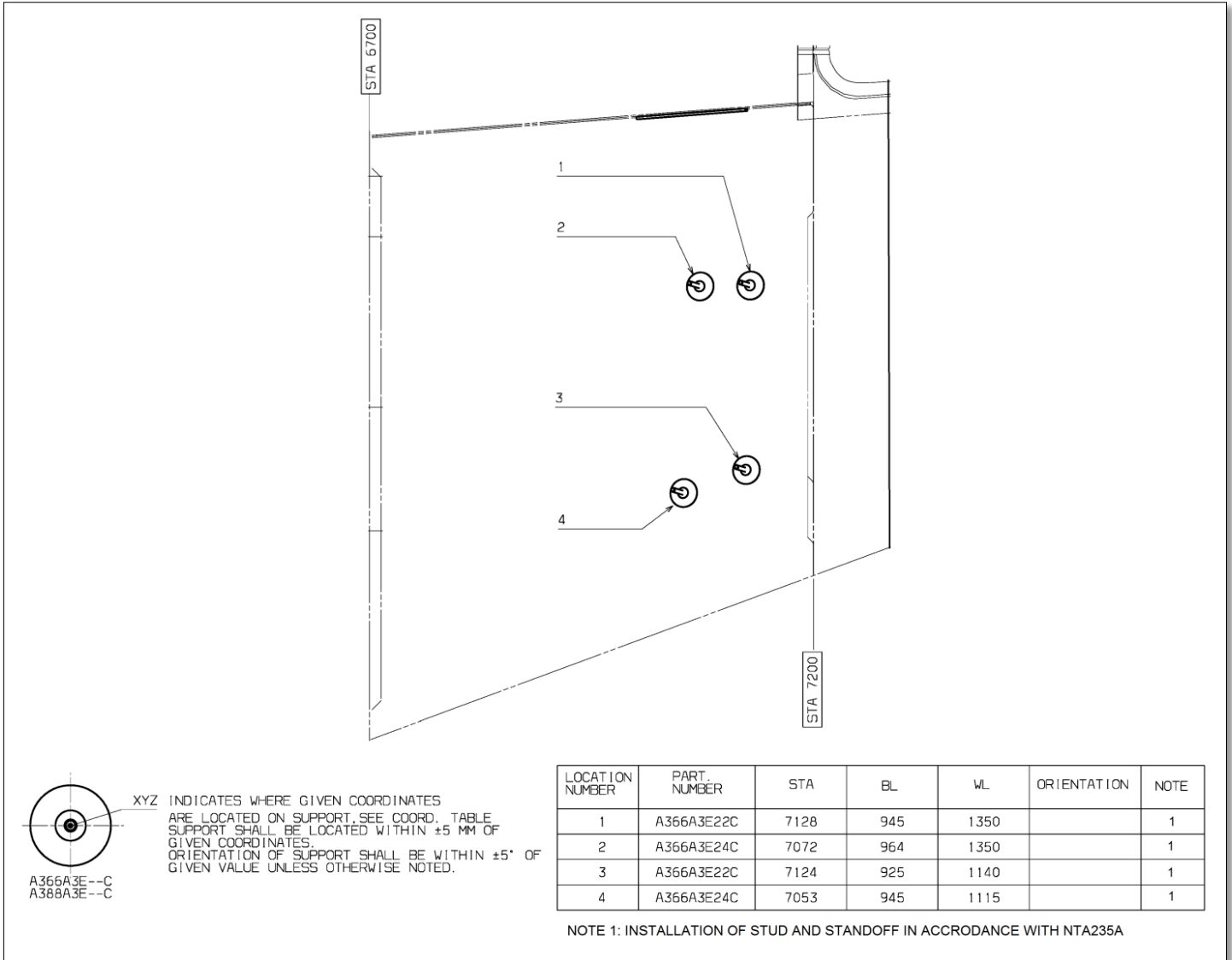

Figure 11 – View G1 - RH Side Wall

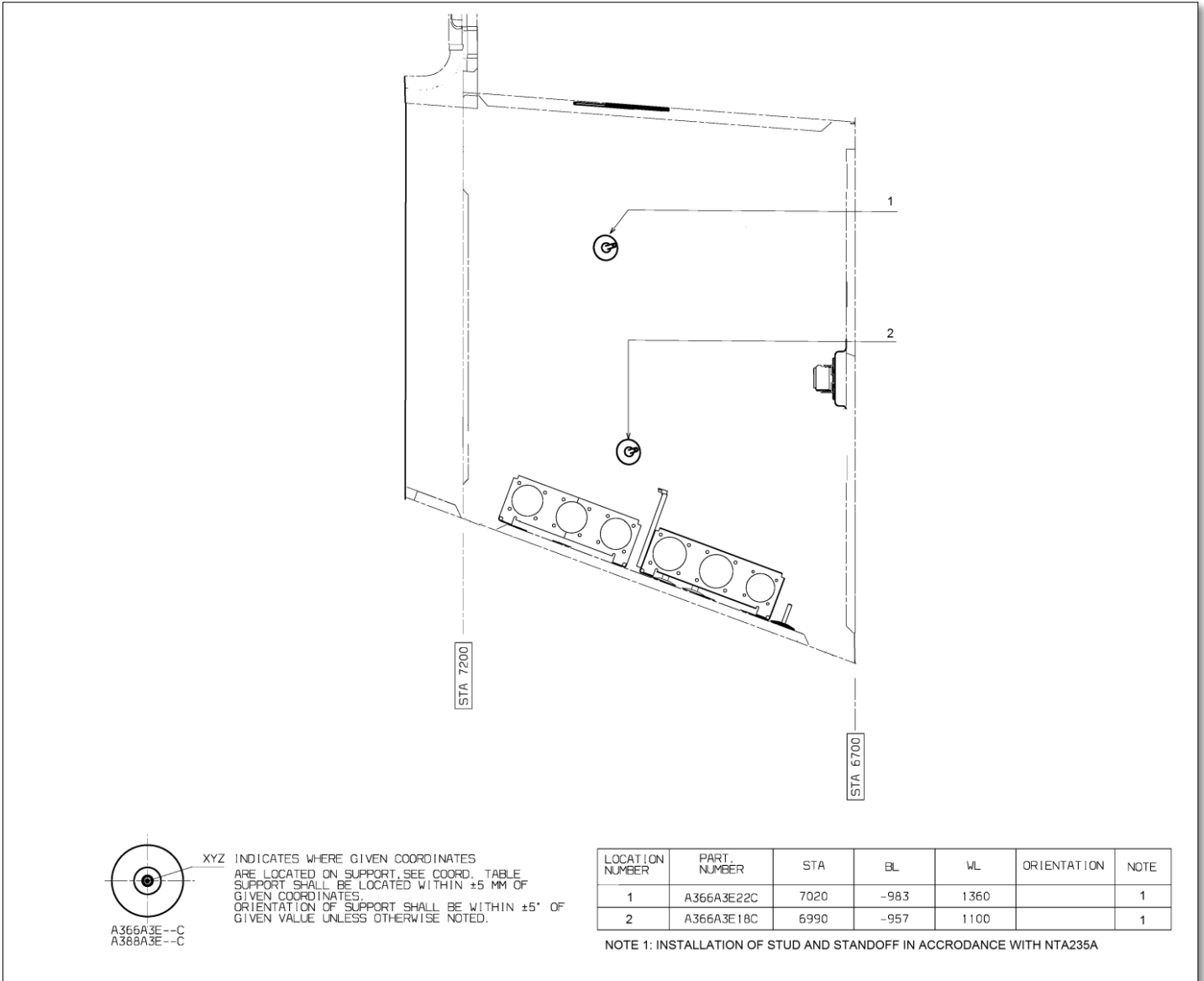

Figure 12 – View G2 – LH Side Wall

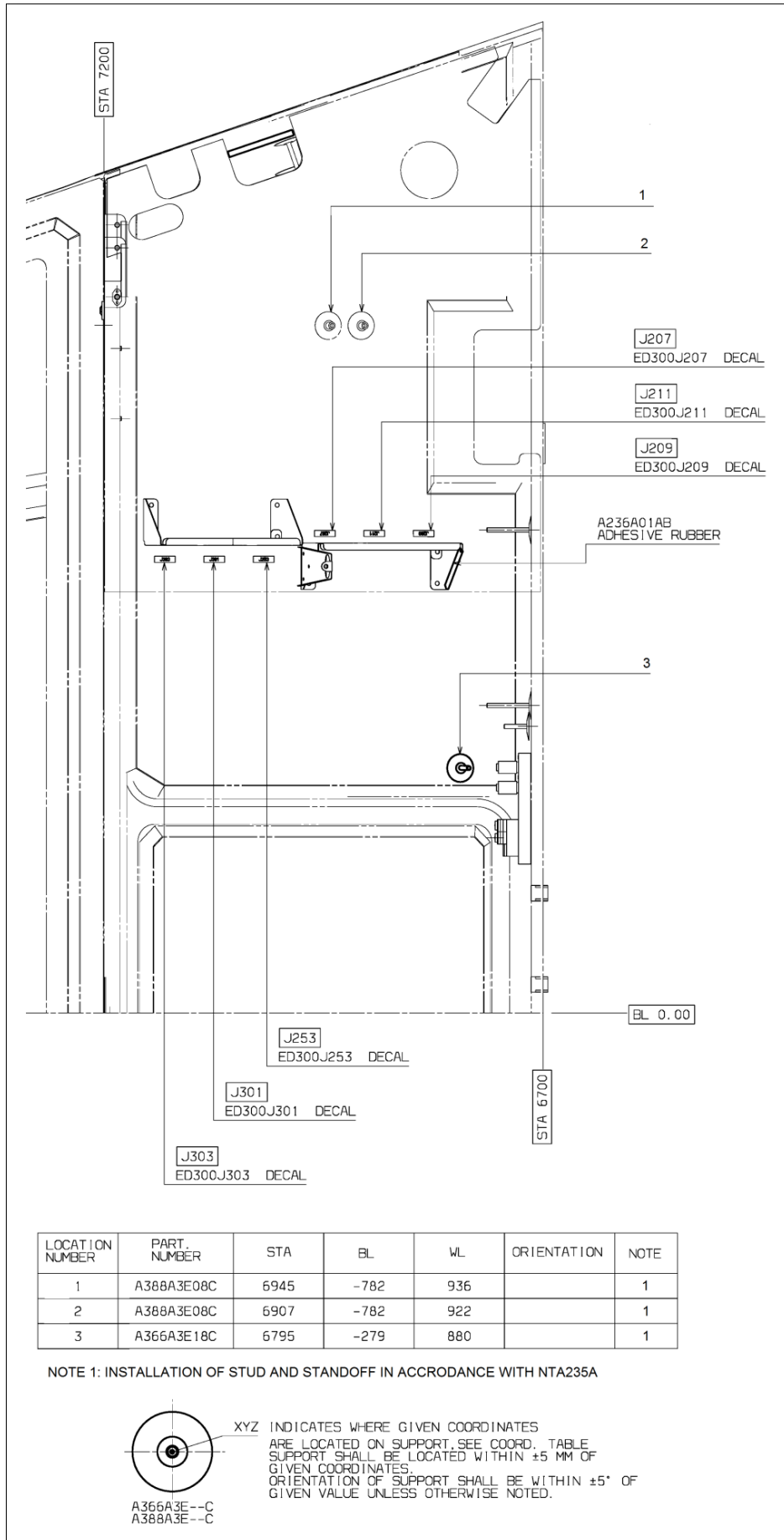

Figure 13 – View G3 – LH Side – Bottom

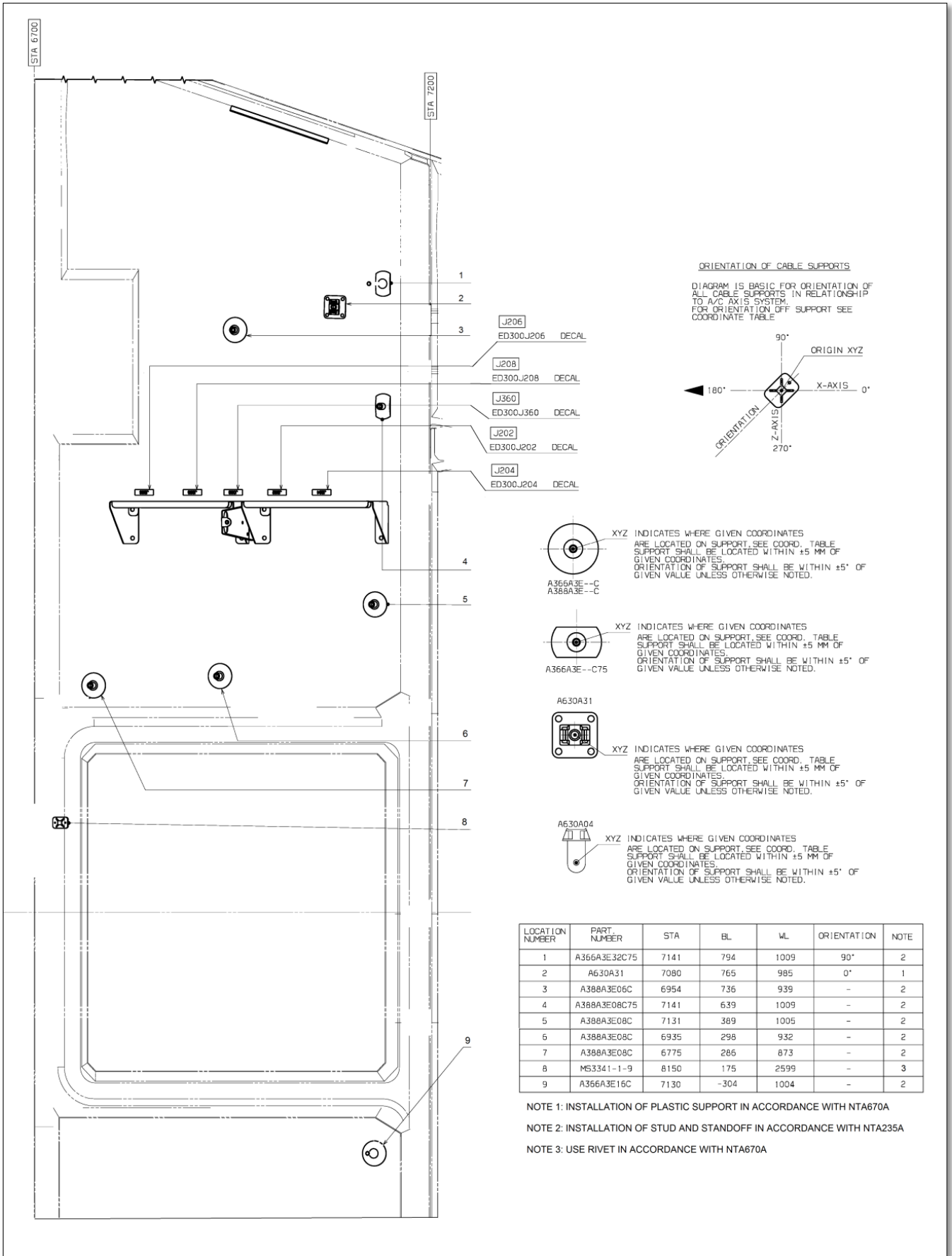

Figure 14 – View G4 – RH Side – Bottom

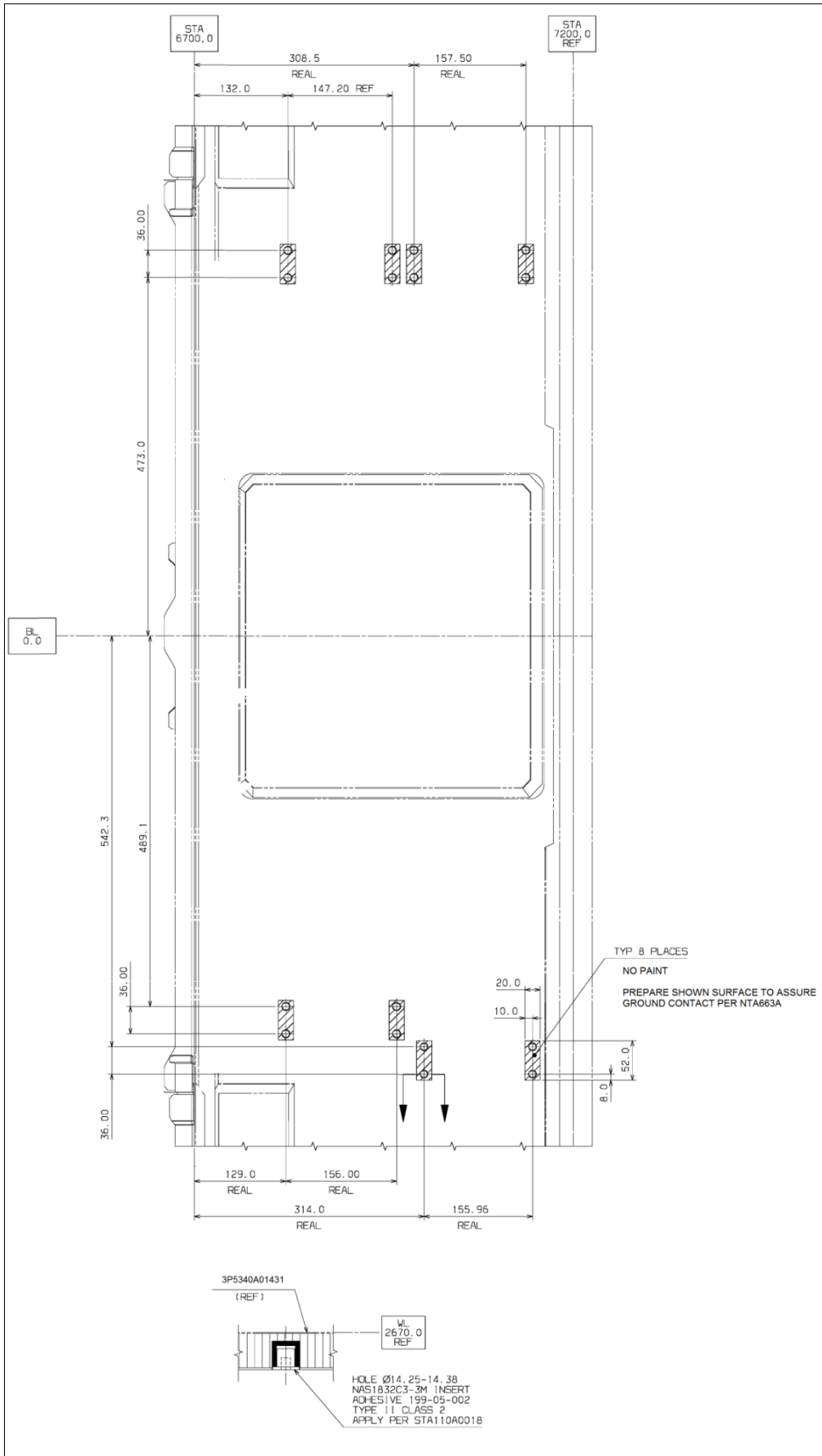

Figure 15 – Detail G5 – Surface Preparation

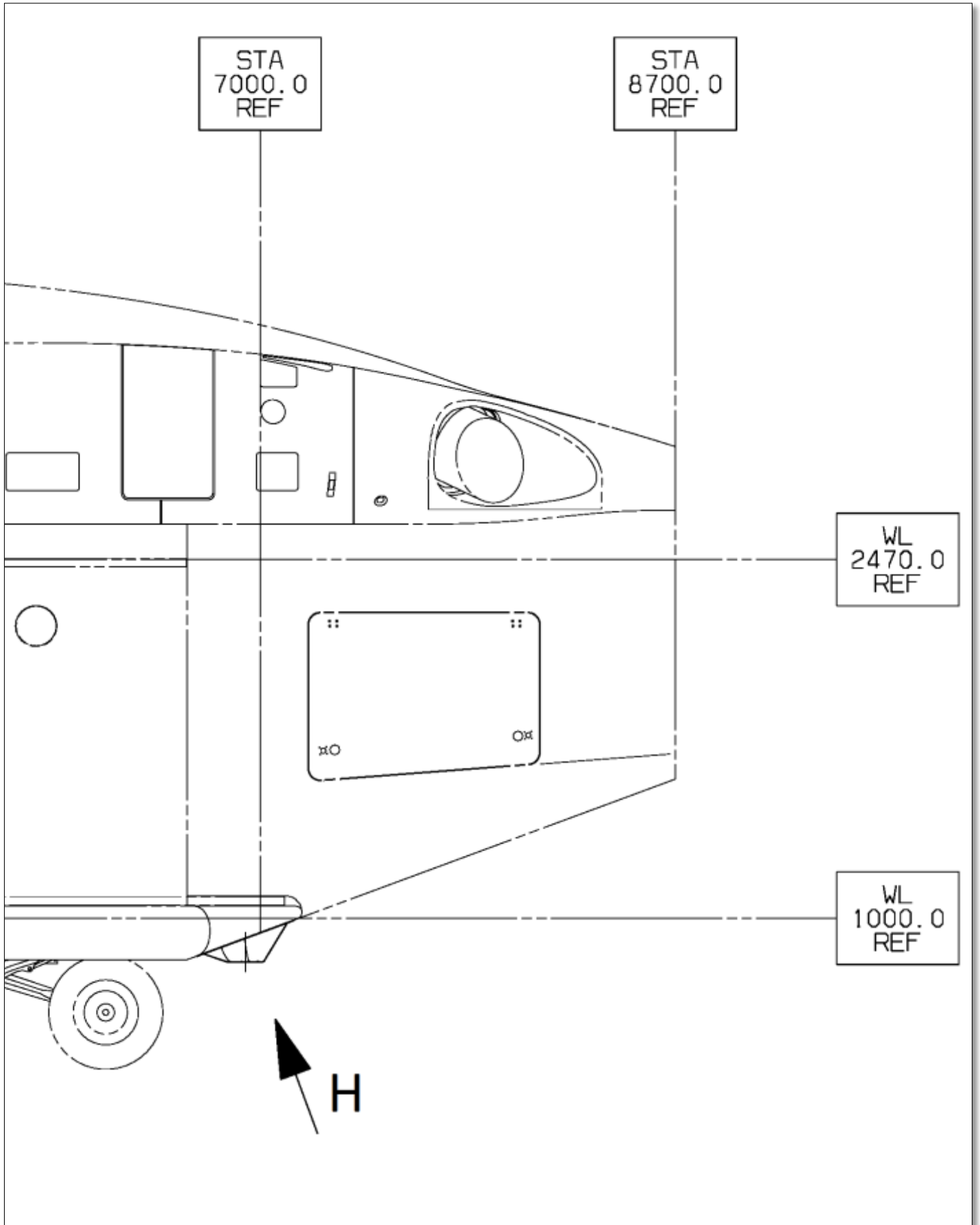

Figure 16 – Detail H and Associated Views (Sheet 1 of 5)

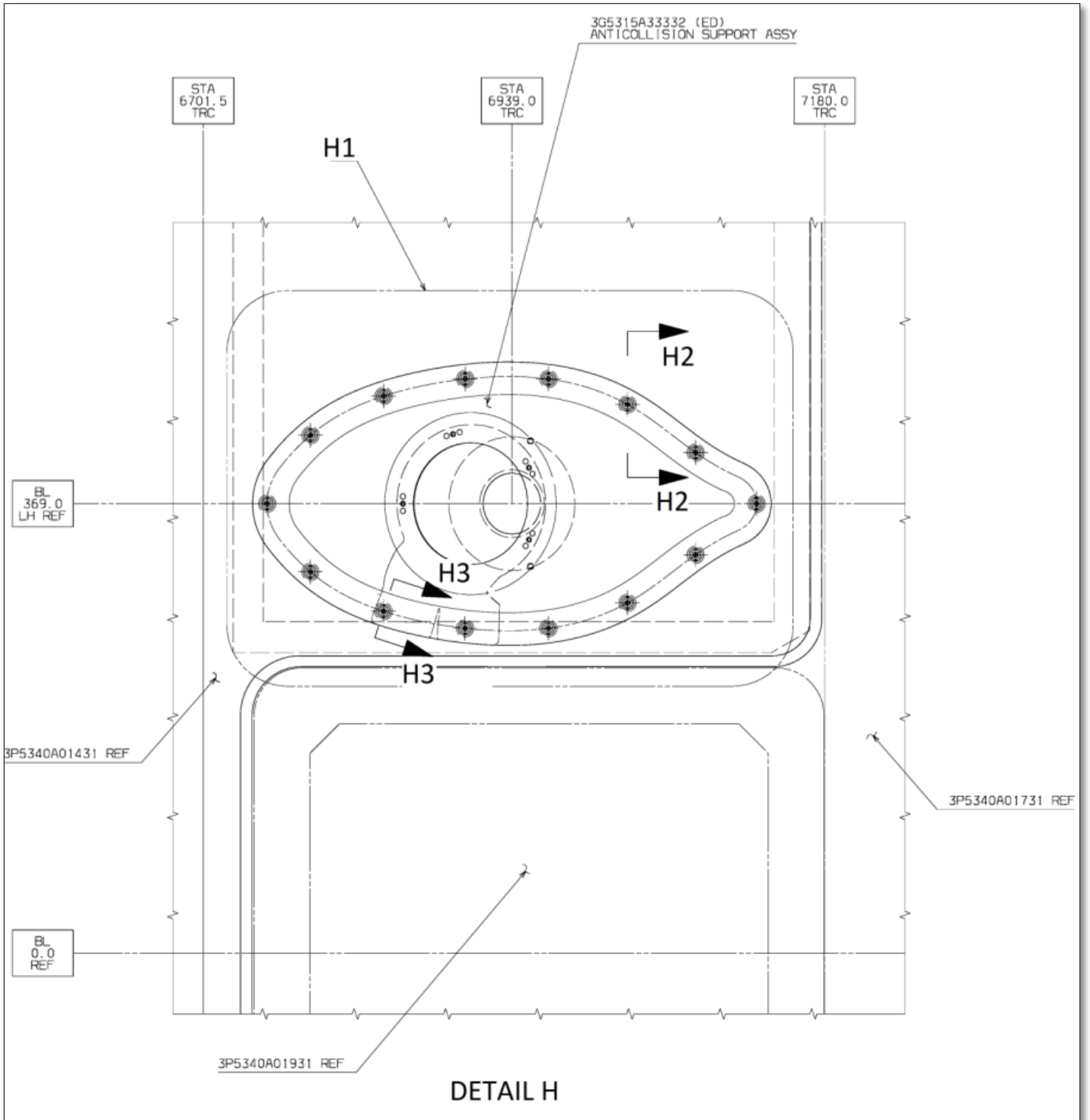

Figure 16 – Detail H and Associated Views (Sheet 2 of 5)

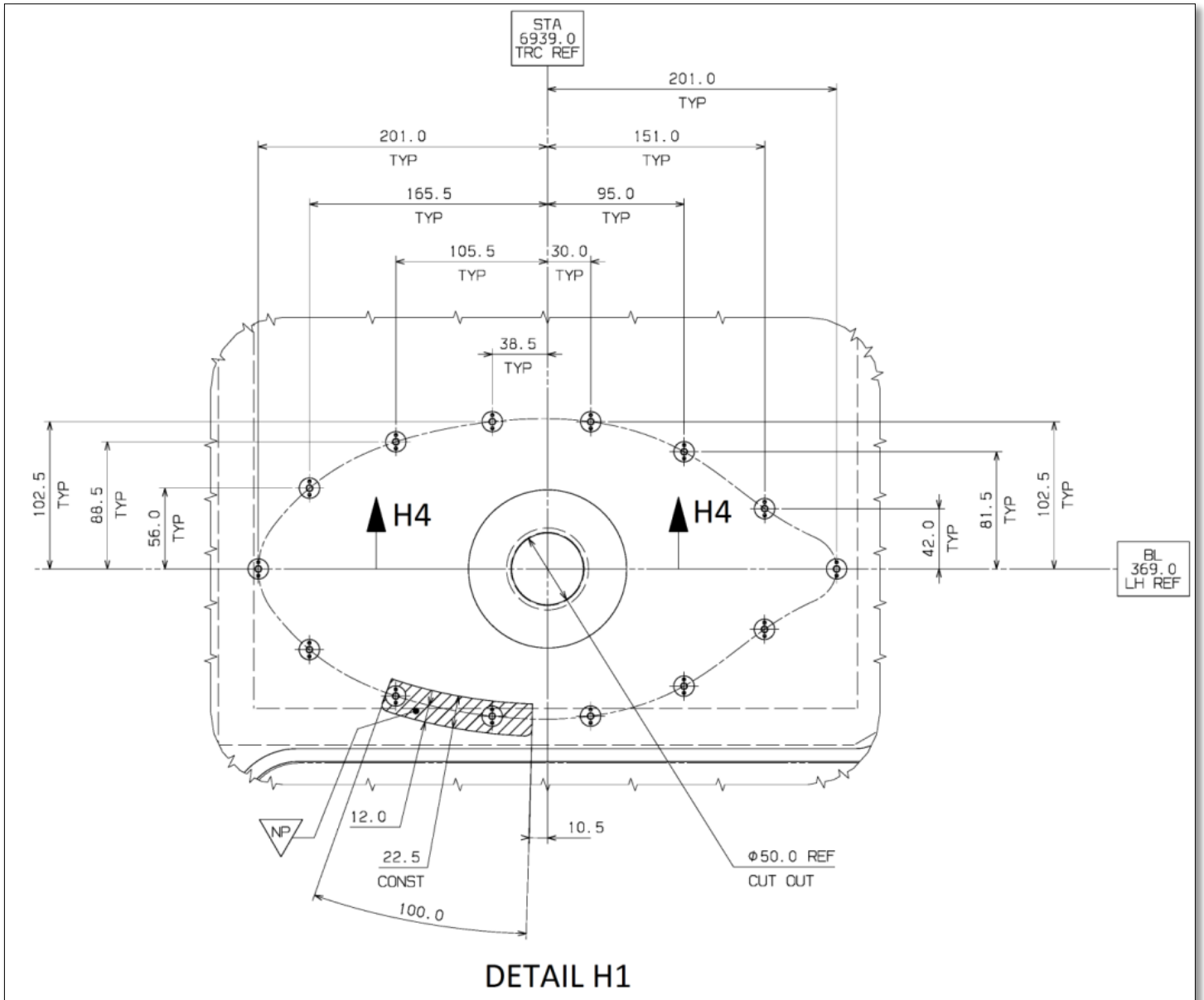
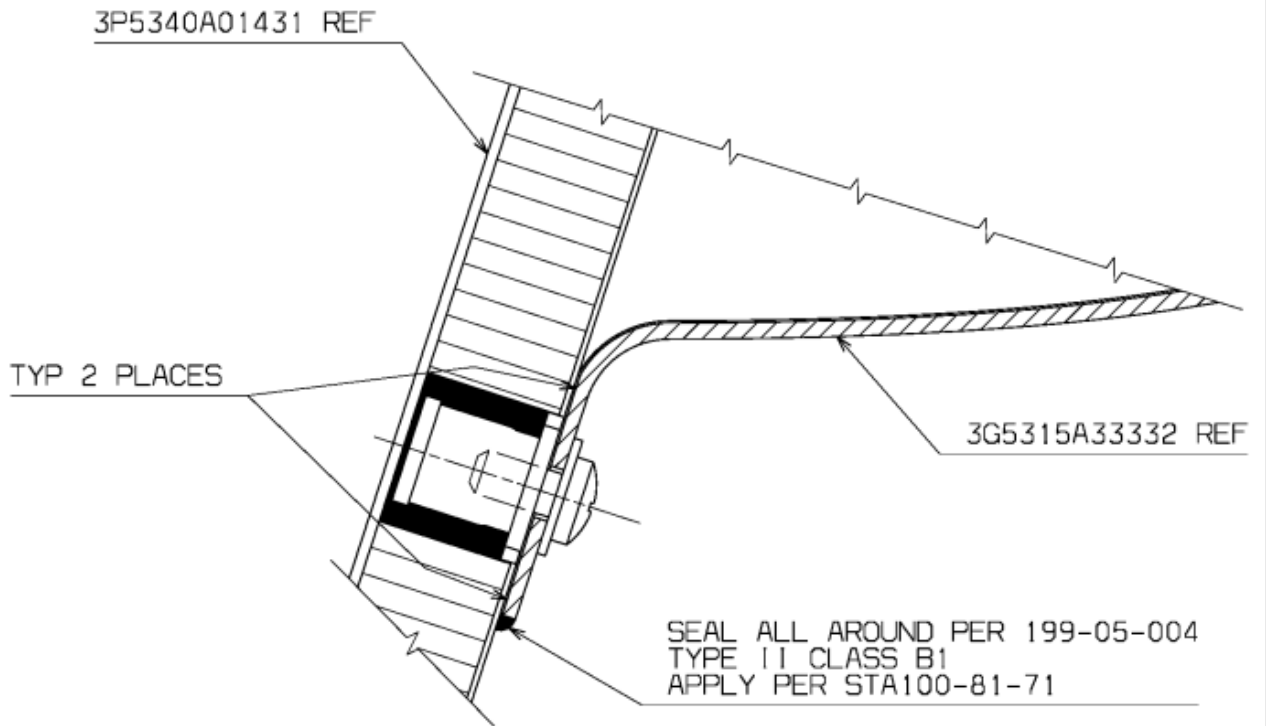
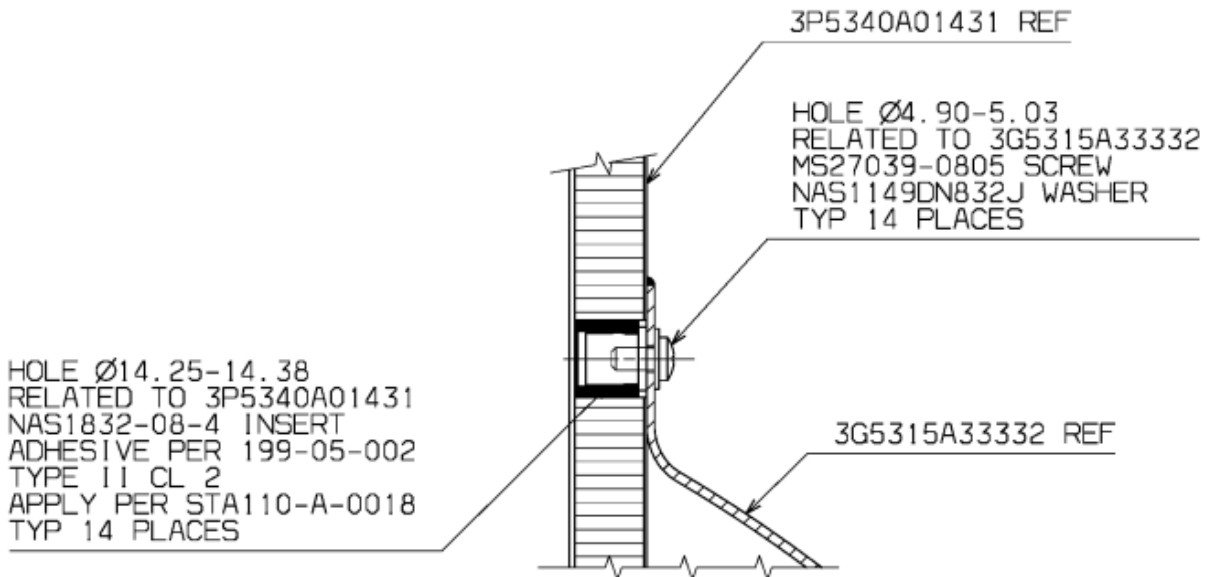

Figure 16 – Detail H and Associated Views (Sheet 3 of 5)





### SECTION H3-H3



### SECTION H2-H2

Figure 16 – Detail H and Associated Views (Sheet 4 of 5)

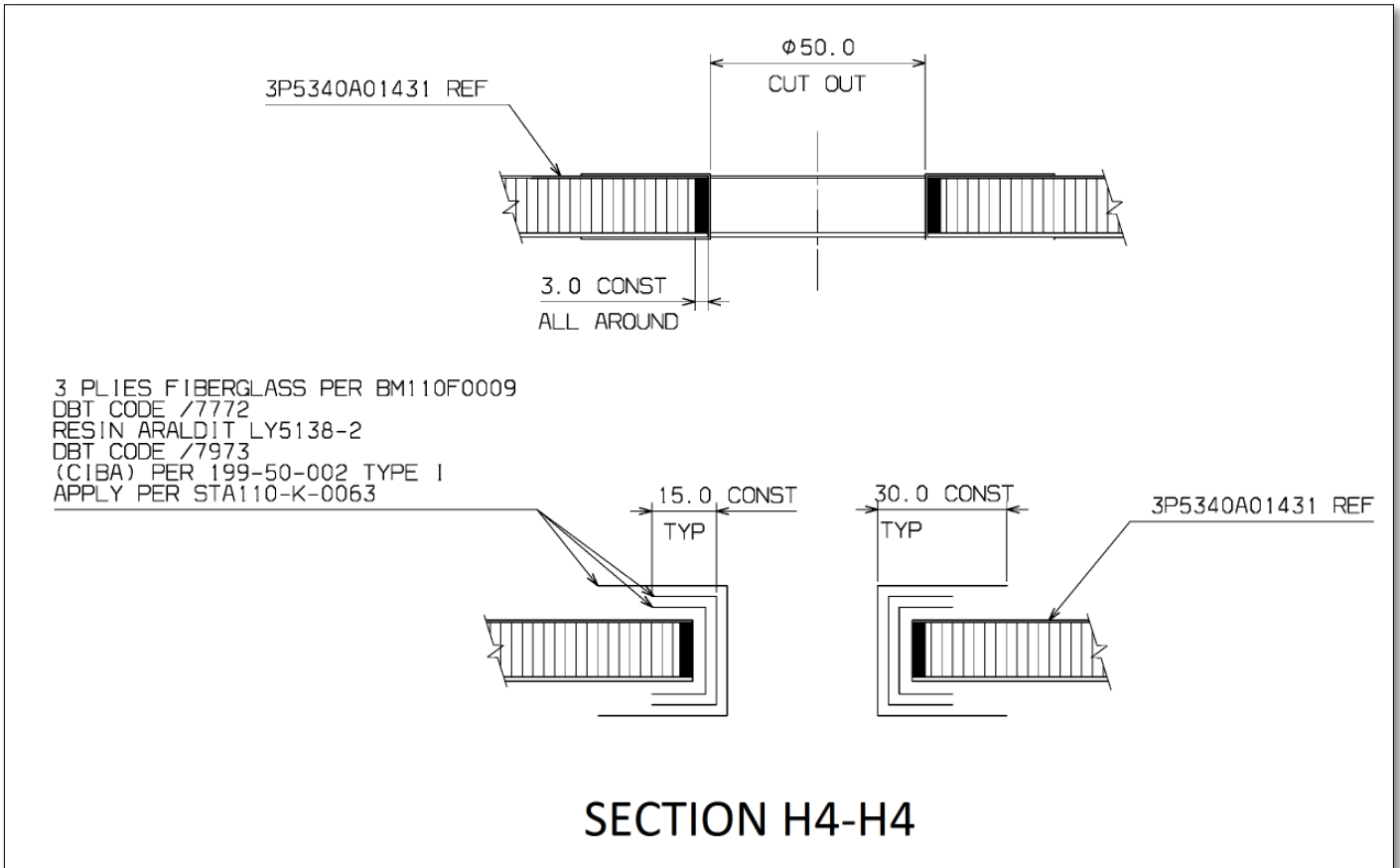

Figure 16 – Detail H and Associated Views (Sheet 5 of 5)

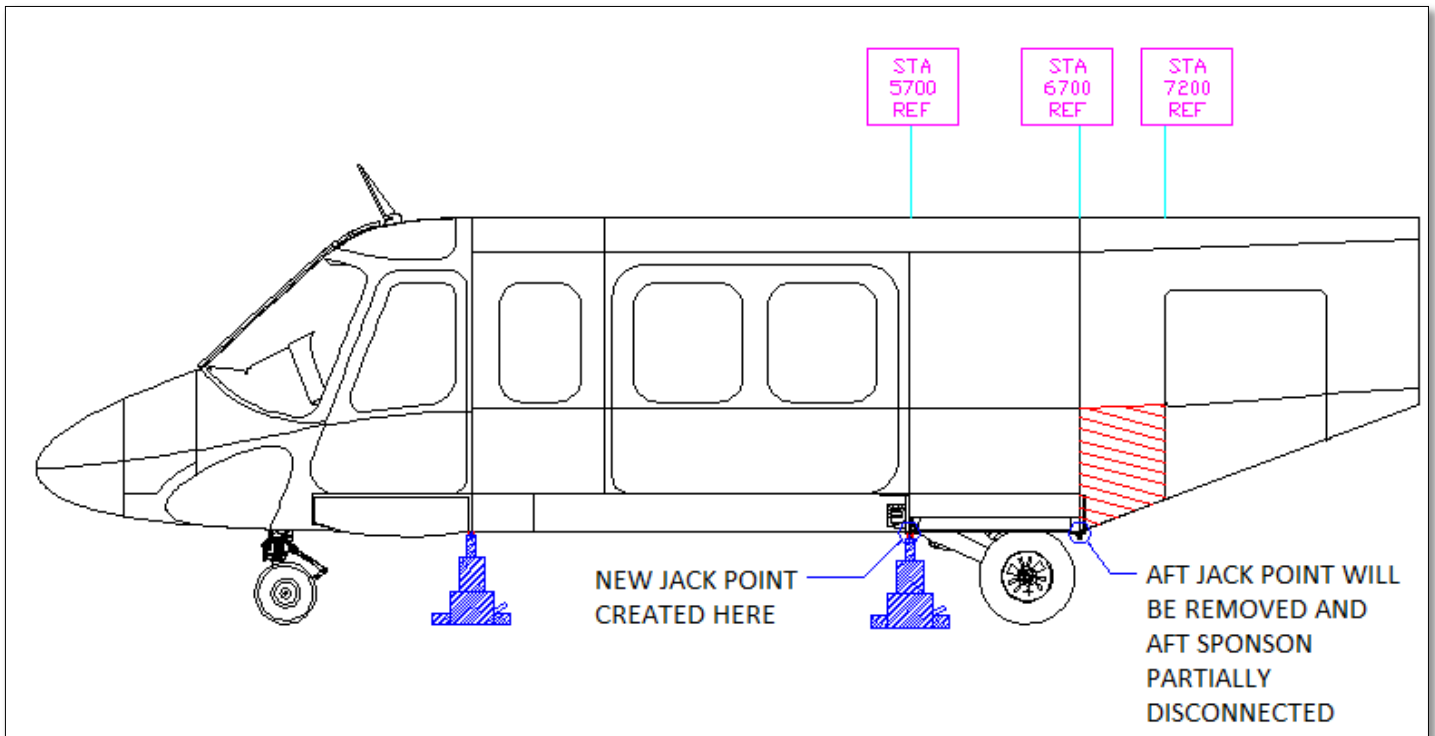

Figure 17 – View I – Alternate Jacking Points (Sheet 1 of 2)

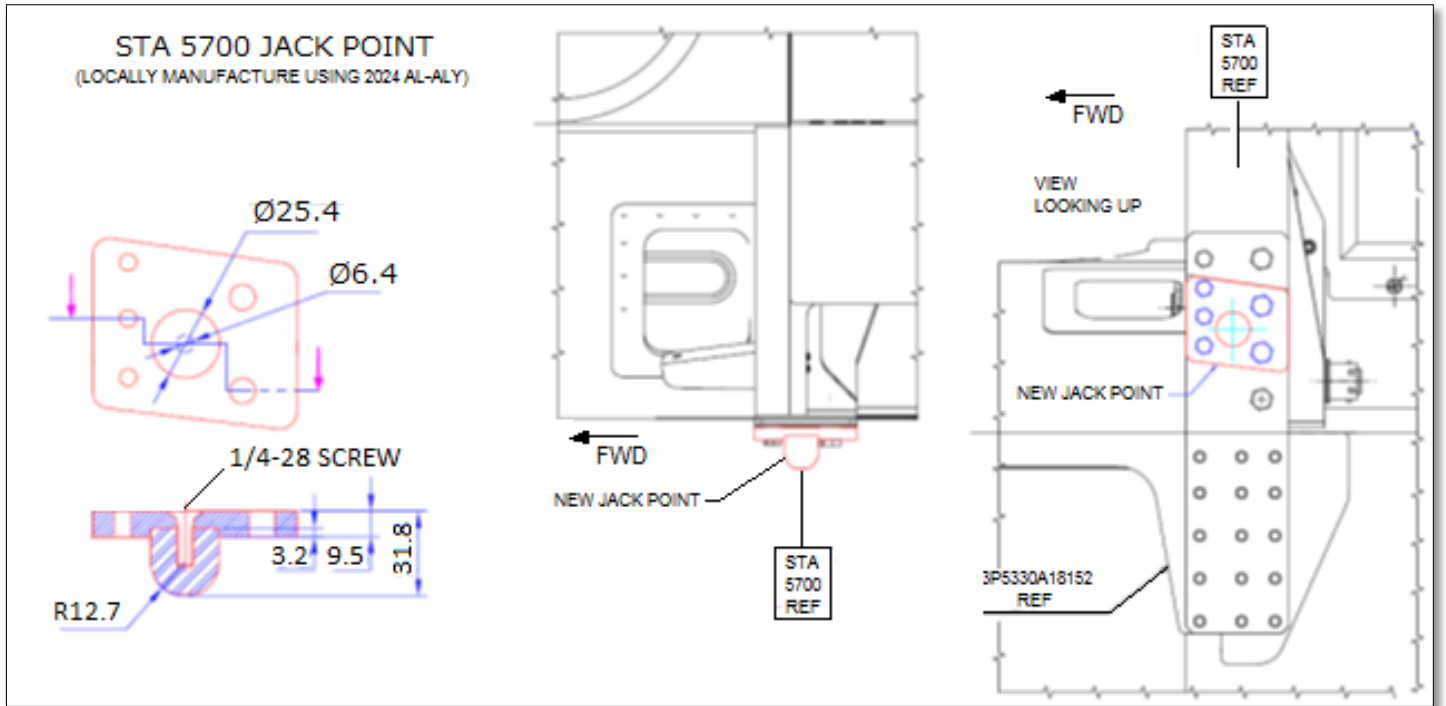

Figure 17 – View I – Alternate Jacking Points (Sheet 2 of 2)



Figure 18 – Forward Lower Panel Assembly Installed (Sheet 1 of 2)



Figure 18 – Forward Lower Panel Assembly Installed (Sheet 2 of 2)

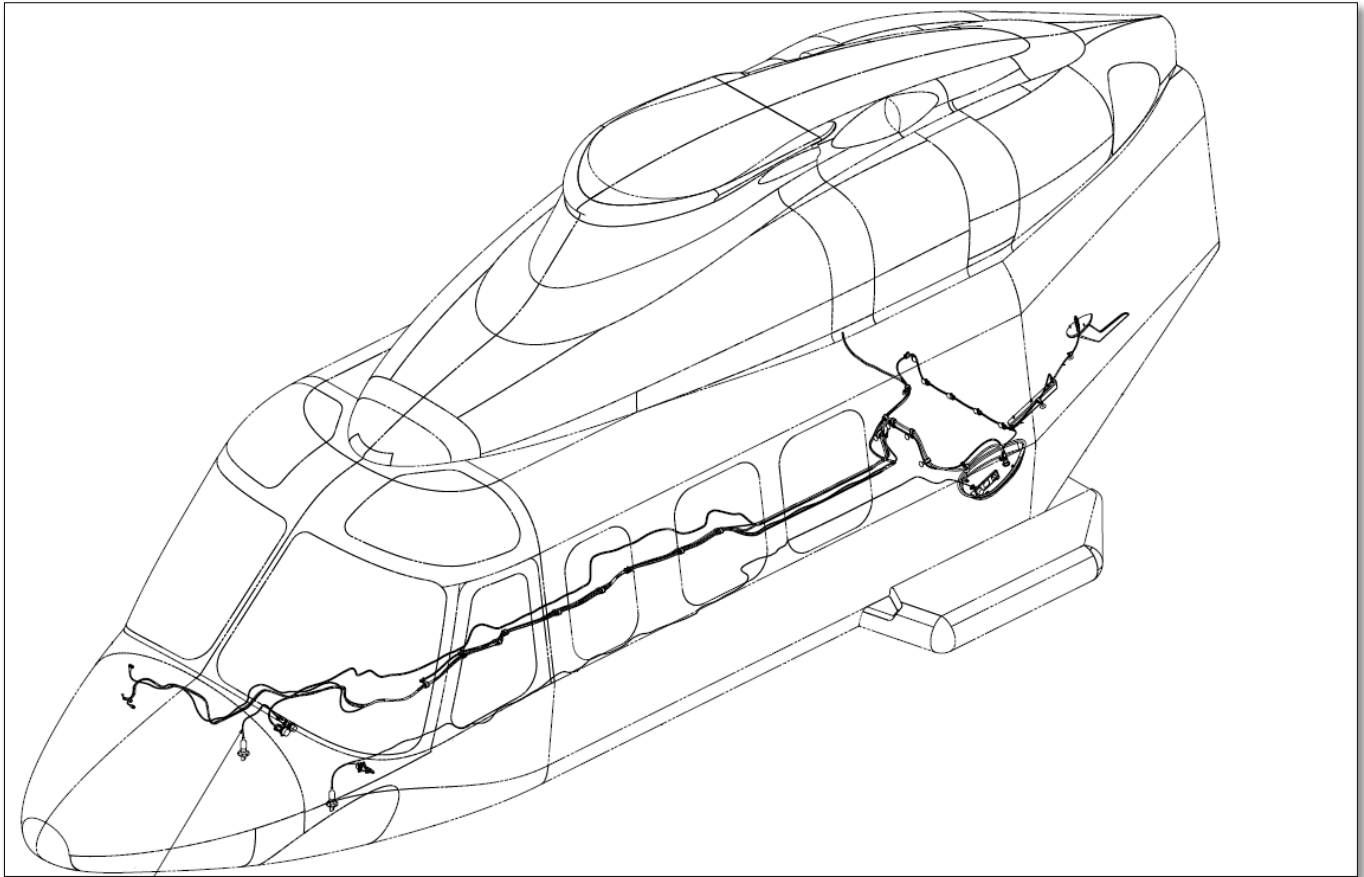

Figure 19 – ADF Antenna Location (Sheet 1 of 2)

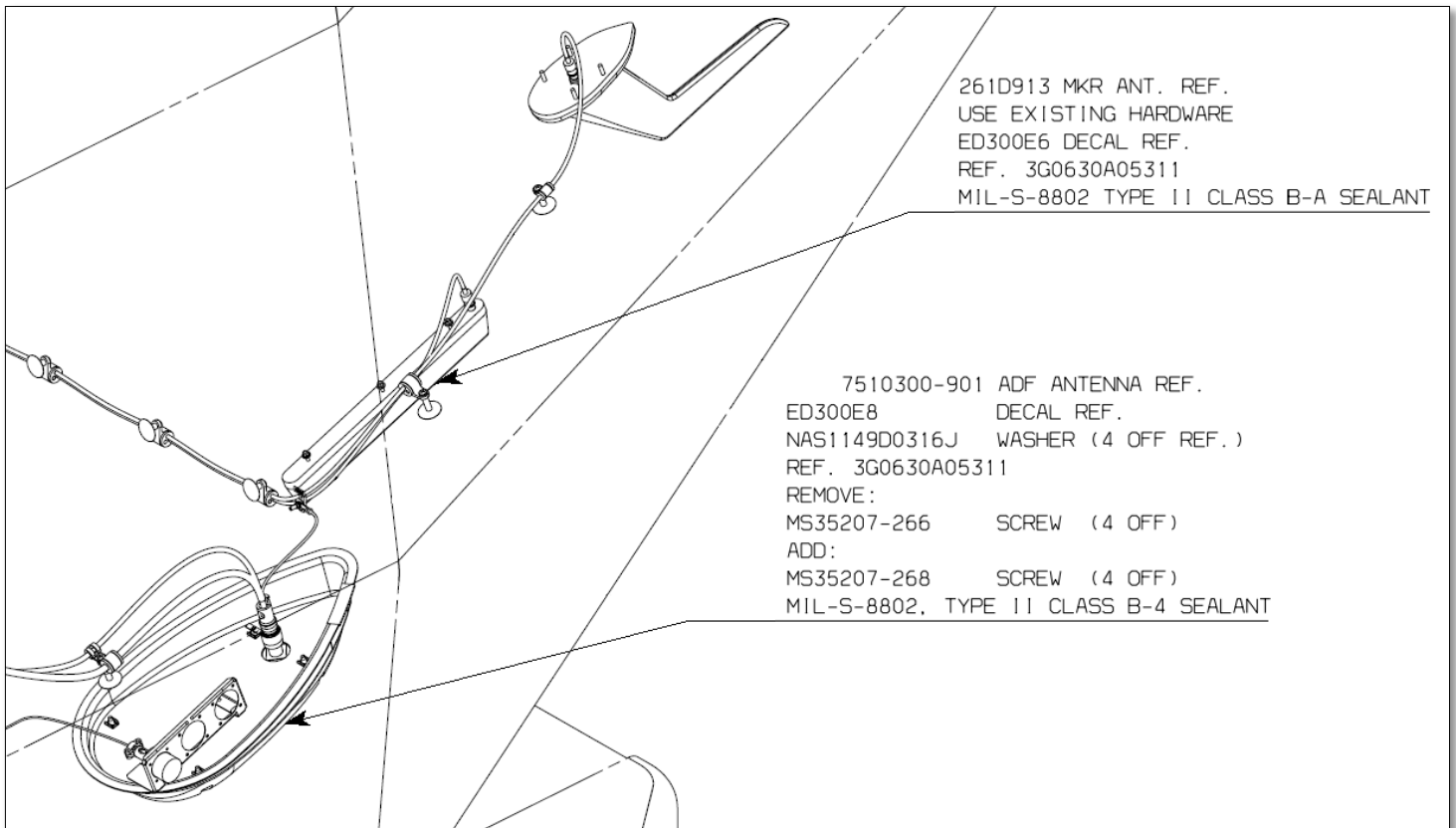

Figure 19 – ADF Antenna Location (Sheet 2 of 2)



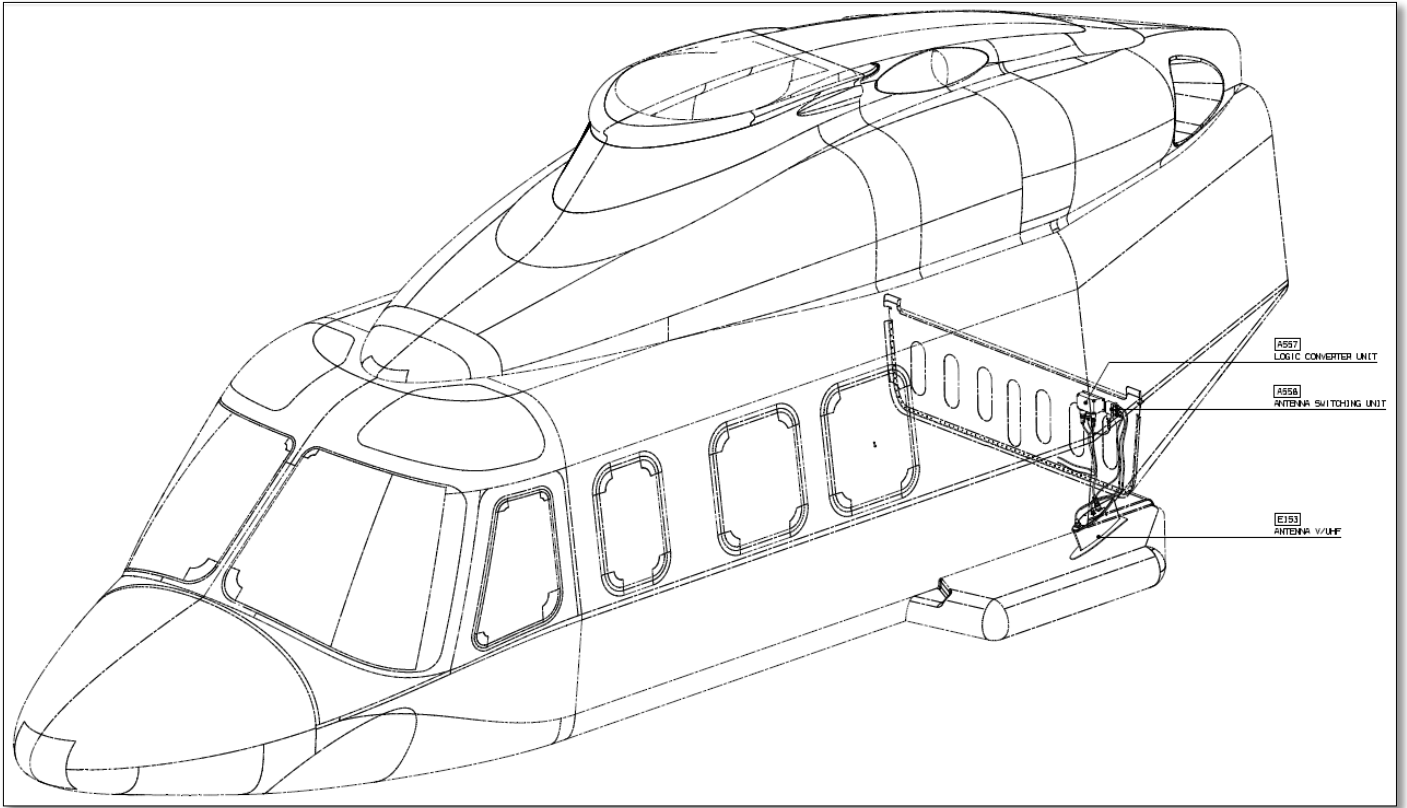

Figure 20 – RT7000 V/UHF Antenna Location (Sheet 1 of 2)



Figure 20 – RT700 V/UHF Antenna Location (Sheet 2 of 2)

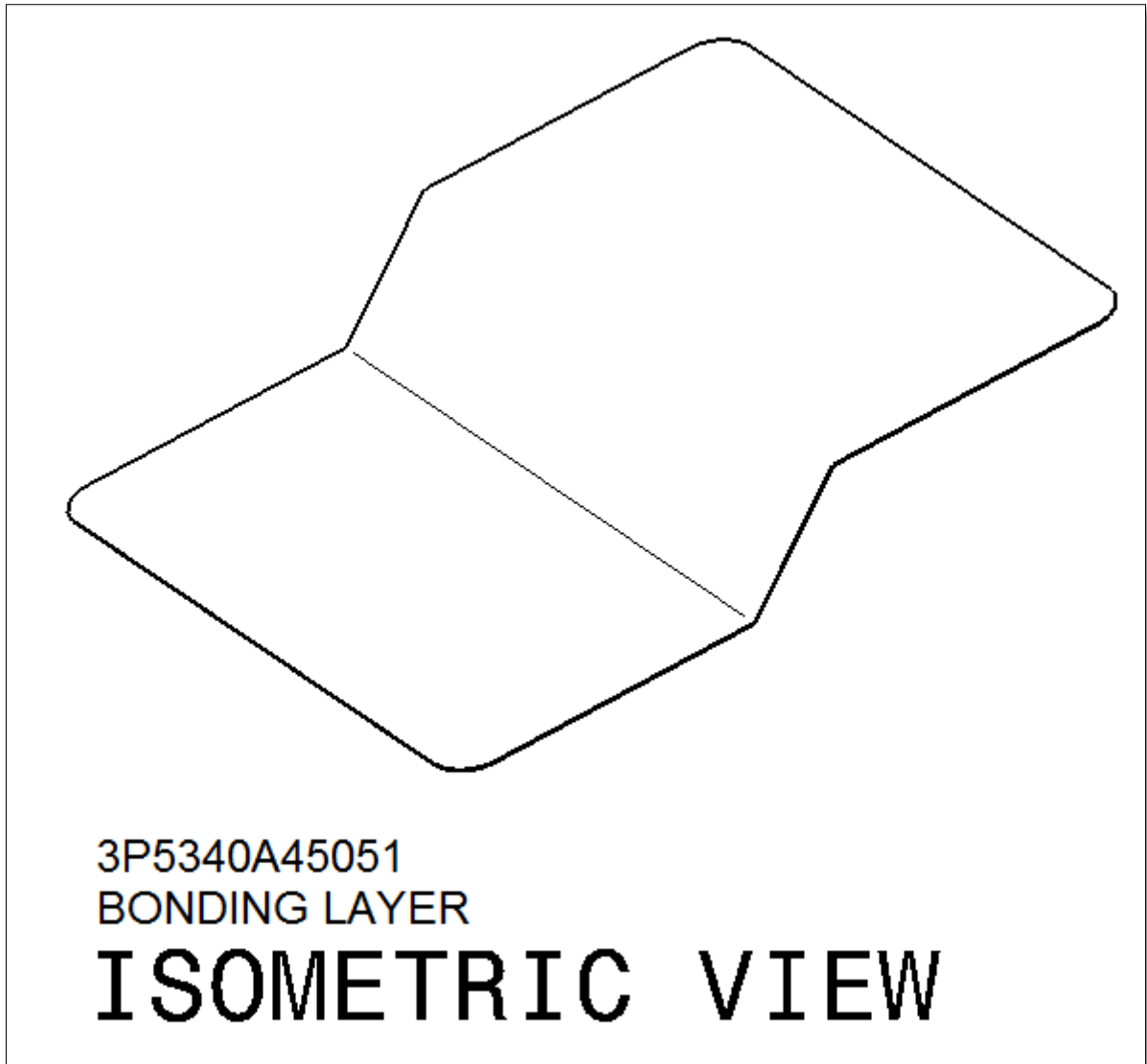

Figure 21 – Bonding Layer P/N: 3P5340A45051 Installation (Sheet 1 of 9)

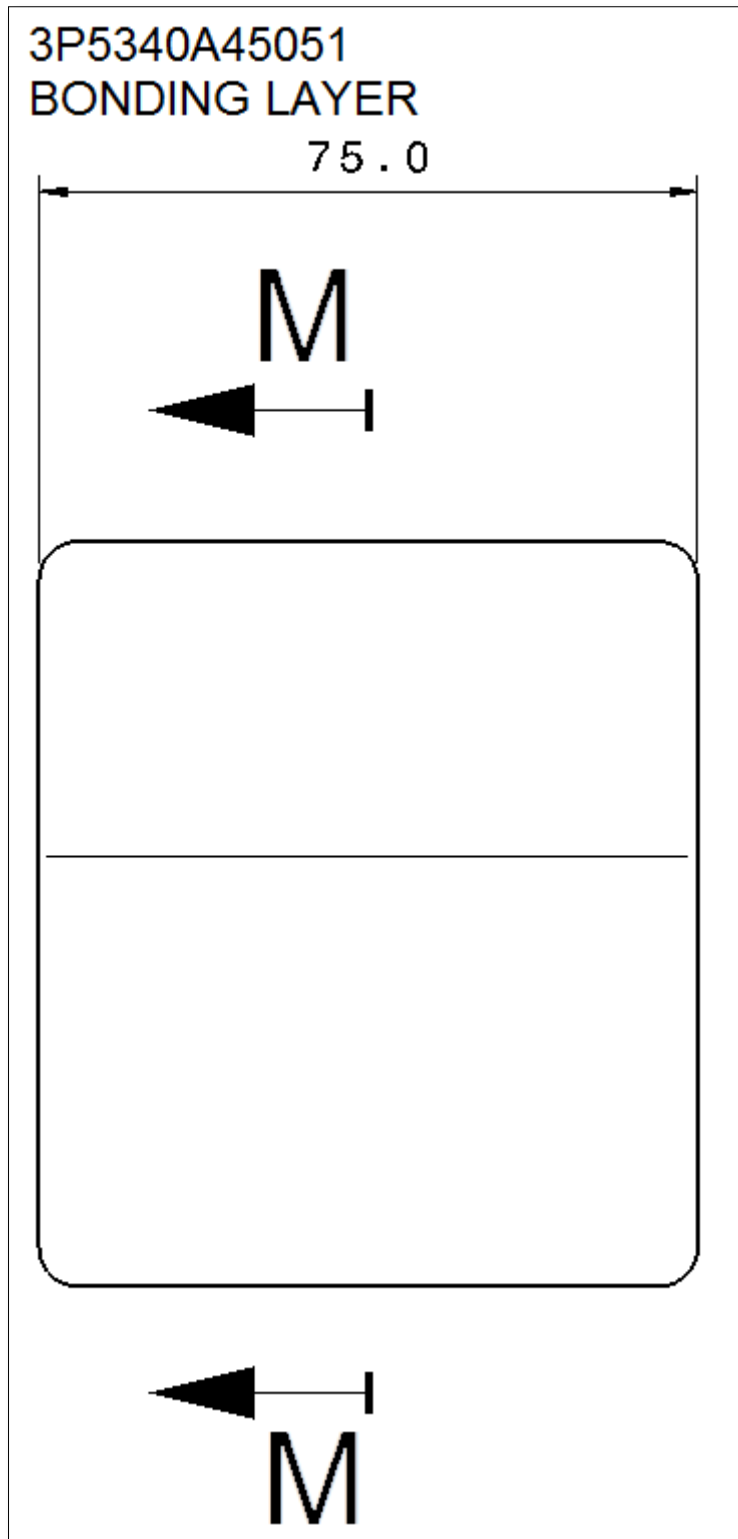

Figure 21 – Bonding Layer P/N: 3P5340A45051 Installation (Sheet 2 of 9)



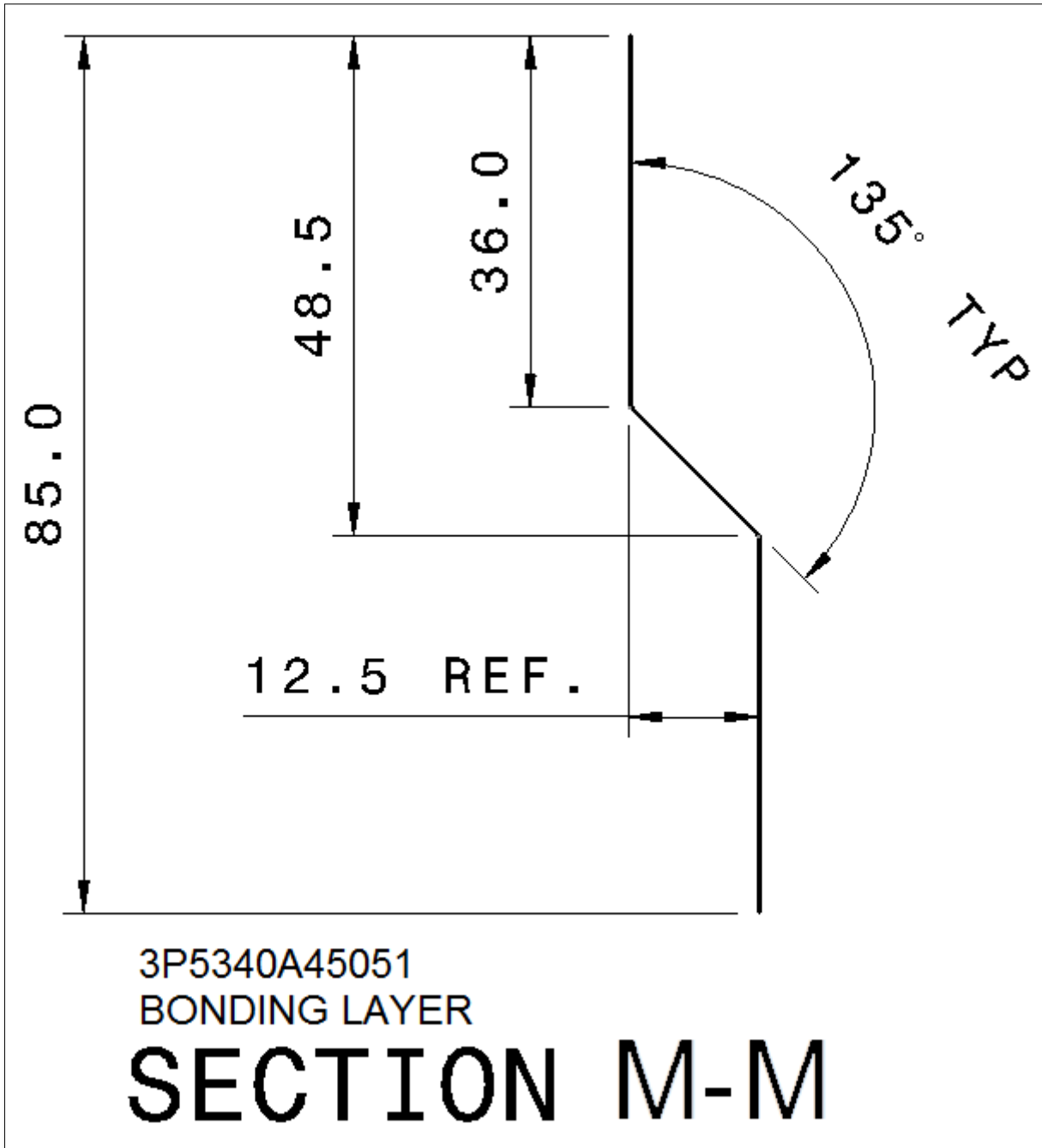

Figure 21 – Bonding Layer P/N: 3P5340A45051 Installation (Sheet 3 of 9)

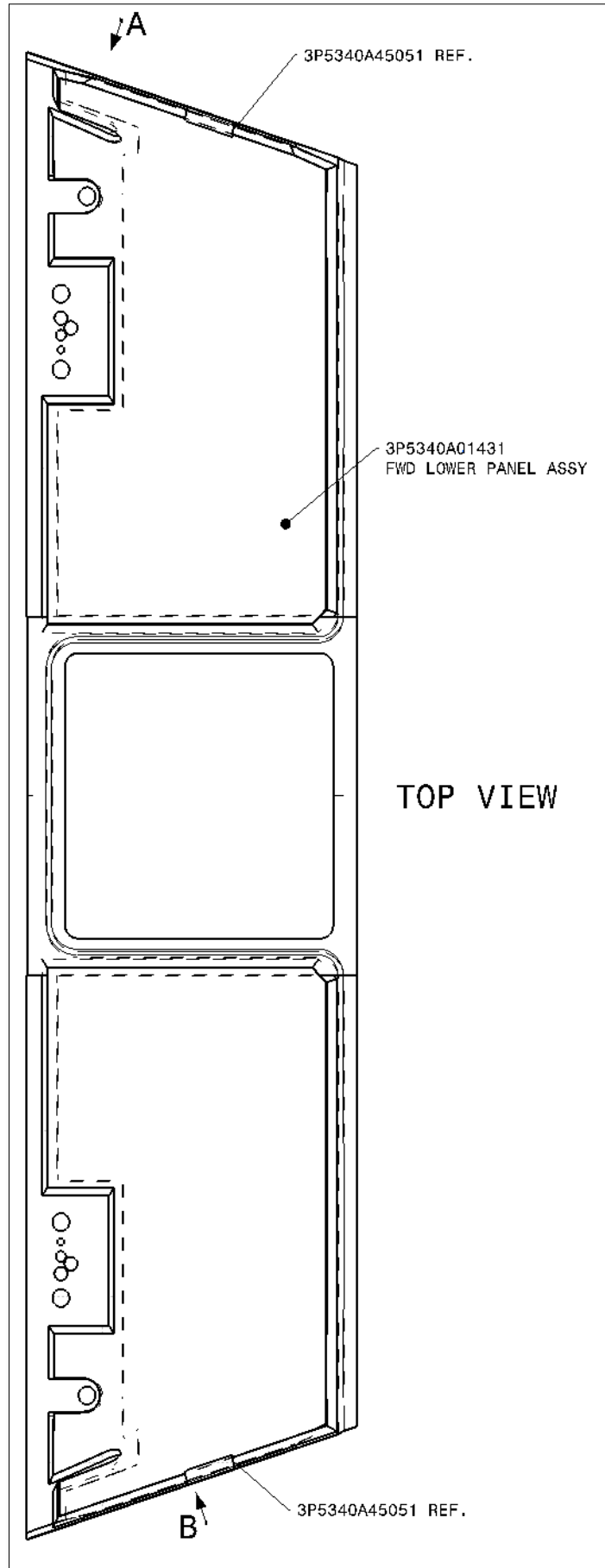

Figure 21 – Bonding Layer P/N: 3P5340A45051 Installation (Sheet 4 of 9)

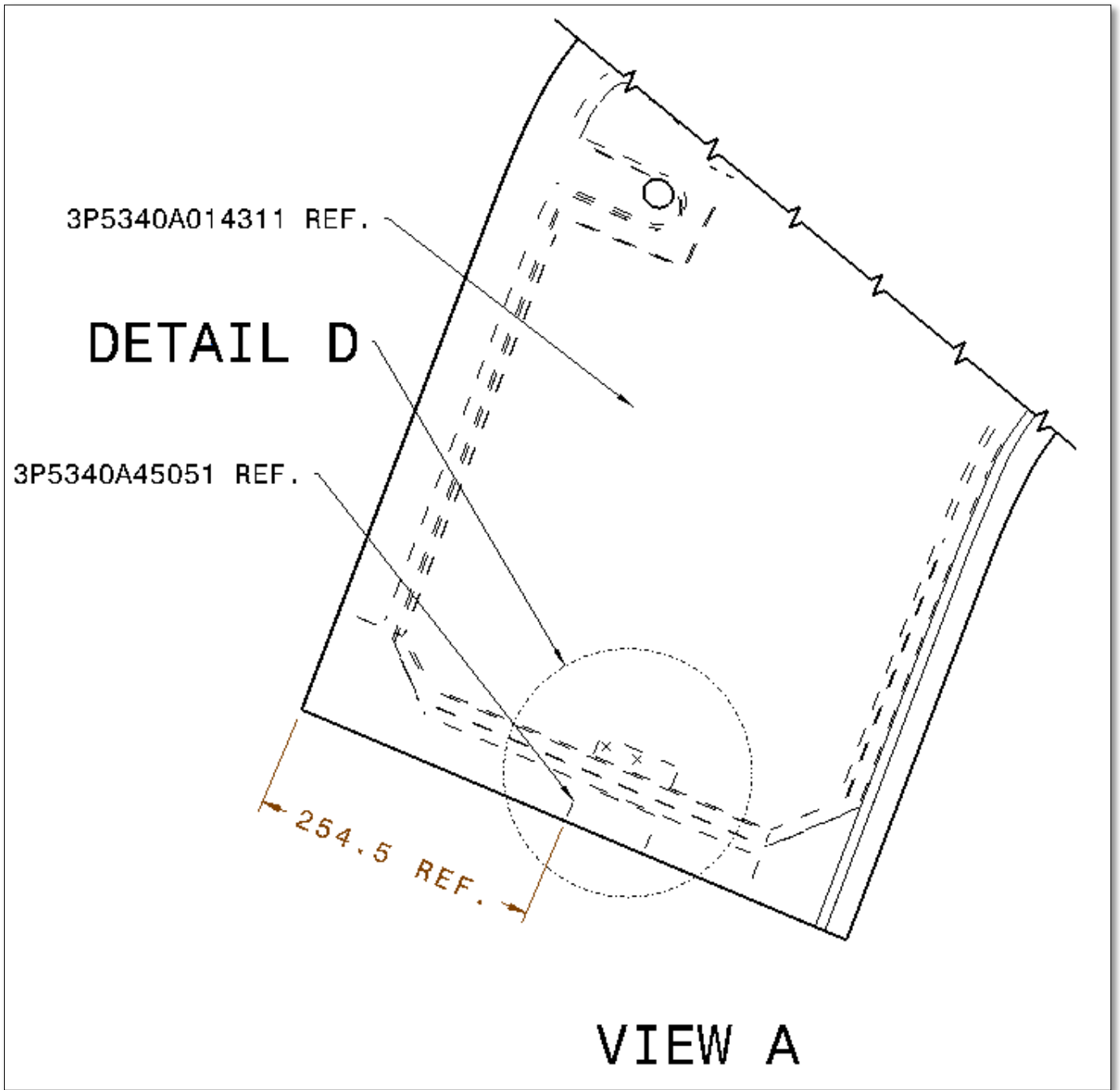

Figure 21 – Bonding Layer P/N: 3P5340A45051 Installation (Sheet 5 of 9)

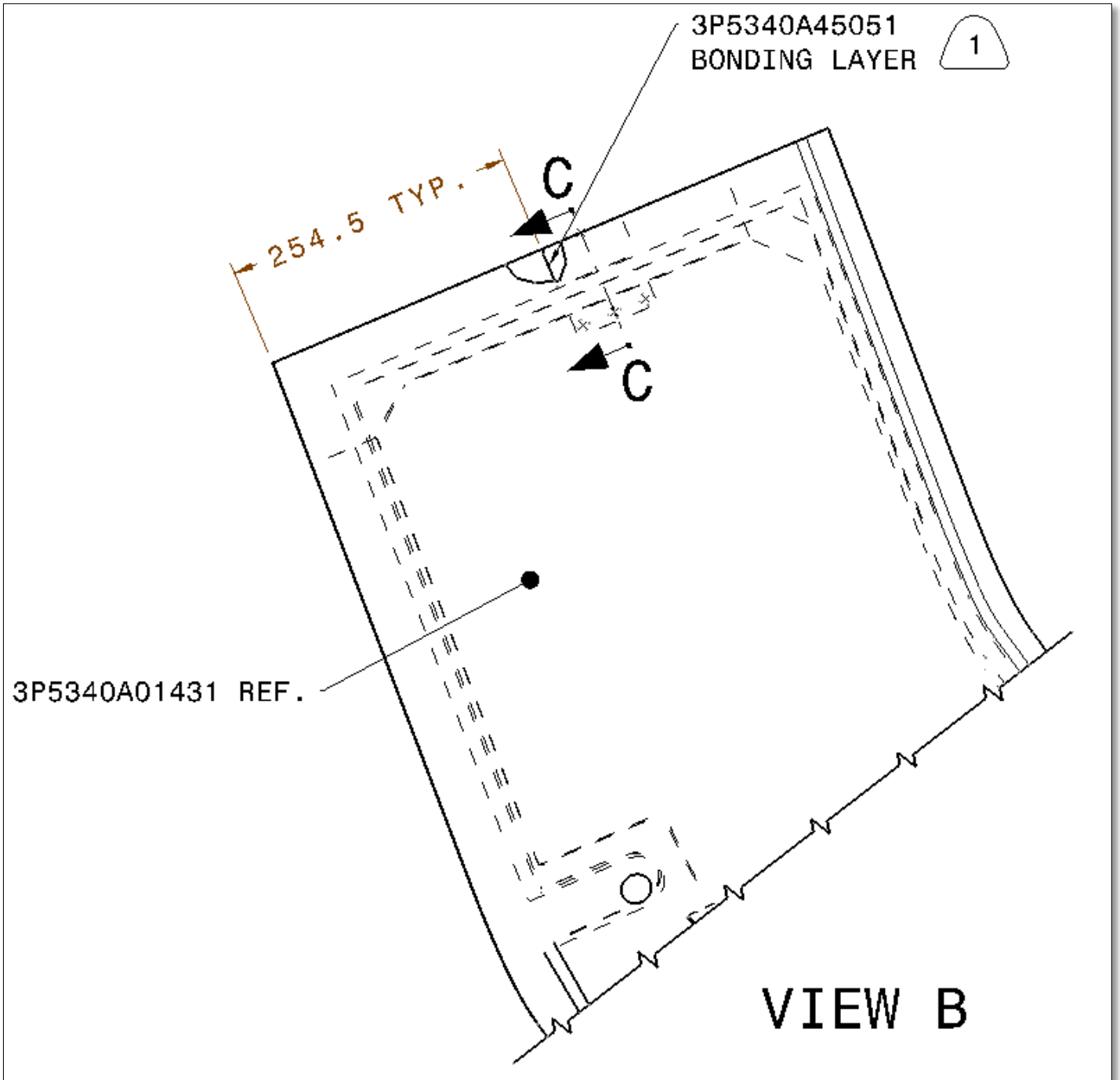

Figure 21 – Bonding Layer P/N: 3P5340A45051 Installation (Sheet 6 of 9)

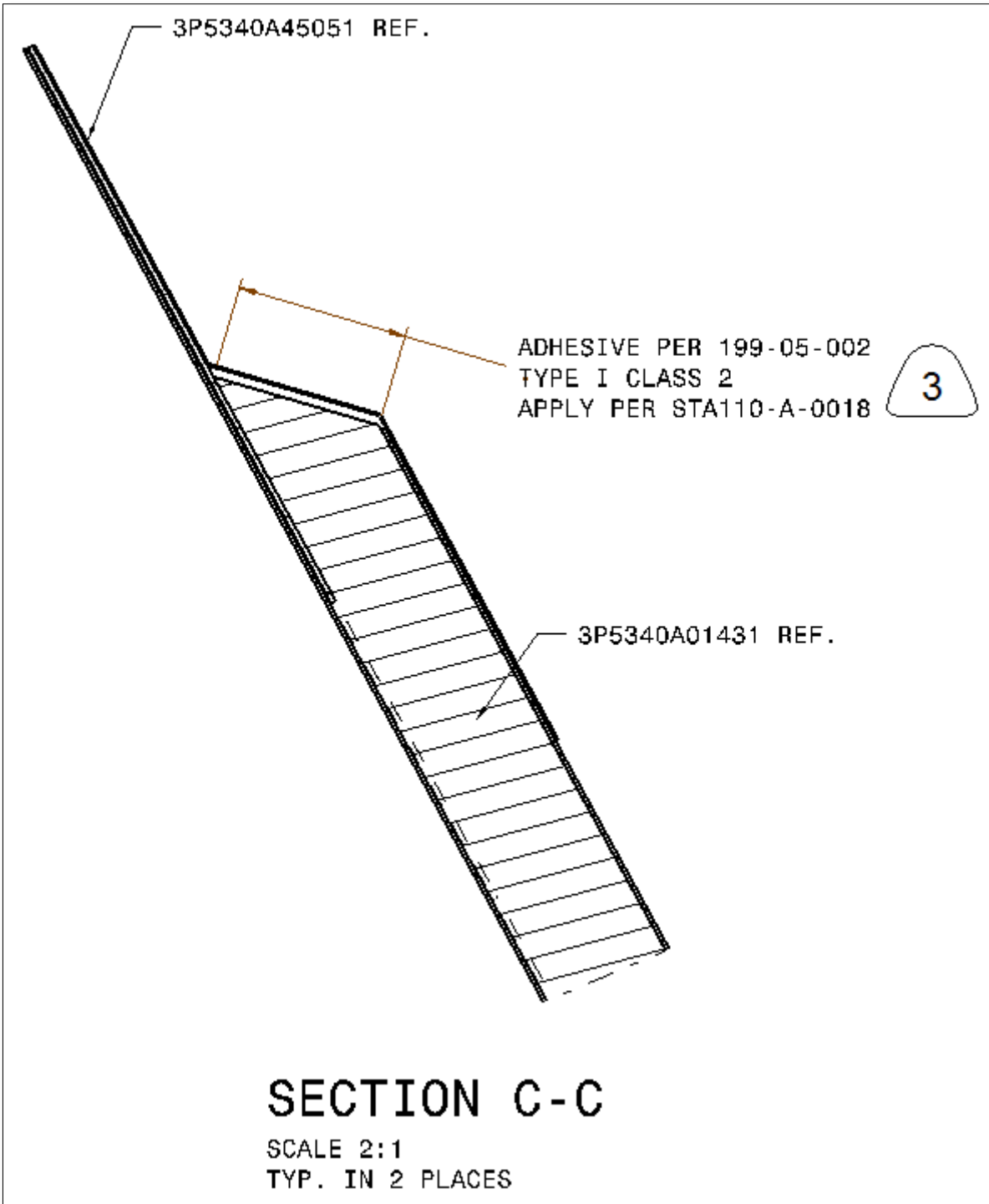

Figure 21 – Bonding Layer P/N: 3P5340A45051 Installation (Sheet 7 of 9)

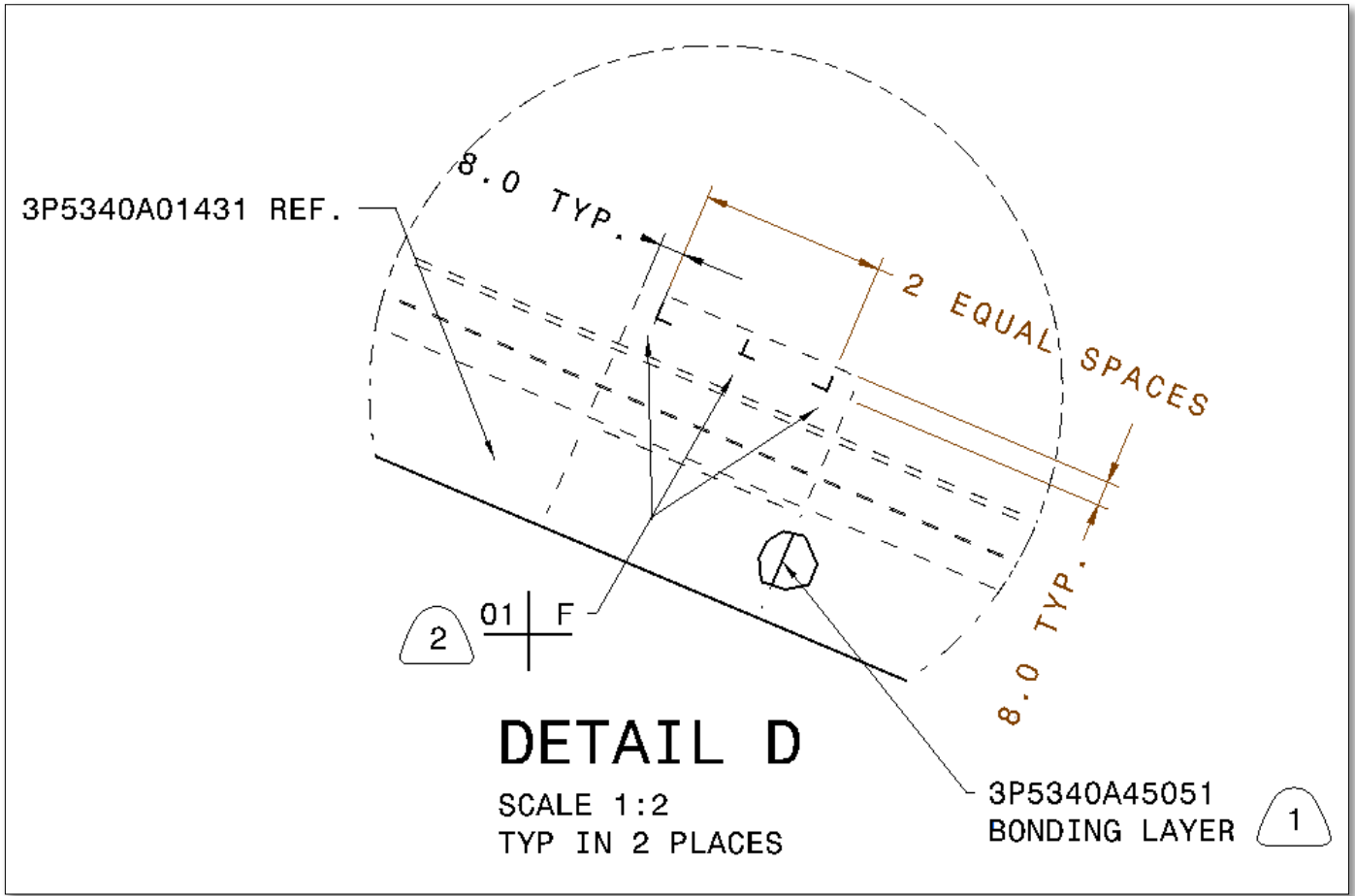

Figure 21 – Bonding Layer P/N: 3P5340A45051 Installation (Sheet 8 of 9)

NOTE / NOTES

- 1 D OMIT FIBERGLASS ON PANEL SURFACE IN CONTACT WITH BONDING LAYER AND PREPARE IT TO ASSURE GROUND CONTACT PER NTA663A.
- 2 D OMIT SEALANT ON RIVET.
- 3 D BOND BONDING LAYER ON PANEL APPLYING ADHESIVE ONLY ON SHOWN AREA.

Figure 21 – Bonding Layer P/N: 3P5340A45051 Installation (Sheet 9 of 9)

**ANNEX A**  
**ELECTRICAL BONDING CHECK**

**ELECTRICAL BONDING CHECK:**

Perform the electrical bonding check of the refurbished area of the rear fuselage structure in accordance with the following procedure:

**1. TEST EQUIPMENT:**

- 1.1. The test meter will be calibrated Bond Tester (Support Equip. 7) or equivalent.
- 1.2. The test meter shall have the following probes:
  - Duplex probes with rounded contacts points (0.8 mm minimum radius – recommended)
  - Single probes with rounded contact points (0.8 mm minimum radius) if the use of duplex probes is not possible due to accessibility issues.

**NOTE:** Sharp probes must not be used to avoid damages to the structure surface.

**NOTE:** During measurements, the structure under test shall be housed in a non-conductive fixture or laid down on non-conductive supports.

**2. CHECK PROCEDURE:**

- 2.1. The electrical bonding for the Forward Lower Panel Assembly (Spares Ref. 1) requires that low resistance paths be verified at a few key locations of the airframe.
  - Measurements between the designated test points.
  - Comparison between the measured resistance and the acceptable resistance limit.
  - If measured resistance exceed the limit of the Step 3 that follows, corrective actions shall be implemented and measurements shall be repeated.
  - Acceptable values shall be reported in the appropriate table that follows.

**3. ACCEPTABLE CRITERIA:**

- 3.1. Maximum resistance value allowed for the primary structure is 2.5 mΩ.

**4. UPPER DECK PANEL BONDING MEASUREMENT:**

For Forward Lower Panel Assembly (Spares Ref. 1) electrical resistance paths shall be measured between the following test points:

- 4.1. Between the Forward Lower Panel Assembly (Spares Ref. 1) bonding strip and the starter generator Ground Brackets (identified as GS3 and GS4 for short nose A/C and GS300 and GS301 for Long Nose A/C)
- 4.2. Between the Forward Lower Panel Assembly (Spares Ref. 1) bonding strip and the frame at STA 6701.5, P/N 3P5338A13551 and frame at STA 7200, P/N 3P5340A10251.



5. TEST RESULT SUMMARY:

5.1. The four electrical bonding measurements shall be reported in the following table:

TEST POINT	MEASUREMENT (mΩ)	OPERATOR	DATE
#1			
#2			
#3			
#4			