

Temporary Maintenance Instruction
TMI109-535 Rev. A

Main rotating scissors – Visual
examination (detailed)

A109E / A109S / AW109SP/SP-REGA /
A109LUH / A109LUHS / A109LUHNZ /
A109LUHAG / A109LUHAP / A109LUHN /
A109LOH / A119 / AW119MKII
Helicopters

The technical content of this document is approved under the authority of DOA nr. EASA.21J.005.

The present TMI will be evaluated for its introduction in the standard set of Technical Publication.

If no further notice is received, the present document expires on: January 12th, 2023.

2022-01-12

Introduction

The aim of this document is to give information about the new axial play limit (0,25mm) to be considered during examination of the ball bearing, parts of the M/R rotating scissor assy.

All the information reported in the subsequent pages will be updated in the next IETP revision:

DATA MODULE CODE	DATA MODULE TITLE	MODEL
0B-A-62-31-02-00A-310C-B	Rotating scissors – Visual examination (detailed)	A109S/AW109SP
09-A-62-31-10-00A-280A-B	Rotating scissors - Inspection	A109LUH Family
62-31-16	Rotating scissors - Inspection	A119/AW119MKII
62-31-16	Rotating scissors - Inspection	A109E

The content of this TMI will be introduced within next issue of pertinent technical publication at the earliest favorable occasion.

Revision A of this TMI is published in order to update the last step of the procedure.

Main rotating scissors – Visual examination (detailed)

Table of contents

[References](#)
[Preliminary requirements](#)
[Procedure](#)
[Requirements after job completion](#)

List of tables

1 [References](#)
 2 [Required conditions](#)
 3 [Support equipment](#)
 4 [Supplies](#)
 5 [Spares](#)

List of figures

1. *Rotating scissors – Detailed visual examination.*

References

Table 1 References

Section / Data Module	Title
0B-B-62-31-02-00A-530A-B ⁽¹⁾	Rotating scissors – Disassemble procedure
0B-B-62-31-02-00A-710A-B ⁽¹⁾	Rotating scissors – Assemble procedure

⁽¹⁾ Applicable to A109S/AW109SP Helicopters. For the other helicopter models refer to the applicable Section or Data Module of the Maintenance Manual.

Preliminary Requirements

Required conditions

Table 2 Required conditions

Condition	Data Module/Section /Technical Publication
The rotating scissors must be disassembled	0B-B-62-31-02-00A-530A-B

Support equipment

Table 3 Support equipment

Nomenclature	Identification No.	Qty
None		

Supplies

Table 4 Supplies

Nomenclature	Identification No.	Qty
Abrasive pad (Scotch bride)	Local supply	A.R.

Spares

Table 5 Spares

Nomenclature	Identification No.	Qty
None		

Safety conditions

None

Procedure

Note

(*) Applicable to A109S/AW109SP Helicopters. For the other helicopter models refer to the applicable Section or Data Module of the Maintenance Manual.

1. Examine the sleeves (1, Fig 1) and (2) as follows:
 - 1.1. Examine the outer surface of the sleeves for nicks and scores. If you find one or more nicks of more than 0.05 mm (0.0020 in) depth, you must replace the sleeve.
 - 1.2. Remove small scores with the Abrasive pad (Scotch bride) (Local supply). Keep a surface rough of 8 thru 12 RMS. If you cannot get a rough value of 8 thru 12 RMS, you must replace the sleeve.
2. Examine the Teflon lining of the bushings (7) on the top-rotating scissors (6) for condition and worn parts. If the Teflon lining is worn or has heavy erosion, you must send the top-rotating scissors to the Manufacturer or an authorized Repair Station for replacement.
3. Examine the bottom-rotating scissors (5) as follow:
 - 3.1. Examine the inner surface of the bushings (3) for fretting and scores. Remove small scores with the Abrasive pad (Scotch bride) (Local supply). If you find medium or heavy fretting or score, the bushings must be replaced, send the bottom-rotating scissors to the Manufacturer or an authorized Repair Station for replacement.
 - 3.2. Examine the bearing (4) for corrosion, free of movement, damage and for Teflon erosion. If you find one of these damages, the bearing must be replaced, send the bottom-rotating scissors to the Manufacturer or an authorized Repair Station for replacement.
 - 3.3. Do a check of the bearing plays. Make sure that the play is not more than 0.2 mm (0.0079 in) radial and 0.25 mm (0.00984 in) axial. **If the play is more than the permitted limits, you must send the bottom-rotating scissors (5) to the Manufacturer or an authorized Repair Station for replacement.**

Requirements after job completion

1. Assemble the rotating scissors. Refer to 0B-B-62-31-02-00A-710A-B (*).

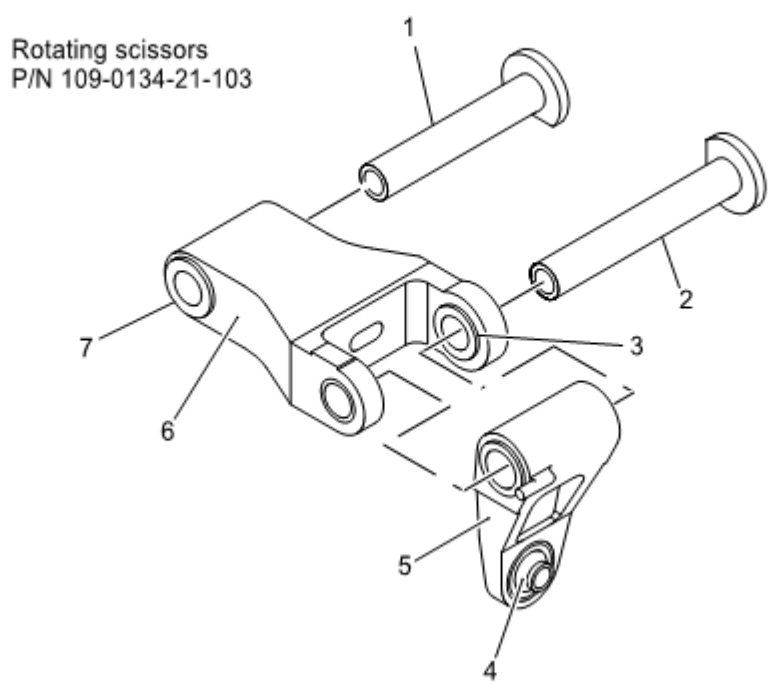
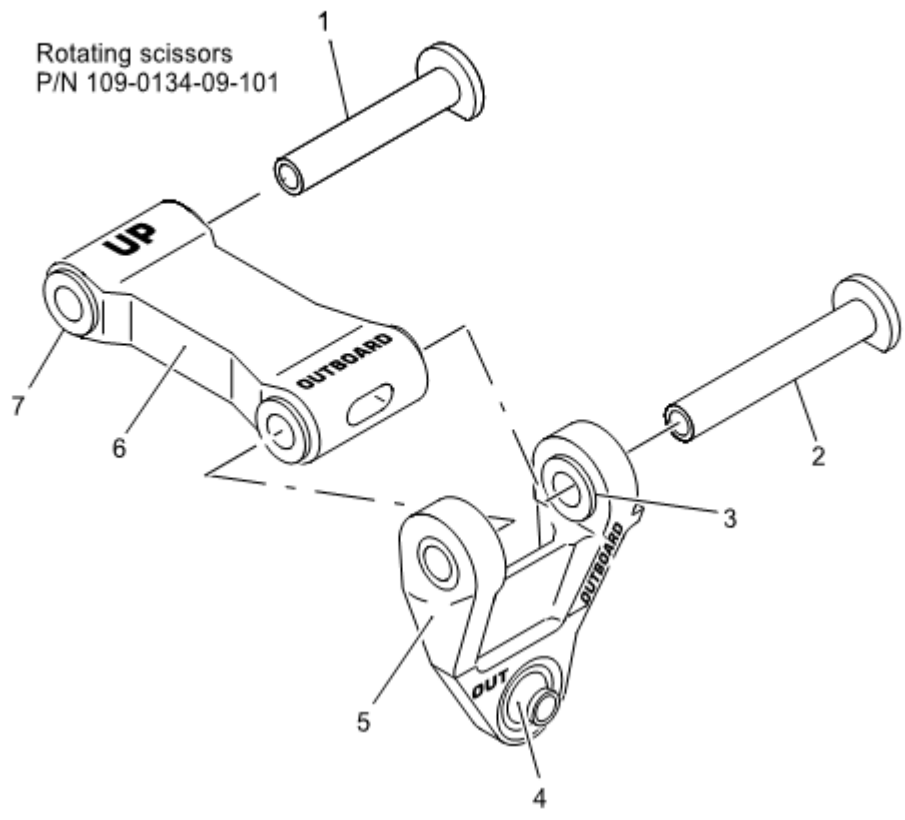

ICN-0B-A-623102-G-00001-03456-A-004-01

Figure 1 – Rotating scissors – Detailed visual examination.