

Temporary Maintenance Instruction
TMI109-503 Rev. B

Freewheel unit -
Function test

A109A/AII / A109C / A109BA /
A109K2 / A109K2 10001 / A109E /
A109S / AW109SP/SP-REGA /
A109LUH / A109LUHS / A109LUHNZ /
A109LUHAG / A109LUHAP / A109LUHN /
A109LOH / A119 / AW119MKII
Helicopters

The technical content of this document is approved under the authority of DOA nr. EASA.21J.005.

The present TMI will be evaluated for its introduction in the standard set of Technical Publication.

If no further notice is received, the present document expires on: January 21th, 2022.

2021-01-21

Introduction

The aim of this document is to give information about the function test of the Freewheel units P/N 109-0401-06 installed on the the main transmissions P/N 109-0400-02 and of the Freewheel units P/N 109-0401-26 installed on the the main transmissions P/N 109-0400-03.

This procedure will be endorsed within each applicable Component Repair & Overhaul Publication (OM / CR&OP) at the earliest favourable occasion and must be performed only by authorized personnel.

Rev B of this TMI is published in order to extend the expiration date.

Freewheel unit - Function test

Table of contents

[References](#)
[Preliminary requirements](#)
[Procedure](#)
[Requirements after job completion](#)

List of tables

1 [References](#)
 2 [Required conditions](#)
 3 [Support equipment](#)
 4 [Supplies](#)
 5 [Spares](#)

List of figures

1. [Freewheel units](#)

References

Table 1 References

Section / Data Module	Title
09-A-00-50-00-00A-013A-D	Material data information publication - Numeric index
OM - Section 63-21-01 ⁽¹⁾	Main transmission

⁽¹⁾ Applicable to A109E Helicopters. For the other helicopter models refer to the applicable Section or Data Module of the Overhaul Manual.

Preliminary requirements

Required conditions

Table 2 Required conditions

Condition	Data Module/Section /Technical Publication
None.	

Support equipment

Table 3 Support equipment

Nomenclature	Identification No.	Qty
1. Test rig	IS6-0236-01	1

Supplies

Table 4 Supplies

Nomenclature	Identification No.	Qty
1. (D) Oil	MIL-PRF-23699 (C272) ⁽²⁾	A.R.
2. (D) Oil	DOD-PRF-85734 (C008) ⁽²⁾	A.R.
3. (D) Corrosion preventive oil	Castrol Brayco 599	A.R.

⁽²⁾ Refer to 09-A-00-50-00-00A-013A-D of the Material Data Information Publication, if applicable.

Spares

Table 5 Spares

Nomenclature	Identification No.	Qty
None		

Safety conditions

WARNINGS

The consumable materials which have a "(D)" before their nomenclature are dangerous materials.

Before you use them, make sure you know the safety precautions and first aid instructions printed on:

- the label on the container material;
- the material safety sheet;
- the local safety regulations.

Make sure that the applicable first aid material is available.

Procedure

Note 1

The test must be done on the Test rig (Support equipment Ref. 1). Make sure that the tests agree with the speed, pressure and time lapse included in this procedure.

Note 2

As an alternative to the Test rig (Support equipment Ref. 1) you can use the main transmission as test bench. The operator must obey the speed, pressure and time lapse in this procedure.

Nota 3

⁽¹⁾ Applicable to A109E Helicopters. For the other helicopter models refer to the applicable Section or Data Module of the Overhaul Manual.

1. You must obey the precautions that follow during the test set-up:
 - The solvents for cleaning or degreasing must be used with the necessary caution to avoid damages to the seals and oil leakages.
 - Make sure that the seals are clean and the seal lip is not damaged.
 - Examine the shaft ends for correct chamfer and deburring.
 - Use the applicable tools for the seal installation.
 - Lubricate the shaft and the seal lip as necessary.
2. Install the two freewheel units on the main transmission (Fig 1). Refer to A119/A109 SERIES-OM (Section 63-21-01) (1).
3. Install the main transmission on the test rig and prepare it for the test. Refer to A119/A109 SERIES-OM (Section 63-21-01) (1).
4. Make sure that all the instruments of the test rig are calibrated correctly and obey the applicable rules.
5. Before you start the test, record the data that follow on an applicable form:
 - Date;
 - Test rig running time;
 - P/N and S/N of the freewheel units;
 - P/N and S/N of the main transmission;
 - Lubricating oil type;
 - Phase (Run-in, Leakage test, Preservation);
 - Test rig operator and/or test responsible;
 - Notes.

Note

At intervals of five minutes, record the test data that follow on the same form:

- Time;
- Ambient temperature;
- Torque and Speed (M/R mast);
- Loads at M/R mast;
- Speed (Engine 1 and 2);
- Torque (input 1 and 2);
- Torque (T/R mast);
- MGB oil temperature;
- MGB oil pressure.

6. Start the test rig, get gradually the speed indicated in Table 6 or Table 7 and make sure that the functionality of the installation and the recording instrumentation is correct.

Note

During the function test, make sure that you agree with the operating limits below:

- The lubricating oil pressure is between 40 and 50 psi;
- (Only for MGB P/N 109-400-03) The lubricating oil temperature is maximum 120°C;
- (Only for MGB P/N 109-400-02) The lubricating oil temperature is maximum 115°C.

7. Do the function test of the freewheel units as shown in Table 6 or Table 7. Record in the «NOTES» column of the test form any signs of malfunction with the significant running time as:

- a sudden increase of the oil temperature;
- a sudden pressure decrease;
- a noise and / or vibration level variation.

Note

If the test stops because of an event, the phase must be done again fully, after you find the causes and make a decision about the corrective actions.

Table 6. Run-in spectrum for freewheel units P/N 109-0401-06.

Phase	Duration	Main transmission input drive n° 1		Main transmission input drive n° 2		TGB Output (ref.)	Main drive shafts load (ref.)	
		Torque (kgm)	Speed (RPM)	Torque (kgm)	Speed (RPM)	Torque (kgm)	FWD (kg)	AFT (kg)
(n°)	(min)							
1	Note 1	10.7	6016	10.7	6016	3.5	400	900
Test bench shut down for general inspection								
2	15	24.0	6016	24.0	6016	10.5	400	900
3	15	48.3 (*)	6016	48.3 (*)	6016	10.5	400	900
4	5	57.2 (**)	5715	//	//	10.5	400	900
5	5	//	//	57.2 (**)	5715	10.5	400	900
(*) AEO torque made from 100% RPM MCP power (800 HP) for A109BA helicopters;								
(**) OEI torque made from 95% RPM MCP power (450 HP) for A109C and A109BA helicopters.								
<u>Test conditions:</u>								
Oil temperature (operating condition): 80°C ± 5°C (See Note 2)								
Oil pressure (operating condition): 40 – 50 psi								
Data recording interval: every 5 minutes maximum.								
Notes:								
1) Time necessary to check oil level and adjust oil pressure value;								
2) Only for the Phase 2, an oil temperature value not less than 65°C is permitted.								

Table 2. Run-in spectrum for freewheel units P/N 109-0401-26.

Phase	Duration	Main transmission input drive n° 1		Main transmission input drive n° 2		TGB Output (ref.)	Main drive shafts load (ref.)	
		Torque (kgm)	Speed (RPM)	Torque (kgm)	Speed (RPM)		FWD (kg)	AFT (kg)
1	Note 1	10.7	6000	10.7	6000	3.5	400	900
Test bench shut down for general inspection								
2	15	24.0	6000	24.0	6000	10.5	400	900
3	15	54.3 (*)	6000	54.3 (*)	6000	10.5	400	900
4	5	76.4 (**)	5700	//	//	10.5	400	900
5	2.5	93.0 (***)	5700	//	//	10.5	400	900
6	5	//	//	76.4 (**)	5700	10.5	400	900
7	2.5	//	//	93.0 (***)	5700	10.5	400	900
(*) AEO torque made from 100% RPM MCP power of 900 HP (ref. A109S helicopters); (**) OEI torque made from 95% RPM MCP power of 600 HP (ref. A109S helicopters); (***) OEI 2.5 minutes (730 HP) made from 95% RPM (ref. A109S helicopters).								
<u>Test conditions:</u> Oil temperature (operating condition): 80°C ± 5°C (See Note 2) Oil pressure (operating condition): 40 – 50 psi Data recording interval: every 5 minutes maximum.								
Notes: 1) Time necessary to check oil level and adjust oil pressure value; 2) Only for the Phase 2, an oil temperature value not less than 65°C is permitted.								

8. Visually examine the two freewheel units for general condition or leakage.
9. Remove the main transmission from the test bench.
10. Examine the chip detectors of the the main transmission. If metal particles are present, find their origin.
11. Remove the two freewheel units from the main transmission. Refer to A119/A109 SERIES-OM (Section 63-21-01) (1).
12. Examine the two freewheel units as written in the Inspection after Run-in procedure of the A119/A109 SERIES-OM (Section 63-21-01) (1).
13. If the inspection requires the replacement or the rework of a freewheel part, do the full function test

again.

14. If necessary, do the preservation to corrosion of the freewheel units as follows:
 - 14.1. Put the freewheel unit in a mixture of Oil (Supply Ref. 1) or Oil (Supply Ref. 2) and Corrosion preventive oil (Supply Ref. 3) at 5%.
 - 14.2. Pack the freewheel unit into an applicable bag to prevent dust and humidity contamination and to get a correct preservation.
 - 14.3. Record the date of the preservation and the expire date on an identification tag and attach it to the freewheel units.

Requirements after job completion

1. Install the two freewheel units on the main transmission. Refer to A119/A109 SERIES-OM (Section 63-21-01) (1).
2. Remove all the tools and the other items from the work area. Make sure that the work area is clean.

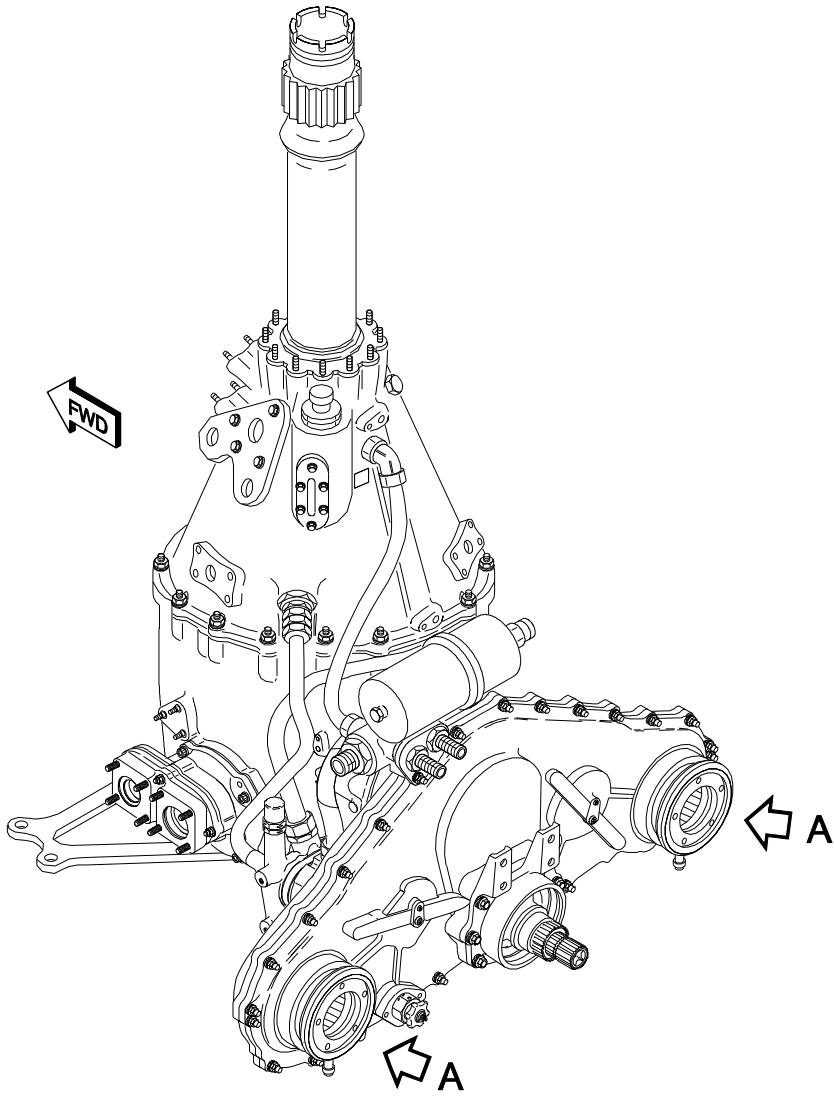

A

**FREEWHEEL UNIT
(P/N 109-0401-26)**

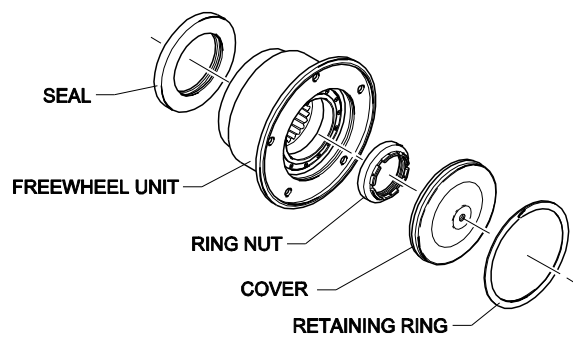

**FREEWHEEL UNIT
(P/N 109-0401-06)**

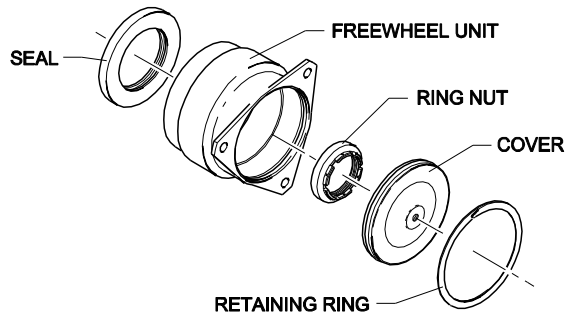

TMI109-503-001A

Figure 1 – Freewheel units.