



TECHNICAL INFORMATION LETTER

TIL N° T-189-24-003

DATE: July 26, 2024

REV.: /

To: Leonardo Helicopters products
Owners / Operators / Service Centres

**SUBJECT: Frame STA 5700, MLG Slant Beam Attachment
Inspection**

Helicopters Affected: All AW149/AW189 helicopters

Dear Customer,

Hereby, Leonardo Helicopters (LH) would like to inform you about the upcoming release of the Emergency Alert Service Bulletin (EASB) EASB189-397 to prescribe the inspection of the MLG Slant Beam Attachment, in the lower part of the STA 5700 Frame.

Following a recent review of Mandatory Inspection (MI) requirements for Main Cabin Assy, a dedicated inspection affecting the area highlighted in Annex A is required. This Inspection is applicable to those helicopters that have reached 14765 landings and needs to be repeated regularly after having reached this value.

For that reason, the following actions have been identified:

- **EASB189-397** that is going to be released will provide the instructions to perform the detailed inspection for cracks of the areas (3) shown in Figure 1 of Annex A. No special tool is required.
- A new Mandatory Inspection will be included in the relevant Aircraft Maintenance Planning Information (AMPI) at the first favourable occasion.

Frame STA 5700, MLG Slant Beam Attachment Inspection

Should you need any additional information, please do not hesitate to refer to your usual contact within the LH Engineering Support Team.

Yours Sincerely,



Marco D'Adamo
Leonardo Helicopters
Customer Support, Services & Training
Head of Product Support Engineering

Annex A

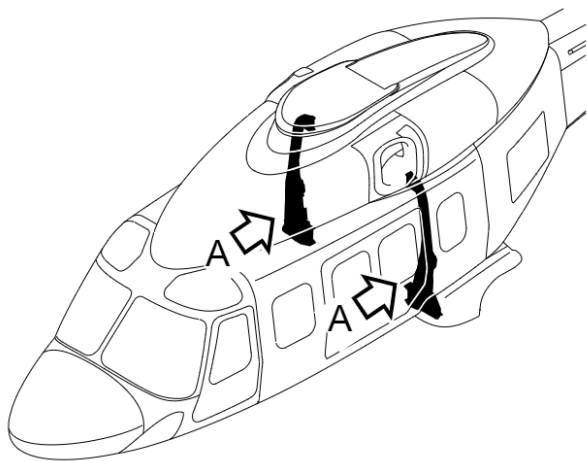

A
LEFT SIDE SHOWN
TYPICAL
FOR RIGHT SIDE

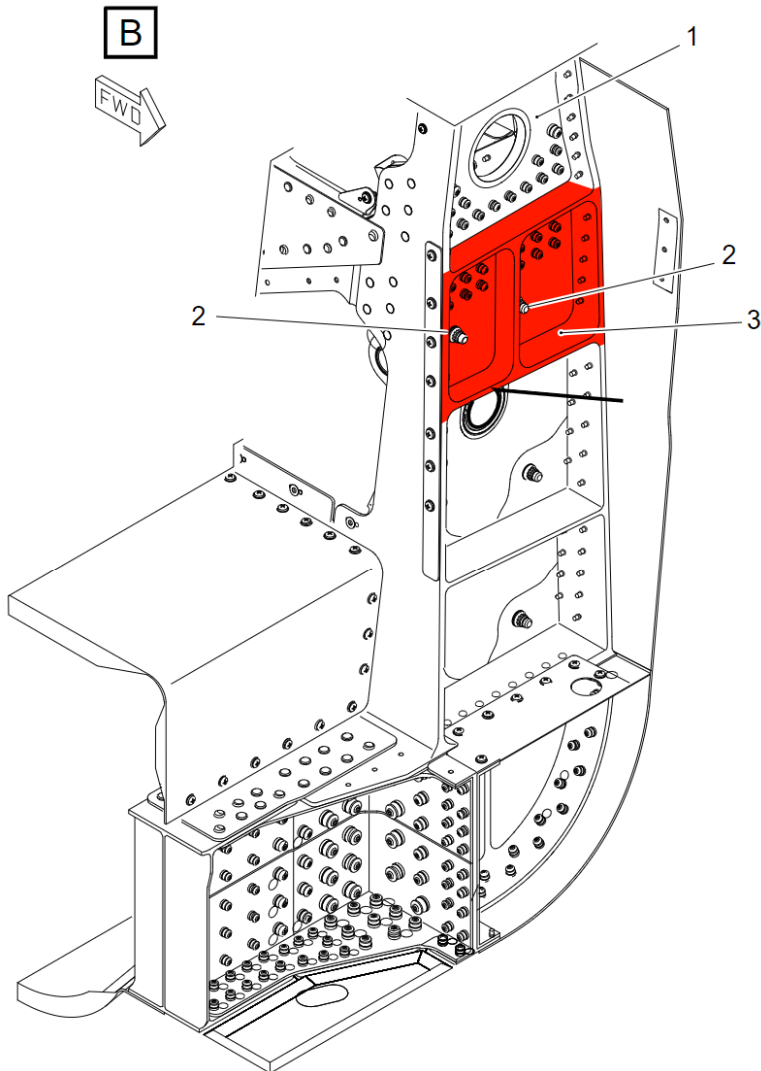
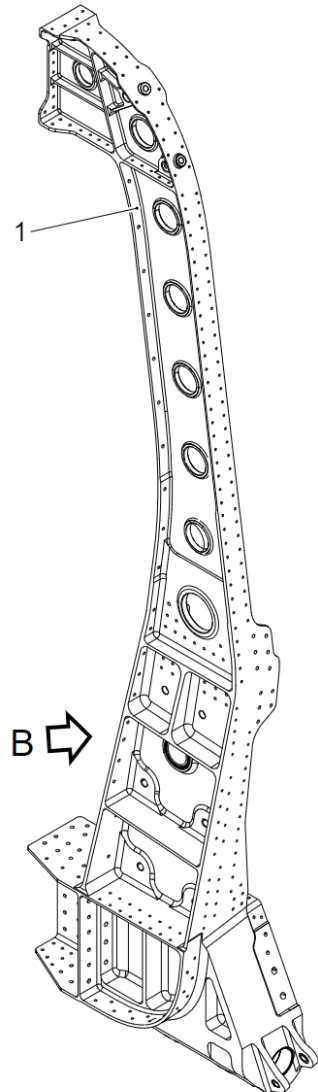

Forward section - Left/right frame at STA5700 - Detailed inspection