

TECHNICAL INFORMATION LETTER

TIL N° T-139-21-007

DATE: December 10, 2021

REV.: /

To: Leonardo Helicopters products
Owners / Operators / Service Centres

SUBJECT: AW139 – Modification of Engine breather air tube installation

Helicopters Affected: AW139 (Enhanced and Enhanced Plus configurations)

Dear Customer,

With the present letter Leonardo Helicopters (LH) would like to bring your attention to the recently updated AW139 Engine Breather Air Tube Installation hardware.

Following some reports of a possible loss of torque on the screws (Figure 1, item 7) which secure the Engine Breather Tube Fitting P/N 3G7100A01452 (Figure 1, item 6), LH would like to highlight that MS-standard screws P/N MS27039C1-09 are superseded by machine screws P/N NAS1802-3D10; the new screws have pre-drilled holes for the application of safety wire (Figure 2). In conjunction with safety wire, the retention of the installation torque is improved.

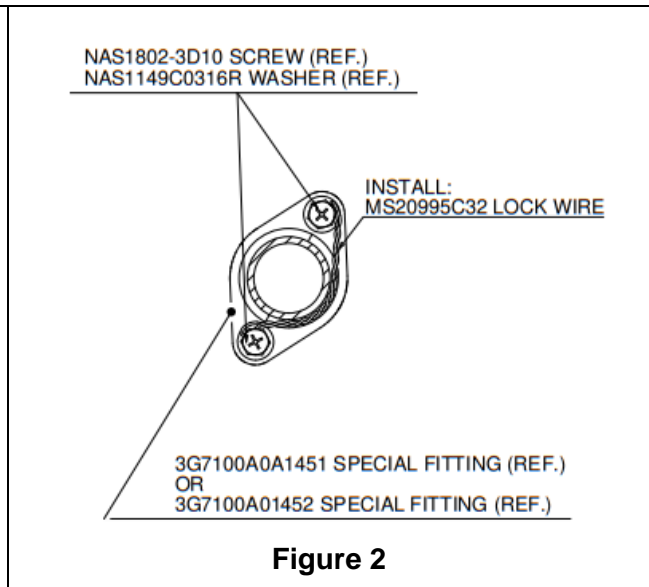
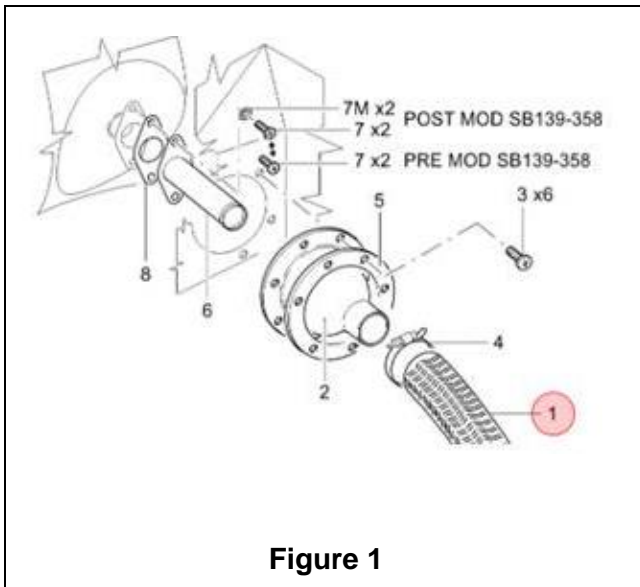

AW139 – Modification of Engine air breather tube installation

This modification is applicable to exhaust installations on Enhanced and Enhanced Plus series aircrafts that install the Forward Exhaust (P/N 3G7810A00332 (LH) or P/N 3G7806P08931 (LH) and 3G7810A00232 (RH) and P/N 3G7806P09031 (RH)) from the factory or via application of Service Bulletin SB139-358 Revision B.

EMBODIMENT

Production Helicopters

The new installation is part of basic design and production standard on delivered aircraft.

In-service Helicopters

This design modification has been implemented within:

- Revision B of SB139-358;
- IETP Issue 39:
 - IPD DM “39-A-71-71-00-030-941A-A Number 1 Engine Breather Air Tube - Illustrated Parts Data” and “39-A-71-71-00-040-941A-A Number 2 Engine Breather Air Tube - Illustrated Parts Data”;
 - AMP DM “39-A-71-71-21-00A-720A-A Special fitting (Number 1 and 2 engine bleed air tube) - Install procedure”.

Should you need any additional information, please do not hesitate to refer to the point of contact provided with the Customer Support & Training Worldwide Directory, available on Leonardo Customer Portal at this [link](#).

Yours Sincerely,

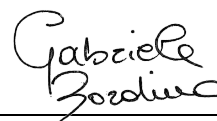

Gabriele Bordino
Head of Product Support Engineering