



SERVICE INFORMATION LETTER
SIL1022 March 20th, 2023 rev 01

Saft battery type A275CH1 P/N 415808
Nut vertically restraining the cells
P/N correction

1. Summary

This service information letter (SIL) is a notification from Saft concerning design improvement of the battery A275CH1 Saft (F6177) P/N 415808, regarding the nuts Saft (F6177) P/N 217201 vertically restraining the cells inside the battery box. Proposal is made to replace Saft (F6177) P/N217201 with P/N 102288 or equivalent. This service information letter replaces SIL0116.

2. Applicability

Owners / operators of the Saft battery type A275CH1, Saft (F6177) P/N 415808

Applicable upgrade:

- To new batteries produced by Saft,
- Only in the frame of battery maintenance (scheduled or unscheduled).

There is no obligation to perform this correction for batteries already in operation.

3. Description

NOTE: This improvement does not compromise the interchangeability of the assembly (interchangeability in both ways).

NOTE: Torque applied on the nuts still at 0.7 N.m \pm 0.07 N.m (6 lbf.in \pm 0.6 lbf.in).

NOTE: HFR self-locking nuts must be replaced after each disassembly.

NOTE: Washers below each nut are unchanged:

- 1 each plastic washer per nut, 4.3/18 PA6-6, Saft (F6177) P/N 416166. Quantity per battery: 6 each,
- 1 each metallic washer per nut, M4 A2, Saft (F6177) P/N 102021, according to standard ISO 7089-4-A2 or equivalent. Quantity per battery: 6 each.
- Order of assembly below the nut: first install the plastic washer then the metallic washer and finally install the nut.

Replacement of the nuts vertically restraining the cells (identified in green and by arrows below) must be done in the framework of a general overhaul as described in the OMM 24-30-99 chapter 5001 paragraph 8.

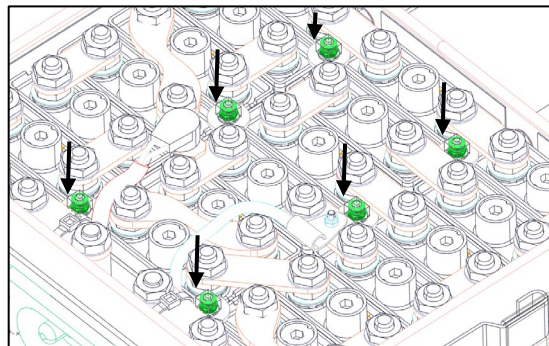
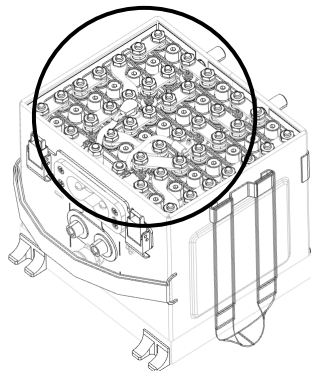



SERVICE INFORMATION LETTER
SIL1022 March 16th, 2023 rev 02

Previous nut definition before this SIL:

HFR self-locking Nut M4 A4-80 Saft (F6177) **P/N 217201**, according to NFE 25411 or equivalent.

Quantity per battery: 6 each.

New nut definition:

HFR Nut M4 A2-70 (Nylstop self-locking) Saft (F6177) **P/N 102288**,
according to DIN 985 or equivalent.

Quantity per battery: 6 each.

Copyright ©2023 Saft

This document and all information contained herein are the property of Saft. Its use is restricted solely to the maintenance of Saft batteries and may under no circumstances be used for any other manufacturer's products. No person may, in whole or in part, duplicate, use or disclose this information for any other purpose without the prior written consent of Saft.