

SERVICE BULLETIN No. 292 72 2222

Version: B

Date: 1 July 2022

**Reason for update:
Modification to the list of parts**

Modification

Recurring action

One-off action

**Applicable from:
"MAY 2021"**

**Subject:
Module M02 (Compressor) - Replacement of the equipped jet.
Modification TU 222.**

APPLICABLE ENGINE / VARIANT(S)	EFFECTIVITY CODE	MAINTENANCE LEVEL	CONDITION OF APPLICATION	OPERATIONAL EFFECT
ARRIEL 2 B, B1, B1A, C, C-PM, C1, C2, C2-CG, D, E, H, N, S1, S2	2-4	1, 2, 3	Application if leak found on the equipped jet 72-32-10-01-330 during a maintenance operation or upon customer request	Removal/Installation of the module M02 equipped jet
		4	Application upon first return to an approved Repair Center, for any cause of return	

This SB must be done in full compliance with manufacturer instructions. Refer to the Effectivity Code found in the table above.

SERVICE BULLETIN No. 292 72 2222

§1.GENERAL

§2.LEVEL 1, 2

§3.LEVEL 3

§4.LEVEL 4

§5.CERTIFICATES

1. GENERAL

1.1. Background

1.1.1. Context

Operators of ARRIEL 2 engines found oil leaks on the equipped jet of the compressor module (M02). Though equipped jets can be replaced on site, setting the adjusting washer includes special machining.

1.1.2. Analysis

The oil leak can be seen on the screwed-bonded plug of the equipped jet. Bonding this plug must be done delicately. Sealing tests administered during manufacturing do not ensure the absence of leaks when the engine is in full operation.

1.1.3. Solution

Modification TU 222:

- Replaces bonding with welding on the plug to make sure it stays sealed.
- Makes on site jet replacement more convenient by including the adjusted washer in the new parts list for the equipped jet.

1.2. Approval

- ARRIEL 2 B, B1, B1A, C, C1, C2, D, E, H, N, S1, S2 variants:
The technical content of this document is approved under the authority of the DOA (Design Organisation Approval) ref. EASA.21J.070.
- ARRIEL 2 C-PM, C2-CG variants:
The technical information given in this document is approved by Safran Helicopter Engines.

1.3. Summary of updates

Version	Date	Primary cause for update
A	02/03/2021	First issue
B	06/07/2022	Modification to the list of parts

End of Section §1

“General”

SERVICE BULLETIN No. 292 72 2222

§1.GENERAL

§2.LEVEL 1, 2

§3.LEVEL 3

§4.LEVEL 4

§5.CERTIFICATES

2. PROCEDURE DONE AT THE OPERATOR’S SITE OR AT A MAINTENANCE CENTER APPROVED FOR LEVEL 1, 2

Refer to the [compliance certificate in chapter 5.1](#)

2.1. Manpower

- Personnel: 1 mechanic.
- Necessary time: 1 man-hour (removal and installation of the equipped jet).

2.2. Tooling and/or materials

Mechanic's standard tooling.

2.3. Material information

2.3.1. Basic information

The parts list below, necessary for this SB, is for one engine.

2.3.2. List of parts

2.3.2.1. Parts necessary for this SB

New Part Number	Key	Qty	Description* / Item	Old Part Number	Key	Qty
ARRIEL 2 B, B1, B1A, C, C-PM, C1, C2, C2-CG, D, E, H, N, S1, S2						
7 292 15 825 A	A'	1	Equipped jet / 72-32-10-01-330	0 292 15 825 0	F	1
2 292 15 036 0 or 9 994 05 002 4	A A'	1	. Washer / 72-32-10-01-335			
			Washer / 72-32-10-01-340	9 994 05 002 4	F	1
0 292 15 051 0	A	1	Equipped jet / 72-32-10-01-330	0 292 15 825 0	C	1
2 292 15 036 0	A	1	. Washer / 72-32-10-01-335			
			Washer / 72-32-10-01-340	9 994 05 002 4	C	1
9 794 41 006 0	B	1	Seal / 72-32-10-01-360			

* Please tell us if you would like pricing information.

A full list of the old item part numbers above is given in the Spare Parts Catalog (SPC).

Key

A	Part included by this modification
A'	Part got after application of this modification as a retrofit
B	Part not included by this SB, but necessary for its completion
C	Part deleted by this modification
F	Part changed at the manufacturer's site or at a Safran Helicopter Engines-approved Repair Center

2.3.2.2. Parts necessary for the application of the maintenance tasks referred to in this SB

Refer to the applicable ARRIEL 2 Maintenance Manual or Spare Parts Catalog.

SERVICE BULLETIN No. 292 72 2222

§1.GENERAL

§2.LEVEL 1, 2

§3.LEVEL 3

§4.LEVEL 4

§5.CERTIFICATES

2.3.3. Supply conditions

Order supplies from:

Your local Safran Helicopter Engines Support Center

or

SAFRAN HELICOPTER ENGINES

Direction Support et Service

Département Commercial

40220 TARNOS – France

2.4. Necessary procedures

Replacement of the PRE TU 222 equipped jet with a POST TU 222 equipped jet: Refer to paragraph 2.6.

2.5. Block diagram for this SB

Not applicable.

2.6. Instructions on how to do the procedure**2.6.1. Implementation**

Removal of the engine is not necessary for this SB.

SERVICE BULLETIN No. 292 72 2222

§1.GENERAL

§2.LEVEL 1, 2

§3.LEVEL 3

§4.LEVEL 4

§5.CERTIFICATES

2.6.2. Operating instructions

2.6.2.1. Preliminary steps

- 2.6.2.1.1. Remove the oil supply pipe of the rear bearing: Refer to the applicable ARRIEL 2 Maintenance Manual, task 79-29-00-900-802.
- 2.6.2.1.2. Remove the oil supply pipe of the front bearing: Refer to the applicable ARRIEL 2 Maintenance Manual, task 79-29-00-900-805.
- 2.6.2.1.3. Remove the oil filter base assembly: Refer to applicable ARRIEL 2 Maintenance Manual, task 72-61-00-900-805.

2.6.2.2. Removal of the PRE TU 222 equipped jet (72-32-10-01-330) of the compressor casing (72-32-10-01-500)

- 2.6.2.2.1. Remove the screw (72-32-10-01-490) that attaches the equipped jet.
- 2.6.2.2.2. Remove and discard the equipped jet (72-32-10-01-330).
- 2.6.2.2.3. Remove and discard the adjusting washer (72-32-10-01-340).
- 2.6.2.2.4. Remove and discard the preformed packing (72-32-10-01-360) from the equipped jet.

2.6.2.3. Installation of the POST TU 222 equipped jet (72-32-10-01-330)

- 2.6.2.3.1. Lubricate a new preformed packing (72-32-10-01-360).
- 2.6.2.3.2. Install a new preformed packing (72-32-10-01-360) on the equipped jet (72-32-10-01-330).
- 2.6.2.3.3. Put the equipped jet (72-32-10-01-330) in position in its housing in the casing (72-32-10-01-500).
- 2.6.2.3.4. Put the washer between the casing (72-32-10-01-500) and the equipped jet (72-32-10-01-330).
- 2.6.2.3.5. Install the screw (72-32-10-01-490) through the equipped jet (72-32-10-01-330) and the washer (72-32-10-01-335).
- 2.6.2.3.6. Tighten the screw (72-32-10-01-490) that attaches the equipped jet (72-32-10-01-330) to the apparent torque of 4.8 N.m.

2.6.2.4. Additional operations

- 2.6.2.4.1. Install the oil filter base assembly: Refer to the applicable ARRIEL 2 Maintenance Manual, task 72-61-00-900-805.
- 2.6.2.4.2. Install the oil supply pipe of the front bearing: Refer to the applicable ARRIEL 2 Maintenance Manual, task 79-29-00-900-805.
- 2.6.2.4.3. Install the oil supply pipe of the rear bearing: Refer to the applicable ARRIEL 2 Maintenance Manual, task 79-29-00-900-802.

SERVICE BULLETIN No. 292 72 2222

§1.GENERAL

§2.LEVEL 1, 2

§3.LEVEL 3

§4.LEVEL 4

§5.CERTIFICATES

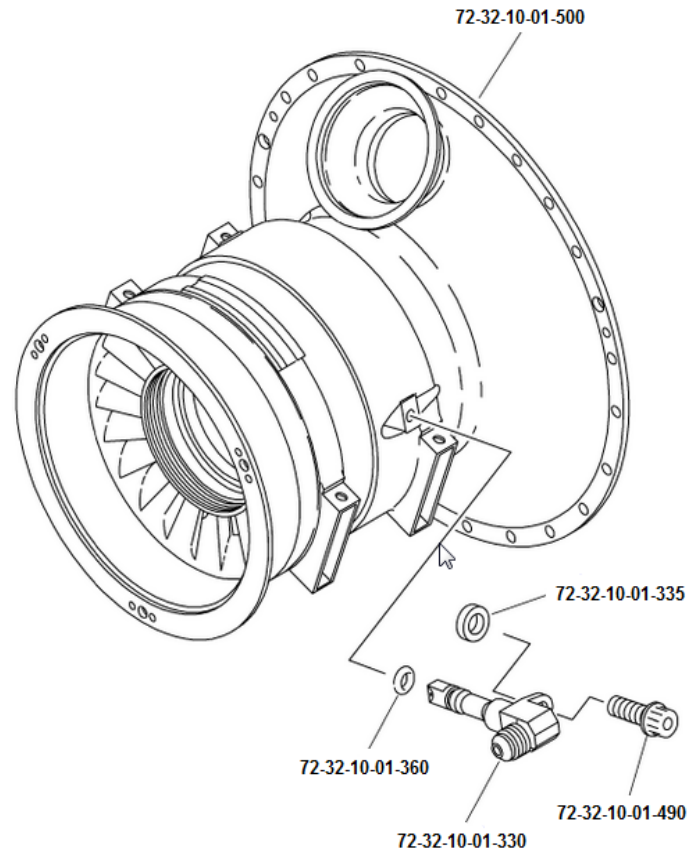

Equipped casing assembly
Figure 1

2.6.3. Reconditioning and checks

- Do a ground run check: Refer to the applicable ARRIEL 2 Maintenance Manual, task 71-02-13-280-801.
- Do an oil pressure check: Refer to the applicable ARRIEL 2 Maintenance Manual, task 79-00-00-200-801.

2.6.4. Identification

Refer to the Guides U441 and U015 for instructions on how to record the engine log book and the log cards.

2.6.4.1. Record the application of this SB on the log card of the module M02.

Note: If necessary, update the availability status.

2.6.4.2. Send back the fully-completed [compliance certificate in chapter 5.1](#) to tell Safran Helicopter Engines that this SB was done.

2.7. Weight and balance

Not applicable.

End of Section §2

“Procedure done at the operator’s site or at a Maintenance Center approved for Level 1, 2”

SERVICE BULLETIN No. 292 72 2222

§1.GENERAL

§2. LEVEL 1, 2

§3. LEVEL 3

§4. LEVEL 4

§5.CERTIFICATES

3. PROCEDURE DONE AT A MAINTENANCE CENTER APPROVED FOR LEVEL 3 OR AT THE OPERATOR'S SITE BY A MAINTENANCE CENTER APPROVED FOR LEVEL 3

Refer to the paragraphs that pertain to Maintenance Centers approved for level 1, 2 given in [§2](#).

End of section §3

“Procedure done AT a Maintenance Center approved for Level 3 OR AT THE OPERATOR'S SITE BY a Maintenance Center approved for Level 3”

SERVICE BULLETIN No. 292 72 2222

§1.GENERAL

§2. LEVEL 1, 2

§3. LEVEL 3

§4. LEVEL 4

§5.CERTIFICATES

4. PROCEDURE DONE AT A REPAIR CENTER APPROVED FOR LEVEL 4

 Refer to the [compliance certificate in chapter 5.2](#)
4.1. Manpower

- Personnel of approved Repair Center.
- Time calculated by the Repair Center as being applicable for this level of intervention.

4.2. Tooling and/or materials

Refer to the applicable ARRIEL 2 Overhaul Manual.

4.3. Material information
4.3.1. Basic information

The parts list below, necessary for this SB, is for one engine.

4.3.2. List of parts

New Part Number	Key	Qty	Description / Item	Old Part Number	Key	Qty
ARRIEL 2 B, B1, B1A, C, C-PM, C1, C2, C2-CG, D, E, H, N, S1, S2						
7 292 15 825 A	A'	1	Equipped jet / 72-32-10-01-330	0 292 15 825 0	F	1
2 292 15 036 0 or 9 994 05 002 4	A A'	1	. Washer / 72-32-10-01-335			
			Washer / 72-32-10-01-340	9 994 05 002 4	F	1
0 292 15 051 0	A	1	Equipped jet / 72-32-10-01-330	0 292 15 825 0	C	1
2 292 15 036 0	A	1	. Washer / 72-32-10-01-335			
			Washer / 72-32-10-01-340	9 994 05 002 4	C	1
9 794 41 006 0	B	1	Seal / 72-32-10-01-360			

Key

A	Part included by this modification
A'	Part got after application of this modification as a retrofit
B	Part not included by this SB, but necessary for its completion
C	Part deleted by this modification
F	Part changed at the manufacturer's site or at a Safran Helicopter Engines-approved Repair Center

4.3.3. Supply conditions

Order supplies from:

Your local Safran Helicopter Engines Support Center

or

SAFRAN HELICOPTER ENGINES

Direction Support et Service

Département Commercial

40220 TARNOS - France

SERVICE BULLETIN No. 292 72 2222

§1. GENERAL

§2. LEVEL 1, 2

§3. LEVEL 3

§4. LEVEL 4

§5. CERTIFICATES

4.4. Necessary procedures

Replacement of the PRE TU 222 equipped jet with a POST TU 222 equipped jet: Refer to paragraph 4.6.

4.5. Block diagram for this SB

Not applicable.

4.6. Instructions on how to do the procedure**4.6.1. Implementation**

Not applicable.

4.6.2. Operating instructions**4.6.2.1. Removal of the PRE TU 222 equipped jet**

4.6.2.1.1. Remove the screw (72-32-10-01-490).

4.6.2.1.2. Remove and discard the equipped jet (72-32-10-01-330).

4.6.2.1.3. Remove and discard the washer (72-32-10-01-340).

4.6.2.1.4. Remove and discard the preformed packing (72-32-10-01-360).

4.6.2.2. Installation of the POST TU 222 equipped jet

4.6.2.2.1. Lubricate a new preformed packing (72-32-10-01-360).

4.6.2.2.2. Install a preformed packing (72-32-10-01-360) on the equipped jet (72-32-10-01-330).

4.6.2.2.3. Install the equipped jet (72-32-10-01-330) on the compressor casing (72-32-10-01-500).

4.6.2.2.4. Put the washer (72-32-10-01-335) in position between the compressor casing (72-32-10-01-500) and the equipped jet (72-32-10-01-330).

4.6.2.2.5. Tighten the screw (72-32-10-01-490) to the standard torque: Refer to the Common Techniques Book, task 70-50-20-350-801.

SERVICE BULLETIN No. 292 72 2222

§1.GENERAL

§2. LEVEL 1, 2

§3. LEVEL 3

§4. LEVEL 4

§5.CERTIFICATES

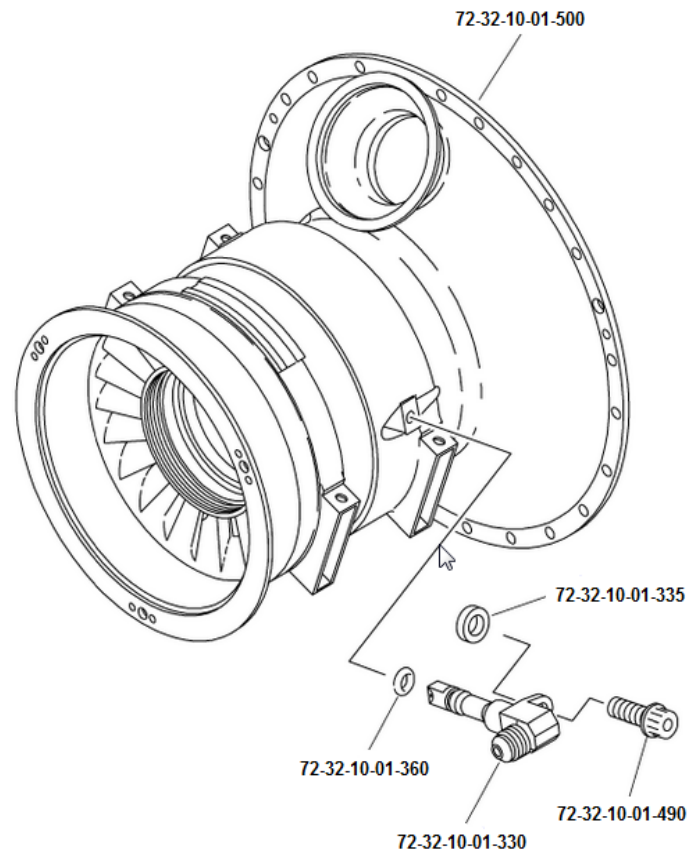

Equipped casing assembly

Figure 1
4.6.3. Reconditioning and checks

Refer to the applicable ARRIEL 2 Overhaul Manual.

4.6.4. Identification

Refer to the Guides U441 and U015 for instructions on how to record the engine log book and the log cards.

4.6.4.1. Record the application of this SB on the log card of the module M02.

Note: If necessary, update the availability status.

4.6.4.2. Send back the fully-completed [compliance certificate in chapter 5.2](#) to tell Safran Helicopter Engines that this SB was done.

4.7. Weight and balance

Not applicable.

End of Section §4

“Procedure done at a Repair Center approved for Level 4”

SERVICE BULLETIN No. 292 72 2222

§1. GENERAL

§2. LEVEL 1, 2

§3. LEVEL 3

§4. LEVEL 4

§5. CERTIFICATES

5.1- Compliance certificate of SB No. 292 72 2222 (TU 222) - LEVEL 1, 2, 3

Important:

After application of the instructions given in this SB, please mail or email the fully-completed compliance certificate to:

SAFRAN HELICOPTER ENGINES
Equipe Administration Base installée / Fleet Data Administrator Team, BP 25

40220 TARNOS - France

Email: data-fleet.fr.she@safrangroup.com

Equipment information						
Customer				Aircraft S/N		
	S/N	P/N	TSN*	TSO*	CSN*	CSO*
Engine						
Modified module M02						
Removed PRE TU 222 equipped jet						
Installed POST TU 222 equipped jet						

* TSN = Time Since New
 CSN = Cycles Since New

TSO = Time Since Overhaul
 CSO = Cycles Since Overhaul

Work done by:	
----------------------	--

I certify that the above-mentioned module has been modified according to the directives given in this SB.

Date [JJ/MMMM (letters)/AAAA]	Name	Job title

Signature:

SERVICE BULLETIN No. 292 72 2222

§1. GENERAL

§2. LEVEL 1, 2

§3. LEVEL 3

§4. LEVEL 4

§5. CERTIFICATES

5.2- Compliance certificate of SB No. 292 72 2222 (TU 222) - LEVEL 4

Important:

After application of the instructions given in this SB, please mail or email the fully-completed compliance certificate to:

SAFRAN HELICOPTER ENGINES
Equipe Administration Base installée / Fleet Data Administrator Team, BP 5

40220 TARNOS - France

Email: data-fleet.fr.she@safrangroup.com

Equipment information						
Customer				Aircraft S/N		
	S/N	P/N	TSN*	TSO*	CSN*	CSO*
Engine						
Modified module M02						

* TSN = Time Since New
 CSN = Cycles Since New

TSO = Time Since Overhaul
 CSO = Cycles Since Overhaul

Work done by:

I certify that the above-mentioned engine has been modified according to the directives given in this SB.

Date [JJ/MMMM (letters)/AAAA]	Name	Job title

Signature: