SERVICE BULLETIN

N° **139-675**

OPTIONAL

DATE: September 20, 2021

REV. : B - February 21, 2024

TITLE

ATA 97 - KIT CABIN CAMERA SOFT LINER INSTALLATION

REVISION LOG

Rev. A of this Service Bulletin is issued in order to extend the effectivity.

Furthermore, Rev. A includes new Fig. 12 in order to allow the rework of the upper cover door frame.

Rev.B of this Service Bulletin is issued in order add note before step 2.2.9. |

Revision bars identify changes.

1. PLANNING INFORMATION

A. EFFECTIVITY

AW139 helicopters S/N 31403, 31413, 31420, 31427, 31434, 31439, 31448, 31469, 31481, 31489, 31521, 31526, 31528, S/N 31767, 31794, 31797, 31802, 31813, 31819, 31839, 31847, 31853, 31861, 31868 and 31874.

B. COMPLIANCE

At Customer's option.

C. CONCURRENT REQUIREMENTS

N.A.

D. REASON

This Service Bulletin is issued in order to provide the necessary instruction on how to perform the installation of kit cabin camera soft liner P/N 4G9750F00611.

LH issued this SB for the following reason:

Helicopter Reliability/Maintainability	
Product Improvement	
Obsolescence	
Customization	✓
Product/Capability Enhancement	

E. DESCRIPTION

This Service Bulletin provides the necessary instruction to perform the Kit Cabin Camera Soft Liner P/N 4G9750F00611 installation.

The primary components of the kit are:

- The video camera;
- The video camera support;
- The video camera protection fairing;
- The power supply.

The video camera (DS203) is installed on the ceiling of the cabin between STA 3900 and STA 5700.

F. APPROVAL

The technical content of this Service Bulletin is approved under the authority of DOA nr. EASA.21.J.005. For helicopters registered under other Aviation Authorities, before applying the Service Bulletin, applicable Aviation Authority approval must be checked within Leonardo Helicopters customer portal.

EASA states mandatory compliance with inspections, modifications or technical directives and related time of compliance by means of relevant Airworthiness Directives.

If an aircraft listed in the effectivity embodies a modification or repair not LHD certified and affecting the content of this Service Bulletin, it is responsibility of the Owner/Operator to obtain a formal approval by Aviation Authority having jurisdiction on the aircraft, for any adaptation necessary before incorporation of the present Service Bulletin.

G. MANPOWER

To comply with this Service Bulletin, the following MMH are deemed necessary:

Part I: approximately thirty-five (35) MMH;

Part II: approximately fifteen (15) MMH.

MMH are based on hands-on time and can change with personnel and facilities available.

H. WEIGHT AND BALANCE

PART I

WEIGHT (kg)	ARM (mm)	MOMENT (kgmm)
		0.8
LONGITUDINAL BALANCE	4358	3486.4
LATERAL BALANCE	-717	-573.6

PART II

WEIGHT (kg)	ARM (mm)	MOMENT (kgmm)
		0.11
LONGITUDINAL BALANCE	5308	583.88
LATERAL BALANCE	-851	-93.61

I. REFERENCES

I.1 PUBLICATIONS

Following Data Modules refer to AMP:

<u>DATA MODULE</u>	<u>DESCRIPTION</u>	<u>PART</u>
DM01 39-A-00-20-00-00A-120A-A	Helicopter safety - Pre-operation (make helicopter safe for maintenance).	I, II
DM02 39-A-06-41-00-00A-010A-A	Access doors and panels – General data.	I, II
DM03 39-A-20-10-19-00A-920A-A	Plastic loom support – Replacement	I
DM04 39-A-20-10-09-00A-920A-A	Bonded studs - Replacement	I
DM05 39-A-20-00-00-00A-711A-A	Threaded fasteners – Tighten procedure	I, II
DM06 39-A-97-56-01-00A-720A-K	Video camera – Install procedure	II
DM07 39-A-97-56-05-00A-720A-K	Power supply - Install procedure	II
DM08 39-A-97-56-00-00A-320A-K	Cabin-video camera system – Operational check	II
DM09 39-A-11-00-01-00A-720A-A	Decal – Install procedure	II

I.2 ACRONYMS & ABBREVIATIONS

AMD	Aircraft Material Data Information
AMP	Aircraft Maintenance Publication
DM	Data Module
DOA	Design Organization Approval
EASA	European Aviation Safety Agency
LH	Leonardo Helicopters
MMH	Maintenance Man Hours
P/N	Part Number
S/N	Serial Number
TB	Terminal Board

I.3 ANNEX

N.A.

J. PUBLICATIONS AFFECTED

N.A.

K. SOFTWARE ACCOMPLISHMENT SUMMARY

N.A.

2. MATERIAL INFORMATION

A. REQUIRED MATERIALS

A.1 PARTS

PART I

#	P/N	ALTERNATIVE P/N	DESCRIPTION	Q.TY	LVL	NOTE	LOG P/N
1	4G9750F00611		KIT CABIN CAMERA SOFT LINER	REF	.		-
2	3G9750A01411		COMPLETE PROVISION	REF	..		-
3	3G5310A99311		STRUCTURAL PROVISION	REF	...		-
4	3G5317A00432		Support assy	1		139-675L1
5	3G5317A12931		Power supply support assy	1		139-675L1
6	MS27039-0805		Screw	4		139-675L1
7	NAS1149DN816K		Washer	4		139-675L1
8	NAS1835-08		Insert	4		139-675L1
9	MS20426AD3-7		Rivet	0.1 kg		139-675L1
10	MS20426AD4-7		Rivet	0.1 kg		139-675L1
11	3G9750A01311		ELECTRICAL PROVISION	REF	...		-
12	3G9B01A85101		Cabin camera C/A (B1A851)	1		139-675L1
13	3G9B02A73901	3G9B02A73901A1R	Cabin camera C/A (B2A739)	1		139-675L1
14	3G9B02A74101		Cabin camera C/A (B2A741)	1		139-675L1
15	AW002FT109		Grommet	1		139-675L1
16	A388A3E10C		Standoff	5		139-675L1
17	AW001CB02H		Clamp	4		139-675L1
18	AW001CB04H		Clamp	2		139-675L1
19	AW001CL001-N6		Support	1		139-675L1
20	AW001CL002C-X2		Support	1		139-675L1
21	AW001CL007-CM		Support	7		139-675L1
22	AW001CL509-N6		Support	3		139-675L1
23	NAS1149D0332J		Washer	4		139-675L1
24	NAS1190E3P6AK		Screw	4		139-675L1
25	NAS1720H4L4A		Rivet	3	..		139-675L1
26	3G9750A01912		RCS CAMERA INSTL	REF	..		-
27	3G9750A02331		Interface support assy	1	...		139-675L1
28	3G9750A02451		Adjustable support	1	...		139-675L1
29	3G9750A02531	3G9750A02531A2	RCS camera fairing	1	...		139-675L1
30	A428A08C08	A428A08C08T	Screw	4	...		139-675L1
31	MS27039-0809		Screw	1	...		139-675L1
32	MS20426AD3-7		Rivet	0.1 kg	...		139-675L1
33	NAS1149DN632J		Washer	3	...		139-675L1
34	NAS1802-3-7		Screw	2	...		139-675L1
35	3G2490LXXXXX		Integrally-lighted AUX C/B panel	1	.		-
36	MS3320-1		CB circuit breaker	1	.		139-675L1
37	A556A-T20		Wire	2.5 m	.		139-675L1
38	ED300CB436		Decal	1	.		139-675L1
39	MS27722-23		Switch	1	.		139-675L1
40	252-8554-000		Ferrule	2	.		139-675L1
41	MS25036-149		Terminal lug	1	.		139-675L1
42	M39029/1-102		Electrcial contact	2	.		139-675L1
43	M39029/56-351		Electrcial contact	1	.		139-675L1

PART II

#	P/N	ALTERNATIVE P/N	DESCRIPTION	Q.TY	LVL	NOTE	LOG P/N
44	4G9750F00611		KIT CABIN CAMERA SOFT LINER	REF	.		-
45	3G9750A01211		EQUIPMENT INSTALLATION	REF	..		-
46	A631A01B		Spacer	1	...		139-675L2
47	ED300DS203		Decal	1	...		139-675L2
48	ED300PS81		Decal	1	...		139-675L2
49	NAS1149DN632J		Washer	2	...		139-675L2
50	NAS1802-06-16		Screw	2	...		139-675L2
51	NAS1802-06-5		Screw	2	...		139-675L2
52	NAS1802-06-6		Screw	4	...		139-675L2
53	NAS620C6L		Washer	6	...		139-675L2
54	RPS-77E		Power supply	1	...		139-675L2
55	RSC-B313-08		Camera	1	...		139-675L2
56	SVL-2.7/1.8NF		Lens	1	...		139-675L2

Refer also to IPD for the spares materials required to comply with the AMP DMs referenced in the accomplishment instructions.

A.2 CONSUMABLES

The following consumable materials, or equivalent, are necessary to accomplish this Service Bulletin:

#	SPEC./LHD CODE NUMBER	DESCRIPTION	Q.TY	NOTE	PART
57	AW001CK03LC	Lacing cord	AR	(1)	I
58	EN6049-006-25-5	Self-wrap braid	AR	(1)	I
59	EN6049-006-32-5	Self-wrap braid	AR	(1)	I
60	199-05-002 Ty 2 Cl 2	Adhesive EA 934NA (C397)	AR	(1)	I
61	A236A01AB	Edging	AR	(1) (2)	I

Refer also to AMDI for the consumable materials required to comply with the AMP DM referenced in the accomplishment instructions.

A.3 LOGISTIC MATRIX

In order to apply this Service Bulletin, the following Logistic P/N can be ordered in accordance with the applicable notes:

LOGISTIC P/N	Q.TY (PER HELO)	NOTE	PART
139-675L1	1	-	Part I
3G2490LXXXXX	1	-	Part I
139-675L2	1	-	Part II

NOTE

- (1) Item to be procured as local supply.
- (2) Indicated P/N refer to a specific size. The last four digits can be different based on the actual required installation.

B. SPECIAL TOOLS

N.A.

C. INDUSTRY SUPPORT INFORMATION

Customization.

3. ACCOMPLISHMENT INSTRUCTIONS

GENERAL NOTES

- a) Place an identification tag on all components that are re-usable, including the attaching hardware that has been removed to gain access to the modification area and adequately protect them until their later re-use.
- b) Shape the cables in order to prevent interference with the structure and the other existing installations, using where necessary suitable lacing cords and plastic cable tiedown.
- c) Exercise extreme care during drilling operations to prevent instruments, cables and hoses damage.
- d) After drilling, remove all swarf and sharp edges. Apply on bare metal a light film of primer unless the hole is used for ground connection.
- e) During the installation of bonding braids or components requiring grounding, clean the surface structure in order to obtain a good ground contact.
- f) Let adhesive cure at room temperature for at least 24 hours unless otherwise specified.
- g) Exposed thread surface and nut must be protected using a layer of tectyl according to MIL-C-16173 grade I.
- h) All lengths are in mm.

PART I

1. In accordance with DM 39-A-00-20-00-00A-120A-A, prepare the helicopter on ground for a safe maintenance. Disconnect the battery, all electrical power sources and/or the external power supply.
2. In accordance with DM DM0139-A-06-41-00-00A-010A-A and with reference to Figures 1 thru 8, gain access to the area affected by the installation and perform complete provision P/N 3G9750A01411 as described in the following procedure:
 - 2.1 Perform Structural Provision P/N 3G5310A99311 as described in the following procedure:

- 2.1.1 With reference to Figure 1 View C, temporarily locate the power supply support assy P/N 3G5317A12931 on the upper forward panel assy P/N 3G5333A09731 and countermark n°4 hole positions in accordance with the dimensions shown.
- 2.1.2 With reference to Figure 1 View C and Section D-D, drill n°4 holes $\text{Ø}17.42\div 17.55$ thru the upper forward panel assy P/N 3G5333A09731 in the previously countermarked positions.
- 2.1.3 With reference to Figure 1 Section D-D, install n°4 inserts P/N NAS1835-08 on the structure by means of Adhesive (C397).
- 2.1.4 With reference to Figure 1 View C, install the power supply support assy P/N 3G5317A12931 on the upper forward panel assy P/N 3G5333A09731 by means of n°4 screws P/N MS27039-0805 and n°4 washers P/N NAS1149DN816K. In accordance with DM 39-A-20-00-00-00A-711A-A, tighten the four screws to the standard torque value.
- 2.1.5 With reference to Figure 1 View A and Figure 2, temporarily locate the support assy P/N 3G5317A00432 on the LH upper cover door frame assy P/N 3G5330A23951 and countermark n°2 hole positions in accordance with the dimensions shown.
- 2.1.6 With reference to Figure 2 Section E-E, drill n°2 rivet holes thru the LH upper cover door frame assy P/N 3G5330A23951 in the previously countermarked positions.
- 2.1.7 With reference to Figure 2 Section E-E, install the support assy P/N 3G5317A00432 on the LH upper cover door frame assy P/N 3G5330A23951 by means of n°2 rivets P/N MS20426AD4.
- 2.2 Perform electrical provision P/N 3G9750A01311 as described in the following procedure:
 - 2.2.1 With reference to Figure 6 and in accordance with the applicable steps of DM 39-A-20-10-19-00A-920A-A, install n°5 supports P/N AW001CL007-CM and n°1 support P/N AW001CL002C-X2.
 - 2.2.2 With reference to Figure 6, install n°3 supports P/N AW001CL509-N6 by means of n°3 rivets P/N NAS1720H4L4A.
 - 2.2.3 With reference to Figure 6 and in accordance with the applicable steps of DM39-A-20-10-09-00A-920A-A, install n°4 standoffs P/N A388A3E10C.

NOTE

Use the edging P/N A236A on edges which are liable to cause damage to cable assemblies or where abrasion may occur.

NOTE

Install the self-wrap braid P/N EN6049-006-25-5 and/or P/N EN6049-006-32-5 where protection against chafing and prevention of contact with structure may occur.

NOTE

When necessary, replace existing clamp with suitable clamp.

- 2.2.4 With reference to Figures 3 thru 6, lay down the following cable assemblies on the existing routes unless otherwise indicated on the figures:
- 3G9B01A85101 Cabin camera C/A (B1A851)
 - 3G9B02A73901 Cabin camera C/A (B2A739)
 - 3G9B02A74101 Cabin camera C/A (B2A741)
- 2.2.5 With reference to Figures 3 thru 6, secure the cable assemblies laid down at the previous step by means of existing hardware and lacing cords P/N AW001CK03LC.
- 2.2.6 With reference to Figure 6 View Looking Down Cabin Roof LH Side, install n°4 clamps P/N AW001CB02H on the C/A B2A741 and the C/A B1A851 by means of n°2 screws P/N NAS1190E3P6AK and n°2 washers P/N NAS1149D0332J.
- 2.2.7 With reference to Figure 6 View Looking Down Cabin Up LH Side, install n°2 clamps P/N AW001CB04H on the C/A B2A739 by means of n°2 screws P/N NAS1190E3P6AK and n°2 washers P/N NAS1149D0332J.
- 2.2.8 With reference to Figure 6 Detail C, apply self-wrap braid for 160 mm on the routes B2A1 and B1A1 as shown.

NOTE

With reference to Figure 11 wiring diagram, if pin “J” and “W” are already occupied by other installations, it is allowed to perform the electrical connection to TB209P1 using any pair of free pins.

2.2.9 With reference to Figure 6 and Figure 11 wiring diagram, perform the electrical connection of the C/A B1A851 to the TB209 and to the connector PL1P3.

2.2.10 With reference to Figure 6 and Figure 11 wiring diagram, perform the electrical connection of the C/A B2A741 to the connector A1-3P3.

NOTE

If PART II is intended to be embodied immediately after PART I, do not perform the steps from 2.2.11 to 2.2.13.

2.2.11 With reference to Figure 6 and Figure 3 Detail A and B, insert the connectors PS81P6, PS81P2, PS81P7 and DS203P1 into the protective plugs.

2.2.12 With reference to Figure 6 and Figure 3 Detail A, cover the connectors PS81P7 and PS81P2 with self-wrap braid EN6049-006-25-5. Fix the self-wrap braid to the connector cabling by means of the lacing cord P/N AW001CK03LC.

2.2.13 With reference to Figure 6 and Figure 3 Detail B, cover the connectors PS81P6 and DS203P1 with self-wrap braid EN6049-006-32-5. Fix the self-wrap braid to the connector cabling by means of the lacing cord P/N AW001CK03LC.

3. In accordance with DM DM0139-A-06-41-00-00A-010A-A and with reference to Figures 7 and 8, gain access to the area affected by the installation and perform RCS camera instl P/N 3G9750A01912 as described in the following procedure:

3.1 With reference to Figure 7 View A and Figure 8 Detail B1, install the adjustable support P/N 3G9750A02451 on the interface support assy P/N 3G9750A02331 by means of n°2 screws P/N NAS1802-3-7 and n°2 washers NAS1149DN632J. In accordance with DM 39-A-20-00-00-00A-711A-A, tighten the two screws to the standard torque value.

3.2 With reference to Figure 8 Detail B3, View D and Section C-C, put the interface support assy P/N 3G9750A02331 in its correct installation position on the LH upper door frame assy P/N 3G5330A24631 and fixed it on the frame by means of n°4 rivets P/N MS20426AD3.

NOTE

If PART II is intended to be embodied immediately after PART I, do not perform the following step from 3.3 to 3.6.

- 3.3 With reference to Figure 7 View A and Figure 8 Detail B2, remove the 3 existing anchor nuts from the LH upper door frame assy P/N 3G5330A24631.
- 3.4 With reference to Figure 7 detail B, remove the existing 3 screws P/N A428A08C06 from the LH upper door frame assy P/N 3G5330A24631.

NOTE

If it is supplied Productive P/N 3G9750A02531A2 instead of P/N 3G9750A02531, it is necessary to rework P/N 3G5330A26151 in accordance with Fig. 12 and install it with the P/N 3G9750A02531A2.

- 3.5 With reference to Figure 7 View A, remove the LH upper cover door frame assy P/N 3G5330A26151 and its relevant hardware. Retain the hardware for later reuse.
 - 3.6 With reference to Figure 7 and Figure 8 Detail B1, install the camera protection fairing assy P/N 3G9750A02531 on the LH upper door frame assy P/N 3G5330A24631 and on the interface support assy P/N 3G9750A02331 by means of existing n°3 screws, n°3 screws P/N A428A08C08, n°1 screw P/N MS27039-0809 and n°1 washer P/N NAS1149DN632J. In accordance with DM 39-A-20-00-00-00A-711A-A, tighten the n°7 screws to the standard torque value.
4. Modify the auxiliary CB panel on the overhead panel, as described in the following procedure:

NOTE

Customer must contact Leonardo Helicopters PSE (engineering.support.lhd@leonardo.com) at least 3 months in advance of embodiment date of this Service Bulletin in order to collect the exact W/D applicable to helicopter configuration.

- 4.1 In accordance with AMP DM 39-A-24-91-04-00A-920A-K, remove the existing integrally-lighted panel from the Overhead AUX CB panel and install the new integrally-lighted panel P/N 3G2490LXXXXX.
- 4.2 Install circuit breaker P/N MS3320-1 CB436 in the indicated position on the new integrally-lighted panel 3G2490LXXXXX; apply the decal P/N ED300CB436 in an adjacent area.

- 4.3 Perform the electrical connection between pin 2 of CB436 and pin 2 of switch S299 by means of A556A-T20 wire. Use terminal lug P/N MS25036-149 for pin 2 of CB436 and electrical contact P/N M39029/1-102 with ferrule P/N 252-8554-000 for pin 2 of S299.
- 4.4 Perform the electrical connection between pin 3 of switch S299 and pin A of connector PL1J3 by means of A556A-T20 wire. Use electrical contact P/N M39029/1-102 with ferrule P/N 252-8554-000 for pin 3 of S299 and electrical contact P/N M39029/56-351 for pin A of PL1J3.
- 4.5 Perform a pin-to-pin continuity check of all the electrical connections made.
5. Return the helicopter to flight configuration and record for compliance with Part I of this Service Bulletin on the helicopter logbook.
6. Gain access to My Communications section on Leonardo WebPortal and compile the "Service Bulletin Application Communication".

As an alternative, send the attached compliance form to the following mail box:

engineering.support.lhd@leonardo.com

and (for North, Central and South America) also to:

AWPC.Engineering.Support@leonardocompany.us

PART II

1. In accordance with DM 39-A-00-20-00-00A-120A-A, prepare the helicopter on ground for a safe maintenance. Disconnect the battery, all electrical power sources and/or the external power supply.
2. In accordance with DM 39-A-06-41-00-00A-010A-A and with reference to Figures 9 and 10, gain access to the area affected by the installation and perform the equipment installation P/N 3G9750A01211 as described in the following procedure:
 - 2.1 With reference to Figure 9 View A and Figure 10 View B, install the spacer P/N A631A01B on the C/A B1A851.
 - 2.2 With reference to Figure 9 View A and Figure 10 View B and in accordance with DM 39-A-97-56-05-00A-720A-K, install the power supply P/N RPS-77E on the power supply support assy P/N 3G5317A12931.

NOTE

Perform the following step only if camera protection fairing assy P/N 3G9750A02531 is already installed on the frame.

- 2.3 With reference to Figure 7 Detail B, remove and retain the camera protection fairing assy P/N 3G9750A02531 from the LH upper door frame assy and from the interface support assy P/N 3G9750A02331 and its relevant hardware.

NOTE

Perform the following steps from 2.4 to 2.6 only if camera protection fairing assy P/N 3G9750A02531 is not already installed on the frame.

- 2.4 With reference to Figure 7 View A and Figure 8 Detail B2, remove the 3 existing anchor nuts from the LH upper door frame assy P/N 3G5330A24631.
- 2.5 With reference to Figure 7 detail B, remove the existing 3 screws P/N A428A08C06 from the LH upper door frame assy P/N 3G5330A24631.

NOTE

If it is supplied Productive P/N 3G9750A02531A2 instead of P/N 3G9750A02531, it is necessary to rework P/N 3G5330A26151 in accordance with Fig. 12 and install it with the P/N 3G9750A02531A2.

- 2.6 With reference to Figure 7 View A, remove the LH upper cover door frame assy P/N 3G5330A26151 and its relevant hardware. Retain the hardware for later reuse.

- 2.7 With reference to Figure 10 Detail C and Detail D and in accordance with DM 39-A-97-56-01-00A-720A-K, install the video camera P/N RSC-B313-08 on the support assy P/N 3G5317A00432 and the lens P/N SVL-2.7/1.8NF on the structure.
- 2.8 With reference to Figure 7 and Figure 8 Detail B1, install the camera protection fairing assy P/N 3G9750A02531 on the LH upper door frame assy and on the interface support assy P/N 3G9750A02331 by means of existing n°3 screws, n°3 screws P/NA428A08C08, n°1 screw P/N MS27039-0809 and n°1 washer P/N NAS1149DN632J. In accordance with DM39-A-20-00-00-00A-711A-A, tighten the n°7 screws to the standard torque value.
- 2.9 In accordance with DM 39-A-11-00-01-00A-720A-A and with reference to Figure 10 View B, install the decal P/N ED300PS81 on the power supply P/N RPS-77E.
- 2.10 In accordance with DM 39-A-11-00-01-00A-720A-A and with reference to Figure 10 Detail C, install the decal P/N ED300DS203 on the video camera P/N RSC-B313-08.
- 2.11 In accordance with DM 39-A-97-56-00-00A-320A-K, perform the operational check of the cabin-video camera system.
3. In accordance with weight and balance changes, update the Chart A (see Rotorcraft Flight Manual, Part II, section 6).
4. Return the helicopter to flight configuration and record for compliance with Part II of this Service Bulletin on the helicopter logbook.
5. Gain access to My Communications section on Leonardo WebPortal and compile the "Service Bulletin Application Communication".

As an alternative, send the attached compliance form to the following mail box:

engineering.support.lhd@leonardo.com

and (for North, Central and South America) also to:

AWPC.Engineering.Support@leonardocompany.us

CABIN CAMERA STRUCTURAL PROVISION
3G5310A99311

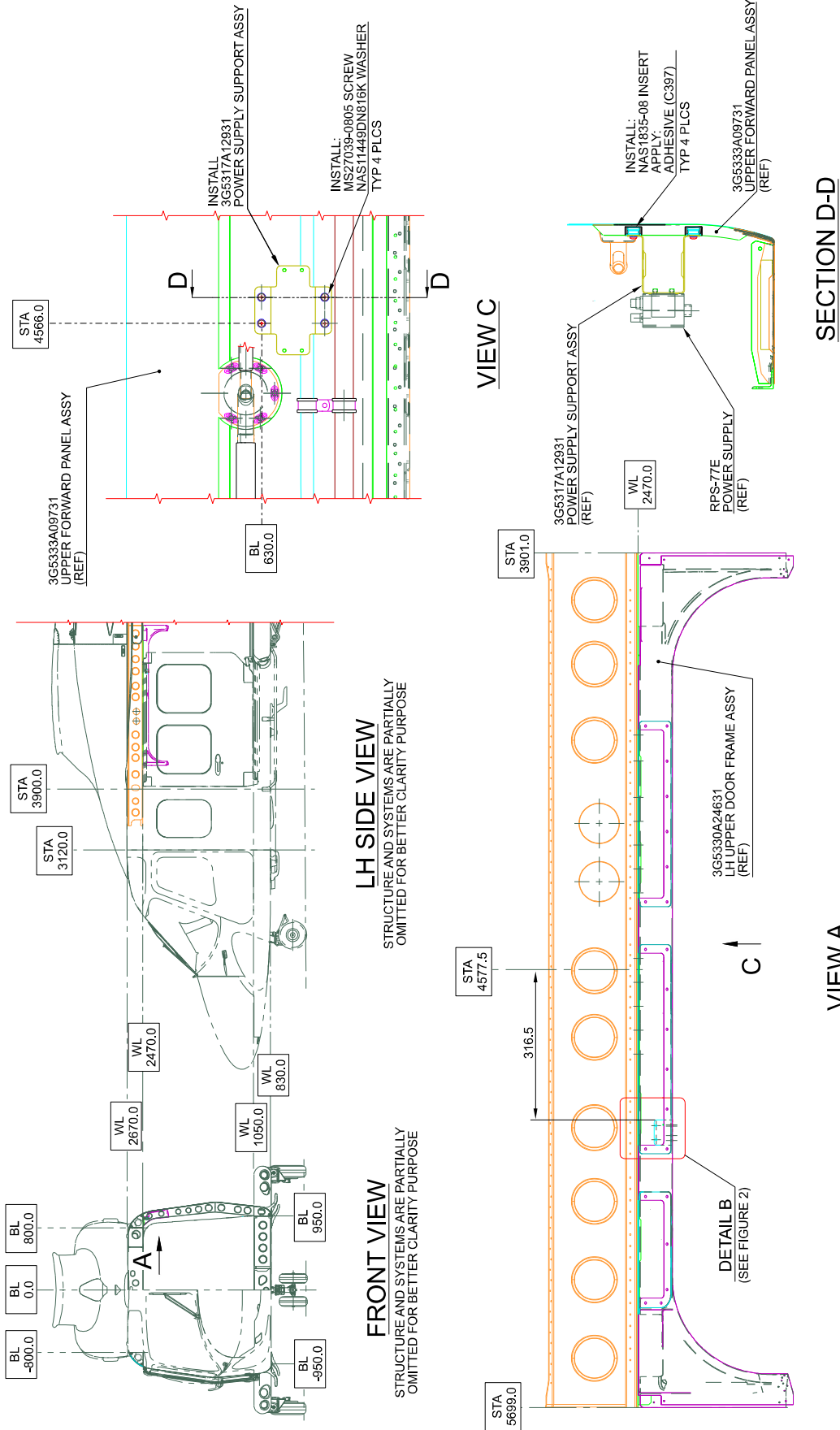

Figure 1

S.B. N°139-675 OPTIONAL
DATE: September 20, 2021
REVISION: B - February 21, 2024

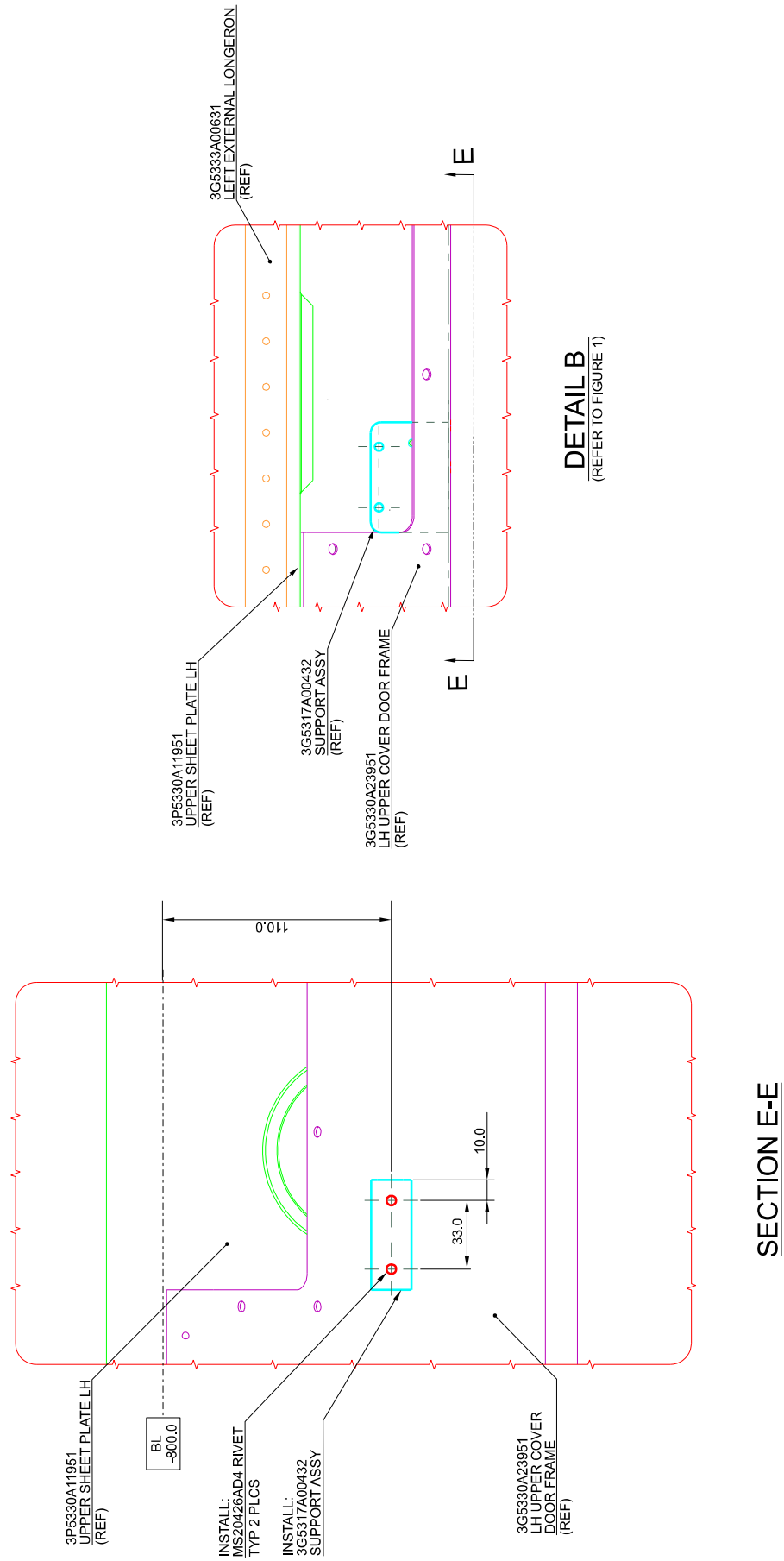
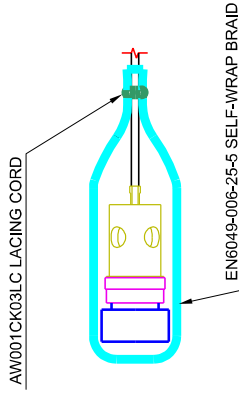
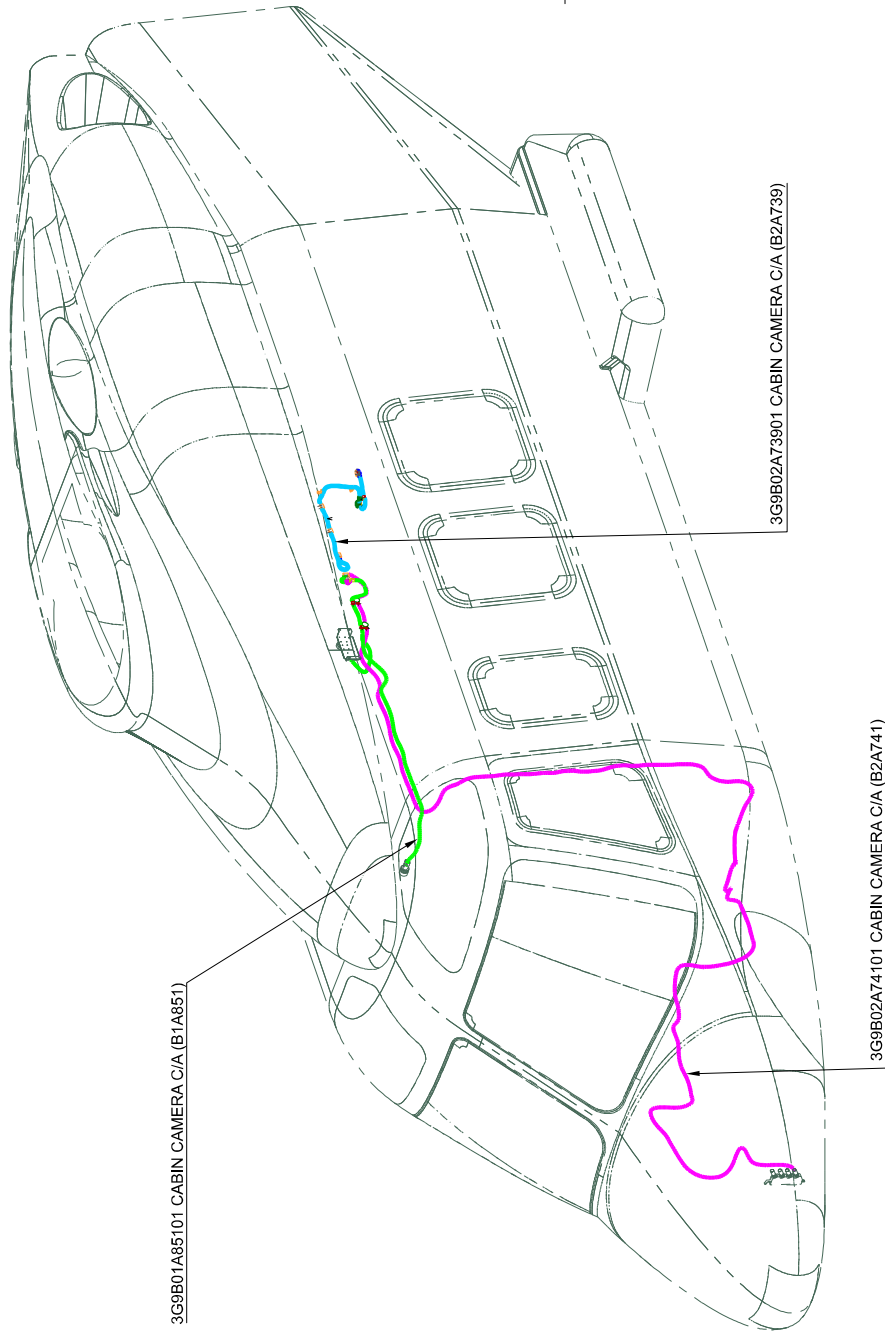
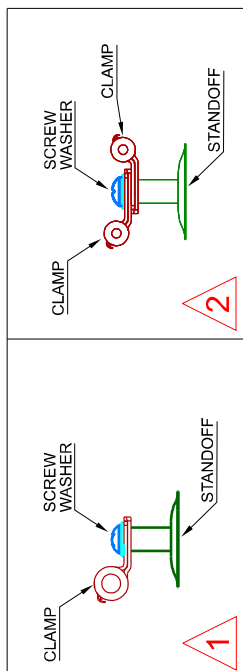
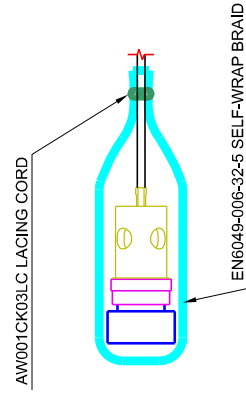

Figure 2

CABIN CAMERA ELECTRICAL PROVISION
3G9750A01311



DETAIL A
(REFER TO FIGURE 6,10)



DETAIL B
(REFER TO FIGURE 6,10)

Figure 3

S.B. N°139-675 OPTIONAL
DATE: September 20, 2021
REVISION: B - February 21, 2024

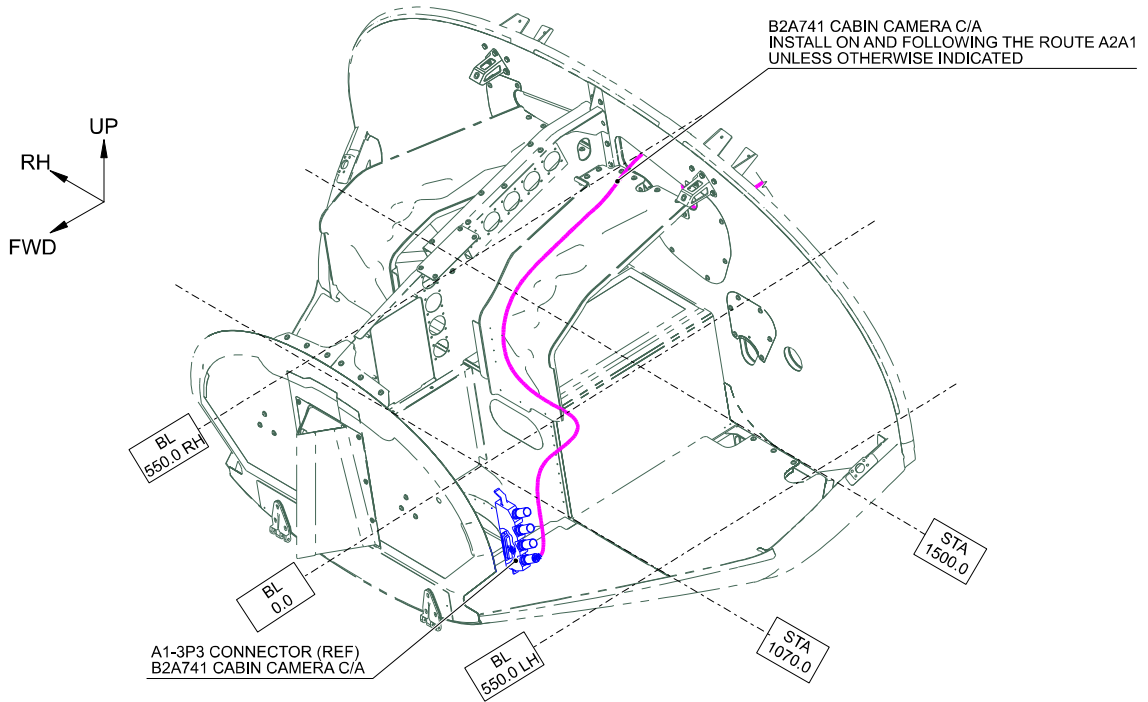

VIEW LOOKING NOSE LH SIDE

STRUCTURE AND SYSTEMS ARE PARTIALLY OMITTED FOR BETTER CLARITY PURPOSE

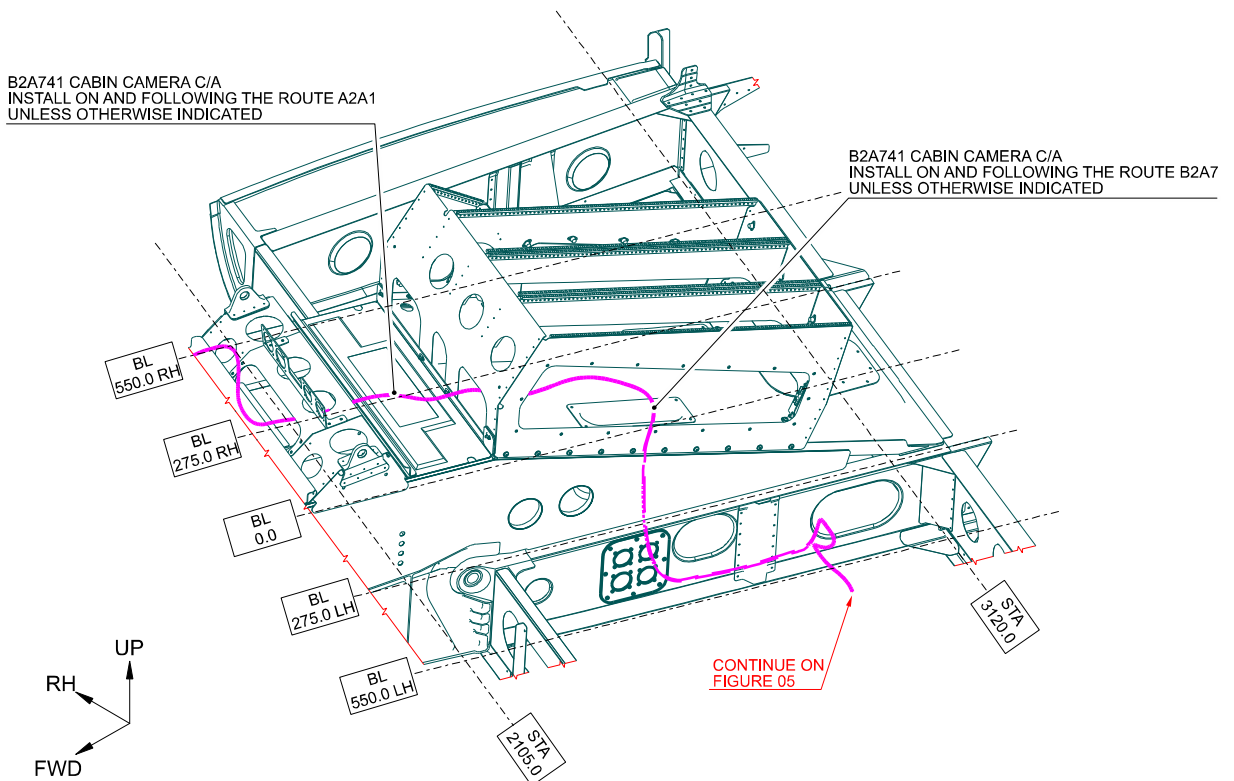

VIEW LOOKING INTERSEAT CONSOLE AREA

STRUCTURE AND SYSTEMS ARE PARTIALLY OMITTED FOR BETTER CLARITY PURPOSE

Figure 4

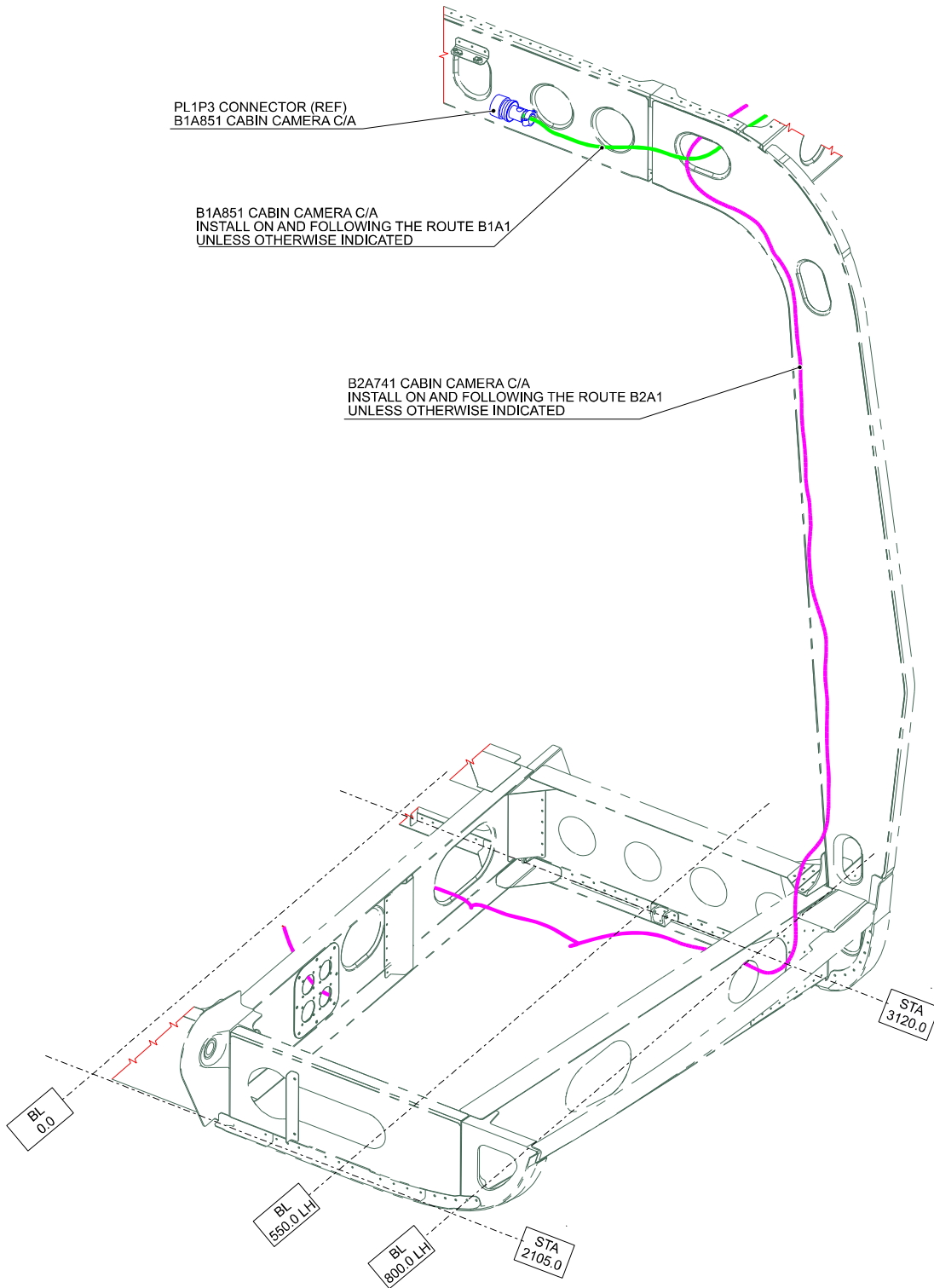

VIEW LOOKING FROM STA 2015 TO 3120
STRUCTURE AND SYSTEMS ARE PARTIALLY OMITTED FOR BETTER CLARITY PURPOSE

Figure 5

S.B. N°139-675 OPTIONAL
DATE: September 20, 2021
REVISION: B - February 21, 2024

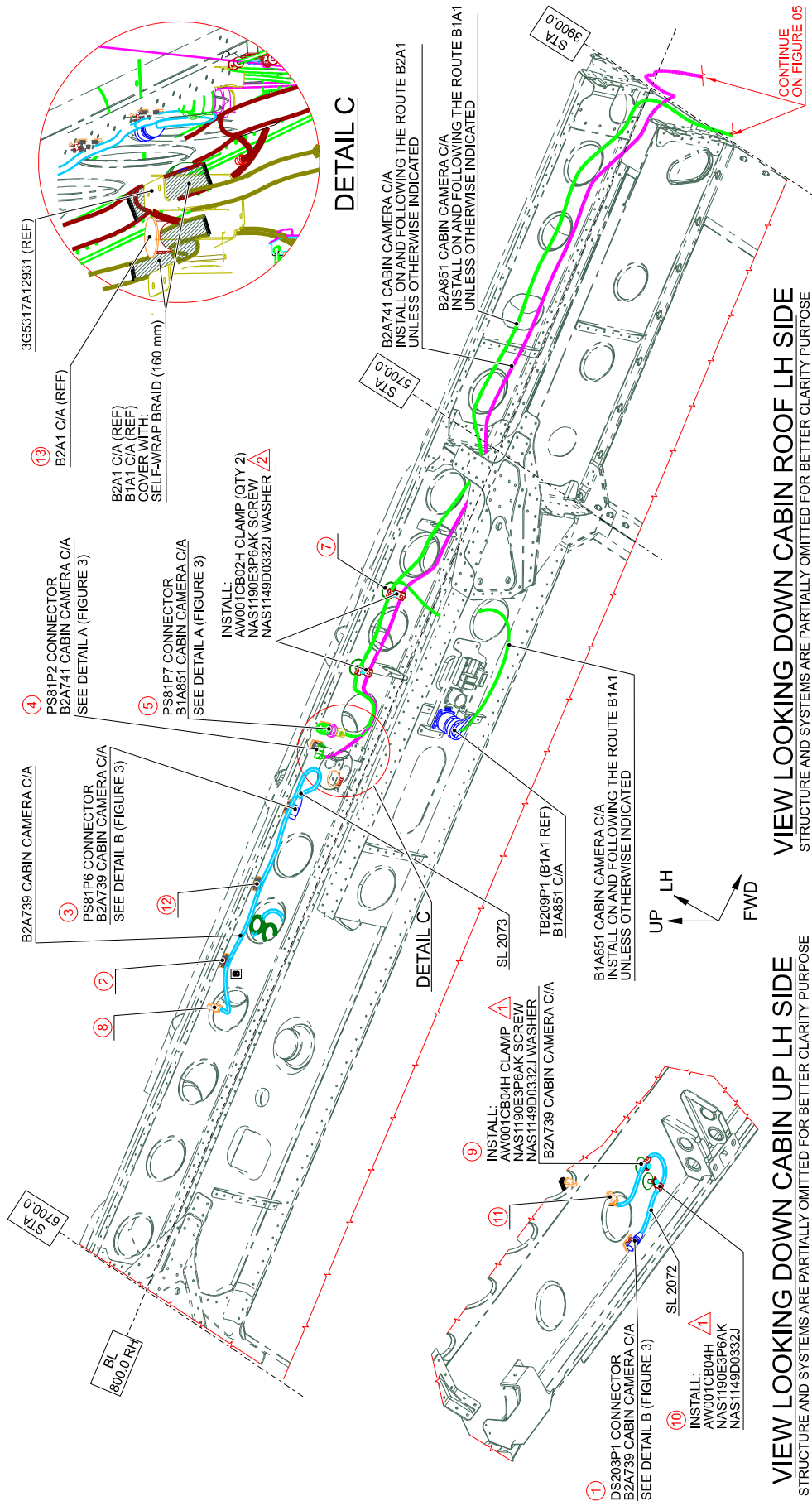

LOCATION NUMBER	PART NUMBER	STA	BL	WL	ORIENTATION
(9)	A388A3E10C	4961	-867	2470	0°
(10)	A388A3E10C	4961	-907	2470	0°
(11)	AW001CL509-N6	5074	-844	2469	0°
(12)	AW001CL509-N6	4850	-798	2620	0°
(13)	AW001CL002C-X2	4581	-686	2656	0°

LOCATION NUMBER	PART NUMBER	STA	BL	WL	ORIENTATION
(5)	AW001CL007-CM	4514	-798	2620	90°
(6)	A388A3E10C	4382	-798	2613	0°
(7)	A388A3E10C	4217	-798	2613	0°
(8)	AW001CL509-N6	5100	-798	2610	0°

LOCATION NUMBER	PART NUMBER	STA	BL	WL	ORIENTATION
(1)	AW001CL007-CM	5081	-962	2470	0°
(2)	AW001CL007-CM	5015	-798	2620	0°
(3)	AW001CL007-CM	4685	-798	2620	0°
(4)	AW001CL007-CM	4554	-798	2620	90°

VIEW LOOKING DOWN CABIN ROOF LH SIDE
STRUCTURE AND SYSTEMS ARE PARTIALLY OMITTED FOR BETTER CLARITY PURPOSE

VIEW LOOKING DOWN CABIN UP LH SIDE
STRUCTURE AND SYSTEMS ARE PARTIALLY OMITTED FOR BETTER CLARITY PURPOSE

Figure 6

RCS CAMERA INSTL
3G9750A01912

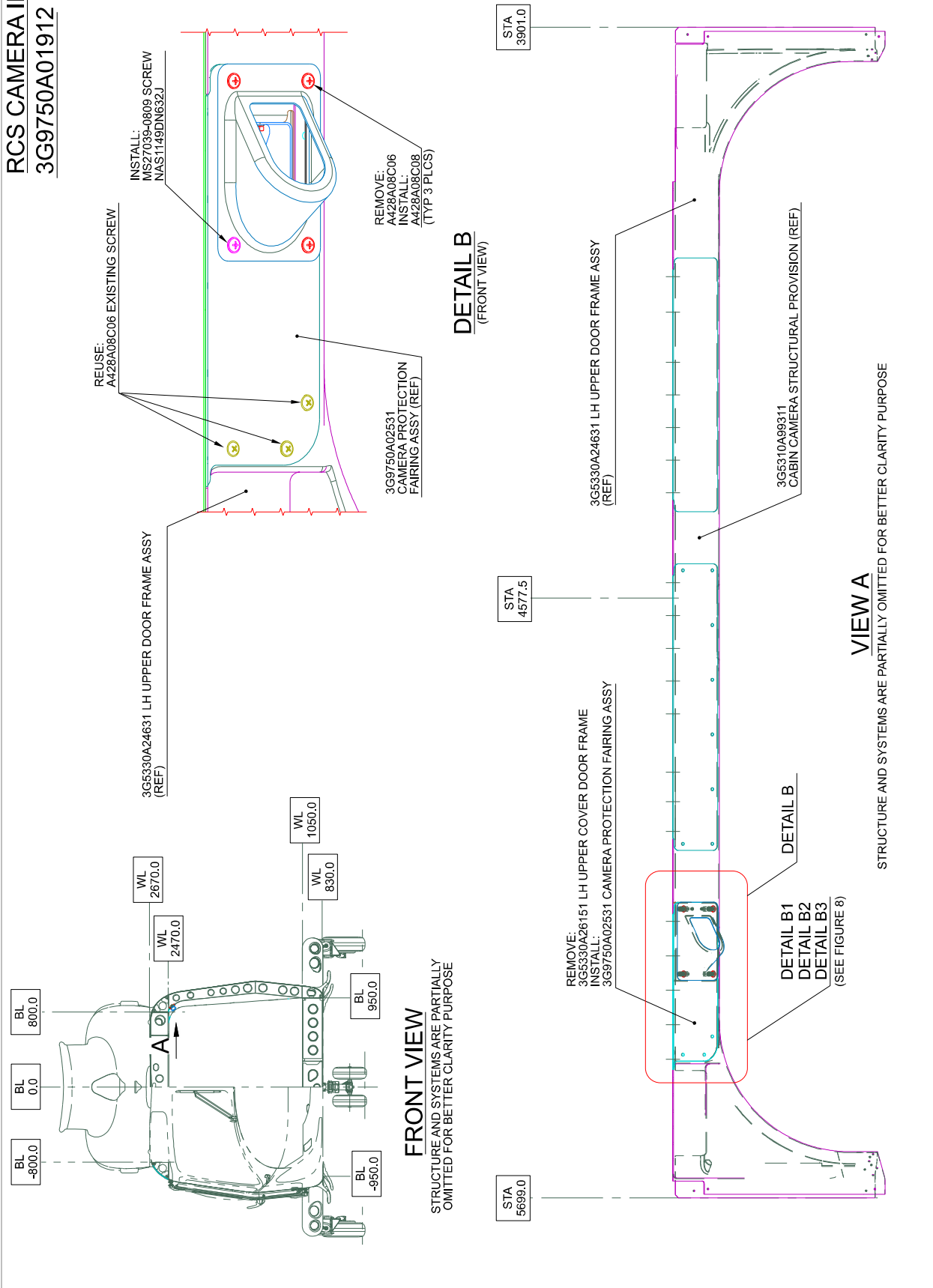

Figure 7

S.B. N°139-675 OPTIONAL
DATE: September 20, 2021
REVISION: B - February 21, 2024

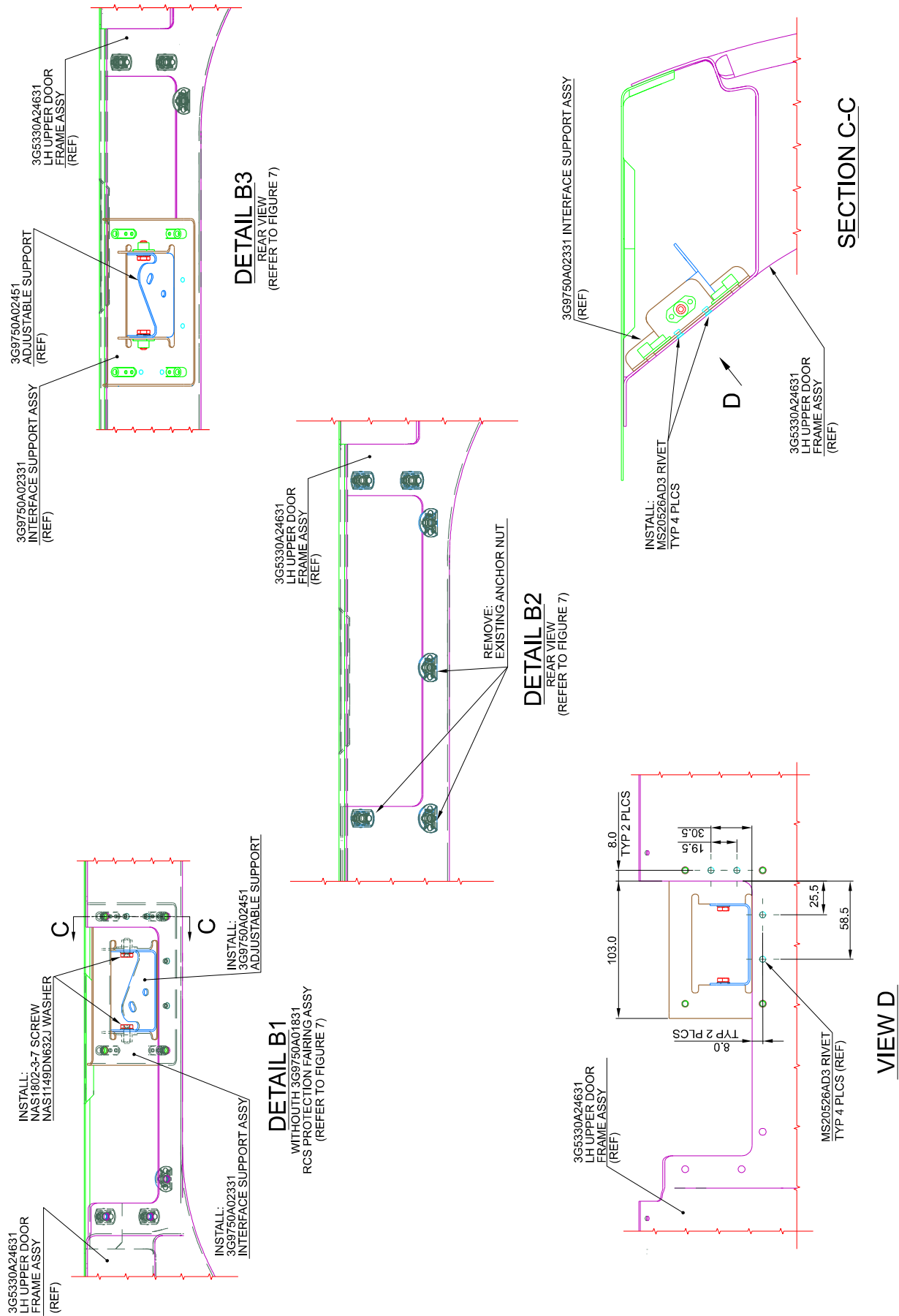

Figure 8

CABIN CAMERA EQUIPMENT INSTL
3G9750A01211

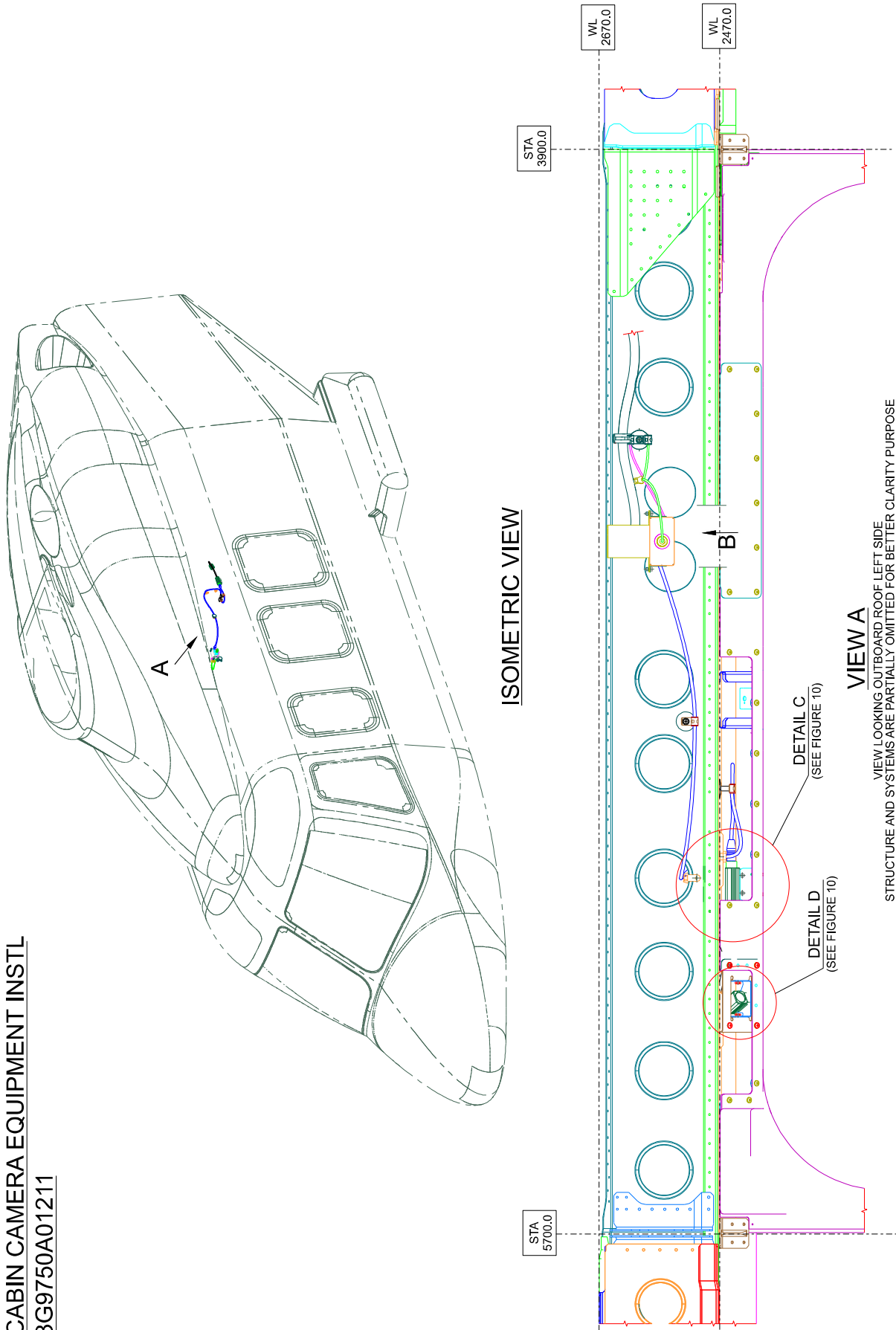

Figure 9

S.B. N°139-675 OPTIONAL
DATE: September 20, 2021
REVISION: B - February 21, 2024

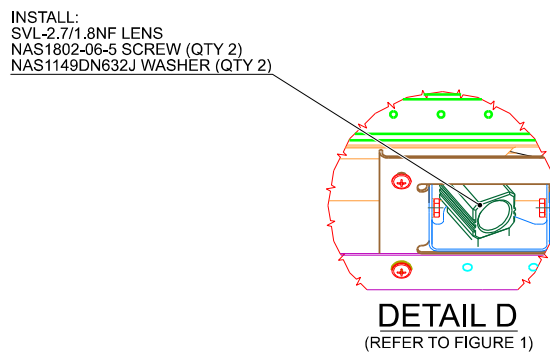
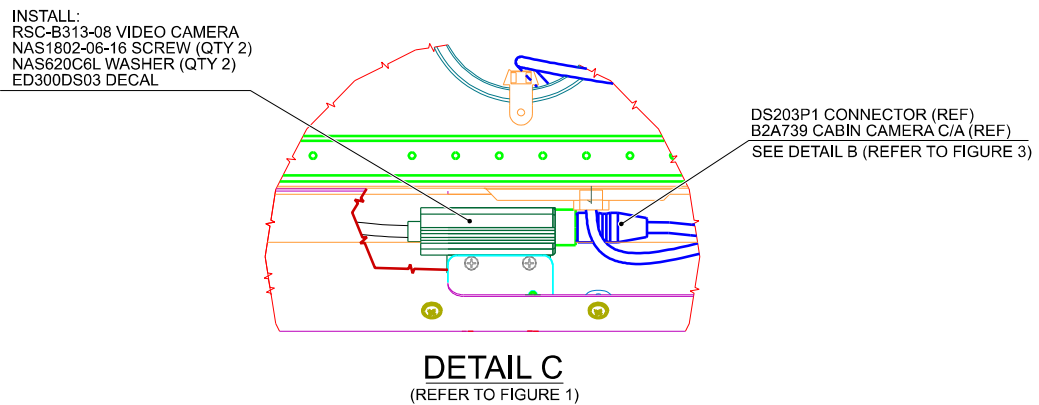
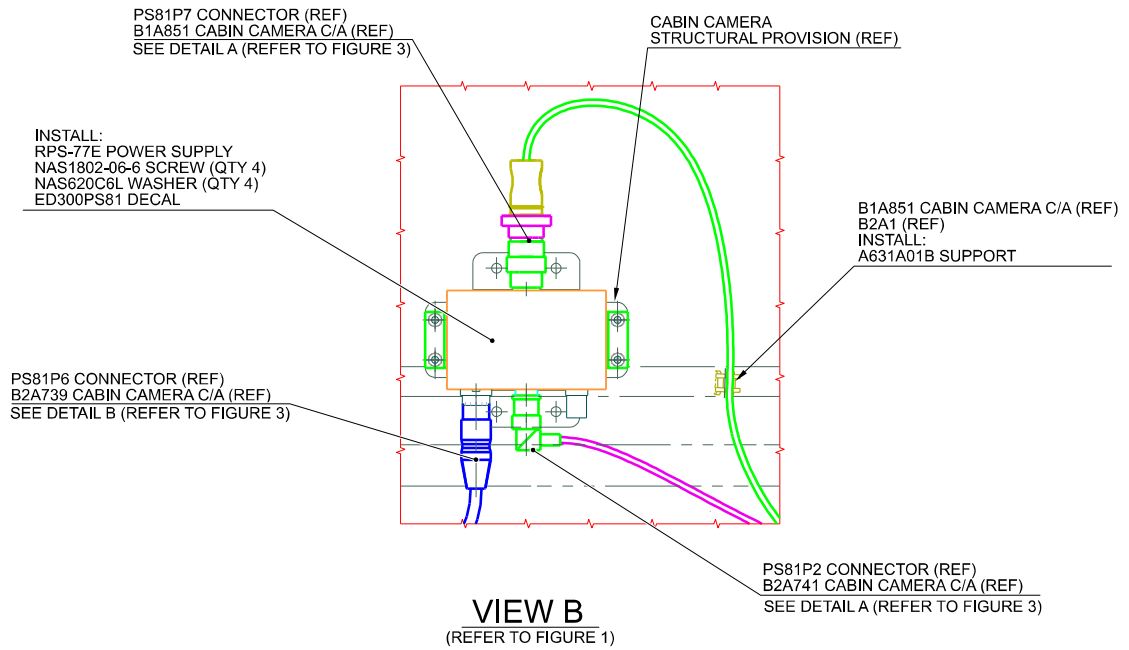

Figure 10

COVER REWORKED
3G5306P48051

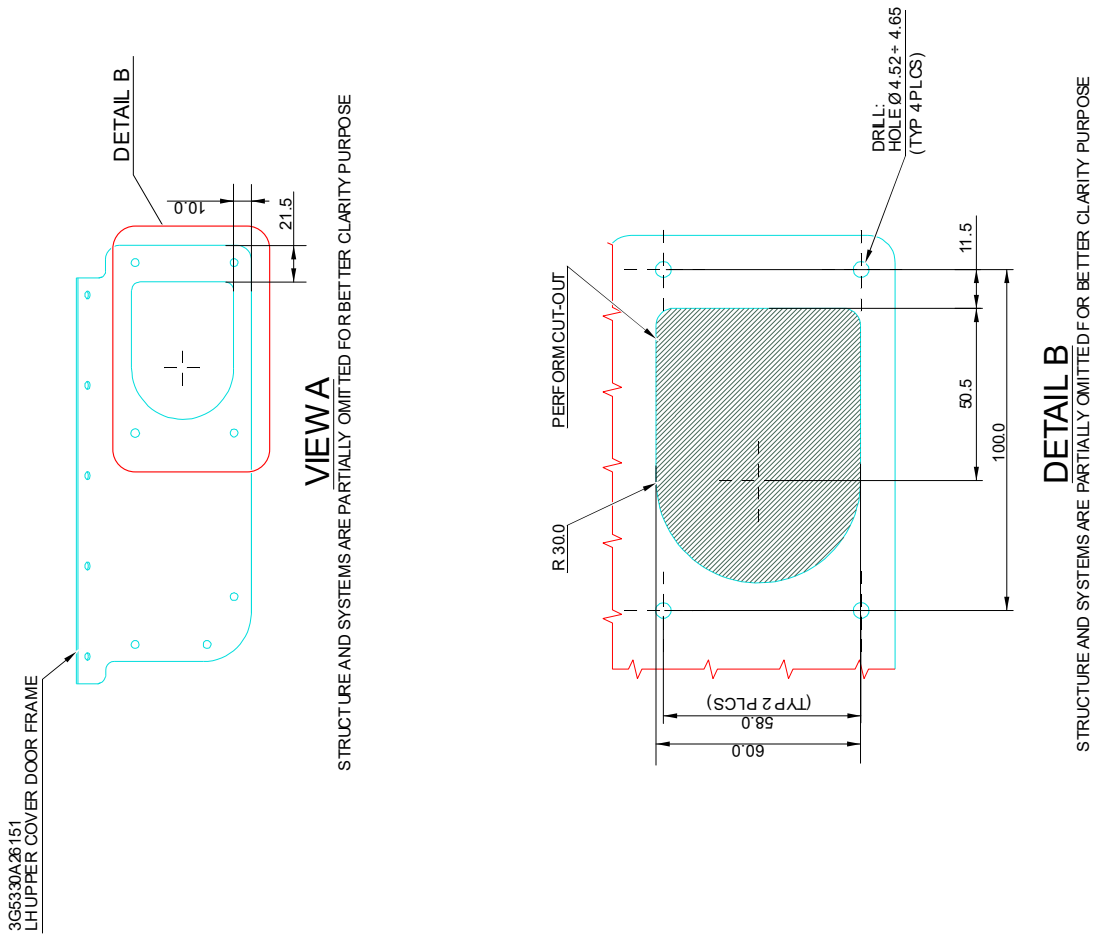

Figure 12

