SERVICE BULLETIN

OPTIONAL

N° 139-587

DATE: March 25, 2021

REV. : A - July 24, 2023

TITLE

ATA 30 - WINDSHIELD WASHING SYSTEM INSTALLATION

REVISION LOG

Helicopters already compliant with previous issues of this Service Bulletin do not need any additional actions.

Revision A is issued in order to introduce the following changes:

- Introduce the installation of screws P/N MS27039-4-09 with a note;
- Replace the wiring diagram in Figure 15 with the correct one;
- Add the installation note for cover P/N 3G5316A39351;
- Update the kit installation to latest design (issue E);
- Update the Service Bulletin document to the latest standard.

Revision bars identify changes.

1. PLANNING INFORMATION

A. EFFECTIVITY

NOTE

If different wiper arms are installed on the helicopter, refer to SB 139-506 Part I and Part II to obtain the correct configuration.

All AB139/AW139 helicopters equipped with wiper arm LH P/N 3G3040V00951 and wiper arm RH P/N 3G3040V01051.

B. COMPLIANCE

At Customer's option.

C. CONCURRENT REQUIREMENTS

N.A.

D. REASON

This Service Bulletin is issued in order to provide the necessary instruction on how to perform the installation of kit windshield washing P/N 4G3040F00116.

Leonardo Helicopters issued this SB for the following reason:

Helicopter Reliability/Maintainability	
Product Improvement	
Obsolescence	
Customization	✓
Product/Capability Enhancement	

E. DESCRIPTION

The windshield washing system supplies a sufficient quantity of cleaning (de-icing) liquid to the two wiper blades spray hoses to clean the windshield surface.

The system consists of a pump and a reservoir installed on the structure inside the helicopter nose, spray nozzles on the two wiper blades and a control panel installed on the interseat console.

F. APPROVAL

The technical content of this Service Bulletin is approved under the authority of DOA nr. EASA.21.J.005. For helicopters registered under other Aviation Authorities, before applying the Service Bulletin, applicable Aviation Authority approval must be checked within Leonardo Helicopters customer portal.

EASA states mandatory compliance with inspections, modifications or technical directives and related time of compliance by means of relevant Airworthiness Directives.

If an aircraft listed in the effectivity embodies a modification or repair not LHD certified and affecting the content of this Service Bulletin, it is responsibility of the Owner/Operator to obtain a formal approval by Aviation Authority having jurisdiction on the aircraft, for any adaptation necessary before incorporation of the present Service Bulletin.

G. MANPOWER

To comply with this Service Bulletin eighty (80) MMH are deemed necessary.

MMH are based on hands-on time and can change with helicopter configuration, personnel and facilities available. MMH are not comprehensive of the overall hours necessary to get access to work areas and to remove all the equipment that interferes with the application of the prescribed instructions.

H. WEIGHT AND BALANCE

WEIGHT (kg)	ARM (mm)	MOMENT (kg mm)
		1.82
LONGITUDINAL BALANCE	1300	2366
LATERAL BALANCE	270	491.4

I. REFERENCES

I.1 PUBLICATIONS

Following Data Modules refer to AMP:

<u>DATA MODULE</u>	<u>DESCRIPTION</u>	<u>PART</u>
DM01 39-A-00-20-00-00A-120A-A	Helicopter on ground for a safe maintenance.	-
DM02 39-A-06-41-00-00A-010A-A	Access doors and panels - General data.	-
DM03 39-A-11-00-01-00A-720A-A	Decal - Install procedure.	-
DM04 39-A-20-10-08-00A-622A-A	Electrical contacts - Crimp	-

<u>DATA MODULE</u>	<u>DESCRIPTION</u>	<u>PART</u>
DM05 39-B-30-42-01-00A-720A-K	Windshield washing pump - Install procedure	-
DM06 39-B-30-42-02-00A-720A-K	Windshield washing fluid reservoir - Install procedure	-
DM07 39-B-30-42-03-00A-520A-K	Windshield wiping/washing control panel - Remove procedure	-
DM08 39-B-30-42-03-00A-720A-K	Windshield wiping/washing control panel - Install procedure	-
DM09 39-A-30-41-00-00A-320A-A	Windshield wiping system - Operation test	-

Following Data Modules refer to CSRP:

<u>DATA MODULE</u>	<u>DESCRIPTION</u>	<u>PART</u>
DM10 CSRP-A-51-42-00-00A-720A-D	Potted inserts - Install procedure	-

I.2 ACRONYMS & ABBREVIATIONS

AMDI	Aircraft Material Data Information
AMP	Aircraft Maintenance Publication
AR	As Required
CSRP	Common Structural Repair Publication
DM	Data Module
DOA	Design Organization Approval
EASA	European Union Aviation Safety Agency
FWD	Forward
IPD	Illustrated Part Data
ITEP	Illustrated tool and equipment publication
LH	Left Hand
LHD	Leonardo Helicopters Division
MMH	Maintenance Man Hours
N.A.	Not Applicable
P/N	Part Number
RH	Right Hand
SB	Service Bulletin

I.3 ANNEX

N.A.

J. PUBLICATIONS AFFECTED

AW139 Illustrated Part Data (IPD).

|

K. SOFTWARE ACCOMPLISHMENT SUMMARY

N.A.

2. MATERIAL INFORMATION

A. REQUIRED MATERIALS

A.1 PARTS

#	P/N	ALTERNATIVE P/N	DESCRIPTION	Q.TY	LVL	NOTE	LOG P/N
1	4G3040F00116		KIT WINDSHIELD WASHING	REF	.		-
2	223350054		Rubber Tube	0.5 m	..		139-587L1
3	2320M-33-1		Pump	1	..		139-587L1
4	3G3040A01651		Pipe Joint	2	..		139-587L1
5	3G3040A02731		WIPER ARM ASSY LH	REF	..		-
6	223350054		Rubber Tube	2 m	...		139-587L1
7	3G3040A02831		WIPER ARM ASSY RH	REF	..		-
8	223350054		Rubber Tube	2 m	...		139-587L1
9	3G3040A02931		WIPER BLADE ASSY LH	REF	..		-
10	3G3040V01151		Wiper Blade Spray Nozzle	1	...		139-587L1
11	3G3040A03031		WIPER BLADE ASSY RH	REF	..		-
12	3G3040V01151		Wiper Blade Spray Nozzle	1	...		139-587L1
13	3G3040L00151		Reservoir	1	..		139-587L1
14	3G3040V00255		Windshield Wiping/Washing Control Panel	1	..		139-587L1
15	3G5310A34211		RESERVOIR WINDSHIELD STRUCTURAL PROVISION	REF	..		-
16	3G5316A39351		Cover	1	...	(1)	139-587L1
17	999-5001-10-103	AW010FP103	Plug	2	...		139-587L1
18	999-5001-10-104	AW010FP104	Plug	4	...		139-587L1
19	MS27039-0804		Screw	1	...		139-587L1
20	NAS1149DN816K		Washer	1	...		139-587L1
21	NAS1836-08-11		Insert	1	...		139-587L1
22	3G5315A82331		Pump Support Assy	1	..		139-587L1
23	3G5315A82731		Connector Support Assy	1	..		139-587L1
24	3G5331A48051		Rubber Shim	1	..		139-587L1
25	3G5331A48151		Rubber Shim	1	..		139-587L1
26	3P5331A82951		Rubber Shim	2	..		139-587L1
27	3P5331A83051		Rubber Shim	2	..		139-587L1
28	4G3040A00113		WINDSCREEN WASHING C/A ELECTRICAL PROVISION	REF	..		-
29	3G9A01A25721	3G9A01A25721A10R	Windscreen Washing C/A (A1A257)	1	...		139-587L1
30	3G9A01B26721	3G9A01B26721A10R	Windscreen Washing C/A (A1B267)	1	...		139-587L1
31	A236A01AB		Nonmetallic Channel	5 m	...		139-587L1
32	A236A02AB		Nonmetallic Channel	5 m	...		139-587L1
33	A236A03AB		Nonmetallic Channel	5 m	...		139-587L1
34	A582A05	EN6049-006-05-5	Nomex	5 m	...		139-587L1
35	A582A08	EN6049-006-08-5	Nomex	5 m	...		139-587L1
36	A582A12	EN6049-006-13-5	Nomex	5 m	...		139-587L1
37	A582A32	EN6049-006-32-5	Nomex	5 m	...		139-587L1
38	AW001CB04H		Clamp	2	...		139-587L1
39	AW001CL001-N6		Support	2	...		139-587L1
40	D38999/33W9R		Cover	1	...		139-587L1
41	ED300S30J1		Decal	1	...		139-587L1
42	M85049/138-33A		Cap	1	...		139-587L1
43	M85049/95-10A-A		Flange	1	...		139-587L1

#	P/N	ALTERNATIVE P/N	DESCRIPTION	Q.TY	LVL	NOTE	LOG P/N
44	NAS1149DN416J		Washer	4	...		139-587L1
45	NAS1802-04-6		Screw	4	...		139-587L1
46	NAS1802-3-6		Screw	1	...		139-587L1
47	NAS1802-3-8		Screw	1	...		139-587L1
48	A115A1916AB		Strip	5 m	..		139-587L1
49	A629A04HS	AW001CK04HS	Tiedown	50	..		139-587L1
50	A954AW015EH		Stencil	1	..		139-587L1
51	B7444-1-1-12C		Sleeve	5 m	..		139-587L1
52	MS20995C32		Lock Wire	0,45 kg	..		139-587L1
53	MS21042L3	NAS9926-3L	Nut	4	..		139-587L1
54	MS27039-1-08		Screw	4	..		139-587L1
55	MS27039-4-12		Screw	4	..		139-587L1
56	MS27039-4-09		Screw	4	..	(2)	-
57	MS35206-228		Screw	2	..		139-587L1
58	MS35206-231		Screw	2	..		139-587L1
59	NAS1149D0332K		Washer	4	..		139-587L1
60	NAS1149D0432K		Washer	4	..		139-587L1
61	NAS1149DN616J		Washer	2	..		139-587L1
62	M39029/56-348		Electrical Contact	11	.		139-587L1
63	M39029/56-351		Electrical Contact	24	.		139-587L1
64	M39029/57-354		Electrical Contact	1	.		139-587L1
65	M39029/58-363		Electrical Contact	4	.		139-587L1

Refer also to IPD for the spares materials required to comply with the AMP DMs referenced in the accomplishment instructions.

A.2 CONSUMABLES

The following consumable materials, or equivalent, are necessary to accomplish this Service Bulletin:

#	SPEC./LHD CODE NUMBER	DESCRIPTION	Q.TY	NOTE	PART
66	199-05-002 Type II, Class 2 Code No. 900004603	Adhesive EA934NA (C397)	AR	(3)	-
67	199-05-002 Type II, Class 3 Code No. 900005009	Adhesive EA 956 AERO (C193)	AR	(3)	-
68	Commercial	Glass dry fabric cloth HexForce 20759 M 1200 (C930)	AR	(3)	-
69	AWMS05-001, Type I, Class B, Grade 2 Code No. 999999999000005966	Sealing compound MC-780 B (C465)	AR	(3)	-
70	199-05-107 Type 1 Class 1 MMM-A-121	Adhesive EC1357 (C455)	AR	(3)	-
71	199-05-152 Type I, Class 1 Code No. 900002972	Adhesive DAPCO 3300 (C227)	AR	(3)	-

Refer also to AMDI for the consumable materials required to comply with the AMP DM referenced in the accomplishment instructions.

A.3 LOGISTIC MATRIX

In order to apply this Service Bulletin, the following Logistic P/N can be ordered in accordance with the applicable notes:

LOGISTIC P/N	Q.TY (PER HELO)	NOTE	PART
139-587L1	1		-
MS27039-4-09	4	(2)	-

NOTES

- (1) This item will be provided as loose item.
- (2) This item must be ordered ONLY for helicopters equipped with machined longeron RH P/N 3G5331A04452.
- (3) Item to be procured as local supply.

B. SPECIAL TOOLS

Refer to ITEP for the special tools required to comply with the AMP DM referenced in the accomplishment instructions.

C. INDUSTRY SUPPORT INFORMATION

Customization.

3. ACCOMPLISHMENT INSTRUCTIONS

GENERAL NOTES

- a) Place an identification tag on all components that are re-usable, including the attaching hardware that has been removed to gain access to the modification area and adequately protect them until their later re-use.
 - b) Shape the cables in order to prevent interference with the structure and the other existing installations, using where necessary suitable lacing cords and plastic cable tiedown.
 - c) Exercise extreme care during drilling operations to prevent instruments, cables and hoses damage.
 - d) After drilling, remove all swarf and sharp edges. Apply on bare metal a light film of primer unless the hole is used for ground connection.
 - e) During the installation of bonding braids or components requiring grounding, clean the surface structure in order to obtain a good ground contact.
 - f) Let adhesive cure at room temperature for at least 24 hours unless otherwise specified.
 - g) Exposed thread surface and nut must be protected using a layer of tectyl according to MIL-C-16173 grade I.
 - h) All lengths are in mm.
1. In accordance with AMP DM 39-A-00-20-00-00A-120A-A, prepare the helicopter on ground for a safe maintenance. Disconnect the battery, all electrical power sources and/or the external power supply.
 2. In accordance with AMP DM 39-A-06-41-00-00A-010A-A and with reference to Figures 1 thru 3, gain access to the area affected by the installation and perform the installation of reservoir windshield structural provision P/N 3G5310A34211 as described in the following procedure:
 - 2.1 With reference to Figure 2 Detail B, perform the indicated cut-out on the panel.
 - 2.2 With reference to Figure 2 Detail B and Section F-F, apply one ply of fiberglass (C930) on the cut-out edges by means of adhesive EA 956 AERO (C193).

- 2.3 With reference to Figure 2 Section F-F, drill a hole $\varnothing 11.48 \div 11.61$ through the RH FWD panel P/N 3G5306P13452.
- 2.4 In accordance with CSRP DM CSRP-A-51-42-00-00A-720A-D and with reference to Figure 2 Section F-F, install insert P/N NAS1836-08-11 by means of adhesive EA934NA (C397).
- 2.5 With reference to Figure 2 Detail B install the screw P/N MS27039-0804 and the washer P/N NAS1149DN816K.
- 2.6 With reference to Figure 3, drill n°4 holes $\varnothing 6.70 \div 6.86$ and n°2 holes $\varnothing 3.86 \div 3.99$ in correspondence of indicated positions on machined longeron RH P/N 3G5331A04453.
- 2.7 With reference to Figure 3 Section D-D, fill with adhesive EA934NA (C397) all around previously drilled holes.
3. With reference to Figure 10 View Q and Section S-S, install n°2 rubber shims P/N 3P5331A83051 by means of adhesive EC1357 (C455).
4. With reference to Figure 10 View Q and Section R-R, install n°2 rubber shims P/N 3P5331A82951 by means of adhesive EC1357 (C455).
5. With reference to Figure 9 View M and Section P-P, install rubber shim P/N 3G5331A48051 and rubber shim P/N 3G5331A48151 by means of adhesive EC1357 (C455).
6. With reference to Figure 9 View M and View N, install indicated strips P/N A115A1916AB by means of adhesive DAPCO 3300 (C227).

NOTE

In case of reservoir P/N 3G3040L00151 removal, with reference to Figure 2 Detail B, install the cover P/N 3G5316A39351 on RH FWD panel P/N 3G5306P13452 using the existing hardware: remove and re-install n°2 screws P/N MS27039-1-06, n°1 washer P/N NAS1149D0316K, the screw P/N MS27039-0804 and the washer P/N NAS1149DN816K as shown in figure.

7. In accordance with AMP DM 39-B-30-42-02-00A-720A-K and with reference to Figure 5 View looking inboard right side, install reservoir P/N 3G3040L00151.
8. In accordance with AMP DM 39-A-11-00-01-00A-720A-A and with reference to Figure 4 View H, install stencil P/N A954AW015EH on RH FWD panel P/N 3G5306P13452 in an area adjacent to reservoir plug.

NOTE

If machined longeron RH P/N 3G5331A04452 is installed on helicopter, install screws P/N MS27039-4-09 instead of screws P/N MS27039-4-12.

9. With reference to Figure 7 Detail W, install pump support assy P/N 3G5315A82331 by means of n°4 screws P/N MS27039-4-12 and n°4 washers P/N NAS1149D0432K.
10. In accordance with AMP DM 39-B-30-42-01-00A-720A-K and with reference to Figure 5 and Figure 7 Detail W, install pump P/N 2320M-33-1 by means of n°4 screws P/N MS27039-1-08, n°4 washers P/N NAS1149D0332K and n°4 nuts P/N MS21042L3.
11. With reference to Figure 5 View looking inboard right side, install rubber tube P/N 223350054 of adequate length between pump P/N 2320M-33-1 and reservoir P/N 3G3040L00151 by means of n°2 straps P/N A629A04HS.
12. With reference to Figure 7 Detail W, install connector support assy P/N 3G5315A82731 by means of n°2 screws P/N MS35206-231 or n°2 screws P/N MS35206-228 (for SAR helicopter) and n°2 washers P/N NAS1149DN616J.
13. With reference to Figure 8 View V, remove the clips from wiper blade spray nozzles P/N 3G3040V01151 and retain for later re-use.
14. With reference to Figure 6 and Figure 8 View V, install n°2 wiper blade spray nozzle P/N 3G3040V01151 on RH and LH wiper blade and relevant clips.
15. With reference to Figure 6 and Figure 7 Section J-J, remove and discard pipe end P/N 3G3040A01751.
16. With reference to Figure 7 Section J-J, install pipe joint P/N 3G3040A01651 on LH shaft assy P/N 3G3040A03131.
17. With reference to Figure 7 Section J-J, use sealing compound MC-780 B (C465) on the external perimeter of pipe joint previously installed.
18. Repeat steps 15 thru 17 on RH shaft assy P/N 3G3040A03231.
19. With reference to Figure 8 View T, install rubber tube P/N 223350054 of adequate length on wiper arm LH P/N 3G3040V00951.
20. With reference to Figure 8 View T, install rubber tube P/N 223350054 of adequate length on wiper arm RH P/N 3G3040V01051.
21. With reference to Figure 7 Section J-J and View K, fix rubber tubes previously installed to pipe joints P/N 3G3040A01651 and to wiper blade spray nozzles P/N 3G3040V01151 by means of n°4 straps P/N A629A04HS.
22. In accordance with AMP DM 39-B-30-42-03-00A-520A-K and with reference to Figure 4, remove windshield wiping control panel P/N 3G3040V00251. Retain existing hardware for later re-use.

23. In accordance with AMP DM 39-A-06-41-00-00A-010A-A and with reference to Figures 11 thru 15, gain access to the area affected by the installation and perform the windscreen washing C/A electrical provision P/N 4G3040A00113 as described in the following procedure:

- 23.1 With reference to Figure 12 View looking nose RH side, at positions n°1, install clamp P/N AW001CB04H using existing hardware.
- 23.2 With reference to Figure 12 View looking nose RH side, at positions n°2, remove screw P/N NAS1802-3-6 and install clamp P/N AW001CB04H on existing hardware by means of screw P/N NAS1802-3-8.

NOTE

Use ending P/N A236A on metallic edges which can damage cable assemblies and where abrasion may occur. Use braided tubing P/N A582A where cable assemblies chafing or contact with structure may occur.

- 23.3 With reference to Figures 11 thru 14, lay down windscreen washing C/A P/N 3G9A01A25721 (A1A257) and windscreen washing C/A P/N 3G9A01B26721 (A1B267) following the existing route unless otherwise indicated on the figures. Secure the cables by means of existing hardware and lacing cord.

NOTE

Where necessary, in accordance with AMP DM 39-A-20-10-08-00A-622A-A, crimp indicated electrical contacts on wires by means of proper crimping tool.

- 23.4 With reference to Figure 15 wiring diagram, perform the electrical connection of C/A A1A257 between MAU1 connector A1-1P2, copilot converter connector B15P1, wiping/washing control panel connector PL12P1, sectioning connectors J101 and J109. If necessary, use the following electrical contacts:
 - Electrical contact P/N M39029/57-354 for A1-1P2 side;
 - Electrical contact P/N M39029/56-351 for B15P1, J101 and J109 sides;
 - Electrical contact P/N M39029/56-348 for PL12P1 side.
- 23.5 With reference to Figure 15 wiring diagram, perform the electrical connection of C/A A1B267 between washer pump connector B16P1, pilot converter connector B14P1, wiping/washing control panel connector PL12P2, terminal board connector TB128P1, sectioning connectors S30J1, P101 and P109. If necessary, use the following electrical contacts:
 - Electrical contact P/N M39029/56-351 for B14P1, B16P1 and S30J1 sides;

- Electrical contact P/N M39029/58-363 for P101 and P109 sides;
 - Electrical contact P/N M39029/56-351 for TB128P1 side;
 - Electrical contact P/N M39029/56-348 for PL12P2 side.
- 23.6 With reference to Figure 12 View looking nose RH side, install connector S30J1 on connector support assy P/N 3G5315A82731 by means of flange P/N M85049/95-10A-A, n° 4 screws P/N NAS1802-04-6 and n°4 washers P/N NAS1149DN416J.
- 23.7 In accordance with AMP DM 39-A-11-00-01-00A-720A-A and with reference to Figure 12, install decal P/N ED300S30J1 in an area adjacent to the previously installed connector S30J1.
- 23.8 Perform a pin-to-pin continuity check of all the electrical connection made.
24. With reference to Figure 12 Detail X, connect the connector B16P1 to the washer pump B16.
25. In accordance with AMP DM 39-B-30-42-03-00A-720A-K and with reference to Figure 4 Detail G, install windshield wiping/washing control panel P/N 3G3040V00255 to interseat console by means of existing hardware.
26. In accordance with AMP DM 39-A-30-41-00-00A-320A-A, perform the windshield wiping system operational test.
27. In accordance with weight and balance changes, update the Chart A (see Rotorcraft Flight Manual, Part II, section 6)
28. Return the helicopter to flight configuration and record for compliance with this Service Bulletin on the helicopter logbook.
29. Gain access to My Communications section on Leonardo WebPortal and compile the "Service Bulletin Application Communication".

As an alternative, send the attached compliance form to the following mail box:

engineering.support.lhd@leonardo.com

and (for North, Central and South America) also to:

AWPC.Engineering.Support@leonardocompany.us

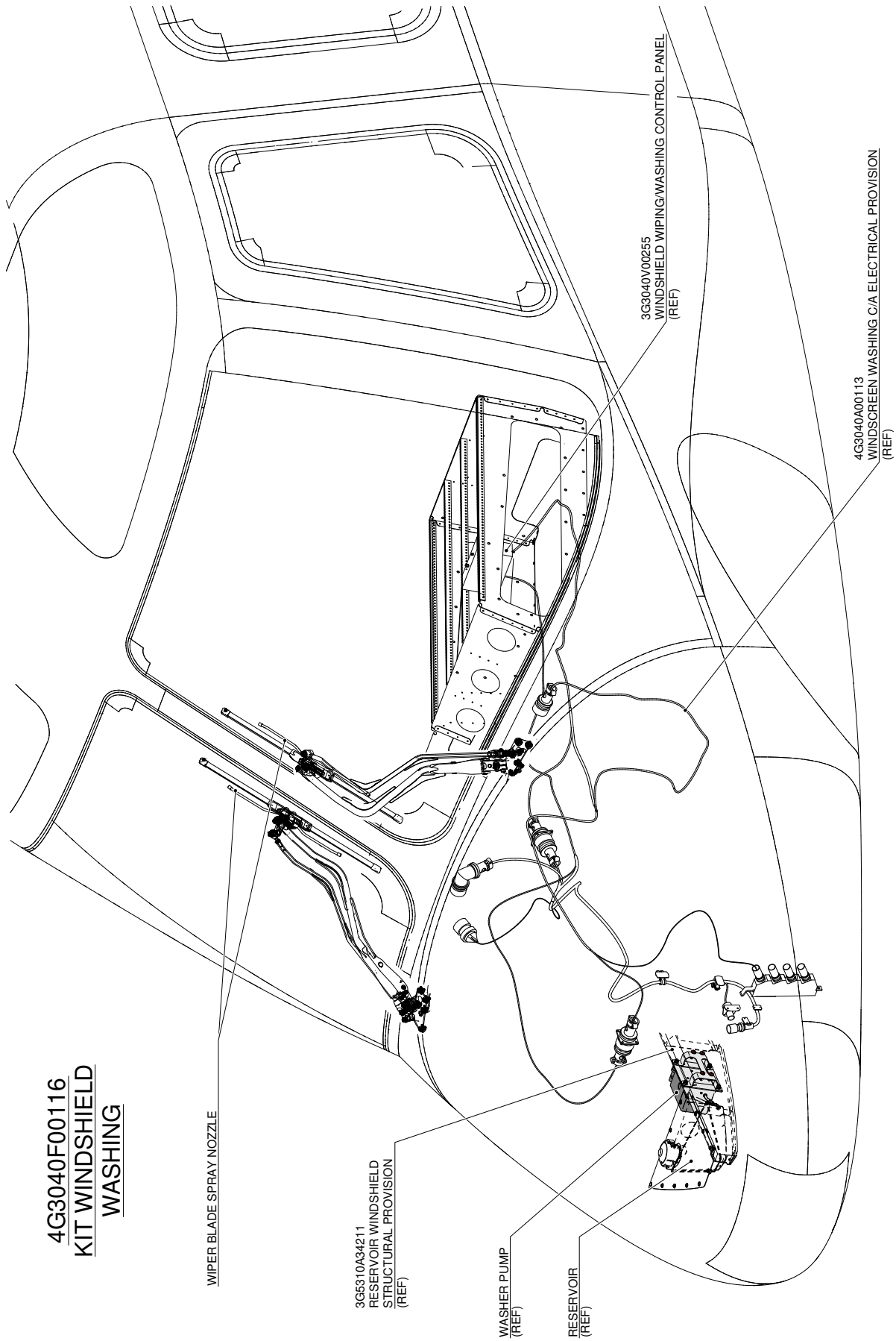

Figure 1

S.B. N°139-587 OPTIONAL
DATE: March 25, 2021
REVISION: A - July 24, 2023

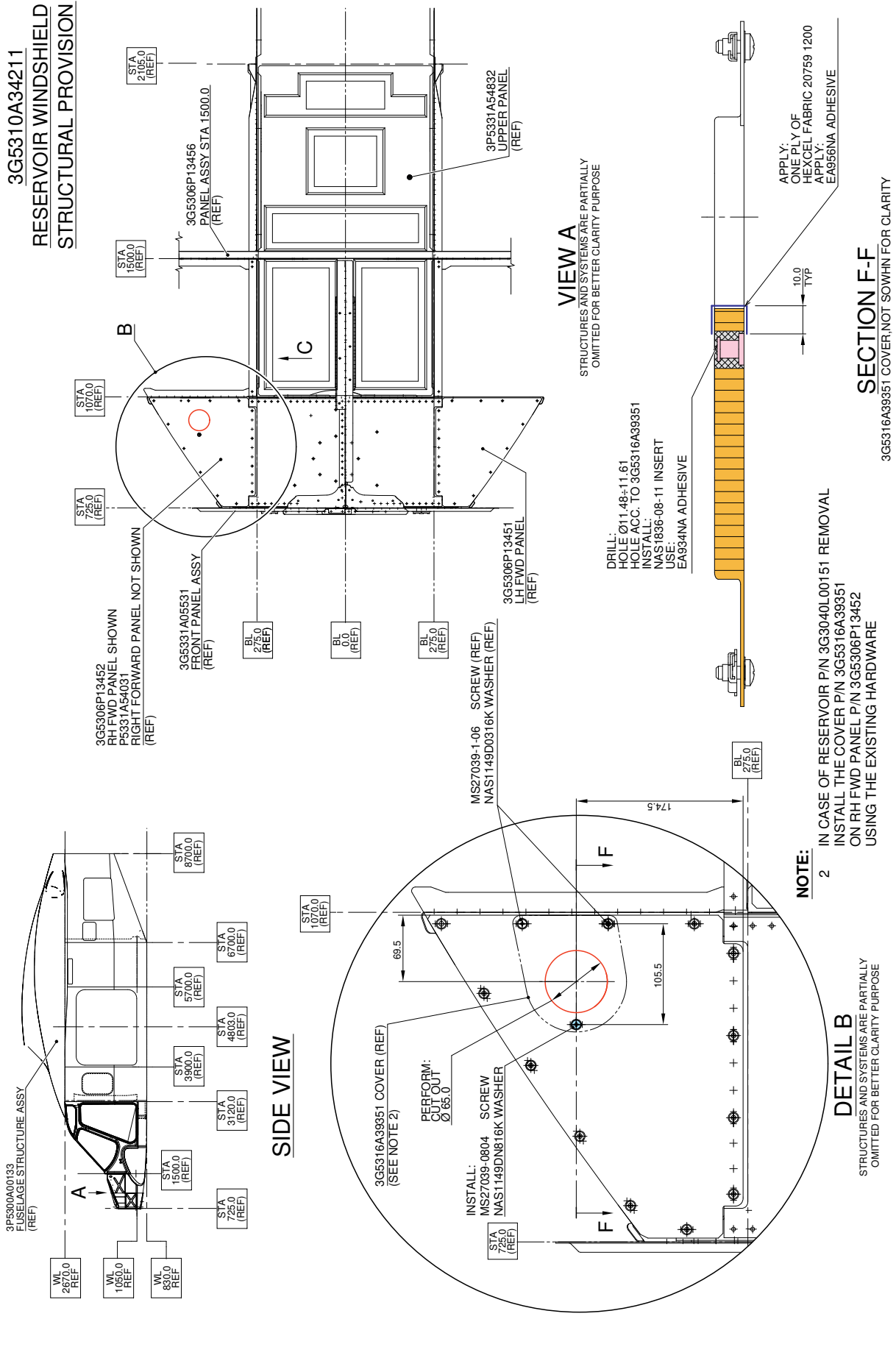
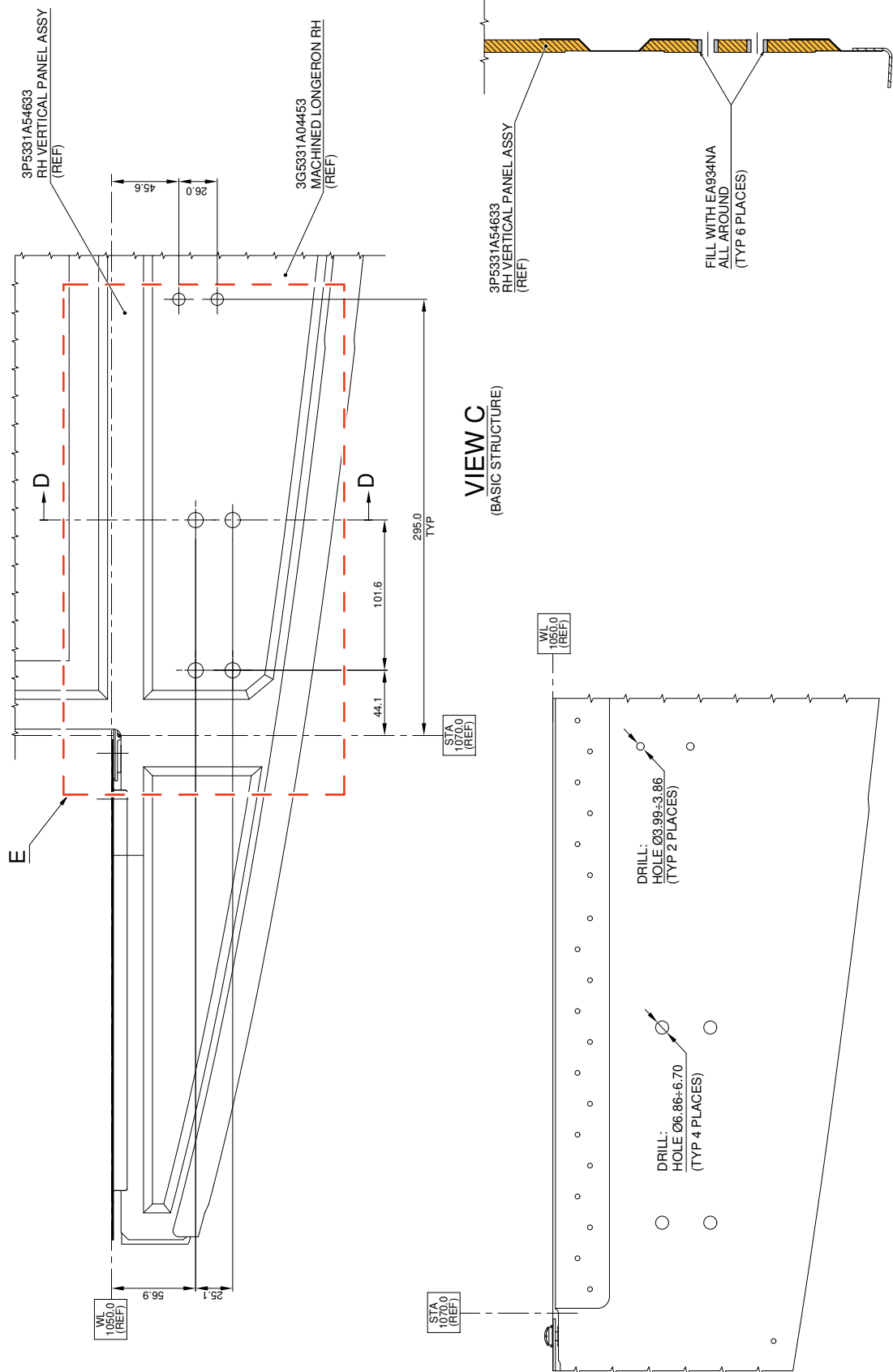

Figure 2



SECTION D-D

DETAIL
(BASIC STRUCTURE AND SAR VARIANT HOLES)

Figure 3

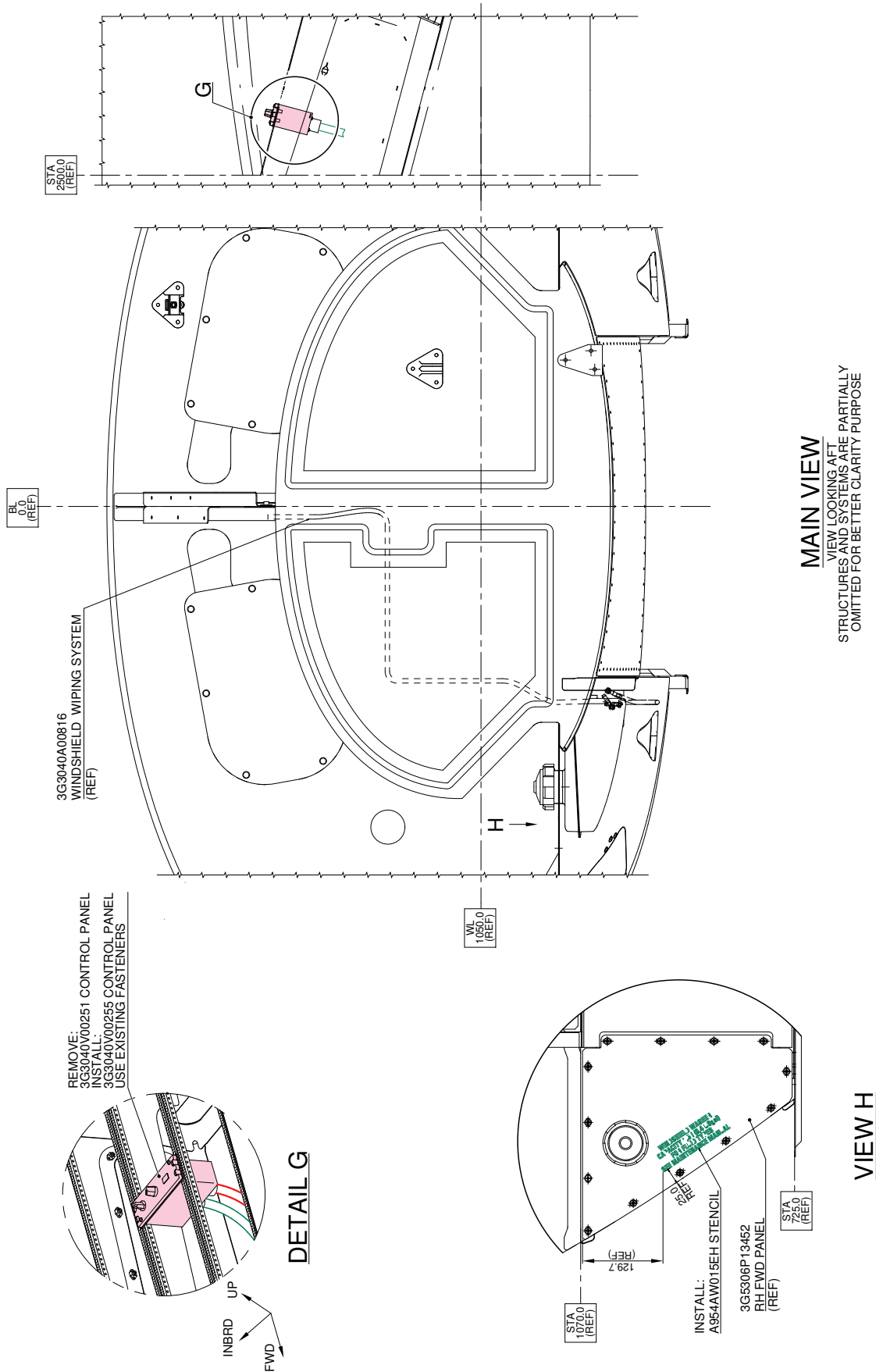
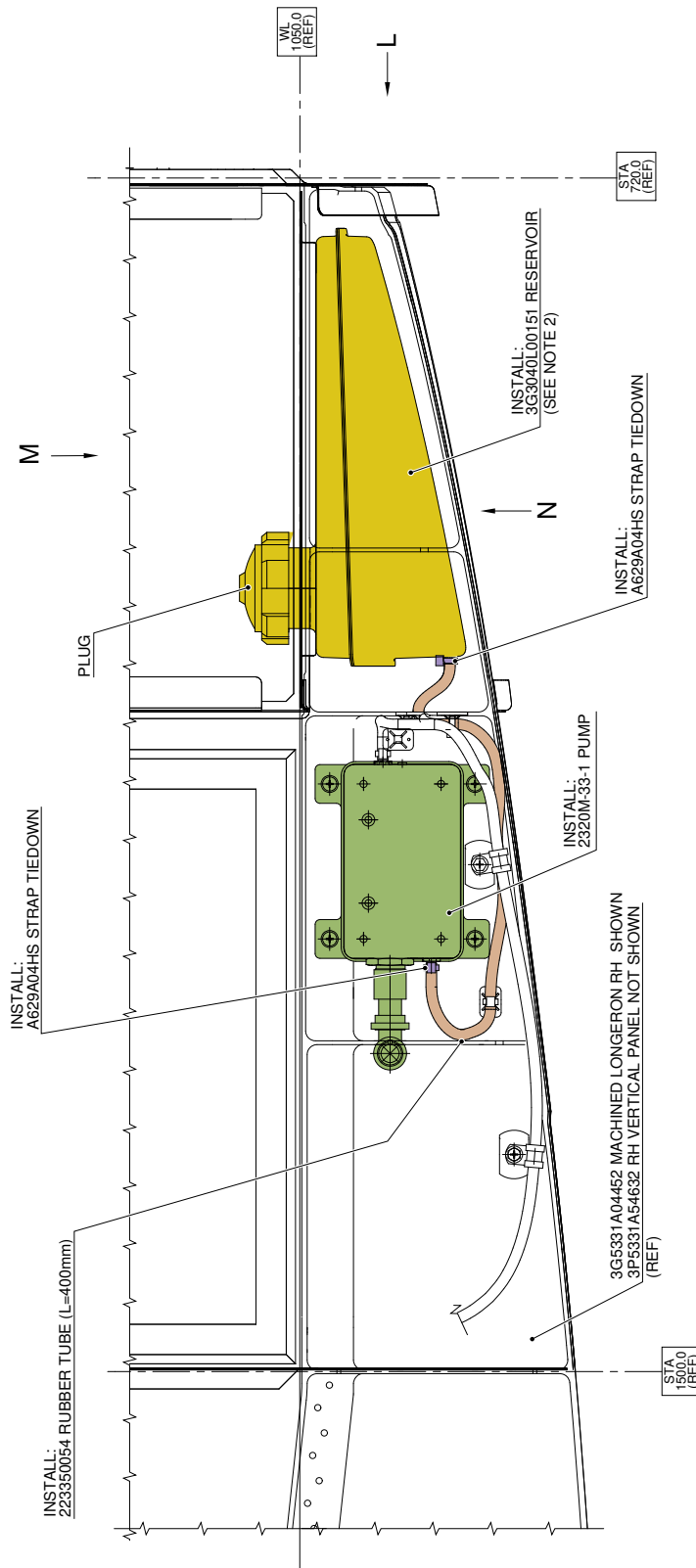

Figure 4



VIEW LOOKING INBOARD RIGHT SIDE

STRUCTURES AND SYSTEMS ARE PARTIALLY OMITTED FOR BETTER CLARITY PURPOSE

- NOTE:**
- 2 IN CASE OF RESERVOIR P/N 3G3040L00151 REMOVAL
INSTALL THE COVER P/N 3G5316A39351
ON RH FWD PANEL P/N 3G5306P13452
USING THE EXISTING HARDWARE

Figure 5

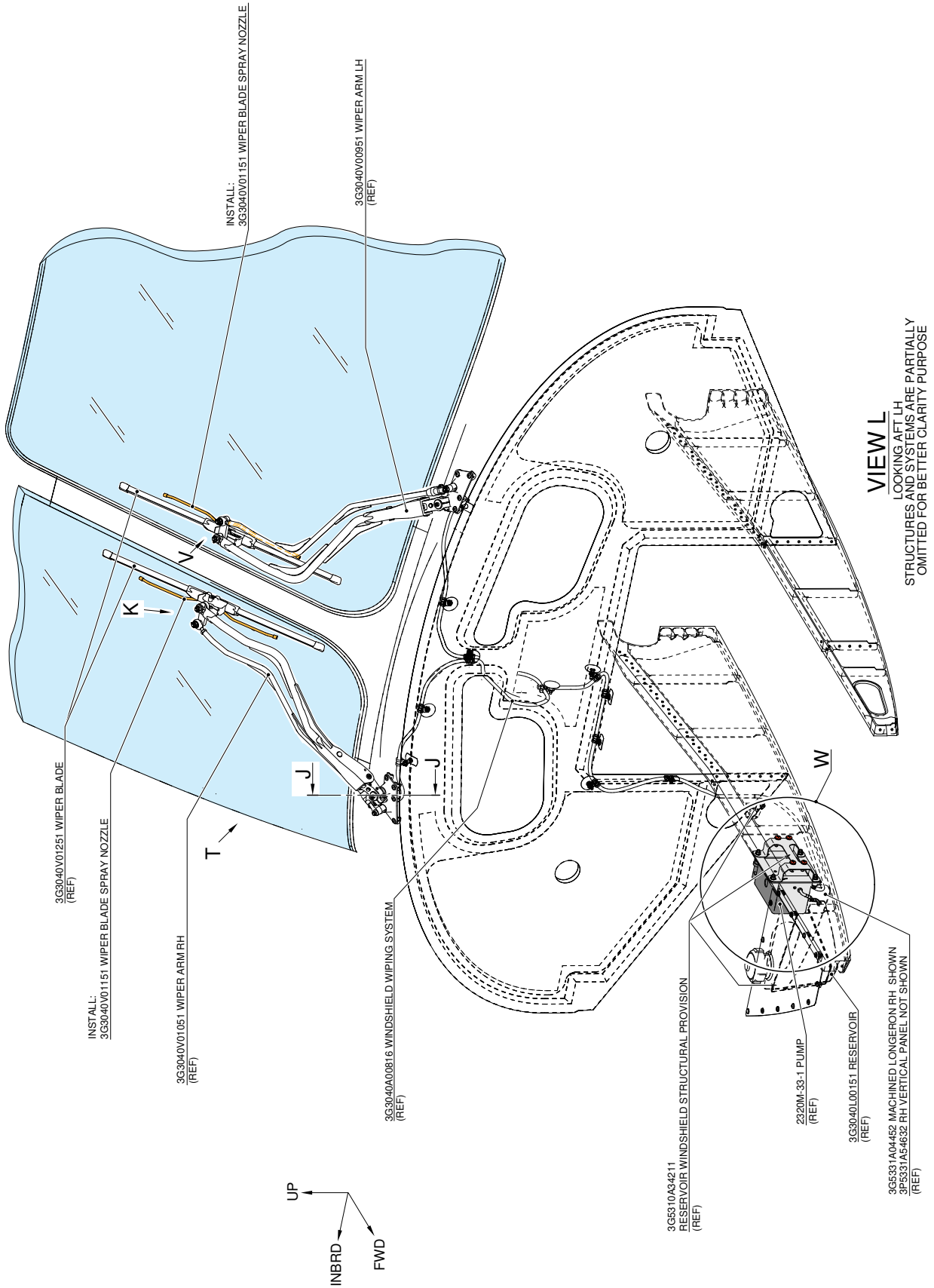
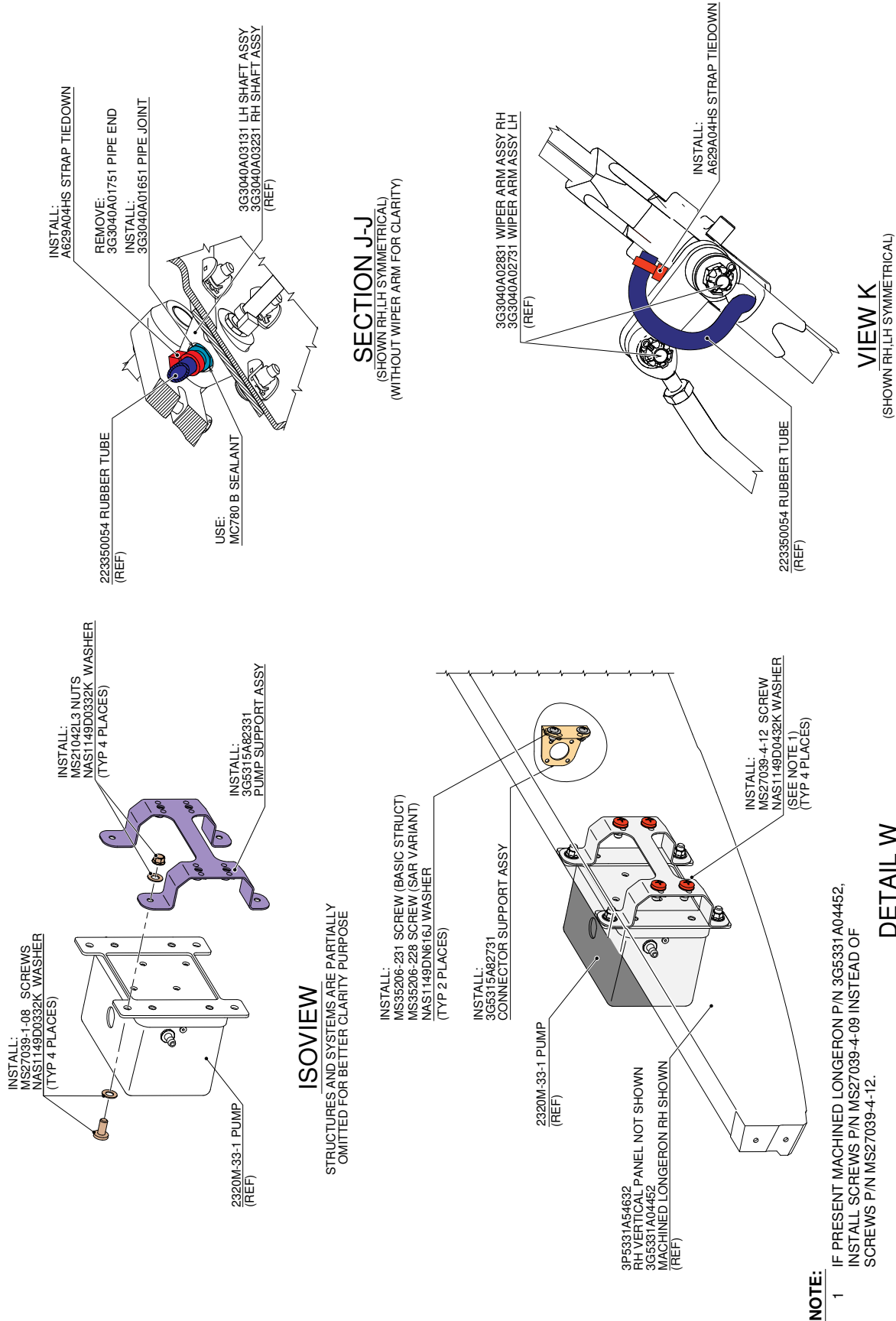

Figure 6



DETAIL W

STRUCTURES AND SYSTEMS ARE PARTIALLY OMITTED FOR BETTER CLARITY PURPOSE

NOTE:

- 1 IF PRESENT MACHINED LONGERON P/N 3G5331A04452, INSTALL SCREWS P/N MS27039-4-09 INSTEAD OF SCREWS P/N MS27039-4-12.

Figure 7

3G3040A02831
WIPER ARM ASSY RH

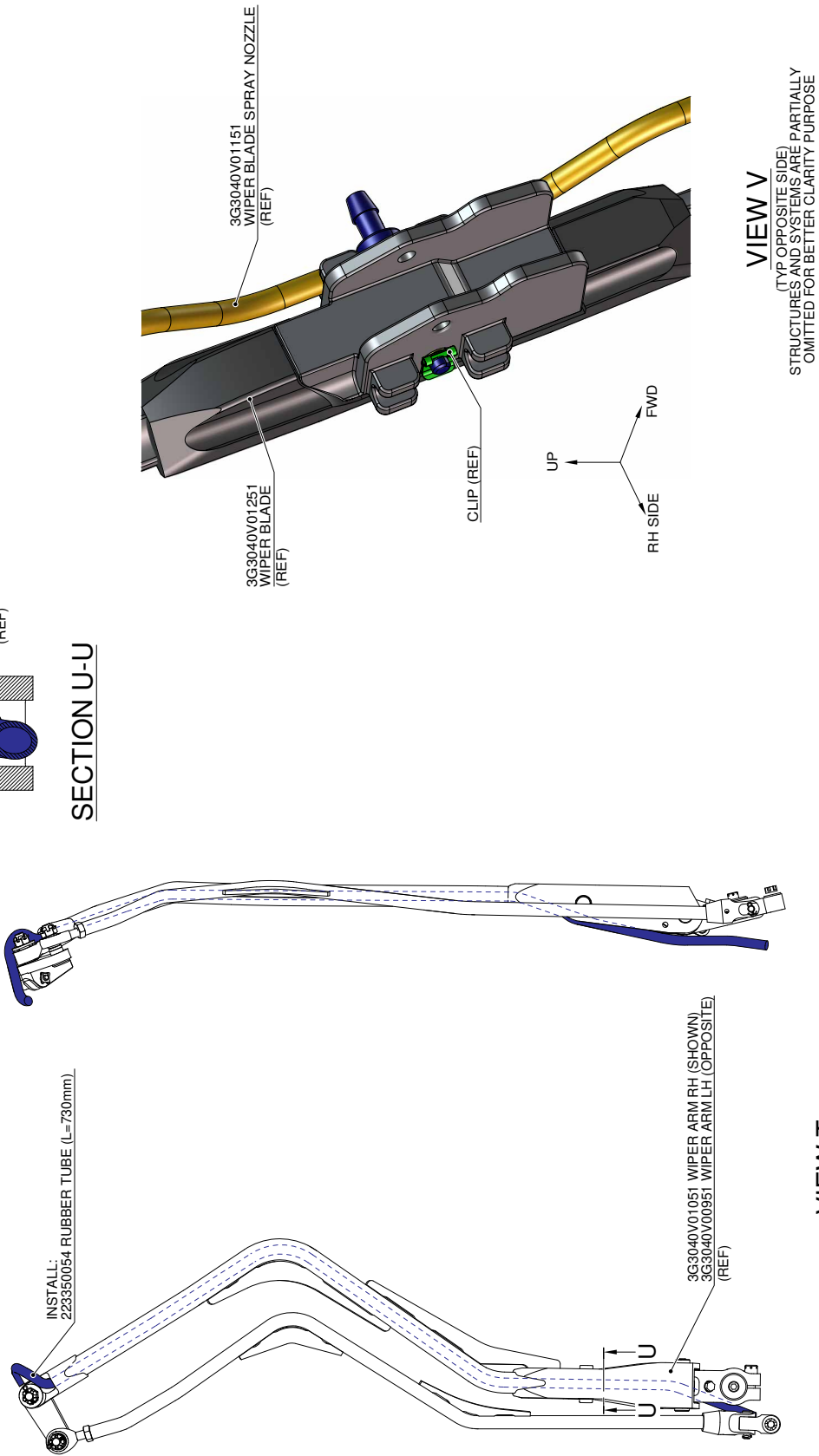

Figure 8

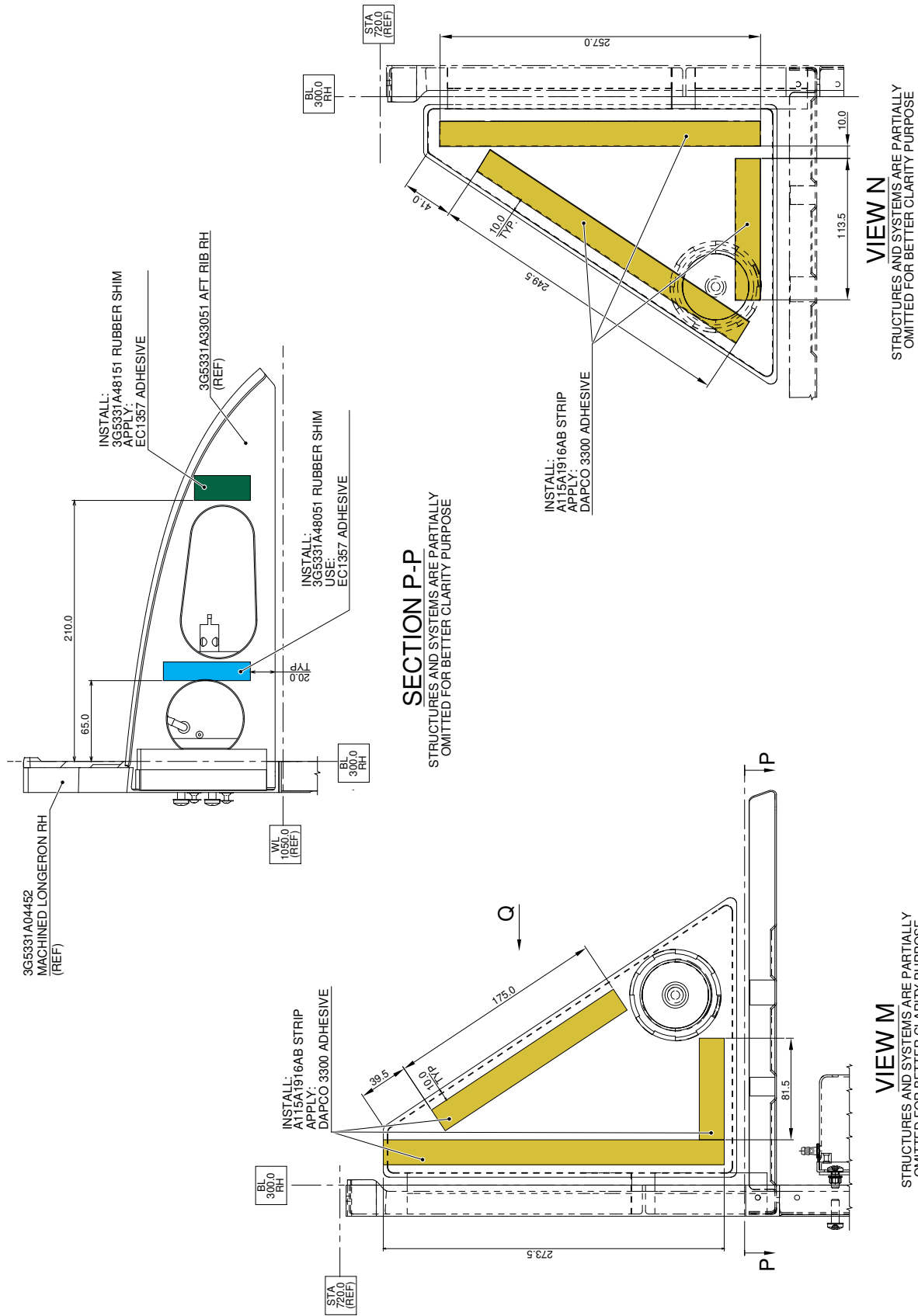
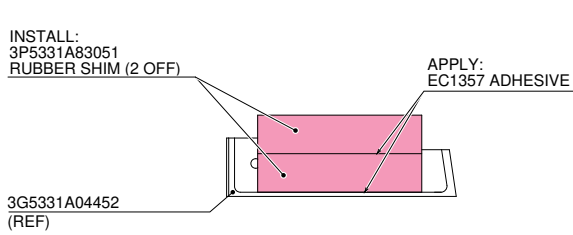
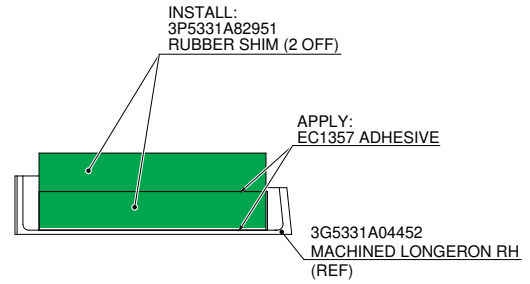

Figure 9

S.B. N°139-587 OPTIONAL
DATE: March 25, 2021
REVISION: A - July 24, 2023



SECTION S-S
STRUCTURES AND SYSTEMS ARE PARTIALLY
OMITTED FOR BETTER CLARITY PURPOSE



SECTION R-R
STRUCTURES AND SYSTEMS ARE PARTIALLY
OMITTED FOR BETTER CLARITY PURPOSE

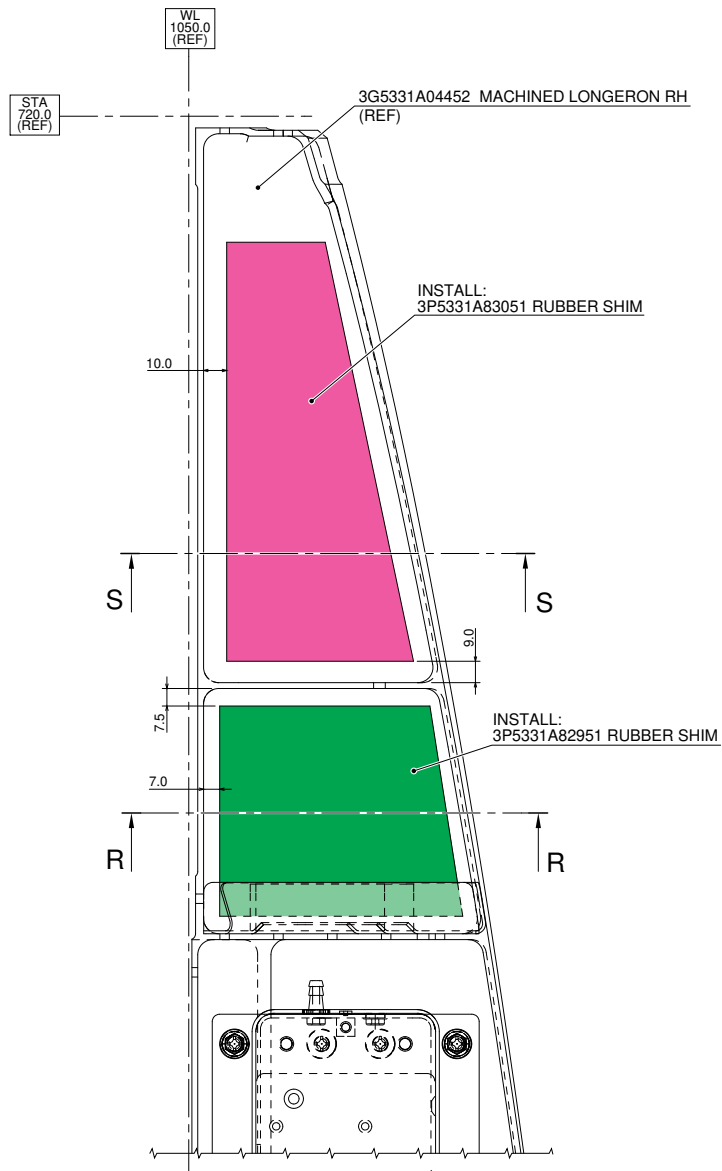

VIEW Q
3G3040L00151 RESERVOIR IS OMITTED FOR CLARITY
STRUCTURES AND SYSTEMS ARE PARTIALLY
OMITTED FOR BETTER CLARITY PURPOSE

Figure 10

4G3040A00113
WINDSCREEN WASHING C/A
ELECTRICAL PROVISION

XYZ INDICATES WHERE GIVEN COORDINATES
ARE LOCATED ON SUPPORT. SEE COORD. TABLE
LOCATION OF SUPPORT CAN BE BONDED WITH IN ± 5 MM OF
GIVEN COORDINATES. UNLESS OTHERWISE MENTIONED
ORIENTATION OF SUPPORT CAN BE BONDED WITH IN $\pm 5^\circ$ OF
GIVEN VALUE. UNLESS OTHERWISE MENTIONED.



AW001CL001-N6

ORIENTATION OF CABLE SUPPORTS
DIAGRAM IS BASIC FOR ORIENTATION OF
ALL CABLE SUPPORTS IN RELATIONSHIP
WITH H/C AXIS SYSTEM.
FOR ORIENTATION OF SUPPORT SEE
COORDINATES TABLE

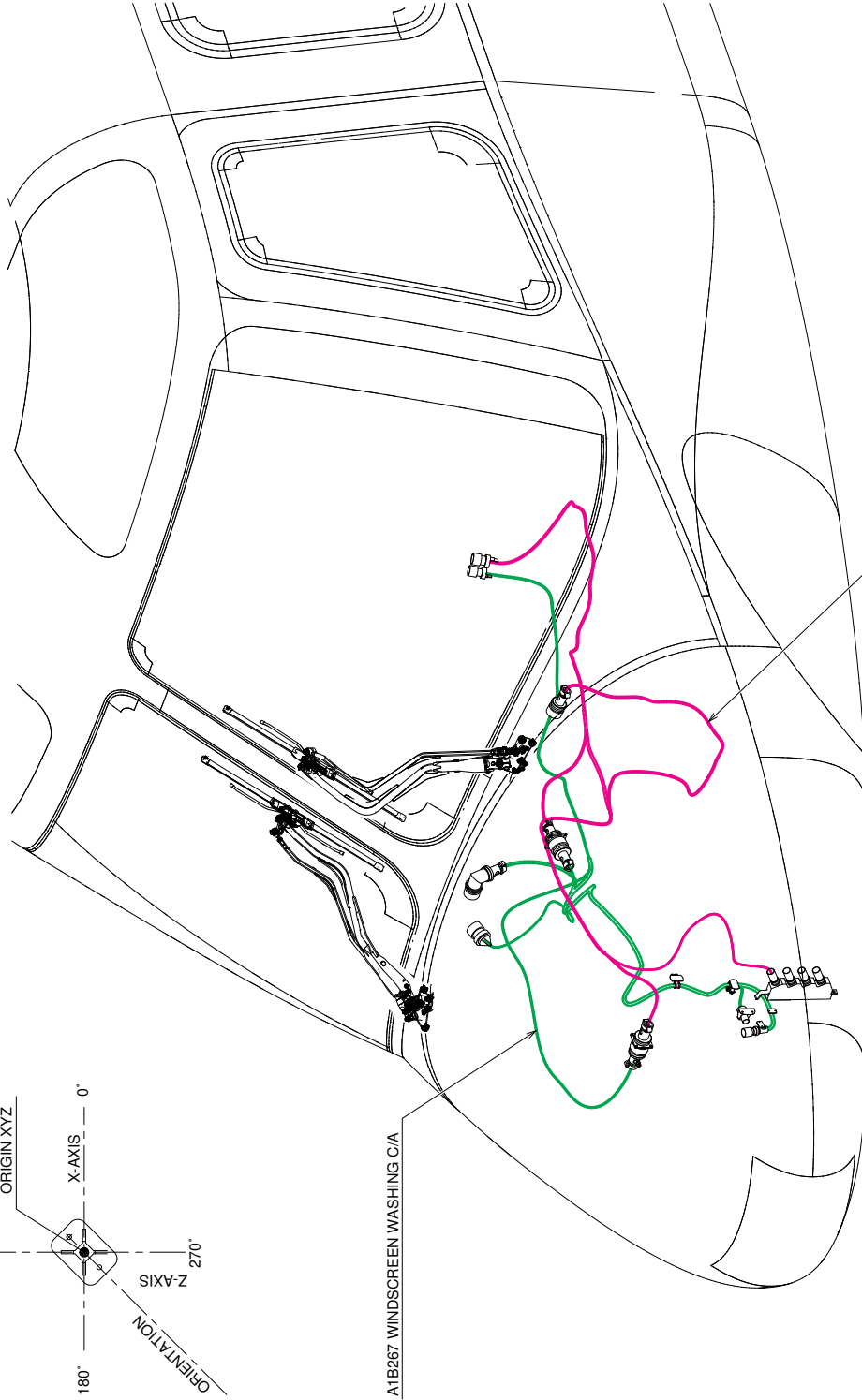
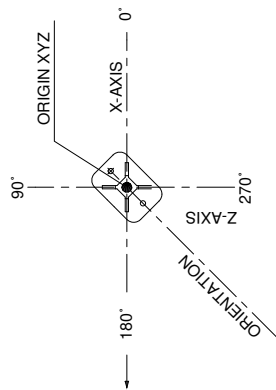
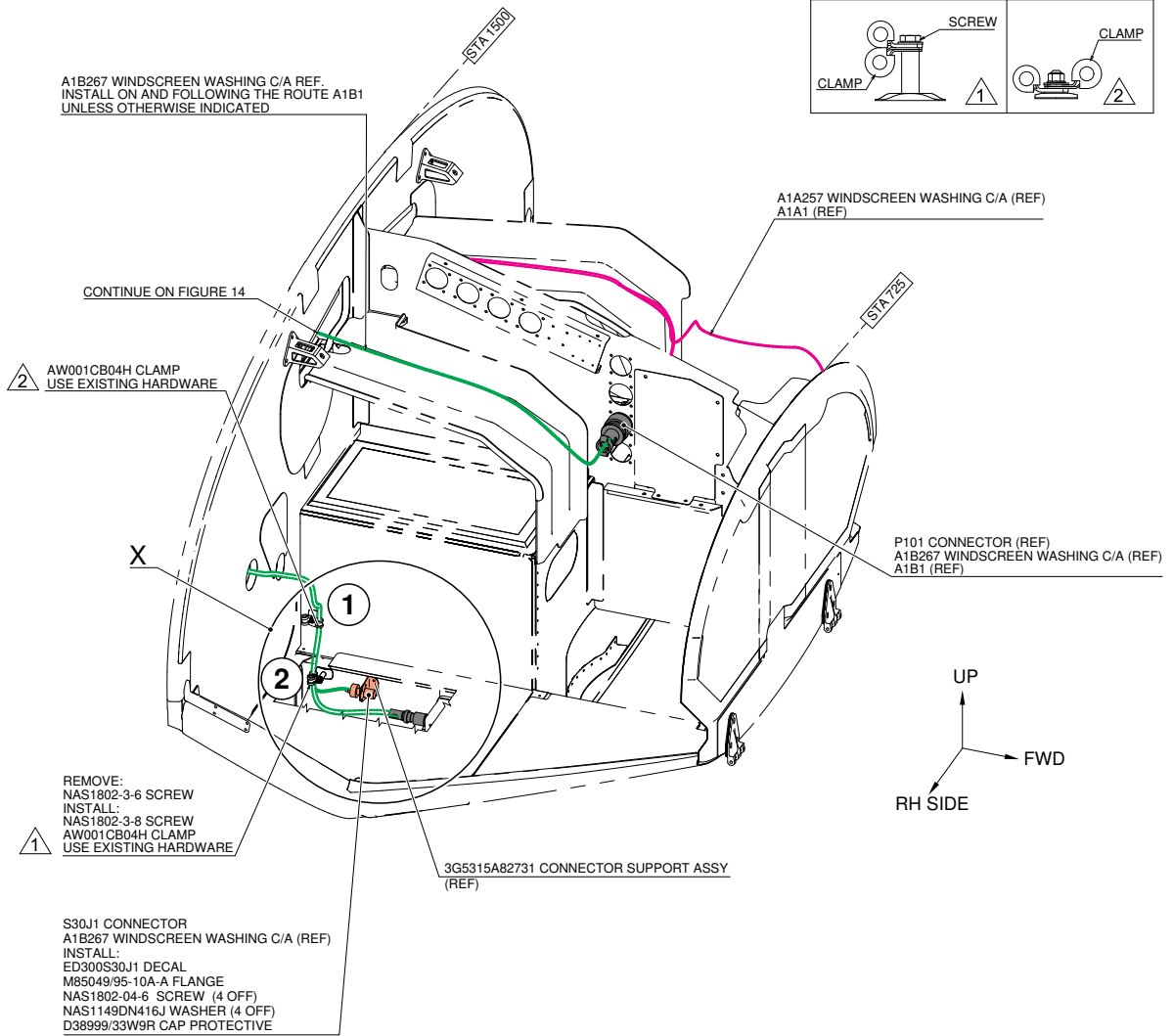

Figure 11

S.B. N°139-587 OPTIONAL
DATE: March 25, 2021
REVISION: A - July 24, 2023



VIEW LOOKING NOSE RH SIDE

STRUCTURES AND SYSTEMS ARE PARTIALLY
OMITTED FOR BETTER CLARITY PURPOSE

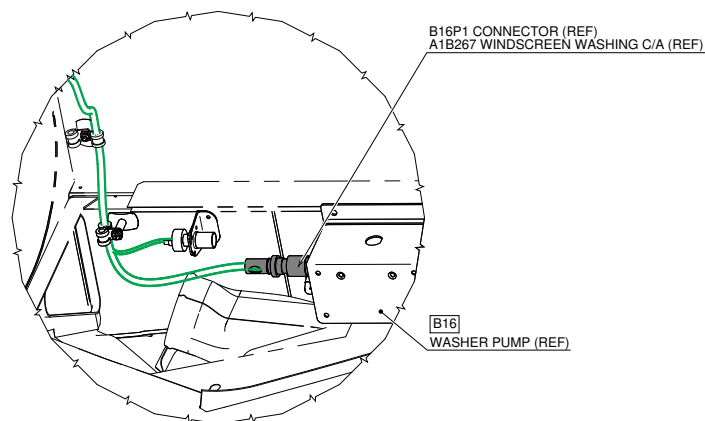

DETAIL X

STRUCTURES AND SYSTEMS ARE PARTIALLY
OMITTED FOR BETTER CLARITY PURPOSE

Figure 12

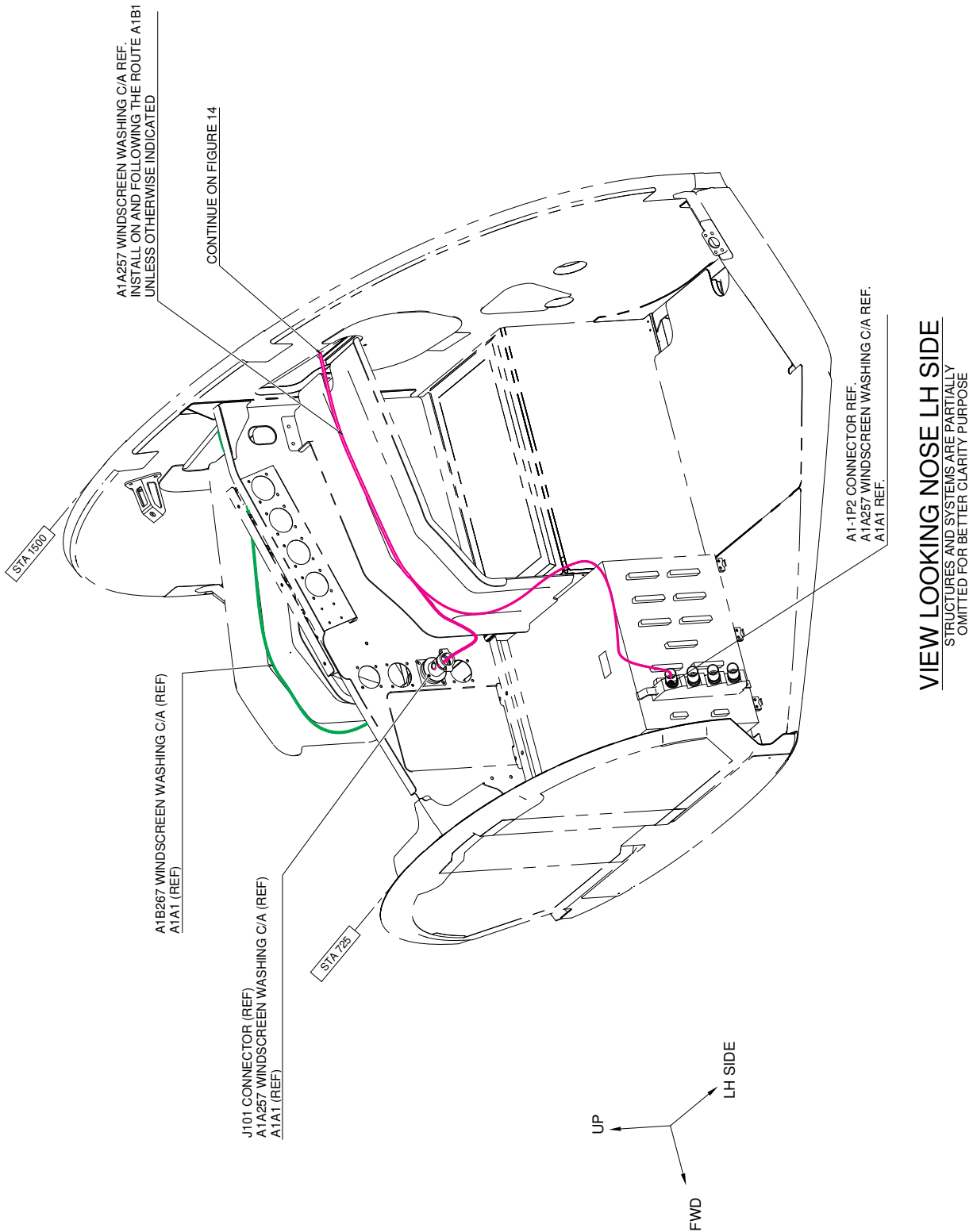
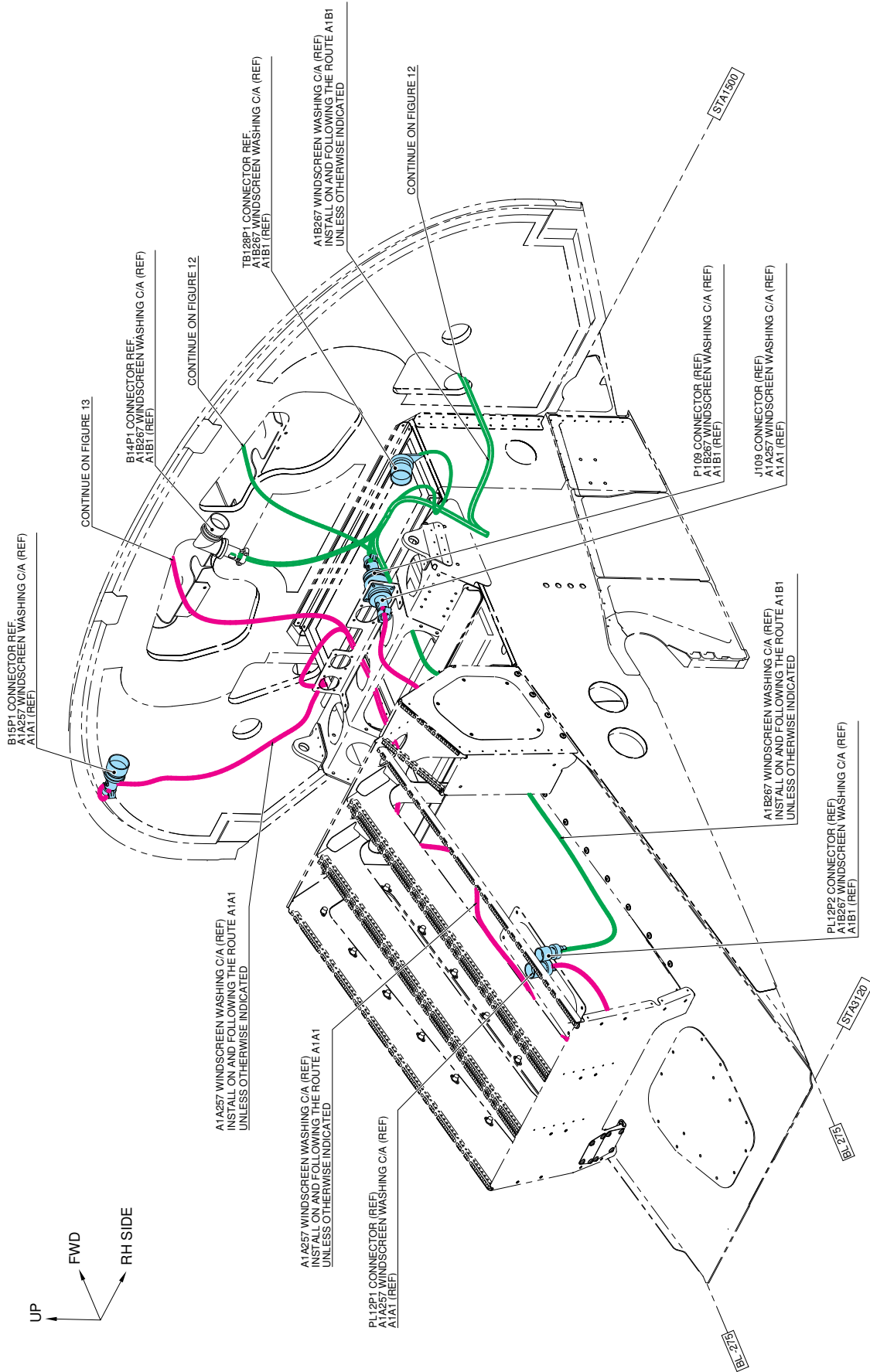
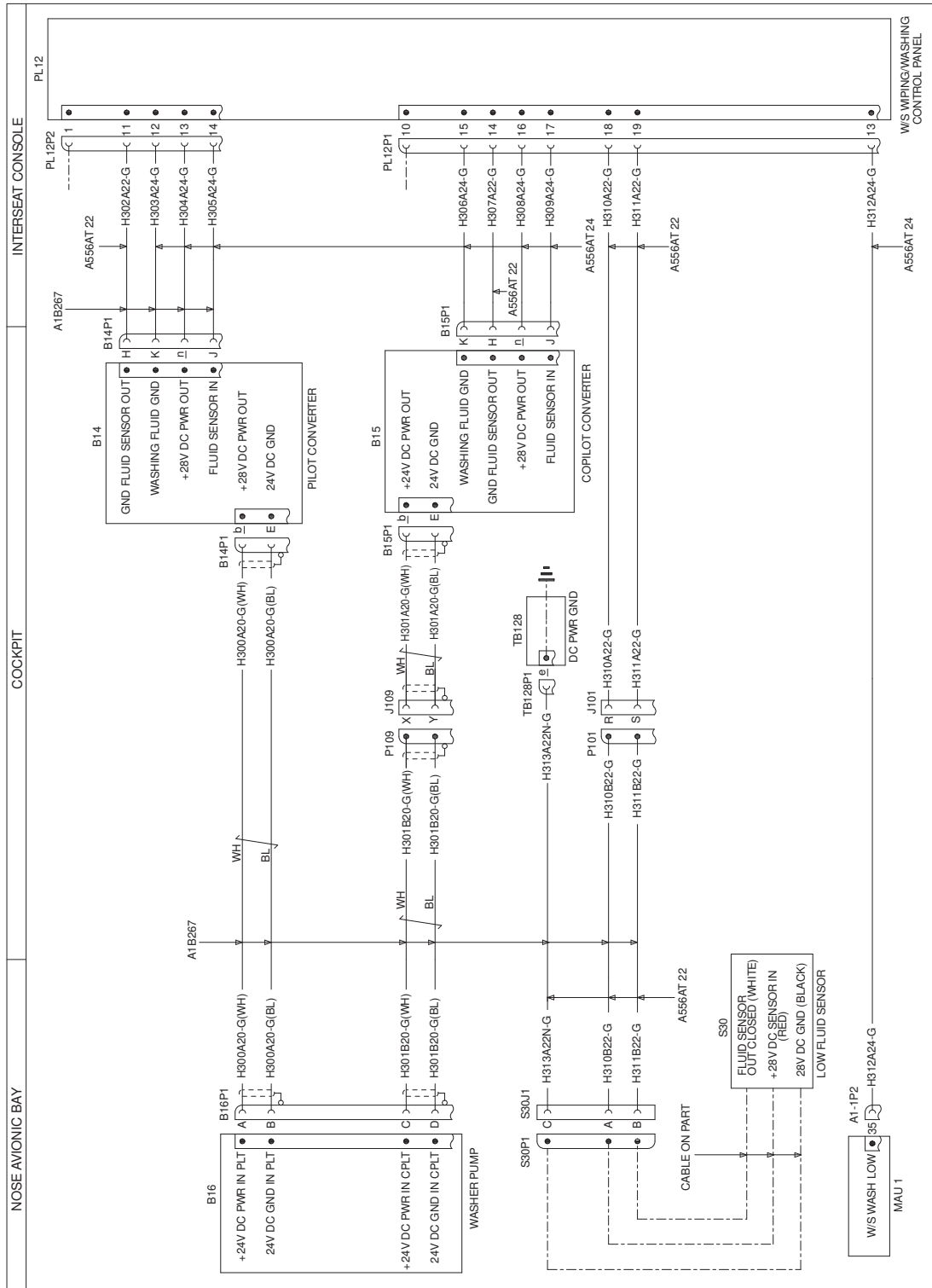

Figure 13



VIEW LOOKING COCKPIT
STRUCTURES AND SYSTEMS ARE PARTIALLY
OMITTED FOR BETTER CLARITY PURPOSE

Figure 14



3G3040W00221
WIRING DIAGRAM WINDSCREEN WASHING

FUNCTIONAL NOTES
ALL CABLES ARE IN LOOM A1A257 UNLESS SPECIFIED
ALL CABLES ARE OF TYPE A561AT2 20 UNLESS SPECIFIED

Figure 15

S.B. N°139-587 OPTIONAL
DATE: March 25, 2021
REVISION: A - July 24, 2023

Please send to the following address:		SERVICE BULLETIN COMPLIANCE FORM		Date:
LEONARDO S.p.A. CUSTOMER SUPPORT & SERVICES - ITALY		Number:		
PRODUCT SUPPORT ENGINEERING & LICENSES DEPT. Via Giovanni Agusta, 520 21017 Cascina Costa di Samarate (VA) - ITALY Tel.: +39 0331 225036 Fax: +39 0331 225988		Revision:		
Customer Name and Address:		Telephone:		
		Fax:		
		B.T. Compliance Date:		
Helicopter Model	S/N	Total Number	Total Hours	T.S.O.
Remarks:				
Information: We request your cooperation in filling this form, in order to keep out statistical data relevant to aircraft configuration up-to-date. The form should be filled in all its parts and sent to the above address or you can communicate the application also via Technical Bulletin Application Communication Section placed in Leonardo AW Customer Portal - MyCommunications Area. We thank you beforehand for the information given.				