SERVICE BULLETIN
OPTIONAL**N° 139-581****DATE:** March 25, 2021**REV. :** A - February 1, 2024

TITLE**ATA 21 - VENTILATION INSULATION IMPROVEMENT****REVISION LOG**

Helicopters already compliant with previous issues of this Service Bulletin do not need any additional action.

Revision A of this Service Bulletin extends the document effectivity to S/N 32006 and updates the document to the latest standard.

Revision bars identify changes.

1. PLANNING INFORMATION

A. EFFECTIVITY

AW139 helicopters S/N 31764, S/N 31766, S/N 31781, S/N 31782, S/N 31791, S/N 31796, S/N 31816, S/N 31820, S/N 31824, S/N 31830, S/N 31831 and S/N 32006.

B. COMPLIANCE

At Customer's option.

C. CONCURRENT REQUIREMENTS

N.A.

D. REASON

This Service Bulletin is issued in order to provide the necessary instructions on how to perform the installation of ventilation improvement insulation P/N 3G2140P00811.

LH issued this SB for the following reason:

Helicopter Reliability/Maintainability	
Product Improvement	
Obsolescence	
Customization	✓
Product/Capability Enhancement	

E. DESCRIPTION

This Service Bulletin has been developed to improve the insulation of the ventilation system. According to dedicated design the following components have been replaced:

- air ventilation manifold;
- cabin flexible and rigid ducts;
- cockpit diffusers and vents.

F. APPROVAL

The technical content of this Service Bulletin is approved under the authority of DOA nr. EASA.21.J.005. For helicopters registered under other Aviation Authorities, before applying the Service Bulletin, applicable Aviation Authority approval must be checked within Leonardo Helicopters customer portal.

EASA states mandatory compliance with inspections, modifications or technical directives and related time of compliance by means of relevant Airworthiness Directives.

If an aircraft listed in the effectivity embodies a modification or repair not LH certified and affecting the content of this Service Bulletin, it is responsibility of the Owner/Operator to obtain a formal approval by Aviation Authority having jurisdiction on the aircraft, for any adaptation necessary before incorporation of the present Service Bulletin.

G. MANPOWER

To comply with this Service Bulletin, approximately twelve (12) MMH are deemed necessary.

MMH are based on hands-on time and can change with helicopter configuration, personnel and facilities available. MMH are not comprehensive of the overall hours necessary to get access to work areas and to remove all the equipment that interferes with the application of the prescribed instructions.

H. WEIGHT AND BALANCE

WEIGHT (kg)	ARM (mm)	MOMENT (kg-mm)
		1.25
LONGITUDINAL BALANCE	4600	5750
LATERAL BALANCE	0	0

I. REFERENCES

I.1 PUBLICATIONS

Following Data Modules refer to AMP:

<u>DATA MODULE</u>	<u>DESCRIPTION</u>	<u>PART</u>
DM01 39-A-00-20-00-00A-120A-A	Helicopter on ground for a safe maintenance.	-
DM02 39-A-71-11-07-00A-520A-A	Forward sliding fairing - Remove procedure	-
DM03 39-A-71-11-07-00A-720A-A	Forward sliding fairing - Install procedure	-
DM04 39-A-06-41-00-00A-010A-A	Access doors and panels - General data	-
DM05 39-B-31-11-02-00A-520A-A	Top cover - Remove procedure	-
DM06 39-B-31-11-02-00A-720A-A	Top cover - Install procedure	-
DM07 39-A-21-20-06-00A-520A-A	Top left instrument panel air valve - Remove procedure	-

<u>DATA MODULE</u>	<u>DESCRIPTION</u>	<u>PART</u>
DM08 39-A-21-20-06-00A-720A-A	Top left instrument panel air valve - Install procedure	-
DM09 39-A-21-20-07-00A-520A-A	Bottom left instrument panel air valve - Remove procedure	-
DM10 39-A-21-20-07-00A-720A-A	Bottom left instrument panel air valve - Install procedure	-
DM11 39-A-21-20-00-00A-320A-A	Ventilation system - Operation test	-

I.2 ACRONYMS & ABBREVIATIONS

AMD	Aircraft Material Data Information
AMP	Aircraft Maintenance Publication
AR	As Required
DM	Data Module
DOA	Design Organization Approval
EASA	European Union Aviation Safety Agency
IPD	Illustrated Parts Data Publication
ITEP	Illustrated Tools and Equipment Publication
LH	Left Hand
MMH	Maintenance Man Hours
N.A.	Not Applicable
P/N	Part Number
RH	Right Hand
SB	Service Bulletin
S/N	Serial Number

I.3 ANNEX

N.A.

J. PUBLICATIONS AFFECTED

N.A.

K. SOFTWARE ACCOMPLISHMENT SUMMARY

N.A.

2. MATERIAL INFORMATION

A. REQUIRED MATERIALS

A.1 PARTS

#	P/N	ALTERNATIVE P/N	DESCRIPTION	Q.TY	LVL	NOTE	LOG P/N
1	3G2140P00811		VENTILATION IMPROVEMENT INSULATION	REF	.		-
2	AA0518A-000		Diffuser	1	..		139-581L1
3	AA0519A-000		Diffuser	1	..		139-581L1
4	AA0725A-000		Manifold	1	..		139-581L1
5	AA0726A-000		Air vent duct assy RH	1	..		139-581L1
6	AA0727A-000		Air vent duct assy LH	1	..		139-581L1
7	AA0728A-000		Flex duct	2	..		139-581L1
8	AA0729A-000		Flex duct	2	..		139-581L1
9	AA0730A-000		Flex duct	2	..		139-581L1
10	AA0731A-000		Air vent duct assy	2	..		139-581L1
11	AA0950A-000		Air vent	12	..		139-581L1
12	AA0951A-000		Air vent	4	..		139-581L1
13	AW001CK06HS		Strap, tiedown	20	..		139-581L1
14	AW001CL003CT-X1		Support, electrical cable	2	..		139-581L1

Refer also to IPD for the spares materials required to comply with the AMP DMs referenced in the accomplishment instructions.

A.2 CONSUMABLES

The following consumable materials, or equivalent, are necessary to accomplish this Service Bulletin:

#	SPEC./LH CODE NUMBER	DESCRIPTION	Q.TY	NOTE	PART
15	AWMS05-001, TY I, CL B, GR 2	Sealant MC-780 B(C355)	AR	(1)	-
16	199-05-002, TY I, CL 2.	Adhesive EA 9309.3NA (C021)	AR	(1)	-
17	199-05-002, TYPE II, CLASS 3.	Adhesive EA 956NA(C193)	AR	(1)	-
18	199-05-152, TYPE I, CL 2.	Clear adhesive RTV732(C126)	AR	(1)	-
19	Commercial	Loctite 406 (C449)	AR	(1)	-

Refer also to AMDI for the consumable materials required to comply with the AMP DMs referenced in the accomplishment instructions.

A.3 LOGISTIC MATRIX

In order to apply this Service Bulletin, the following Logistic P/N can be ordered in accordance with the applicable notes:

LOGISTIC P/N	Q.TY (PER HELO)	NOTE	PART
139-581L1	1		-

NOTES

(1) To be procured as local supply.

B. SPECIAL TOOLS

Refer to ITEP for the special tools required to comply with the AMP DMs referenced in the accomplishment instructions.

SPECIAL TOOLS NOTES

N.A.

C. INDUSTRY SUPPORT INFORMATION

Customization.

3. ACCOMPLISHMENT INSTRUCTIONS

GENERAL NOTES

- a) Place an identification tag on all components that are re-usable, including the attaching hardware that has been removed to gain access to the modification area and adequately protect them until their later re-use.
 - b) Let adhesive cure at room temperature for at least 24 hours unless otherwise specified.
 - c) All lengths are in mm.
1. In accordance with DM 39-A-00-20-00-00A-120A-A, prepare the helicopter on ground for a safe maintenance. Disconnect the battery, all electrical power sources and/or the external power supply.
 2. With reference to Figure 1 thru Figure 5, gain access to the area affected by the installation and perform ventilation improvement insulation P/N 3G2140P00811 as described in the following procedure:
 - 2.1 In accordance to AMP DM 39-A-71-11-07-00A-520A-A remove forward sliding fairing 473AL.
 - 2.2 In accordance to AMP DM 39-A-06-41-00-00A-010A-A remove access panel 150CT and 150AT.
 - 2.3 With reference to Figure 3 Detail E, remove the n°2 water drain lines and keep the existing fasteners for the next reinstallation.
 - 2.4 With reference to Figure 2, RH side, remove manifold P/N 3G2141P00351, strap P/N AW001CK06CH, n°4 bolts P/N AN3C4A, n°4 washers P/N NAS1149C0332R, n°4 washers P/N NAS1149C0363R. Keep the hardware for the next reinstallation.

NOTE

- With reference to next Step in place of flex duct P/N BWT121160240A flex duct P/N 9911B010000 may have been installed.
- 2.5 With reference to Figure 2, remove flex duct P/N BWT121160240A, n°2 strap P/N MS3367-6-0.

NOTE

With reference to next Step in place of flex duct P/N BWT121160152A, flex duct P/N 9913B010000 may have been installed.

- 2.6 With reference to Figure 2, remove flex duct P/N BWT121160152A, n°2 strap P/N MS3367-6-0.
- 2.7 With reference to Figure 2, remove flex duct P/N BWT121160341A, n°2 strap P/N MS3367-6-0.
- 2.8 With reference to Figure 2 Section A-A, remove n°2 valves P/N 204-070-483-3, n°8 screws P/N AN525-10R10. Keep the hardware for the next reinstallation.
- 2.9 With reference to Figure 2, remove the n°1 ventilation rear cover P/N 5333A35951, n°5 screws MS27039-0804. Keep the n°1 cover and the hardware for the next reinstallation.
- 2.10 With reference to Figure 2, remove gasper duct assy P/N 3G21106P02331.
- 2.11 With reference to Figure 2 Section A-A, remove n°4 valves P/N 204-070-483-3, n°16 screws P/N AN525-10R10. Keep the hardware for the next reinstallation.
- 2.12 With reference to Figure 2, remove the n°1 ventilation rear cover P/N 5333A35851, n°5 screws MS27039-0804. Keep the n°1 cover and the hardware for the next reinstallation.
- 2.13 With reference to Figure 2, remove gasper duct assy P/N 3G21106P01431.

NOTE

With reference to next Step in place of flex duct P/N BWT121160240A flex duct P/N 9911B010000 may have been installed.

- 2.14 With reference to Figure 2, RH side, remove flex duct P/N BWT121160240A, n°2 strap P/N MS3367-6-0.

NOTE

With reference to next Step in place of flex duct P/N BWT121160152A, flex duct P/N 9913B010000 may have been installed.

- 2.15 With reference to Figure 2, remove flex duct P/N BWT121160152A, n°2 strap P/N MS3367-6-0.
- 2.16 With reference to Figure 2, remove flex duct P/N BWT121160341A, n°2 strap P/N MS3367-6-0.
- 2.17 With reference to Figure 2 Section A-A, remove n°2 valves P/N 204-070-483-3, n°8 screws P/N AN525-10R10. Keep the hardware for the next reinstallation.

- 2.18 With reference to Figure 2, remove the n°1 ventilation rear cover P/N 5333A35951, n°5 screws MS27039-0804. Keep the n°1 cover and the hardware for the next reinstallation.
- 2.19 With reference to Figure 2, remove gasper duct assy P/N 3G21106P02331.
- 2.20 With reference to Figure 2 Section A-A, remove n°4 valves P/N 204-070-483-3, n°16 screws P/N AN525-10R10. Keep the hardware for the next reinstallation.
- 2.21 With reference to Figure 2, remove the n°1 ventilation rear cover P/N 5333A35851, n°5 screws MS27039-0804. Keep the n°1 cover and the hardware for the next reinstallation.
- 2.22 With reference to Figure 2, remove gasper duct assy P/N 3G21106P01331.
- 2.23 With reference to Figure 3 and Figure 4 Detail F, install manifold P/N AA0725A-00 using existing hardware and one strap P/N AW001CK06HS.
- 2.24 With reference to Figure 3 Detail E, reinstall the n°2 water drain lines using existing fasteners.

NOTE

Seal all around the air vent duct assy perimeter with a fillet of sealant MC-780 B, as shown on Figure 4 Detail D.

- 2.25 With reference to Figure 3 on RH side, install flex duct P/NAA00729A-000 using N°2 strap P/N AW001CK06HS.
- 2.26 With reference to Figure 3 on RH side, install flex duct P/NAA00730A-000 using N°2 strap P/N AW001CK06HS.
- 2.27 With reference to Figure 3 Section C-C, install n°1 air vent duct assy RH P/N AA0726A-000, n°4 air vent P/N AA0950A-000 using existing screws.
- 2.28 Reinstall ventilation cover AFT P/N 3P5333A35851 using existing hardware.
- 2.29 With reference to Figure n°3 install on indicated position n°1 support P/N AW001CL003CT-X1 using adhesive P/N EA 956NA.
- 2.30 With reference to Figure 3 on RH side, install flex duct P/NAA00728A-000 using N°3 strap P/N AW001CK06HS.
- 2.31 With reference to Figure 3 install air vent duct assy P/N AA0731A-000, n°2 air vent AA0950A-000 using existing screws.
- 2.32 Reinstall ventilation cover rear P/N 3P5333A35951 using existing hardware.
- 2.33 With reference to Figure 3 on LH side, install flex duct P/NAA00729A-000 using N°2 strap P/N AW001CK06HS.
- 2.34 With reference to Figure 3 on LH side, install flex duct P/NAA00730A-000 using N°2 strap P/N AW001CK06HS.

- 2.35 With reference to Figure 3 Section C-C, install n°1 air vent duct assy LH P/N AA0727A-000, n°4 air vent P/N AA0950A-000 using existing screws.
- 2.36 Reinstall ventilation cover AFT P/N 3P5333A35851 using existing hardware.
- 2.37 With reference to Figure n°3 install on indicated position n°1 support P/N AW001CL003CT-X1 using adhesive P/N EA 956NA.
- 2.38 With reference to Figure 3 on LH side, install flex duct P/NAA00728A-000 using N°3 strap P/N AW001CK06HS.
- 2.39 With reference to Figure 3 install air vent duct assy P/N AA0731A-000, n°2 air vent AA0950A-000 using existing screws.
- 2.40 Reinstall ventilation cover rear P/N 3P5334A35951 using existing hardware.
- 2.41 In accordance to AMP DM 39-A-71-11-07-00A-720A-A install forward sliding fairing 473AL.
- 2.42 With reference to Figure 6 View K, remove diffuser P/N AA0506A-000 (RH side), one strap P/N MS3367-6-0.
- 2.43 With reference to Figure 6 View K, install diffuser P/N AA0519A-000 (RH side), one strap P/N AW001CK06HS.
- 2.44 With reference to Figure 5 View L, Figure 6 Section M-M, bond diffuser P/N AA0519A-000 on ventilation environmental outlet fairing assy RH P/N 3G5320A082333 using adhesive EA9303.3NA.
- 2.45 In accordance to AMP DM 39-B-31-11-02-00A-520A-A and with reference to Figure 5, remove the top cover to get access at n°4 air vents.
- 2.46 In accordance to applicable maintenance steps of AMP DM 39-A-21-20-06-00A-520A-A and with reference Figure 5 Detail G, remove top left air vent P/N AA0934A-000, strap P/N MS33677-6-0, n°2 screws P/N MS24694-54, n°2 washer P/N NAS1149DN816K, n°2 nuts P/N MS21042L08. Keep the hardware for the next reinstallation.
- 2.47 In accordance to applicable maintenance steps of AMP DM 39-A-21-20-06-00A-720A-A install top left air vent P/N AA0951A-000 using existing hardware. After the air vent assembly, apply 2 drops of Loctite 406 on the ventilation outlet in the 2 positions as shown on Figure 5 Detail J.
- 2.48 With reference to Figure 5 Section H-H, install cockpit Y shaped rigid duct on top left air vent P/N AA0951A-000 using adhesive RTV732 and strap P/N AW001CK06HS.
- 2.49 In accordance to applicable maintenance steps of AMP DM 39-A-21-20-07-00A-520A-A and with reference Figure 5 Detail G, remove bottom left air vent P/N AA0934A-000, strap P/N MS33677-6-0, n°2 screws P/N MS24694-54, n°2 washer P/N NAS1149DN816K, n°2 nuts P/N MS21042L08.

Keep the hardware for the next reinstallation.

- 2.50 In accordance to applicable maintenance steps of AMP DM 39-A-21-20-07-00A-720A-A install bottom left air vent P/N AA0951A-000 using existing hardware. After the air vent assembly, apply 2 drops of Loctite 406 on the ventilation outlet in the 2 positions as shown on Figure 5 Detail J.
- 2.51 With reference to Figure 5 Section H-H, install cockpit Y shaped rigid duct on left bottom air vent P/N AA0951A-000 using adhesive RTV732 and strap P/N AW001CK06HS.
- 2.52 Repeat the Step 2.46 thru step 2.51 for the n°2 right side air vents installation.
- 2.53 In accordance to AMP DM 39-B-31-11-02-00A-720A-A and with reference to Figure 5, reinstall the top cover using same hardware.
3. In accordance to AMP DM 39-A-06-41-00-00A-010A-A reinstall access panel 150CT and 150AT using same hardware.
4. In accordance to AMP DM 39-A-71-11-07-00A-720A-A reinstall forward sliding fairing 473AL.
5. In accordance with AMP DM 39-A-21-20-00-00A-320A-A perform the Ventilation system Operation test.
6. In accordance with weight and balance changes, update the Chart A (see Rotorcraft Flight Manual, Part II, section 6).
7. Return the helicopter to flight configuration and record for compliance with this Service Bulletin on the helicopter logbook.
8. Gain access to My Communications section on Leonardo WebPortal and compile the "Service Bulletin Application Communication".

As an alternative, send the attached compliance form to the following mail box:

engineering.support.lhd@leonardo.com

and (for North, Central and South America) also to:

AWPC.Engineering.Support@leonardocompany.us

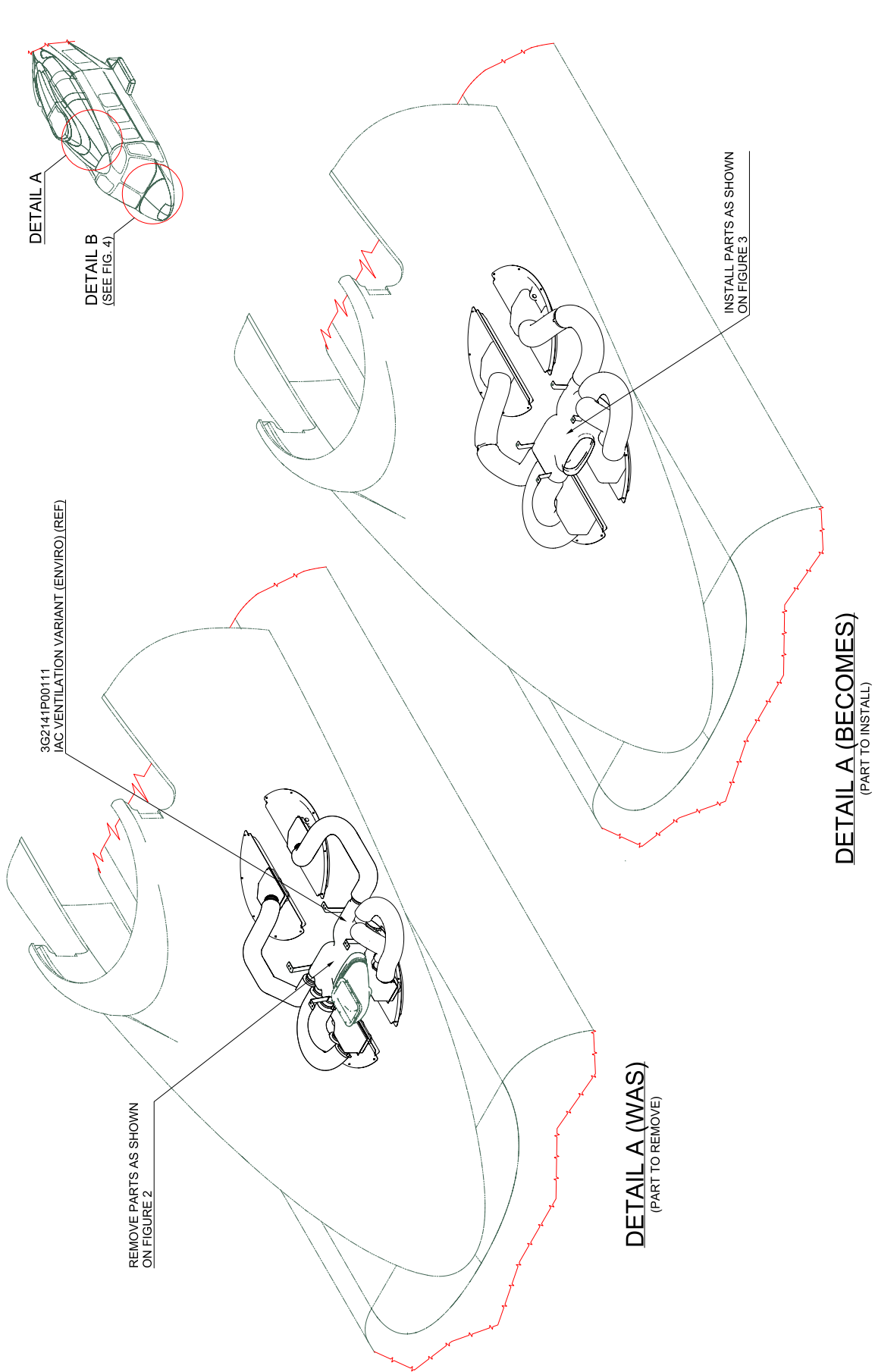

3G2140P00811
VENTILATION IMPROVEMENT INSULATION RETRO-MODIFICATION

Figure 1

SEAL WITH:
MC-780 B SEALANT
(ALL AROUND THE AIR VENT DUCT ASSY PERIMETER)

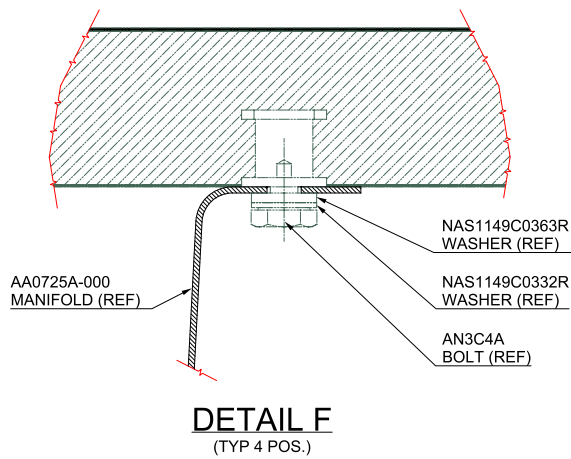
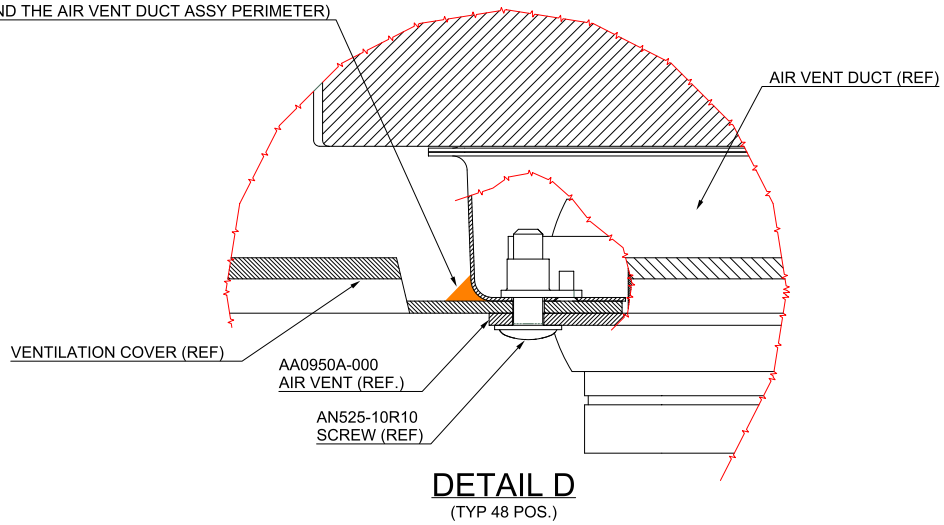

REMOVE AND INSTALL ON THE NEW MANIFOLD
(USING EXISTING FASTENERS)

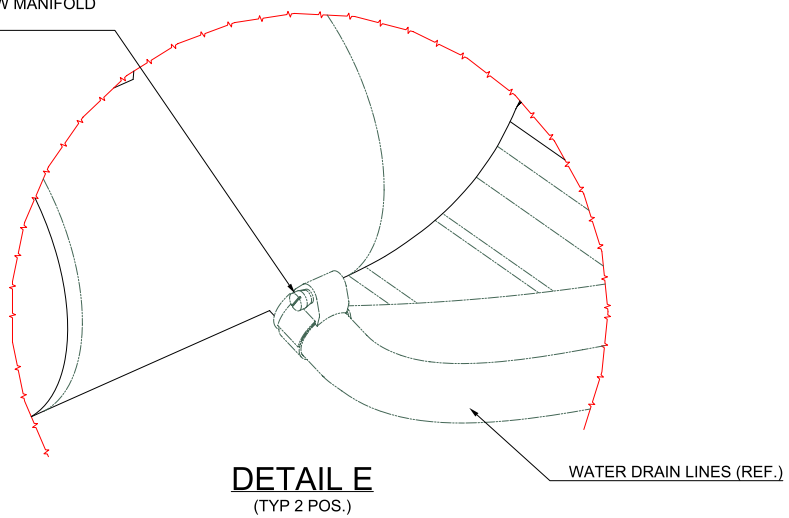
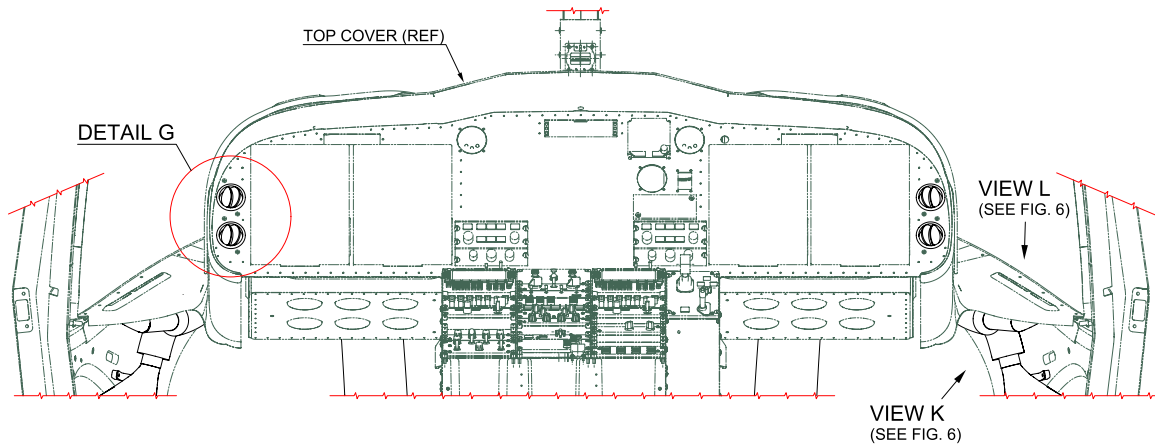
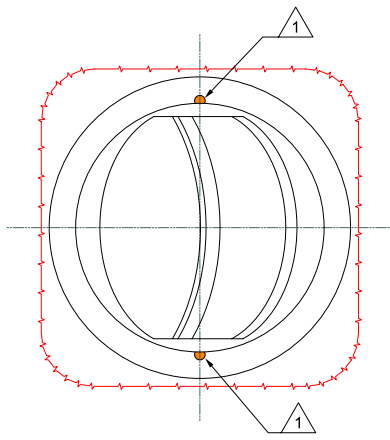

Figure 4



DETAIL B

(STRUCTURAL AND SYSTEMS ARE PARTIALLY OMITTED FOR BETTER CLARITY PURPOSE)



DETAIL J
(TYP 4 POS.)

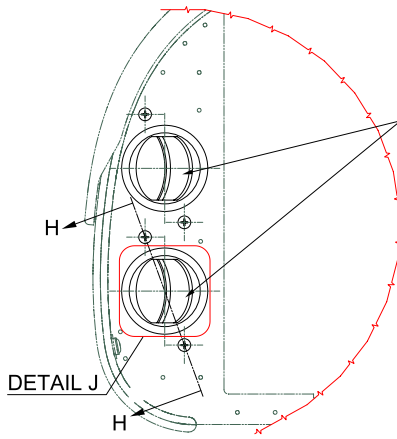

DETAIL J

(LH SIDE SHOWN, RH SIDE SYMMETRIC)

REMOVE:
AA0934A-000 AIR VENT (2 POS.)
MS24694-S4 SCREW (4 POS.)
NAS1149DN816K WASHER (4 POS.)
MS21042L08 NUT (4 POS.)
INSTALL:
AA0951A-000 AIR VENT (2 POS.)
MS24694-S4 SCREW (4 POS.)
NAS1149DN816K WASHER (4 POS.)
MS21042L08 NUT (4 POS.)
(REUSE EXISTING FASTENERS)

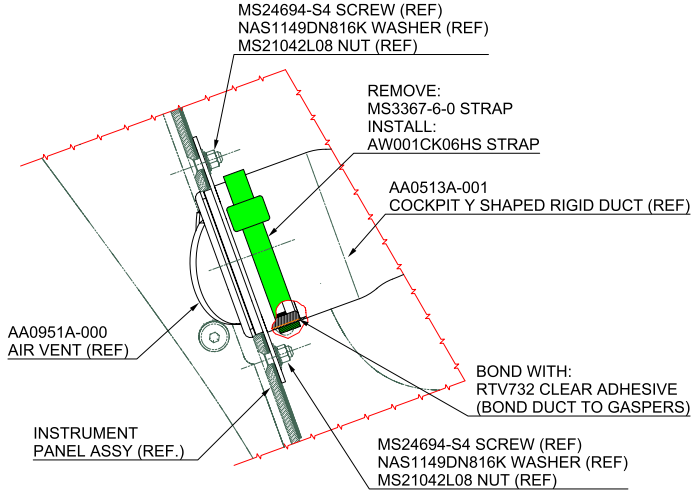

SECTION H-H
(TYP 4 POS.)

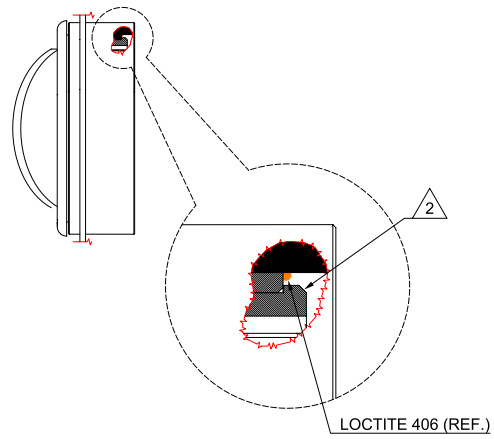

- 1 - AFTER THE AIR VENT ASSEMBLY, APPLY 2 DROPS OF LOCTITE 406 ON THE VENTILATION OUTLET IN THE 2 POSITIONS SHOWN ON "DETAIL J".
- 2 - DURING THE APPLICATION OF LOCTITE 406 BE CAREFUL TO NOT APPLY THE SEAL ON THIS PART.

Figure 5

S.B. N°139-581 OPTIONAL
DATE: March 25, 2021
REVISION: A - February 1, 2024

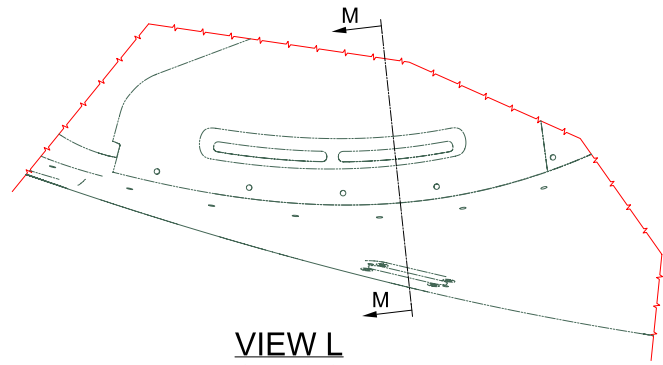

VIEW L
(REF. FIG. 5)
(LH SIDE SHOWN, RH SIDE SYMMETRIC)

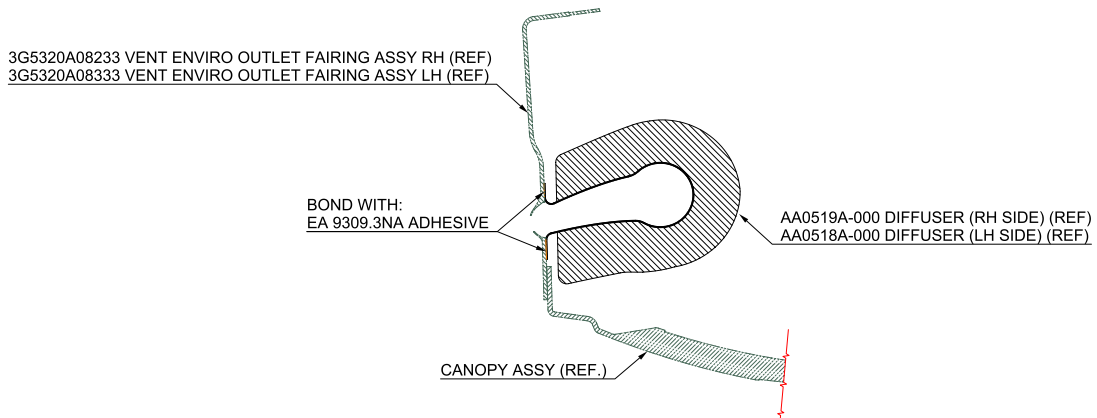

SECTION M-M
(RH SIDE SHOWN, LH SIDE SYMMETRIC)

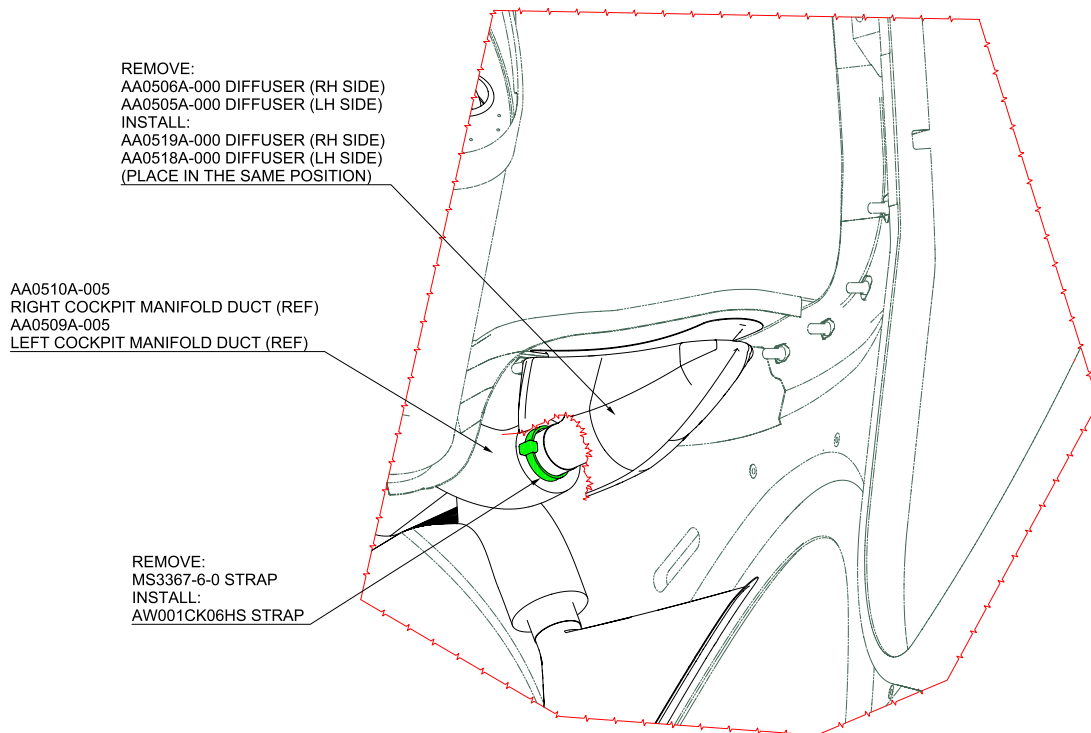

VIEW K
(REF. FIG. 5)
(LH SIDE SHOWN, RH SIDE SYMMETRIC)

Figure 6

