

SERVICE BULLETIN

TITLE: Extinguishing - Install of the Cockpit fire extinguisher without Halon

SB Type: Corrective measure

APPLICABILITY

Model:	EC155
Version:	B, B1
Helicopters PREMOD:	0726B30 and 0726B32
Helicopters POSTMOD:	0726B28

Helicopters having received MOD 0726B30 or 0726B32 are not concerned
Helicopters PRE MOD 0726B28 refer to Chapter 3

COMPLIANCE: RECOMMENDED

Airbus Helicopters recommends that you comply with this Service Bulletin

SUMMARY

The purpose of this Service Bulletin is to install in the cockpit a fire extinguisher that doesn't contain Halon to comply with the new regulations which will be applicable from 2026.

GENERAL EVALUATION

Evaluation table			
Perform once	YES	Accomplish recurring	NO

Export Control:

US Export Control - No US content. This Item does not contain any U.S. origin ITAR or EAR content.

FR Export Control - Not Listed. This Item is not listed against the EC regulations in the EU/FR.

GENERAL ILLUSTRATION

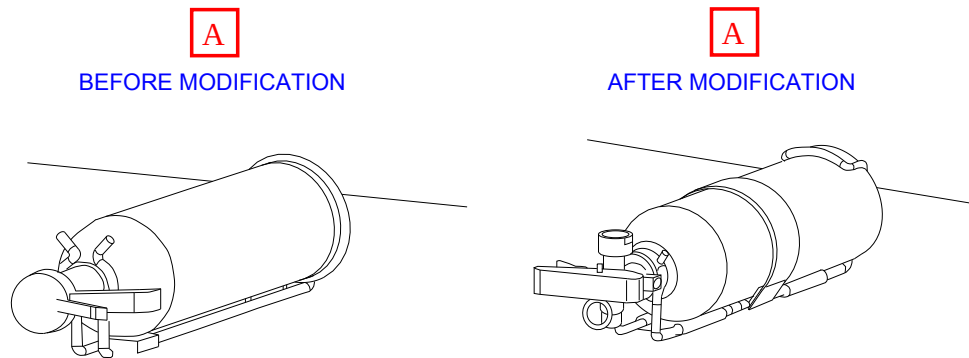

PLANNING INFORMATION

1. REASON

The purpose of this Service Bulletin is to install in the cockpit a fire extinguisher that doesn't contain Halon to comply with the new regulations which will be applicable from 2026. To do this, replace the HOTELIER cockpit extinguisher 12085-01 and its support 14561-00 with the new HAFEX UL extinguisher reference P3APP003010D and its new support P3APP003020J.

2. DESCRIPTION

This Service Bulletin provides instructions to :

- Remove the cockpit fire extinguisher and bracket (HOTELIER)
- Install the new cockpit fire extinguisher and bracket (HAFEX UL)

3. CONCURRENT REQUIREMENTS

For helicopters PRE MOD 0726B28, this SB can be applied but MOD 0726B28 also needs to be recorded on the helicopter documents for administrative purposes to ensure configuration follow-up.

4. APPROVAL

The technical content of this document is approved under the authority of the Design Organization Approval ref. EASA. 21J.700. For helicopters operated outside the terrain regulated by the EASA, the application of this document is subject to validation provided by the responsible aviation authority of the state of registry.

5. MANPOWER

NOTE

The Purpose of Man Hours is to give Airbus Helicopters customers a guideline for maintenance scheduling. It is not a contractual information.

Number of Persons	Qualification	Estimated Man Hours
1	Airframe technician	1h

6. Weight and balance

Weight (kg)	Lateral moment (kg.m) X	Longitudinal moment (kg.m) Y
+0.400kg	+0.27kg.m	+ 0.67 kg.m

7. ELECTRICAL LOAD DATA

Not applicable.

8. DOCUMENTATION AFFECTED

The changes to Instructions for Continued Airworthiness (ICA) which are required as a result of this SB will be incorporated in the next Normal Revision. Refer to DN.105.0014 until the information is available in the published technical documentation.

9. MATERIAL INFORMATION

9.1. Price

For information about the price of the modification kits and/or components, or for aid, contact the Airbus Helicopters Network Sales and Customer Relations Department.

9.2. Availability

Contact the Sales and Customer Relations Department to know the delivery lead times.

9.3. Procurement

Send an order for the necessary quantities to the Airbus Helicopters Network Sales and Customer Relations Department:

Airbus Helicopters
 Etablissement de Marignane
 Direction Ventes et Relations Client
 13725 MARIIGNANE CEDEX FRANCE

9.4. Mixability

You must not use the PRE MOD and POST MOD components together.

9.5. LIST OF NEW MATERIALS

Individual Spares List				
Item	Designation	Reference	MFC	QTY
1	HAND FIRE-EXTINGUISHER BOTTLE	P3APP003010D	F0210	1
2	HAND FIRE EXTINGUISHER BRACKET	P3APP003020J	F0210	1
3	SPACER	350A77-2428-20	F0210	2
4	WASHER	23116TK040X	F0210	2
5	SCREW SIX LOBE RECESS	ECS2365TK04S22X	F0210	2

Consumables, Materials and Expendables			
Designation	Reference	MFC	QTY
Locking compound	CM621	-	1

Special Tools				
Item	Designation	Reference	MFC	QTY
None				

9.6. LIST OF EXISTING PARTS

REMOVED SPARE PARTS	
Old Reference	Designation
12085-01	HAND FIRE-EXTINGUISHER BOTTLE
14561-00	HAND FIRE-EXTINGUISHER BRACKET

10. ACCOMPLISHMENT INSTRUCTION

Comply with the accomplishment procedure [26-25-0001, 933](#)

11. ADDITIONAL INFORMATION

Not applicable.

End of section

ACCOMPLISHMENT PROCEDURE 26-25-0001, 933

1. APPLICABILITY

Model:	EC155
Version:	B, B1
Helicopters PREMOD:	0726B34
Helicopters POSTMOD:	0726B28

2. GENERAL INFOS

Not applicable

3. PRELIMINARY REQUIREMENTS

3.1. Applicable Documents

- Helicopter parked in a repair shop - Safety instructions [MTC 20-07-02-201](#)
- ISO M and ISO MJ threads: General - Joining [MTC 20-02-05-101](#)
- Safeying assemblies: General - Safeying and locking assemblies [MTC 20-02-06-101](#)
- Use of cleaning products on individual parts and on aircraft - Cleaning [MTC 20-04-01-102](#)
- Helicopter parked in a repair shop - Safety instructions [MTC 20-07-02-201](#)
- Assembly by screws and nuts - Joining [MTC 20-02-05-404](#)
- Weighing of the cabin fire extinguisher POST 0726B32 [AMM 26-22-01-223](#)
- Removal / Installation - Fire extinguisher support POST 0726B28 [AMM 26-22-01-061](#)
- Clean and apply the close-up procedure to the work areas and the helicopter. [MTC 20-07-03-408](#)

3.2. Set up

- Park the helicopter in a hangar, refer to Helicopter parked in a repair shop - Safety instructions [MTC 20-07-02-201](#)
- Install appropriate means of access
- Disconnect all power sources
- Remove all the equipment and fittings necessary for good accessibility to the work area

3.3. Special tools

None

3.4. Materials

Designation	Reference	MFC	QTY
Locking compound	CM 621	-	1

3.5. Spares

Designation	Reference	MFC	QTY
HAND FIRE-EXTINGUISHER BOTTLE	P3APP003010D	F0210	1
HAND FIRE EXTINGUISHER BRACKET	P3APP003020J	F0210	1
SPACER	350A77-2428-20	F0210	2
Washer	23116TK040X	F0210	2
SCREW SIX LOBE RECESS	ECS2365TK04S22X	F0210	2

3.6. Safety conditions

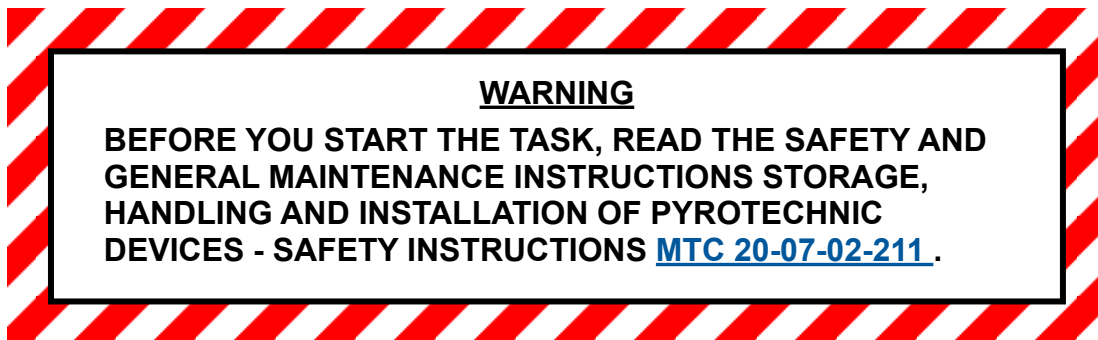

4. PROCEDURE

- 4.1. Removal of the Cockpit fire extinguisher and the bracket on Cockpit floor ([Figure 1](#)).
 - 4.1.1. Remove the Cockpit fire extinguisher (9) and the bracket (8), refer to Removal / Installation - Fire extinguisher support POST 0726B28 [AMM 26-22-01-061](#).
 - 4.1.2. Scrap the Cockpit fire extinguisher, bracket, washers (4) and screws ECS2365TK04S12X (6)
- 4.2. Installation of fire extinguisher on Cockpit floor configuration
 - 4.2.1. Install the HAND FIRE EXTINGUISHER BRACKET P3APP003020J (2) ([Figure 1](#)) with:
 - SCREW SIX LOBE RECESS ECS2365TK04S22X (5).
 - Locking compound CM 621.
 - Washer 23116TK040X (4).
 - SPACER 350A77-2428-20 (3).
 - 4.2.2. Weigh the HAND FIRE-EXTINGUISHER BOTTLE P3APP003010D (1) , refer to Weighing of the cabin fire extinguisher POST 0726B32 [AMM 26-22-01-223](#).
 - 4.2.3. Install the HAND FIRE-EXTINGUISHER BOTTLE P3APP003010D (1) on the HAND FIRE EXTINGUISHER BRACKET P3APP003020J (2) and close the attachment clamp of bracket.

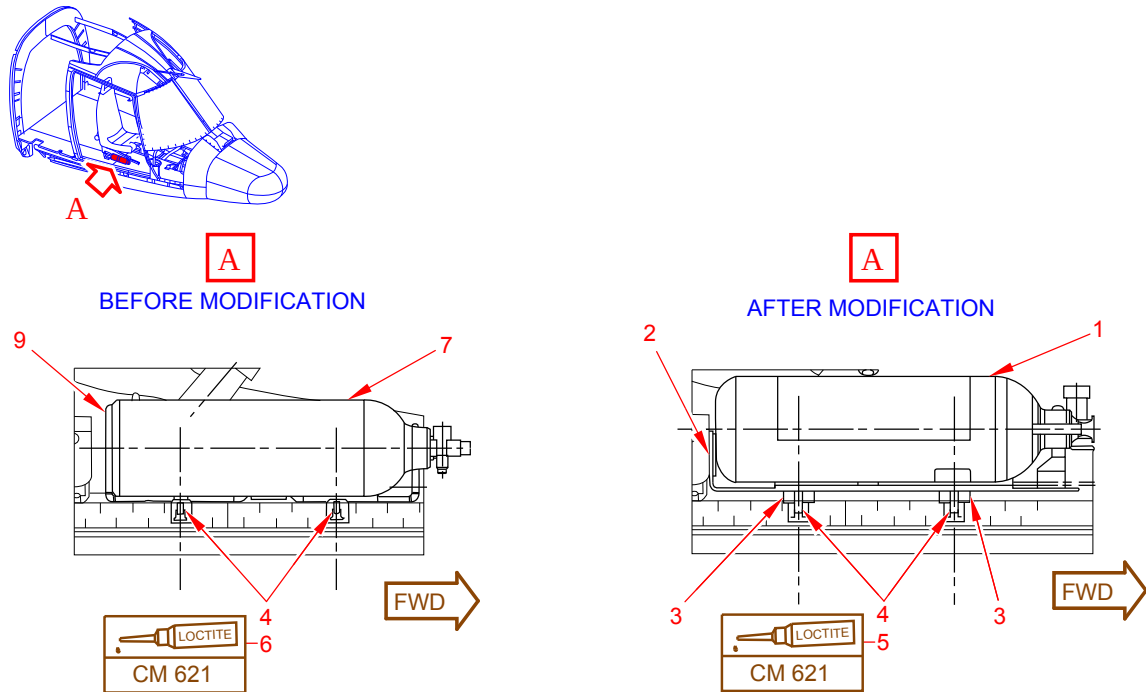

Figure 1

5. CLOSE UP

- 5.1. Clean and apply the close-up procedure to the work areas and the helicopter.
[MTC 20-07-03-408](#)
- 5.2. After you complete the work, record the new weight and moment in your applicable document.
- 5.3. For helicopters PRE MOD 0726B28, record compliance with MOD 0726B28 in the helicopter documents.
- 5.4. Record compliance with the MOD 0726B34 in the helicopter documents
- 5.5. Record compliance with this Service Bulletin (see IN 3785-I-00 for instructions):
QR code or hypertext link



[SB EC155-26-25-0001](#)

End of service bulletin