

## **ERRATA CORRIGE**

***Please find here attached the page that has to be replaced in the basic Service Bulletin n°189-295 Rev. /.***

- **PAGE 14 “Figure 3”**

The description of the bottom picture “VIEW D – INCORRECT ASSEMBLY PRACTICE” has been changed.

***Was:***

“GLIDE SLOPE ANTENNA P/N 6208-88-62, ANTENNA CORRECTLY MOUNTED, PRESENCE OF SEALANT IS NOT FOUND”

***Becomes:***

“GLIDE SLOPE ANTENNA P/N 6208-88-62, ANTENNA INCORRECTLY MOUNTED, PRESENCE OF SEALANT IS FOUND”

---

---

**SERVICE BULLETIN**

**N° 189-295**

**ALERT**

**DATE:** November 29, 2021

**REV. :** /

---

---

**TITLE**

**ATA 34 – GLIDE SLOPE ANTENNA INSPECTION**

**REVISION LOG**

First Issue

---

An appropriate entry should be made in the aircraft log book upon accomplishment.  
If ownership of aircraft has changed, please, forward to new owner.

---

## **1. PLANNING INFORMATION**

### **A. EFFECTIVITY**

#### **Part I**

- ✓ All AW189 helicopters from S/N 92001 to S/N 92010 equipped with Glide Slope Antenna P/N 6208-88-62 as part of the Kit Glide Slope Antenna P/N 8G3430F00111.
- ✓ All Glide Slope Antennas P/N 6208-88-62, previously installed on the helicopter, kept in stock.

#### **Part II**

All AW189 helicopters from S/N 92001 to S/N 92010 equipped with Glide Slope Antenna P/N 6208-88-62 for which the acceptance test procedure prescribed in Part I succeeded, but evidence of sealant was still found after the cleaning procedure.

### **B. COMPLIANCE**

#### **Part I**

- ✓ Within 200 FH or 6 months, whichever occurs first after the issue of this Service Bulletin.
- ✓ Before next installation on any helicopter, or within 6 months, whichever occurs first after the issue of this Service Bulletin, for any Glide Slope Antenna P/N 6208-88-62 previously installed on any helicopter and kept in stock.

#### **Part II**

After 1 year from compliance with Part I.

### **C. CONCURRENT REQUIREMENTS**

N.A.

### **D. REASON**

This Service Bulletin is issued in order to prescribe a visual inspection of the Glide Slope Antenna P/N 6208-88-62, part of the kit Glide Slope Antenna P/N 8G3430F00111, a corrective action in case the presence of sealant is found and its replacement if the antenna is not operational after the corrective action implementation.

### **E. DESCRIPTION**

During the troubleshooting after an unexpected helicopter behavior, the replacement of the Glide Slope Antenna solved the malfunction.

A deeper investigation performed by the antenna supplier concluded that the root cause of the event were the two coaxial connectors isolated from their ground plane by the presence of grey mastic.

The design, production and maintenance drawing and instructions did not request any sealant application in this location. As a consequence, LHD decided to issue this SB to check if any other glide slope antenna has a similar sealant application around the connectors.

Part I of this Service Bulletin prescribes the necessary instruction on how to perform the visual inspection to check presence of sealant around the Glide Slope Antenna P/N 6208-88-62. In case of presence of sealant, this SB gives instructions on how to remove the sealant from affected areas, and perform an acceptance test procedure. In case of failure of the acceptance test, this SB gives the instruction of the replacement of the Glide Slope Antenna P/N 6208-88-62 and the n° 2 connectors P/N PE4958 that have been found not operational.

Part II of this Service Bulletin prescribes instructions for the replacement of the Glide Slope Antenna P/N 6208-88-62 and/or the connectors P/N PE4958 that have been found with persistent presence of sealant after Part I, even in case the antenna passed the applicable functional test after cleaning.

## **F. APPROVAL**

The technical content of this Service Bulletin is approved under the authority of DOA nr. EASA.21.J.005. For helicopters registered under other Aviation Authorities, before applying the Service Bulletin, applicable Aviation Authority approval must be checked within Leonardo Helicopters customer portal.

EASA states mandatory compliance with inspections, modifications or technical directives and related time of compliance by means of relevant Airworthiness Directives. If an aircraft listed in the effectivity embodies a modification or repair not LHD certified and affecting the content of this Service Bulletin, it is responsibility of the Owner/Operator to obtain a formal approval by Aviation Authority having jurisdiction on the aircraft, for any adaptation necessary before incorporation of the present Service Bulletin.

## **G. MANPOWER**

To comply with this Service Bulletin, the following MMH are deemed necessary.

Part I: approximately five (5) MMH;

Part II: approximately three (3) MMH;

MMH are based on hands-on time and can change with personnel and facilities available.

## H. WEIGHT AND BALANCE

N.A.

## I. REFERENCES

### 1) PUBLICATIONS

Following Data Modules refer to AMP:

<u>DATA MODULE</u>	<u>DESCRIPTION</u>	<u>PART</u>
DM01 89-A-00-20-00-00A-120A-A	Helicopter on ground for a safe maintenance.	I, II
DM02 89-A-06-41-00-00A-010A-A	Access doors and panels – General data	I, II
DM03 89-A-34-32-01-00A-520A-A	Glide slope antenna – Remove procedure	I, II
DM04 89-A-34-32-01-00A-720A-A	Glide slope antenna – Install procedure	I, II
DM05 89-A-11-00-01-00A-720A-A	Decal – Install procedure	I, II

### 2) ACRONYMS & ABBREVIATIONS

AMP	Aircraft Maintenance Publication
DM	Data Module
DOA	Design Organization Approval
EASA	European Aviation Safety Agency
FH	Flight Hours
ITEP	Illustrated Tool and Equipment Publication
LHD	Leonardo Helicopters Division
MMH	Maintenance Man Hours
P/N	Part Number
SB	Service Bulletin
S/N	Serial Number

### 3) ANNEX

Annex A	AW189 External Glide Slope Antenna Kit Acceptance Test Procedure
Annex B	SB Application Form – Inspection report

**J. PUBLICATIONS AFFECTED**

N.A.

**K. SOFTWARE ACCOMPLISHMENT SUMMARY**

N.A.

## 2. MATERIAL INFORMATION

### A. REQUIRED MATERIALS

#### 1) PARTS

#	P/N	ALTERNATIVE P/N	DESCRIPTION	Q.TY	LVL	NOTE	LOG P/N
1	8G3430F00111		KIT GLIDE SLOPE ANTENNA	REF	.	-	-
2	8G3430A00311		GLIDE SLOPE EQUIPMENT INSTALLATION	REF	..	-	-
3	6208-88-62		Glide Slope Antenna	1	...	(1)(2)	-
4	ED300E7		Decal	1	...	(1)(2)	-
5	MS24693-C278		Screw	6	...	(1)(2)	-
6	PE4958		Coaxial Connector	AR	..	(1)(2)	-

#### 2) CONSUMABLES

The following consumable materials, or equivalent, are necessary to accomplish this Service Bulletin:

#	SPEC./LHD CODE NUMBER	DESCRIPTION	Q.TY	NOTE	PART
7	TT-I-735, Grade A	Isopropyl alcohol (C039)	AR	(3)	I
8	Commercial	Soft lint-free cloth (C011)	AR	(3)	I

Refer also to AMDI for the consumable materials required to comply with the AMP DM referenced in the accomplishment instructions.

#### 3) LOGISTIC MATRIX

N.A.

#### NOTE

- (1) Refer to "Industry Support Information" section before ordering this item.
- (2) Item to be ordered only if acceptance test procedure fails or presence of sealant is still found after cleaning procedure in Part I.
- (3) Item to be procured as local supply.

### B. SPECIAL TOOLS

The following special tool, or equivalent, is necessary to accomplish this Service Bulletin, in case the visual inspection identifies presence of sealant:

#	P/N	DESCRIPTION	Q.TY	NOTE	PART
9	-	Plastic scraper	1	-	I

Refer also to ITEP for the special tools required to comply with the AMP DM referenced in the accomplishment instructions.

## **C. INDUSTRY SUPPORT INFORMATION**

Owners/Operators who comply with the instructions of this Service Bulletin no later than the applicable date in the "Compliance" section will be eligible to receive "Required Materials" on free of charge basis.

Consumables, Special Tools, and materials required by AMP DM recalled in this SB are not included in the aforementioned policy.

NOTE: Customers who fail to comply with the instructions in this Service Bulletin before the compliance date are not eligible for the aforementioned special policy.

Please Issue relevant MMIR form to your Warranty Administration Dpt.

NOTE: Filling the form in ANNEX B with the evidence of incorrect assembly practice is mandatory; in case the MMIR is not accompanied by this document, it will be rejected.



### **3. ACCOMPLISHMENT INSTRUCTIONS**

#### **GENERAL NOTES**

- a) Place an identification tag on all components that are re-usable, including the attaching hardware that has been removed to gain access to the modification area and adequately protect them until their later re-use.
- b) Shape the cables in order to prevent interference with the structure and the other existing installations, using where necessary suitable lacing cords and plastic cable tiedown.

#### **PART I**

#### **NOTE**

Skip steps 1 thru 4 for Glide Slope Antennas  
P/N 6208-88-62 kept in stock.

1. In accordance with AMP DM 89-A-00-20-00-00A-120A-A, prepare the helicopter on ground for a safe maintenance. Disconnect the battery, all electrical power sources and/or the external power supply.
2. In accordance with AMP DM 89-A-06-41-00-00A-010A-A and with reference to Figure 1, gain access to the Glide Slope Antenna P/N 6208-88-62.
3. In accordance with AMP DM 89-A-34-32-01-00A-520A-A and with reference to Figure 1 Detail A, remove the Glide Slope Antenna P/N 6208-88-62. Keep the hardware for later reuse.
4. With reference to Figures 1 thru 3, perform a visual inspection looking for any evidence of sealant on the following components:
  - n°2 coaxial connectors P/N PE4958
  - Antenna Support Assy P/N 8G5315A30231.
5. With reference to Figures 1 thru 3, perform a visual inspection looking for any evidence of sealant around the connectors of the Glide Slope Antenna P/N 6208-88-62.
6. Record the inspection outcome on the report in ANNEX B and continue the procedure according to the following instructions:
  - 6.1 If presence of sealant is not found:

- 6.1.1 For Glide Slope Antennas P/N 6208-88-62 that were installed on the helicopter at the beginning of the accomplishment instructions go to step 7.
- 6.1.2 For Glide Slope Antennas P/N 6208-88-62 kept in stock go to step 13.
- 6.2 If presence of sealant is found, with reference to ANNEX B, record the presence of sealant in the SB application form and proceed with the following steps.

**CAUTION**

Pay particular attention not to damage any components during the sealant removal.

**CAUTION**

Pay attention not to remove the paint from the aluminium antenna support during the sealant removal.

- 6.3 With reference to Figures 1 thru 3, carefully remove the sealant on all affected components by means of a plastic scraper and a lint-free cloth (C011) moistened with isopropyl alcohol (C039).
- 6.4 After the sealant removal, check that the connector plating is not damaged and that no residue remains inside the RF connectors.

**NOTE**

If step 6.5.2 applies, the helicopter has to comply with Part II of this SB. Check the COMPLIANCE section for the applicable scheduling.

- 6.5 With reference to Figures 1 thru 3, perform again the inspection on n°2 coaxial connectors P/N PE4958 and on the Glide Slope Antenna P/N 6208-88-62.
  - 6.5.1 If presence of sealant is not found after cleaning, go to step 7.
  - 6.5.2 If presence of sealant is still found, either on the antenna or on the coaxial connector(s), even after cleaning, record the persistent presence of sealant in the report in ANNEX B.
- 7. In accordance with AMP DM 89-A-34-32-01-00A-720A-A and with reference to Figure 1 Detail A, install the Glide Slope Antenna P/N 6208-88-62 by means of existing hardware.
- 8. In accordance with ANNEX A, perform the External Glide Slope Antenna kit acceptance test procedure and record the test outcome in the report in ANNEX B.
  - 8.1 If the External Glide Slope Antenna kit acceptance test procedure succeeds, go to step 12.
  - 8.2 If the External Glide Slope Antenna kit acceptance test procedure fails replace both the Glide Slope Antenna P/N 6208-88-62 and n° 2 coaxial connectors P/N PE4958

according to the following steps.

9. In accordance with AMP DM 89-A-34-32-01-00A-520A-A and with reference to Figure 1 Detail A, remove the Glide Slope Antenna P/N 6208-88-62, and discard the existing hardware.
10. With reference to Figures 1 and 2, replace the Glide Slope Antenna P/N 6208-88-62 and n°2 coaxial connectors P/N PE4958 as follows:
  - 10.1 In accordance with AMP DM 89-A-34-32-01-00A-720A-A and with reference to Figure 1 Detail A, install the new Glide Slope Antenna P/N 6208-88-62 by means of n°6 screws P/N MS24693-C278.
  - 10.2 In accordance with AMP DM 89-A-11-00-01-00A-720A-A and with reference to Figure 1 Detail A, install the decal P/N ED300E7.
  - 10.3 With reference to Figure 1 replace the n°2 coaxial connectors P/N PE4958.
11. In accordance with ANNEX A, perform the External Glide Slope Antenna kit acceptance test procedure.
12. Return the helicopter to flight configuration and record for compliance with Part I of this Service Bulletin on the helicopter logbook.
13. Send the attached compliance form, report in ANNEX B and pictures to the following mail box:

[engineering.support.lhd@leonardocompany.com](mailto:engineering.support.lhd@leonardocompany.com)

As an alternative to filling the compliance form, gain access to My Communications section on Leonardo WebPortal and compile the "Service Bulletin Application Communication".

## **PART II**

1. In accordance with AMP DM 89-A-00-20-00-00A-120A-A, prepare the helicopter on ground for a safe maintenance. Disconnect the battery, all electrical power sources and/or the external power supply.
2. In accordance with AMP DM 89-A-34-32-01-00A-520A-A and with reference to Figure 1 Detail A, remove the Glide Slope Antenna P/N 6208-88-62, and discard the existing hardware.
3. With reference to Figures 1 and 2, replace the Glide Slope Antenna P/N 6208-88-62 and/or coaxial connector P/N PE4958 as follows:
  - 3.1 In accordance with AMP DM 89-A-34-32-01-00A-720A-A and with reference to Figure 1 Detail A, install the new Glide Slope Antenna P/N 6208-88-62 by means of n°6 screws P/N MS24693-C278.
  - 3.2 In accordance with AMP DM 89-A-11-00-01-00A-720A-A and with reference to Figure 1 Detail A, install the decal P/N ED300E7.
  - 3.3 With reference to Figure 1 replace the coaxial connector P/N PE4958.
4. In accordance with ANNEX A, perform the External Glide Slope Antenna kit acceptance test procedure.
5. Return the helicopter to flight configuration and record for compliance with Part II of this Service Bulletin on the helicopter logbook.
6. Send the attached compliance form and report in ANNEX B to the following mail box:  
[engineering.support.lhd@leonardocompany.com](mailto:engineering.support.lhd@leonardocompany.com)

As an alternative to filling the compliance form, gain access to My Communications section on Leonardo WebPortal and compile the “Service Bulletin Application Communication”.

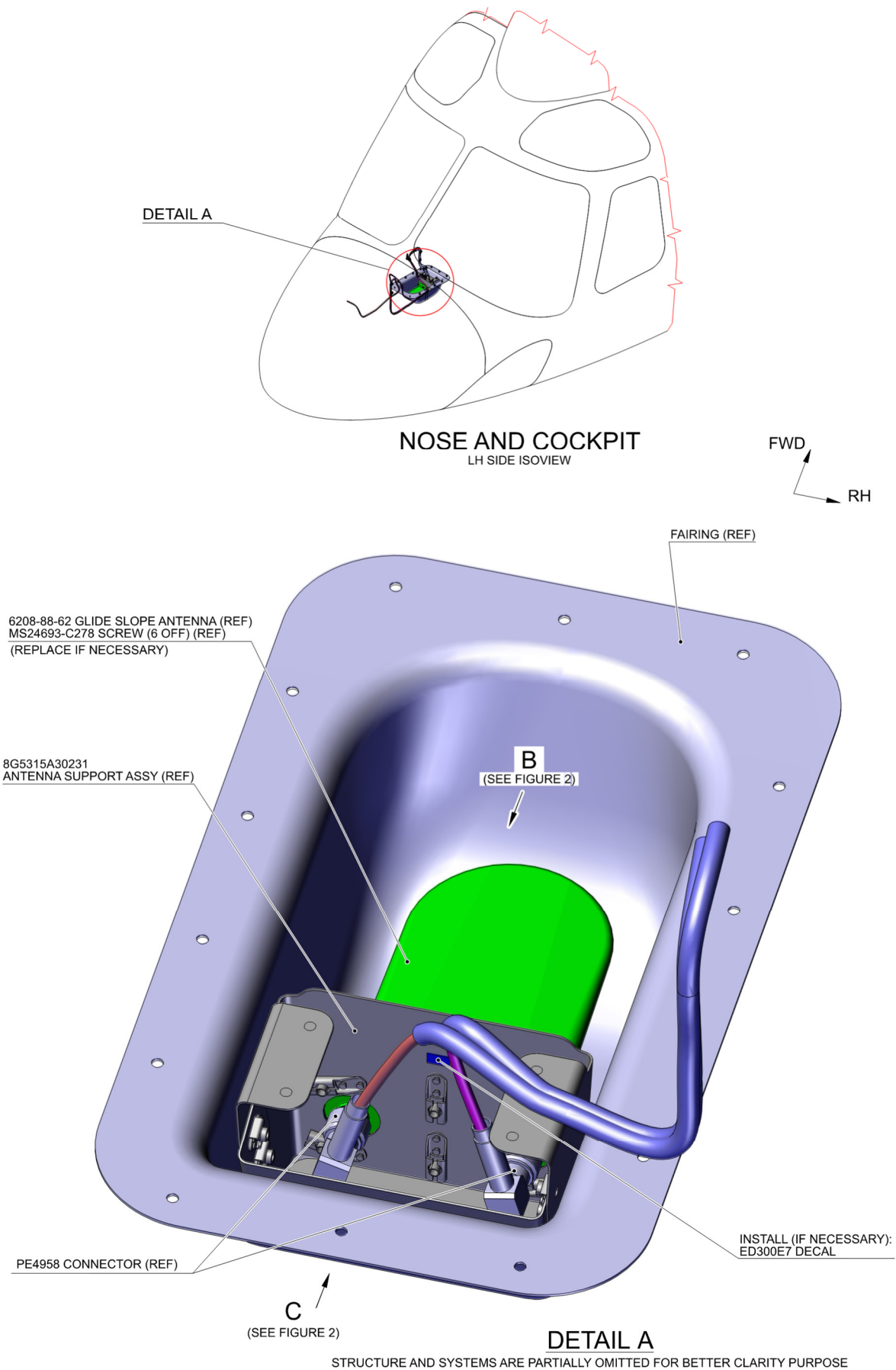

**Figure 1**

S.B. N°189-295 ALERT  
DATE: November 29, 2021  
REVISION: /

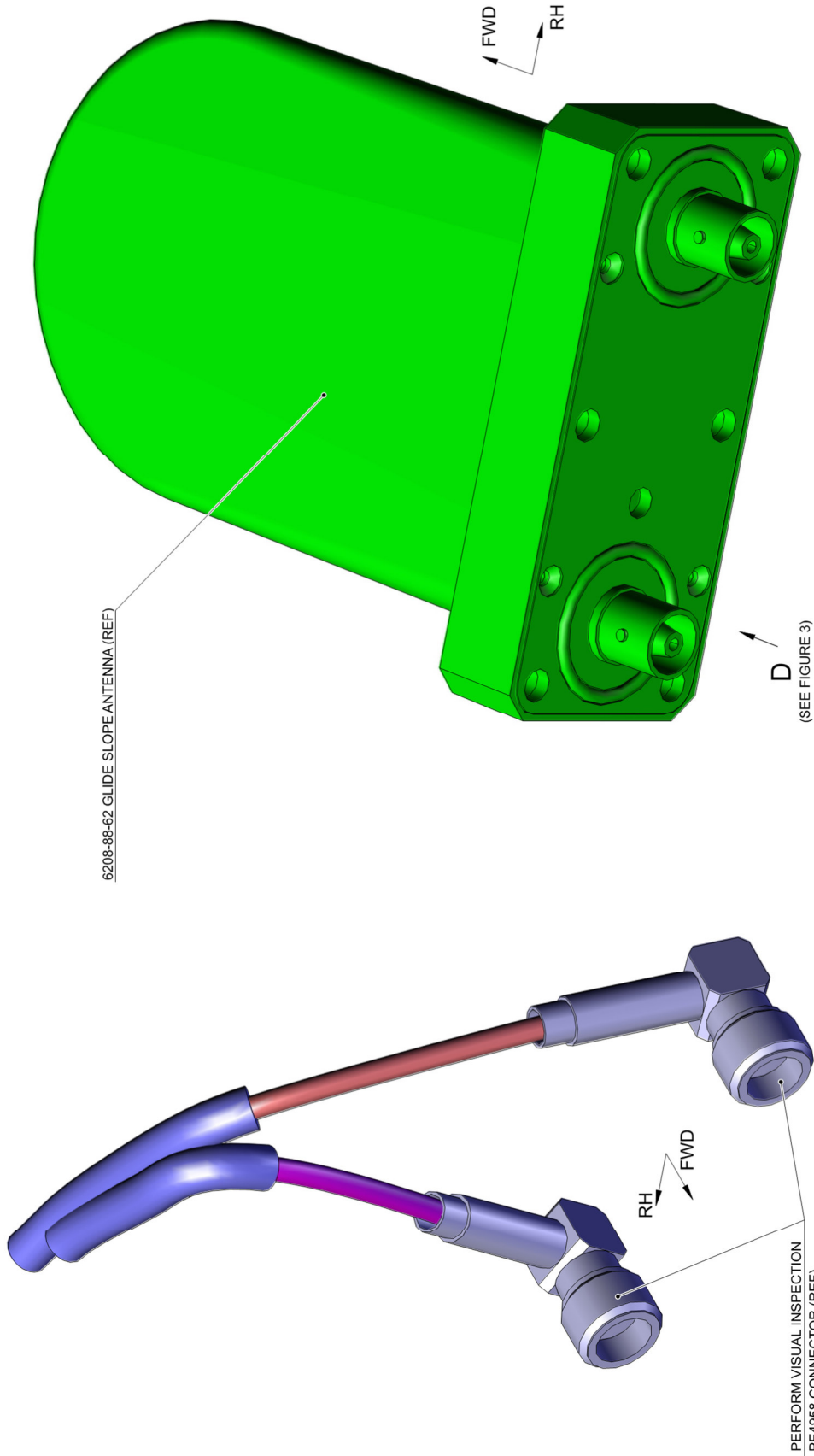

**VIEW C**

STRUCTURE AND SYSTEMS ARE PARTIALLY OMITTED FOR BETTER CLARITY PURPOSE  
(REFER TO FIGURE 1)

**VIEW B**

STRUCTURE AND SYSTEMS ARE PARTIALLY OMITTED FOR BETTER CLARITY PURPOSE  
(REFER TO FIGURE 1)

**Figure 2**

THE PICTURES ARE FOR REFERENCE PURPOSE ONLY



**VIEW D**  
**CORRECT ASSEMBLY PRACTICE**

GLIDE SLOPE ANTENNA P/N 6208-88-62. ANTENNA CORRECTLY MOUNTED, PRESENCE OF SEALANT IS NOT FOUND.  
(REFER TO FIGURE 2)

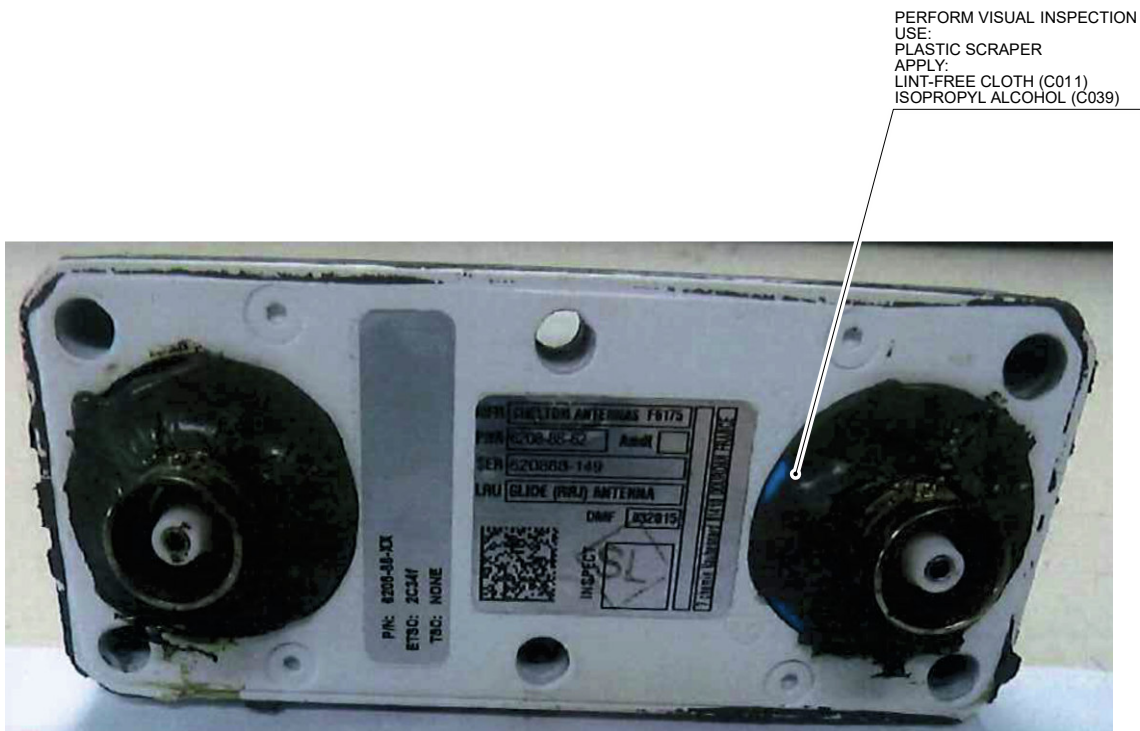

**VIEW D**  
**INCORRECT ASSEMBLY PRACTICE**

GLIDE SLOPE ANTENNA P/N 6208-88-62. ANTENNA INCORRECTLY MOUNTED, PRESENCE OF SEALANT IS FOUND.  
(REFER TO FIGURE 2)

**Figure 3**

S.B. N°189-295 ALERT  
DATE: November 29, 2021  
REVISION: /

# **ANNEX A**

## **AW189 EXTERNAL GLIDE SLOPE ANTENNA KIT ACCEPTANCE TEST PROCEDURE**



## TEST EQUIPMENT

- Radio Communication Tester, IFR-4000 or equivalent.

## NOTES

- **WHEN TESTING MRC1-GS1, VERIFY THE PROPER GS INDICATION ON COPILOT PFD.** The NAV1/ILS option shall be selected from the standby instrument display menu to activate the GS visualization.
- **WHEN TESTING MRC2-GS2, VERIFY THE PROPER GS INDICATION ON PILOT.** The NAV2/ILS option shall be selected from the standby instrument display menu to activate the GS visualization.

## TEST PROCEDURE

1. Place the ramp test set IFR-4000 close to the cabin:
  - Connect the telescoping antenna to the test set ANT Port;
  - Turn ON the ramp test set;
  - Select the GLIDESLOPE operational mode with the MODE Select Key;
  - Set the RF LVL to  $-15$  dBm;
  - Set the 90/150 Hz to "---";
  - Set GS DDM to Zero (Center);
2. Tune the NAV1 frequency to 108.10 MHz by mean the MCDU (or the same set up on the LOC FREQ of the Test Set). Select NAV1 source on both PFDs by mean the Display Controllers. Make sure that the frequency of 334.70 MHz is showed on the FREQ of the test set.
3. Verify the GS1 indication is correctly displayed (0 DOT of deviation) on both pilot and copilot PFDs (Failure flags out of view) and on the standby instrument display.
4. Set the GS DDM knob to the values listed in Table 1. Verify and note the results.

Table 1 GS1 Marker Deflection Simulation Values

<b>GS1 Marker Deflection</b>			
<b>KNOB POSITION</b>	<b>PFD / STBY ADI Displayed</b>	<b>Expected</b>	<b>PASS/FAIL</b>
0.091 DDM UP		52% UP (GS Marker displayed closely above the DOT 1)	
0.175 DDM UP		100 % UP (2 dots UP)	
0.400 DDM UP		RANGE END	
0.091 DDM DOWN		52% DOWN (GS Marker displayed closely below the DOT 1)	
0.175 DDM DOWN		100 % DOWN 2 dots DOWN	
0.400 DDM DOWN		RANGE END	

<b>GS1 Sensibility</b>		
<b>Ramp Tester Attenuation</b>	<b>Limit Value</b>	<b>PASS/FAIL</b>
Attenuation: _____ dBm	≤ -25dBm	

5. Slowly increase the attenuation of the RF LVL on the ramp test set (more negative dBm). Verify that the GS1 visualization is valid (no failure flags) at least until the set attenuation is equal to -25 dBm (note result in Table 1).
6. Set the RF LVL attenuation on the test set back to -15 dBm. Repeat the tests above (from point 1 to 5) for GS2 system and check the correct value on both PFDs and on standby instrument display. Note the results in the Table 2.
7. Set the test set to OFF.

Table 2 GS2 Marker Deflection Simulation Values

<b>GS2 Marker Deflection</b>			
<b>KNOB POSITION</b>	<b>PFD / STBY ADI Displayed</b>	<b>Expected</b>	<b>PASS/FAIL</b>
0.091 DDM UP		52% UP (GS Marker displayed closely above the DOT 1)	
0.175 DDM UP		100 % UP (2 dots UP)	
0.400 DDM UP		RANGE END	
0.091 DDM DOWN		52% DOWN (GS Marker displayed closely below the DOT 1)	
0.175 DDM DOWN		100 % DOWN 2 dots DOWN	
0.400 DDM DOWN		RANGE END	

<b>GS2 Sensibility</b>		
<b>Ramp Tester Attenuation</b>	<b>Limit Value</b>	<b>PASS/FAIL</b>
Attenuation: _____ dBm	≤ -25dBm	

# **ANNEX B**

## **SB APPLICATION FORM – INSPECTION REPORT**

<b><u>Inspection Report - SB 189-295</u></b>	
<b>Helicopter S/N</b> (if not applicable, write "in stock")	
<b>Part I Compliance Date</b>	
<b>FH</b>	
1. Specify whether the inspection prescribed in Part I identified the presence of sealant in the assembly:	
<input type="checkbox"/> Sealant was found during the visual inspection prescribed in Part I.	<input type="checkbox"/> Sealant was <u>not</u> found during the visual inspection prescribed in Part I.
2. If evidence of sealant was found during the inspection, specify the components affected by the finding:	
<input type="checkbox"/> Glide Slope Antenna P/N 6208-88-62	
<input type="checkbox"/> Connector(s) P/N PE4958	
<input type="checkbox"/> Antenna Support Assy P/N 8G5315A30231	
<i>Please, also attach picture(s) of the item(s) affected by the presence of sealant.</i>	
3. If evidence of sealant was found, specify whether the sealant has been completely removed through the cleaning procedure:	
<input type="checkbox"/> Sealant was successfully removed.	<input type="checkbox"/> Sealant was <u>not</u> successfully removed.
4. If cleaning was not fully successful, specify the components presenting persistent presence of sealant:	
<input type="checkbox"/> Glide Slope Antenna P/N 6208-88-62	
<input type="checkbox"/> Connector(s) P/N PE4958	
<i>Please, also attach picture(s) of the item(s) affected by the persistent presence of sealant.</i>	
5. Specify whether the functional test prescribed in Part I has been successful:	
<input type="checkbox"/> Acceptance test procedure was successful.	<input type="checkbox"/> Acceptance test procedure was <u>not</u> successful.
<u>The following section should be compiled only if Compliance with Part II is required.</u>	
<b>Part II Compliance Date</b>	

Please send to the following address:  <b>LEONARDO S.p.A.</b> <b>CUSTOMER SUPPORT &amp; SERVICES - ITALY</b>  <b>PRODUCT SUPPORT ENGINEERING &amp; LICENSES DEPT.</b> Via Giovanni Agusta, 520 21017 Cascina Costa di Samarate (VA) - ITALY Tel.: +39 0331 225036 Fax: +39 0331 225988	<b>SERVICE BULLETIN COMPLIANCE FORM</b>	Date:
Number:		
Revision:		

Customer Name and Address:	Telephone:
	Fax:
	B.T. Compliance Date:

Helicopter Model	S/N	Total Number	Total Hours	T.S.O.

Remarks:

**Information:**

We request your cooperation in filling this form, in order to keep out statistical data relevant to aircraft configuration up-to-date. The form should be filled in all its parts and sent to the above address or you can communicate the application also via Technical Bulletin Application Communication Section placed in Leonardo AW Customer Portal - MyCommunications Area. We thank you beforehand for the information given.