

---

---

SERVICE BULLETIN

N° **109EP-179**

**ALERT**

DATE: July 21, 2022

REV. : A - August 24, 2023

---

---

**TITLE**

**ATA 53 - CENTRAL FUSELAGE FRAME ASSY AT STA 1815 INSPECTION AND REINFORCEMENT OF**

**REVISION LOG**

Revision A is issued in order to add Part II and Part III.

Revision bars identify changes.

---

An appropriate entry should be made in the aircraft log book upon accomplishment.  
If ownership of aircraft has changed, please, forward to new owner.

---

## **1. PLANNING INFORMATION**

### **A. EFFECTIVITY**

All the A109E helicopters from S/N 11675 included, and subsequent.

### **B. COMPLIANCE**

#### **NOTE**

The helicopter's posts that have been repaired in accordance with this Service Bulletin, shall be inspected in accordance with this Service Bulletin after they have accumulated more than 1000 FH or 3500 landings since repair.

#### **NOTE**

The helicopter's posts that have been reinforced in accordance with Part II (LH side) or Part III (RH side) of this Service Bulletin are no longer affected by the relevant inspection (ref. Part I).

Helicopter that have accumulated more than 1000FH or 3500 landings, whichever occurs first:

- **PART I:**  
Within and not later than 100FH from the issuance of this SB and every 100FH thereafter.
- **PART II AND PART III:**  
Within and not later than August 31, 2026.

Helicopter that have accumulated up to 1000FH or 3500 landings, whichever occurs first:

- **PART I:**  
Within and not later than upon the achievement of 1000FH or 3500 landings and every 100FH thereafter.
- **PART II AND PART III:**  
Within and not later than August 31, 2026.

### **C. CONCURRENT REQUIREMENTS**

N.A.

## **D. REASON**

This Service Bulletin is issued in order to provide the necessary instructions on how to perform an inspection to detect cracks in the center fuselage at the intersection of the lateral pylon (LH and RH side) with floor spar, and, the necessary instructions for reinforcing the area (LH and RH sides).

## **E. DESCRIPTION**

An occurrence of cracks has been found in the fuselage of the LH A109E helicopters at the intersection of the lateral pylon with the floor spar at the STA 1815, in both the LH and RH sides.

In Part I of this Service Bulletin are given the instruction to perform an inspection in the area affected by the possible cracks.

Revision A is issued to provide the instruction for LH side fuselage reinforcement (Part II) and for RH side fuselage reinforcement (Part III).

## **F. APPROVAL**

The technical content of this Service Bulletin is approved under the authority of DOA nr. EASA.21.J.005. For helicopters registered under other Aviation Authorities, before applying the Service Bulletin, applicable Aviation Authority approval must be checked with Local Aviation Authority.

EASA states mandatory compliance with inspections, modifications or technical directives and related time of compliance by means of relevant Airworthiness Directives. If an aircraft listed in the effectivity embodies a modification or repair not LHD certified and affecting the content of this Service Bulletin, it is responsibility of the Owner/Operator to obtain a formal approval by Aviation Authority having jurisdiction on the aircraft, for any adaptation necessary before incorporation of the present Service Bulletin.

## **G. MANPOWER**

To comply with this Service Bulletin the following MMH are deemed necessary:

Part I: approximately 6 (six) hours;

Part II: approximately 120 (one hundred and twenty) hours;

Part III: approximately 120 (one hundred and twenty) hours.

MMH are based on hands-on time and can change with personnel and facilities available.

## H. WEIGHT AND BALANCE

### PART I:

N.A.

### PART II

<b>WEIGHT (kg)</b>		0.43
<b>LONGITUDINAL BALANCE</b>	<b>ARM (mm)</b>	<b>MOMENT (kgmm)</b>
	1880	808

### PART III

<b>WEIGHT (kg)</b>		1.04
<b>LONGITUDINAL BALANCE</b>	<b>ARM (mm)</b>	<b>MOMENT (kgmm)</b>
	1880	1955

## I. REFERENCES

### I.1 PUBLICATIONS

<u>DATA MODULE</u>	<u>DESCRIPTION</u>	<u>PART</u>
DM01 00-10-4	Connection/disconnection of external electrical power	II, III
DM02 00-10-8	Connection/disconnection of external hydraulic power	II, III
DM03 00-20-1	Helicopter safety	All
DM04 06-40-1	Access panels and doors	II, III
DM05 07-30-1	Hoisting of complete helicopter	II, III
DM06 07-30-2	Hoisting of helicopter without main rotor	II, III
DM07 21-21-1	Air distribution system	II, III
DM08 25-11-9	Crew seats - removal/installation	II, III
DM09 25-21-12	Forward seat - removal/installation	II, III
DM10 25-81-7	Cockpit soundproofing panels - removal/installation	All
DM11 25-81-9	Passenger soundproofing panels - removal/installation	All
DM12 52-11-9	LH/RH cockpit doors - removal/installation	II, III
DM13 52-71-6	Operational test of cockpit/passenger compartment caution system	II, III
DM14 67-00-12	Control tube - general maintenance	II, III
DM15 67-11-1	Collective pitch control system	II
DM16 67-11-9	Collective pitch control lever - removal/installation	II

<u>DATA MODULE</u>	<u>DESCRIPTION</u>	<u>PART</u>
DM17 67-12-1	Cyclic pitch control system	III
DM18 67-11A-24	Collective pitch control adjustment procedure	II
DM19 67-00-26	Cyclic pitch control adjustment	III

## I.2 ACRONYMS

AR	As Required
DOA	Design Organization Approval
AMDI	Aircraft Material Data Information
MM	Maintenance Manual
DM	Data Module
FH	Flight Hours
EASA	European Aviation Safety Agency
LHD	Leonardo Helicopters Division
MMH	Maintenance Man Hours
N.A.	Not Applicable
PTUM	Pictorial Tools Usage Manual
P/N	Part Number
S/N	Serial Number

## I.3 ANNEX

N.A.

## J. PUBLICATIONS AFFECTED

Illustrated Parts Catalog S/N 11601 & subs

## K. SOFTWARE ACCOMPLISHMENT SUMMARY

N.A.

## 2. MATERIAL INFORMATION

### A. REQUIRED MATERIALS

#### A.1 PARTS

##### PART I

N.A.

##### PART II

#	P/N	ALTERNATIVE P/N	DESCRIPTION	Q.TY	LVL	NOTE	LOG P/N
<b>1</b>	<b>109G5330R01-301</b>		<b>LATERAL MOUNTING REINFORCEMENT LH</b>	<b>REF</b>	.		-
2	109-0329-72-229	109-0329-72-229M02	FWD cap LH	1	..	(1)	709-083L1
3	109G5307P39-113		Angle LH	1	..		709-083L1
4	109G5307P39-115		Left cap	1	..		709-083L1
5	109G5307P39-117		Doubler	1	..		709-083L1
6	109G5330A25-101		Stiffener Machined LH	1	..		709-083L1
7	109G5330R01-307		External butt-strap LH	1	..		709-083L1
8	109G5330R01-309		Internal butt-strap LH	1	..		709-083L1
9	109G5330R01-315		Web LH	REF	..	(2)	-
10	109G5330R01-317		Stiffener LH	1	..		709-083L1
11	A879A05L150		Rivet	10	..		709-083L1
12	CR2245-4-2		Rivet	10	..		709-083L1
13	CR2245-4-5		Rivet	10	..		709-083L1
14	CR2245-5-3		Rivet	10	..		709-083L1
15	MS20426AD3-5		Rivet	0.1kg	..		709-083L1
16	MS20426AD4-5		Rivet	0.1kg	..		709-083L1
17	MS20426AD5-5		Rivet	0.1kg	..		709-083L1
18	MS20470AD5-5		Rivet	0.1kg	..		709-083L1
19	MS20470E5-5		Rivet	0.1kg	..		709-083L1
20	MS21071L08		Nut Plate	1	..		709-083L1
21	NAS1739B4-3		Rivet	10	..		709-083L1
22	NAS9301B-4-02		Rivet	100	..		709-083L1
23	NAS9301B-4-03		Rivet	50	..		709-083L1
24	NAS9301B-5-03		Rivet	20	..		709-083L1
25	NAS9302B-4-02		Rivet	20	..		709-083L1
26	NAS9302B-5-04		Rivet	20	..		709-083L1
27	NAS9307M-4-02		Rivet	20	..		709-083L1
28	NAS9307M-4-03		Rivet	20	..		709-083L1
<b>29</b>	<b>109G5330R01-303</b>		<b>ANGLE REPAIR INSTALLATION LH</b>	<b>REF</b>	..		-
30	109G5330R01-305		Angle LH	REF	...	(3)	-
31	109G5330R01-311		Internal butt-strap LH	1	...		709-083L1
32	109G5330R01-313		Internal shim LH	1	...		709-083L1
33	MS20470AD5-5		Rivet	0.1kg	...		709-083L1
34	NAS9307M-4-03		Rivet	20	...		709-083L1
35	MS21069L3		Nut	8	.		709-083L1
36	MS20600AD4W3	CR2245-4-3	Rivet	24	.		709-083L1
37	MS20615M4-4		Rivet	0.1kg	.		709-083L1
38	MS20427M4-4		Rivet	0.1kg	.		709-083L1

S.B. N°109EP-179 ALERT

DATE: July 21, 2022

REVISION: A - August 24, 2023

### **PART III**

#	P/N	ALTERNATIVE P/N	DESCRIPTION	Q.TY	LVL	NOTE	LOG P/N
<b>39</b>	<b>109G5330R01-302</b>		<b>LATERAL MOUNTING REINFORCEMENT RH</b>	<b>REF</b>	.		-
40	109-0329-72-185	109-0329-72-185M3	FWD cap RH	1	..	(1)	709-083L1
41	109G5307P39-114		Angle RH	1	..		709-083L1
42	109G5307P39-116		Right cap	1	..		709-083L1
43	109G5307P39-117		Doubler	1	..		709-083L1
44	109G5330A25-102		Stiffener Machined RH	1	..		709-083L1
45	109G5330R01-308		External butt-strap RH	1	..		709-083L1
46	109G5330R01-310		Internal butt-strap RH	1	..		709-083L1
47	109G5330R01-316		Web RH	REF	..	(4)	-
48	109G5330R01-318		Stiffener RH	1	..		709-083L1
49	A879A05L150		Rivet	10	..		709-083L1
50	CR2245-4-2		Rivet	10	..		709-083L1
51	CR2245-4-5		Rivet	10	..		709-083L1
52	CR2245-5-3		Rivet	10	..		709-083L1
53	MS20426AD3-5		Rivet	0.1kg	..		709-083L1
54	MS20426AD4-5		Rivet	0.1kg	..		709-083L1
55	MS20426AD5-5		Rivet	0.1kg	..		709-083L1
56	MS20470AD5-5		Rivet	0.1kg	..		709-083L1
57	MS20470E5-5		Rivet	0.1kg	..		709-083L1
58	MS21071L08		Nut Plate	1	..		709-083L1
59	NAS1739B4-3		Rivet	10	..		709-083L1
60	NAS9301B-4-02		Rivet	100	..		709-083L1
61	NAS9301B-4-03		Rivet	50	..		709-083L1
62	NAS9301B-5-03		Rivet	20	..		709-083L1
63	NAS9302B-4-02		Rivet	20	..		709-083L1
64	NAS9302B-5-04		Rivet	20	..		709-083L1
65	NAS9307M-4-02		Rivet	20	..		709-083L1
66	NAS9307M-4-03		Rivet	20	..		709-083L1
<b>67</b>	<b>109G5330R01-304</b>		<b>ANGLE REPAIR INSTALLATION LH</b>	<b>REF</b>	..		-
68	109G5330R01-306		Angle RH	REF	...	(5)	-
69	109G5330R01-312		Internal butt-strap RH	1	...		709-083L1
70	109G5330R01-314		Internal shim RH	1	...		709-083L1
71	MS20470AD5-5		Rivet	0.1kg	...		709-083L1
72	NAS9307M-4-03		Rivet	20	...		709-083L1
73	MS21069L3		Nut	8	.		709-083L1
74	MS20600AD4W3	CR2245-4-3	Rivet	24	.		709-083L1
75	MS20615M4-4		Rivet	0.1kg	.		709-083L1
76	MS20427M4-4		Rivet	0.1kg	.		709-083L1

### **A.2 CONSUMABLES**

The following consumable materials, or equivalent, are necessary to accomplish this Service Bulletin:

#	Spec./LHD code number	DESCRIPTION	Q.TY	NOTE	PART
77	Commercial	Soft lint-free cloth (C011)	AR	(6)	All
78	MIL-PRF-680 TY II	Cleaning solvent (C287)	AR	(6)	All
79	199-05-002 TY I, Cl 2 (cod. 900000581)	Adhesive EA9309.3NA (C100)	AR	(6)	II, III
80	199-05-004 TY II, Cl 2 (cod. 900001586)	Sealant PROSEAL 890B2 (C148)	AR	(6) (7)	II, III
81	AWMS05-001TY I, Cl B, Gr 2 (cod. 99999999000015245)	Sealant MC780 B-2 (C501)	AR	(6) (7)	II, III

#	Spec./LHD code number	DESCRIPTION	Q.TY	NOTE	PART
82	MIL-PRF-23377 TY I, CI C2 (cod. 99999999000010181)	Primer, epoxy-polyamide (446)	AR	(6)	II, III
83	MIL-PRF-680 TY II	Cleaning solvent (C287)	AR	(6)	All
84	Commercial	Masking tape (C064)	AR	(6)	II, III
85	Commercial	Scotch-Brite (C015)	AR	(6)	II, III

Refer also to AMDI for the consumable materials required to comply with the MM Paragraphs referenced in the accomplishment instructions.

**NOTE**

- (1) Reuse the removed part if it is not damaged.
- (2) This item can be obtained reworking the existing web LH P/N 109-0320-96-505.
- (3) This item can be obtained reworking the existing angle LH P/N 109-0320-96-507.
- (4) This item can be obtained reworking the existing web RH P/N 109-0320-96-506.
- (5) This item can be obtained reworking the existing angle RH P/N 109-0320-96-508.
- (6) Local supply.
- (7) These materials are alternatives.

**A.3 LOGISTIC MATRIX**

In order to apply this Service Bulletin, the following Logistic P/N can be ordered in accordance with the applicable notes:

LOGISTIC P/N	Q.TY (PER HELO)	NOTE	PART
709-083L1	1	-	II, III
109-0329-72-229 or 109-0329-72-229M02	1	(1)	II
109-0329-72-185 or 109-0329-72-185M3	1	(1)	III

**B. SPECIAL TOOLS**

Refer to PTUM for the special tools required to comply with the MM Paragraphs referenced in the accomplishment instructions.

**C. INDUSTRY SUPPORT INFORMATION**

Owners/Operators who comply with the instructions of this Service Bulletin no later than the applicable date in the “Compliance” section will be eligible to receive REQUIRED MATERIALS on free of charge basis, except for Consumable Materials and Special Tools.

NOTE: Customers who fail to comply with the instructions in this Service Bulletin before the compliance date are not eligible for the aforementioned special policy.

Please Issue relevant MMIR form to your Warranty Administration Dpt.



### **3. ACCOMPLISHMENT INSTRUCTIONS**

#### **GENERAL NOTES**

- a) Place an identification tag on all components that are re-usable, including the attaching hardware that have been removed to gain access to the modification area and adequately protect them until their later re-use.
- b) Shape the cables in order to prevent interference with the structure and the other existing installations, using where necessary suitable lacing cords.
- c) Exercise extreme care during drilling operations to prevent instruments, cables and hoses damage.
- d) After drilling, remove all swarf and sharp edges. Apply on bare metal a light film of primer unless the hole is used for ground connection.
- e) Exposed thread surface and nut must be protected using a layer of tectyl according to MIL-C-16173 grade I.
- f) All lengths are expressed in mm.

#### **PART I**

1. In accordance with MM Paragraph 00-20-1, prepare the helicopter on ground for a safe maintenance. Disconnect the battery, all electrical power sources and/or the external power supply.
2. With reference to Figure 1, open both the passenger doors and both the cockpit doors and secure them in opened position to gain access to the indicated areas.
3. If installed, remove any item of furnishing in the passenger compartment that might prevent the access to the inspection zone.
4. If installed, in accordance with MM Paragraphs 25-81-7 and 25-81-9, remove the cockpit and passenger compartment soundproofing panels or the moquette lining that might prevent the access to the inspection zone.
5. With reference to Figure 2, on both lateral posts, remove the access panels on the aft side (P/N 109-0320-96-309 on LH side and P/N 109-0320-96-310 on RH side) and on the inboard side (P/N 109-0320-96-521 on LH side and P/N 109-0320-96-522 on RH side). Retain all the fixing hardware for later reuse.
6. If necessary, clean the inspection area using a soft lint-free cloth (moist with) cleaning

solvent MIL-PRF-680 Type II or equivalent.

7. With reference to Figure 1, using a bright light source, visually inspect the whole zone of intersection between the lateral post and the floor spar, on both sides of the fuselage, for evidence of cracks. Pay particular attention to the forward area of the post (toward cockpit) and to inboard side of the post.
8. In case of no findings, reinstall all the components removed from Step 3 to Step 5 and continue with Step 10.
9. In case of findings, in accordance with CSRP standard repair procedures perform a fluorescent liquid penetrant inspection of the crack to determine the exact extent, then stop-drill at both ends of crack to relieve the stresses in the extremities and to prevent any further propagation.
  - 9.1 If the length of crack on the FWD CAP does not exceed 50 mm and no other damages are detected in the affected area, proceed in accordance with PART II (LH side of fuselage) or PART III (RH side of fuselage) of this Service Bulletin within and not later than the next 25 flight hours otherwise.
  - 9.2 If the length of crack on the FWD CAP is greater than 50 mm and/or any other crack(s) are detected but not exceeding the boundaries of the FWD CAP, INNER FORWARD ANGLE or WEB (ref. Figure 1) proceed in accordance with PART II (LH side of fuselage) or PART III (RH side of fuselage) of this Service Bulletin before the next flight.
  - 9.3 If the length of the cracks exceeds the boundaries of the FWD CAP, INNER FORWARD ANGLE or WEB (ref. Figure 1), the reinforce scheme reported in this Service Bulletin could not be applicable. In this case contact Leonardo Engineering Dept at the following mail box: [engineering.support.lhd@leonardo.com](mailto:engineering.support.lhd@leonardo.com).
10. Return the helicopter to a ready to flight condition and record for compliance with Part I of this Service Bulletin on the helicopter logbook.
11. Gain access to My Communications section on Leonardo WebPortal and compile the "Service Bulletin Application Communication".

As an alternative, send the attached compliance form to the following mail box:

[engineering.support.lhd@leonardo.com](mailto:engineering.support.lhd@leonardo.com)

and (for North, Central and South America) also to:

[AWPC.Engineering.Support@leonardocompany.us](mailto:AWPC.Engineering.Support@leonardocompany.us)

## **PART II**

1. In accordance with MM Paragraph 00-20-1, prepare the helicopter on ground for a safe maintenance. Disconnect the battery, all electrical power sources and/or the external power supply.
2. With reference to Figure 11 and Figure 12, remove the collective control rod assy P/N 109-0032-02-41 and the tail rotor control rod assy P/N 109-0032-02-25 as follows:
  - 2.1 In accordance with MM Paragraph 25-11-9, remove the co-pilot seat.
  - 2.2 If installed, in accordance with MM Paragraph 25-21-12, remove the forward passenger seat.
  - 2.3 In accordance with the pertinent MM Paragraph, remove any other item of equipment/furnishing that might prevent the access to the work area.
  - 2.4 If installed, in accordance with MM Paragraphs 25-81-7 and 25-81-9, remove the cockpit and passenger compartment soundproofing panels or the moquette lining that might prevent the access to the inspection zone.
  - 2.5 In accordance with MM Paragraph 21-21-1, remove the air distribution duct P/N 109-0710-32-105 from the left door post.
  - 2.6 Remove the access panel P/N 109-0329-72-305 or P/N 109-0329-72-417.
  - 2.7 Remove the access door P/N 109-0325-73-305 on the upper part of the fuselage, over the door post.
  - 2.8 Using masking tape, identify the position and the sense of installation of each control rod assy.
  - 2.9 With reference to Figure 11, on the lower end of the collective control rod assy, remove the cotter pin, the nut, the bolt and the washers that attach the lower end of the control rod assy to the lever. Discard the cotter pin. If necessary, move slightly the collective control lever and/or the pedals to allow an easy removal of the bolt.

### **CAUTION**

**During the hardware removing, keep the rod assy to prevent it from falling.**

- 2.10 With reference to Figure 11, on the upper end of the collective control rod assy, remove the cotter pin, the nut, the bolt and the washers that attach the upper end of the control rod assy to the lever. Discard the cotter pin.

**NOTE**

Do not change the length of the collective control rod assy.

**CAUTION**

Apply the maximum care to prevent any damage to the control rod caused by rubbing with other parts of the helicopter.

- 2.11 Withdraw the collective control rod assy from the upper side of helicopter.
- 2.12 With reference to Figure 12, on the lower end of the tail rotor control rod assy, remove the cotter pin, the nut, the bolt and the washer that attach the lower end of the control rod assy to the lever. Discard the cotter pin.

**CAUTION**

During the hardware removing, keep the rod assy to prevent it from falling.

- 2.13 With reference to Figure 12, on the upper end of the tail rotor control rod assy, remove, the nut, the bolt and the washer that attach the lower end of the control rod assy to the lever. Discard the cotter pin.

**NOTE**

Do not change the length of the tail rotor control rod assy.

**CAUTION**

Apply the maximum care to prevent any damage to the control rod caused by rubbing with other parts of the helicopter.

- 2.14 Withdraw the tail rotor control rod assy from the upper side of helicopter.
3. In accordance with MM Paragraph 52-11-9, remove the pilot and co-pilot door. Open both the passenger compartment doors and lock them in opened position.
4. Remove the co-pilot door seal assy P/N 109-0360-88-109 and the passenger door seal assy P/N 109-0360-86-109. Remove any trace of adhesive and rubber from installation areas using a plastic scraper and a soft cloth moistened with solvent.
5. In accordance with MM Paragraph 25-11-9, remove the pilot seat.
6. Remove the support panels located under the pilot and co-pilot seat. Remove also the centre panel located between the seats and any control located on it (e.g. friction knob, cargo hook release handle).
7. If installed, in accordance with MM Paragraphs 67-00-12 and 67-11-9, remove the co-pilot

- collective control lever.
8. Set the collective control in fully-up position then lock the collective torque tube using the friction.
  9. Remove the collective lever guard assy P/N 109-0700-25-127 (if the helicopter is equipped with dual control) or the fairing P/N 109-0011-28-1 (if the helicopter is not equipped with dual control).
  10. Remove and retain for later re-use all the access panels located on the door sill and on the post.
  11. With reference to Figure 2, remove the access panels P/N 109-0320-96-521 and P/N 109-0320-96-309 located on the post. Retain all the fixing hardware for later reuse.
  12. Remove the air conditioning duct located inside the door lower sill. Cap thoroughly the open ends of the adjacent ducts to prevent any unwanted entry of foreign materials in the air conditioning system.
  13. Remove the collective stick connector located on the right side of the co-pilot seat support structure. Wrap the connector using a plastic sheet and stow it in a safe place.
  14. In accordance with MM Paragraphs 67-00-12 and 67-11-9, remove the collective control torque tube. To make easier the reinstallation of the torque tube at the end of the repair, it is advisable to mark the position of the following components on the torque tube using a thin felt-tip pen:
    - LVDT sensors (collective transducers);
    - Engine-out switch (if installed in accordance with SB 109EP-081);
    - Collective friction;
    - Support on the LH side of the torque tube.
  15. With reference to Figure 13, remove the LH post center fairing P/N 109-0324-29-101 by removing the related attaching screws.
  16. Remove the cockpit/passenger doors caution system switch from the fairing removed at previous Step 15 by removing the two attaching screws. Leave the switch attached to the wire. Take note of quantity of shims below the switch in order to allow the reinstallation in their original position.
  17. If applied, remove any sill-liner or anti-slip paint from the upper side of the fairings P/N 109-0324-25-303 and 109-0324-30-101.
  18. In accordance with MM Paragraphs 07-30-1 or 07-30-2, raise the helicopter using the lifting device P/N 109-3900-01-1 connected to a suitable crane/hoist and put the cable in tension.
  19. With reference to Figure 13, remove the LH lower fairing P/N 109-0324-25-303 by drilling-out the attaching rivets. Break the sealant layer between the fairing and the structure using a thin blade or putty knife.

20. With reference to Figure 13, remove the LH post lower fairing P/N 109-0324-30-101 by drilling-out the attaching rivets. Break the sealant layer between the fairing and the structure using a thin blade or putty knife.
21. Remove any trace of sealant from the structure and from the inner side of the fairings P/N 109-0324-25-303 and 109-0324-30-101 using a plastic scraper or putty knife. Clean thoroughly using Scotch-Brite and a clean, lint-free cloth moistened with cleaning solvent MIL-PRF-680 TY II.
22. Drill-out all the rivets that attach the forward LH cap, the forward LH protection P/N 109-0311-40-133 and the doubler P/N 109-0311-40-128 (under the forward LH protection P/N 109-0311-40-133). Break the sealant layer between the cap, the protection, the doubler and the structure using a thin blade or putty knife. Remove any trace of sealant from the structure using a plastic scraper or putty knife. Clean thoroughly using Scotch-Brite and a clean, lint-free cloth moistened with cleaning solvent MIL-PRF-680 TY II.
23. If installed, remove and retain for later reuse any additional shim that is installed between the rear part of the forward LH cap and the post structure.
24. With reference to Figure 18, remove the FWD cap LH P/N 109-0329-72-229. Discard only if the part is damaged.
25. With reference to Figure 18, remove the left cap P/N 109-0329-72-151.
26. With reference to Figure 20 View T-T, temporarily remove the FWD bulkhead LH P/N 109-0320-96-311, the web LH P/N 109-0329-72-129 and the bracket LH P/N 109-0320-90-41.
27. With reference to Figure 21, remove the filler P/N 109-0329-72-407.
28. With reference to Figure 18, install the angle LH P/N 109G5307P39-113 by means of adhesive EA9309.3NA.
29. With reference to Figure 21, install the stiffener machined LH P/N 109G5330A25-101 by means of adhesive EA9309.3NA.
30. With reference to Figure 17 thru Figure 21, install the following parts by means of the indicated rivets:
  - the left cap P/N 109G5307P39-115;
  - the doubler P/N 109G5307P39-117;
  - the previously removed FWD bulkhead LH P/N 109-0320-96-311,
  - the previously removed web LH P/N 109-0329-72-129;
  - the previously removed angle LH P/N 109-0320-90-41.
31. With reference to Figure 22 thru Figure 24, find and mark the cutting line for the web LH P/N 109-0320-96-505 (or P/N 109-0320-96-71). Identify and remove all the rivets that attach the web to angle LH P/N 109-0320-96-507 (or P/N 109-0320-96-73), to forward and aft bulkheads P/N 109-0320-96, and to the other internal part of the post. Using a putty

knife, break the sealant/adhesive between the parts.

32. With reference to Figure 23, identify and remove the twelve additional rivets that attach the web LH P/N 109-0320-96-505 (or P/N 109-0320-96-71) to the forward and aft bulkheads. They must be removed to allow installation of the butt-straps.
33. Remove the rivets that have been identified and marked in the previous Steps 31 and 32.

**NOTE**

Insert a thin steel sheet between the web and the forward and aft bulkheads to avoid damages while cutting the metal.

34. With reference to Figure 22 thru Figure 24, cut the web LH P/N 109-0320-96-505 (or P/N 109-0320-96-71).

**NOTE**

Perform the following Steps from 35 to 48 ONLY if the angle LH P/N 109-0320-96-507 (or P/N 109-0320-96-73) is damaged, otherwise skip to Step 49.

35. With reference to Figure 25 and Figure 26, identify and mark the cutting lines for angle LH P/N 109-0320-96-507 (or P/N 109-0320-96-73) and for the existing internal doubler. The slant of cut shown in figure is indicative. Always make sure that cutting lines are equally spaced from the adjacent rivets. Identify all the rivets that attach the portion of angle to other structural elements of the post.
36. With reference to Figure 25, remove the rivets identified in the previous Step 35.
37. With reference to Figure 21, remove the two rivets that attach the nut-plate to the forward side of the post. Discard the nut-plate.
38. With reference to Figure 25 and Figure 26, cut the angle LH P/N 109-0320-96-507 (or P/N 109-0320-96-73) and the existing internal doubler.
39. With reference to Figure 22 thru Figure 27, put the new angle LH P/N 109G5330R01-305, the new internal butt-strap LH P/N 109G5330R01-311, the new internal shim LH P/N 109G5330R01-313, the new web LH P/N 109G5330R01-315, the new internal butt-strap LH P/N 109G5330R01-309 and the new stiffener LH P/N 109G5330R01-317 in position on interior of the post. Mark the exact length of the angle LH P/N 109G5330R01-305, depending on the cutting position of the existing angle.
40. With reference to Figure 25 and Figure 26, mark the exact length of the internal butt-strap LH P/N 109G5330R01-311 and of the internal shim LH P/N 109G5330R01-313.

### NOTE

When marking the position of the rivet holes, make sure that the distance between the hole centre and the edge of the sheet is at least 2.5 times the diameter of the rivet.

41. Remove the new angle LH P/N 109G5330R01-305, the new internal butt-strap LH P/N 109G5330R01-311 and the new internal shim LH P/N 109G5330R01-313 and cut them to the exact length as defined in Steps 39 and 40. Reinstall the items in position and mark the position of the rivet holes.
42. Drill the holes to attach the new angle LH P/N 109G5330R01-305, the new internal butt-strap LH P/N 109G5330R01-311, the new internal shim LH P/N 109G5330R01-313, the new web LH P/N 109G5330R01-315, the new internal butt-strap LH P/N 109G5330R01-309 and the new stiffener LH P/N 109G5330R01-317 to forward and aft bulkheads P/N 109-0320-96. Attach the parts in position with Cleco fasteners.
43. Put the web LH P/N 109G5330R01-315 in position on the post. Drill the holes to secure the new internal butt-strap LH P/N 109G5330R01-311.
44. With reference to Figure 23, put the external butt-strap LH P/N 109G5330R01-307 in position. If necessary, adapt the shape to the profile of the post to allow the correct installation. Mark and drill the attachment holes.
45. Remove the paint from the existing web LH P/N 109-0320-96-505 (or P/N 109-0320-96-71) and from the new web LH P/N 109G5330R01-315 in the area of installation of the external butt-strap LH P/N 109G5330R01-307.
46. With reference to Figure 23 View W, install n°8 nut-plates P/N MS21069L3 by means of n°16 rivets P/NMS20426AD3.

### NOTE

For accessibility reason, it is allowed to install rivets P/N A879A05L150 on opposite direction (rivet from outside to inside STA1815 honeycomb).

47. With reference to Figure 22 thru Figure 27, put in position the new angle LH P/N 109G5330R01-305, the new internal butt-strap LH P/N 109G5330R01-311, the new internal shim LH P/N 109G5330R01-313, the new web LH P/N 109G5330R01-315, the new internal butt-strap LH P/N 109G5330R01-309 and the new stiffener LH P/N 109G5330R01-317. Install by means of adhesive EA9309.3NA. Starting from the forward side of the post, install the rivets. Seal edges by means of sealant MC780 B-2.
48. With reference to Figure 22 thru Figure 24, install the external butt-strap LH P/N 109G5330R01-307 to the post by means of adhesive EA9309.3NA and rivets. Seal edges by means of sealant PROSEAL 890B2 or MC780 B-2.



### NOTE

Perform the following Steps from 49 to 56 ONLY if the angle LH P/N 109-0320-96-507 (or P/N 109-0320-96-73) is undamaged.

49. With reference to Figure 21, remove the two rivets that attach the nut-plate to the forward side of the post. Discard the nut-plate.
50. With reference to Figure 22 thru Figure 24, put the new web LH P/N 109G5330R01-315, the new internal butt-strap LH P/N 109G5330R01-309 and the new stiffener LH P/N 109G5330R01-317 in position on interior of the post.

### NOTE

When marking the position of the rivet holes, make sure that the distance between the hole centre and the edge of the sheet is at least 2.5 times the diameter of the rivet.

51. Drill the holes to attach the new web LH P/N 109G5330R01-315, the new internal butt-strap LH P/N 109G5330R01-309 and the new stiffener LH P/N 109G5330R01-317 to forward and aft bulkheads P/N 109-0320-96. Attach the parts in position with Cleco fasteners.
52. With reference to Figure 23, put the external butt-strap LH P/N 109G5330R01-307 in position. If necessary, adapt the shape to the profile of the post to allow the correct installation. Mark and drill the attachment holes.
53. Remove the paint from the existing web LH P/N 109-0320-96-505 (or P/N 109-0320-96-71) and from the new web LH P/N 109G5330R01-315 in the area of installation of the external butt-strap LH P/N 109G5330R01-307.
54. With reference to Figure 23 View W, install n°8 nut-plates P/N MS21069L3 by means of n°16 rivets P/N MS20426AD3.

### NOTE

For accessibility reason, it is allowed to install rivets P/N A879A05L150 on opposite direction (rivet from outside to inside STA1815 honeycomb).

55. With reference to Figure 22 thru Figure 24, put in position the new web LH P/N 109G5330R01-315, the new internal butt-strap LH P/N 109G5330R01-309 and the new stiffener LH P/N 109G5330R01-317. Install by means of adhesive EA9309.3NA. Starting from the forward side of the post, install the rivets. Seal edges by means of sealant MC 780 B-2.
56. With reference to Figure 22 thru Figure 24, install the external butt-strap LH P/N 109G5330R01-307 to the post by means of adhesive EA9309.3NA and rivets. Seal

edges by means of sealant PROSEAL 890B2 or MC780 B-2.

57. With reference to Figure 22, reinstall and bond with adhesive EA9309.3NA all the shims that were installed under the lower end of forward LH bulkhead P/N 109-0320-96.

**NOTE**

Make sure that the rivets in the zone of installation of the torque tube support P/N 109-0011-18-1 have the countersunk head on both sides. Make sure that the head does not protrude over the surface. Flush the heads if necessary.

**NOTE**

Reuse the removed part if it is not damaged.

58. With reference to Figure 18, Figure 19 and Figure 28, put the FWD cap LH P/N 109-0329-72-229 in position and bond by means of adhesive EA9309.3NA and sealant PROSEAL 890B2 or MC780 B-2. Install the forward cap by means of the indicated rivets. Seal the edges of the forward LH cap by means of sealant PROSEAL 890B2 or MC 780 B-2.
59. With reference to Figure 21, install the nut-plate P/N MS21071L08 in the indicated position by means of the rivets.
60. Temporarily put the LH post lower fairing P/N 109-0324-30-101 and the LH lower fairing P/N 109-0324-25-303 in position and drill the rivet holes in the upper part of the FWD cap LH P/N 109-0329-72-229.
61. Touch-up the exposed areas of the repaired zones with primer and paint to restore the original aspect.
62. With reference to Figure 13, bond with sealant PROSEAL 890B2 or MC780 B-2 then attach with rivets the LH lower fairing P/N 109-0324-25-303. Make sure that that the drain holes in the fairing are not plugged by the sealant.
63. With reference to Figure 13, bond with sealant PROSEAL 890B2 or MC780 B-2 then attach with rivets the LH post lower fairing P/N 109-0324-30-101. Make sure that that the drain holes in the fairing are not plugged by the sealant.
64. In accordance with MM Paragraphs 07-30-1 or 07-30-2, lay down the helicopter.
65. Reinstall the cockpit/passenger doors caution system switch on the LH post center fairing P/N 109-0324-29-101 using the related screws. Put the shims (if any) in their original position.
66. With reference to Figure 13, reinstall the LH post center fairing P/N 109-0324-29-101 using the related attaching screws.
67. If originally installed, reinstall the sill-liner or apply the anti-slip paint on the upper side of

- the fairings P/N 109-0324-25-303 and P/N 109-0324-30-101.
68. Reinstall the cockpit and passenger doors seals.
  69. In accordance with MM Paragraph 21-21-1, reinstall the air conditioning duct located inside the door lower sill.
  70. Reinstall the collective stick connector removed at Step 13.
  71. In accordance with MM Paragraphs 67-00-12 and 67-11-9, reinstall the collective control torque tube.
  72. If removed (Ref. Step 7), in accordance with MM Paragraphs 67-00-12 and 67-11-9, reinstall the co-pilot collective control lever.
  73. With reference to Figure 11 and Figure 12, reinstall the collective control rod assy P/N 109-0032-02-41 and the tail rotor control rod assy P/N 109-0032-02-25 as follows:

**CAUTION**

Apply the maximum care to prevent any damage to the control rod caused by rubbing with other parts of the helicopter.

- 73.1 Put the collective control rod assy in position on interior of the left cabin post by inserting it from the top. Observe the correct sense of installation, as identified in previous Step 2.8.
- 73.2 Attach the upper end of the collective control rod assy to the lever using the bolt P/N AN174-12, the washer P/N A160A0432K (under bolt head and with countersunk side toward the bolt head), the washer P/N AN960-PD416 (under the nut) and the nut P/N MS17825-4. Torque the nut to 3.4 thru 4.5 Nm and install a new cotter pin P/N MS24665-153.
- 73.3 Attach the lower end of the collective control rod assy to the lever using the bolt P/N AN174-12, the washer P/N A160A0432K (under bolt head and with countersunk side toward the bolt head), the washer P/N AN960-PD416 (under the nut) and the nut P/N MS17825-4. If necessary, move slightly the collective control lever as necessary to allow the insertion of the bolt. Torque the nut to 3.4 thru 4.5 Nm and install a new cotter pin P/N MS24665-153.

**CAUTION**

Apply the maximum care to prevent any damage to the control rod caused by rubbing with other parts of the helicopter.

- 73.4 Put the tail rotor control rod assy in position on interior of the left cabin post by inserting it from the top. Observe the correct sense of installation, as identified in previous Step 2.8.

- 73.5 Attach the upper end of the tail rotor control rod assy to the lever using the bolt P/N AN174-12, the washer P/N AN960-PD416 under the nut and the nut P/N MS17825-4. Torque the nut to 3.4 thru 4.5 Nm and install a new cotter pin P/N MS24665-151.
  - 73.6 Attach the lower end of the tail rotor control rod assy to the lever using the bolt P/N AN174-12, the washer P/N AN960-PD416 under the nut and the nut P/N MS17825-4. If necessary, move slightly the pedals as necessary to allow the insertion of the bolt. Torque the nut to 3.4 thru 4.5 Nm and install a new cotter pin P/N MS24665-151.
  - 73.7 Remove the masking tape that has been put on the rods to identify the direction of installation (ref. Step 2.8).
  - 73.8 Perform a duplicate inspection of installation of the control rods. The duplicate inspection must include, but is not limited to, correct assembly, security, correct application of cotter pins, thread engagement and protrusion, and a functional check for complete range, freedom of movement and operation in correct sense.
74. For the collective installation affected by collective control rod assy P/N 109-0032-02-41 and Torque Tube removal and re-installation, perform the following step of MM Paragraph 67-11A-24 (ref. Figures 3 thru 10):
- Step R;
  - Step S. Being collective control rod assy P/N 109-0032-02-41 mechanically connected to the lower and upper lever, as per Step 73.2 and 73.3, also the mixing unit will be moved FWD. Pay attention to provide hydraulic power supply at 1500 PSI before moving the stick;
  - Check that the minimum Collective Stop is engaged as per the second part of Step X. If not, apply the following Step from Step B up to Step AG;
  - Step AE;
  - Loosen the adjustable friction;
  - Move the collective stick three or four times. Make sure that the collective controls are free to operate without friction against the structure.
75. Perform an operational test of the collective control system, and of the tail rotor control system, to make sure that the control linkages move freely.
76. Reinstall all the access panels you have removed to perform the repair.
77. Reinstall the collective lever guard assy P/N 109-0700-25-127 (if the helicopter is equipped with dual control) or the fairing P/N 109-0011-28-1 (if the helicopter is not equipped with dual control).
78. Reinstall the support panels located under the pilot and co-pilot seat. Reinstall also the centre panel located between the seats and any control located on it (e.g. friction knob,

- cargo hook release handle).
79. Reinstall the access door P/N 109-0325-73-305 on the upper part of the fuselage, over the door post, and move the platform away from helicopter.
  80. Reinstall the access panel P/N 109-0329-72-305 or 109-0329-72-417.
  81. In accordance with MM Paragraph 21-21-1, reinstall the air distribution duct P/N 109-0710-32-105 on the door post.
  82. With reference to the pertinent MM Paragraph, reinstall all the items of equipment/furnishing that were removed to gain access to work area.
  83. If originally installed, in accordance with MM Paragraph 25-21-12, reinstall the forward passenger seat.
  84. In accordance with MM Paragraph 25-11-9, reinstall the pilot and co-pilot seat.
  85. If originally installed, in accordance with MM Paragraphs 25-81-7 and 25-81-9, reinstall the cockpit and passenger compartment soundproofing panels or the moquette lining.
  86. In accordance with MM Paragraph 52-11-9, reinstall the pilot and co-pilot doors and close the passenger compartment doors.
  87. In accordance with MM Paragraph 52-71-6, perform an operational test of the cockpit/passenger doors caution system.
  88. In accordance with weight and balance changes, update the Chart A (see Rotorcraft Flight Manual, Part II, section 6).
  89. Return the helicopter to a ready to flight condition and record for compliance with Part II of this Service Bulletin on the helicopter logbook.
  90. Gain access to My Communications section on Leonardo WebPortal and compile the "Service Bulletin Application Communication".

As an alternative, send the attached compliance form to the following mail box:

[engineering.support.lhd@leonardo.com](mailto:engineering.support.lhd@leonardo.com)

and (for North, Central and South America) also to:

[AWPC.Engineering.Support@leonardocompany.us](mailto:AWPC.Engineering.Support@leonardocompany.us)

### **PART III**

1. In accordance with MM Paragraph 00-20-1, prepare the helicopter on ground for a safe maintenance. Disconnect the battery, all electrical power sources and/or the external power supply.
2. With reference to Figure 14 and Figure 15, remove the lateral cyclic control rod assy P/N 109-0032-19-101 and the longitudinal cyclic control rod assy P/N 109-0032-07-01 as follows:
  - 2.1 In accordance with MM Paragraph 25-11-9, remove the pilot seat.
  - 2.2 If installed, in accordance with MM Paragraph 25-21-12, remove the forward passenger seat.
  - 2.3 In accordance with the pertinent MM Paragraph, remove any other item of equipment/furnishing that might prevent the access to the work area.
  - 2.4 If installed, in accordance with MM Paragraphs 25-81-7 and 25-81-9, remove the cockpit and passenger compartment soundproofing panels or the moquette lining that might prevent the access to the inspection zone.
  - 2.5 In accordance with MM Paragraph 21-21-1, remove the air distribution duct P/N 109-0710-32-106 from the right door post.
  - 2.6 Remove the access panel P/N 109-0329-72-307 or 109-0329-72-419.
  - 2.7 Remove the access door P/N 109-0325-73-335 on the upper part of the fuselage, over the door post.
  - 2.8 Using masking tape, identify the position and the sense of installation of each control rod assy.
  - 2.9 With reference to Figure 14, on the lower end of the lateral cyclic control rod assy, remove the cotter pin, the nut, the bolt and the washers that attach the lower end of the control rod assy to the lever. Discard the cotter pin. If necessary, move slightly the cyclic control stick to allow an easy removal of the bolt.

#### **CAUTION**

**During the hardware removing, keep the rod assy to prevent it from falling.**

- 2.10 With reference to Figure 14, on the upper end of the lateral cyclic control rod assy, remove the cotter pin, the nut, the bolt and the washers that attach the upper end of the control rod assy to the lever. Discard the cotter pin.

**NOTE**

Do not change the length of the lateral cyclic control rod assy.

**CAUTION**

Apply the maximum care to prevent any damage to the control rod caused by rubbing with other parts of the helicopter.

- 2.11 Withdraw the lateral cyclic control rod assy toward the upper side of helicopter.
- 2.12 With reference to Figure 15, on the lower end of the longitudinal cyclic control rod assy, remove the cotter pin, the nut, the bolt and the washers that attach the lower end of the control rod assy to the lever. Discard the cotter pin.

**CAUTION**

During the hardware removing, keep the rod assy to prevent it from falling.

- 2.13 With reference to Figure 15, on the upper end of the longitudinal cyclic control rod assy, remove the cotter pin, the nut, the bolt and the washers that attach the upper end of the control rod assy to the lever. Discard the cotter pin.

**NOTE**

Do not change the length of the longitudinal cyclic control rod assy.

**CAUTION**

Apply the maximum care to prevent any damage to the control rod caused by rubbing with other parts of the helicopter.

- 2.14 Withdraw the longitudinal cyclic control rod assy toward the upper side of helicopter.
3. In accordance with MM Paragraph 52-11-9, remove the pilot and co-pilot door. Open both the passenger compartment doors and lock them in opened position.
4. Remove the pilot door seal assy P/N 109-0360-88-110 and the passenger door seal assy P/N 109-0360-86-110. Remove any trace of adhesive and rubber from installation areas using a plastic scraper and a soft cloth moistened with solvent.
5. In accordance with MM Paragraph 25-11-9, remove the co-pilot seat.
6. Remove the support panels located under the pilot and co-pilot seat. Remove also the centre panel located between the seats and any control located on it (e.g. friction knob, cargo hook release handle).

7. Remove and retain for later re-use all the access panels located on the door sill and on the post.
8. With reference to Figure 2, remove the access panels P/N 109-0320-96-522 and P/N 109-0320-96-310 located on the post. Retain all the fixing hardware for later reuse.
9. Remove the air conditioning duct located inside the door lower sill. Cap thoroughly the open ends of the adjacent ducts to prevent any unwanted entry of foreign materials in the air conditioning system.
10. In accordance with MM Paragraphs 67-00-12 and 67-12-1, remove and retain for later reuse the following components of the flight control system:
  - Lateral cyclic control rod P/N 109-0032-01-1;
  - Longitudinal cyclic control rod P/N 109-0032-03-1;
  - Lateral cyclic lever P/N 109-0020-17-1;
  - Lateral cyclic control rod P/N 109-0032-02-1.
11. With reference to Figure 16, remove the RH post center fairing P/N 109-0324-29-102 by removing the related attaching screws.
12. Remove the cockpit/passenger doors caution system switch from the fairing removed at previous Step 11 by removing the two attaching screws. Leave the switch attached to the wire. Take note of quantity of shims below the switch in order to allow the reinstallation in their original position.
13. If applied, remove any sill-liner or anti-slip paint from the upper side of the fairings P/N 109-0324-25-304 and 109-0324-30-102.
14. In accordance with MM Paragraphs 07-30-1 or 07-30-2, raise the helicopter using the lifting device P/N 109-3900-01-1 connected to a suitable crane/hoist and put the cable in tension.
15. With reference to Figure 16, remove the RH lower fairing P/N 109-0324-25-304 by drilling-out the attaching rivets. Break the sealant layer between the fairing and the structure using a thin blade or putty knife.
16. With reference to Figure 16, remove the RH post lower fairing P/N 109-0324-30-102 by drilling-out the attaching rivets. Break the sealant layer between the fairing and the structure using a thin blade or putty knife.
17. Remove any trace of sealant from the structure and from the inner side of the fairings P/N 109-0324-25-304 and 109-0324-30-102 using a plastic scraper or putty knife. Clean thoroughly using Scotch-Brite and a clean, lint-free cloth moistened with cleaning solvent MIL-PRF-680 TY II.
18. Drill-out all the rivets that attach the forward RH cap, the forward RH protection P/N 109-0311-40-134 and the doubler P/N 109-0311-40-128 (under the forward RH protection P/N 109-0311-40-134). Break the sealant layer between the cap, the protection,



- the doubler and the structure using a thin blade or putty knife. Remove any trace of sealant from the structure using a plastic scraper or putty knife. Clean thoroughly using Scotch-Brite and a clean, lint-free cloth moistened with cleaning solvent MIL-PRF-680 TY II.
19. If installed, remove and retain for later reuse any additional shim that is installed between the rear part of the forward RH cap and the post structure.
  20. With reference to Figure 18, remove the FWD cap RH P/N 109-0329-72-185. Discard only if the part is damaged.
  21. With reference to Figure 18, remove the right cap P/N 109-0320-72-152.
  22. With reference to Figure 20 View T-T, temporarily remove the FWD bulkhead RH P/N 109-0320-96-312, the web RH P/N 109-0329-72-193 and the angle RH P/N 109-0320-90-42.
  23. With reference to Figure 21, remove the filler P/N 109-0329-72-407.
  24. With reference to Figure 18, install the angle RH P/N 109G5307P39-114 by means of adhesive EA9309.3NA.
  25. With reference to Figure 21, install the stiffener machined RH P/N 109G5330A25-102 by means of adhesive EA9309.3NA.
  26. With reference to Figure 17 thru Figure 21, install the following parts by means of the indicated rivets:
    - the left cap P/N 109G5307P39-116;
    - the doubler P/N 109G5307P39-117;
    - the previously removed FWD bulkhead RH P/N 109-0320-96-312,
    - the previously removed web RH P/N 109-0329-72-193;
    - the previously removed angle RH P/N 109-0320-90-42.
  27. With reference to Figure 22 thru Figure 27, find and mark the cutting line for the web RH P/N 109-0320-96-506 (or P/N 109-0320-96-72). Identify and remove all the rivets that attach the web to angle RH P/N 109-0320-96-508 (or P/N 109-0320-96-74), to forward and aft bulkheads P/N 109-0320-96, and to the other parts of the post. Using a putty knife, break the sealant/adhesive between the parts.
  28. With reference to Figure 23, identify and remove the twelve additional rivets that attach the angle RH P/N 109-0320-96-506 (or P/N 109-0320-96-72) to the forward and aft bulkheads. They must be removed to allow installation of the external butt-strap RH P/N 109G5330R01-308.
  29. Remove the rivets that have been identified and marked in the previous Steps 27 and 28.

**NOTE**

Insert a thin steel sheet between the web and the forward and aft bulkheads to avoid damages while cutting the metal.

30. With reference to Figure 22 thru Figure 24, cut the web RH P/N 109-0320-96-506 (or P/N 109-0320-96-72).

**NOTE**

Perform the following Steps from 31 to 44 ONLY if the angle RH P/N 109-0320-96-508 (or P/N 109-0320-96-74) is damaged, otherwise skip to Step 45.

31. With reference to Figure 25 and Figure 26, identify and mark the cutting lines for angle RH P/N 109-0320-96-508 (or P/N 109-0320-96-74) and for the existing internal doubler. The slant of cut shown in figure is indicative. Always make sure that cutting lines are equally spaced from the adjacent rivets. Identify all the rivets that attach the portion of angle to other structural elements of the post.
32. With reference to Figure 25 and Figure 26, remove the rivets identified in the previous Step 31.
33. With reference to Figure 21, remove the two rivets that attach the nut-plate to the forward side of the post. Discard the two nut-plates.
34. With reference to Figure 25 and Figure 26, cut the angle P/N 109-0320-96-508 (or P/N 109-0320-96-74).
35. With reference to Figure 22 thru Figure 27, put the new angle RH P/N 109G5330R01-306, the new internal butt-strap RH P/N 109G5330R01-312, the new internal shim RH P/N 109G5330R01-314, the new web RH P/N 109G5330R01-316, the new internal butt-strap RH P/N 109G5330R01-310 and the new stiffener RH P/N 109G5330R01-318 in position on interior of the post. Mark the exact length of the angle RH P/N 109G5330R01-306, depending on the cutting position of the existing angle.
36. With reference to Figure 25 and Figure 26, mark the exact length of the internal butt-strap RH P/N 109G5330R01-312 and of the internal shim RH P/N 109G5330R01-314.

**NOTE**

When marking the position of the rivet holes, make sure that the distance between the hole centre and the edge of the sheet is at least 2.5 times the diameter of the rivet.

37. Remove the new angle RH P/N 109G5330R01-306, the new internal butt-strap RH P/N 109G5330R01-312, the new internal shim RH P/N 109G5330R01-314 and cut them

to the exact length as defined in Steps 35 and 36 above. Reinstall the items in position and mark the position of the rivet holes.

38. Drill the holes to attach the new angle RH P/N 109G5330R01-306, the new internal butt-strap RH P/N 109G5330R01-312, the new internal shim RH P/N 109G5330R01-314, the new web RH P/N 109G5330R01-316, the new internal butt-strap RH P/N 109G5330R01-310 and the new stiffener RH P/N 109G5330R01-318 to forward and aft bulkheads P/N 109-0320-96. Attach the parts in position with Cleco fasteners.
39. Put the new web RH P/N 109G5330R01-316 in position on the post. Drill the holes to secure the new internal butt-strap RH P/N 109G5330R01-312.
40. With reference to Figure 22, put the new external butt-strap RH P/N 109G5330R01-308 in position. If necessary, adapt the shape to the profile of the post to allow the correct installation. Mark and drill the attachment holes.
41. Remove the paint from the existing web RH P/N 109-0320-96-506 (or P/N 109-0320-96-72) and from the new web RH P/N 109G5330R01-316 in the area of installation of the external butt-strap RH P/N 109G5330R01-308.
42. With reference to Figure 23 View W, install n°8 nut-plates P/N MS21069L3 by means of n°16 rivets P/NMS20426AD3.

**NOTE**

For accessibility reason, it is allowed to install rivets P/N A879A05L150 on opposite direction (rivet from outside to inside STA1815 honeycomb).

43. With reference to Figure 22 thru Figure 27, put in position the new angle RH P/N 109G5330R01-306, the new internal butt-strap RH P/N 109G5330R01-312, the new internal shim RH P/N 109G5330R01-314, the new web RH P/N 109G5330R01-316, the new internal butt-strap RH P/N 109G5330R01-310 and the new stiffener RH P/N 109G5330R01-318. Install by means of adhesive EA9309.3NA. Starting from the forward side of the post, install the rivets. Seal edges by means of sealant MC780 B-2.
44. With reference to Figure 22 thru Figure 24, install the external butt-strap RH P/N 109G5330R01-308 to the post by means of adhesive EA9309.3NA and rivets. Seal edges by means of sealant PROSEAL 890B2 or MC780 B-2.

**NOTE**

Perform the following Steps from 45 to 52 ONLY if the angle P/N 109-0320-96-508 (or P/N 109-0320-96-74) is undamaged.

45. With reference to Figure 21, remove the two rivets that attach the nut-plate to the forward side of the post. Discard the nut-plate.

46. With reference to Figure 22 thru Figure 24, put the new web RH P/N 109G5330R01-316, the new internal butt-strap RH P/N 109G5330R01-310 and the new stiffener RH P/N 109G5330R01-318 in position on interior of the post.

**NOTE**

When marking the position of the rivet holes, make sure that the distance between the hole centre and the edge of the sheet is at least 2.5 times the diameter of the rivet.

47. Drill the holes to attach the new web RH P/N 109G5330R01-316, the new internal butt-strap RH P/N 109G5330R01-310 and the new stiffener RH P/N 109G5330R01-318 to forward and aft bulkheads P/N 109-0320-96. Attach the parts in position with Cleco fasteners.
48. With reference to Figure 22, put the external butt-strap RH P/N 109G5330R01-308 in position. If necessary, adapt the shape to the profile of the post to allow the correct installation. Mark and drill the attachment holes.
49. Remove the paint from the existing web RH P/N 109-0320-96-506 (or P/N 109-0320-96-72) and from the new web RH P/N 109G5330R01-316 in the area of installation of the external butt-strap RH P/N 109G5330R01-308.
50. With reference to Figure 23 View W, install n°8 nut-plates P/N MS21069L3 by means of n°16 rivets P/N MS20426AD3.

**NOTE**

For accessibility reason, it is allowed to install rivets P/N A879A05L150 on opposite direction (rivet from outside to inside STA1815 honeycomb).

51. With reference to Figure 22 thru Figure 24, put in position the new web RH P/N 109G5330R01-316, the new internal butt-strap RH P/N 109G5330R01-310 and the new stiffener RH P/N 109G5330R01-318. Install by means of adhesive EA9309.3NA. Starting from the forward side of the post, install the rivets. Seal edges by means of sealant MC 780 B-2.
52. With reference to Figure 22 thru Figure 24, install the external butt-strap RH P/N 109G5330R01-308 to the post by means of adhesive EA9309.3NA and rivets. Seal edges by means of sealant PROSEAL 890B2 or MC780 B-2.
53. With reference to Figure 22, reinstall and bond with EA9309.3NA all the shims that were installed under the lower end of forward RH bulkhead P/N 109-0320-96.

### NOTE

Make sure that the rivets in the zone of installation of the torque tube support P/N 109-0011-18-1 have the countersunk head on both sides. Make sure that the head does not protrude over the surface. Flush the heads if necessary.

### NOTE

Reuse the removed part if it is not damaged.

54. With reference to Figure 18, Figure 19 and Figure 28, put the FWD cap RH P/N 109-0329-72-185 in position and bond by means of adhesive EA9309.3NA and sealant PROSEAL 890B2 or MC780 B-2. Install the forward cap by means of the indicated rivets. Seal the edges of the forward LH cap by means of sealant PROSEAL 890B2 or MC780 B-2.
55. With reference to Figure 21, install the nut-plate MS21071L08 in the indicated position by means of the rivets.
56. Temporarily put the RH post lower fairing P/N 109-0324-30-102 and the RH lower fairing P/N 109-0324-25-304 in position and drill the rivet holes in the upper part of the FWD cap RH P/N 109-0329-72-185.
57. Touch-up the exposed areas of the repaired zones with primer and paint to restore the original aspect.
58. With reference to Figure 17, bond with sealant PROSEAL 890B2 or MC780 B-2 then attach with rivets the RH lower fairing P/N 109-0324-25-304. Make sure that that the drain holes in the fairing are not plugged by the sealant.
59. With reference to Figure 17, bond with sealant PROSEAL 890B2 or MC780 B-2 then attach with rivets the RH post lower fairing P/N 109-0324-30-102. Make sure that that the drain holes in the fairing are not plugged by the sealant.
60. In accordance with MM Paragraphs 07-30-1 or 07-30-2, lay down the helicopter.
61. Reinstall the cockpit/passenger doors caution system switch on the RH post centre fairing P/N 109-0324-29-102 using the related screws. Put the shims (if any) in their original position.
62. With reference to Figure 27, reinstall the LH post centre fairing P/N 109-0324-29-102 using the related attaching screws.
63. If originally installed, reinstall the sill-liner or apply the anti-slip paint on the upper side of the fairings P/N 109-0324-25-304 and 109-0324-30-102.
64. Reinstall the cockpit and passenger doors seals.
65. In accordance with MM Paragraphs 67-00-12 and 67-12-1, reinstall the following

components of the flight control system:

- Lateral cyclic control rod P/N 109-0032-01-1;
- Longitudinal cyclic control rod P/N 109-0032-03-1;
- Lateral cyclic lever P/N 109-0020-17-1;
- Lateral cyclic control rod P/N 109-0032-02-1.

66. In accordance with MM Paragraph 21-21-1, reinstall the air conditioning duct located inside the door lower sill.

67. With reference to Figure 14 and Figure 15, reinstall the lateral cyclic control rod assy P/N 109-0032-19-101 and the longitudinal cyclic control rod assy P/N 109-0032-07-01 as follows:

**CAUTION**

Apply the maximum care to prevent any damage to the control rod caused by rubbing with other parts of the helicopter.

67.1 Put the longitudinal control rod assy in position on interior of the right cabin post by inserting it from the top. Observe the correct sense and position of installation, as identified in previous Step 2.8.

67.2 With reference to Figure 15, attach the upper end of the longitudinal control rod to the lever using the bolt P/N AN174-12, one washer P/N AN960-PD416 (under the bolt head), one washer P/N AN960-PD416 under the nut, and the nut P/N MS17825-4. Torque the nut to 3.4 thru 4.5 Nm and install a new cotter pin P/N MS24665-153. If necessary, install one additional washer P/N AN960-PD416 under the nut to obtain the correct engagement of the nut.

67.3 With reference to Figure 15, attach the lower end of the longitudinal control rod to the lever using the bolt P/N AN174-12, one washer P/N AN960-PD416 (under the bolt head), one washer P/N AN960-PD416 under the nut, and the nut P/N MS17825-4. If required, move slightly cyclic control stick as necessary to allow the insertion of the bolt. Torque the nut to 3.4 thru 4.5 Nm and install a new cotter pin P/N MS24665-153. If necessary, install one additional washer P/N AN960-PD416 under the nut to obtain the correct engagement of the nut.

**CAUTION**

Apply the maximum care to prevent any damage to the control rod caused by rubbing with other parts of the helicopter.

- 67.4 Put the lateral control rod assy in position on interior of the right cabin post by inserting it from the top. Observe the correct sense and position of installation, as identified in previous Step 2.8.
- 67.5 With reference to Figure 14, attach the upper end of the lateral control rod to the lever using the bolt P/N AN174-12, one washer P/N AN960-PD416 (under the bolt head), one washer P/N AN960-PD416 under the nut, and the nut P/N MS17825-4. Torque the nut to 3.4 thru 4.5 Nm and install a new cotter pin P/N MS24665-153. If necessary, install one additional washer P/N AN960-PD416 under the nut to obtain the correct engagement of the nut.
- 67.6 With reference to Figure 14, attach the lower end of the lateral control rod) to the lever using the bolt P/N AN174-12, one washer P/N AN960-PD416 (under the bolt head), one washer P/N AN960-PD416 under the nut, and the nut P/N MS17825-4. If required, move slightly cyclic control stick as necessary to allow the insertion of the bolt. Torque the nut to 3.4 thru 4.5 Nm and install a new cotter pin P/N MS24665-153. If necessary, install one additional washer P/N AN960-PD416 under the nut to obtain the correct engagement of the nut.
- 67.7 Remove the masking tape that has been put on the rods to identify the direction of installation (ref. Step 2.8).
- 67.8 Perform a duplicate inspection of installation of the control rods. The duplicate inspection must include, but is not limited to, correct assembly, security, correct application of cotter pins, thread engagement and protrusion, and a functional check for complete range, freedom of movement and operation in correct sense.
68. To check that the Fixed Flight Component have been properly re-installed, get access to the cyclic control stick on the left side of the cockpit, and with hydraulic power supply at 1500 PSI perform the following Step of MM Paragraph 67-00-26, (ref. Figures 3 thru 10):
  - Disengage the spring P/N 109-0020-36 from the bracket;
  - Fully loosen the friction control;
  - Step B;
  - Step C. If rigging pins do not fit, apply MM Paragraph 67-00-26;
  - Engage the spring P/N 109-0020-36 on bracket
  - Step H;
  - Do the adjustment of the fixed frictions of the cyclic control system.
69. Perform an operational test of the cyclic control system to make sure that the control linkages move freely.
70. Reinstall all the access panels you have removed to perform the repair.
71. Panel P/N 109-0320-90-8, removed at Step 7, can be reused after removing thoroughly

any trace of sealant using a plastic scraper and a cloth moistened with solvent MIL-PRF-680 TY II.

72. Reinstall the support panels located under the pilot and co-pilot seat. Reinstall also the centre panel located between the seats and any control located on it (e.g. friction knob, cargo hook release handle).
73. Reinstall the access door P/N 109-0325-73-335 on the upper part of the fuselage, over the door post, and move the platform away from helicopter.
74. Reinstall the access panel P/N 109-0329-72-307 or 109-0329-72-419.
75. In accordance with MM Paragraph 21-21-1, reinstall the air distribution duct P/N 109-0710-32-106 on the door post.
76. With reference to the pertinent MM Paragraph, reinstall all the items of equipment/furnishing that were removed to gain access to work area.
77. If originally installed, in accordance with MM Paragraph 25-21-12, reinstall the forward passenger seat.
78. In accordance with MM Paragraph 25-11-9, reinstall the pilot and co-pilot seat.
79. If originally installed, in accordance with MM Paragraphs 25-81-7 and 25-81-9, reinstall the cockpit and passenger compartment soundproofing panels or the moquette lining.
80. In accordance with MM Paragraph 52-11-9, reinstall the pilot and co-pilot doors and close the passenger compartment doors.
81. In accordance with MM Paragraph 52-71-6, perform an operational test of the cockpit/passenger doors caution system.
82. In accordance with weight and balance changes, update the Chart A (see Rotorcraft Flight Manual, Part II, section 6).
83. Return the helicopter to a ready to flight condition and record for compliance with Part III of this Service Bulletin on the helicopter logbook.
84. Gain access to My Communications section on Leonardo WebPortal and compile the "Service Bulletin Application Communication".

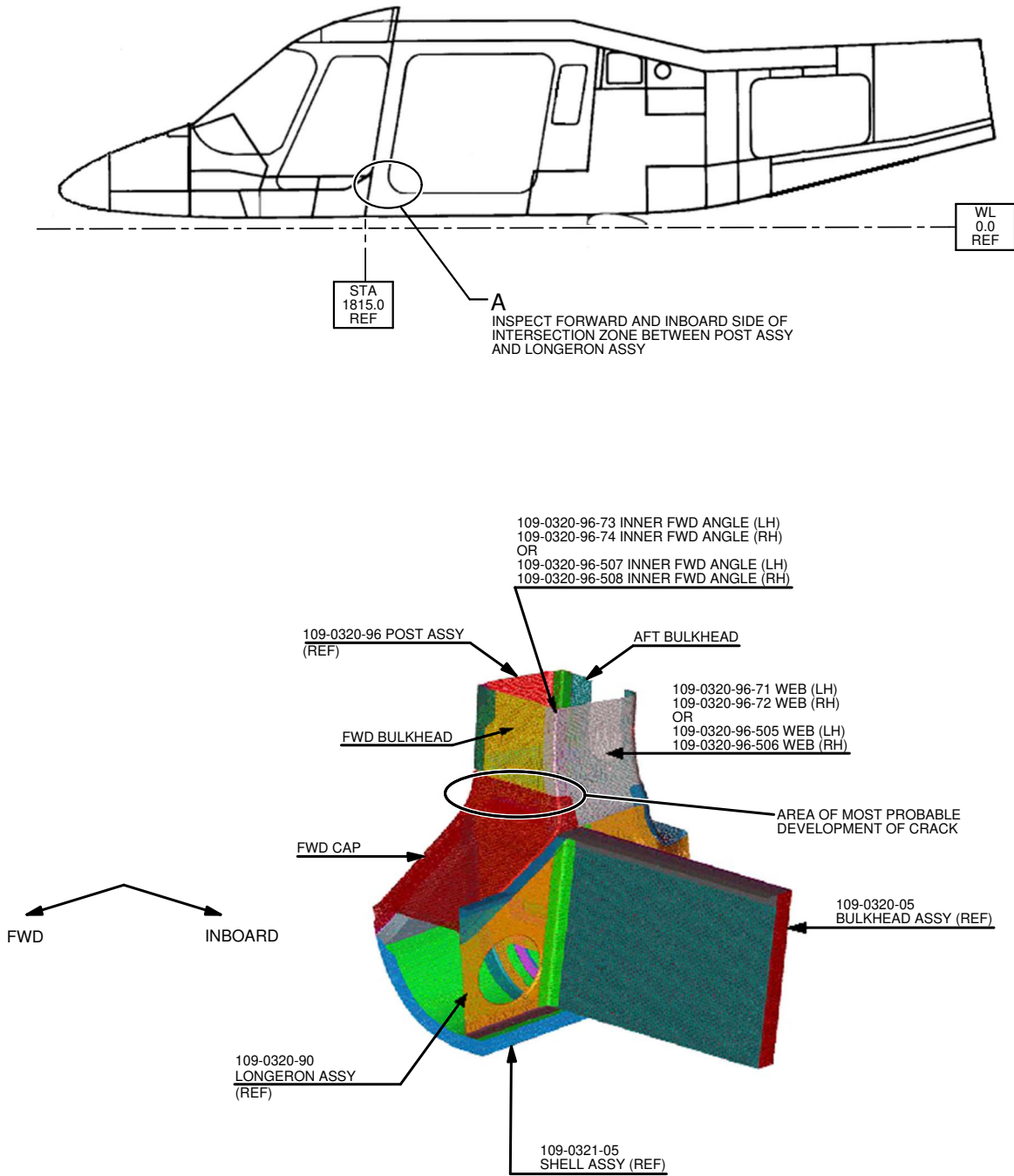
As an alternative, send the attached compliance form to the following mail box:

[engineering.support.lhd@leonardo.com](mailto:engineering.support.lhd@leonardo.com)

and (for North, Central and South America) also to:

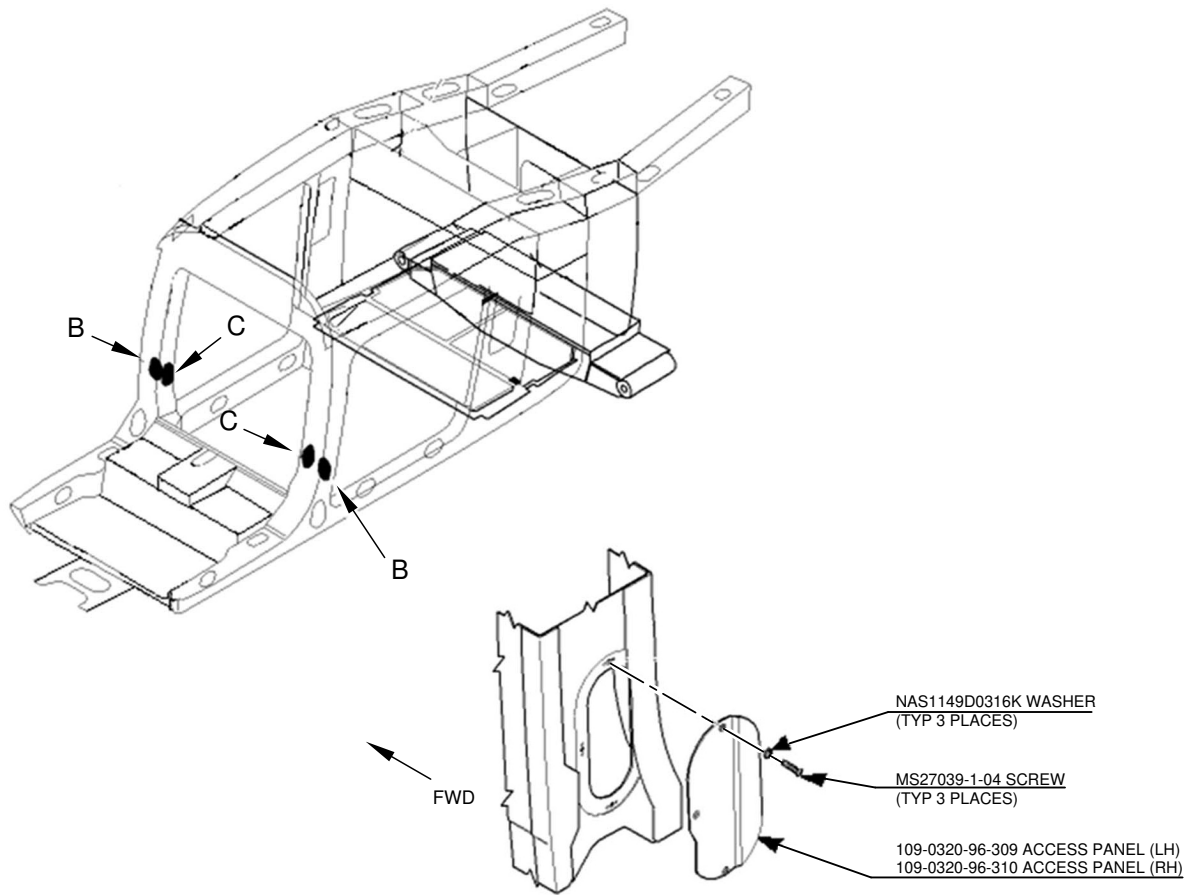
[AWPC.Engineering.Support@leonardocompany.us](mailto:AWPC.Engineering.Support@leonardocompany.us)





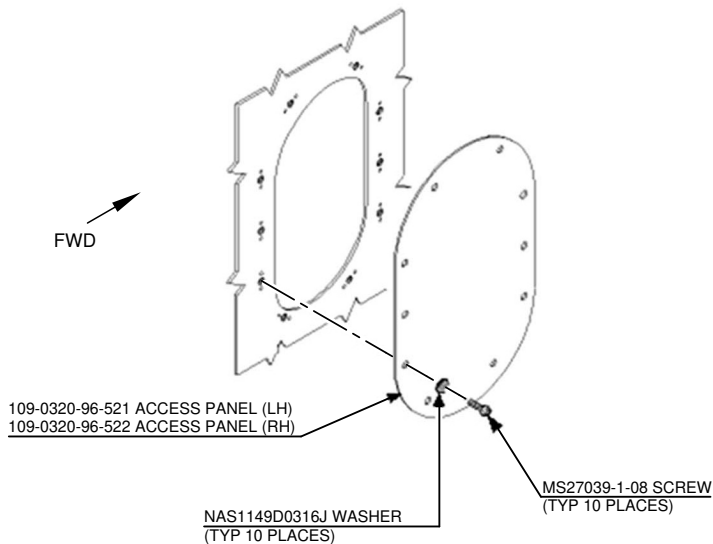
**DETAIL A**  
(RIGHT SIDE SHOWN TYP LEFT SIDE)  
STRUCTURES AND SYSTEMS ARE PARTIALLY  
OMITTED FOR BETTER CLARITY PURPOSE

**Figure 1**



**DETAIL B**

STRUCTURES AND SYSTEMS ARE PARTIALLY OMITTED FOR BETTER CLARITY PURPOSE

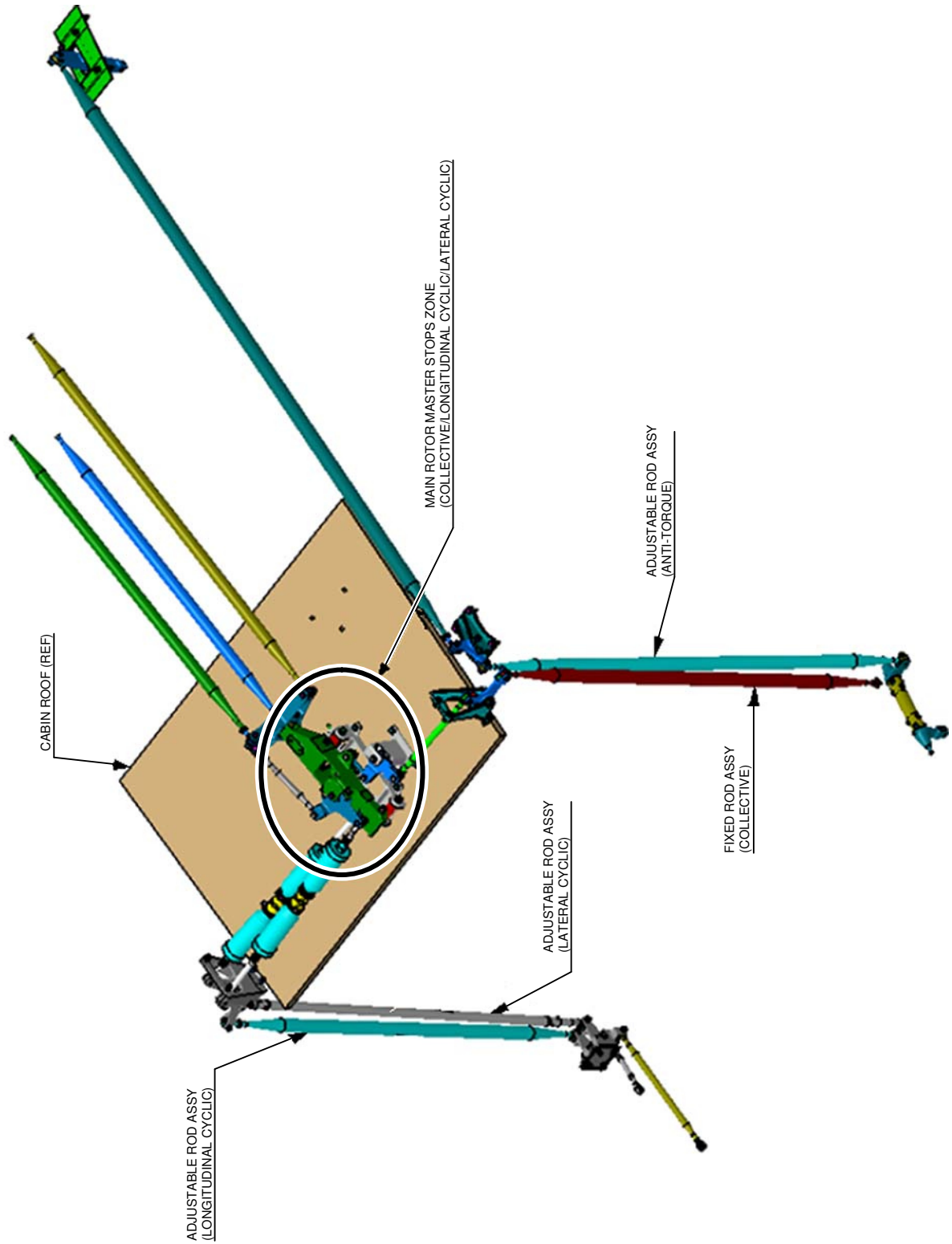


**DETAIL C**

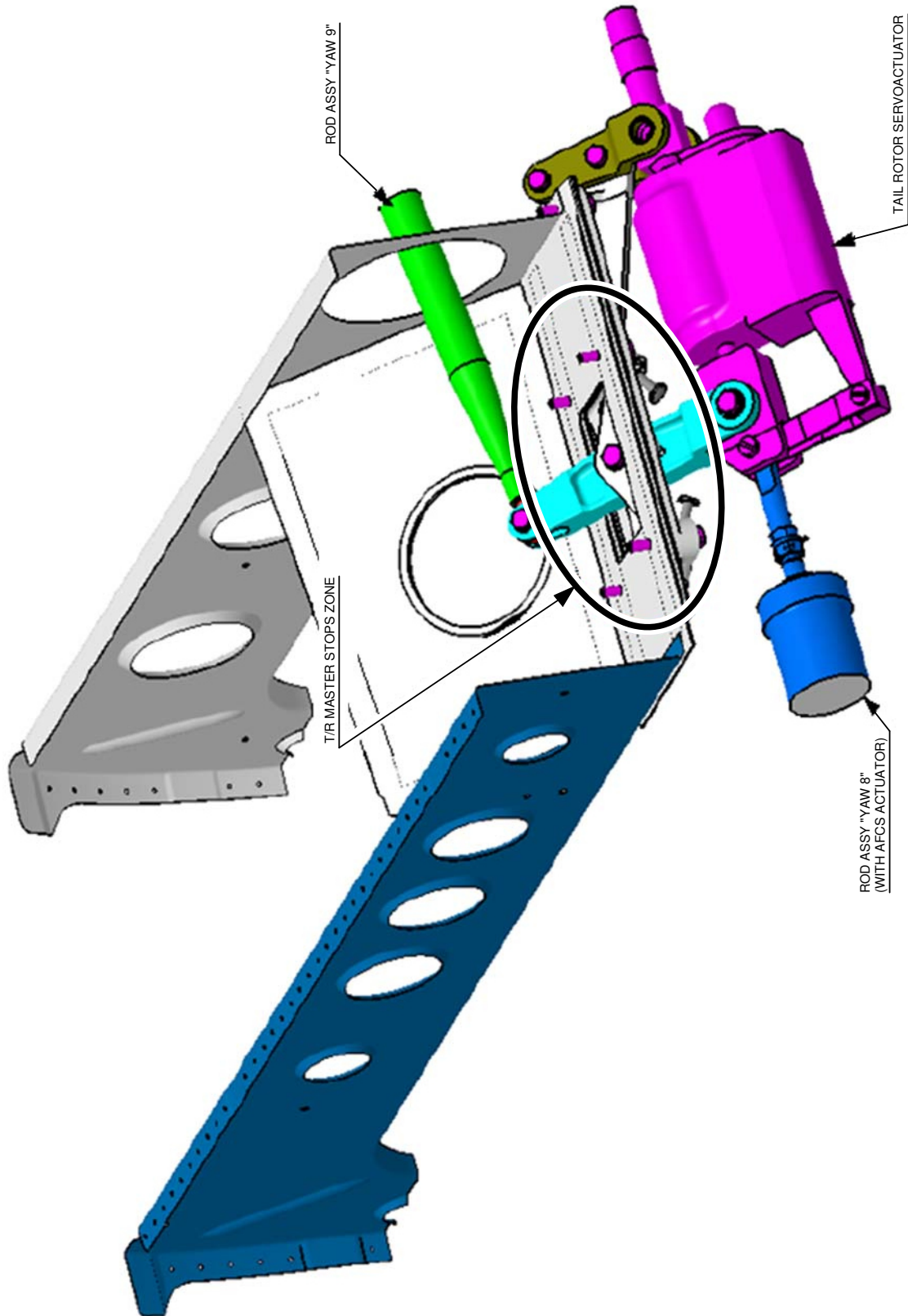
STRUCTURES AND SYSTEMS ARE PARTIALLY OMITTED FOR BETTER CLARITY PURPOSE

**Figure 2**

S.B. N°109EP-179 ALERT  
DATE: July 21, 2022  
REVISION: A - August 24, 2023

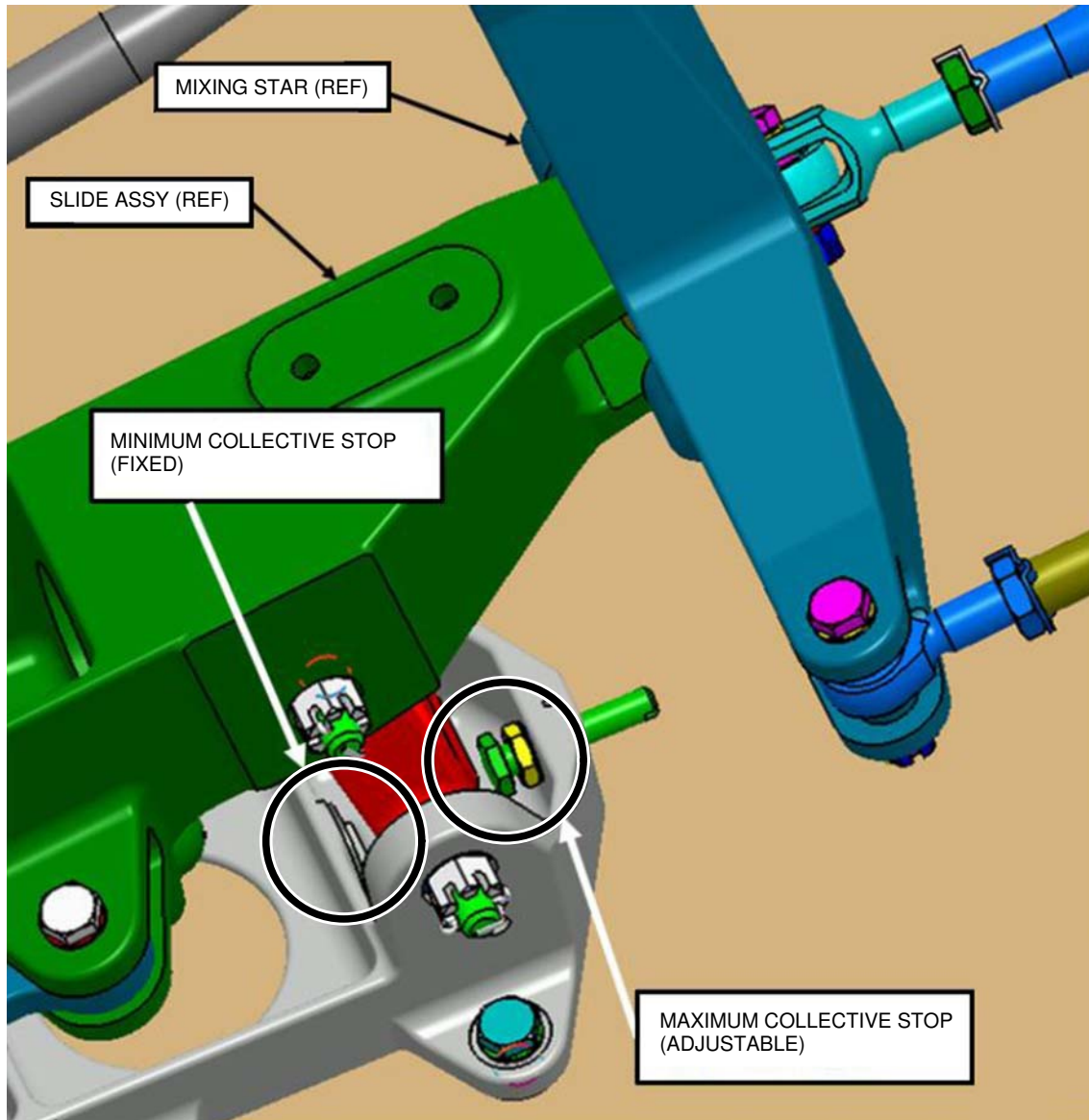


**Figure 3**

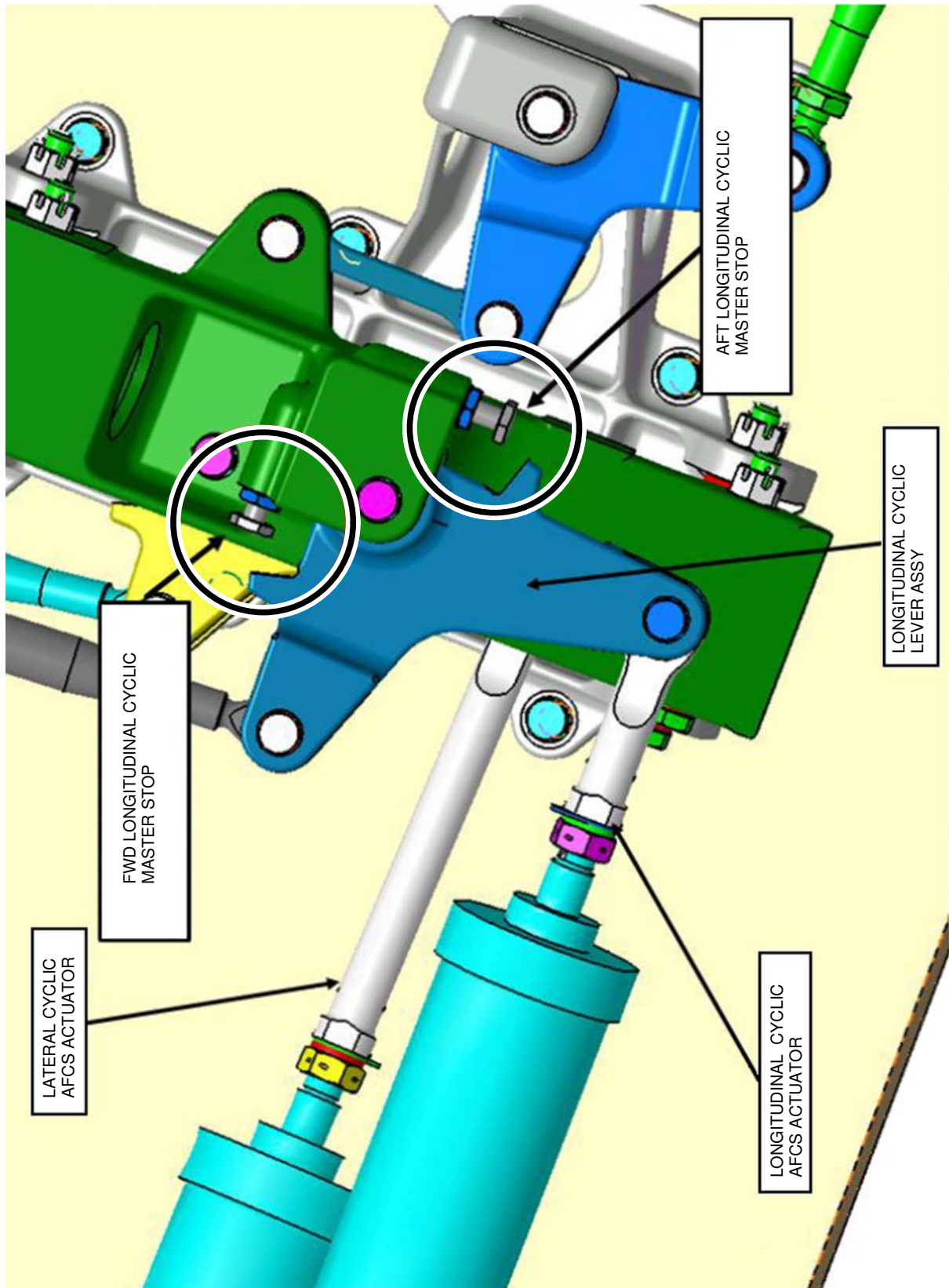


**Figure 4**

S.B. N°109EP-179 ALERT  
DATE: July 21, 2022  
REVISION: A - August 24, 2023



**Figure 5**



**Figure 6**

S.B. N°109EP-179 ALERT  
DATE: July 21, 2022  
REVISION: A - August 24, 2023

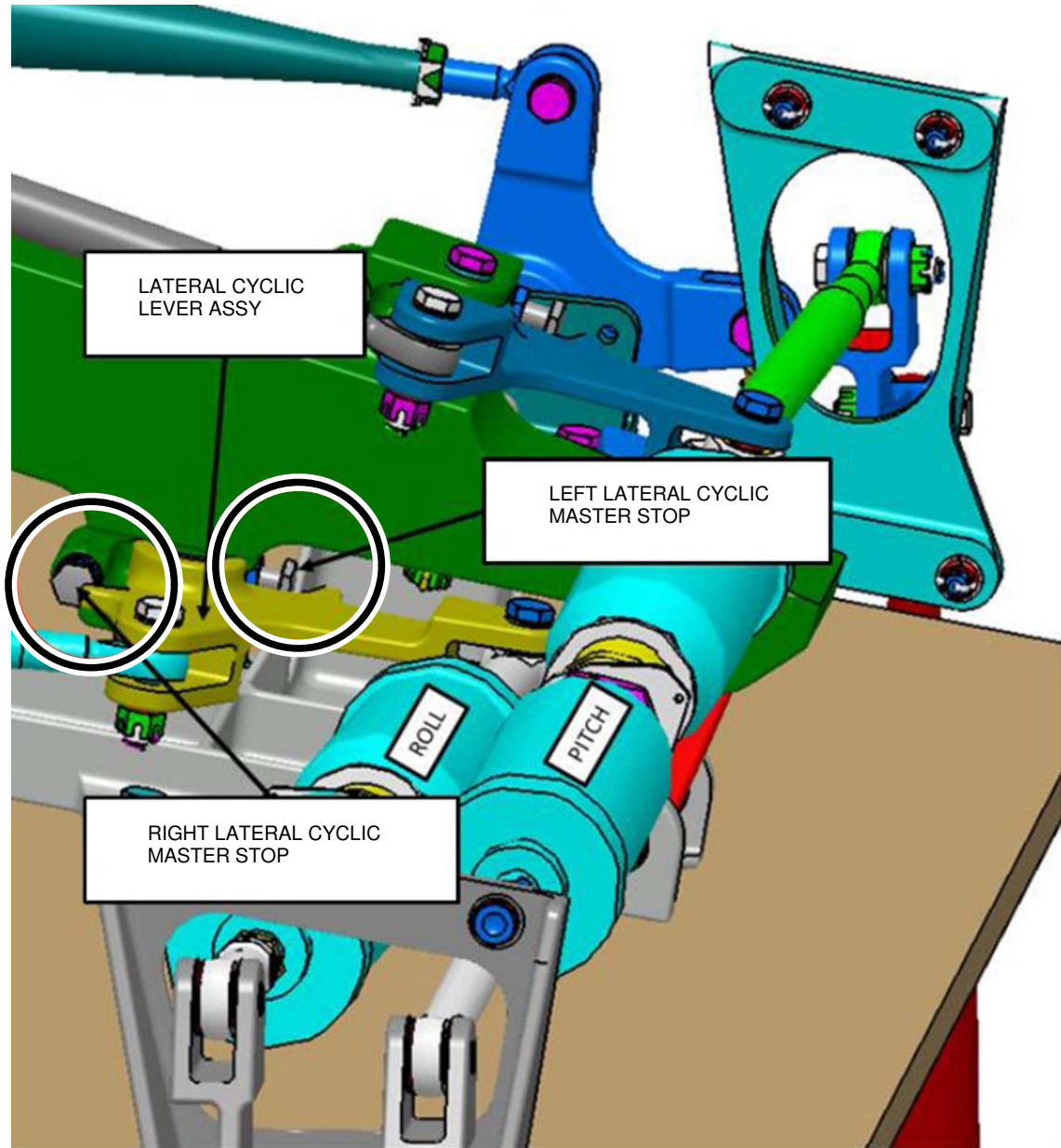
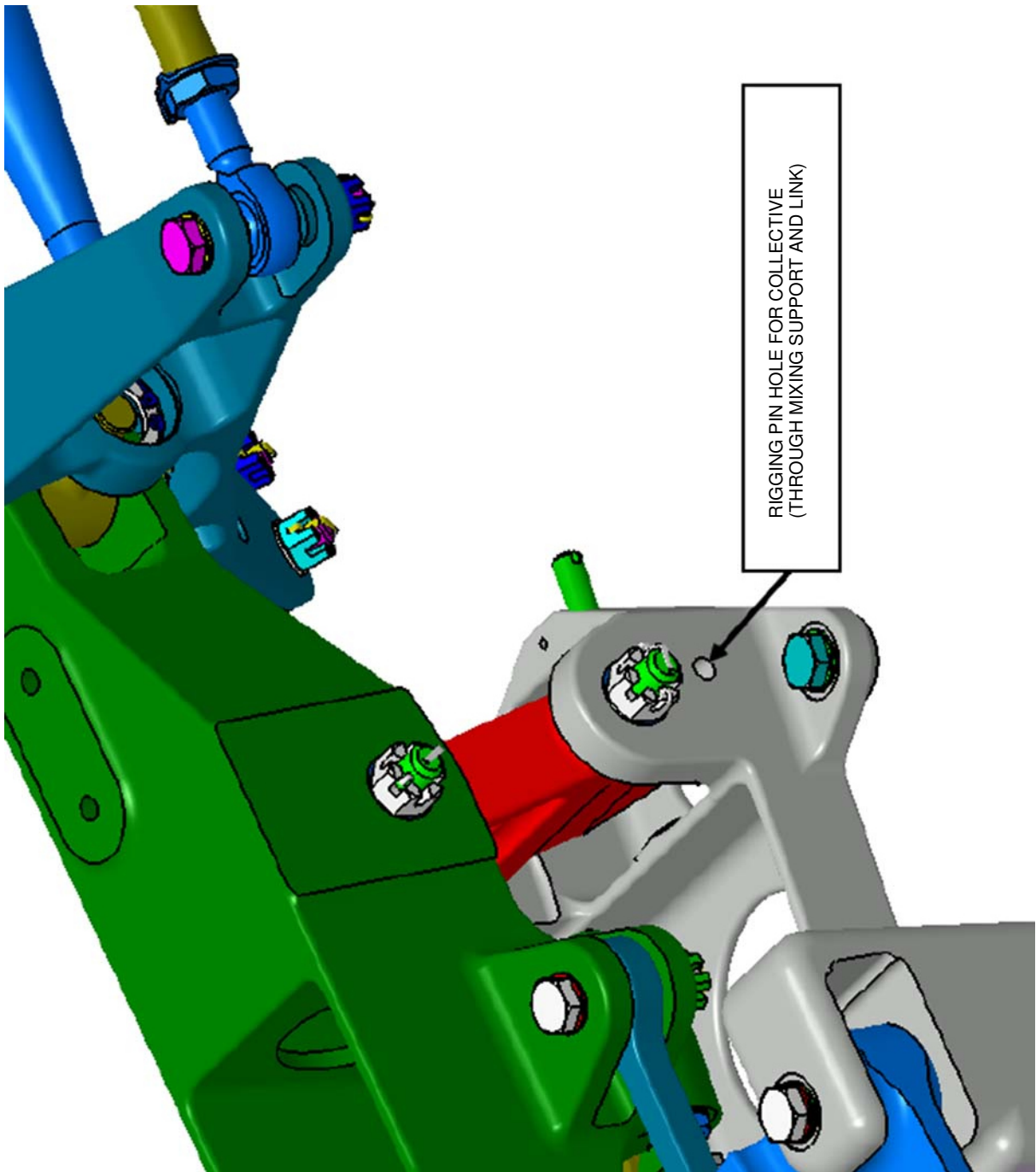


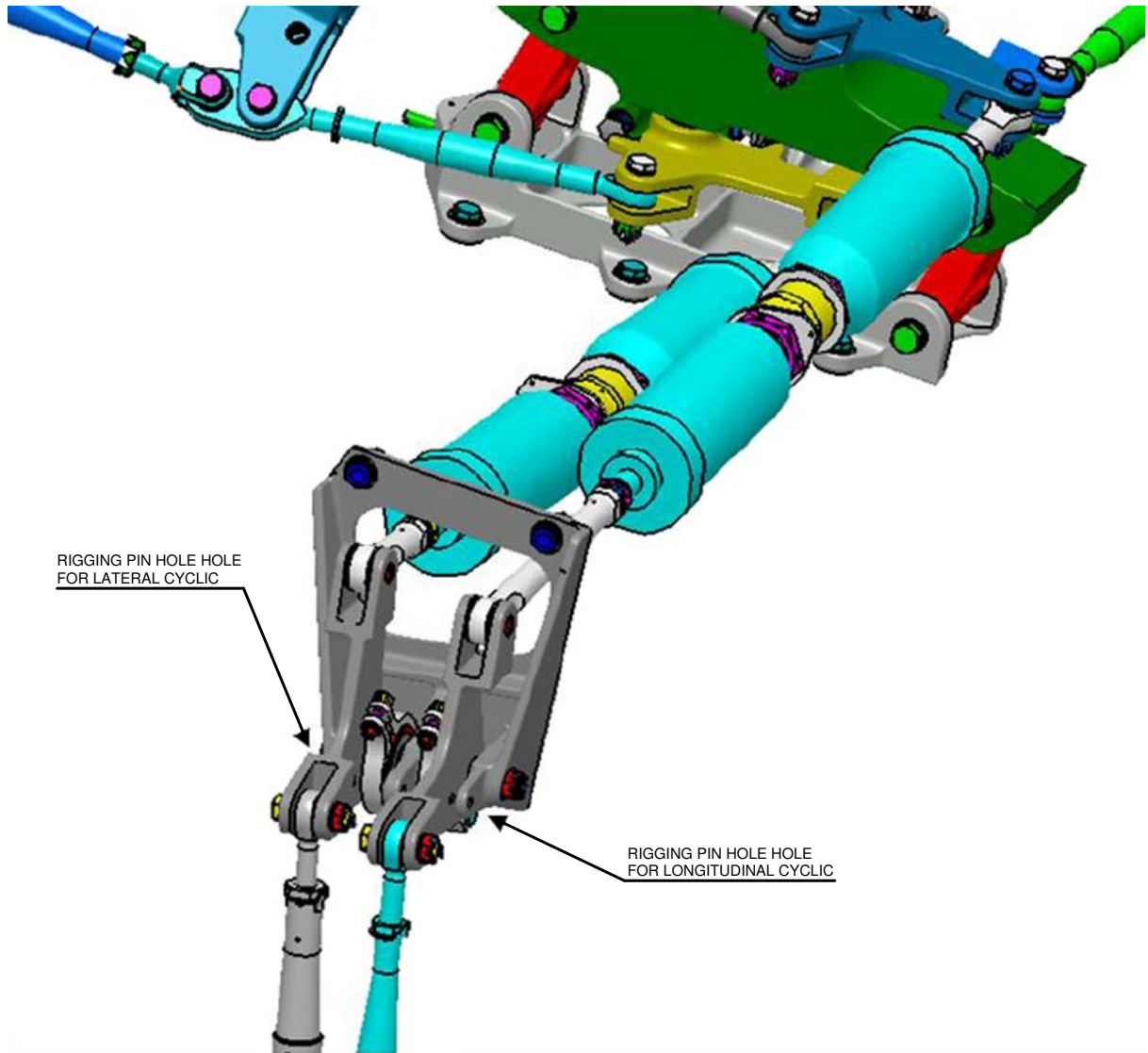
Figure 7



**Figure 8**

S.B. N°109EP-179 ALERT  
DATE: July 21, 2022  
REVISION: A - August 24, 2023





**Figure 9**

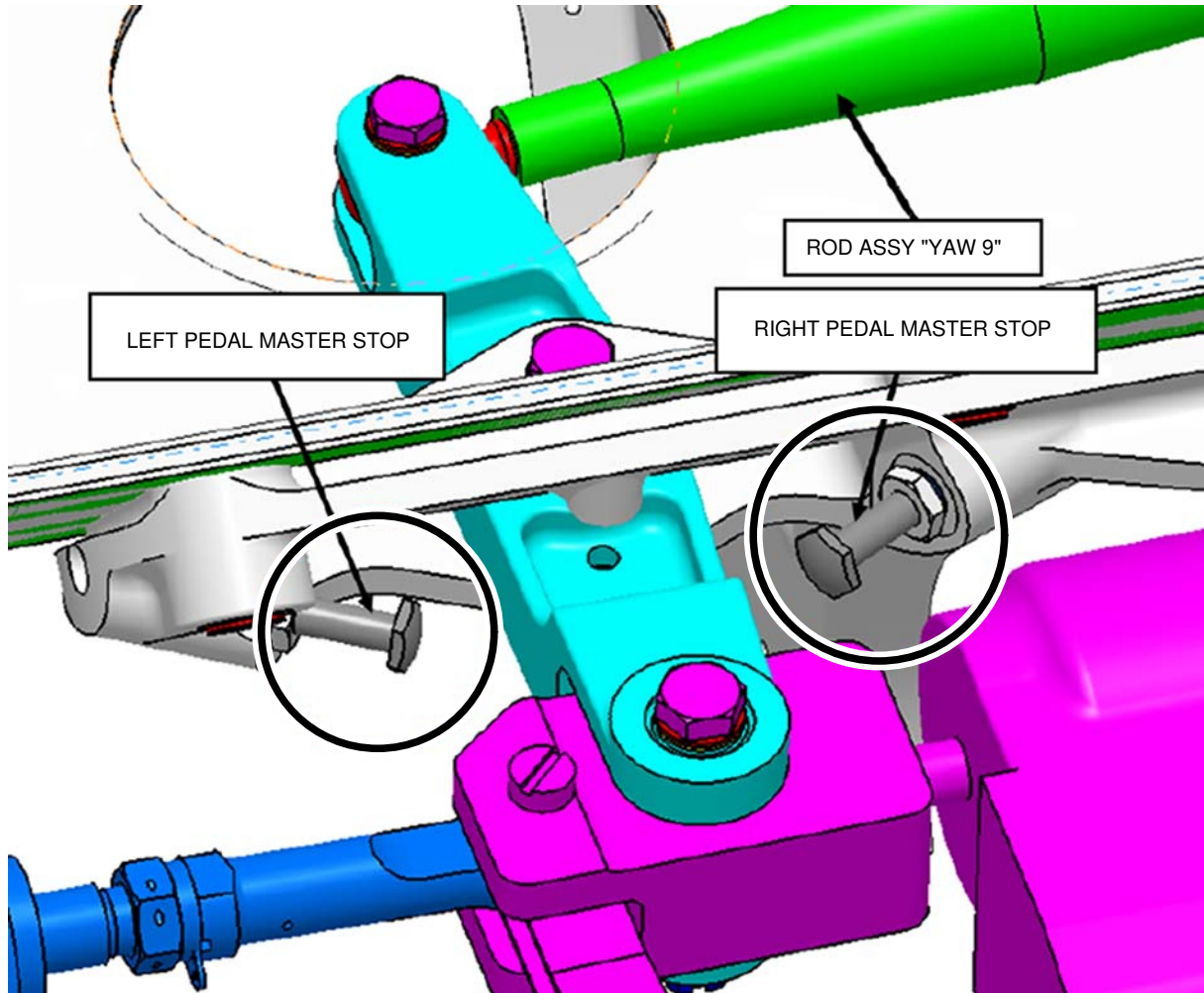
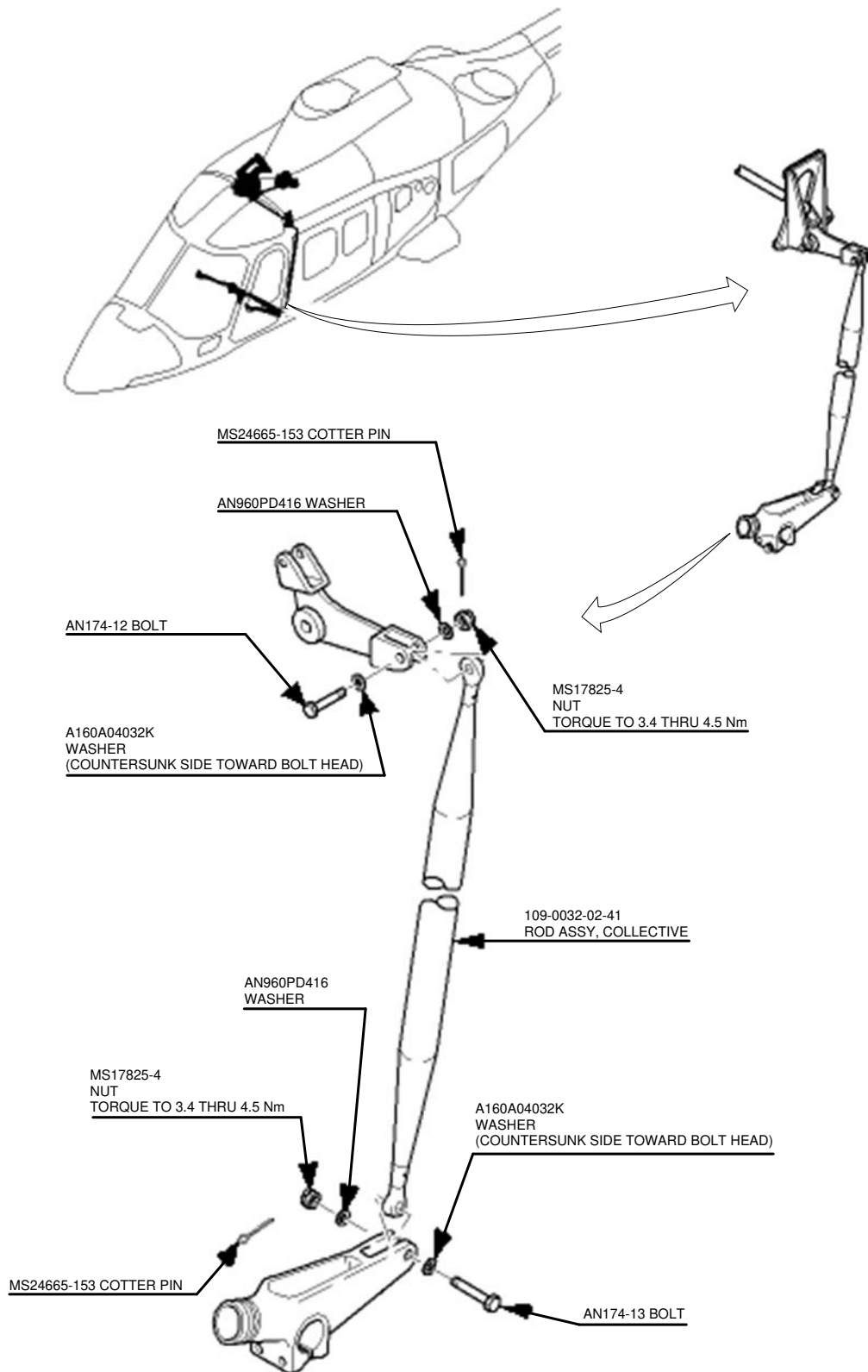
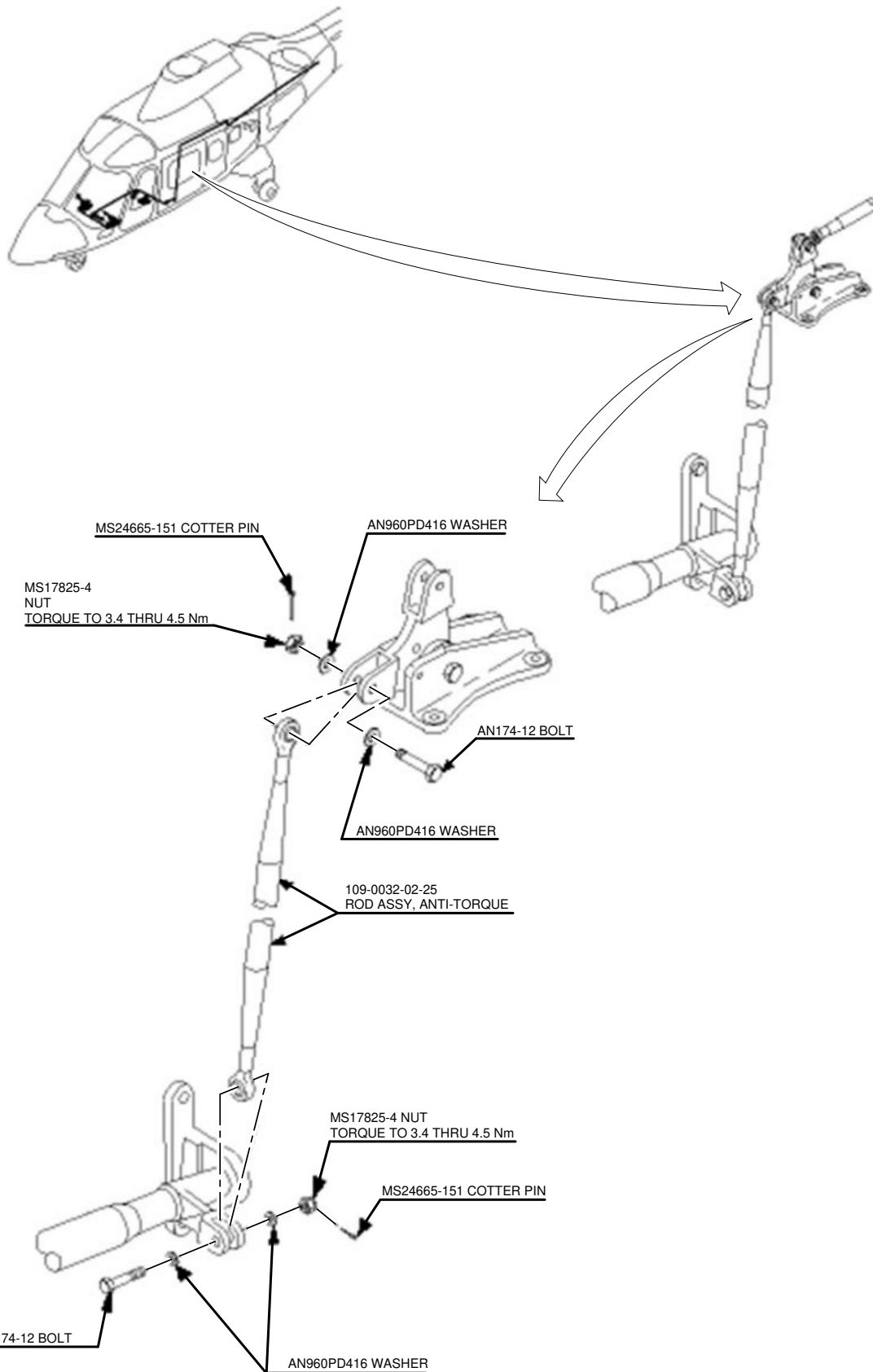


Figure 10

S.B. N°109EP-179 ALERT  
DATE: July 21, 2022  
REVISION: A - August 24, 2023

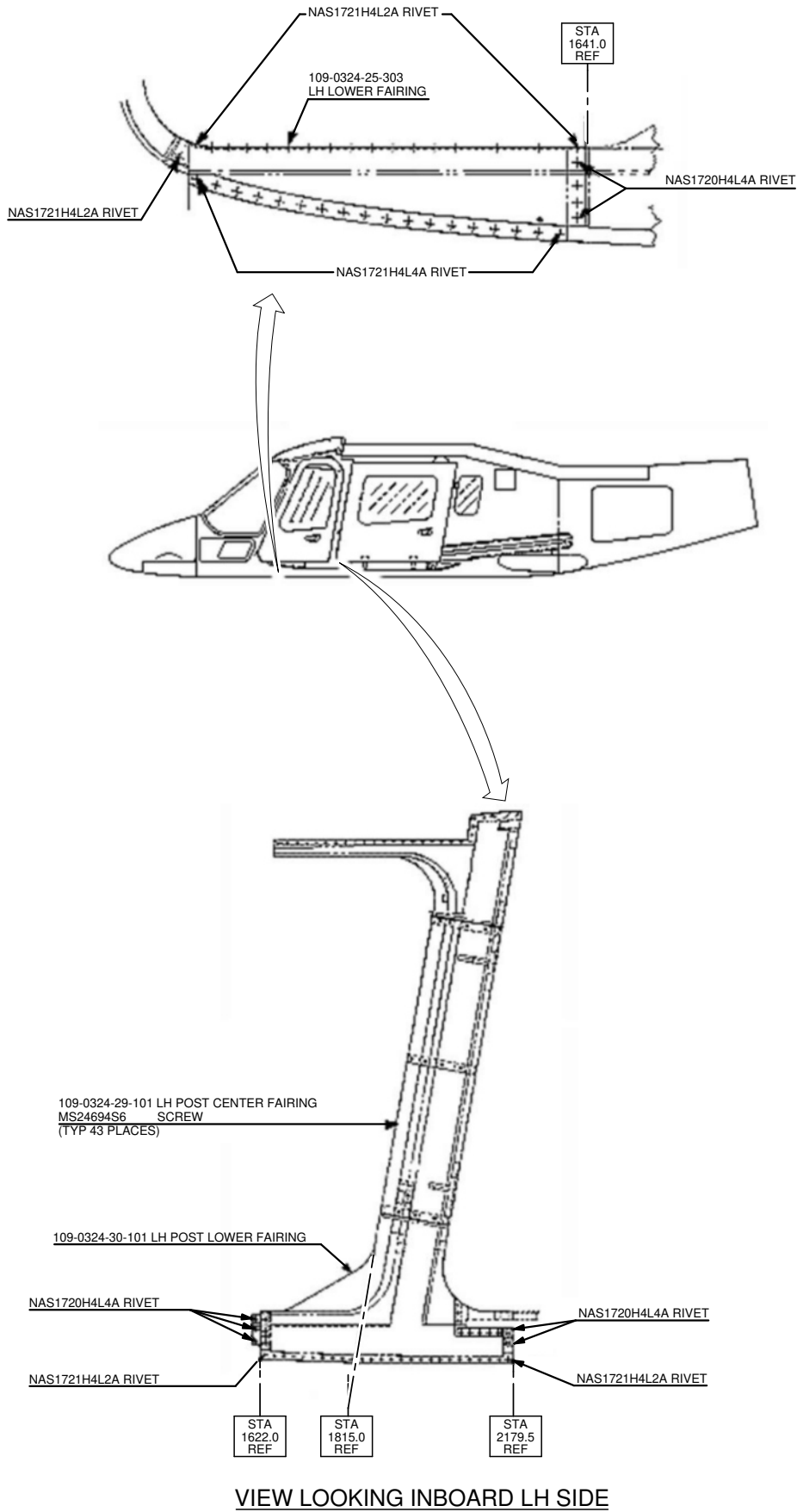


**Figure 11**

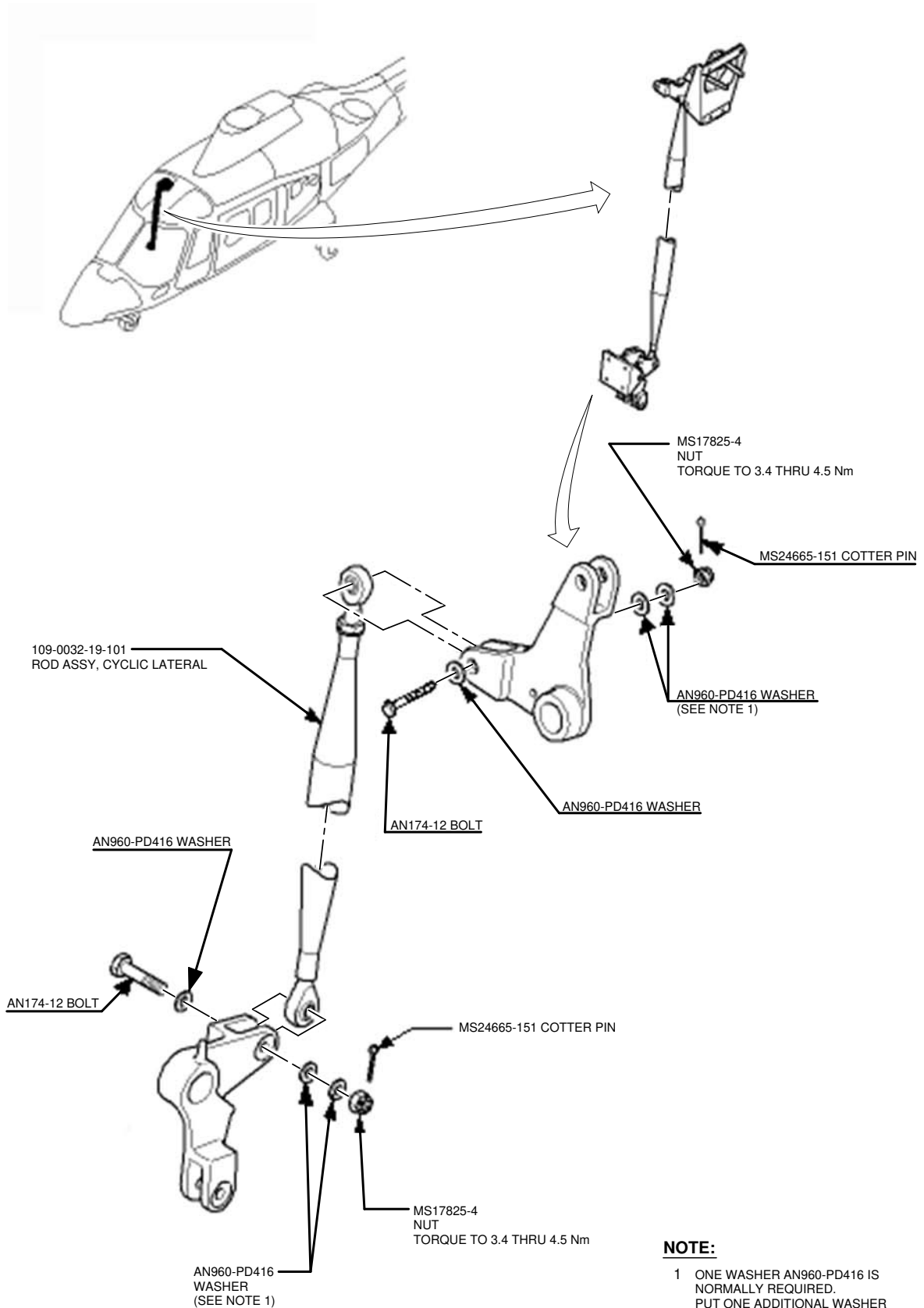


**Figure 12**

S.B. N°109EP-179 ALERT  
DATE: July 21, 2022  
REVISION: A - August 24, 2023

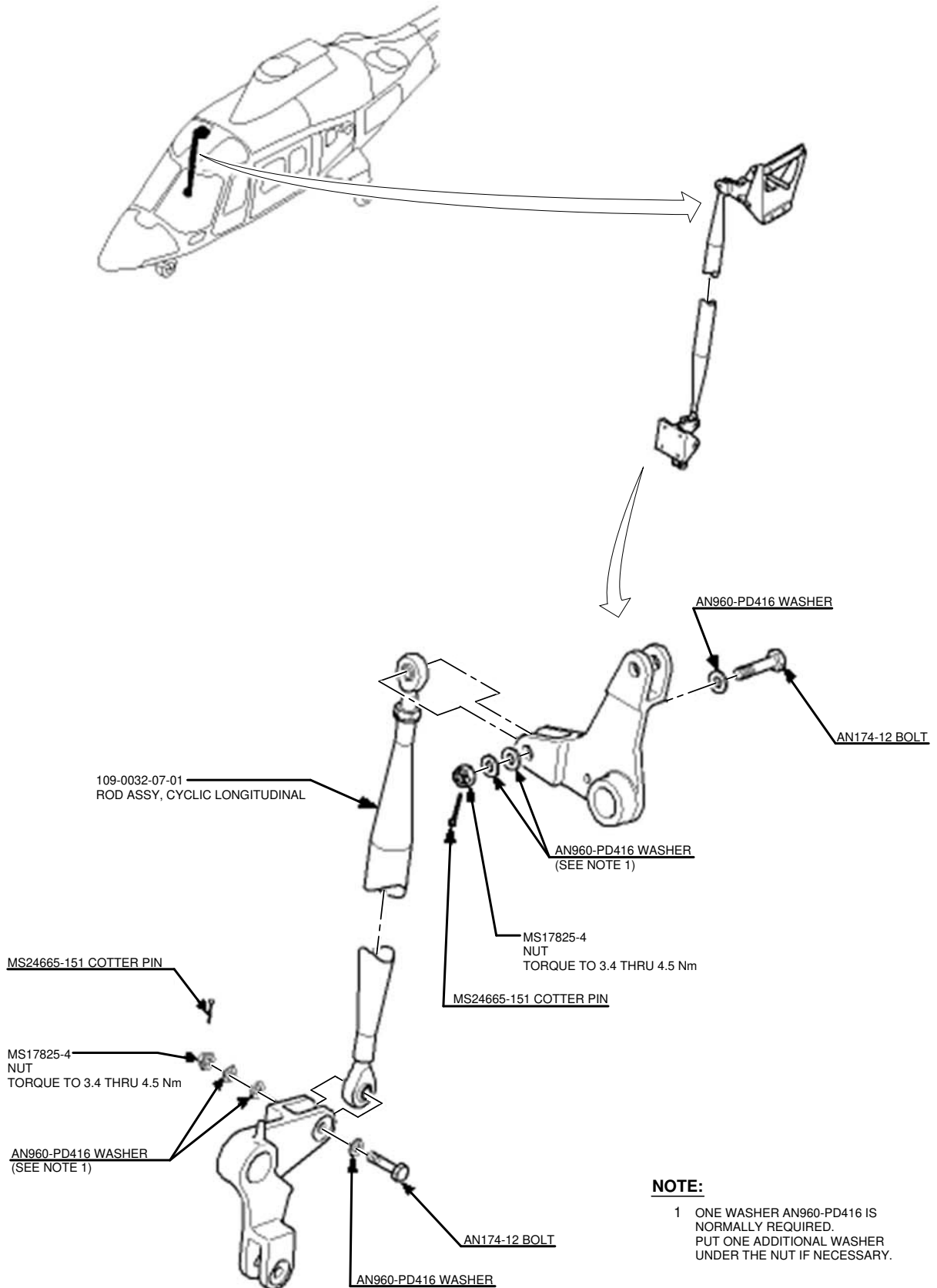


**Figure 13**

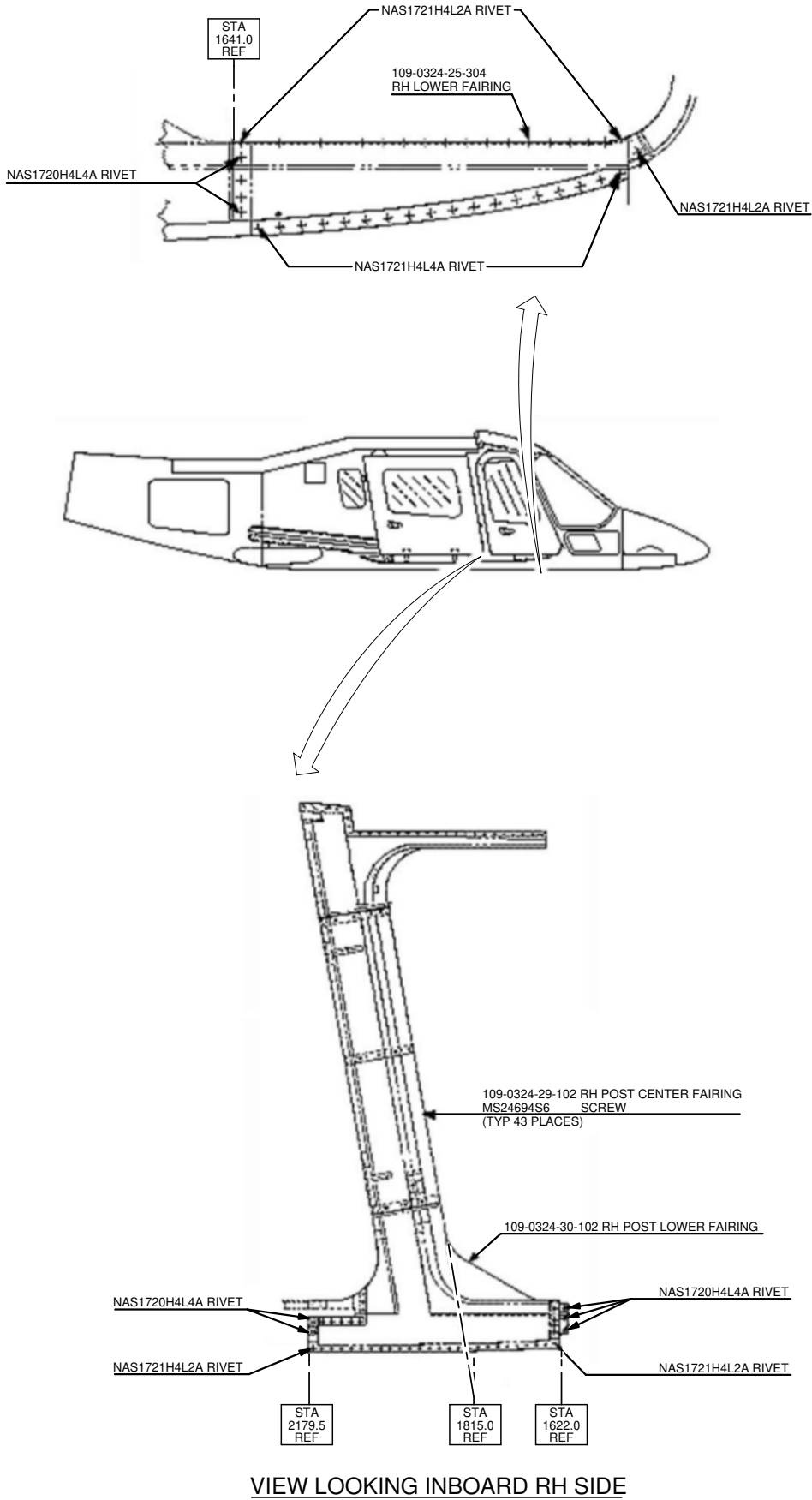


**Figure 14**

S.B. N°109EP-179 ALERT  
DATE: July 21, 2022  
REVISION: A - August 24, 2023



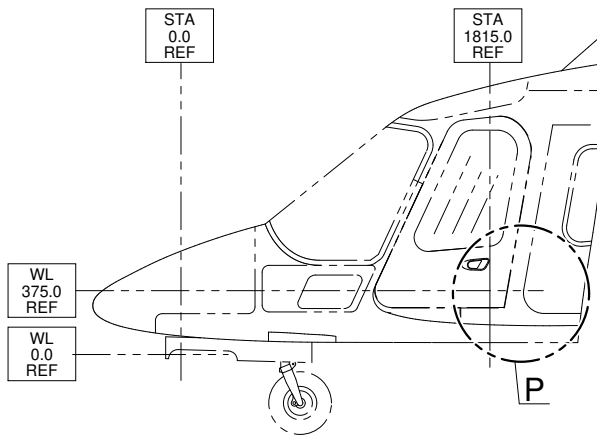
**Figure 15**



**Figure 16**

S.B. N°109EP-179 ALERT  
DATE: July 21, 2022  
REVISION: A - August 24, 2023





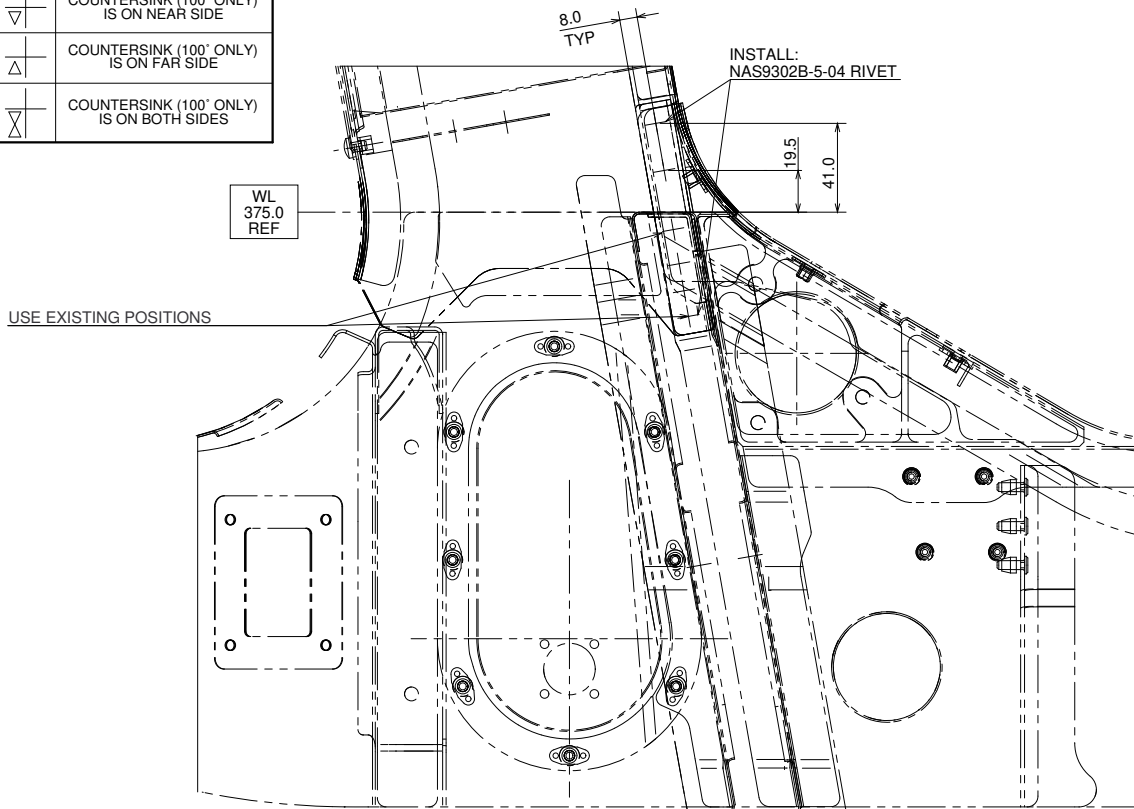
**109G5330R01-301**  
**LATERAL MOUNTING REINFORCEMENT**  
**INSTALLATION LH (SHOWN)**

**109G5330R01-302**  
**LATERAL MOUNTING REINFORCEMENT**  
**INSTALLATION RH (OPPOSITE)**

**109G5330R01-303**  
**ANGLE REPAIR INSTALLATION LH**  
**(SHOWN)**

**109G5330R01-304**  
**ANGLE REPAIR INSTALLATION RH**  
**(OPPOSITE)**

RIVET REFERENCE TABLE	
REF. N°	RIVET P/N
●01	MS20426AD5
●02	MS20470E5
●03	MS20470AD5
N	PRE-FORMED HEAD IS ON NEAR SIDE
F	PRE-FORMED HEAD IS ON FAR SIDE
▽	COUNTERSINK (100° ONLY) IS ON NEAR SIDE
△	COUNTERSINK (100° ONLY) IS ON FAR SIDE
⊗	COUNTERSINK (100° ONLY) IS ON BOTH SIDES



**VIEW LOOKING OUTBOARD**  
 (LEFT SIDE SHOWN TYP RIGHT SIDE EXCEPT AS SHOWN)  
 STRUCTURES AND SYSTEMS ARE PARTIALLY  
 OMITTED FOR BETTER CLARITY PURPOSE

**Figure 17**

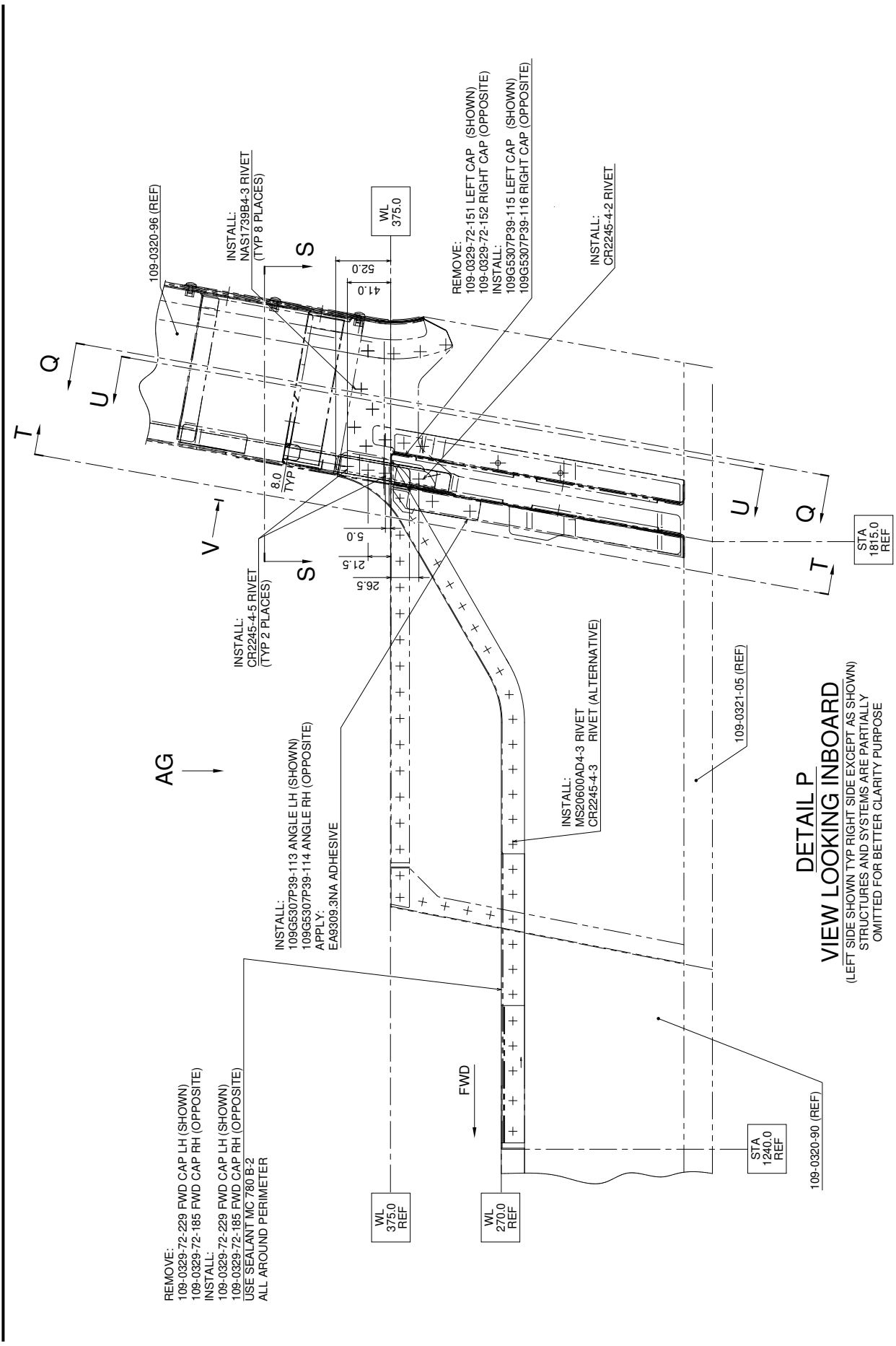
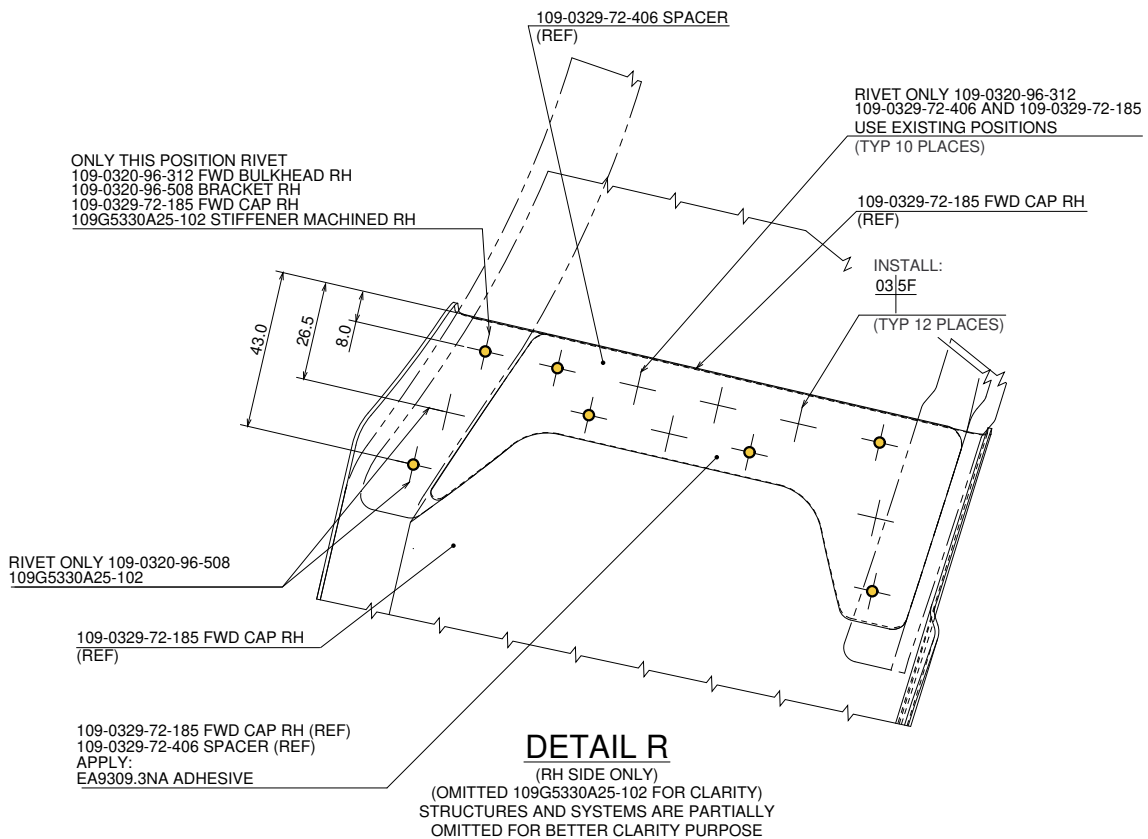
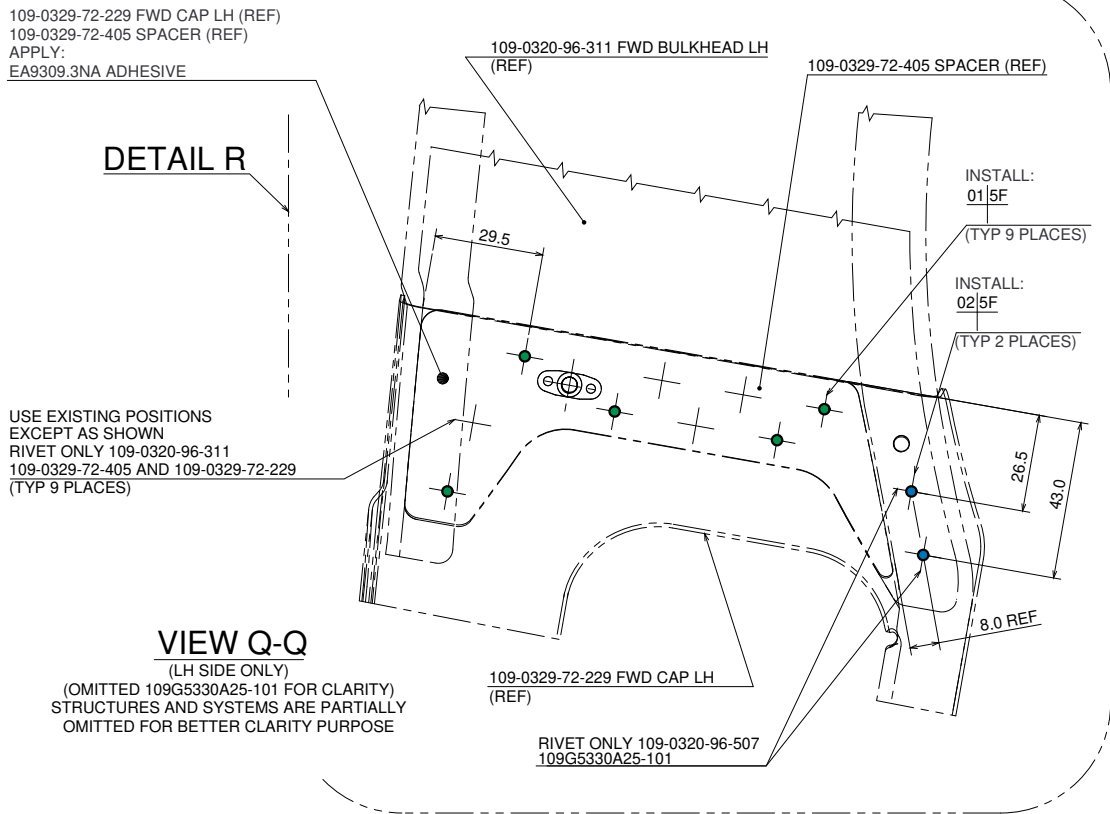
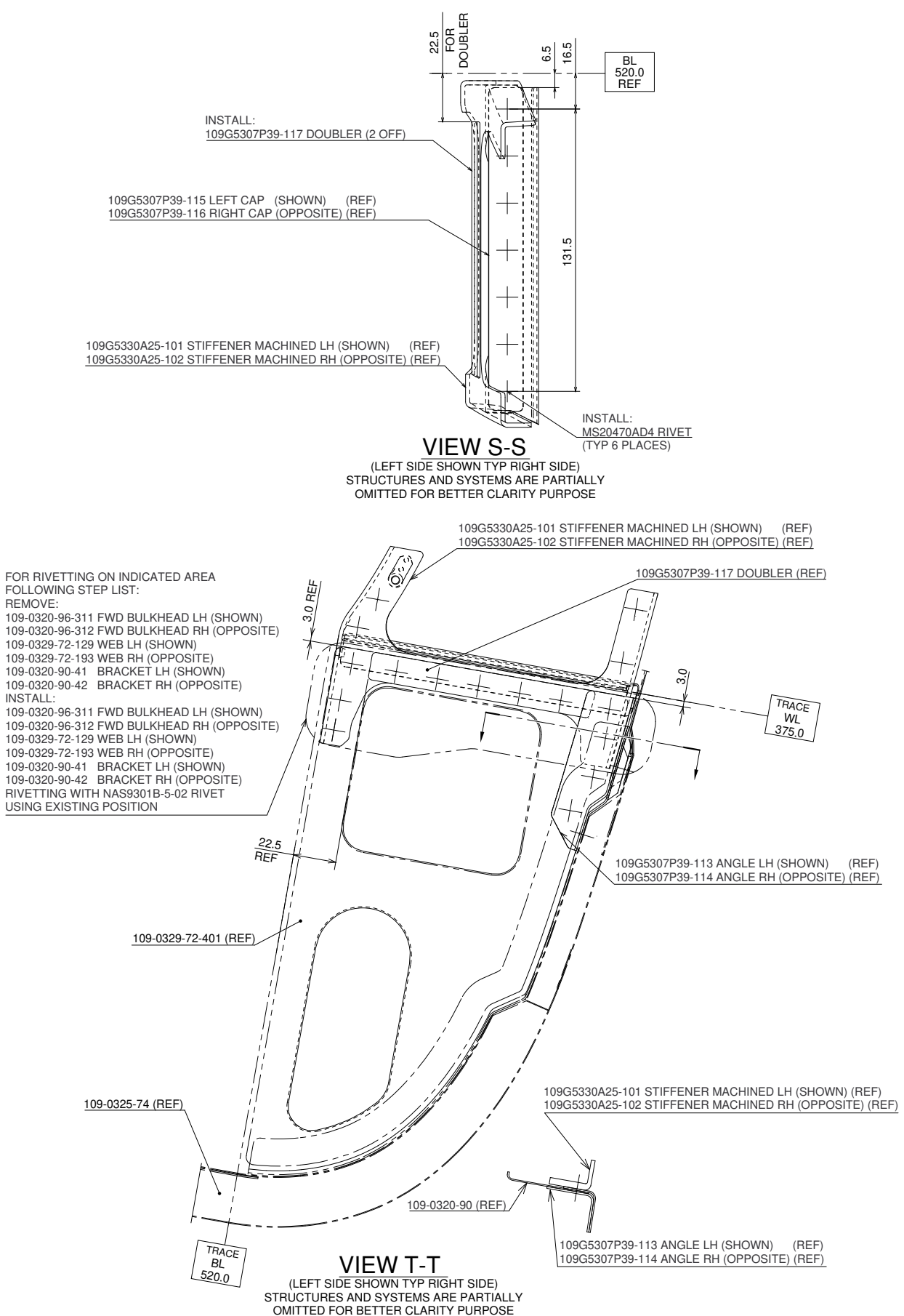


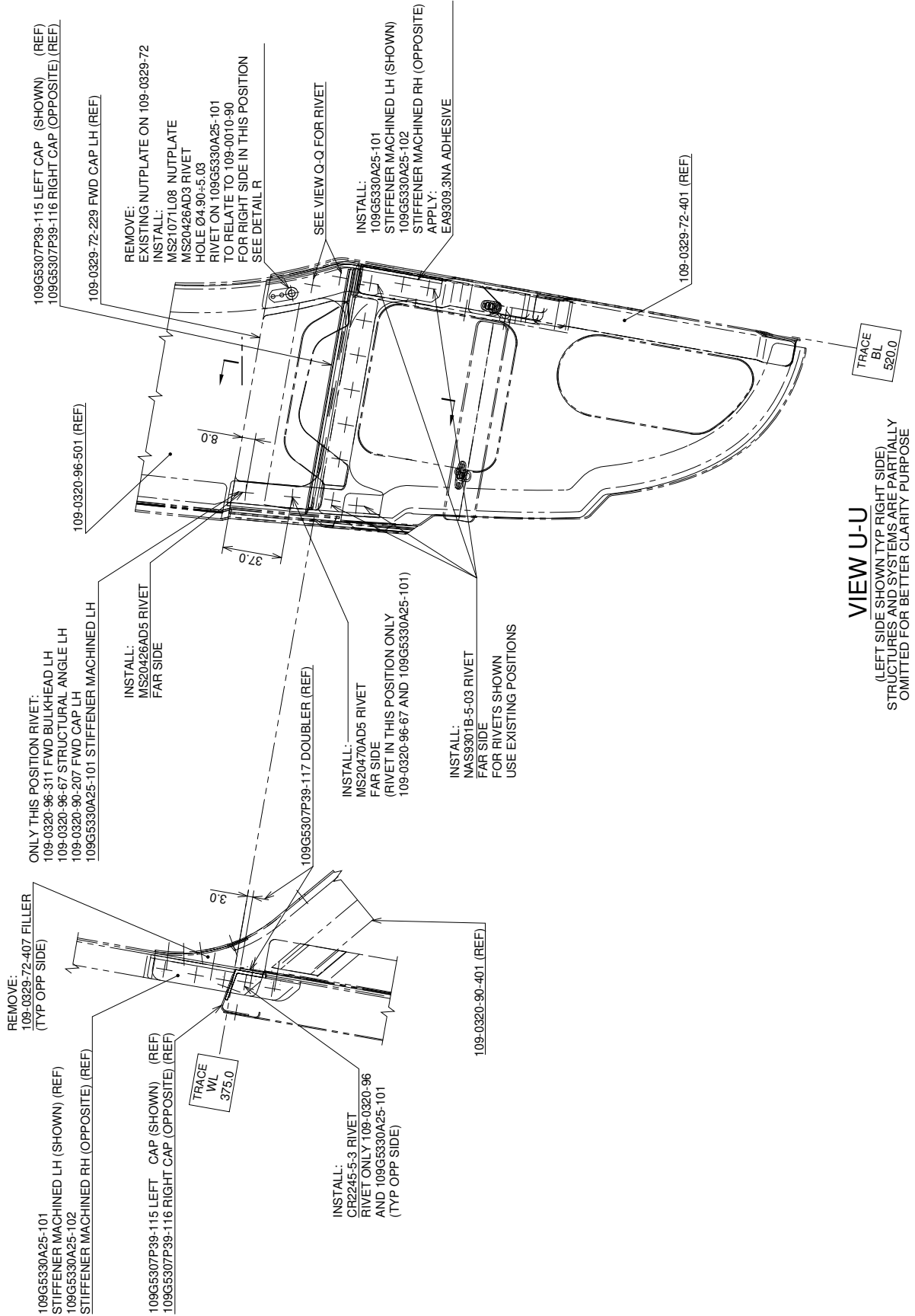
Figure 18



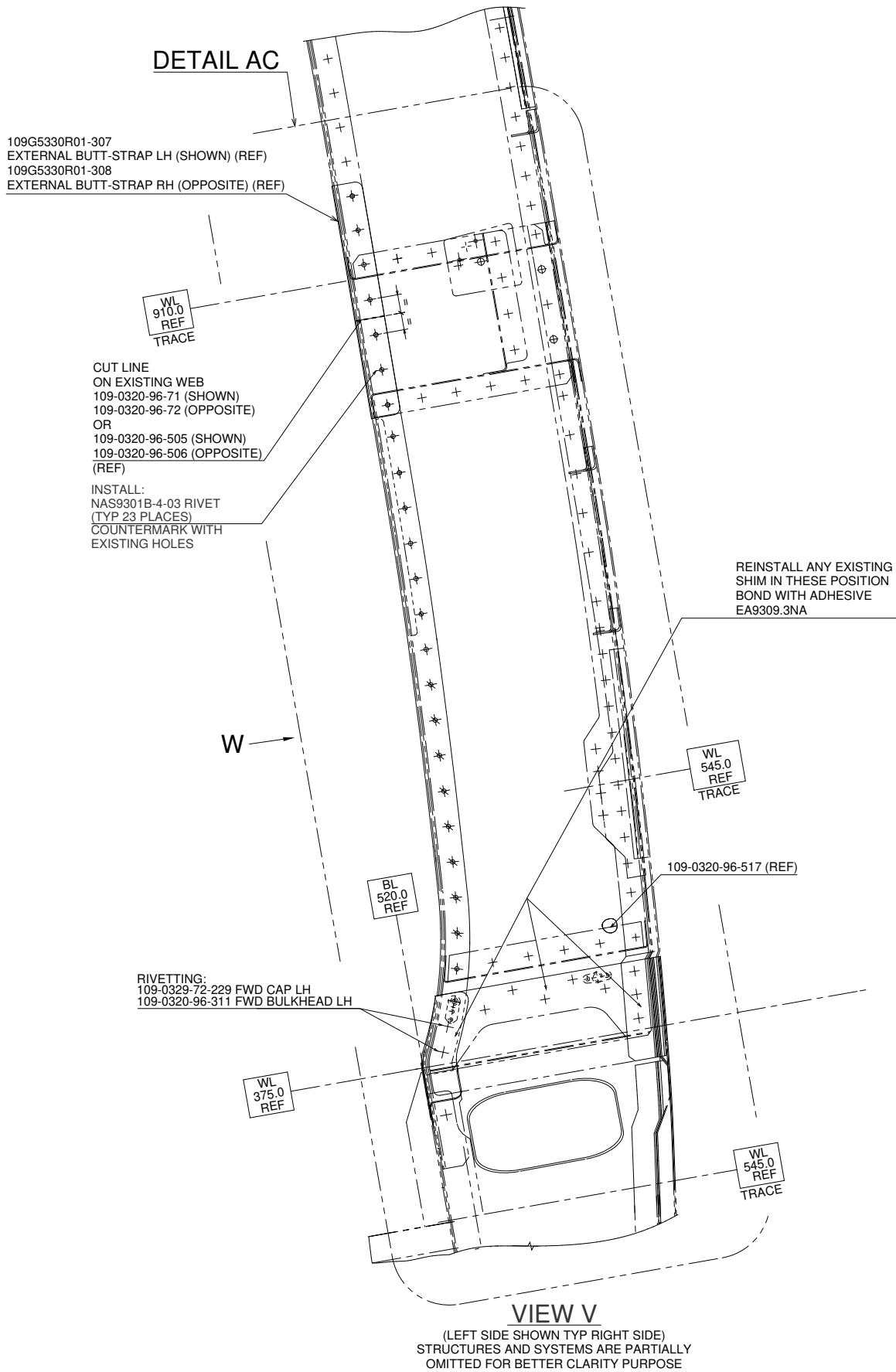
**Figure 19**



**Figure 20**



**Figure 21**



**Figure 22**

S.B. N°109EP-179 ALERT  
DATE: July 21, 2022  
REVISION: A - August 24, 2023

INSTALL:  
109G5330R01-307 EXTERNAL BUTT STRAP LH (SHOWN)  
109G5330R01-308 EXTERNAL BUTT STRAP RH (OPPOSITE)  
APPLY:  
EA9309.3NA ADHESIVE  
USE SEALANT MC 780 B-2  
ALL AROUND PERIMETER

INSTALL:  
NAS9307M-4-02 RIVET (11 OFF)  
COUNTERMARK WITH  
EXISTING HOLES

INSTALL:  
NAS9307M-4-03 RIVET  
COUNTERMARK WITH  
EXISTING HOLES  
CUT LINE  
ON EXISTING WEB  
109-0320-96-71 (SHOWN)  
109-0320-96-72 (OPPOSITE)  
OR  
109-0320-96-505 (SHOWN)  
109-0320-96-506 (OPPOSITE)  
(REF)

INSTALL:  
NAS9307M-4-03 RIVET (6 OFF)  
COUNTERMARK WITH  
EXISTING HOLES

WL  
910.0  
REF  
AB

INSTALL:  
NAS9301B-4-03 RIVET  
COUNTERMARK WITH  
EXISTING HOLES

INSTALL:  
NAS9307M-4-02 RIVET (16 OFF)

INSTALL:  
MS20426AD4 RIVET  
(TYP 4 PLACES)

INSTALL:  
MS21069L3 NUTPLATE  
MS20426AD3 RIVET (2 OFF)  
(TYP 8 PLACES)

INSTALL:  
109G5330R01-309  
INTERNAL BUTT STRAP LH (SHOWN)  
109G5330R01-310  
INTERNAL BUTT STRAP RH (OPPOSITE)  
EA9309.3NA ADHESIVE  
USE SEALANT MC 780 B-2  
ALL AROUND PERIMETER

INSTALL:  
NAS9307M-4-03 RIVET (4 OFF)  
COUNTERMARK WITH  
EXISTING HOLES

INSTALL:  
NAS9308M-4-03 RIVET (3 OFF)  
COUNTERMARK WITH  
EXISTING HOLES

INSTALL:  
NAS9307M-4-03 RIVET  
COUNTERMARK WITH  
EXISTING HOLES

INSTALL:  
109G5330R01-317 STIFFENER LH (SHOWN)  
109G5330R01-318 STIFFENER RH (OPPOSITE)  
APPLY:  
EA9309.3NA ADHESIVE  
USE SEALANT MC 780 B-2  
ALL AROUND PERIMETER

INSTALL:  
MS20426AD4 RIVET (4 OFF)  
COUNTERMARK WITH  
EXISTING HOLES

AA

INSTALL:  
NAS9301B-4-02 RIVET (33 OFF)  
COUNTERMARK WITH  
EXISTING HOLES

STA  
1815.0  
REF

INSTALL:  
NAS9302B-4-02 RIVET (8 OFF)  
COUNTERMARK WITH  
EXISTING HOLES

WL  
375.0  
REF

INSTALL:  
NAS9301B-4-03 RIVET (4 OFF)  
COUNTERMARK WITH  
EXISTING HOLES

WL  
270.0  
REF

INSTALL:  
A879A05L150 RIVET (3 OFF)  
COUNTERMARK WITH  
EXISTING HOLES

WL  
545.0  
REF  
TRACE

INSTALL:  
109G5330R01-315 WEB LH (SHOWN)  
109G5330R01-316 WEB RH (OPPOSITE)  
APPLY:  
EA9309.3NA ADHESIVE  
USE SEALANT MC 780 B-2  
ALL AROUND PERIMETER

N. 4 HOLES COUNTERMARK  
FROM EXISTING

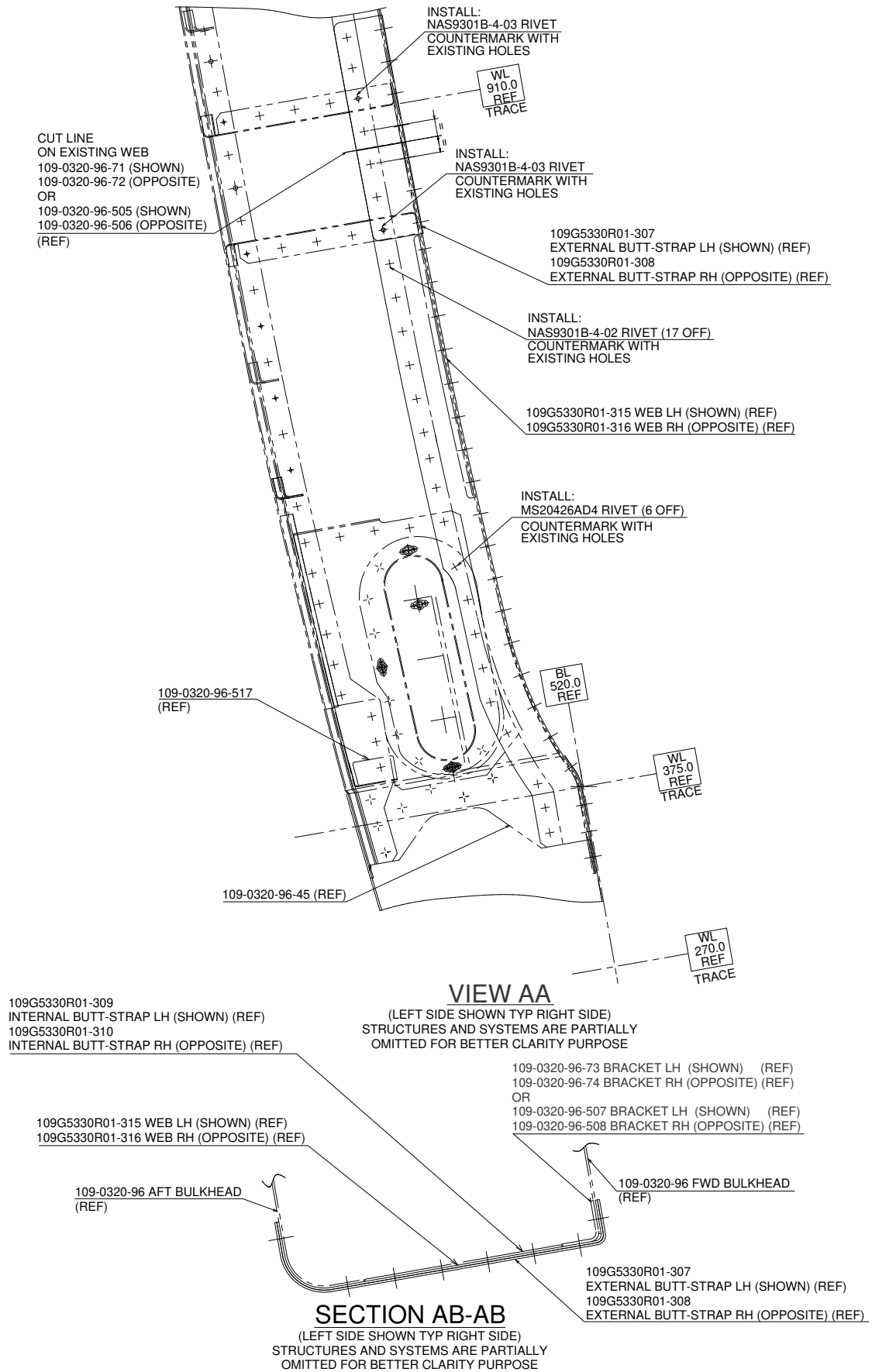
10°  
REF

WL  
70.0  
REF

### VIEW W

(LEFT SIDE SHOWN TYP RIGHT SIDE)  
STRUCTURES AND SYSTEMS ARE PARTIALLY  
OMITTED FOR BETTER CLARITY PURPOSE

Figure 23



**Figure 24**



109G5330R01-307  
INTERNAL BUTT-STRAP LH (SHOWN) (REF)  
109G5330R01-308  
INTERNAL BUTT-STRAP RH (OPPOSITE) (REF)

109G5330R01-311  
INTERNAL BUTT-STRAP LH (SHOWN) (REF)  
109G5330R01-312  
INTERNAL BUTT-STRAP RH (OPPOSITE) (REF)

WL  
910.0  
REF  
TRACE

CUT LINE  
ON EXISTING WEB  
109-0320-96-71 (SHOWN)  
109-0320-96-72 (OPPOSITE)  
OR  
109-0320-96-505 (SHOWN)  
109-0320-96-506 (OPPOSITE)  
(REF)

INTERNAL DOUBLER  
(REF)

CUT LINE ON  
EDGE DOUBLER

45.0

INSTALL:  
NAS9307M-4-03 RIVET (9 OFF)  
COUNTERMARK WITH  
EXISTING HOLES

AD →

CUT LINE  
ON EXISTING ANGLE  
109-0320-96-73 (SHOWN)  
109-0320-96-74 (OPPOSITE)  
OR  
109-0320-96-507 (SHOWN)  
109-0320-96-508 (OPPOSITE)  
(REF)

WL  
545.0  
REF  
TRACE

INSTALL:  
109G5330R01-305 ANGLE LH (SHOWN)  
109G5330R01-306 ANGLE RH (OPPOSITE)  
APPLY:  
EA9309.3NA ADHESIVE  
USE SEALANT MC 780 B-2  
ALL AROUND PERIMETER

109-0320-96-517 (REF)

109G5330R01-313 INTERNAL SHIM LH (SHOWN) (REF)  
109G5330R01-314 INTERNAL SHIM RH (OPPOSITE) (REF)

BL  
520.0  
REF

WL  
375.0  
REF

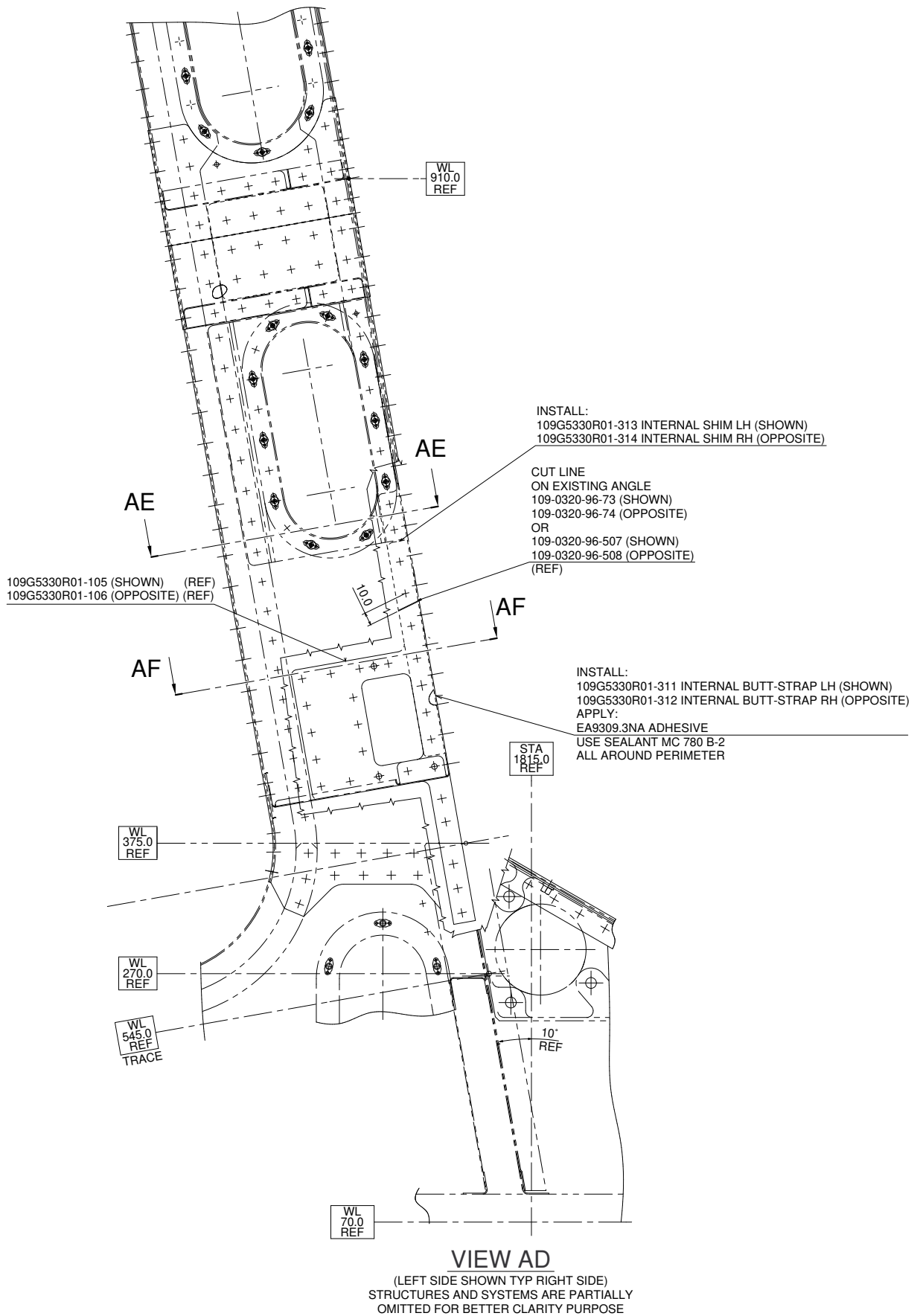
INSTALL:  
MS20470AD5 RIVET (3 OFF)  
COUNTERMARK WITH  
EXISTING HOLES

WL  
545.0  
REF  
TRACE

**DETAIL AC**

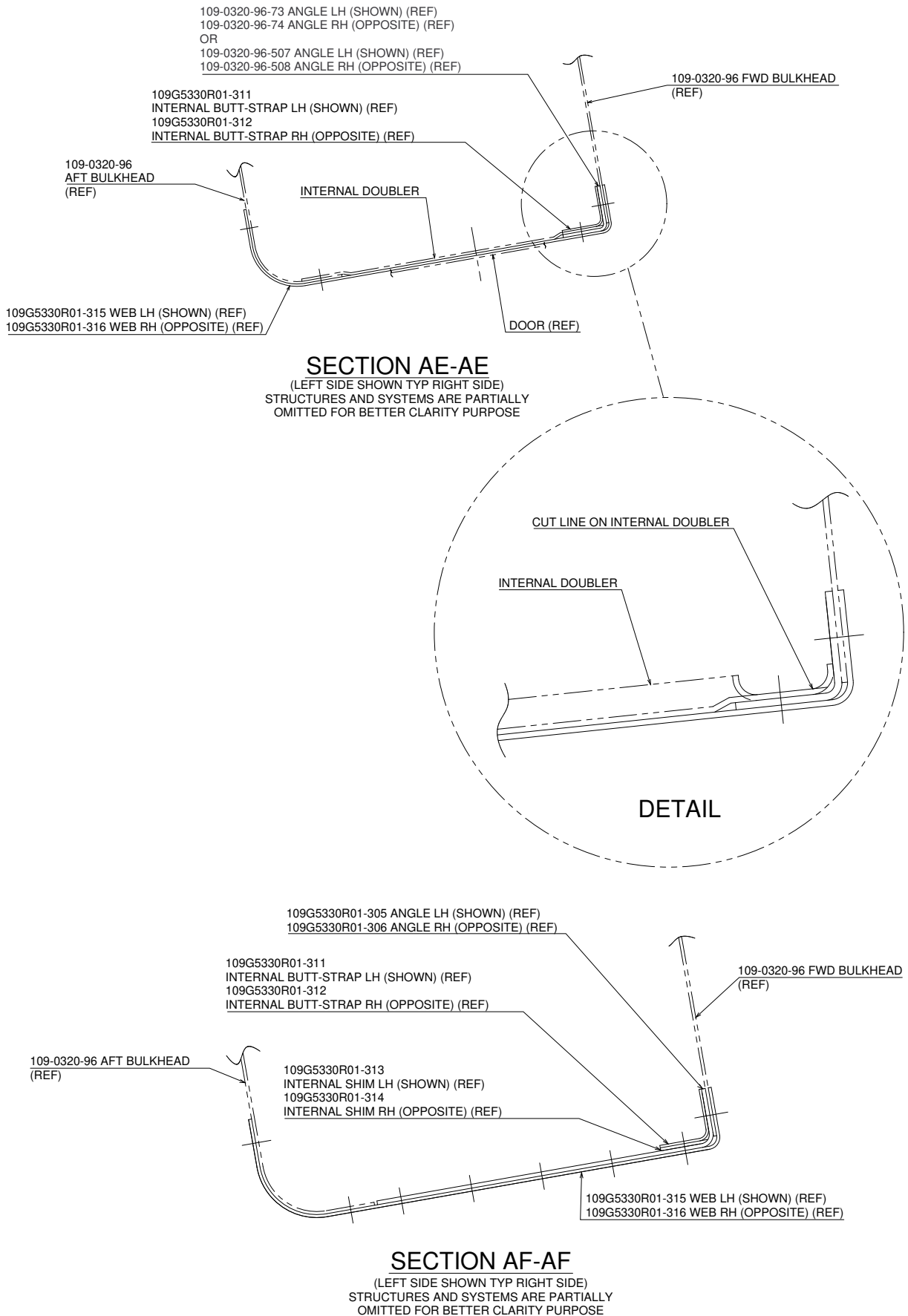
(LEFT SIDE SHOWN TYP RIGHT SIDE)  
STRUCTURES AND SYSTEMS ARE PARTIALLY  
OMITTED FOR BETTER CLARITY PURPOSE

**Figure 25**

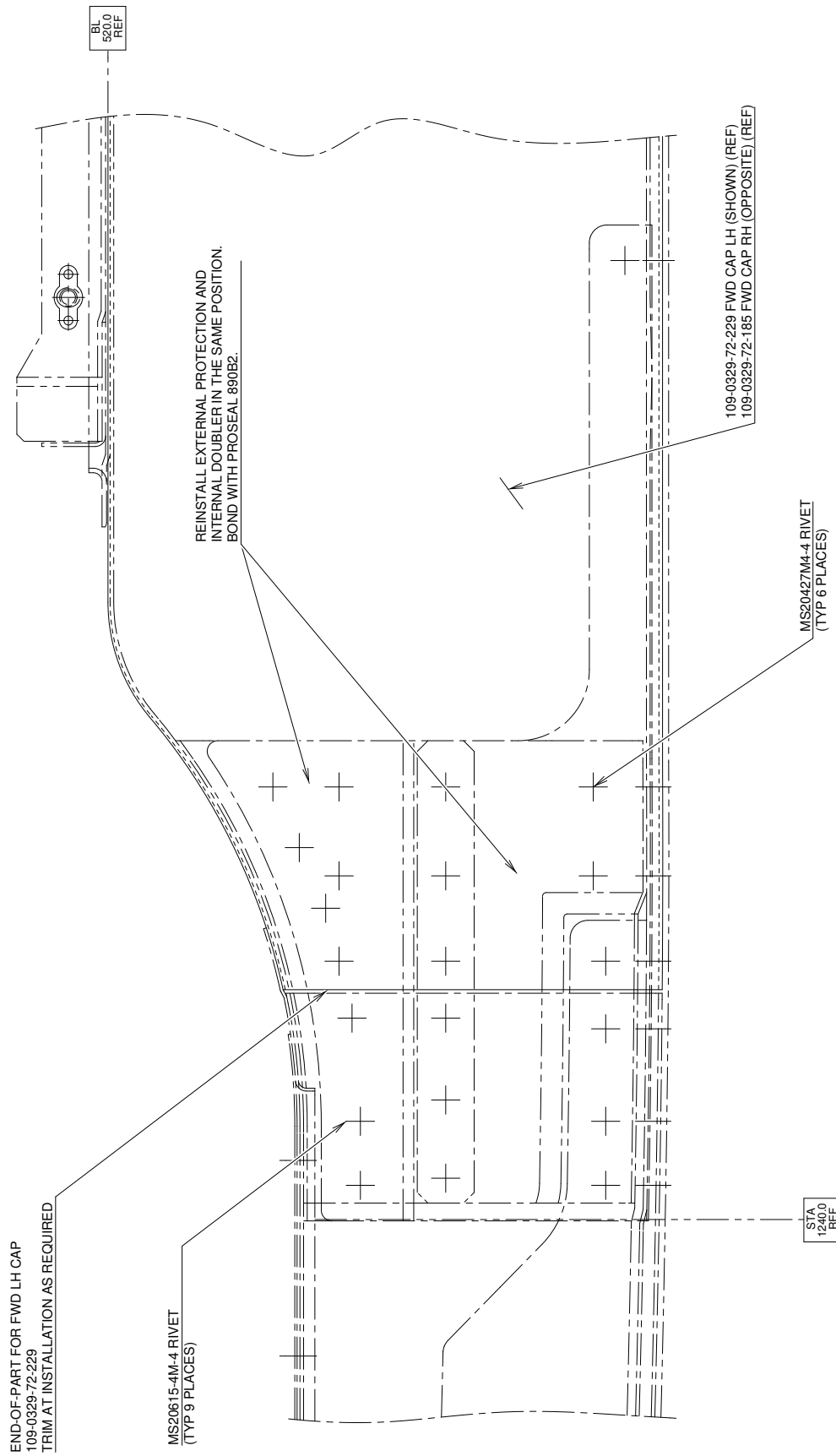


**Figure 26**

S.B. N°109EP-179 ALERT  
DATE: July 21, 2022  
REVISION: A - August 24, 2023



**Figure 27**



**VIEW AG**

(LH SIDE SHOWN TYP RIGHT SIDE)  
STRUCTURES AND SYSTEMS ARE PARTIALLY  
OMITTED FOR BETTER CLARITY PURPOSE

**Figure 28**

S.B. N°109EP-179 ALERT  
DATE: July 21, 2022  
REVISION: A - August 24, 2023

Please send to the following address:		<b>SERVICE BULLETIN COMPLIANCE FORM</b>		Date:	
<b>LEONARDO S.p.A.</b>		Number:			
CUSTOMER SUPPORT & SERVICES - ITALY					
PRODUCT SUPPORT ENGINEERING & LICENSES DEPT. Via Giovanni Agusta, 520 21017 Cascina Costa di Samarate (VA) - ITALY Tel.: +39 0331 225036 Fax: +39 0331 225988					
Customer Name and Address:		Revision:			
		Telephone:			
		Fax:			
		B.T. Compliance Date:			
Helicopter Model	S/N	Total Number	Total Hours	T.S.O.	
Remarks:					
Information:					
We request your cooperation in filling this form, in order to keep out statistical data relevant to aircraft configuration up-to-date. The form should be filled in all its parts and sent to the above address or you can communicate the application also via Technical Bulletin Application Communication Section placed in Leonardo AW Customer Portal - MyCommunications Area. We thank you beforehand for the information given.					