

---

---

SERVICE BULLETIN

N° **109EP-177**

**ALERT**

DATE: January 11, 2022

REV. : /

---

---

**TITLE**

**ATA 62 – INSPECTION OF MAIN ROTOR SCISSOR CHAIN**

**REVISION LOG**

First Issue

---

An appropriate entry should be made in the aircraft log book upon accomplishment.  
If ownership of aircraft has changed, please, forward to new owner.

---

## **1. PLANNING INFORMATION**

### **A. EFFECTIVITY**

**Part I:** all A109E helicopters.

**Part II:** all A109E helicopters not fulfilling Part I or Part IV or Part V requirements.

**Part III:** all A109E helicopters not fulfilling Part I or Part IV or Part V requirements.

**Part IV:** all A109E helicopters.

**Part V:** all A109E helicopters.

### **B. COMPLIANCE**

**Part I:** Within and not later than 25 FH or 3 months, whichever occurs first, after the issue of this Service Bulletin.

**Part II:** Every 25 FH until replacement of affected components as per Part III.

**Part III:** Within and not later than 400 FH or 2 years, whichever occurs first, after the detection of affected parts.

**Part IV:** Every 50FH.

**Part V:** Every 200FH.

### **C. CONCURRENT REQUIREMENTS**

N.A.

### **D. REASON**

This Service Bulletin is issued in order to provide the necessary instructions on how to perform the inspection of the main rotor scissor bearing P/N NHBY6V204.

### **E. DESCRIPTION**

Some cases of excessive axial play have been detected on the ball bearing of the lower half of the M/R rotating scissor assy. In few cases, this resulted in the slippage of the ball bearing outside its seat without jeopardizing the functionality of the scissor assy. These events have been detected on-ground during the required maintenance scheduled inspections or Pilot's Daily Pre-Flight Checks of the rotating scissor for condition and security. The investigation on the root cause is still ongoing but Leonardo Helicopters decided, as a precautionary measure, to issue this SB to perform (Part I) a one-time check to evaluate the correct coupling between the two halves of the rotating scissor assy and to check the axial play of the ball bearing P/N NHBY6V204. In case non-conformities are detected, instructions are provided to keep the axial play under control (Part II) until the replacement of the affected parts

(Part III). In addition, instructions are provided to perform qualitative (Part IV) and quantitative (Part V) evaluations of the axial play of the ball bearing as a regular inspection task.

## **F. APPROVAL**

The technical content of this Service Bulletin is approved under the authority of DOA nr. EASA.21.J.005. For helicopters registered under other Aviation Authorities, before applying the Service Bulletin, applicable Aviation Authority approval must be checked within Leonardo Helicopters customer portal.

EASA states mandatory compliance with inspections, modifications or technical directives and related time of compliance by means of relevant Airworthiness Directives.

If an aircraft listed in the effectivity embodies a modification or repair not LHD certified and affecting the content of this Service Bulletin, it is responsibility of the Owner/Operator to obtain a formal approval by Aviation Authority having jurisdiction on the aircraft, for any adaptation necessary before incorporation of the present Service Bulletin.

## **G. MANPOWER**

To comply with this Service Bulletin, the following MMH are deemed necessary:

Part I: 2 (two) MMH

Part II: 1 (one) MMH

Part III: 4 (four) MMH

Part IV: 0,30 (half an hour) MMH

Part V: 1 (one) MMH

MMH do not consider inspections and/or replacements which depend on inspections outcomes. MMH are based on hands-on time and can change with personnel and facilities available.

## **H. WEIGHT AND BALANCE**

N.A.

## **I. REFERENCES**

### **1) PUBLICATIONS**

Following Data Modules refer to MM:

<u>DATA MODULE</u>	<u>DESCRIPTION</u>	<u>PART</u>
DM01 00-20-1	Helicopter safety – Pre-operation	All
DM02 06-40-1	Access panels and doors	All
DM03 62-31-15	Rotating scissors, Maintenance Practices	All
DM04 62-31-16	Rotating scissors, Inspection	I, II, IV, V
DM05 62-31-25A	Swashplate and Support, Disassembly/Assembly	III
DM06 62-21-50	Floating ring, Removal/Installation	III

Following Data Modules refer to CR&OP:

<u>DATA MODULE</u>	<u>DESCRIPTION</u>	<u>PART</u>
DM07 3C-A-62-31-03-01C-921A-C	Lower lever - Bushings - Replacement (remove and install a new item)	III
DM08 3C-A-62-31-03-01B-921A-C	Lower lever - Bushings - Replacement (remove and install a new item)	III
DM09 3C-A-62-31-02-01C-921A-C	Upper lever - Bushings - Replacement (remove and install a new item)	III
DM10 3C-A-62-31-02-01B-921A-C	Upper lever - Bushings - Replacement (remove and install a new item)	III
DM11 3C-A-62-21-08-01A-921A-C	Scissors support flange - Bushings - Replacement (remove and install a new item)	III

## 2) ACRONYMS & ABBREVIATIONS

AMDI	Aircraft Material Data Information
MM	Maintenance Manual
CR&OP	Component Repair and Overhaul Publication
DM	Data Module
DOA	Design Organization Approval
EASA	European Aviation Safety Agency
LH	Leonardo Helicopters
MMH	Maintenance Man Hours
P/N	Part Number

## 3) ANNEX

ANNEX A – M/R rotating scissor force check

ANNEX B – M/R rotating scissor dimensional check

ANNEX C – M/R rotating scissor axial play check on board the helicopter

ANNEX D – M/R rotating scissor axial play check on ground

ANNEX E – Detailed compliance form

## **J. PUBLICATIONS AFFECTED**

A109E-MM Maintenance Manual A109E Helicopter Model.

## **K. SOFTWARE ACCOMPLISHMENT SUMMARY**

N.A.

## 2. MATERIAL INFORMATION

### A. REQUIRED MATERIALS

#### 1) PARTS

##### PART I

#	P/N	ALTERNATIVE P/N	DESCRIPTION	Q.TY	LVL	NOTE	LOG P/N
1	MS24665-283	MS24665-285	Pin, cotter	1	.	(1)	-
2	MS24665-302		Pin, cotter	1	.	(1)	-

##### PART II

N.A.

##### PART III

N.A.

##### PART IV

N.A.

##### PART V

N.A.

Refer also to IPC for the spare parts required to comply with the MM Paragraphs/CR&OP DM referenced in the accomplishment instructions.

#### 2) CONSUMABLES

Refer to AMDI for the consumable materials required to comply with the MM/CR&OP DM referenced in the accomplishment instructions.

#### 3) LOGISTIC MATRIX

N.A.

#### NOTE

(1) Item to be procured as local supply.

### B. SPECIAL TOOLS

The following special tools, or equivalent, are necessary to accomplish this Service Bulletin:

#	P/N	DESCRIPTION	Q.TY	NOTE	PART
3	Commercial	Dynamometer	1	(B1)	I

#	P/N	DESCRIPTION	Q.TY	NOTE	PART
4	Commercial	Non-elastic cable	1	(B1)	I
5	Commercial	Caliper	1	(B1)	I
6	Commercial or P/N 3G6005G04751	Support arm, dial gauge	1	(B2)	I,II,IV,V
7	Commercial or P/N 1502251	Dial gauge	1	(B2)	I,II,IV,V
8	Commercial or P/N 1500019	Extension dial gauge	1	(B2)	I,II,IV,V
9	Commercial or P/N 3G6005G01531	Support dial gauge (M/R damper hub side)	1	(B2)	I,II,IV,V

Refer also to PTUM for the special tools required to comply with the MM Paragraphs/CR&OP DM referenced in the accomplishment instructions.

Refer also to Annex A for the equipment/tools required for the force check of the main rotor rotating scissor.

Refer also to Annex B for the equipment/tools required for the dimensional check of the main rotor rotating scissor.

Refer also to Annex C for the equipment/tools required for the axial play measurement on board the helicopter.

#### **SPECIAL TOOLS NOTE**

(B1) Tool to be procured as local supply.

(B2) Equivalent P/N may be locally supplied or manufactured i.a.w. Annex C – Axial play measurement on board the helicopter.

### **C. INDUSTRY SUPPORT INFORMATION**

Owners/Operators who comply with the instructions of this Service Bulletin no later than the applicable date in the “Compliance” section will be eligible to receive REQUIRED MATERIALS on free of charge basis, except for Consumable Materials and Special Tools.

NOTE 1: Customers who fail to comply with the instructions in this Service Bulletin before the compliance date are not eligible for the aforementioned special policy.

Please Issue relevant MMIR form to your Warranty Administration Dpt accompanied by INSPECTION REPORT and PICTURE of the affected area.

NOTE 2: The INSPECTION REPORT and PICTURE are mandatory; in case the MMIR is not accompanied by these documents, it will be rejected.

### **3. ACCOMPLISHMENT INSTRUCTIONS**

#### **GENERAL NOTES**

- a) Place an identification tag on all components that are re-usable, including the attaching hardware that has been removed to gain access to the modification area and adequately protect them until their later re-use.
- b) Exposed thread surface and nut must be protected using a layer of tectyl according to MIL-C-16173 grade I.
- c) All lengths are in mm.
- d) The items indicated in this Service Bulletin can be installed on the helicopter with different P/N. Refer to IPD Chapter 62 for the applicable P/N.
- e) The logics of operations and instructions required into this SB are explained at high level in the flow chart reported in Figure 1.

#### **PART I**

1. In accordance with MM Paragraph 00-20-1, prepare the helicopter on ground for a safe maintenance. Disconnect the battery, all electrical power sources and/or the external power supply.
2. **M/R rotating scissor coupling inspection**
  - 2.1 Perform the upper and lower M/R rotating scissor lever reference value force check as per Annex A step 3.
  - 2.2 Perform the upper and lower M/R rotating scissor lever maximum torque force check as per Annex A step 4.

#### **NOTE**

Reinstall new cotter-pins and nuts according to the applicable AMP DMs.



### NOTE

The completion of the installation of the M/R rotating scissor assy is not required if the axial play check at step 3 will be performed directly on ground and not on board the helicopter.

- 2.3 If at least one of the measures at steps 4.1.4 and 4.1.6 of Annex A is not within acceptable values, perform Dimensional Check as per Annex B and proceed with step 2.4, otherwise complete the installation of the M/R scissor assy i.a.w. MM Paragraph 62-31-15 and proceed with Step 3.
- 2.4 If at least one of the dimensional checks required by Annex B has failed, in accordance with MM Paragraph 62-31-15, reinstall the M/R rotating scissor. Proceed with Step 3.
- 2.5 If all checks as per Annex B are compliant with allowable limits, in accordance with MM Paragraph 62-31-15, partially install the M/R scissor assy attaching only the upper scissor lever assy to the bracket flange assy.
- 2.6 Repeat M/R rotating scissor maximum torque force check as per Annex A step 4. If this second application is failed, contact Leonardo Helicopters for instructions.
- 2.7 In accordance with MM Paragraph 62-31-15, reinstall the lower scissor lever assy on the swashplate retaining bolt. Proceed to Step 3.

### **3. M/R rotating scissor axial play check**

#### NOTE

If the ball bearing is found dislodged from its seat, record the finding on the Annex E – Detailed compliance form and proceed directly with step 4.

#### NOTE

If support arm P/N 3G6005G04751 or equivalent is not available or the M/R rotating scissor assy has been already removed from the helicopter it is possible to perform the axial play check on ground i.a.w. Annex D.

- 3.1 In accordance with Annex C or with Annex D, as applicable, perform the axial play check of the ball bearing P/N NHBY6V204.
- 3.2 Record the value measured in Annex E – Detailed compliance form and proceed with step 4.

### **4. Inspection Outcomes**

- 4.1 With reference to Figure 1 and to the results of the inspections recorded into the detailed compliance form (Annex E), define the applicable actions as required by

Table 1 and proceed with step 0:

**NOTE**

Colours used in Table 1 recalls the outcomes of Scissor Coupling Check and Axial Play inspection as detailed in the flow chart reported in Figure 1 and in the Detailed Compliance Form:

- Green: Test passed
- Yellow: Test failed.
- Red: Axial Play Check failed (axial play greater than 0.75mm). Immediate replacement of parts identified in Table 1 is required.
- Grey: Contact Leonardo Helicopters.

		Step 2 - SCISSOR COUPLING CHECK		
		PASSED	FAILED	UNCERTAIN RESULT (2 <sup>ND</sup> maximum torque force check failed)
S t e p 3  A X I A L  P L A Y  C H E C K	PASSED	Consider the helicopter affected by Part IV and Part V.	Consider the helicopter affected by Part II until replacement of all affected components as per Part III and then consider the helicopter affected by Part IV and Part V.	Contact Leonardo Helicopters.
	FAILED (axial play value between 0.25 mm and 0.75 mm)	Consider the helicopter affected by Part II until replacement of all affected components as per Part III and then consider the helicopter affected by Part IV and Part V.	Consider the helicopter affected by Part II until replacement of all affected components as per Part III and then consider the helicopter affected by Part IV and Part V.	
	FAILED (axial play value greater than 0.75 mm)	Before next flight, replace lower scissor lever assy as per Part III and then consider the helicopter affected by Part IV and Part V.	Before next flight, replace lower scissor lever assy as per Part III. If the lower scissor lever is the only component not fulfilling Part I dimensional check, consider the helicopter affected by Part IV, otherwise consider the helicopter affected by Part II until replacement of all affected components as per Part III and then consider the helicopter affected by Part IV and Part V.	
	FAILED (ball bearing dislodged)	Before next flight, replace lower scissor lever assy, retaining bolt and washer as per Part III and then consider the helicopter affected by Part IV and Part V.	Before next flight, replace lower scissor lever assy, retaining bolt and washer as per Part III. If the lower scissor lever is the only component not fulfilling part I dimensional check, consider the helicopter affected by Part IV, otherwise consider the helicopter affected by Part II until replacement of all affected components as per Part III and then consider the helicopter affected by Part IV and Part V.	

**Table 1 - Part I inspections - Outcomes assessment**

5. With reference to MM Paragraph 06-40-1, reinstall the access panels P15 and P21 on the helicopter.
6. Return the helicopter to flight configuration and record for compliance with Part I of this Service Bulletin on the helicopter logbook.

**NOTE**

“XXXXX” in the subject line below is the helicopter S/N.

7. Send the detailed compliance form (Annex E) with Subject line “109EP-177 Rev./ - S/N XXXXX - Detailed Compliance Form” to the following mail box:

[engineering.support.lhd@leonardocompany.com](mailto:engineering.support.lhd@leonardocompany.com)

8. Send the attached compliance form to the following mail box:

[engineering.support.lhd@leonardocompany.com](mailto:engineering.support.lhd@leonardocompany.com)

As an alternative, gain access to My Communications section on Leonardo WebPortal and compile the “Service Bulletin Application Communication”.

## **PART II**

1. In accordance with MM Paragraph 00-20-1, prepare the helicopter on ground for a safe maintenance. Disconnect the battery, all electrical power sources and/or the external power supply.
2. With reference to MM Paragraph 06-40-1, remove the access panels P17, P18 and P24 from the helicopter.

### **NOTE**

If the ball bearing is found dislodged from its seat, record the finding and proceed directly with step 4.

### **NOTE**

If support arm P/N 3G6005G04751 or equivalent is not available or the M/R rotating scissor has been already removed from the helicopter it is possible to perform axial play check on ground i.a.w. Annex D.

3. In accordance with Annex C or Annex D, as applicable, perform the axial play check of the ball bearing P/N NHBY6V204 directly on board the helicopter. Record the measure acquired.
4. Accounting for the results of the inspection performed at step 3, perform the actions below:
  - 4.1 If axial play value is between 0.25 mm and 0.75 mm, proceed with step 5.

### **NOTE**

If the lower scissor lever is the only component not fulfilling Part I requirements, after accomplishment of step 4.2 or 4.3, the helicopter has to be considered affected by Part IV and Part V.

- 4.2 If axial play value is greater than 0.75 mm, replace lower scissor lever assy P/N 109-0134-25-101 (or P/N 109-0134-10-105 or P/N 109-0134-10-101) as per Part III and proceed with step 5.
- 4.3 If ball bearing is found dislodged, replace lower scissor lever assy P/N 109-0134-25-101 (or P/N 109-0134-10-105 or P/N 109-0134-10-101), retaining bolt and washer as per Part III and proceed with step 5.
5. With reference to MM Paragraph 06-40-1, reinstall the access panels P17, P18 and P24 on the helicopter.
6. Return the helicopter to flight configuration and record for compliance with Part II of this Service Bulletin on the helicopter logbook.
7. Send the attached compliance form to the following mail box:

[engineering.support.lhd@leonardocompany.com](mailto:engineering.support.lhd@leonardocompany.com)

As an alternative, gain access to My Communications section on Leonardo WebPortal and compile the “Service Bulletin Application Communication”.

**PART III**

1. In accordance with MM Paragraph 00-20-1, prepare the helicopter on ground for a safe maintenance. Disconnect the battery, all electrical power sources and/or the external power supply.
2. With reference to MM Paragraph 06-40-1, remove the access panels P17, P18 and P24 from the helicopter.
3. With reference to MM Paragraph 62-31-15, remove the rotating scissor assy from the helicopter.

**NOTE**

- If spare components (any of the parts reported in Table 2) have to be replaced, they can be referred to as serviceable only after being positively checked as per Annex B (dimensional check) before installation on board the helicopter.
- A complete spare rotating scissor assy can be referred to as serviceable if positively tested according to Annex A step 4 (force check).

4. With reference to Table 2 and steps below, replace the components found outside the tolerances defined in Part I (as reported in the Detailed Compliance Form in Annex E) with a serviceable part as follows:

**NOTE**

If the nut P/N MS17825-6 is removed, discard the part and replace with a new one according to applicable DM.

Description	P/N	For replacement, refer to step
Scissor Bracket Flange assy	109-0111-49-101 or 109-0111-11-105	4.1
Rotary Scissor Sleeve	109-0110-69-109 or 109-0110-69-105	4.2
Rotary Scissor Sleeve	109-0110-69-111	4.3

	or 109-0110-69-107	
Lower Scissor Lever assy	109-0134-25-101 or 109-0134-10-101 or 109-0134-10-105	4.4
Upper Scissor Lever assy	109-0134-23-105 or 109-8110-16-1	4.5

**Table 2**

- 4.1 For scissor bracket flange assy P/N 109-0111-49-101 (or P/N 109-0111-11-105), perform the actions below:
- 4.1.1 With reference to MM Paragraph 62-21-50, remove the scissor bracket flange assy from the helicopter.
- CAUTION**
- Only approved personnel (Leonardo Helicopters Facilities, Leonardo Authorized Component Repair Centres within the approved capabilities or Customers trained by Leonardo Helicopters for specific activities) are permitted to perform the bushing replacement according to step 4.1.2.
- 4.1.2 If all the out of tolerances dimensions can be restored replacing the bushings, with reference to CR&OP DM 3C-A-62-21-08-01A-921A-C, perform replacement of bushings and, with reference to MM Paragraph 62-21-50, reinstall the restored scissor bracket flange assy and proceed with step 5. Otherwise proceed with next step.
- 4.1.3 With reference to MM Paragraph 62-21-50, discard and replace the scissor bracket flange assy.
- 4.2 For rotary scissor sleeve P/N 109-0110-69-109 (or P/N 109-0110-69-105), perform the actions below:
- 4.2.1 With reference to MM Paragraph 62-31-15, discard and replace the rotary scissor sleeve and install the rotating scissor assy.
- 4.3 For rotary scissor sleeve P/N 109-0110-69-111 (or 109-0110-69-107) replacement, perform the actions below:

- 4.3.1 With reference to MM Paragraph 62-31-15, disassemble the rotating scissor assy.
- 4.3.2 With reference to MM Paragraph 62-31-15, discard and replace the rotary scissor sleeve and assemble the rotating scissor assy.
- 4.4 For lower scissor lever assy P/N 109-0134-25-101 (or 109-0134-10-105 or 109-0134-10-101), perform the actions below:
  - 4.4.1 With reference to MM Paragraph 62-31-15, disassemble the rotating scissor assy.

**CAUTION**

Only approved personnel (Leonardo Helicopters Facilities, Leonardo Authorized Component Repair Centres within the approved capabilities or Customers trained by Leonardo Helicopters for specific activities) are permitted to perform the bushing replacement according to step 4.4.2.

- 4.4.2 If all the out of tolerances dimensions can be restored replacing the bushings (and the axial play measured at Part I is not greater than 0.25 mm) with reference to CR&OP DM 3C-A-62-31-03-01C-921A-C for P/N 109-0134-25-101 (CR&OP DM 3C-A-62-31-03-01B-921A-C for P/N 109-0134-10-105 or P/N 109-0134-10-101), perform replacement of bushings and, with reference to MM Paragraph 62-31-15, assemble the rotating scissor assy and proceed with step 5. Otherwise proceed with next step.
- 4.4.3 With reference to MM Paragraph 62-31-15, discard and replace the lower scissor lever assy and reassemble the rotating scissor assy.

**NOTE**

If the bearing ball has been found out of its seat, perform steps 4.4.4 and 4.4.5.

- 4.4.4 Discard and replace the washer P/N 109-0130-49-1.
- 4.4.5 With reference to MM Paragraph 62-31-25A, discard and replace the retaining bolt P/N NAS1306-28D.
- 4.5 For upper scissor lever assy P/N 109-0134-23-105 (or P/N 109-8110-16-1) replacement, perform the actions below:
  - 4.5.1 With reference to MM Paragraph 62-31-15, disassemble the rotating scissor assy.



### **CAUTION**

Only approved personnel (Leonardo Helicopters Facilities, Leonardo Authorized Component Repair Centres within the approved capabilities or Customers trained by Leonardo Helicopters for specific activities) are permitted to perform the bushing replacement according to step 4.5.2

4.5.2 If all the out of tolerances dimensions can be restored replacing the bushings, with reference to CR&OP DM 3C-A-62-31-02-01C-921A-C for P/N 109-0134-23-105 (CR&OP DM 3C-A-62-31-02-01B-921A-C for P/N 109-8110-16-1), perform replacement of bushings and, with reference to MM Paragraph 62-31-15, assemble the rotating scissor assy and proceed with step 5. Otherwise proceed with next step.

4.5.3 With reference to MM Paragraph 62-31-15, discard and replace the upper scissor lever assy and reassemble the rotating scissor assy.

5. Perform the maximum torque force check as per Annex A step 4. If at least one of the measures at steps 4.1.4 and 4.1.6 of Annex A is not within acceptable values, contact Leonardo Helicopters for instructions, otherwise proceed with next step.
6. With reference to MM Paragraph 06-40-1, reinstall the access panels P17, P18 and P24 on the helicopter.
7. Return the helicopter to flight configuration and record for compliance with Part III of this Service Bulletin on the helicopter logbook.
8. Send the attached compliance form to the following mail box:

[engineering.support.lhd@leonardocompany.com](mailto:engineering.support.lhd@leonardocompany.com)

As an alternative, gain access to My Communications section on Leonardo WebPortal and compile the "Service Bulletin Application Communication".

## **PART IV**

### **NOTE:**

If complying with a 200FH inspection, Part IV is not required. Perform only Part V.

1. In accordance with MM Paragraph 00-20-1, prepare the helicopter on ground for a safe maintenance. Disconnect the battery, all electrical power sources and/or the external power supply.
2. With reference to MM Paragraph 06-40-1, remove the access panels P17, P18 and P24 from the helicopter.
3. In accordance to the steps below, perform the qualitative axial play check of the ball bearing P/N NHBY6V204 directly on board the helicopter:
  - 3.1 Pull and push repetitively the rotating scissor assy along the retaining bolt axis to detect possible unusual axial play check.
  - 3.2 If no unusual play is detected, proceed with step 5, otherwise go to step 3.3.
  - 3.3 If unusual play is detected, perform a quantitative axial play check as described at step 4.
4. In accordance to the steps below, perform the quantitative axial play check of the ball bearing P/N NHBY6V204:

### **NOTE**

If support arm P/N 3G6005G04751 or equivalent is not available or the M/R rotating scissor assy has been already removed from the helicopter it is possible to perform axial play check on ground i.a.w. Annex D.

- 4.1 In accordance with Annex C or Annex D, as applicable, perform the axial play check of the ball bearing P/N NHBY6V204.
- 4.2 If the axial play is not greater than 0.25 mm, proceed with step 5
- 4.3 If the axial play is between 0.25 mm and 0.75 mm, perform Part II until the replacement of affected components as per Part III.
- 4.4 If the axial play is greater than 0.75 mm, replace the lower scissor lever assy as per Part III and then consider the helicopter affected by Part IV and Part V.
5. With reference to MM Paragraph 06-40-1, reinstall the access panels P17, P18 and P24 on the helicopter.
6. Return the helicopter to flight configuration and record for compliance with Part IV of this Service Bulletin on the helicopter logbook.
7. Send the attached compliance form to the following mail box:

[engineering.support.lhd@leonardocompany.com](mailto:engineering.support.lhd@leonardocompany.com)

As an alternative, gain access to My Communications section on Leonardo WebPortal and compile the “Service Bulletin Application Communication”.

## **PART V**

### **NOTE:**

If complying with a 200FH inspection, Part IV is not required. Perform only Part V.

1. In accordance with MM Paragraph 00-20-1, prepare the helicopter on ground for a safe maintenance. Disconnect the battery, all electrical power sources and/or the external power supply.
2. With reference to MM Paragraph 06-40-1, remove the access panels P17, P18 and P24 from the helicopter.
3. In accordance to the steps below, perform the quantitative axial play check of the ball bearing P/N NHBY6V204:

### **NOTE**

If support arm P/N 3G6005G04751 or equivalent is not available or the M/R rotating scissor assy has been already removed from the helicopter it is possible to perform axial play check on ground i.a.w. Annex D.

- 3.1 In accordance with Annex C or Annex D, as applicable, perform the axial play check of the ball bearing P/N NHBY6V204.
- 3.2 If the axial play is not greater than 0.25 mm, proceed with step 4
- 3.3 If the axial play is between 0.25 mm and 0.75 mm, perform Part II until the replacement of affected components as per Part III.
- 3.4 If the axial play is greater than 0.75 mm, replace the lower scissor lever assy as per Part III and then consider the helicopter affected by Part IV and Part V.
4. With reference to MM Paragraph 06-40-1, reinstall the access panels P17, P18 and P24 on the helicopter.
5. Return the helicopter to flight configuration and record for compliance with Part V of this Service Bulletin on the helicopter logbook.
6. Send the attached compliance form to the following mail box:

[engineering.support.lhd@leonardocompany.com](mailto:engineering.support.lhd@leonardocompany.com)

As an alternative, gain access to My Communications section on Leonardo WebPortal and compile the "Service Bulletin Application Communication".

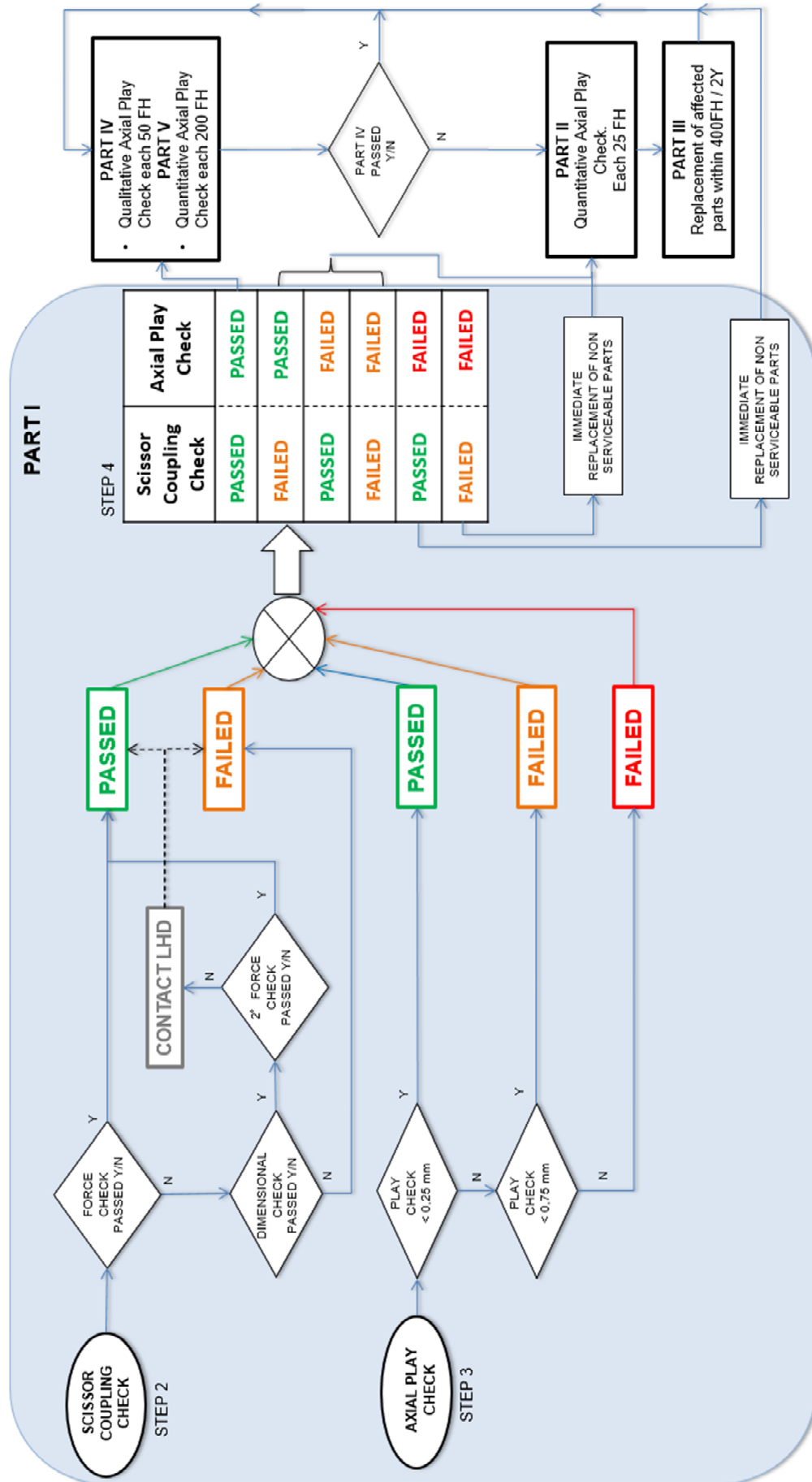


Figure 1

# ANNEX A

## M/R ROTATING SCISSOR FORCE CHECK

## 1 PURPOSE AND APPLICABILITY

This procedure details the instructions to perform the force check of the M/R rotating scissor assy.

## 2 EQUIPMENT AND MATERIALS

The following materials, equipment and tools are requested.

### 2.1 MATERIALS

N.A.

### 2.2 EQUIPMENT/TOOLS

- a. Dynamometer
- b. Non-elastic cable

## 3 REFERENCE FORCE CHECK INSTRUCTION

- 3.1 With reference to MM Paragraph 06-40-1, remove the access panels P17, P18 and P24 from the helicopter.
- 3.2 With reference to Figures A1 and A2, using a dynamometer, perform the reference force check of the rotating scissor assy as follows:
  - 3.2.1 With reference to MM paragraph 62-31-15, detach the lower scissor lever assy from the retaining bolt. Discard the nut P/N MS17825-6.

### NOTE

For better accessibility to the interested area, pull down the collective control lever.

### NOTE

To perform the measure described at step 3.2.2 and 3.2.4, use a non-elastic cable.

- 3.2.2 With reference to Figure A1, with upper scissor lever in horizontal position and lower scissor lever in vertical position, using a suitable cable installed on the fulcrum point of the rotating scissor assy, measure the force along the vertical direction needed to lift the rotating scissor assy.
- 3.2.3 Record the measure in Annex E - Detailed compliance form.
- 3.2.4 With reference to Figure A2, using a suitable cable installed on the lower part of the lower scissor lever, keeping fixed in position the upper scissor lever in horizontal position, measure the force needed for the relative rotation between the lower scissor lever and the upper scissor lever.
- 3.2.5 Record the measure in Annex E - Detailed compliance form.

## 4 MAXIMUM TORQUE FORCE CHECK INSTRUCTION

### NOTE

The check at step 4.1 must be performed with components properly cleaned by dust, sand, excess of lubricating grease and corrosion protecting compound from the affected fittings. No removal or disassembly is required.

4.1 With reference to Figure A1 and A2, using a dynamometer, perform the maximum torque force check as follows:

4.1.1 If not already performed, with reference to MM Paragraph 62-31-15, detach the lower scissor lever assy from the retaining bolt. Discard the nut P/N MS17825-6.

### NOTE

For better accessibility to the interested area, pull down the collective control lever.

### NOTE

Remove from the bevels of the upper scissor lever any primer and print burrs in the area of coupling between the upper scissor and lower scissor levers.

4.1.2 Remove and discard the cotter pin P/N MS24665-283 or MS24665-285 that attaches the upper scissor lever to the lower scissor lever and torque the nut P/N MS17825-6 to the torque of 10.0 N·m.

### NOTE

Remove from the bevels of the flange any primer and print burrs in the area of coupling between the upper scissor lever and scissor bracket flange.

4.1.3 Remove and discard the cotter pin P/N MS24665-302 that attaches the upper scissor lever to the scissor bracket flange and torque the nut P/N MS17825-6 to the torque of 10.0 N·m.

### NOTE

To perform the measure described at step 4.1.4 and 4.1.6, use a non-elastic cable.

4.1.4 With reference to Figure A1, with upper scissor lever in horizontal position and lower scissor lever in vertical position, using a suitable cable installed



on the fulcrum point of the rotating scissor assy, measure the force along the vertical direction needed to lift the rotating scissor assy.

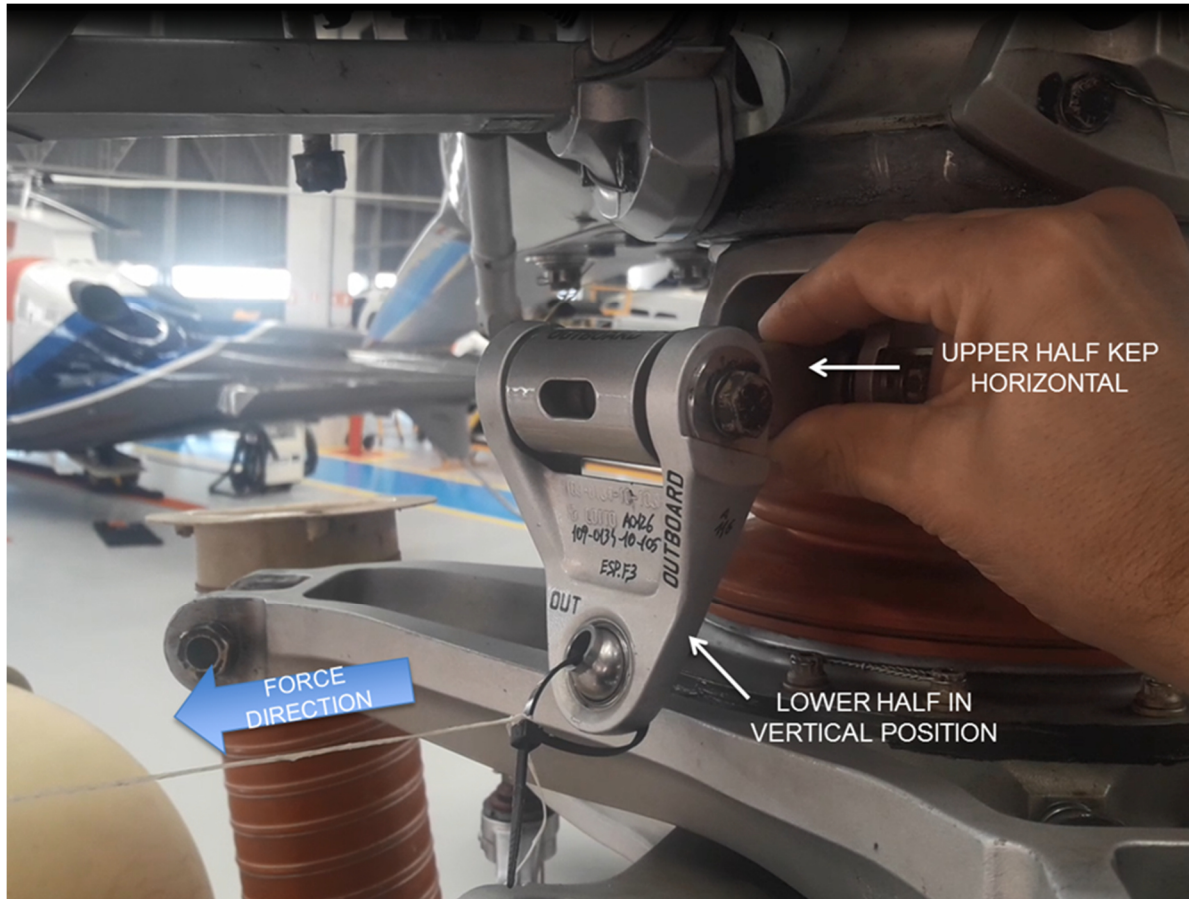
- 4.1.5 Record the measure in Annex E - Detailed compliance form. The maximum acceptable value is 6.7 N.
- 4.1.6 With reference to Figure A2, using a suitable cable installed on the lower part of the lower scissor lever, keeping fixed in position the upper scissor lever in horizontal position, measure the force needed for the relative rotation between the lower scissor lever and the upper scissor lever.
- 4.1.7 Record the measure in Annex E - Detailed compliance form. The maximum acceptable value is 3.1 N.



For reference only: the scissor in the picture could not be fully representative of the item actually installed on the aircraft

**Figure A1**

S.B. N°109EP-177 ALERT  
DATE: January 11, 2022  
REVISION: /



For reference only: the scissor in the picture could not be fully representative of the item actually installed on the aircraft

**Figure A2**

# ANNEX B

## M/R ROTATING SCISSOR DIMENSIONAL CHECK

## 1 PURPOSE AND APPLICABILITY

This procedure details the instructions to perform the dimensional check of the M/R rotating scissor.

## 2 EQUIPMENT AND MATERIALS

The following materials, equipment and tools are requested.

### 2.1 MATERIALS

N.A.

### 2.2 EQUIPMENT/TOOLS

a. Calliper

## 3 DIMENSIONAL CHECK INSTRUCTION

- 3.1 With reference to MM Paragraph 62-31-15, remove the M/R rotating scissor assy from the helicopter. Discard the nut P/N MS17825-6 that attaches the upper scissor lever to the scissor bracket flange.
- 3.2 With reference to MM Paragraph 62-31-15, disassemble the M/R rotating scissor assy. Discard the nut P/N MS17825-6.
- 3.3 With reference to Figures B1 thru B4, using a calliper, perform the dimensional check of the components described as follows:

### NOTE

If the helicopter installs the rotating scissor assy P/N 109-0134-21-103 perform steps 3.3.1 thru 3.3.8 and then proceed with step 3.3.16.

If the helicopter installs the rotating scissor assy P/N 109-0134-09-101 perform steps 3.3.9 thru 3.3.15.

- 3.3.1 With reference to Figure B1 Section B-B, measure the dimension "a" in four different positions, spaced 90 degrees apart. Allowable values are  $a = 63.15 \div 63.20$  mm. Record the measured values in Annex E - Detailed compliance form.
- 3.3.2 With reference to Figure B2 Section B-B, measure the dimension "b" in four different positions, spaced 90 degrees apart. Allowable values are  $b = 59.15 \div 59.20$  mm. Record the measured values in Annex E - Detailed compliance form.

- 3.3.3 With reference to Figure B2 Section B-B, measure the dimension “c” in four different positions, spaced 90 degrees apart. Allowable values are  $c = 63.20 \div 63.25$  mm. Record the measured values in Annex E - Detailed compliance form.
- 3.3.4 With reference to Figure B2 Section B-B, measure the dimension “d” in four different positions, spaced 90 degrees apart. Allowable values are  $d = 86.95 \div 87.285$  mm. Record the measured values in Annex E - Detailed compliance form.
- 3.3.5 With reference to Figure B3 Section A-A, measure the dimension “e” in four different positions, spaced 90 degrees apart. Allowable values are  $e = 74.10 \div 74.15$  mm. Record the measured values in Annex E - Detailed compliance form.
- 3.3.6 With reference to Figure B3 Section A-A, measure the dimension “f” in four different positions, spaced 90 degrees apart. Allowable values are  $f = 87.20 \div 87.25$  mm. Record the measured values in Annex E - Detailed compliance form.
- 3.3.7 With reference to Figure B4 Detail A, measure the dimension “g” in four different positions, spaced 90 degrees apart. Allowable values are  $g = 59.20 \div 59.25$  mm. Record the measured values in Annex E - Detailed compliance form.
- 3.3.8 With reference to Figure B4 Detail A, measure the dimension “h” in four different positions, spaced 90 degrees apart. Allowable values are  $h = 74.00 \div 74.185$  mm. Record the measured values in Annex E - Detailed compliance form.
- 3.3.9 With reference to Figure B5, measure the dimension “i” in four different positions, spaced 90 degrees apart. Allowable values are  $i = 74.95 \div 75.285$  mm. Record the measured values in Annex E - Detailed compliance form.
- 3.3.10 With reference to Figure B5, measure the dimension “j” in four different positions, spaced 90 degrees apart. Allowable values are  $j = 51.20 \div 51.25$  mm. Record the measured values in Annex E - Detailed compliance form.
- 3.3.11 With reference to Figure B6, measure the dimension “k” in four different positions, spaced 90 degrees apart. Allowable values are  $k = 51.15$  mm  $\div$  51.20 mm. Record the measured values in Annex E - Detailed compliance form.
- 3.3.12 With reference to Figure B7 Section A-A, measure the dimension “l” in four different positions, spaced 90 degrees apart. Allowable values are

$l = 66.10 \text{ mm} \div 66.15 \text{ mm}$ . Record the measured values in Annex E - Detailed compliance form.

3.3.13 With reference to Figure B7 Section B-B, measure the dimension “m” in four different positions, spaced 90 degrees apart. Allowable values are  $m = 75.20 \div 75.25 \text{ mm}$ . Record the measured values in Annex E - Detailed compliance form.

3.3.14 With reference to Figure B8 Detail A, measure the dimension “n” in four different positions, spaced 90 degrees apart. Allowable values are  $n = 51.20 \div 51.25 \text{ mm}$ . Record the measured values in Annex E - Detailed compliance form.

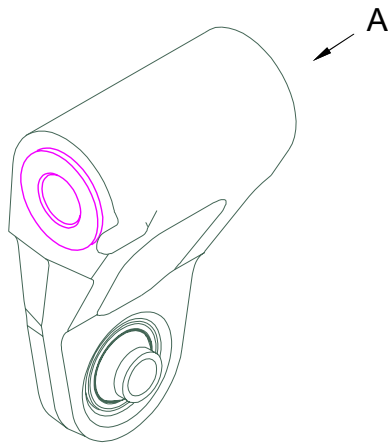
3.3.15 With reference to Figure B8 Detail A, measure the dimension “o” in four different positions, spaced 90 degrees apart. Allowable values are  $o = 66.00 \div 66.10 \text{ mm}$ . Record the measured values in Annex E - Detailed compliance form.

**NOTE**

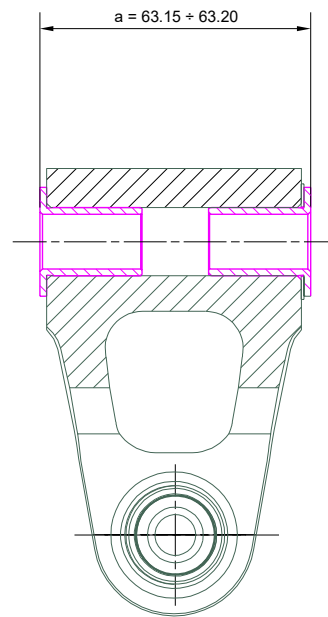
Reinstall new cotter-pins and nuts according to the applicable AMP DMs.

3.3.16 With reference to MM Paragraph 62-31-15 reassemble M/R rotating scissor assy.

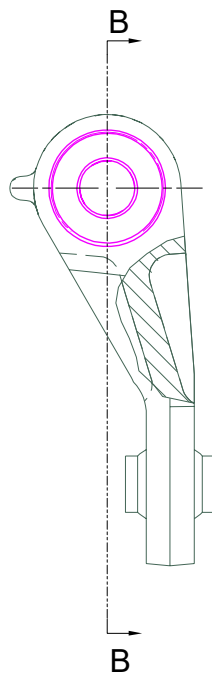
### Lower Scissor Lever Assy



ISO VIEW



SECTION B-B



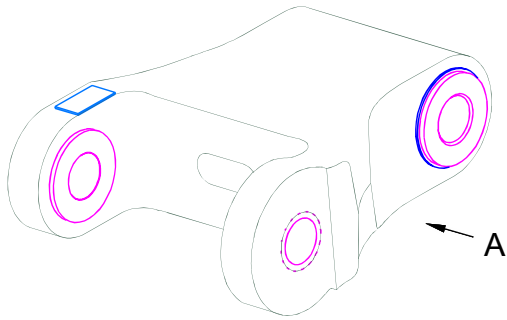
VIEW A

**Figure B1**

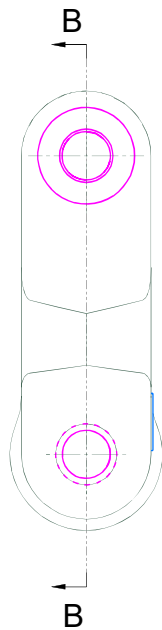
S.B. N°109EP-177 ALERT  
DATE: January 11, 2022  
REVISION: /



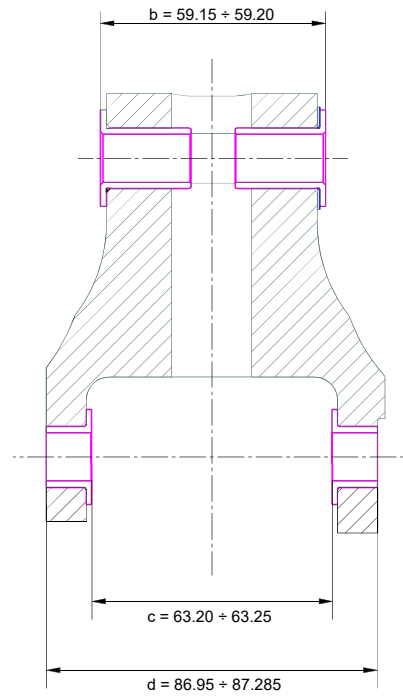
### Upper Scissor Lever Assy



ISO VIEW



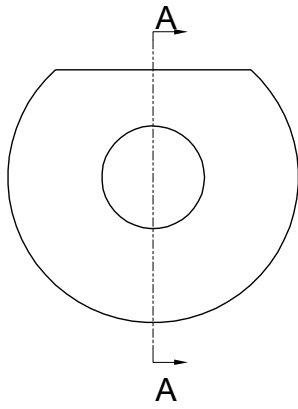
VIEW A



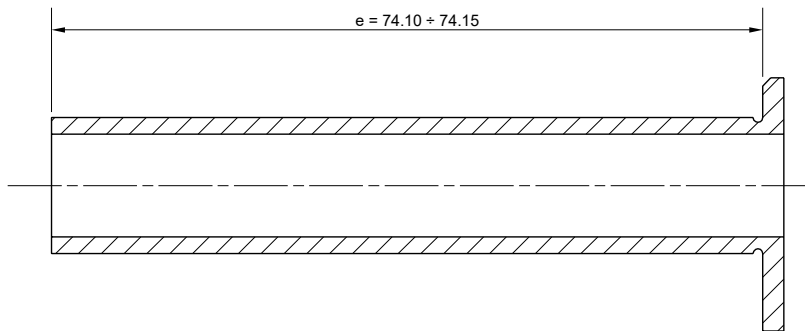
SECTION B-B

**Figure B2**

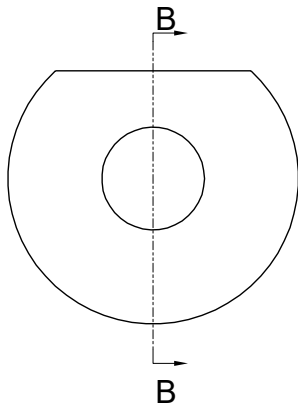
### Rotary Scissor Sleeve



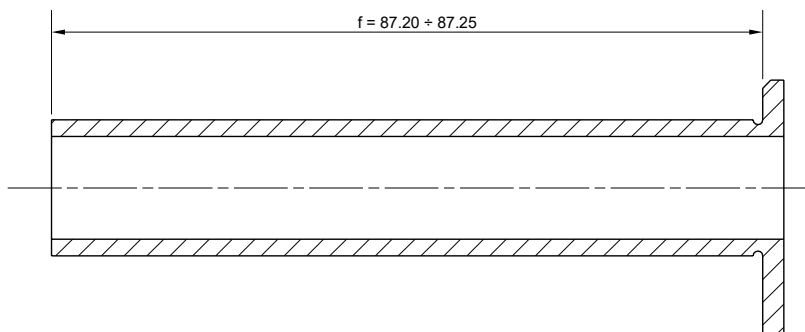
SIDE VIEW



SECTION A-A



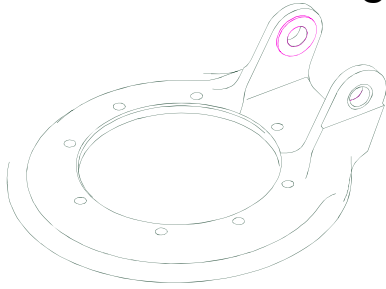
SIDE VIEW



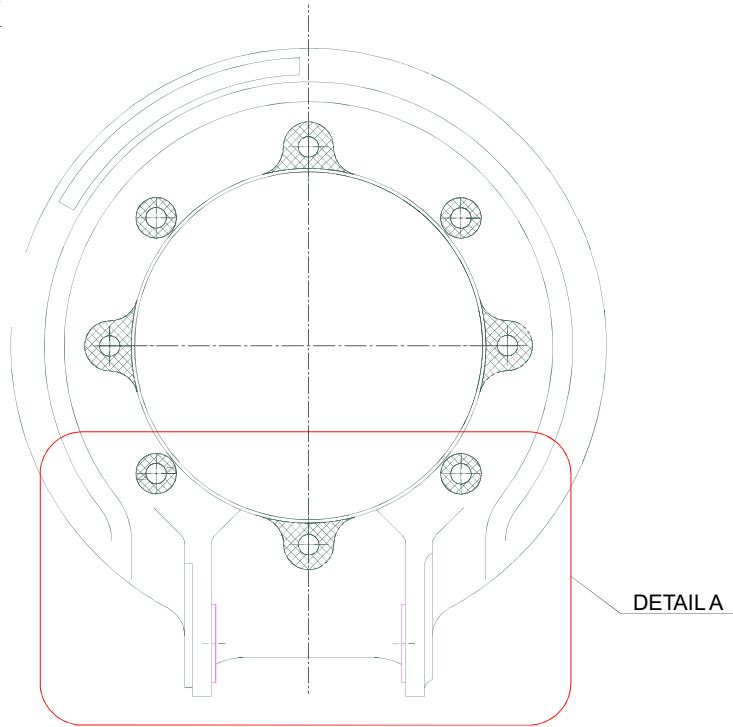
SECTION B-B

**Figure B3**

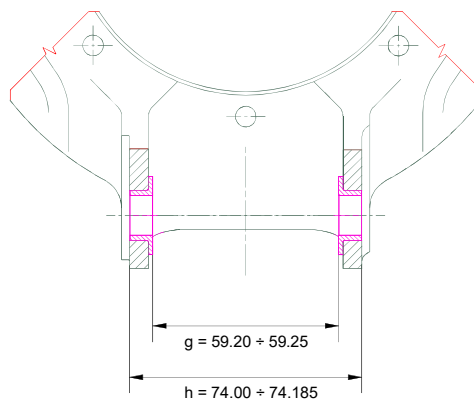
### Scissor Bracket Flange Assy



ISO VIEW



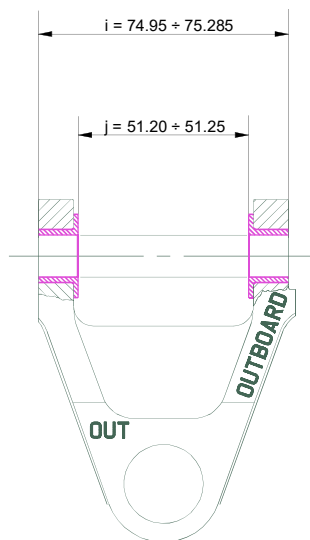
TOP VIEW



DETAIL A

**Figure B4**

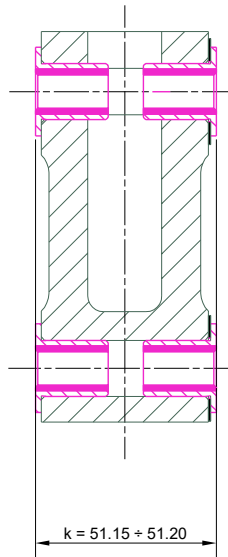
# Lower Scissor Lever Assy



**Figure B5**

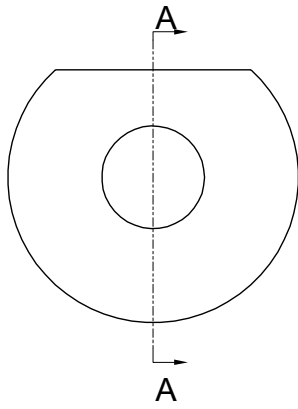
S.B. N°109EP-177 ALERT  
DATE: January 11, 2022  
REVISION: /

# Upper Scissor Lever Assy

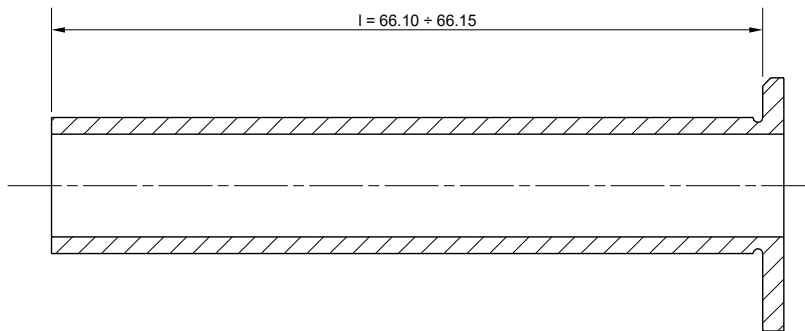


**Figure B6**

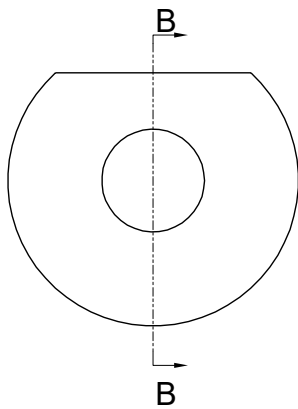
### Rotary Scissor Sleeve



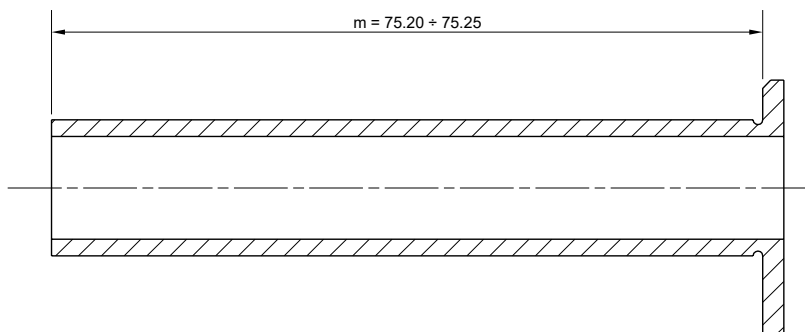
SIDE VIEW



SECTION A-A



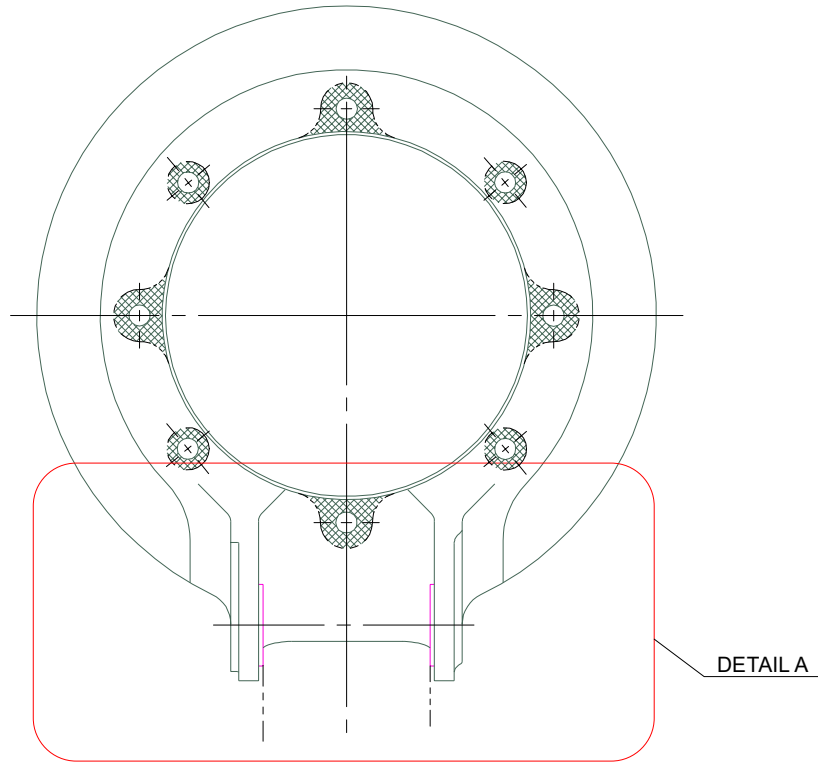
SIDE VIEW



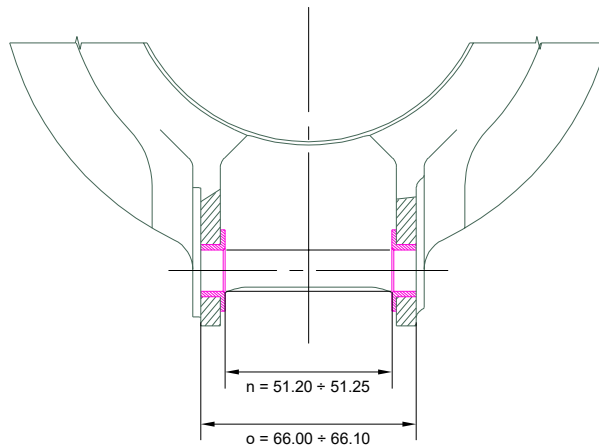
SECTION B-B

**Figure B7**

# Scissor Bracket Flange Assy



TOP VIEW



DETAIL A

**Figure B8**

# **ANNEX C**

## **M/R ROTATING SCISSOR AXIAL PLAY CHECK ON BOARD THE HELICOPTER**



## 1 PURPOSE AND APPLICABILITY

This procedure details the instructions to perform the axial play check of the ball bearing P/N NHBY6V204 directly on board the helicopter.

## 2 EQUIPMENT AND MATERIALS

The following materials, equipment and tools are requested.

### 2.1 MATERIALS

N.A.

### 2.2 EQUIPMENT/TOOLS

- a. Support Arm, Dial Gauge
- b. Dial Gauge
- c. Extension Dial Gauge
- d. Support Dial Gauge

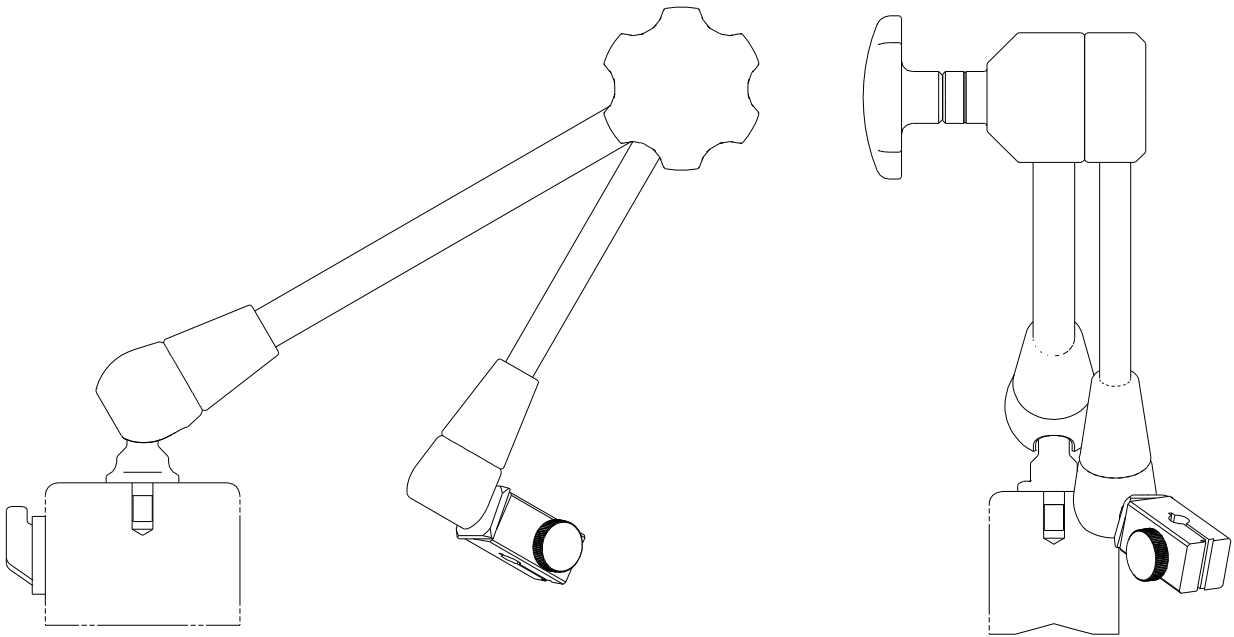
## 3 AXIAL PLAY CHECK INSTRUCTION

### NOTE

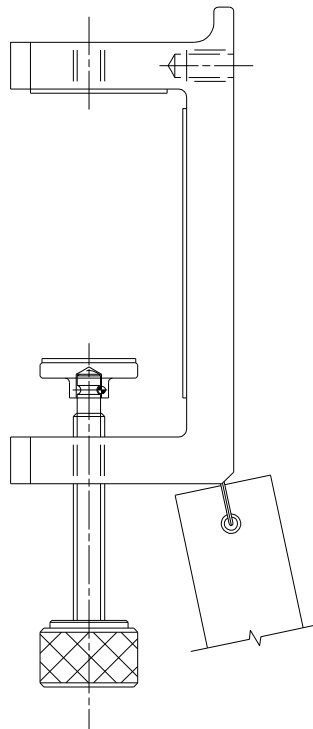
An axial play greater than 0.25 mm is considered temporary acceptable following inspection requirements detailed in Part II of this Service Bulletin.

- 3.1 Install the support arm dial gauge P/N 3G6005G04751 or equivalent (Figure C1 for reference) on the dial gauge P/N 1502251, provided of the extension dial gauge P/N 1500019.
- 3.2 Install the support arm with the dial gauge on the support dial gauge P/N 3G6005G01531 or equivalent (Figure C1 for reference).
- 3.3 As showed in the red box in Figure C2, install the support dial gauge in its position on the pitch control lever.
- 3.4 As showed in the red box in Figure C3, put the plunger of the dial gauge against the lower part of the lower scissor lever, just below the ball bearing. Hold the dial gauge in that position on the pitch control lever.
- 3.5 Push and pull by hand the lower scissor lever along the bearing axis.
- 3.6 The axial play measurement shall be obtained summing the total displacements, between pushing and pulling, showed on the dial gauge.
- 3.7 An axial play value greater than 0.25 mm is considered not conformant to the requirements.
- 3.8 Remove the dial gauge and the applicable supports from the pitch control lever.

ANNEX C

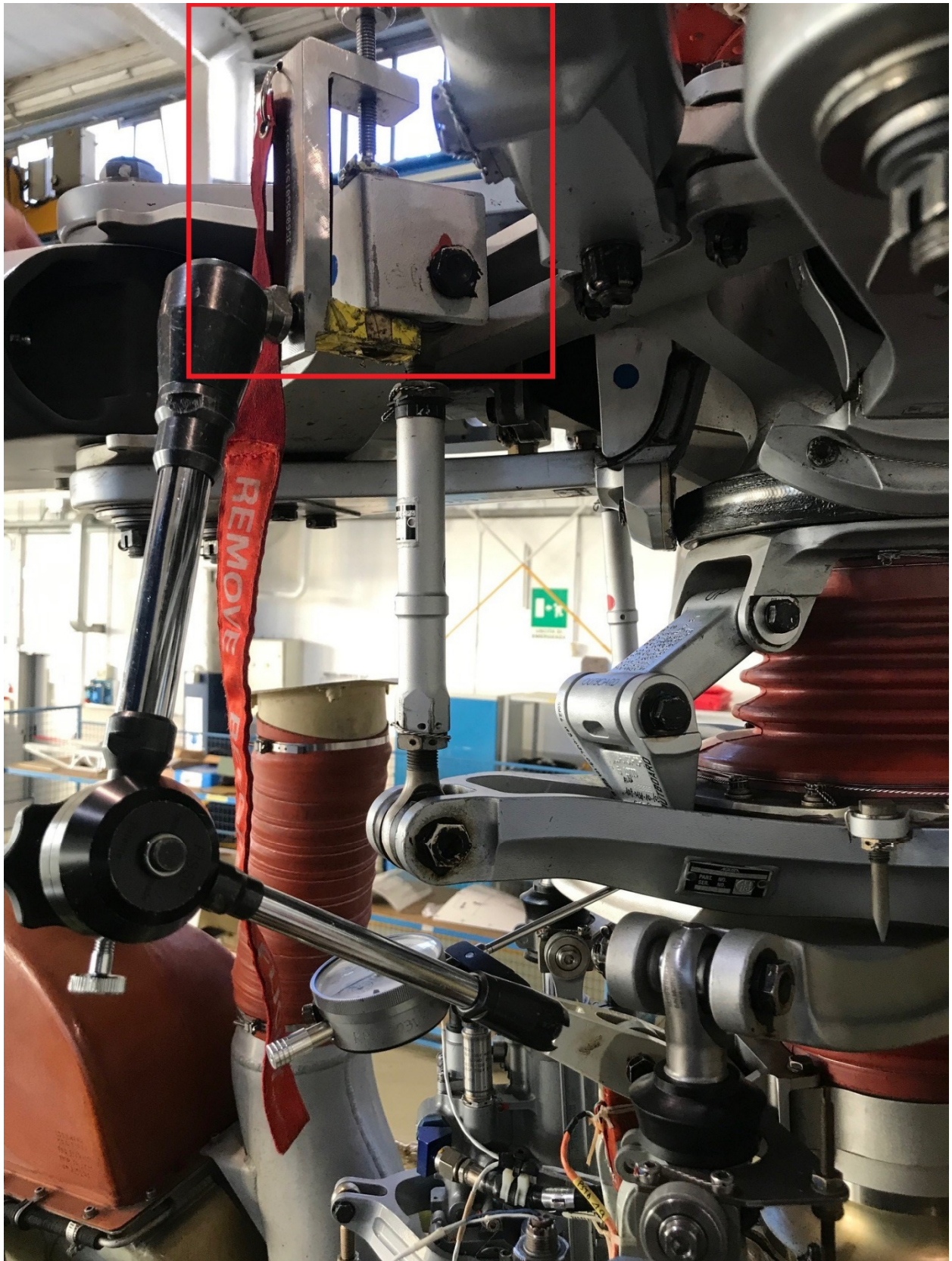


**3G6005G04751**  
**SUPPORT ARM, DIAL GAUGE**  
**(FOR REFERENCE)**



**3G6005G01531**  
**SUPPORT DIAL GAUGE**  
**(FOR REFERENCE)**

**Figure C1**



For reference only

**Figure C2**



For reference only

Figure C3

S.B. N°109EP-177 ALERT  
DATE: January 11, 2022  
REVISION: /

# ANNEX D

## M/R ROTATING SCISSOR AXIAL PLAY CHECK ON GROUND

## 1 PURPOSE AND APPLICABILITY

This procedure details the instructions to perform the axial play check of the ball bearing P/N NHBY6V204 on ground.

## 2 AXIAL PLAY CHECK INSTRUCTION

### NOTE

An axial play greater than 0.25 mm is considered temporary acceptable following inspection requirements detailed in Part II of this Service Bulletin.

### NOTE

To perform the axial play check as per step 2.2, it is required to remove the rotating scissor assy from the helicopter. No disassembly required.

- 2.1 With reference to MM Paragraph 62-31-15, remove the M/R rotating scissor assy from the helicopter. Discard the nut P/N MS17825-6 that attaches the upper scissor lever to the flange assy.
- 2.2 With reference to MM Paragraph 62-31-16, perform the axial play check of the ball bearing P/N NHBY6V204.
- 2.3 With reference to MM paragraph 62-31-15, reinstall the rotating scissor assy with the new nut.

# ANNEX E

## DETAILED COMPLIANCE FORM

Please send to the following address <b>LEONARDO S.p.A.</b> <b>CUSTOMER SUPPORT &amp; SERVICES - ITALY</b> <b>PRODUCT SUPPORT ENGINEERING &amp; LICENSES DEPT.</b> Via Giovanni Agusta, 520 21017 Cascina Costa di Samarate (VA) - ITALY Tel.: +39 0331 225036 Fax: +39 0331 225988		<b>DETAILED COMPLIANCE FORM</b>		<b>DATE</b>	
		Number: S.B. N°109EP-177			
		Revision: /			
Customer Name and Address:		Telephone:			
		Fax:			
		S.B. Compliance Date:			
<b>Helicopter Model</b>	<b>S/N</b>	<b>Aircraft FH</b>	<b>Lower Scissor Lever Assy FH</b>	<b>Upper Scissor Lever Assy FH</b>	<b>T.S.O.</b>
<b>Lower Scissor Lever Assy P/N</b>		<b>S/N</b>			
<b>Upper Scissor Lever Assy P/N</b>		<b>S/N</b>			
<b>Part I</b>					
<b>Part I Step 2 - SCISSOR COUPLING CHECK</b>					
<b>Part I Step 2.1 - REFERENCE VALUE FORCE CHECK (Refer to Annex A Step 3)</b>					
<b>STEP</b>		<b>RECORDED VALUE</b>			
Annex A, Step 3.2.2 - Upper Scissor Lever assy P/N 109-0134-23-105 or 109-8110-16-1					



Annex A Step 3.2.4 - Lower Scissor Lever assy P/N 109-0134-25-101 or 109-0134-10-105 or 109-0134-10-101			
<b>Part I Step 2.2 - MAXIMUM TORQUE FORCE CHECK (Refer to Annex A Step 4)</b>			
STEP	THRESHOLD	RECORDED VALUE	PASSED / FAILED
Annex A Step 4.1.4 - Upper Scissor Lever assy P/N 109-0134-23-105 or 109-8110-16-1	$\leq 6.7$ N		
Annex A Step 4.1.6 - Lower Scissor Lever assy P/N 109-0134-25-101 or 109-0134-10-105 or 109-0134-10-101	$\leq 3.1$ N		
<b>MAXIMUM TORQUE FORCE CHECK PASSED / FAILED <sup>(1)</sup></b>			
<b>Part I Step 2.3 - DIMENSIONAL CHECK <sup>(2)</sup> (Refer to Annex B)</b>			
STEP	THRESHOLD	RECORDED VALUES	PASSED / FAILED
Annex B Step 3.3.1 - Lower Scissor Lever assy P/N 109-0134-25-101	63.15 - 63.20 mm		(3)
Annex B Step 3.3.2 - Upper Scissor Lever assy P/N 109-0134-23-105	59.15 - 59.20 mm		(3)
Annex B Step 3.3.3 - Upper Scissor Lever assy P/N 109-0134-23-105	63.20 - 63.25 mm		(3)
Annex B Step 3.3.4 - Upper Scissor Lever assy P/N 109-0134-23-105	86.95 - 87.285 mm		(3)

## ANNEX E

			(3)
Annex B Step 3.3.5 - Rotary Scissor Sleeve P/N 109-0110-69-109	74.10 - 74.15 mm		(3)
Annex B Step 3.3.6 - Rotary Scissor Sleeve P/N 109-0110-69-111	87.20 - 87.25 mm		(3)
Annex B Step 3.3.7 – Scissor Bracket Flange assy P/N 109-0111-49-101	59.20 - 59.25 mm		(3)
Annex B Step 3.3.8- Scissor Bracket Flange assy P/N 109-0111-49-101	74.00 - 74.185 mm		(3)
Annex B Step 3.3.9 - Lower Scissor Lever assy P/N 109-0134-10-105 or 109-0134-10-101	74.95 - 75.285 mm		(3)
Annex B Step 3.3.10 - Lower Scissor Lever assy P/N 109-0134-10-105 or 109-0134-10-101	51.20 - 51.25 mm		(3)
Annex B Step 3.3.11 - Upper Scissor Lever assy P/N 109-8110-16-1	51.15 - 51.20 mm		(3)

Annex B Step 3.3.12 - Rotary Scissor Sleeve P/N 109-0110-69-105	66.10 - 66.15 mm		(3)
Annex B Step 3.3.13 - Rotary Scissor Sleeve P/N 109-0110-69-107	75.20 - 75.25 mm		(3)
Annex B Step 3.3.14 - Scissor Bracket Flange assy P/N 109-0111-11-105	51.20 - 51.25 mm		(3)
Annex B Step 3.3.15 - Scissor Bracket Flange assy P/N 109-0111-11-105	66.00 - 66.10 mm		(3)
<b>DIMENSIONAL CHECK PASSED / FAILED <sup>(4)</sup></b>			
<b>Part I Step 2.6 – 2<sup>nd</sup> MAXIMUM TORQUE FORCE CHECK (Refer to Annex A Step 4)</b>			
STEP	THRESHOLD	RECORDED VALUES	PASSED / FAILED
Annex A Step 4.1.4 - Upper Scissor Lever assy P/N 109-0134-23-105 or 109-8110-16-1	≤6.7 N		

Annex A Step 4.1.6 - Lower Scissor Lever assy P/N 109-0134-25-101 or 109-0134-10-105 or 109- 0134-10-101	≤3.1 N		
<b>2<sup>ND</sup> MAXIMUM TORQUE FORCE CHECK PASSED / FAILED <sup>(1)</sup></b>			
<b>SCISSOR COUPLING CHECK OUTCOME: PASSED / FAILED <sup>(5)</sup></b>			
<b>Part I Step 3 - AXIAL PLAY CHECK (Refer to Annex C or D)</b>			
<b>STEP</b>	<b>THRESHOLD</b>	<b>RECORDED VALUES</b>	<b>PASSED / FAILED</b>
Annex C Step 3 or Annex D Step 2 –  Ball Bearing P/N NHBV6V204	≤0.25 mm		
<b>AXIAL PLAY CHECK PASSED / FAILED <sup>(6)</sup></b>			
<b>NOTES</b>			
<p>(1) Maximum Torque Force Check is considered PASSED if the checks 4.1.4 and 4.1.6 in Annex A are both PASSED.</p> <p>(2) Dimensional Check i.a.w. step 3.3 in Annex B is required only if Maximum Torque Force Check i.a.w. step 4.1 in Annex A is FAILED.</p> <p>(3) Checks 3.3.1 thru 3.3.15 in Annex B are considered PASSED if all four measures are within threshold.</p> <p>(4) Dimensional Check is considered PASSED if the checks 3.3.1 thru 3.3.8 (for helicopters installing the rotating scissor assy P/N 109-0134-21-103) or 3.3.9 thru 3.3.15 (for helicopters installing the rotating scissor assy P/N 109-0134-09-101) in Annex B are all PASSED. If the Dimensional Check is PASSED, perform a 2<sup>ND</sup> Maximum Torque Force Check.</p> <p>(5) Scissor Coupling Check is considered PASSED if Maximum Torque Force Check, and Dimensional Check (if required), are PASSED (see Table E1)</p> <p>(6) Axial Play Check is considered PASSED if the check 3 in Annex C or 2 in Annex D is PASSED.</p>			

<b>SCISSOR COUPLING CHECK OUTCOME REFERENCE TABLE</b>			
<b>MAXIMUM TORQUE FORCE CHECK</b>	<b>DIMENSIONAL CHECK</b>	<b>2<sup>ND</sup> MAXIMUM TORQUE FORCE CHECK</b>	<b>SCISSOR COUPLING CHECK OUTCOME</b>
PASSED	N/A	N/A	<b>PASSED</b>
FAILED	PASSED	PASSED	<b>PASSED</b>
FAILED	FAILED	N/A	<b>FAILED</b>
FAILED	PASSED	FAILED	<b>UNCERTAIN RESULT: CONTACT LEONARDO HELICOPTERS</b>

**Table E1**

Please send to the following address:  <b>LEONARDO S.p.A.</b> CUSTOMER SUPPORT & SERVICES - ITALY  PRODUCT SUPPORT ENGINEERING & LICENSES DEPT. Via Giovanni Agusta, 520 21017 Cascina Costa di Samarate (VA) - ITALY Tel.: +39 0331 225036 Fax: +39 0331 225988	<b>SERVICE BULLETIN COMPLIANCE FORM</b>	Date:
	Number:	
	Revision:	

Customer Name and Address:	Telephone:
	Fax:
	B.T. Compliance Date:

Helicopter Model	S/N	Total Number	Total Hours	T.S.O.

Remarks:

Information:

We request your cooperation in filling this form, in order to keep our statistical data relevant to aircraft configuration up-to-date. The form should be filled in all its parts and sent to the above address or you can communicate the application also via Technical Bulletin Application Communication Section placed in Leonardo AW Customer Portal - MyCommunications Area. We thank you beforehand for the information given.