SERVICE BULLETIN

N° 109EP-173

ALERT

DATE: November 10, 2020

REV. : B - August 24, 2023

TITLE

**ATA 53 - CENTRAL FUSELAGE FRAME ASSY AT STA 1815, INSPECTION, REPAIR
AND REINFORCEMENT OF**

REVISION LOG

Revision B is issued in order to introduce the following changes:

- Amend minor errors;
- Introduce Part IV and Part V.

Revision bars identify changes.

1. PLANNING INFORMATION

A. EFFECTIVITY

All the A109E helicopters from S/N 11001 thru S/N 11674 included.

B. COMPLIANCE

NOTE

The helicopter's posts that have been repaired in accordance with Part II (LH side) or Part III (RH side) of this Service Bulletin, or in accordance with repair drawing P/N 109-0952-67-117 (LH side) or P/N 109-0952-67-102 (RH side), shall be inspected in accordance with Part I after they have accumulated more than 1000 FH or 3500 landings since repair.

NOTE

The helicopter's posts that have been reinforced in accordance with Part IV (LH side) or Part V (RH side) of this Service Bulletin are no longer affected by the relevant inspection (ref. Part I).

Helicopter that have accumulated more than 1000FH or 3500 landings, whichever occurs first:

- PART I:
Within and not later than 100FH from the issuance of this SB and every 100FH thereafter.
- PART II AND PART III:
 - Within and not later than the next 25FH if the length of crack on the FWD CAP does not exceed 50 mm and no other damages are detected in the affected area.

NOTE

If the length of the cracks exceeds the boundaries of the FWD CAP, INNER FORWARD ANGLE or WEB (ref. Figure 1), the repair scheme reported in Part II and III of this Service Bulletin could not be applicable. In this case contact Leonardo Engineering Dept engineering.support.lhd@leonardo.com before the next flight.

- Before the next flight if the length of crack on the FWD CAP is greater than 50 mm and/or any other crack(s) are detected.
- PART IV AND PART V:
Within and not later than August 31, 2026.

Helicopter that have accumulated up to 1000FH or 3500 landings, whichever occurs first:

- PART I:
Within and not later 100FH upon the achievement of 1000FH or 3500 landings and every 100FH thereafter.
- PART II AND PART III:
 - Within and not later than the next 25FH if the length of crack on the FWD CAP does not exceed 50 mm and no other damages are detected in the affected area.

NOTE

If the length of the cracks exceeds the boundaries of the FWD CAP, INNER FORWARD ANGLE or WEB (ref. Figure 1), the repair scheme reported in Part II and III of this Service Bulletin could not be applicable. In this case contact Leonardo Engineering Dept engineering.support.lhd@leonardo.com before the next flight.

- Before the next flight if the length of crack on the FWD CAP is greater than 50 mm and/or any other crack(s) are detected.
- PART IV AND PART V:
Within and not later than August 31, 2026.

C. CONCURRENT REQUIREMENTS

N.A.

D. REASON

This Service Bulletin is issued in order to provide the necessary instruction on how to perform an inspection to detect cracks in the center fuselage at intersection of lateral pylon (LH and RH side) with floor spar, and, in case of findings, to repair it. Moreover, the instructions for corrective actions (reinforcements) are provided.

E. DESCRIPTION

Some occurrences of cracks have been found in the fuselage of the Leonardo S.p.a. A109E helicopters at the intersection of the lateral pylon with the floor spar at the STA 1815, either in the LH and RH side.

In Part I of this Service Bulletin are given the instruction to perform an inspection in the area affected by the possible cracks, in Part II are given the instruction for LH side fuselage repair and in Part III are given the instruction for RH side fuselage repair.

Revision B is issued to provide the instruction for LH side fuselage reinforcement (Part IV) and for RH side fuselage reinforcement (Part V).

F. APPROVAL

The technical content of this Service Bulletin is approved under the authority of DOA nr. EASA.21.J.005. For helicopters registered under other Aviation Authorities, before applying the Service Bulletin, applicable Aviation Authority approval must be checked with Local Aviation Authority.

EASA states mandatory compliance with inspections, modifications or technical directives and related time of compliance by means of relevant Airworthiness Directives. If an aircraft listed in the effectivity embodies a modification or repair not LHD certified and affecting the content of this Service Bulletin, it is responsibility of the Owner/Operator to obtain a formal approval by Aviation Authority having jurisdiction on the aircraft, for any adaptation necessary before incorporation of the present Service Bulletin.

G. MANPOWER

To comply with this Service Bulletin the following MMH are deemed necessary:

Part I: approximately 6 (six) hours;

Part II: approximately 120 (one hundred and twenty) hours;

Part III: approximately 120 (one hundred and twenty) hours.

Part IV: approximately 120 (one hundred and twenty) hours;

Part V: approximately 120 (one hundred and twenty) hours.

MMH are based on hands-on time and can change with personnel and facilities available.

H. WEIGHT AND BALANCE

PART I, II and III:

N.A.

PART IV

WEIGHT (kg)	ARM (mm)	MOMENT (kgmm)
		0.91
LONGITUDINAL BALANCE	1880	1710

PART V

Negligible.

I. REFERENCES

I.1 PUBLICATIONS

<u>DATA MODULE</u>	<u>DESCRIPTION</u>	<u>PART</u>
DM01 00-20-1	Helicopter safety	All
DM02 06-40-1	Access panels and doors	II, III, IV, V
DM03 00-10-4	Connection/disconnection of external electrical power	II, III, IV, V
DM04 00-10-8	Connection/disconnection of external hydraulic power	II, III, IV, V
DM05 25-11-9	Crew seats - removal/installation	II, III, IV, V
DM06 25-21-12	Forward seat - removal/installation	II, III, IV, V
DM07 21-21-1	Air distribution system	II, III, IV, V
DM08 52-11-9	LH/RH cockpit doors - removal/installation	II, III, IV, V
DM09 67-11-1	Collective pitch control system	II, IV
DM10 67-11-9	Collective pitch control lever - removal/installation	II, IV
DM11 25-81-7	Cockpit soundproofing panels - removal/installation	All
DM12 25-81-9	Passenger soundproofing panels - removal/installation	All
DM13 52-71-6	Operational test of cockpit/passenger compartment caution system	II, III, IV, V
DM14 67-12-1	Cyclic pitch control system	III, V
DM15 67-00-12	Control tube - general maintenance	II, III, IV, V
DM16 07-30-1	Hoisting of complete helicopter	II, III, IV, V
DM17 07-30-2	Hoisting of helicopter without main rotor	II, III, IV, V
DM18 67-00-25	Collective pitch control adjustment	II, IV
DM19 67-00-26	Cyclic pitch control adjustment	III, V

I.2 ACRONYMS

AR	As Required
DOA	Design Organization Approval
EASA	European Aviation Safety Agency
LHD	Leonardo Helicopters Division
LS	Local Supply
DM	Data Module
FH	Flight Hours
MMH	Maintenance Man Hours

N.A. Not Applicable
P/N Part Number
SB Service Bulletin
S/N Serial Number

I.3 ANNEX

N.A.

J. PUBLICATIONS AFFECTED

A109E-MM Maintenance Manual A109E Helicopter Model.

A109E-MPM Maintenance Planning Manual A109E Helicopter Model.

3C-A-ASRP-00-X - AW119/A109 Series Air Vehicle Structural Repair Publication.

K. SOFTWARE ACCOMPLISHMENT SUMMARY

N.A.

2. MATERIAL INFORMATION

A. REQUIRED MATERIALS

A.1 PARTS

PART I

N.A.

PART II

#	P/N	ALTERNATIVE P/N	DESCRIPTION	Q.TY	LVL	NOTE	LOG P/N
1	109-0952-67-117		REPAIR ASSY, LH	REF	.		-
2	109-0320-90-207	109-0320-90-207A1	Cap, forward LH	1	..	(1)	-
3	109-0320-90-7		Panel	REF	..	(1)(2)	-
4	109-0320-90-507		Cap, forward LH	1	..	(3)	-
5	109-0320-90-505		Panel	REF	..	(3)(4)	-
6	109-0952-67-119		Angle	1	..	(17)	709-052L1
7	109-0952-67-121		Internal butt-strap	1	..		709-052L1
8	109-0952-67-123		External butt-strap	1	..		709-052L1
9	109-0952-67-125		Web	1	..	(18)	709-052L1
10	109-0360-88-109		Seal assy, co-pilot door	1	..	(5)	709-052L1
11	A233A001B	AW004FE001B	Fastener, seal	36	..		709-052L1
12	109-0360-86-109		Seal assy, LH passenger door	1	..	(5)	709-052L1
13	A879A05L150		Rivet, solid	5	..		709-052L1
14	MS27039-1-08		Screw	8	..		709-052L1
15	MS20426AD3-5		Rivet, solid, 100° countersunk head	0.1kg	..		709-052L1
16	MS20426AD3-6		Rivet, solid, 100° countersunk head	0.1kg	..		709-052L1
17	MS20426AD4-5		Rivet, solid, 100° countersunk head	0.1kg	..		709-052L1
18	MS20426AD5-5		Rivet, solid, 100° countersunk head	0.1kg	..		709-052L1
19	MS20426AD5-6		Rivet, solid, 100° countersunk head	0.1kg	..		709-052L1
20	MS20426AD5-8		Rivet	0.1kg	..		709-052L1
21	MS20426AD5-9		Rivet	0.1kg	..		709-052L1
22	MS20470AD5-5		Rivet, solid, universal head	0.1kg	..		709-052L1
23	MS20470AD5-6		Rivet, solid, universal head	0.1kg	..		709-052L1
24	MS20470AD5-7		Rivet	0.1kg	..		709-052L1
25	MS21069L08		Nut plate, self-locking	1	..		709-052L1
26	MS21071L08		Nut plate, self-locking	1	..		709-052L1
27	NAS9301B-4-02		Rivet, blind, protruding head	100	..		709-052L1
28	NAS9301B-4-03		Rivet, blind, protruding head	20	..		709-052L1
29	NAS9301B-4-04		Rivet, blind, protruding head	10	..		709-052L1
30	MS24665-151		Cotter Pin	2	..		709-052L1
31	MS24665-155		Cotter Pin	2	..		709-052L1
32	MS20615-4M3		Rivet, universal head	0.1kg	..		709-052L1
33	MS20427M4-3		Rivet, 100° countersunk head	0.1kg	..		709-052L1
34	MS20600AD4-3	MS20600AD4W3	Rivet, blind	80	..		709-052L1
35	NAS1720H4L4A		Rivet, blind	80	..		709-052L1
36	NAS1721H4L2A		Rivet, blind	30	..		709-052L1

#	P/N	ALTERNATIVE P/N	DESCRIPTION	Q.TY	LVL	NOTE	LOG P/N
37	NAS1721H4L4A		Rivet, blind	20	..		709-052L1

PART III

#	P/N	ALTERNATIVE P/N	DESCRIPTION	Q.TY	LVL	NOTE	LOG P/N
38	109-0952-67-102		REPAIR ASSY, RH	REF	.		-
39	109-0320-90-208	109-0320-90-208A1	Cap, forward RH	1	..		709-052L2
40	109-0320-90-8		Panel	REF	..	(6)	-
41	109-0952-67-111		Angle	1	..	(16)	709-052L2
42	109-0952-67-113		Internal butt-strap	1	..		709-052L2
43	109-0952-67-115		External butt-strap	1	..		709-052L2
44	109-0952-67-109		Web	1	..	(15)	709-052L2
45	109-0360-88-110		Seal assy, co-pilot door	1	...	(7)	709-052L2
46	A233A001B	AW004FE001B	Fastener, seal	36	..		709-052L2
47	109-0360-86-110		Seal assy, LH passenger door	1	..	(7)	709-052L2
48	A879A05L150		Rivet, solid	5	..		709-052L2
49	MS20426AD4-5		Rivet, solid, 100° countersunk head	0.1kg	..		709-052L2
50	MS20470AD5-5		Rivet, solid, universal head	0.1kg	..		709-052L2
51	MS20470AD5-6		Rivet, solid, universal head	0.1kg	..		709-052L2
52	MS20470AD5-7		Rivet	0.1kg	..		709-052L2
53	MS20470AD5-8		Rivet	0.1kg	..		709-052L2
54	MS20470AD5-9		Rivet	0.1kg	...		709-052L2
55	NAS9301B-4-02		Rivet, blind, protruding head	100	..		709-052L2
56	NAS9301B-4-03		Rivet, blind, protruding head	20	..		709-052L2
57	NAS9301B-4-04		Rivet, blind, protruding head	10	..		709-052L2
58	MS24665-151		Cotter Pin	4	..		709-052L2
59	MS20615-4M3		Rivet, universal head	0.1kg	..		709-052L2
60	MS20615-4M4		Rivet, 100° countersunk head	0.1kg	..		709-052L2
61	MS20600AD4-3	MS20600AD4W3	Rivet, blind	80	..		709-052L2
62	NAS1720H4L4A		Rivet, blind	80	..		709-052L2
63	NAS1721H4L2A		Rivet, blind	30	...		709-052L2
64	NAS1721H4L4A		Rivet, blind	20	..		709-052L2

PART IV

#	P/N	ALTERNATIVE P/N	DESCRIPTION	Q.TY	LVL	NOTE	LOG P/N
65	109G5330R01-201		LATERAL MOUNTING REINFORCEMENT	REF	.		-
66	109-0320-90-207	109-0320-90-207A1	Cap, forward LH	1	..	(1)(12)	709-052L3
67	109-0320-90-7		Panel	REF	..	(1)(2)	-
68	109-0320-90-507		Cap, forward LH	1	..	(3)(12)	-
69	109-0320-90-505		Panel	REF	..	(3)(4)	-
70	109-0952-67-123		External Butt-Strap	1	..		709-052L3
71	109-0952-67-125		Web	1	..	(12)(18)	709-052L3
72	109G5307P39-113		Angle LH	1	..		709-052L3
73	109G5307P39-115		Left Cap	1	..		709-052L3
74	109G5307P39-117		Doubler	1	..		709-052L3
75	109G5330A25-101		Stiffener Machined LH	1	..		709-052L3
76	109G5330R01-205		Doubler LH	1	..		709-052L3
77	A879A05L150		Rivet	6	..		709-052L3
78	CR2245-4-2		Rivet	1	..		709-052L3
79	CR2245-4-5		Rivet	2	..		709-052L3

#	P/N	ALTERNATIVE P/N	DESCRIPTION	Q.TY	LVL	NOTE	LOG P/N
80	CR2245-5-3		Rivet	1	..		709-052L3
81	MS20426AD3-5		Rivet	0.1kg	..		709-052L3
82	MS20426AD4-5		Rivet	0.1kg	..		709-052L3
83	MS20426AD5-5		Rivet	0.1kg	..		709-052L3
84	MS20470AD4-5		Rivet	0.1kg	..		709-052L3
85	MS20470AD5-5		Rivet	0.1kg	..		709-052L3
86	MS21071L08		Nut Plate	2	..		709-052L3
87	NAS1739B4-3		Rivet	8	..		709-052L3
88	NAS9301B-4-02		Rivet	80	..		709-052L3
89	NAS9301B-4-03		Rivet	28	..		709-052L3
90	NAS9301B-4-04		Rivet	12	..		709-052L3
91	NAS9301B-5-02		Rivet	12	..		709-052L3
92	NAS9301B-5-03		Rivet	10	..		709-052L3
93	NAS9301B-5-04		Rivet	10	..		709-052L3
94	109G5330R01-203		ANGLE REPAIR INSTALLATION LH	REF	..		-
95	109-0952-67-119		Angle	1	...	(12)(17)	709-052L3
96	109-0952-67-121		Internal Butt-Strap	1	...		709-052L3
97	MS20470AD5-5		Rivet	0.1kg	...		709-052L3

PART V

#	P/N	ALTERNATIVE P/N	DESCRIPTION	Q.TY	LVL	NOTE	LOG P/N
98	109G5330R01-202		LATERAL MOUNTING REINFORCEMENT	REF	.		-
99	109-0320-90-208	109-0320-90-208A1	FWD Cap RH	1	..	(12)	709-052L3
100	109-0320-90-8		Panel	REF	..	(6)	-
101	109-0952-67-109		Web	1	..	(12)(15)	709-052L3
102	109-0952-67-115		External Butt-Strap	1	..		709-052L3
103	109G5307P39-114		Angle LH	1	..		709-052L3
104	109G5307P39-116		Left Cap	1	..		709-052L3
105	109G5307P39-117		Doubler	1	..		709-052L3
106	109G5330A25-102		Stiffener Machined LH	1	..		709-052L3
107	109G5330R01-206		Doubler LH	1	..		709-052L3
108	A879A05L150		Rivet	6	..		709-052L3
109	CR2245-4-2		Rivet	1	..		709-052L3
110	CR2245-4-5		Rivet	2	..		709-052L3
111	CR2245-5-3		Rivet	1	..		709-052L3
112	MS20426AD3-5		Rivet	0.1kg	..		709-052L3
113	MS20426AD4-5		Rivet	0.1kg	..		709-052L3
114	MS20426AD5-5		Rivet	0.1kg	..		709-052L3
115	MS20470AD4-5		Rivet	0.1kg	..		709-052L3
116	MS20470AD5-5		Rivet	0.1kg	..		709-052L3
117	MS21071L08		Nut Plate	2	..		709-052L3
118	NAS1739B4-3		Rivet	8	..		709-052L3
119	NAS9301B-4-02		Rivet	80	..		709-052L3
120	NAS9301B-4-03		Rivet	28	..		709-052L3
121	NAS9301B-4-04		Rivet	12	..		709-052L3
122	NAS9301B-5-02		Rivet	12	..		709-052L3
123	NAS9301B-5-03		Rivet	10	..		709-052L3
124	NAS9301B-5-04		Rivet	10	..		709-052L3
125	109G5330R01-204		ANGLE REPAIR INSTALLATION LH	REF	..		-
126	109-0952-67-111		Angle	1	...	(12)(16)	709-052L3
127	109-0952-67-113		Internal Butt-Strap	1	...		709-052L3
128	MS20470AD5-5		Rivet	0.1kg	...		709-052L3

A.2 CONSUMABLES

The following consumable materials, or equivalent, are necessary to accomplish this Service Bulletin:

#	Spec./LHD code number	DESCRIPTION	Q.TY	NOTE	PART
129	199-05-002 TY I, CI 2 (cod. 900000581)	Adhesive EA9309.3NA (C100)	AR	(8)	II, III, IV, V
130	199-05-004 TY II, CI 2 (cod. 900001586)	Sealant PROSEAL 890B2 (C148)	AR	(8)(11)	II, III, IV, V
131	AWMS05-001TY I, CI B, Gr 2 (cod. 99999999000015245)	Sealant MC780 B-2 (C501)	AR	(8)(11)	II, III, IV, V
132	MIL-PRF-23377 TY I, CI C2 (cod. 99999999000010181)	Primer, epoxy-polyamide (446)	AR	(8)	II, III, IV, V
133	Commercial	Soft lint-free cloth (011)	AR	(8)	All
134	MIL-PRF-680 TY II	Cleaning solvent (C287)	AR	(8)	All
135	Commercial	Masking tape (C064)	AR	(8)	II, III, IV, V
136	Commercial	Scotch-Brite (C015)	AR	(8)	II, III, IV, V

Refer also to AMDI for the consumable materials required to comply with the MM Paragraphs referenced in the accomplishment instructions.

A.3 LOGISTIC MATRIX

In order to apply this Service Bulletin, the following Logistic P/N can be ordered in accordance with the applicable notes:

LOGISTIC P/N	Q.TY (PER HELO)	NOTE	PART
709-052L1	1	(9)	II
709-052L2	1	(10)	III
709-052L3	1	(13) (14)	IV, V
109-0320-90-207 or 109-0320-90-207A1	1	(1)	II, IV
109-0320-90-7	1	(1)(2)	II, IV
109-0320-90-507	1	(3)	II, IV
109-0320-90-505	1	(3)(4)	II, IV
109-0320-90-8	1	(6)	III, V
109-0320-90-208 or 109-0320-90-208A1	1	(12)	V

NOTE

- (1) Item required for helicopters from S/N 11001 thru S/N 11600.
- (2) This item can be obtained reworking the existing panel P/N 109-0320-90-7.
- (3) Item required for helicopters from S/N 11601 thru S/N 11674.
- (4) This item can be obtained reworking the existing panel P/N 109-0320-90-505.
- (5) Seal assy co-pilot door P/N 109-0360-88-109 and seal assy LH passenger door P/N 109-0360-86-109 will be obtained from gasket P/N A232A001BB. Q.ty 7 m are required to comply with Part II of this Service Bulletin.
- (6) This item can be obtained reworking the existing panel P/N 109-0320-90-8.
- (7) Seal assy pilot door P/N 109-0360-88-110 and seal assy RH passenger door P/N 109-0360-86-110 will be obtained from gasket P/N A232A001BB. Q.ty 7 m are

required to comply with Part III of this Service Bulletin.

- (8) Local supply.
- (9) Required for LH side fuselage repair.
- (10) Required for RH side fuselage repair.
- (11) These materials are alternatives
- (12) Reuse the removed part if it is not damaged.
- (13) Required for LH side fuselage reinforcement.
- (14) Required for RH side fuselage reinforcement.
- (15) This item can be obtained reworking the existing web P/N 109-0320-96-72.
- (16) This item can be obtained reworking the existing RH angle P/N 109-0320-96-74.
- (17) This item can be obtained reworking the existing LH angle P/N 109-0320-96-73.
- (18) This item can be obtained reworking the existing web P/N 109-0320-96-71.

B. SPECIAL TOOLS

The following special tools, or equivalent, are necessary to accomplish this Service Bulletin:

#	P/N	DESCRIPTION	Q.TY	NOTE	PART
137	109-3000-01-41 or 109-3000-03-143	Flight controls rigging pin set	1	(B1)(B2)	II, III, IV, V
138	GB941-009-000 or equivalent	Hydraulic system test bench	1	(B1)(B2)	II, III, IV, V
139	GPU400 or equivalent	Electric power unit	1	(B1)(B2)	II, III, IV, V
140	109-3900-01-1	Hoisting ring, main transmission	1	(B1)(B2)	II, III, IV, V
141	109-3000-05-101	Minimum collective lever	1	(B1)(B2)	II, IV

Refer also to PTUM for the special tools required to comply with the MM Paragraphs referenced in the accomplishment instructions.

SPECIAL TOOLS NOTE

- (B1) Commercial item used for general maintenance. Local supply.
- (B2) If necessary, please contact Leonardo Helicopters Division order administration to request the tools supply on loan. As soon as the present Service Bulletin is implemented the tools supplied on loan shall be promptly returned to Leonardo Helicopters Division.

C. INDUSTRY SUPPORT INFORMATION

Owners/Operators who comply with the instructions of this Service Bulletin no later than the applicable date in the "Compliance" section will be eligible to receive REQUIRED MATERIALS on free of charge basis, except for Consumable Materials and Special Tools.

NOTE: Customers who fail to comply with the instructions in this Service Bulletin before the compliance date are not eligible for the aforementioned special policy.

Please Issue relevant MMIR form to your Warranty Administration Dpt.

3. ACCOMPLISHMENT INSTRUCTIONS

GENERAL NOTES

- a) Place an identification tag on all components that are re-usable, including the attaching hardware that has been removed to gain access to the modification area and adequately protect them until their later re-use.
- b) Shape the cables in order to prevent interference with the structure and the other existing installations, using where necessary suitable lacing cords.
- c) Exercise extreme care during drilling operations to prevent instruments, cables and hoses damage.
- d) After drilling, remove all swarf and sharp edges. Apply on bare metal a light film of primer unless the hole is used for ground connection.
- e) During the installation of bonding braids or components requiring grounding, clean the surface structure in order to obtain a good ground contact.
- f) Let adhesive cure at room temperature for at least 24 hours unless otherwise specified.
- g) Exposed thread surface and nut must be protected using a layer of tectyl according to MIL-C-16173 grade I.
- h) Refer to CSRP-A-CSRP-00-X for the applicable structural standard practice procedures.
- i) Refer to AMP Chapter 20 for the applicable standard torque values for threaded fasteners.
- j) All lengths are in mm.

PART I

1. In accordance with MM Paragraph 00-20-1, prepare the helicopter on ground for a safe maintenance. Disconnect the battery, all electrical power sources and/or the external power supply.
2. With reference to Figure 1, open both the passenger doors and both the cockpit doors and secure them in opened position to gain access to the indicated areas.
3. If installed, remove any item of furnishing on the passenger compartment that might

- prevent the access to the inspection zone.
4. If installed, in accordance with MM Paragraphs 25-81-7 and 25-81-9, remove the cockpit and passenger compartment soundproofing panels or the moquette lining that might prevent the access to the inspection zone.
 5. With reference with Figure 2, on both lateral posts, remove the access panels on the aft side (P/N 109-0320-96-309 on LH side and P/N 109-0320-96-310 on RH side) and on the inboard side (P/N 109-0320-96-521 on LH side and P/N 109-0320-96-522 on RH side). Retain all the fixing hardware for later reuse.
 6. If necessary, clean the inspection areas using a soft lint-free cloth (not soaked) and cleaning solvent MIL-PRF-680 Type II or equivalent.
 7. With reference to Figure 1, using a bright source of light, visually inspect the whole zone of intersection between the lateral post and the floor spar, on both sides of the fuselage, for evidence of cracks. Pay particular attention to the forward area of the post (toward cockpit) and to inboard side of the post.
 8. In case of no findings, reinstall all the component removed from Step 3 to Step 5 and proceed to Step 10.
 9. In case of findings, in accordance with CSRP standard repair procedures perform a fluorescent liquid penetrant inspection of the crack to determine the exact extent, then stop-drill at both ends of crack to relieve the stresses in the extremities and to prevent any further propagation.
 - 9.1 If the length of crack on the FWD CAP does not exceed 50 mm and no other damages are detected in the affected area, proceed in accordance with PART IV (LH side of fuselage) or PART V (RH side of fuselage) of this Service Bulletin within and not later than the next 25 flight hours otherwise.
 - 9.2 If the length of crack on the FWD CAP is greater than 50 mm and/or any other crack(s) are detected but not exceeding the boundaries of the FWD CAP, INNER FORWARD ANGLE or WEB (ref. Figure 1) proceed in accordance with PART IV (LH side of fuselage) or PART V (RH side of fuselage) of this Service Bulletin before the next flight.
 - 9.3 If the length of the cracks exceeds the boundaries of the FWD CAP, INNER FORWARD ANGLE or WEB (ref. Figure 1), the repair/reinforce scheme reported in this Service Bulletin could not be applicable. In this case contact Leonardo Engineering Dept at the following mail box: engineering.support.lhd@leonardo.com.
 10. Return the helicopter to a ready to flight condition and record for compliance with Part I of this Service Bulletin on the helicopter logbook.

11. Gain access to My Communications section on Leonardo WebPortal and compile the “Service Bulletin Application Communication”.

As an alternative, send the attached compliance form to the following mail box:

engineering.support.lhd@leonardo.com

and (for North, Central and South America) also to:

AWPC.Engineering.Support@leonardocompany.us

PART II

NOTE

If undamaged, parts P/N 109-0320-96-71 (or P/N 109-0320-96-505) and 109-0320-96-73 (or P/N 109-0320-96-507) may not be cut and reused in their respective position.

1. In accordance with MM Paragraph 00-20-1, prepare the helicopter on ground for a safe maintenance. Disconnect the battery, all electrical power sources and/or the external power supply.
2. With reference to Figure 11 and Figure 12, remove the collective control rod assy P/N 109-0032-02-41 and the tail rotor control rod assy P/N 109-0032-02-25 as follows:
 - 2.1 In accordance with MM Paragraph 25-11-9, remove the co-pilot seat.
 - 2.2 If installed, in accordance with MM Paragraph 25-21-12, remove the forward passenger seat.
 - 2.3 In accordance with the pertinent MM Paragraph, remove any other item of equipment/furnishing that might prevent the access to the work area.
 - 2.4 If installed, in accordance with MM Paragraphs 25-81-7 and 25-81-9, remove the cockpit and passenger compartment soundproofing panels or the moquette lining that might prevent the access to the inspection zone.
 - 2.5 In accordance with MM Paragraph 21-21-1, remove the air distribution duct P/N 109-0710-32-105 from the left door post.
 - 2.6 Remove the access panel P/N 109-0320-90-63.
 - 2.7 Remove the access door P/N 109-0322-10-13 on the upper part of the fuselage, over the door post.
 - 2.8 Using masking tape, identify the position and the sense of installation of each control rod assy.
 - 2.9 With reference to Figure 11, on the lower end of the collective control rod assy, remove the cotter pin, the nut, the bolt and the washers that attach the lower end of the control rod assy to the lever. Discard the cotter pin. If necessary, move slightly the collective control lever and/or the pedals to allow an easy removal of the bolt.

CAUTION

During the hardware removing, keep the rod assy to prevent it from falling.

- 2.10 With reference to Figure 11, on the upper end of the collective control rod assy, remove the cotter pin, the nut, the bolt and the washers that attach the upper end of the control rod assy to the lever. Discard the cotter pin.

NOTE

Do not change the length of the collective control rod assy.

CAUTION

Apply the maximum care to prevent any damage to the control rod caused by rubbing with other parts of the helicopter.

- 2.11 Withdraw the collective control rod assy from the upper side of helicopter.
- 2.12 With reference to Figure 12, on the lower end of the tail rotor control rod assy, remove the cotter pin, the nut, the bolt and the washer that attach the lower end of the control rod assy to the lever. Discard the cotter pin.

CAUTION

During the hardware removing, keep the rod assy to prevent it from falling.

- 2.13 With reference to Figure 12, on the upper end of the tail rotor control rod assy, remove, the nut, the bolt and the washer that attach the lower end of the control rod assy to the lever. Discard the cotter pin.

NOTE

Do not change the length of the tail rotor control rod assy.

CAUTION

Apply the maximum care to prevent any damage to the control rod caused by rubbing with other parts of the helicopter.

- 2.14 Withdraw the tail rotor control rod assy from the upper side of helicopter.
3. In accordance with MM Paragraph 52-11-9, remove the pilot and co-pilot door. Open both the passenger compartment doors and lock them in opened position.
4. Remove the co-pilot door seal assy P/N 109-0360-88-109 and the passenger door seal assy P/N 109-0360-86-109. Remove any trace of adhesive and rubber from installation areas using a plastic scraper and a soft cloth moistened with solvent.
5. In accordance with MM Paragraph 25-11-9, remove the pilot seat.
6. Remove the support panels located under the pilot and co-pilot seat. Remove also the

- centre panel located between the seats and any control located on it (e.g. friction knob, cargo hook release handle).
7. If installed, in accordance with MM Paragraphs 67-00-12 and 67-11-9, remove the co-pilot collective control lever.
 8. Set the collective control in fully-up position then lock the collective torque tube using the friction.
 9. Remove the collective lever guard assy P/N 109-0700-25-127 (if the helicopter is equipped with dual control) or the fairing P/N 109-0011-28-1 (if the helicopter is not equipped with dual control).
 10. Remove and retain for later re-use all the access panels located on the door sill.
 11. With reference to Figure 2, remove the access panels P/N 109-0320-96-521 and P/N 109-0320-96-309 located on the post. Retain all the fixing hardware for later reuse.
 12. Remove the air conditioning duct located inside the door lower sill. Cap thoroughly the open ends of the adjacent ducts to prevent any unwanted entry of foreign materials in the air conditioning system.
 13. Remove the collective stick connector located on the right side of the co-pilot seat support structure. Wrap the connector using a plastic sheet and stow it in a safe place.
 14. In accordance with MM Paragraphs 67-00-12 and 67-11-9, remove the collective control torque tube. To make easier the reinstallation of the torque tube at the end of the repair, it is advisable to mark the position of the following components on the torque tube using a thin felt-tip pen:
 - LVDT sensors (collective transducers);
 - Engine-out switch (if installed in accordance with SB 109EP-081);
 - Collective friction;
 - Support on the LH side of the torque tube.
 15. With reference to Figure 13, remove the LH post centre fairing P/N 109-0324-29-101 by removing the related attaching screws.
 16. Remove the cockpit/passenger doors caution system switch from the fairing removed at previous Step 15 by removing the two attaching screws. Leave the switch attached to the wire. Take note of quantity of shims below the switch in order to allow the reinstallation in their original position.
 17. If applied, remove any sill-liner or anti-slip paint from the upper side of the fairings P/N 109-0324-25-303 and 109-0324-30-201.
 18. In accordance with MM Paragraphs 07-30-1 or 07-30-2, raise the helicopter using the lifting device P/N 109-3900-01-1 connected to a suitable crane/hoist and put the cable in tension.

19. With reference to Figure 13, remove the LH lower fairing P/N 109-0324-25-303 by drilling-out the attaching rivets. Break the sealant layer between the fairing and the structure using a thin blade or putty knife.
20. With reference to Figure 13, remove the LH post lower fairing P/N 109-0324-30-201 by drilling-out the attaching rivets. Break the sealant layer between the fairing and the structure using a thin blade or putty knife.
21. Remove any trace of sealant from the structure and from the inner side of the fairings P/N 109-0324-25-303 and 109-0324-30-201 using a plastic scraper or putty knife. Clean thoroughly using Scotch-Brite and a clean, lint-free cloth moistened with cleaning solvent MIL-PRF-680 TY II.
22. Drill-out all the rivets that attach the forward LH cap, the forward LH protection P/N 109-0311-40-133 and the doubler P/N 109-0311-40-128 (under the forward LH protection P/N 109-0311-40-133). Break the sealant layer between the cap, the protection, the doubler and the structure using a thin blade or putty knife. Remove any trace of sealant from the structure using a plastic scraper or putty knife. Clean thoroughly using Scotch-Brite and a clean, lint-free cloth moistened with cleaning solvent MIL-PRF-680 TY II.
23. If installed, remove and retain for later reuse any additional shim that is installed between the rear part of the forward LH cap and the post structure.

NOTE

For A109E helicopters from S/N 11001 thru S/N 11600
included.

24. With reference to Figure 15, temporarily remove the internal doubler, then put the new forward LH cap P/N 109-0320-90-207 or -207A1 in the same position as the removed one. If necessary, remove some rivets on the post to allow an easy positioning.

NOTE

For A109E helicopters from S/N 11601 thru S/N 11674
included.

25. With reference to Figure 15, temporarily remove the internal doubler, then put the new forward LH cap P/N 109-0320-90-507 (in the same position as the removed one. If necessary, remove some rivets on the post to allow an easy positioning.
26. In order to fit the new forward cap to the existing structure, proceed as follow:
 - 26.1 With reference to Figure 15, trim the forward end to the necessary length.
 - 26.2 With reference to Figure 20, trim the two tabs at the aft end to the necessary length and shape.
 - 26.3 With reference to Figure 22, mark and cut the round notch for the torque tube.
 - 26.4 Mark and drill some holes to temporary secure the forward LH cap to the structure.

- 26.5 With reference to Figure 15, put in position the forward steel external protection and secure it in position in the forward part with Cleco fasteners. This allows the use the aft holes to complete the drilling of the new FWD LH cap.
- 26.6 With reference to Figure 14, drill all the remaining holes, except the holes in the upper external side for attachment of external fairings P/N 109-0324-25-303 and 109-0324-30-201.
- 26.7 Using the holes in the spar as a reference, drill the two \varnothing 6.25 mm holes for attachment of the support P/N 109-0011-18-1 of the torque tube.
27. With reference to Figure 16 thru Figure 18, find and mark the cutting line for the web P/N 109-0320-96-71 (or P/N 109-0320-96-505). Identify and remove all the rivets that attach the web to LH angle P/N 109-0320-96-73 (or P/N 109-0320-96-507), to forward and aft bulkhead P/N 109-0320-96, and to LH ribs P/N 109-0320-96-47 and P/N 109-0320-96-49. Using a putty knife, break the sealant/adhesive between the parts.
28. With reference to Figure 20, identify and remove the twelve additional rivets that attach the web P/N 109-0320-96-71 (or P/N 109-0320-96-505) to the forward and aft bulkheads. They must be removed to allow installation, at the end of the repair procedure, of the external butt-strap P/N 109-0952-67-123.
29. Remove the rivets that have been identified and marked in the previous Steps 27 and 28.

NOTE

Insert a thin steel sheet between the web and the forward and aft bulkheads to avoid damages while cutting the metal.

30. With reference to Figure 17, cut the web P/N 109-0320-96-71 (or P/N 109-0320-96-505).
31. With reference to Figure 17, identify and mark the cutting lines for angle P/N 109-0320-96-73 (or P/N 109-0320-96-507). The slant of cut shown in figure is indicative. Always make sure that cutting lines are equally spaced from the adjacent rivets. Identify all the rivets that attach the portion of angle to other structural elements of the post.
32. With reference to Figure 17, remove the rivets identified in the previous Step 31.
33. With reference to Figure 16 and Figure 19, remove the four rivets that attach the two nut-plates to the forward side of the post. Discard the two nut-plates.
34. With reference to Figure 16 and Figure 17, cut the angle P/N 109-0320-96-73 (or P/N 109-0320-96-507).
35. With reference to Figure 16 thru Figure 22, put the new angle P/N 109-0952-67-119, the new butt strap P/N 109-0952-67-121 and the web P/N 109-0952-67-125 in position on interior of the post. Mark the exact length of the angle P/N 109-0952-67-119, depending

on the cutting position of the existing angle.

36. With reference to Figure 23 and Figure 24, mark the exact length of the internal butt-strap P/N 109-0952-67-121.

NOTE

When marking the position of the rivet holes, make sure that the distance between the hole centre and the edge of the sheet is at least 2.5 times the diameter of the rivet.

37. Remove the new angle P/N 109-0952-67-119 and the new butt strap P/N 109-0952-67-121 and cut them to the exact length as defined in Steps 35 and 36. Reinstall the items in position and mark the position of the rivet holes.
38. Drill the holes to attach the new angle P/N 109-0952-67-119, the new butt strap P/N 109-0952-67-121 and the web P/N 109-0952-67-125 to the forward bulkhead P/N 109-0320-96. Attach the parts in position with Cleco fasteners.
39. Put the web P/N 109-0952-67-125 in position on the post. Drill the holes to secure the new internal butt strap P/N 109-0952-67-121.
40. With reference to Figure 20, put the external butt-strap P/N 109-0952-67-123 in position. If necessary, adapt the shape to the profile of the post to allow the correct installation. Mark and drill the attachment holes.
41. With reference to Figure 23 and Figure 24, cut the oversize material from the external butt-strap.
42. Remove the paint from the existing web P/N 109-0320-96-71 (or P/N 109-0320-96-505) and from the new web P/N 109-0952-67-125 in the area of installation of the external butt-strap P/N 109-0952-67-123.

NOTE

For accessibility reason, it is allowed to install rivets P/N A879A05L150 on opposite direction (rivet from outside to inside STA1815 honeycomb).

43. With reference to Figure 19 thru Figure 22, put in position the new angle P/N 109-0952-67-119, the new butt strap P/N 109-0952-67-121 and the web P/N 109-0952-67-125. Bond the internal butt-strap P/N 109-0952-67-121 with adhesive EA9309.3NA. Starting from the forward side of the post, install the rivets.
44. With reference to Figure 19 thru Figure 22, bond the external butt-strap P/N 109-0952-67-123 to the post using adhesive EA9309.3NA and rivets. Seal edges of external butt-strap P/N 109-0952-67-123 using PROSEAL 890B2.
45. With reference to Figure 19, reinstall and bond with adhesive EA9309.3NA all the shims that were installed under the lower end of forward LH bulkhead P/N 109-0320-96.

NOTE

Make sure that the rivets in the zone of installation of the torque tube support P/N 109-0011-18-1 have the countersunk head on both sides. Make sure that the head does not protrude over the surface. Flush the heads if necessary.

NOTE

For A109E helicopters from S/N 11001 thru S/N 11600 included.

46. With reference to Figure 14 and Figure 15, put the forward cap P/N 109-0320-90-207 or -207A1 in position and bond with PROSEAL 890B2. Install the forward cap using the same type of rivets as previously removed or the alternate rivets.

NOTE

For A109E helicopters from S/N 11601 thru S/N 11674 included.

47. With reference to Figure 14 and Figure 15, put the forward cap P/N 109-0320-90-507 in position and bond with PROSEAL 890B2. Install the forward cap using the same type of rivets as previously removed or the alternate rivets
48. Seal the edges of the forward LH cap using sealant PROSEAL 890B2.
49. Seal the edges of the external butt-strap P/N 109-0952-67-123 and of the web P/N 109-0952-67-125 using sealant PROSEAL 890B2.
50. With reference to Figure 19, install the two nutplates MS21071L08 and MS21069L08 in position. Use the collective lever guard assy P/N 109-0700-25-127 (if the helicopter is equipped with dual control) or the fairing P/N 109-0011-28-1 (if the helicopter is not equipped with dual control) to mark the position of the nutplates.
51. Temporarily put the LH post lower fairing P/N 109-0324-30-201 and the LH lower fairing P/N 109-0324-25-303 in position and drill the rivet holes in the upper part of the forward LH cap P/N 109-0320-90-207 or -207A1 or -507.
52. Touch-up the exposed areas of the repaired zones with primer and paint to restore the original aspect.
53. With reference to Figure 13, bond with PROSEAL 890B2 then attach with rivets the LH lower fairing P/N 109-0324-25-303. Make sure that that the drain holes in the fairing are not plugged by the sealant.
54. With reference to Figure 13, bond with PROSEAL 890B2 then attach with rivets the LH post lower fairing P/N 109-0324-30-201. Make sure that that the drain holes in the fairing are not plugged by the sealant.

55. In accordance with MM Paragraphs 07-30-1 or 07-30-2, lay down the helicopter.
56. Reinstall the cockpit/passenger doors caution system switch on the LH post centre fairing P/N 109-0324-29-101 using the related screws. Put the shims (if any) in their original position.
57. With reference to Figure 13, reinstall the LH post centre fairing P/N 109-0324-29-101 using the related attaching screws.
58. If originally installed, reinstall the sill-liner or apply the anti-slip paint on the upper side of the fairings P/N 109-0324-25-303 and 109-0324-30-201.
59. Reinstall the cockpit and passenger doors seals.
60. In accordance with MM Paragraph 21-21-1, reinstall the air conditioning duct located inside the door lower sill.
61. Reinstall the collective stick connector removed at Step 13.
62. In accordance with MM Paragraphs 67-00-12 and 67-11-9, reinstall the collective control torque tube.
63. If removed (Ref. Step 7), in accordance with MM Paragraphs 67-00-12 and 67-11-9, reinstall the co-pilot collective control lever.
64. With reference to Figure 11 and Figure 12, reinstall the collective control rod assy P/N 109-0032-04-41 and the tail rotor control rod assy P/N 109-0032-02-25 as follows:

CAUTION

Apply the maximum care to prevent any damage to the control rod caused by rubbing with other parts of the helicopter.

- 64.1 Put the collective control rod assy in position on interior of the left cabin post by inserting it from the top. Observe the correct sense of installation, as identified in previous Step 2.8.
- 64.2 Attach the upper end of the collective control rod assy to the lever using the bolt AN174-12, the washer A160A0432K (under bolt head and with countersunk side toward the bolt head), the washer AN960-PD416 (under the nut) and the nut MS17825-4. Torque the nut to 3.4 thru 4.5 Nm and install a new cotter pin MS24665-153.
- 64.3 Attach the lower end of the collective control rod assy to the lever using the bolt AN174-12, the washer A160A0432K (under bolt head and with countersunk side toward the bolt head), the washer AN960-PD416 (under the nut) and the nut MS17825-4. If necessary, move slightly the collective control lever as necessary to allow the insertion of the bolt. Torque the nut to 3.4 thru 4.5 Nm and install a new cotter pin MS24665-153.

CAUTION

Apply the maximum care to prevent any damage to the control rod caused by rubbing with other parts of the helicopter.

- 64.4 Put the tail rotor control rod assy in position on interior of the left cabin post by inserting it from the top. Observe the correct sense of installation, as identified in previous Step 2.8.
- 64.5 Attach the upper end of the tail rotor control rod assy to the lever using the bolt AN174-12, the washer AN960-PD416 under the nut and the nut MS17825-4. Torque the nut to 3.4 thru 4.5 Nm and install a new cotter pin MS24665-151.
- 64.6 Attach the lower end of the tail rotor control rod assy to the lever using the bolt AN174-12, the washer AN960-PD416 under the nut and the nut MS17825-4. If necessary, move slightly the pedals as necessary to allow the insertion of the bolt. Torque the nut to 3.4 thru 4.5 Nm and install a new cotter pin MS24665-151.
- 64.7 Remove the masking tape that has been put on the rods to identify the direction of installation (ref. Step 2.8).
- 64.8 Perform a duplicate inspection of installation of the control rods. The duplicate inspection must include, but is not limited to, correct assembly, security, correct application of cotter pins, thread engagement and protrusion, and a functional check for complete range, freedom of movement and operation in correct sense.
65. For the collective installation affected by collective control rod assy P/N 109-0032-02-41 and Torque Tube removal and re-installation, perform the following step of MM Paragraph 67-00-25 (ref. Figures 3 thru 10):
- Put the minimum collective lever positioning Tool (LSE 198) in its position on the interseat console;
 - Move the pilot collective stick down and put the lower side of the stick against the pin of the tool. Being collective control rod assy P/N 109-0032-02-41 mechanically connected to the lower and upper lever, as per Step 64.2 and 64.3, also the mixing unit will be moved FWD. Pay attention to provide hydraulic power supply at 1500 PSI before moving the stick;
 - Check that the minimum Collective Stop is engaged as per Step X. If not, apply the following Step from Step A up to Step H;
 - Remove the Tool (minimum collective lever) from the cockpit;
 - Loosen the adjustable friction;
 - Move the collective stick three or four times. Make sure that the collective controls are free to operate without friction against the structure.
66. Perform an operational test of the collective control system, and of the tail rotor control

system, to make sure that the control linkages move freely.

67. Reinstall all the access panels you have removed to perform the repair.

NOTE

For A109E helicopters from S/N 11001 thru S/N 11600 included.

68. Panel P/N 109-0320-90-7, removed at Step 10, can be reused after removing thoroughly any trace of sealant using a plastic scraper and a cloth moistened with solvent MIL-PRF-680 TY II.

NOTE

For A109E helicopters from S/N 11601 thru S/N 11674 included.

69. Panel P/N 109-0320-90-505, removed at Step 10, can be reused after removing thoroughly any trace of sealant using a plastic scraper and a cloth moistened with solvent MIL-PRF-680 TY II.

70. Reinstall the collective lever guard assy P/N 109-0700-25-127 (if the helicopter is equipped with dual control) or the fairing P/N 109-0011-28-1 (if the helicopter is not equipped with dual control).

71. Reinstall the support panels located under the pilot and co-pilot seat. Reinstall also the centre panel located between the seats and any control located on it (e.g. friction knob, cargo hook release handle).

72. Reinstall the access door P/N 109-0322-10-13 on the upper part of the fuselage, over the door post, and move the platform away from helicopter.

73. Reinstall the access panel P/N 109-0320-90-63.

74. In accordance with MM Paragraph 21-21-1, reinstall the air distribution duct P/N 109-0710-32-105 on the door post.

75. With reference to the pertinent MM Paragraph, reinstall all the items of equipment/furnishing that were removed to gain access to work area.

76. If originally installed, in accordance with MM Paragraph 25-21-12, reinstall the forward passenger seat.

77. In accordance with MM Paragraph 25-11-9, reinstall the pilot and co-pilot seat.

78. If originally installed, in accordance with MM Paragraphs 25-81-7 and 25-81-9, reinstall the cockpit and passenger compartment soundproofing panels or the moquette lining.

79. In accordance with MM Paragraph 52-11-9, reinstall the pilot and co-pilot doors and close the passenger compartment doors.

80. In accordance with MM Paragraph 52-71-6, perform an operational test of the cockpit/passenger doors caution system.

81. Return the helicopter to a ready to flight condition and record for compliance with Part II of this Service Bulletin on the helicopter logbook.
82. Gain access to My Communications section on Leonardo WebPortal and compile the "Service Bulletin Application Communication".

As an alternative, send the attached compliance form to the following mail box:

engineering.support.lhd@leonardo.com

and (for North, Central and South America) also to:

AWPC.Engineering.Support@leonardocompany.us

PART III

NOTE

If undamaged, parts P/N 109-0320-96-72 (or P/N 109-0320-96-506) and 109-0320-96-74 (or P/N 109-0320-96-508) may not be cut and reused in their respective position.

1. In accordance with MM Paragraph 00-20-1, prepare the helicopter on ground for a safe maintenance. Disconnect the battery, all electrical power sources and/or the external power supply.
2. With reference to Figure 25 and Figure 26, remove the lateral cyclic control rod assy P/N 109-0032-19-101 and the longitudinal cyclic control rod assy P/N 109-0032-07-01 as follows:
 - 2.1 In accordance with MM Paragraph 25-11-9, remove the pilot seat.
 - 2.2 If installed, in accordance with MM Paragraph 25-21-12, remove the forward passenger seat.
 - 2.3 In accordance with the pertinent MM Paragraph, remove any other item of equipment/furnishing that might prevent the access to the work area.
 - 2.4 If installed, in accordance with MM Paragraphs 25-81-7 and 25-81-9, remove the cockpit and passenger compartment soundproofing panels or the moquette lining that might prevent the access to the inspection zone.
 - 2.5 In accordance with MM Paragraph 21-21-1, remove the air distribution duct P/N 109-0710-32-105 from the left door post.
 - 2.6 Remove the access panel 109-0320-90-206.
 - 2.7 Remove the access door P/N 109-0322-10-14 on the upper part of the fuselage, over the door post.
 - 2.8 Using masking tape, identify the position and the sense of installation of each control rod assy.
 - 2.9 With reference to Figure 25, on the lower end of the lateral cyclic control rod assy, remove the cotter pin, the nut, the bolt and the washers that attach the lower end of the control rod assy to the lever. Discard the cotter pin. If necessary, move slightly the cyclic control stick to allow an easy removal of the bolt.

CAUTION

During the hardware removing, keep the rod assy to prevent it from falling.

- 2.10 With reference to Figure 25, on the upper end of the lateral cyclic control rod assy, remove the cotter pin, the nut, the bolt and the washers that attach the upper end of the control rod assy to the lever. Discard the cotter pin.

NOTE

Do not change the length of the lateral cyclic control rod assy.

CAUTION

Apply the maximum care to prevent any damage to the control rod caused by rubbing with other parts of the helicopter.

- 2.11 Withdraw the lateral cyclic control rod assy toward the upper side of helicopter.
- 2.12 With reference to Figure 26, on the lower end of the longitudinal cyclic control rod assy, remove the cotter pin, the nut, the bolt and the washers that attach the lower end of the control rod assy to the lever. Discard the cotter pin.

CAUTION

During the hardware removing, keep the rod assy to prevent it from falling.

- 2.13 With reference to Figure 26, on the upper end of the longitudinal cyclic control rod assy, remove the cotter pin, the nut, the bolt and the washers that attach the upper end of the control rod assy to the lever. Discard the cotter pin.

NOTE

Do not change the length of the longitudinal cyclic control rod.

CAUTION

Apply the maximum care to prevent any damage to the control rod caused by rubbing with other parts of the helicopter.

- 2.14 Withdraw the longitudinal cyclic control rod toward the upper side of helicopter.
3. In accordance with MM Paragraph 52-11-9, remove the pilot and co-pilot door. Open both the passenger compartment doors and lock them in opened position.
4. Remove the pilot door seal assy P/N 109-0360-88-110 and the passenger door seal assy P/N 109-0360-86-110. Remove any trace of adhesive and rubber from installation areas using a plastic scraper and a soft cloth moistened with solvent.
5. In accordance with MM Paragraph 25-11-9, remove the co-pilot seat.
6. Remove the support panels located under the pilot and co-pilot seat. Remove also the

centre panel located between the seats and any control located on it (e.g. friction knob, cargo hook release handle).

7. Remove and retain for later re-use all the access panels located on the door sill.
8. With reference to Figure 2, remove the access panels P/N 109-0320-96-522 and P/N 109-0320-96-310 located on the post. Retain all the fixing hardware for later reuse.
9. Remove the air conditioning duct located inside the door lower sill. Cap thoroughly the open ends of the adjacent ducts to prevent any unwanted entry of foreign materials in the air conditioning system.
10. In accordance with MM Paragraphs 67-00-12 and 67-12-1, remove and retain for later reuse the following components of the flight control system:
 - Lateral cyclic control rod P/N 109-0032-01-1;
 - Longitudinal cyclic control rod P/N 109-0032-03-1;
 - Lateral cyclic lever P/N 109-0020-17-1;
 - Lateral cyclic control rod P/N 109-0032-02-1.
11. With reference to figure 13, remove the RH post centre fairing P/N 109-0324-29-102 by removing the related attaching screws.
12. Remove the cockpit/passenger doors caution system switch from the fairing removed at previous Step 11 by removing the two attaching screws. Leave the switch attached to the wire. Take note of quantity of shims below the switch in order to allow the reinstallation in their original position.
13. If applied, remove any sill-liner or anti-slip paint from the upper side of the fairings P/N 109-0324-25-304 and 109-0324-30-202.
14. In accordance with MM Paragraphs 07-30-1 or 07-30-2, raise the helicopter using the lifting device P/N 109-3900-01-1 connected to a suitable crane/hoist and put the cable in tension.
15. With reference to Figure 27, remove the RH lower fairing P/N 109-0324-25-304 by drilling-out the attaching rivets. Break the sealant layer between the fairing and the structure using a thin blade or putty knife.
16. With reference to Figure 27, remove the RH post lower fairing P/N 109-0324-30-202 by drilling-out the attaching rivets. Break the sealant layer between the fairing and the structure using a thin blade or putty knife.
17. Remove any trace of sealant from the structure and from the inner side of the fairings P/N 109-0324-25-304 and 109-0324-30-202 using a plastic scraper or putty knife. Clean thoroughly using Scotch-Brite and a clean, lint-free cloth moistened with cleaning solvent MIL-PRF-680 TY II.
18. Drill-out all the rivets that attach the forward RH cap, the forward RH protection P/N

- 109-0311-40-134 and the doubler P/N 109-0311-40-128 (under the forward RH protection P/N 109-0311-40-134). Break the sealant layer between the cap, the protection, the doubler and the structure using a thin blade or putty knife. Remove any trace of sealant from the structure using a plastic scraper or putty knife. Clean thoroughly using Scotch-Brite and a clean, lint-free cloth moistened with cleaning solvent MIL-PRF-680 TY II.
19. If installed, remove and retain for later reuse any additional shim that is installed between the rear part of the forward RH cap and the post structure.
 20. With reference to Figure 28, temporarily remove the internal doubler, then put the new forward RH cap P/N 109-0320-90-208 or -208A1 in the same position as the removed one. If necessary, remove some rivets on the post to allow an easy positioning.
 21. In order to fit the new forward cap to the existing structure, proceed as follow:
 - 21.1 With reference to Figure 28, trim the forward end to the necessary length.
 - 21.2 With reference to Figure 33 and Figure 34, trim the two tabs at the aft end to the necessary length and shape.
 - 21.3 Mark and drill some holes to temporary secure the forward RH cap to the structure.
 - 21.4 With reference to Figure 28, put in position the forward steel external protection and secure it in position in the forward part with Cleco fasteners. This allows the use the aft holes to complete the drilling of the new FWD RH cap.
 - 21.5 With reference to Figure 28, drill all the remaining holes, except the holes in the upper external side for attachment of external fairings P/N 109-0324-25-304 and 109-0324-30-202.
 22. With reference to Figure 29 thru Figure 31, find and mark the cutting line for the web P/N 109-0320-96-72 (or P/N 109-0320-96-506). Identify and remove all the rivets that attach the web to RH angle P/N 109-0320-96-74 (or P/N 109-0320-96-508), to forward and aft bulkhead P/N 109-0320-96, and to RH ribs P/N 109-0320-96-48 and P/N 109-0320-96-50. Using a putty knife, break the sealant/adhesive between the parts.
 23. With reference to Figure 33 and Figure 34, identify and remove the twelve additional rivets that attach the web P/N 109-0320-96-72 (or P/N 109-0320-96-506) to the forward and aft bulkheads. They must be removed to allow installation, at the end of the repair procedure, of the external butt-strap P/N 109-0952-67-115.
 24. Remove the rivets that have been identified and marked in the previous Steps 22 and 23.

NOTE

Insert a thin steel sheet between the web and the forward and aft bulkheads to avoid damages while cutting the metal.

25. With reference to Figure 30, cut the web P/N 109-0320-96-72 (or P/N 109-0320-96-506).

26. With reference to Figure 30, identify and mark the cutting lines for angle P/N 109-0320-96-74 (or P/N 109-0320-96-508). The slant of cut shown in figure is indicative. Always make sure that cutting lines are equally spaced from the adjacent rivets. Identify all the rivets that attach the portion of angle to other structural elements of the post.
27. With reference to Figure 30, remove the rivets identified in the previous Step 26.
28. With reference to Figure 29 and Figure 30, cut the angle P/N 109-0320-96-74 (or P/N 109-0320-96-508).
29. With reference to Figure 29 thru Figure 34, put the new angle P/N 109-0952-67-111, the new internal butt strap P/N 109-0952-67-113 and the web P/N 109-0952-67-109 in position on interior of the post. Mark the exact length of the angle P/N 109-0952-67-111, depending on the cutting position of the existing angle.
30. With reference to Figure 35 and Figure 36, mark the exact length of the internal butt-strap P/N 109-0952-67-113.

NOTE

When marking the position of the rivet holes, make sure that the distance between the hole centre and the edge of the sheet is at least 2.5 times the diameter of the rivet.

31. Remove the new angle P/N 109-0952-67-111 and the new butt strap P/N 109-0952-67-113 and cut them to the exact length as defined in Steps 29 and 30 above. Reinstall the items in position and mark the position of the rivet holes.
32. Drill the holes to attach the new angle P/N 109-0952-67-111, the new butt strap P/N 109-0952-67-113 and the web P/N 109-0952-67-109 to the forward bulkhead P/N 109-0320-96. Attach the parts in position with Cleco fasteners.
33. Put the web P/N 109-0952-67-109 in position on the post. Drill the holes to secure the new butt strap P/N 109-0952-67-113.
34. With reference to Figure 33 and Figure 34, put the external butt-strap P/N 109-0952-67-115 in position. If necessary, adapt the shape to the profile of the post to allow the correct installation. Mark and drill the attachment holes.
35. With reference to Figure 35 and Figure 36, cut the oversize material from the external butt-strap.
36. Remove the paint from the existing web P/N 109-0320-96-72 (or P/N 109-0320-96-506) and from the new web P/N 109-0952-67-109 in the area of installation of the external butt-strap P/N 109-0952-67-115.

NOTE

For accessibility reason, it is allowed to install rivets P/N A879A05L150 on opposite direction (rivet from outside to inside STA1815 honeycomb).

37. With reference to Figure 32 thru Figure 34, put in position the new angle P/N 109-0952-67-111, the new butt strap P/N 109-0952-67-113 and the web P/N 109-0952-67-109. Bond the internal butt-strap P/N 109-0952-67-113 with EA9309.3NA. Starting from the forward side of the post, install the rivets.
38. With reference to Figure 32 thru Figure 34, bond the external butt-strap P/N 109-0952-67-115 to the post using EA9309.3NA adhesive and rivets. Seal edges of external butt-strap P/N 109-0952-67-115 using PROSEAL 890B2.
39. With reference to Figure 32, reinstall and bond with EA9309.3NA all the shims that were installed under the lower end of forward RH bulkhead P/N 109-0320-96.

NOTE

Make sure that the rivets in the zone of installation of the torque tube support P/N 109-0011-18-1 have the countersunk head on both sides. Make sure that the head does not protrude over the surface. Flush the heads if necessary.

40. With reference to Figure 28, put the forward cap P/N 109-0320-90-208 or -208A1 in position and bond with PROSEAL 890B2. Install the forward cap using the same type of rivets as previously removed or the alternate rivets.
41. Seal the edges of the forward RH cap using sealant PROSEAL 890B2.
42. Seal the edges of the external butt-strap P/N 109-0952-67-115 and of the web P/N 109-0952-67-109 using sealant PROSEAL 890B2.
43. Temporarily put the RH post lower fairing P/N 109-0324-30-202 and the RH lower fairing P/N 109-0324-25-304 in position and drill the rivet holes in the upper part of the forward RH cap P/N 109-0320-90-208 or -208A1.
44. Touch-up the exposed areas of the repaired zones with primer and paint to restore the original aspect.
45. With reference to Figure 27, bond with PROSEAL 890B2 then attach with rivets the RH lower fairing P/N 109-0324-25-304. Make sure that that the drain holes in the fairing are not plugged by the sealant.
46. With reference to Figure 27, bond with PROSEAL 890B2 then attach with rivets the RH post lower fairing P/N 109-0324-30-202. Make sure that that the drain holes in the fairing are not plugged by the sealant.

47. In accordance with MM Paragraphs 07-30-1 or 07-30-2, lay down the helicopter.
48. Reinstall the cockpit/passenger doors caution system switch on the RH post centre fairing P/N 109-0324-29-102 using the related screws. Put the shims (if any) in their original position.
49. With reference to Figure 27, reinstall the LH post centre fairing P/N 109-0324-29-102 using the related attaching screws.
50. If originally installed, reinstall the sill-liner or apply the anti-slip paint on the upper side of the fairings P/N 109-0324-25-304 and 109-0324-30-202.
51. Reinstall the cockpit and passenger doors seals.
52. In accordance with MM Paragraphs 67-00-12 and 67-12-1, reinstall the following components of the flight control system:
 - Lateral cyclic control rod P/N 109-0032-01-1;
 - Longitudinal cyclic control rod P/N 109-0032-03-1;
 - Lateral cyclic lever P/N 109-0020-17-1;
 - Lateral cyclic control rod P/N 109-0032-02-1.
53. In accordance with MM Paragraph 21-21-1, reinstall the air conditioning duct located inside the door lower sill.
54. With reference to Figure 25 and Figure 26, reinstall the lateral cyclic control rod assy and the longitudinal cyclic control rod assy P/N 109-0032-07-01 as follows:

CAUTION

Apply the maximum care to prevent any damage to the control rod caused by rubbing with other parts of the helicopter.

- 54.1 Put the longitudinal control rod assy in position on interior of the right cabin post by inserting it from the top. Observe the correct sense and position of installation, as identified in previous Step 2.8.
- 54.2 With reference to Figure 26, attach the upper end of the longitudinal control rod to the lever using the bolt AN174-12, one washer AN960-PD416 (under the bolt head), one washer AN960-PD416 under the nut, and the nut MS17825-4. Torque the nut to 3.4 thru 4.5 Nm and install a new cotter pin MS24665-153. If necessary, install one additional washer AN960-PD416 under the nut to obtain the correct engagement of the nut.

- 54.3 With reference to Figure 26, attach the lower end of the longitudinal control rod to the lever using the bolt AN174-12, one washer AN960-PD416 (under the bolt head), one washer AN960-PD416 under the nut, and the nut MS17825-4. If required, move slightly cyclic control stick as necessary to allow the insertion of the bolt. Torque the nut to 3.4 thru 4.5 Nm and install a new cotter pin MS24665-153. If necessary, install one additional washer AN960-PD416 under the nut to obtain the correct engagement of the nut.

CAUTION

Apply the maximum care to prevent any damage to the control rod caused by rubbing with other parts of the helicopter.

- 54.4 Put the lateral control rod assy in position on interior of the right cabin post by inserting it from the top. Observe the correct sense and position of installation, as identified in previous Step 2.8.
- 54.5 With reference to Figure 25, attach the upper end of the lateral control rod to the lever using the bolt AN174-12, one washer AN960-PD416 (under the bolt head), one washer AN960-PD416 under the nut, and the nut MS17825-4. Torque the nut to 3.4 thru 4.5 Nm and install a new cotter pin MS24665-153. If necessary, install one additional washer AN960-PD416 under the nut to obtain the correct engagement of the nut.
- 54.6 With reference to Figure 25, attach the lower end of the lateral control rod) to the lever using the bolt AN174-12, one washer AN960-PD416 (under the bolt head), one washer AN960-PD416 under the nut, and the nut MS17825-4. If required, move slightly cyclic control stick as necessary to allow the insertion of the bolt. Torque the nut to 3.4 thru 4.5 Nm and install a new cotter pin MS24665-153. If necessary, install one additional washer AN960-PD416 under the nut to obtain the correct engagement of the nut.
- 54.7 Remove the masking tape that has been put on the rods to identify the direction of installation (ref. Step 2.8).
- 54.8 Perform a duplicate inspection of installation of the control rods. The duplicate inspection must include, but is not limited to, correct assembly, security, correct application of cotter pins, thread engagement and protrusion, and a functional check for complete range, freedom of movement and operation in correct sense.
55. To check that the Fixed Flight Component have been properly re-installed, get access to the cyclic control stick on the left side of the cockpit, and with hydraulic power supply at 1500 PSI perform the following Step of MM Paragraph 67-00-26, (ref. Figures 3 thru 10):

- Disengage the spring P/N 109-0020-36 from the bracket;
 - Fully loosen the friction control;
 - Step B;
 - Step C. If rigging pins do not fit, apply MM Paragraph 67-00-26;
 - Engage the spring P/N 109-0020-36 on bracket;
 - Step H;
 - Do the adjustment of the fixed frictions of the cyclic control system.
56. Perform an operational test of the cyclic control system to make sure that the control linkages move freely.
57. Reinstall all the access panels you have removed to perform the repair.
58. Panel P/N 109-0320-90-8, removed at Step 7, can be reused after removing thoroughly any trace of sealant using a plastic scraper and a cloth moistened with solvent MIL-PRF-680 TY II.
59. Reinstall the support panels located under the pilot and co-pilot seat. Reinstall also the centre panel located between the seats and any control located on it (e.g. friction knob, cargo hook release handle).
60. Reinstall the access door P/N 109-0322-10-14 on the upper part of the fuselage, over the door post, and move the platform away from helicopter.
61. Reinstall the access panel P/N 109-0320-90-206.
62. In accordance with MM Paragraph 21-21-1, reinstall the air distribution duct P/N 109-0710-32-106 on the door post.
63. With reference to the pertinent MM Paragraph, reinstall all the items of equipment/furnishing that were removed to gain access to work area.
64. If originally installed, in accordance with MM Paragraph 25-21-12, reinstall the forward passenger seat.
65. In accordance with MM Paragraph 25-11-9, reinstall the pilot and co-pilot seat.
66. If originally installed, in accordance with MM Paragraphs 25-81-7 and 25-81-9, reinstall the cockpit and passenger compartment soundproofing panels or the moquette lining.
67. In accordance with MM Paragraph 52-11-9, reinstall the pilot and co-pilot doors and close the passenger compartment doors.
68. In accordance with MM Paragraph 52-71-6, perform an operational test of the cockpit/passenger doors caution system.
69. Return the helicopter to a ready to flight condition and record for compliance with Part III of this Service Bulletin on the helicopter logbook.
70. Gain access to My Communications section on Leonardo WebPortal and compile the "Service Bulletin Application Communication".

As an alternative, send the attached compliance form to the following mail box:

engineering.support.lhd@leonardo.com

and (for North, Central and South America) also to:

AWPC.Engineering.Support@leonardocompany.us

PART IV

NOTE

If the helicopter's LH post has been repaired in accordance with Part II (LH side) of this Service Bulletin, or in accordance with repair drawing P/N 109-0952-67-117 (LH side), the helicopter could install web with P/N 109-0320-96-71 (or P/N 109-0320-96-505 or P/N 109-0952-67-125), and LH angle with P/N 109-0320-96-73 (or P/N 109-0320-96-507 or P/N 109-0952-67-119).

NOTE

If undamaged, parts P/N 109-0320-96-71 (or P/N 109-0320-96-505) and 109-0320-96-73 (or P/N 109-0320-96-507) may not be cut and reused in their respective position.

1. In accordance with MM Paragraph 00-20-1, prepare the helicopter on ground for a safe maintenance. Disconnect the battery, all electrical power sources and/or the external power supply.
2. With reference to Figure 11 and Figure 12, remove the collective control rod assy P/N 109-0032-02-41 and the tail rotor control rod assy P/N 109-0032-02-25 as follows:
 - 2.1 In accordance with MM Paragraph 25-11-9, remove the co-pilot seat.
 - 2.2 If installed, in accordance with MM Paragraph 25-21-12, remove the forward passenger seat.
 - 2.3 In accordance with the pertinent MM Paragraph, remove any other item of equipment/furnishing that might prevent the access to the work area.
 - 2.4 If installed, in accordance with MM Paragraphs 25-81-7 and 25-81-9, remove the cockpit and passenger compartment soundproofing panels or the moquette lining that might prevent the access to the inspection zone.
 - 2.5 In accordance with MM Paragraph 21-21-1, remove the air distribution duct P/N 109-0710-32-105 from the left door post.
 - 2.6 Remove the access panel P/N 109-0320-90-63.
 - 2.7 Remove the access door P/N 109-0322-10-13 on the upper part of the fuselage, over the door post.
 - 2.8 Using masking tape, identify the position and the sense of installation of each control rod assy.

- 2.9 With reference to Figure 11, on the lower end of the collective control rod assy, remove the cotter pin, the nut, the bolt and the washers that attach the lower end of the control rod assy to the lever. Discard the cotter pin. If necessary, move slightly the collective control lever and/or the pedals to allow an easy removal of the bolt.

CAUTION

During the hardware removing, keep the rod assy to prevent it from falling.

- 2.10 With reference to Figure 11, on the upper end of the collective control rod assy, remove the cotter pin, the nut, the bolt and the washers that attach the upper end of the control rod assy to the lever. Discard the cotter pin.

NOTE

Do not change the length of the collective control rod assy.

CAUTION

Apply the maximum care to prevent any damage to the control rod caused by rubbing with other parts of the helicopter.

- 2.11 Withdraw the collective control rod assy from the upper side of helicopter.
- 2.12 With reference to Figure 12, on the lower end of the tail rotor control rod assy, remove the cotter pin, the nut, the bolt and the washer that attach the lower end of the control rod assy to the lever. Discard the cotter pin.

CAUTION

During the hardware removing, keep the rod assy to prevent it from falling.

- 2.13 With reference to Figure 12, on the upper end of the tail rotor control rod assy, remove, the nut, the bolt and the washer that attach the lower end of the control rod assy to the lever. Discard the cotter pin.

NOTE

Do not change the length of the tail rotor control rod assy.

CAUTION

Apply the maximum care to prevent any damage to the control rod caused by rubbing with other parts of the helicopter.

- 2.14 Withdraw the tail rotor control rod assy from the upper side of helicopter.
3. In accordance with MM Paragraph 52-11-9, remove the pilot and co-pilot door. Open both the passenger compartment doors and lock them in opened position.
 4. Remove the co-pilot door seal assy P/N 109-0360-88-109 and the passenger door seal assy P/N 109-0360-86-109. Remove any trace of adhesive and rubber from installation areas using a plastic scraper and a soft cloth moistened with solvent.
 5. In accordance with MM Paragraph 25-11-9, remove the pilot seat.
 6. Remove the support panels located under the pilot and co-pilot seat. Remove also the centre panel located between the seats and any control located on it (e.g. friction knob, cargo hook release handle).
 7. If installed, in accordance with MM Paragraphs 67-00-12 and 67-11-9, remove the co-pilot collective control lever.
 8. Set the collective control in fully-up position then lock the collective torque tube using the friction.
 9. Remove the collective lever guard assy P/N 109-0700-25-127 (if the helicopter is equipped with dual control) or the fairing P/N 109-0011-28-1 (if the helicopter is not equipped with dual control).
 10. Remove and retain for later re-use all the access panels located on the door sill.
 11. With reference to Figure 2, remove the access panels P/N 109-0320-96-521 and P/N 109-0320-96-309 located on the post. Retain all the fixing hardware for later reuse.
 12. Remove the air conditioning duct located inside the door lower sill. Cap thoroughly the open ends of the adjacent ducts to prevent any unwanted entry of foreign materials in the air conditioning system.
 13. Remove the collective stick connector located on the right side of the co-pilot seat support structure. Wrap the connector using a plastic sheet and stow it in a safe place.
 14. In accordance with MM Paragraphs 67-00-12 and 67-11-9, remove the collective control torque tube. To make easier the reinstallation of the torque tube at the end of the repair, it is advisable to mark the position of the following components on the torque tube using a thin felt-tip pen:
 - LVDT sensors (collective transducers);
 - Engine-out switch (if installed in accordance with SB 109EP-081);
 - Collective friction;
 - Support on the LH side of the torque tube.
 15. With reference to Figure 13, remove the LH post centre fairing P/N 109-0324-29-101 by removing the related attaching screws.
 16. Remove the cockpit/passenger doors caution system switch from the fairing removed at

- previous Step 15 by removing the two attaching screws. Leave the switch attached to the wire. Take note of quantity of shims below the switch in order to allow the reinstallation in their original position.
17. If applied, remove any sill-liner or anti-slip paint from the upper side of the fairings P/N 109-0324-25-303 and 109-0324-30-201.
 18. In accordance with MM Paragraphs 07-30-1 or 07-30-2, raise the helicopter using the lifting device P/N 109-3900-01-1 connected to a suitable crane/hoist and put the cable in tension.
 19. With reference to Figure 13, remove the LH lower fairing P/N 109-0324-25-303 by drilling-out the attaching rivets. Break the sealant layer between the fairing and the structure using a thin blade or putty knife.
 20. With reference to Figure 13, remove the LH post lower fairing P/N 109-0324-30-201 by drilling-out the attaching rivets. Break the sealant layer between the fairing and the structure using a thin blade or putty knife.
 21. Remove any trace of sealant from the structure and from the inner side of the fairings P/N 109-0324-25-303 and 109-0324-30-201 using a plastic scraper or putty knife. Clean thoroughly using Scotch-Brite and a clean, lint-free cloth moistened with cleaning solvent MIL-PRF-680 TY II.
 22. Drill-out all the rivets that attach the forward LH cap, the forward LH protection P/N 109-0311-40-133 and the doubler P/N 109-0311-40-128 (under the forward LH protection P/N 109-0311-40-133). Break the sealant layer between the cap, the protection, the doubler and the structure using a thin blade or putty knife. Remove any trace of sealant from the structure using a plastic scraper or putty knife. Clean thoroughly using Scotch-Brite and a clean, lint-free cloth moistened with cleaning solvent MIL-PRF-680 TY II.
 23. If installed, remove and retain for later reuse any additional shim that is installed between the rear part of the forward LH cap and the post structure.
 24. With reference to Figure 38, remove the forward LH cap P/N 109-0320-90-207 or -507. Discard only if the part is damaged.
 25. With reference to Figure 38, remove the left cap P/N 109-0320-90-53.
 26. With reference to Figure 40 View E-E, temporarily remove the FWD bulkhead LH P/N 109-0320-96-311, the LH core P/N 109-0320-90-117 and the LH angle P/N 109-0320-90-41.
 27. With reference to Figure 41, remove the filler P/N 109-0320-90-175.
 28. With reference to Figure 38, install the LH angle P/N 109G5307P39-113 by means of adhesive EA9309.3NA.
 29. With reference to Figure 41, install the stiffener machined LH P/N 109G5330A25-101 by means of adhesive EA9309.3NA.

30. With reference to Figure 37 thru Figure 41, install the following parts by means of the indicated rivets:
- the left cap P/N 109G5307P39-115;
 - the doubler P/N 109G5307P39-117;
 - the previously removed FWD bulkhead LH P/N 109-0320-96-311,
 - the previously removed LH core P/N 109-0320-90-117;
 - the previously removed LH angle P/N 109-0320-90-41.
31. With reference to Figure 42 thru Figure 47, find and mark the cutting line for the web P/N 109-0320-96-71 (or P/N 109-0320-96-505). Identify and remove all the rivets that attach the web to LH angle P/N 109-0320-96-73 (or P/N 109-0320-96-507), to forward and aft bulkhead P/N 109-0320-96, and to LH ribs P/N 109-0320-96-47 and P/N 109-0320-96-49. Using a putty knife, break the sealant/adhesive between the parts.
32. With reference to Figure 43, identify and remove the twelve additional rivets that attach the web P/N 109-0320-96-71 (or P/N 109-0320-96-505) to the forward and aft bulkheads. They must be removed to allow installation of the external butt-strap P/N 109-0952-67-123.
33. Remove the rivets that have been identified and marked in the previous Steps 31 and 32.

NOTE

Insert a thin steel sheet between the web and the forward and aft bulkheads to avoid damages while cutting the metal.

34. With reference to Figure 42 thru Figure 44, cut the web P/N 109-0320-96-71 (or P/N 109-0320-96-505).

NOTE

Perform the following Steps from 35 to 47 ONLY if the angle P/N 109-0320-96-73 (or P/N 109-0320-96-507) is damaged, otherwise skip to Step 48.

35. With reference to Figure 43, identify and mark the cutting lines for angle P/N 109-0320-96-73 (or P/N 109-0320-96-507). The slant of cut shown in figure is indicative. Always make sure that cutting lines are equally spaced from the adjacent rivets. Identify all the rivets that attach the portion of angle to other structural elements of the post.
36. With reference to Figure 43, remove the rivets identified in the previous Step 35.
37. With reference to Figure 41 and Figure 42, remove the four rivets that attach the two nut-plates to the forward side of the post. Discard the two nut-plates.

38. With reference to Figure 45 and Figure 46, cut the angle P/N 109-0320-96-73 (or P/N 109-0320-96-507).
39. With reference to Figure 42 thru Figure 47, put the new angle P/N 109-0952-67-119, the new butt strap P/N 109-0952-67-121, the web P/N 109-0952-67-125 and the doubler P/N 109G5330R01-205 in position on interior of the post. Mark the exact length of the angle P/N 109-0952-67-119, depending on the cutting position of the existing angle.
40. With reference to Figure 45 and Figure 46, mark the exact length of the internal butt-strap P/N 109-0952-67-121.

NOTE

When marking the position of the rivet holes, make sure that the distance between the hole centre and the edge of the sheet is at least 2.5 times the diameter of the rivet.

41. Remove the new angle P/N 109-0952-67-119 and the new butt strap P/N 109-0952-67-121 and cut them to the exact length as defined in Steps 39 and 40. Reinstall the items in position and mark the position of the rivet holes.
42. Drill the holes to attach the new angle P/N 109-0952-67-119, the new butt strap P/N 109-0952-67-121, the web P/N 109-0952-67-125 and the doubler P/N 109G5330R01-205 to forward and aft bulkhead P/N 109-0320-96. Attach the parts in position with Cleco fasteners.
43. Put the web P/N 109-0952-67-125 in position on the post. Drill the holes to secure the new internal butt strap P/N 109-0952-67-121.
44. With reference to Figure 43, put the external butt-strap P/N 109-0952-67-123 in position. If necessary, adapt the shape to the profile of the post to allow the correct installation. Mark and drill the attachment holes.
45. Remove the paint from the existing web P/N 109-0320-96-71 (or P/N 109-0320-96-505) and from the new web P/N 109-0952-67-125 in the area of installation of the external butt-strap P/N 109-0952-67-123.

NOTE

For accessibility reason, it is allowed to install rivets P/N A879A05L150 on opposite direction (rivet from outside to inside STA1815 honeycomb).

46. With reference to Figure 42 thru Figure 47, put in position the new angle P/N 109-0952-67-119, the new butt strap P/N 109-0952-67-121, the web P/N 109-0952-67-125 and the doubler P/N 109G5330R01-205. Install by means of adhesive EA9309.3NA. Starting from the forward side of the post, install the rivets. Seal edges by means of sealant PROSEAL 890B2 or MC780 B-2.

47. With reference to Figure 42 thru Figure 44, install the external butt-strap P/N 109-0952-67-123 to the post by means of adhesive EA9309.3NA and rivets. Seal edges by means of sealant PROSEAL 890B2 or MC780 B-2.

NOTE

Perform the following Steps from 48 to 54 ONLY if the angle P/N 109-0320-96-73 (or P/N 109-0320-96-507) is undamaged.

48. With reference to Figure 41 and Figure 42, remove the four rivets that attach the two nut-plates to the forward side of the post. Discard the two nut-plates.
49. With reference to Figure 42 thru Figure 44, put the web P/N 109-0952-67-125 and the doubler P/N 109G5330R01-205 in position on interior of the post.

NOTE

When marking the position of the rivet holes, make sure that the distance between the hole centre and the edge of the sheet is at least 2.5 times the diameter of the rivet.

50. Drill the holes to attach the the web P/N 109-0952-67-125 and the doubler P/N 109G5330R01-205 to forward and aft bulkhead P/N 109-0320-96. Attach the parts in position with Cleco fasteners.
51. With reference to Figure 43, put the external butt-strap P/N 109-0952-67-123 in position. If necessary, adapt the shape to the profile of the post to allow the correct installation. Mark and drill the attachment holes.
52. Remove the paint from the existing web P/N 109-0320-96-71 (or P/N 109-0320-96-505) and from the new web P/N 109-0952-67-125 in the area of installation of the external butt-strap P/N 109-0952-67-123.

NOTE

For accessibility reason, it is allowed to install rivets P/N A879A05L150 on opposite direction (rivet from outside to inside STA1815 honeycomb).

53. With reference to Figure 42 thru Figure 44, put in position the web P/N 109-0952-67-125 and the doubler P/N 109G5330R01-205. Install by means of adhesive EA9309.3NA. Starting from the forward side of the post, install the rivets. Seal edges by means of sealant PROSEAL 890B2 or MC780 B-2.
54. With reference to Figure 42 thru Figure 44, install the external butt-strap P/N 109-0952-67-123 to the post by means of adhesive EA9309.3NA and rivets. Seal edges by means of sealant PROSEAL 890B2 or MC780 B-2.
55. With reference to Figure 19, reinstall and bond with adhesive EA9309.3NA all the shims

that were installed under the lower end of forward LH bulkhead P/N 109-0320-96.

NOTE

Make sure that the rivets in the zone of installation of the torque tube support P/N 109-0011-18-1 have the countersunk head on both sides. Make sure that the head does not protrude over the surface. Flush the heads if necessary.

NOTE

Reuse the removed part if it is not damaged.

56. With reference to Figure 38, Figure 39 and Figure 48, put the forward cap P/N 109-0320-90-207 or -507 in position and bond by means of adhesive EA9309.3NA and PROSEAL 890B2. Install the forward cap by means of the indicated rivets. Seal the edges of the forward LH cap by means of sealant PROSEAL 890B2 or MC780 B-2.
57. With reference to Figure 41 and 42, install the two nutplates P/N MS21071L08 in the indicated position by means of the rivets.
58. Temporarily put the LH post lower fairing P/N 109-0324-30-201 and the LH lower fairing P/N 109-0324-25-303 in position and drill the rivet holes in the upper part of the forward LH cap P/N 109-0320-90-207 or -507.
59. Touch-up the exposed areas of the repaired zones with primer and paint to restore the original aspect.
60. With reference to Figure 13, bond with PROSEAL 890B2 then attach with rivets the LH lower fairing P/N 109-0324-25-303. Make sure that that the drain holes in the fairing are not plugged by the sealant.
61. With reference to Figure 13, bond with PROSEAL 890B2 then attach with rivets the LH post lower fairing P/N 109-0324-30-201. Make sure that that the drain holes in the fairing are not plugged by the sealant.
62. In accordance with MM Paragraphs 07-30-1 or 07-30-2, lay down the helicopter.
63. Reinstall the cockpit/passenger doors caution system switch on the LH post centre fairing P/N 109-0324-29-101 using the related screws. Put the shims (if any) in their original position.
64. With reference to Figure 13, reinstall the LH post centre fairing P/N 109-0324-29-101 using the related attaching screws.
65. If originally installed, reinstall the sill-liner or apply the anti-slip paint on the upper side of the fairings P/N 109-0324-25-303 and P/N 109-0324-30-201.
66. Reinstall the cockpit and passenger doors seals.
67. In accordance with MM Paragraph 21-21-1, reinstall the air conditioning duct located

inside the door lower sill.

68. Reinstall the collective stick connector removed at Step 13.
69. In accordance with MM Paragraphs 67-00-12 and 67-11-9, reinstall the collective control torque tube.
70. If removed (Ref. Step 7), in accordance with MM Paragraphs 67-00-12 and 67-11-9, reinstall the co-pilot collective control lever.
71. With reference to Figure 11 and Figure 12, reinstall the collective control rod assy P/N 109-0032-04-41 and the tail rotor control rod assy P/N 109-0032-02-25 as follows:

CAUTION

Apply the maximum care to prevent any damage to the control rod caused by rubbing with other parts of the helicopter.

- 71.1 Put the collective control rod assy in position on interior of the left cabin post by inserting it from the top. Observe the correct sense of installation, as identified in previous Step 2.8.
- 71.2 Attach the upper end of the collective control rod assy to the lever using the bolt P/N AN174-12, the washer P/N A160A0432K (under bolt head and with countersunk side toward the bolt head), the washer P/N AN960-PD416 (under the nut) and the nut P/N MS17825-4. Torque the nut to 3.4 thru 4.5 Nm and install a new cotter pin P/N MS24665-153.
- 71.3 Attach the lower end of the collective control rod assy to the lever using the bolt P/N AN174-12, the washer P/N A160A0432K (under bolt head and with countersunk side toward the bolt head), the washer P/N AN960-PD416 (under the nut) and the nut P/N MS17825-4. If necessary, move slightly the collective control lever as necessary to allow the insertion of the bolt. Torque the nut to 3.4 thru 4.5 Nm and install a new cotter pin P/N MS24665-153.

CAUTION

Apply the maximum care to prevent any damage to the control rod caused by rubbing with other parts of the helicopter.

- 71.4 Put the tail rotor control rod assy in position on interior of the left cabin post by inserting it from the top. Observe the correct sense of installation, as identified in previous Step 2.8.

- 71.5 Attach the upper end of the tail rotor control rod assy to the lever using the bolt P/N AN174-12, the washer P/N AN960-PD416 under the nut and the nut P/N MS17825-4. Torque the nut to 3.4 thru 4.5 Nm and install a new cotter pin P/N MS24665-151.
 - 71.6 Attach the lower end of the tail rotor control rod assy to the lever using the bolt P/N AN174-12, the washer P/N AN960-PD416 under the nut and the nut P/N MS17825-4. If necessary, move slightly the pedals as necessary to allow the insertion of the bolt. Torque the nut to 3.4 thru 4.5 Nm and install a new cotter pin P/N MS24665-151.
 - 71.7 Remove the masking tape that has been put on the rods to identify the direction of installation (ref. Step 2.8).
 - 71.8 Perform a duplicate inspection of installation of the control rods. The duplicate inspection must include, but is not limited to, correct assembly, security, correct application of cotter pins, thread engagement and protrusion, and a functional check for complete range, freedom of movement and operation in correct sense.
72. For the collective installation affected by collective control rod assy P/N 109-0032-02-41 and Torque Tube removal and re-installation, perform the following step of MM Paragraph 67-00-25 (ref. Figures 3 thru 10):
- Put the minimum collective lever positioning Tool (LSE 198) in its position on the interseat console;
 - Move the pilot collective stick down and put the lower side of the stick against the pin of the tool. Being collective control rod assy P/N 109-0032-02-41 mechanically connected to the lower and upper lever, as per Step 71.2 and 71.3, also the mixing unit will be moved FWD. Pay attention to provide hydraulic power supply at 1500 PSI before moving the stick;
 - Check that the minimum Collective Stop is engaged as per Step X. If not, apply the following Step from Step A up to Step H;
 - Remove the Tool (minimum collective lever) from the cockpit;
 - Loosen the adjustable friction;
 - Move the collective stick three or four times. Make sure that the collective controls are free to operate without friction against the structure.
73. Perform an operational test of the collective control system, and of the tail rotor control system, to make sure that the control linkages move freely.
74. Reinstall all the access panels you have removed to perform the repair.

NOTE

For A109E helicopters from S/N 11001 thru S/N 11600 included.

75. Panel P/N 109-0320-90-7, removed at Step 10, can be reused after removing thoroughly any trace of sealant using a plastic scraper and a cloth moistened with solvent MIL-PRF-680 TY II.

NOTE

For A109E helicopters from S/N 11601 thru S/N 11674 included.

76. Panel P/N 109-0320-90-505, removed at Step 10, can be reused after removing thoroughly any trace of sealant using a plastic scraper and a cloth moistened with solvent MIL-PRF-680 TY II.
77. Reinstall the collective lever guard assy P/N 109-0700-25-127 (if the helicopter is equipped with dual control) or the fairing P/N 109-0011-28-1 (if the helicopter is not equipped with dual control).
78. Reinstall the support panels located under the pilot and co-pilot seat. Reinstall also the centre panel located between the seats and any control located on it (e.g. friction knob, cargo hook release handle).
79. Reinstall the access door P/N 109-0322-10-13 on the upper part of the fuselage, over the door post, and move the platform away from helicopter.
80. Reinstall the access panel P/N 109-0320-90-63.
81. In accordance with MM Paragraph 21-21-1, reinstall the air distribution duct P/N 109-0710-32-105 on the door post.
82. With reference to the pertinent MM Paragraph, reinstall all the items of equipment/furnishing that were removed to gain access to work area.
83. If originally installed, in accordance with MM Paragraph 25-21-12, reinstall the forward passenger seat.
84. In accordance with MM Paragraph 25-11-9, reinstall the pilot and co-pilot seat.
85. If originally installed, in accordance with MM Paragraphs 25-81-7 and 25-81-9, reinstall the cockpit and passenger compartment soundproofing panels or the moquette lining.
86. In accordance with MM Paragraph 52-11-9, reinstall the pilot and co-pilot doors and close the passenger compartment doors.
87. In accordance with MM Paragraph 52-71-6, perform an operational test of the cockpit/passenger doors caution system.
88. In accordance with weight and balance changes, update the Chart A (see Rotorcraft Flight Manual, Part II, section 6).

89. Return the helicopter to a ready to flight condition and record for compliance with Part IV of this Service Bulletin on the helicopter logbook.
90. Gain access to My Communications section on Leonardo WebPortal and compile the "Service Bulletin Application Communication".

As an alternative, send the attached compliance form to the following mail box:

engineering.support.lhd@leonardo.com

and (for North, Central and South America) also to:

AWPC.Engineering.Support@leonardocompany.us

PART V

NOTE

If the helicopter's LH post has been repaired in accordance with Part III (RH side) of this Service Bulletin, or in accordance with repair drawing P/N 109-0952-67-102 (RH side), the helicopter could install web with P/N 109-0320-96-72 (or P/N 109-0320-96-506 or P/N 109-0952-67-109), and RH angle with P/N 109-0320-96-74 (or P/N 109-0320-96-508 or P/N 109-0952-67-111).

NOTE

If undamaged, parts P/N 109-0320-96-72 (or P/N 109-0320-96-506) and 109-0320-96-74 (or P/N 109-0320-96-508) may not be cut and reused in their respective position.

1. In accordance with MM Paragraph 00-20-1, prepare the helicopter on ground for a safe maintenance. Disconnect the battery, all electrical power sources and/or the external power supply.
2. With reference to Figure 25 and Figure 26, remove the lateral cyclic control rod assy P/N 109-0032-19-101 and the longitudinal cyclic control rod assy P/N 109-0032-07-01 as follows:
 - 2.1 In accordance with MM Paragraph 25-11-9, remove the pilot seat.
 - 2.2 If installed, in accordance with MM Paragraph 25-21-12, remove the forward passenger seat.
 - 2.3 In accordance with the pertinent MM Paragraph, remove any other item of equipment/furnishing that might prevent the access to the work area.
 - 2.4 If installed, in accordance with MM Paragraphs 25-81-7 and 25-81-9, remove the cockpit and passenger compartment soundproofing panels or the moquette lining that might prevent the access to the inspection zone.
 - 2.5 In accordance with MM Paragraph 21-21-1, remove the air distribution duct P/N 109-0710-32-105 from the left door post.
 - 2.6 Remove the access panel P/N 109-0320-90-206.
 - 2.7 Remove the access door P/N 109-0322-10-14 on the upper part of the fuselage, over the door post.
 - 2.8 Using masking tape, identify the position and the sense of installation of each control rod assy.

- 2.9 With reference to Figure 25, on the lower end of the lateral cyclic control rod assy, remove the cotter pin, the nut, the bolt and the washers that attach the lower end of the control rod assy to the lever. Discard the cotter pin. If necessary, move slightly the cyclic control stick to allow an easy removal of the bolt.

CAUTION

During the hardware removing, keep the rod assy to prevent it from falling.

- 2.10 With reference to Figure 25, on the upper end of the lateral cyclic control rod assy, remove the cotter pin, the nut, the bolt and the washers that attach the upper end of the control rod assy to the lever. Discard the cotter pin.

NOTE

Do not change the length of the lateral cyclic control rod assy.

CAUTION

Apply the maximum care to prevent any damage to the control rod caused by rubbing with other parts of the helicopter.

- 2.11 Withdraw the lateral cyclic control rod assy toward the upper side of helicopter.

- 2.12 With reference to Figure 26, on the lower end of the longitudinal cyclic control rod assy, remove the cotter pin, the nut, the bolt and the washers that attach the lower end of the control rod assy to the lever. Discard the cotter pin.

CAUTION

During the hardware removing, keep the rod assy to prevent it from falling.

- 2.13 With reference to Figure 26, on the upper end of the longitudinal cyclic control rod assy, remove the cotter pin, the nut, the bolt and the washers that attach the upper end of the control rod assy to the lever. Discard the cotter pin.

NOTE

Do not change the length of the longitudinal cyclic control rod assy.

CAUTION

Apply the maximum care to prevent any damage to the control rod caused by rubbing with other parts of the helicopter.

- 2.14 Withdraw the longitudinal cyclic control rod assy toward the upper side of helicopter.
3. In accordance with MM Paragraph 52-11-9, remove the pilot and co-pilot door. Open both the passenger compartment doors and lock them in opened position.
4. Remove the pilot door seal assy P/N 109-0360-88-110 and the passenger door seal assy P/N 109-0360-86-110. Remove any trace of adhesive and rubber from installation areas using a plastic scraper and a soft cloth moistened with solvent.
5. In accordance with MM Paragraph 25-11-9, remove the co-pilot seat.
6. Remove the support panels located under the pilot and co-pilot seat. Remove also the centre panel located between the seats and any control located on it (e.g. friction knob, cargo hook release handle).
7. Remove and retain for later re-use all the access panels located on the door sill
8. With reference to Figure 2, remove the access panels P/N 109-0320-96-522 and P/N 109-0320-96-310 located on the post. Retain all the fixing hardware for later reuse.
9. Remove the air conditioning duct located inside the door lower sill. Cap thoroughly the open ends of the adjacent ducts to prevent any unwanted entry of foreign materials in the air conditioning system.
10. In accordance with MM Paragraphs 67-00-12 and 67-12-1, remove and retain for later reuse the following components of the flight control system:
 - Lateral cyclic control rod P/N 109-0032-01-1;
 - Longitudinal cyclic control rod P/N 109-0032-03-1;
 - Lateral cyclic lever P/N 109-0020-17-1;
 - Lateral cyclic control rod P/N 109-0032-02-1.
11. With reference to figure 13, remove the RH post centre fairing P/N 109-0324-29-102 by removing the related attaching screws.
12. Remove the cockpit/passenger doors caution system switch from the fairing removed at previous Step 11 by removing the two attaching screws. Leave the switch attached to the wire. Take note of quantity of shims below the switch in order to allow the reinstallation in their original position.
13. If applied, remove any sill-liner or anti-slip paint from the upper side of the fairings P/N 109-0324-25-304 and 109-0324-30-202.
14. In accordance with MM Paragraphs 07-30-1 or 07-30-2, raise the helicopter using the lifting device P/N 109-3900-01-1 connected to a suitable crane/hoist and put the cable in tension.
15. With reference to Figure 27, remove the RH lower fairing P/N 109-0324-25-304 by drilling-out the attaching rivets. Break the sealant layer between the fairing and the structure using

- a thin blade or putty knife.
16. With reference to Figure 27, remove the RH post lower fairing P/N 109-0324-30-202 by drilling-out the attaching rivets. Break the sealant layer between the fairing and the structure using a thin blade or putty knife.
 17. Remove any trace of sealant from the structure and from the inner side of the fairings P/N 109-0324-25-304 and 109-0324-30-202 using a plastic scraper or putty knife. Clean thoroughly using Scotch-Brite and a clean, lint-free cloth moistened with cleaning solvent MIL-PRF-680 TY II.
 18. Drill-out all the rivets that attach the forward RH cap, the forward RH protection P/N 109-0311-40-134 and the doubler P/N 109-0311-40-128 (under the forward RH protection P/N 109-0311-40-134). Break the sealant layer between the cap, the protection, the doubler and the structure using a thin blade or putty knife. Remove any trace of sealant from the structure using a plastic scraper or putty knife. Clean thoroughly using Scotch-Brite and a clean, lint-free cloth moistened with cleaning solvent MIL-PRF-680 TY II.
 19. If installed, remove and retain for later reuse any additional shim that is installed between the rear part of the forward RH cap and the post structure.
 20. With reference to Figure 38, remove the forward RH cap P/N 109-0320-90-208. Discard only if the part is damaged.
 21. With reference to Figure 38, remove the right cap P/N 109-0320-90-54.
 22. With reference to Figure 40 View E-E, temporarily remove the FWD bulkhead RH P/N 109-0320-96-312, the RH core P/N 109-0320-90-118 and the RH angle P/N 109-0320-90-42.
 23. With reference to Figure 41, remove the filler P/N 109-0320-90-175.
 24. With reference to Figure 38, install the RH angle P/N 109G5307P39-114 by means of adhesive EA9309.3NA.
 25. With reference to Figure 41, install the stiffener machined RH 109G5330A25-102 by means of adhesive EA9309.3NA.
 26. With reference to Figure 37 thru Figure 41, install the following parts by means of the indicated rivets:
 - the left cap P/N 109G5307P39-116;
 - the doubler P/N 109G5307P39-117;
 - the previously removed FWD bulkhead RH P/N 109-0320-96-312,
 - the previously removed RH core P/N 109-0320-90-118;
 - the previously removed LH angle P/N 109-0320-90-42.
 27. With reference to Figure 42 thru Figure 47, find and mark the cutting line for the web P/N 109-0320-96-72 (or P/N 109-0320-96-506). Identify and remove all the rivets that

attach the web to RH angle P/N 109-0320-96-74 (or P/N 109-0320-96-508), to forward and aft bulkhead P/N 109-0320-96, and to RH ribs P/N 109-0320-96-48 and P/N 109-0320-96-50. Using a putty knife, break the sealant/adhesive between the parts.

28. With reference to Figure 43, identify and remove the twelve additional rivets that attach the web P/N 109-0320-96-72 to the forward and aft bulkheads. They must be removed to allow installation of the external butt-strap P/N 109-0952-67-115.
29. Remove the rivets that have been identified and marked in the previous Steps 27 and 28.

NOTE

Insert a thin steel sheet between the web and the forward and aft bulkheads to avoid damages while cutting the metal.

30. With reference to Figure 42 thru Figure 44, cut the web P/N 109-0320-96-72 (or P/N 109-0320-96-506).

NOTE

Perform the following Steps from 31 to 43 ONLY if the angle P/N 109-0320-96-74 (or P/N 109-0320-96-508) is damaged, otherwise skip to Step 44.

31. With reference to Figure 43, identify and mark the cutting lines for angle P/N 109-0320-96-74 (or P/N 109-0320-96-508). The slant of cut shown in figure is indicative. Always make sure that cutting lines are equally spaced from the adjacent rivets. Identify all the rivets that attach the portion of angle to other structural elements of the post.
32. With reference to Figure 43, remove the rivets identified in the previous Step 31.
33. With reference to Figure 41 and Figure 42, remove the four rivets that attach the two nut-plates to the forward side of the post. Discard the two nut-plates.
34. With reference to Figure 41 and Figure 42, cut the angle P/N 109-0320-96-74 (or P/N 109-0320-96-508).
35. With reference to Figure 42 thru Figure 47, put the new angle P/N 109-0952-67-111, the new internal butt strap P/N 109-0952-67-113, the web P/N 109-0952-67-109 the doubler P/N 109G5330R01-206 in position on interior of the post. Mark the exact length of the angle P/N 109-0952-67-111, depending on the cutting position of the existing angle.
36. With reference to Figure 45 and Figure 46, mark the exact length of the internal butt-strap P/N 109-0952-67-113.

NOTE

When marking the position of the rivet holes, make sure that the distance between the hole centre and the edge of the sheet is at least 2.5 times the diameter of the rivet.

37. Remove the new angle P/N 109-0952-67-111 and the new butt strap P/N 109-0952-67-113 and cut them to the exact length as defined in Steps 35 and 36 above. Reinstall the items in position and mark the position of the rivet holes.
38. Drill the holes to attach the new angle P/N 109-0952-67-111, the new butt strap P/N 109-0952-67-113, the web P/N 109-0952-67-109 and the doubler P/N 109G5330R01-206 to forward and aft bulkhead P/N 109-0320-96. Attach the parts in position with Cleco fasteners.
39. Put the web P/N 109-0952-67-109 in position on the post. Drill the holes to secure the new butt strap P/N 109-0952-67-113.
40. With reference to Figure 42, put the external butt-strap P/N 109-0952-67-115 in position. If necessary, adapt the shape to the profile of the post to allow the correct installation. Mark and drill the attachment holes.
41. Remove the paint from the existing web P/N 109-0320-96-72 (or P/N 109-0320-96-506) and from the new web P/N 109-0952-67-109 in the area of installation of the external butt-strap P/N 109-0952-67-115.

NOTE

For accessibility reason, it is allowed to install rivets P/N A879A05L150 on opposite direction (rivet from outside to inside STA1815 honeycomb).

42. With reference to Figure 42 thru Figure 47, put in position the new angle P/N 109-0952-67-111, the new butt strap P/N 109-0952-67-113, the web P/N 109-0952-67-109 and the doubler P/N 109G5330R01-205. Install by means of adhesive EA9309.3NA. Starting from the forward side of the post, install the rivets. Seal edges by means of sealant PROSEAL 890B2 or MC780 B-2.
43. With reference to Figure 42 thru Figure 44, install the external butt-strap P/N 109-0952-67-115 to the post by means of adhesive EA9309.3NA and rivets. Seal edges by means of sealant PROSEAL 890B2 or MC780 B-2.

NOTE

Perform the following Steps from 44 to 50 ONLY if the angle P/N 109-0320-96-74 (or P/N 109-0320-96-508) is undamaged.

44. With reference to Figure 41 and Figure 42, remove the four rivets that attach the two

nut-plates to the forward side of the post. Discard the two nut-plates.

45. With reference to Figure 42 thru Figure 44, put the web P/N 109-0952-67-109 the doubler P/N 109G5330R01-206 in position on interior of the post.

NOTE

When marking the position of the rivet holes, make sure that the distance between the hole centre and the edge of the sheet is at least 2.5 times the diameter of the rivet.

46. Drill the holes to attach the web P/N 109-0952-67-109 and the doubler P/N 109G5330R01-206 to forward and aft bulkhead P/N 109-0320-96. Attach the parts in position with Cleco fasteners.
47. With reference to Figure 42, put the external butt-strap P/N 109-0952-67-115 in position. If necessary, adapt the shape to the profile of the post to allow the correct installation. Mark and drill the attachment holes.
48. Remove the paint from the existing web P/N 109-0320-96-72 (or P/N 109-0320-96-506) and from the new web P/N 109-0952-67-109 in the area of installation of the external butt-strap P/N 109-0952-67-115.

NOTE

For accessibility reason, it is allowed to install rivets P/N A879A05L150 on opposite direction (rivet from outside to inside STA1815 honeycomb).

49. With reference to Figure 42 thru Figure 44, put in position the web P/N 109-0952-67-109 and the doubler P/N 109G5330R01-205. Install by means of adhesive EA9309.3NA. Starting from the forward side of the post, install the rivets. Seal edges by means of sealant PROSEAL 890B2 or MC780 B-2.
50. With reference to Figure 42 thru Figure 44, install the external butt-strap P/N 109-0952-67-115 to the post by means of adhesive EA9309.3NA and rivets. Seal edges by means of sealant PROSEAL 890B2 or MC780 B-2.
51. With reference to Figure 32, reinstall and bond with EA9309.3NA all the shims that were installed under the lower end of forward RH bulkhead P/N 109-0320-96.

NOTE

Make sure that the rivets in the zone of installation of the torque tube support P/N 109-0011-18-1 have the countersunk head on both sides. Make sure that the head does not protrude over the surface. Flush the heads if necessary.

NOTE

Reuse the removed part if it is not damaged.

52. With reference to Figure 38, Figure 39 and Figure 48, put the forward cap P/N 109-0320-90-208 in position and bond by means of adhesive EA9309.3NA and PROSEAL 890B2. Install the forward cap by means of the indicated rivets. Seal the edges of the forward LH cap by means of sealant PROSEAL 890B2 or MC780 B-2.
53. With reference to Figure 41 and 42, install the two nutplates MS21071L08 in the indicated position by means of the rivets.
54. Temporarily put the RH post lower fairing P/N 109-0324-30-202 and the RH lower fairing P/N 109-0324-25-304 in position and drill the rivet holes in the upper part of the forward RH cap P/N 109-0320-90-208.
55. Touch-up the exposed areas of the repaired zones with primer and paint to restore the original aspect.
56. With reference to Figure 27, bond with PROSEAL 890B2 then attach with rivets the RH lower fairing P/N 109-0324-25-304. Make sure that that the drain holes in the fairing are not plugged by the sealant.
57. With reference to Figure 27, bond with PROSEAL 890B2 then attach with rivets the RH post lower fairing P/N 109-0324-30-202. Make sure that that the drain holes in the fairing are not plugged by the sealant.
58. In accordance with MM Paragraphs 07-30-1 or 07-30-2, lay down the helicopter.
59. Reinstall the cockpit/passenger doors caution system switch on the RH post centre fairing P/N 109-0324-29-102 using the related screws. Put the shims (if any) in their original position.
60. With reference to Figure 27, reinstall the LH post centre fairing P/N 109-0324-29-102 using the related attaching screws.
61. If originally installed, reinstall the sill-liner or apply the anti-slip paint on the upper side of the fairings P/N 109-0324-25-304 and 109-0324-30-202.
62. Reinstall the cockpit and passenger doors seals.
63. In accordance with MM Paragraphs 67-00-12 and 67-12-1, reinstall the following components of the flight control system:

- Lateral cyclic control rod P/N 109-0032-01-1;
- Longitudinal cyclic control rod P/N 109-0032-03-1;
- Lateral cyclic lever P/N 109-0020-17-1;
- Lateral cyclic control rod P/N 109-0032-02-1.

64. In accordance with MM Paragraph 21-21-1, reinstall the air conditioning duct located inside the door lower sill.

65. With reference to Figure 25 and Figure 26, reinstall the lateral cyclic control rod assy and the longitudinal cyclic control rod assy P/N 109-0032-07-01 as follows:

CAUTION

Apply the maximum care to prevent any damage to the control rod caused by rubbing with other parts of the helicopter.

65.1 Put the longitudinal control rod assy in position on interior of the right cabin post by inserting it from the top. Observe the correct sense and position of installation, as identified in previous Step 2.8.

65.2 With reference to Figure 26, attach the upper end of the longitudinal control rod to the lever using the bolt P/N AN174-12, one washer P/N AN960-PD416 (under the bolt head), one washer P/N AN960-PD416 under the nut, and the nut P/N MS17825-4. Torque the nut to 3.4 thru 4.5 Nm and install a new cotter pin P/N MS24665-153. If necessary, install one additional washer P/N AN960-PD416 under the nut to obtain the correct engagement of the nut.

65.3 With reference to Figure 26, attach the lower end of the longitudinal control rod to the lever using the bolt P/N AN174-12, one washer P/N AN960-PD416 (under the bolt head), one washer P/N AN960-PD416 under the nut, and the nut P/N MS17825-4. If required, move slightly cyclic control stick as necessary to allow the insertion of the bolt. Torque the nut to 3.4 thru 4.5 Nm and install a new cotter pin P/N MS24665-153. If necessary, install one additional washer P/N AN960-PD416 under the nut to obtain the correct engagement of the nut.

CAUTION

Apply the maximum care to prevent any damage to the control rod caused by rubbing with other parts of the helicopter.

65.4 Put the lateral control rod assy in position on interior of the right cabin post by inserting it from the top. Observe the correct sense and position of installation, as identified in previous Step 2.8.

- 65.5 With reference to Figure 25, attach the upper end of the lateral control rod to the lever using the bolt P/N AN174-12, one washer P/N AN960-PD416 (under the bolt head), one washer P/N AN960-PD416 under the nut, and the nut P/N MS17825-4. Torque the nut to 3.4 thru 4.5 Nm and install a new cotter pin P/N MS24665-153. If necessary, install one additional washer P/N AN960-PD416 under the nut to obtain the correct engagement of the nut.
- 65.6 With reference to Figure 25, attach the lower end of the lateral control rod) to the lever using the bolt P/N AN174-12, one washer P/N AN960-PD416 (under the bolt head), one washer P/N AN960-PD416 under the nut, and the nut P/N MS17825-4. If required, move slightly cyclic control stick as necessary to allow the insertion of the bolt. Torque the nut to 3.4 thru 4.5 Nm and install a new cotter pin P/N MS24665-153. If necessary, install one additional washer P/N AN960-PD416 under the nut to obtain the correct engagement of the nut.
- 65.7 Remove the masking tape that has been put on the rods to identify the direction of installation (ref. Step 2.8).
- 65.8 Perform a duplicate inspection of installation of the control rods. The duplicate inspection must include, but is not limited to, correct assembly, security, correct application of cotter pins, thread engagement and protrusion, and a functional check for complete range, freedom of movement and operation in correct sense.
66. To check that the Fixed Flight Component have been properly re-installed, get access to the cyclic control stick on the left side of the cockpit, and with hydraulic power supply at 1500 PSI perform the following Step of MM Paragraph 67-00-26, (ref. Figures 3 thru 10):
- Disengage the spring P/N 109-0020-36 from the bracket;
 - Fully loosen the friction control;
 - Step B;
 - Step C. If rigging pins do not fit, apply MM Paragraph 67-00-26;
 - Engage the spring P/N 109-0020-36 on bracket;
 - Step H;
 - Do the adjustment of the fixed frictions of the cyclic control system.
67. Perform an operational test of the cyclic control system to make sure that the control linkages move freely.
68. Reinstall all the access panels you have removed to perform the repair.
69. Panel P/N 109-0320-90-8, removed at Step 7, can be reused after removing thoroughly any trace of sealant using a plastic scraper and a cloth moistened with solvent MIL-PRF-680 TY II.
70. Reinstall the support panels located under the pilot and co-pilot seat. Reinstall also the

centre panel located between the seats and any control located on it (e.g. friction knob, cargo hook release handle).

71. Reinstall the access door P/N 109-0322-10-14 on the upper part of the fuselage, over the door post, and move the platform away from helicopter.
72. Reinstall the access panel P/N 109-0320-90-206.
73. In accordance with MM Paragraph 21-21-1, reinstall the air distribution duct P/N 109-0710-32-106 on the door post.
74. With reference to the pertinent MM Paragraph, reinstall all the items of equipment/furnishing that were removed to gain access to work area.
75. If originally installed, in accordance with MM Paragraph 25-21-12, reinstall the forward passenger seat.
76. In accordance with MM Paragraph 25-11-9, reinstall the pilot and co-pilot seat.
77. If originally installed, in accordance with MM Paragraphs 25-81-7 and 25-81-9, reinstall the cockpit and passenger compartment soundproofing panels or the moquette lining.
78. In accordance with MM Paragraph 52-11-9, reinstall the pilot and co-pilot doors and close the passenger compartment doors.
79. In accordance with MM Paragraph 52-71-6, perform an operational test of the cockpit/passenger doors caution system.
80. Return the helicopter to a ready to flight condition and record for compliance with Part V of this Service Bulletin on the helicopter logbook.
81. Gain access to My Communications section on Leonardo WebPortal and compile the "Service Bulletin Application Communication".

As an alternative, send the attached compliance form to the following mail box:

engineering.support.lhd@leonardo.com

and (for North, Central and South America) also to:

AWPC.Engineering.Support@leonardocompany.us

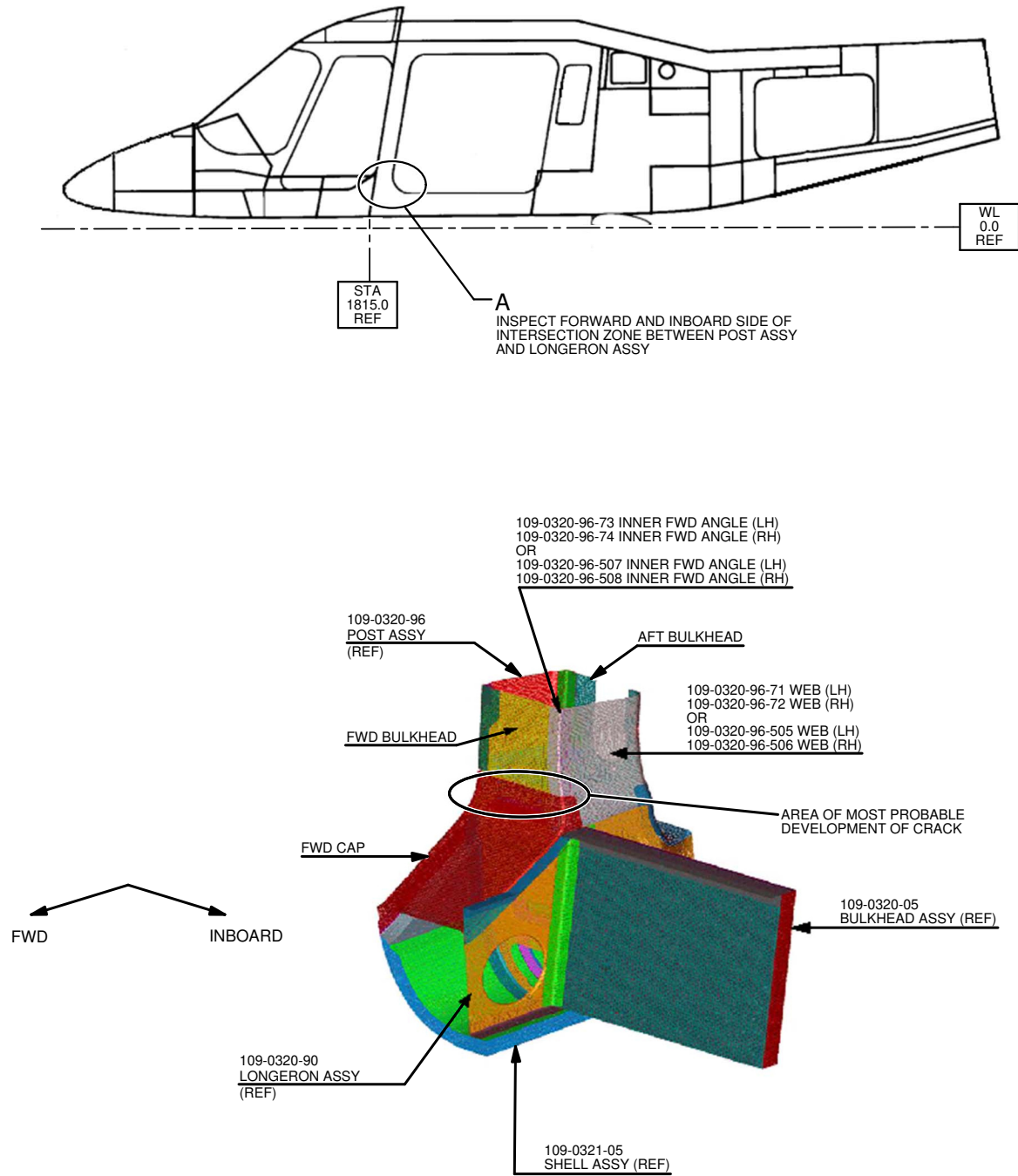

DETAIL A
RIGHT SIDE SHOWN
LEFT SIDE SYMMETRICAL
STRUCTURES AND SYSTEMS ARE PARTIALLY
OMITTED FOR BETTER CLARITY PURPOSES

Figure 1

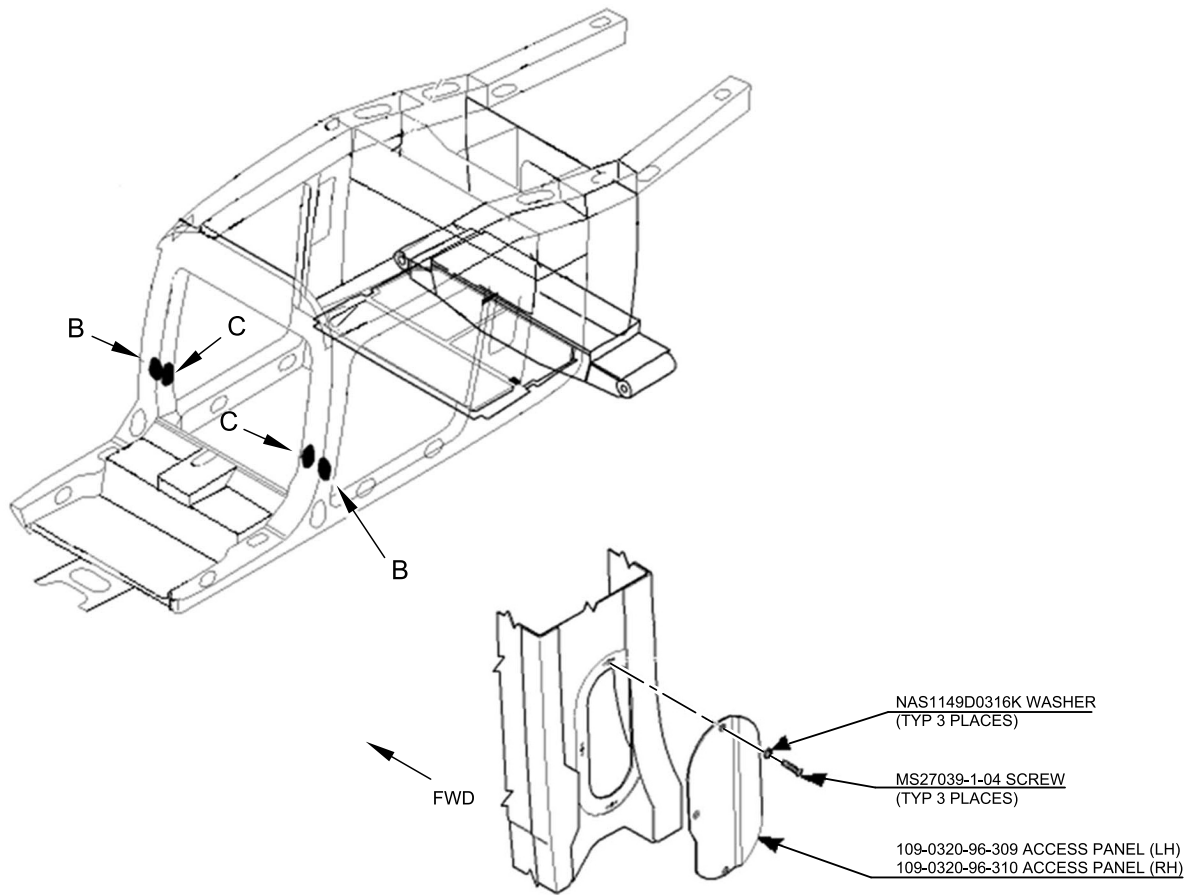

DETAIL B

STRUCTURES AND SYSTEMS ARE PARTIALLY OMITTED FOR BETTER CLARITY PURPOSES

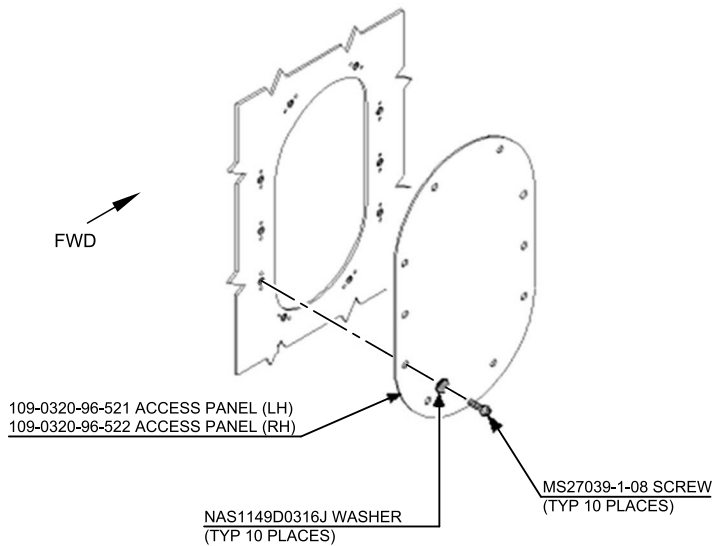

DETAIL C

STRUCTURES AND SYSTEMS ARE PARTIALLY OMITTED FOR BETTER CLARITY PURPOSES

Figure 2

S.B. N°109EP-173 ALERT
DATE: November 10, 2020
REVISION: B - August 24, 2023

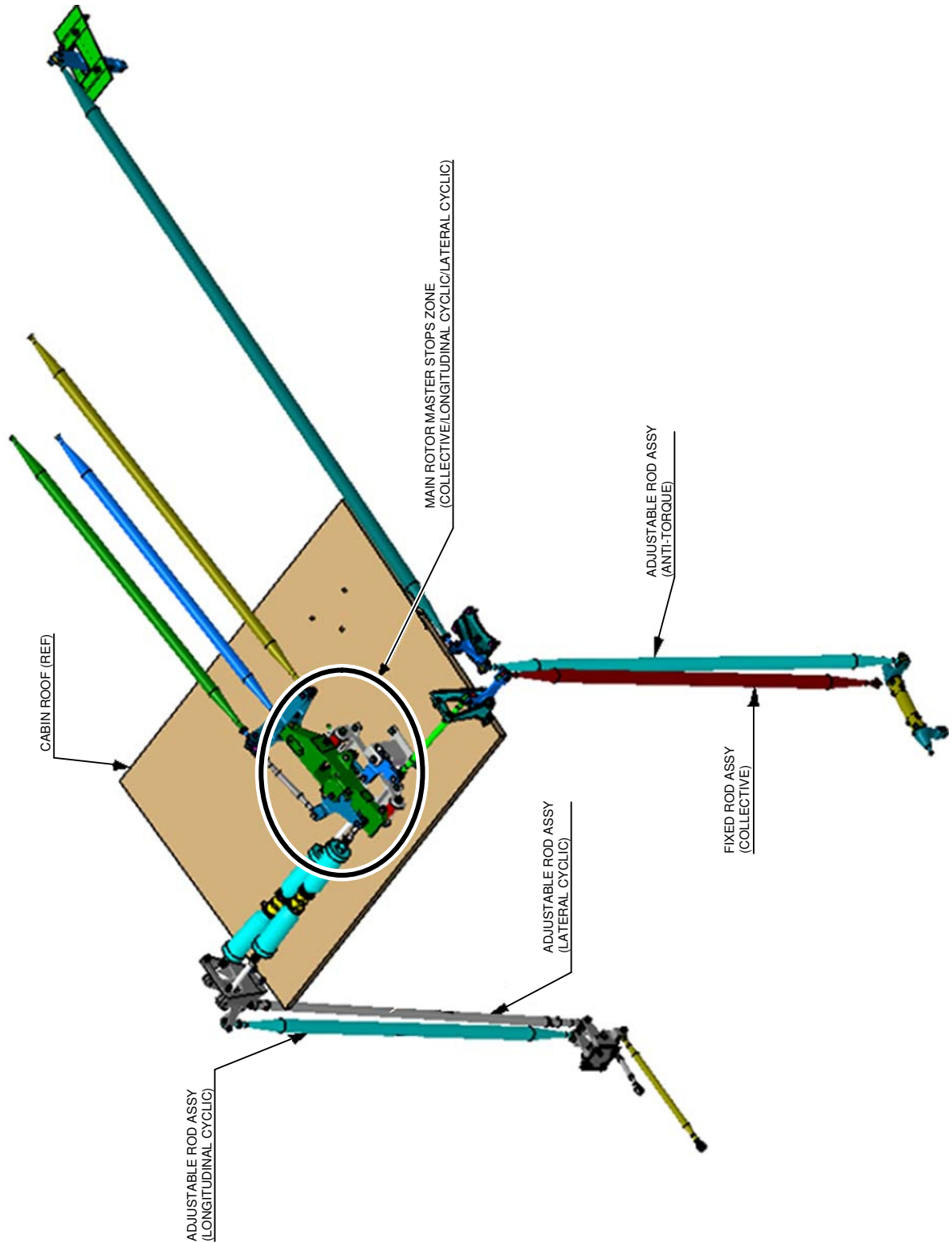

Figure 3

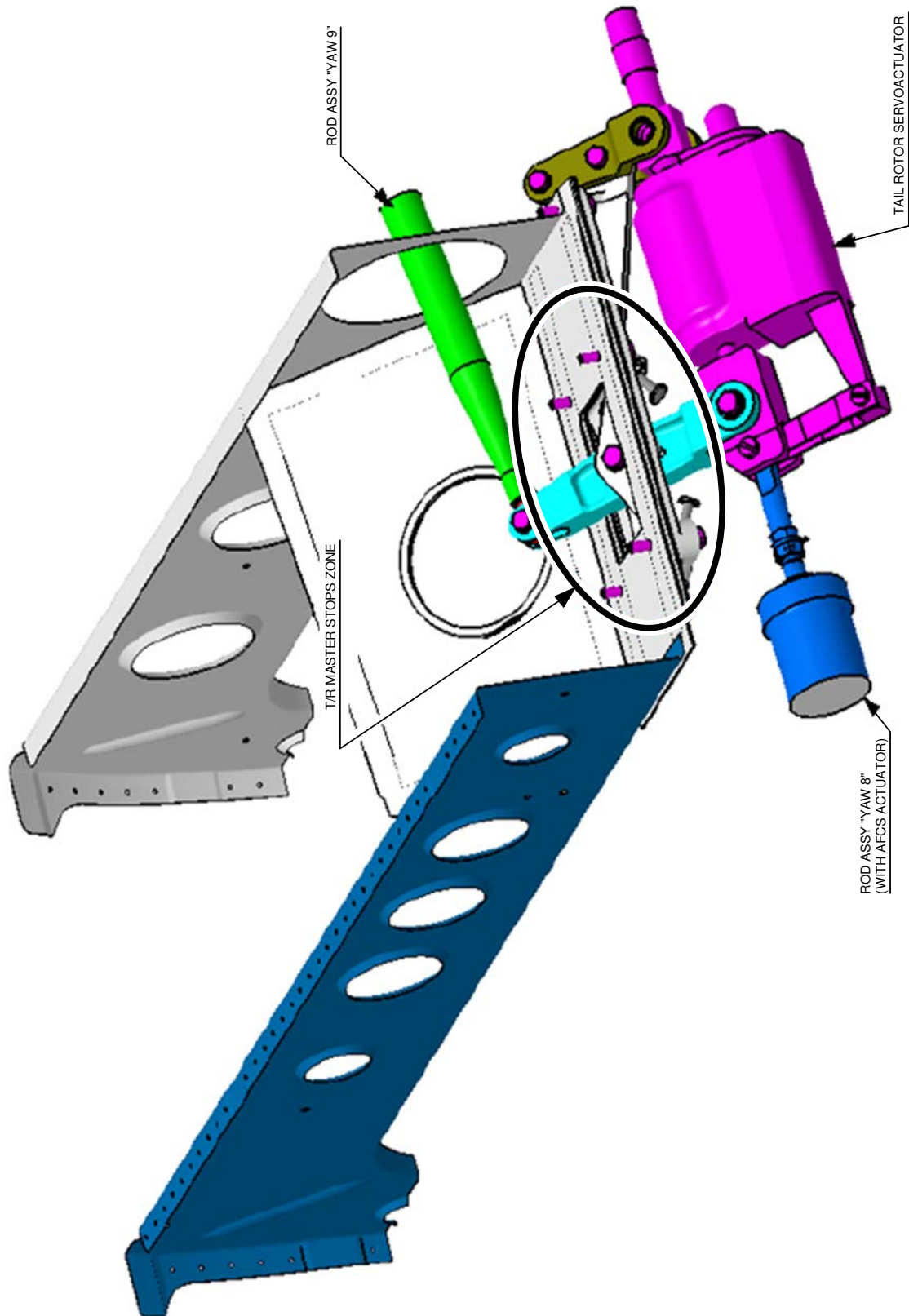

Figure 4

S.B. N°109EP-173 ALERT
DATE: November 10, 2020
REVISION: B - August 24, 2023

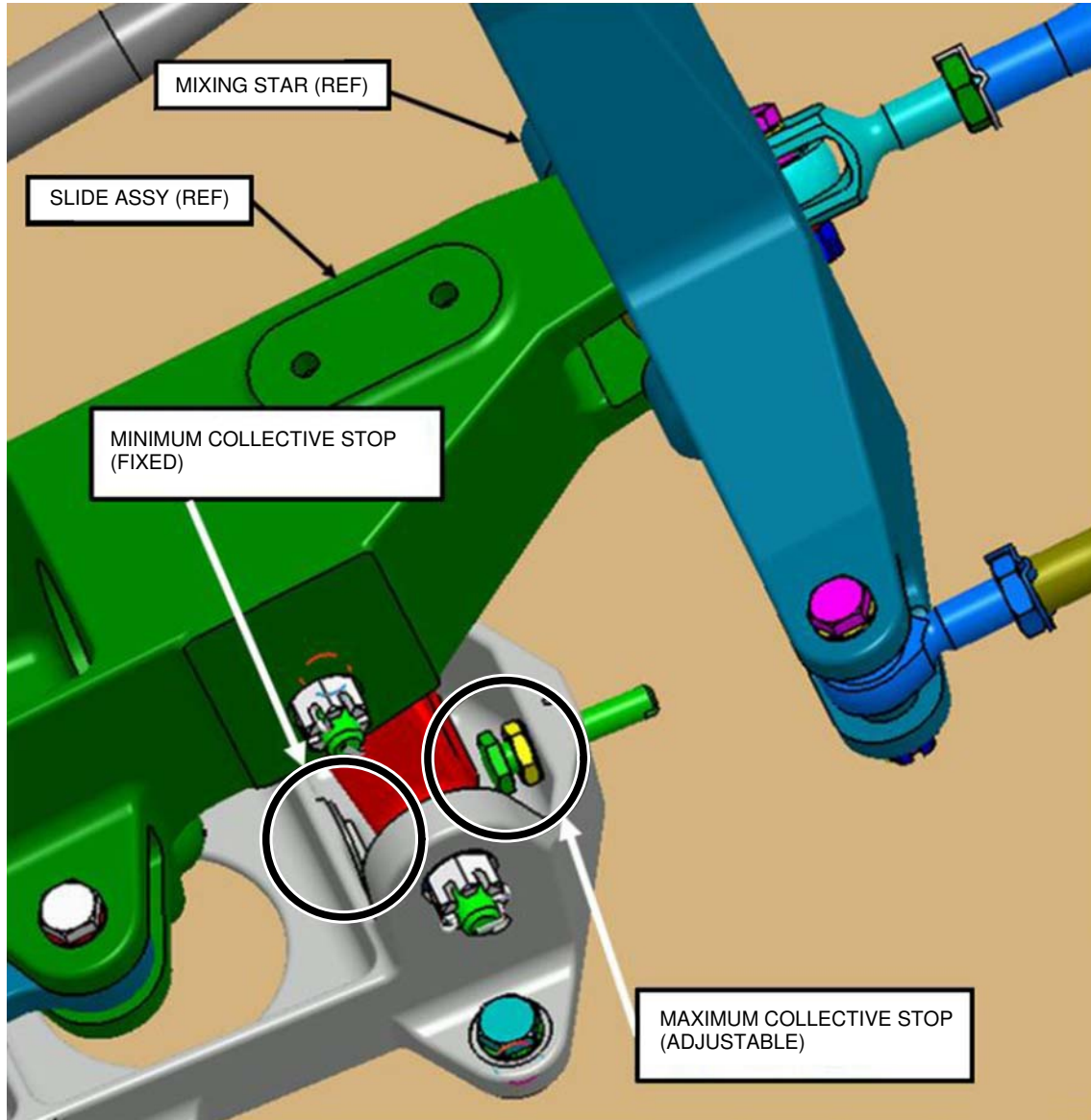

Figure 5

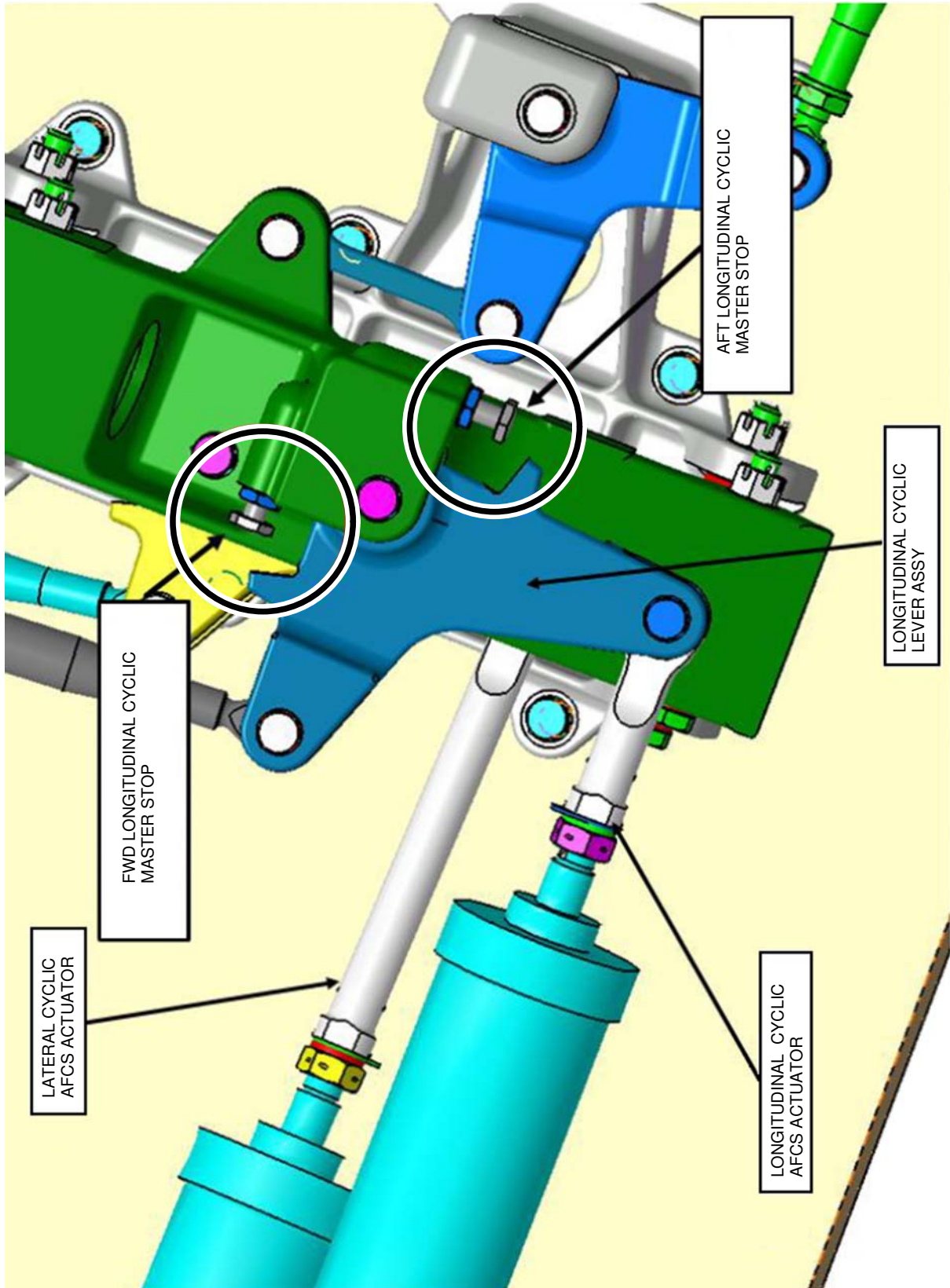

Figure 6

S.B. N°109EP-173 ALERT
DATE: November 10, 2020
REVISION: B - August 24, 2023

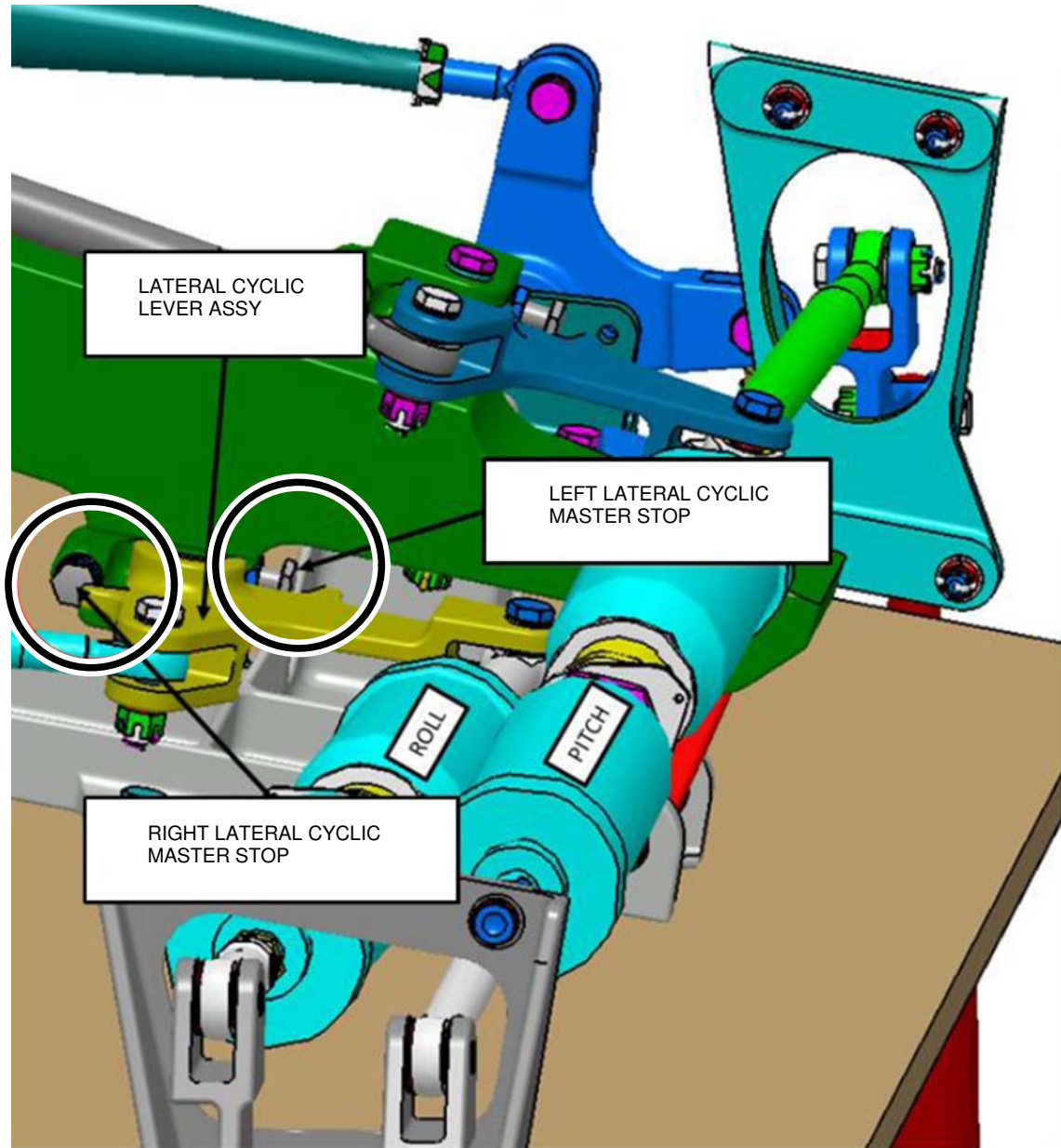

Figure 7

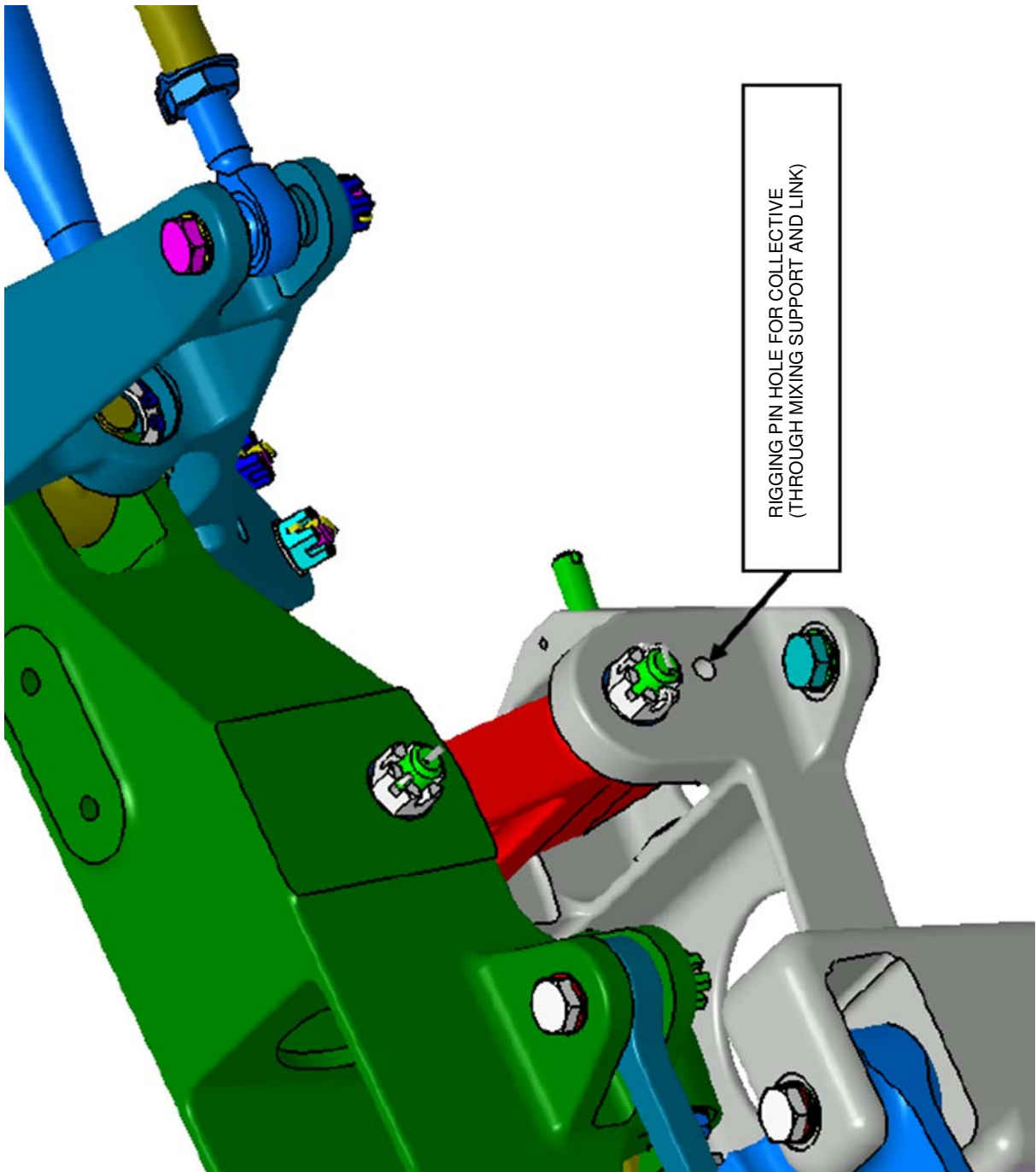

Figure 8

S.B. N°109EP-173 ALERT
DATE: November 10, 2020
REVISION: B - August 24, 2023

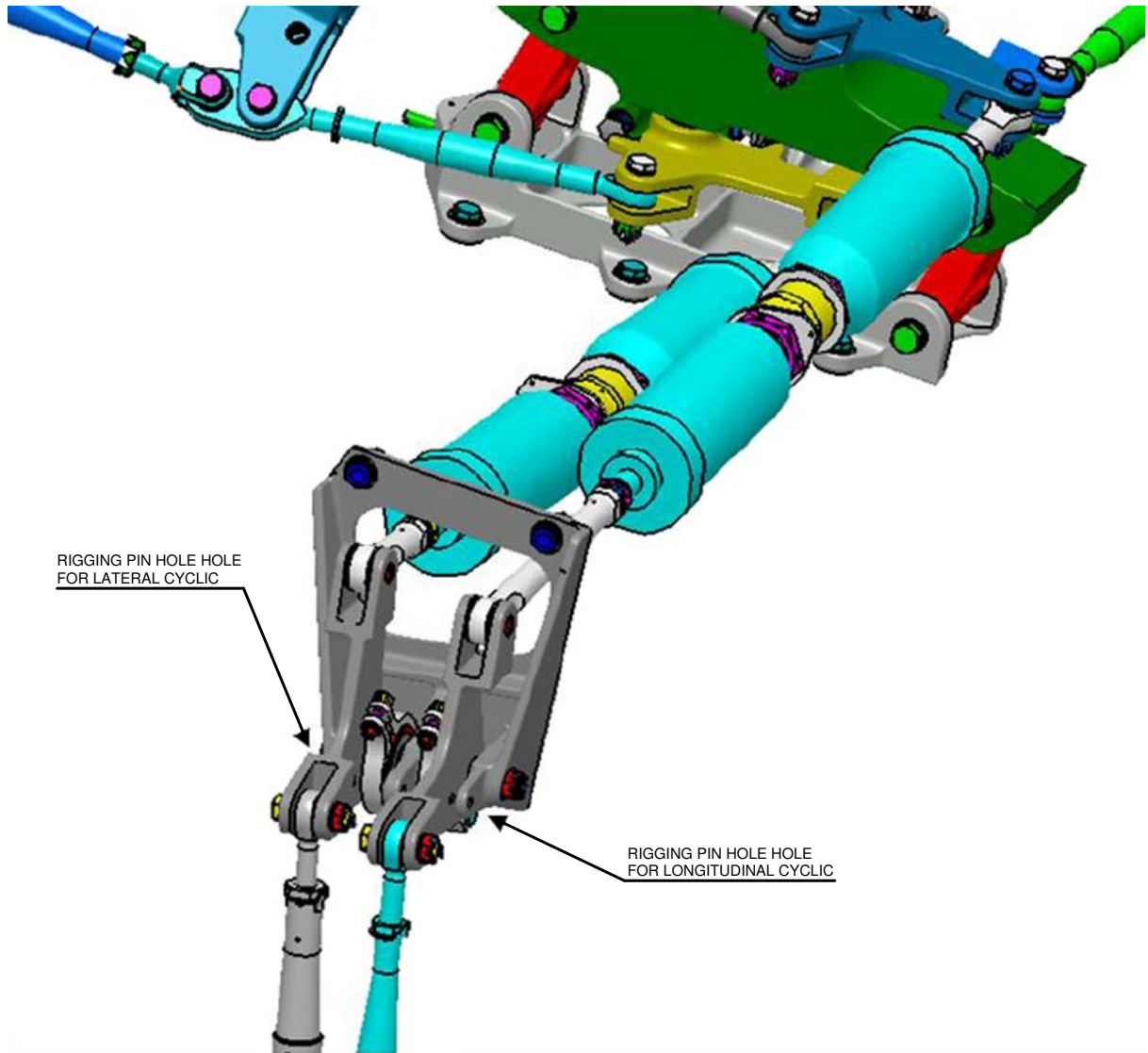

Figure 9

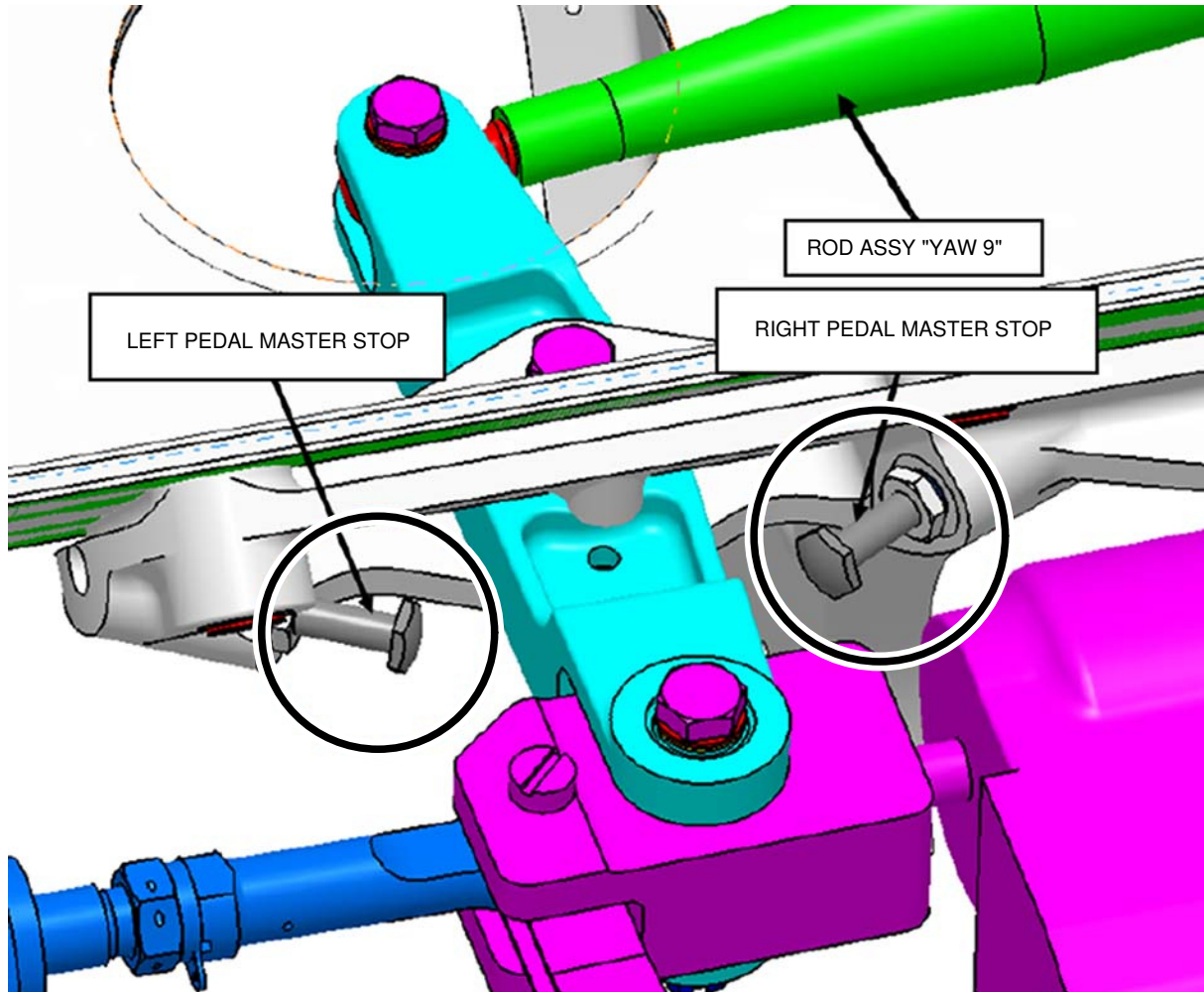

Figure 10

S.B. N°109EP-173 ALERT
DATE: November 10, 2020
REVISION: B - August 24, 2023

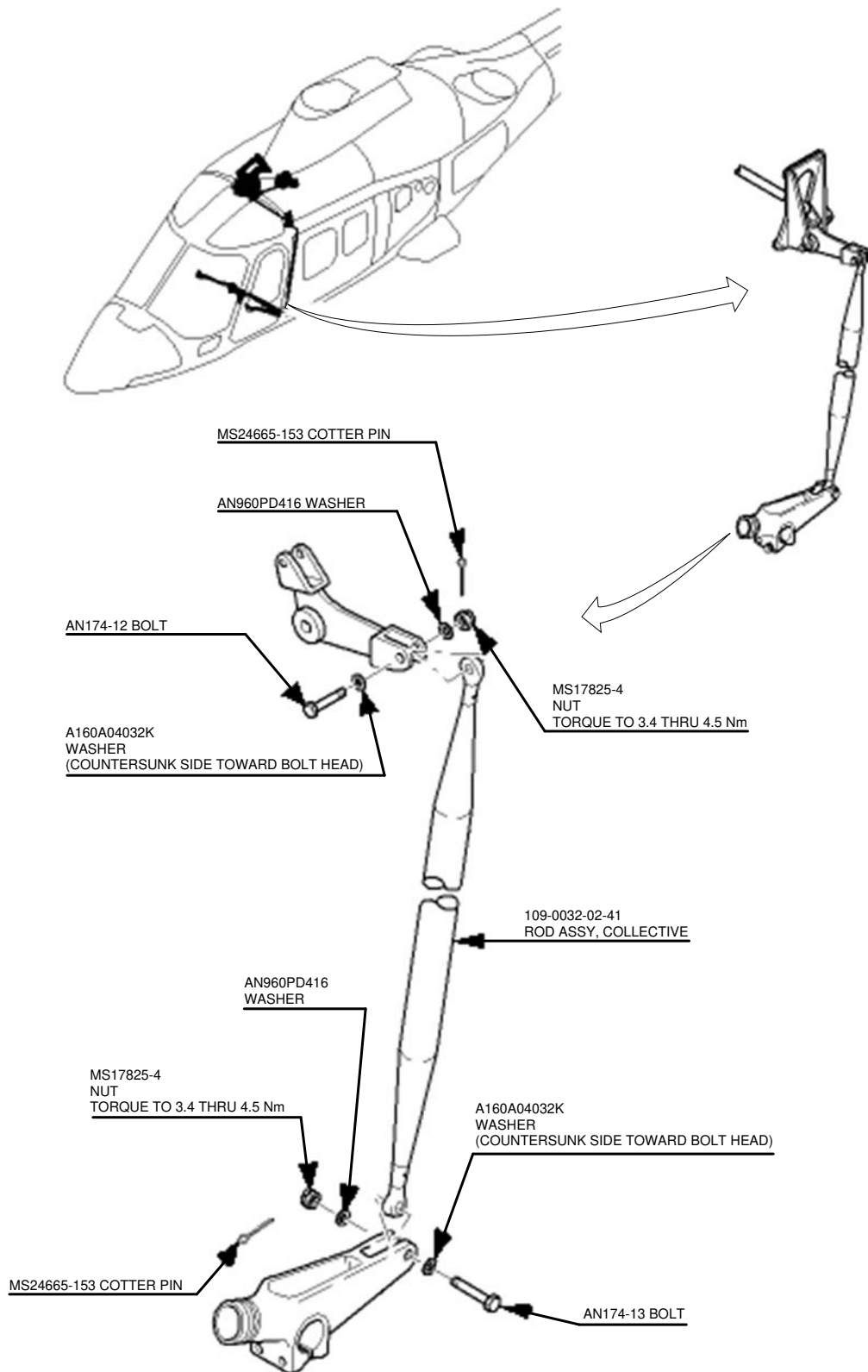

Figure 11

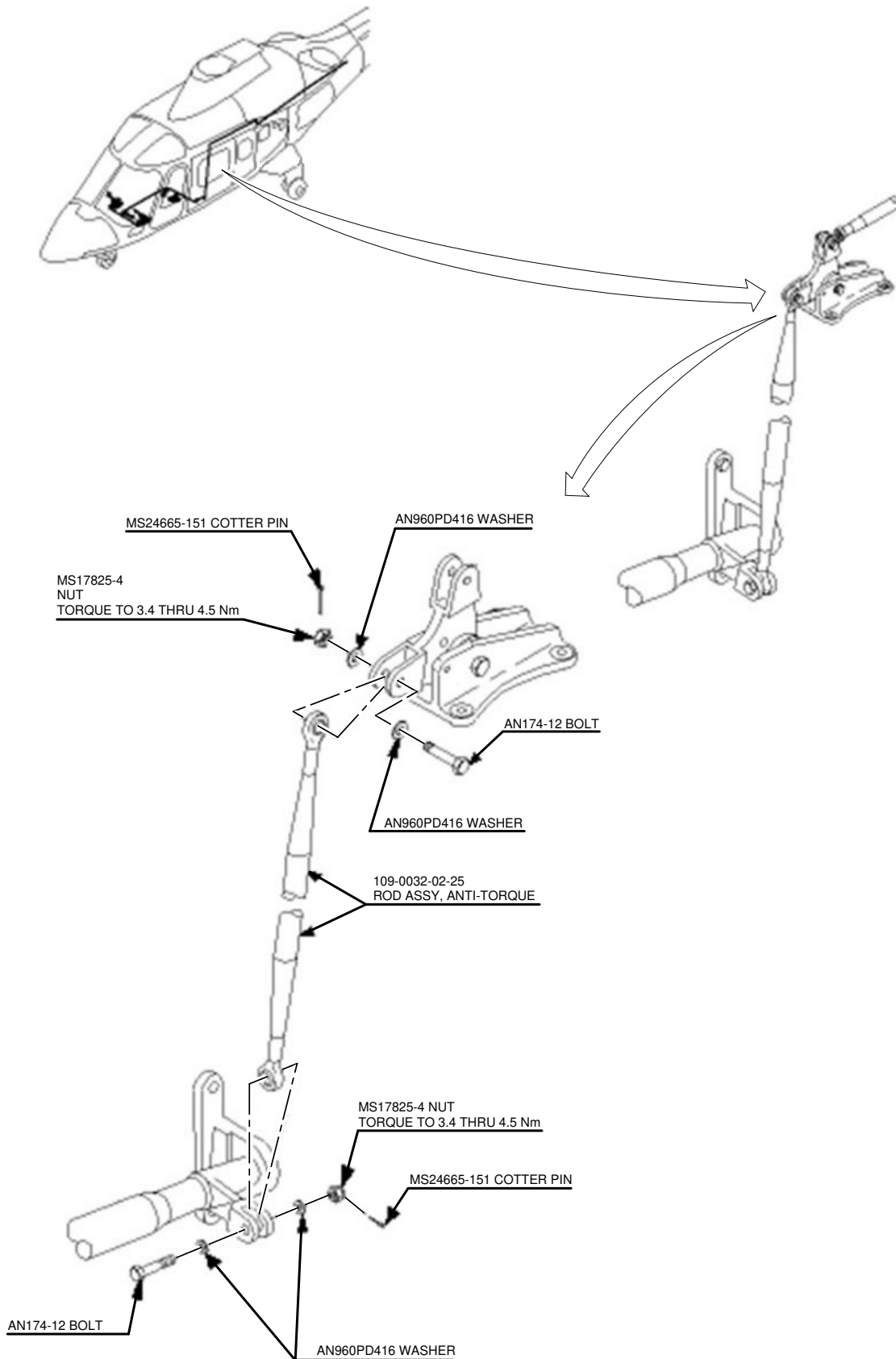

Figure 12

S.B. N°109EP-173 ALERT
DATE: November 10, 2020
REVISION: B - August 24, 2023

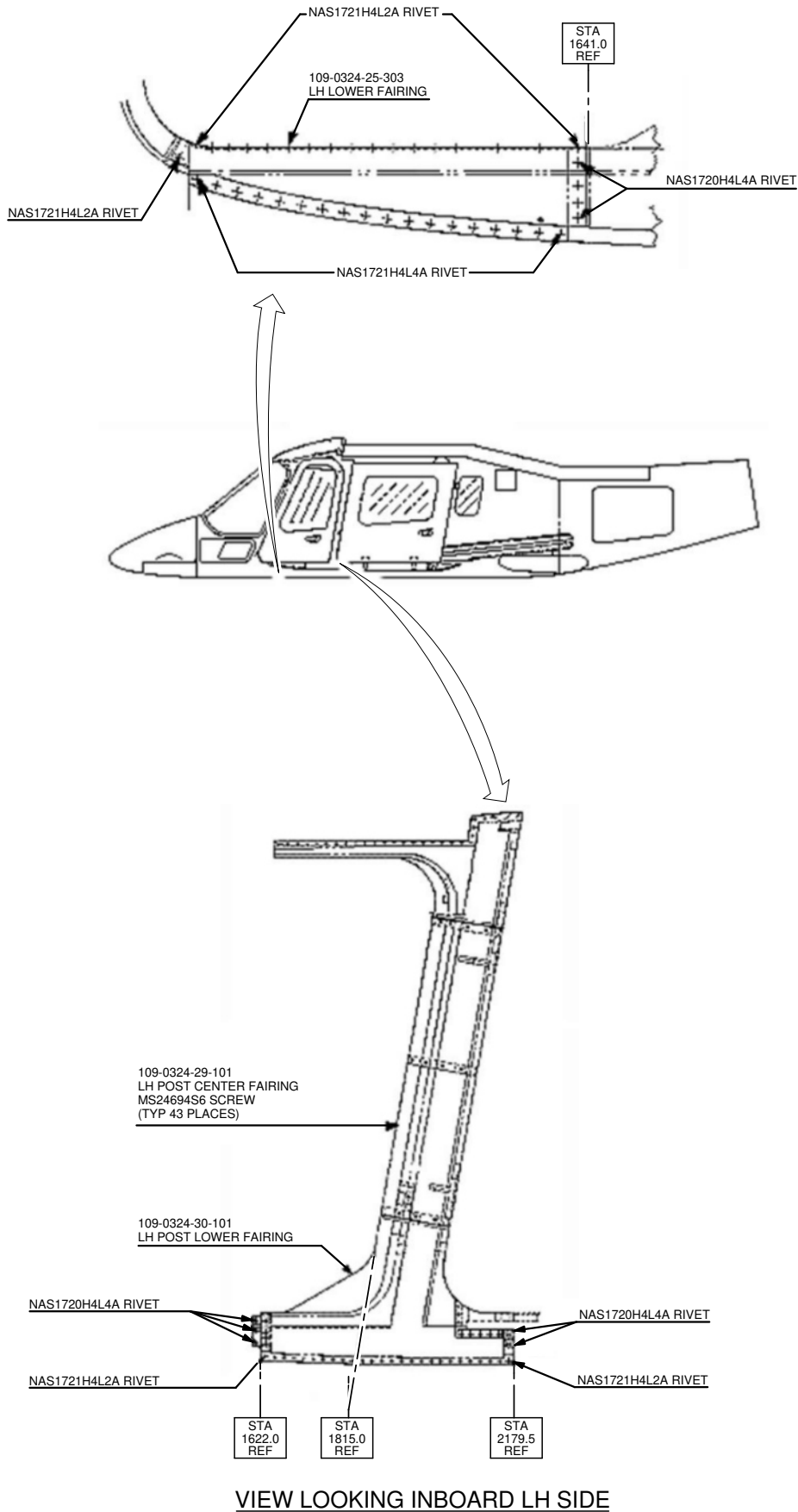

Figure 13

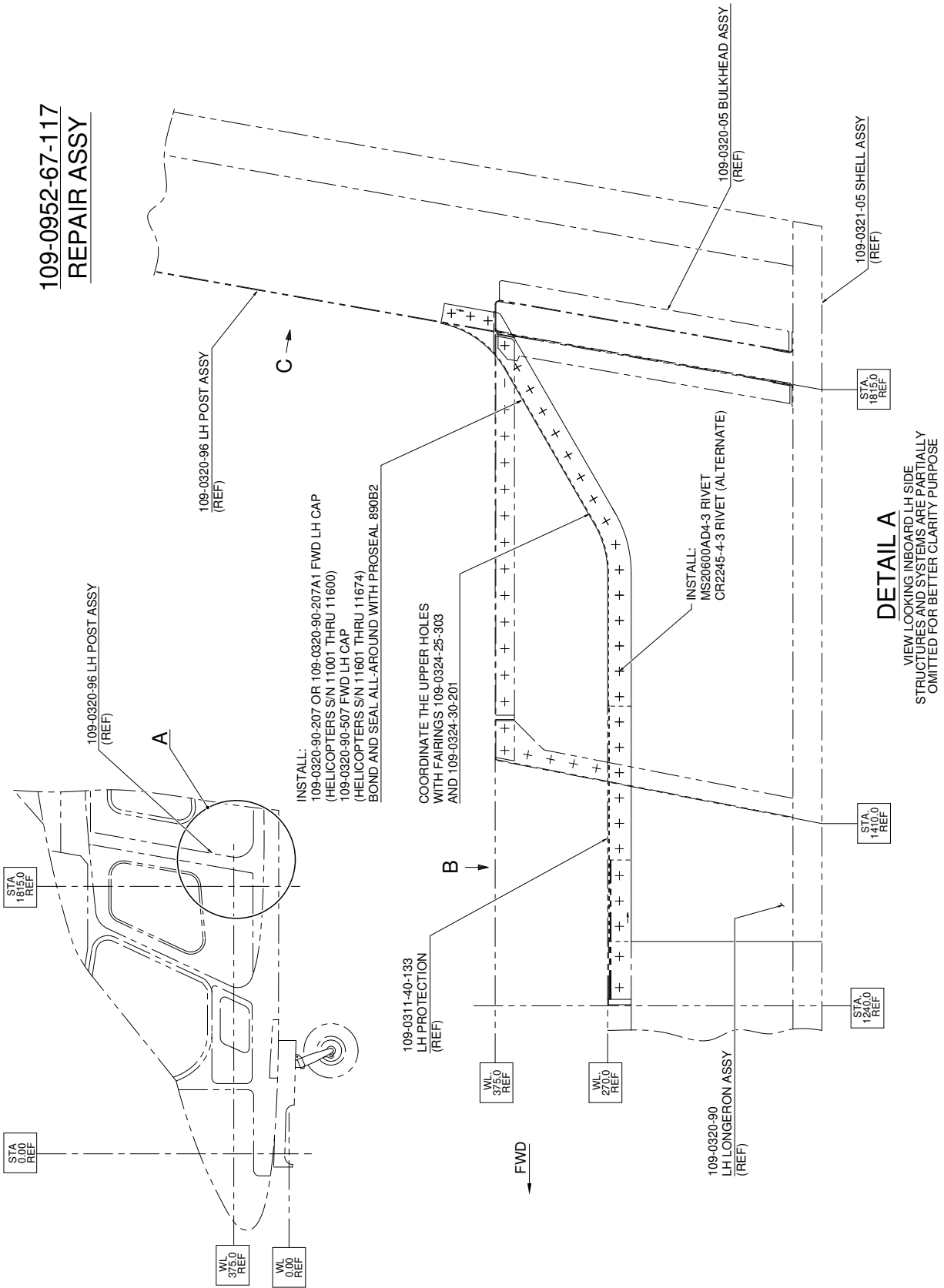
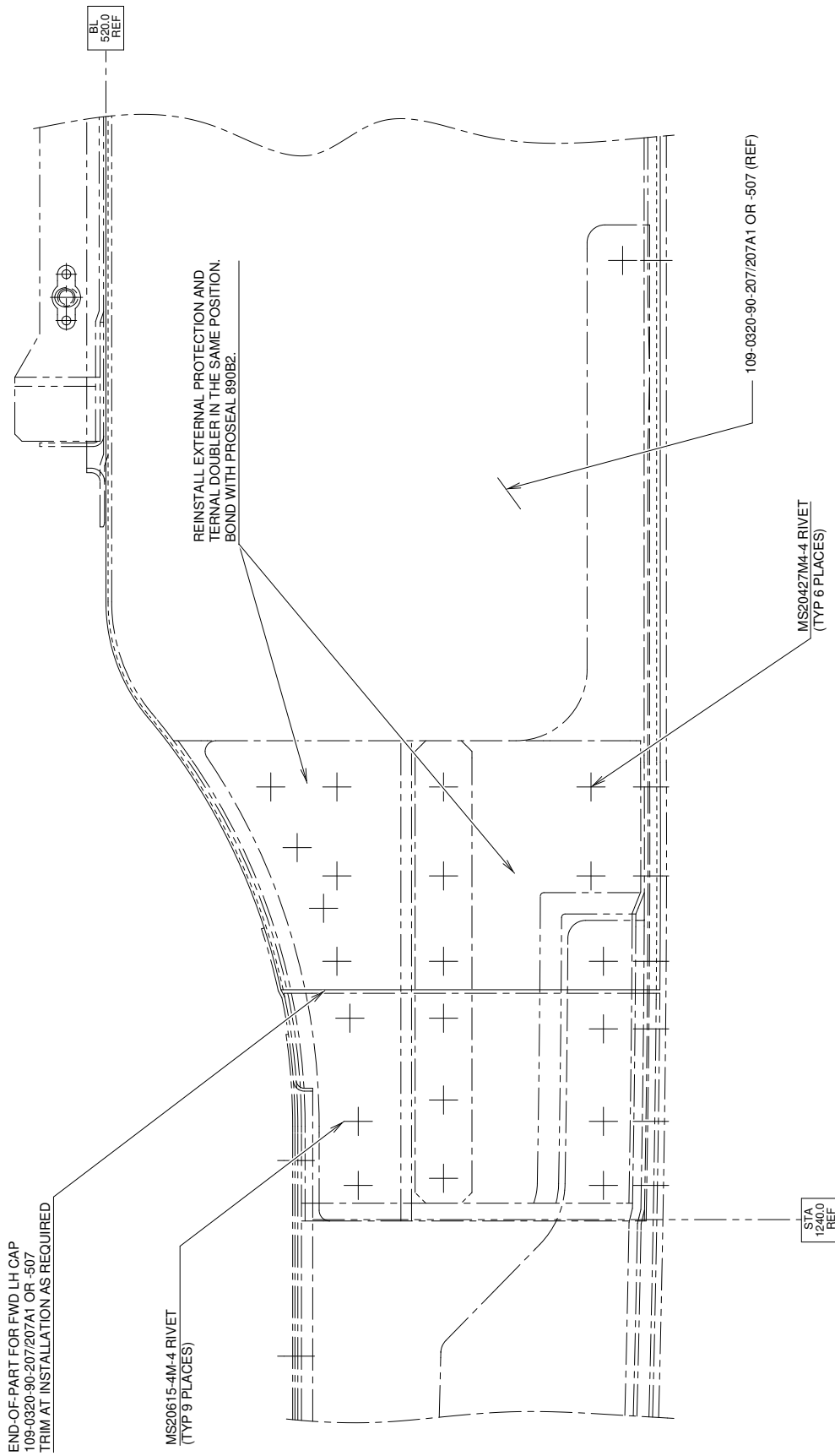

Figure 14

S.B. N°109EP-173 ALERT
DATE: November 10, 2020
REVISION: B - August 24, 2023



VIEW B

STRUCTURES AND SYSTEMS ARE PARTIALLY OMITTED FOR BETTER CLARITY PURPOSE

Figure 15

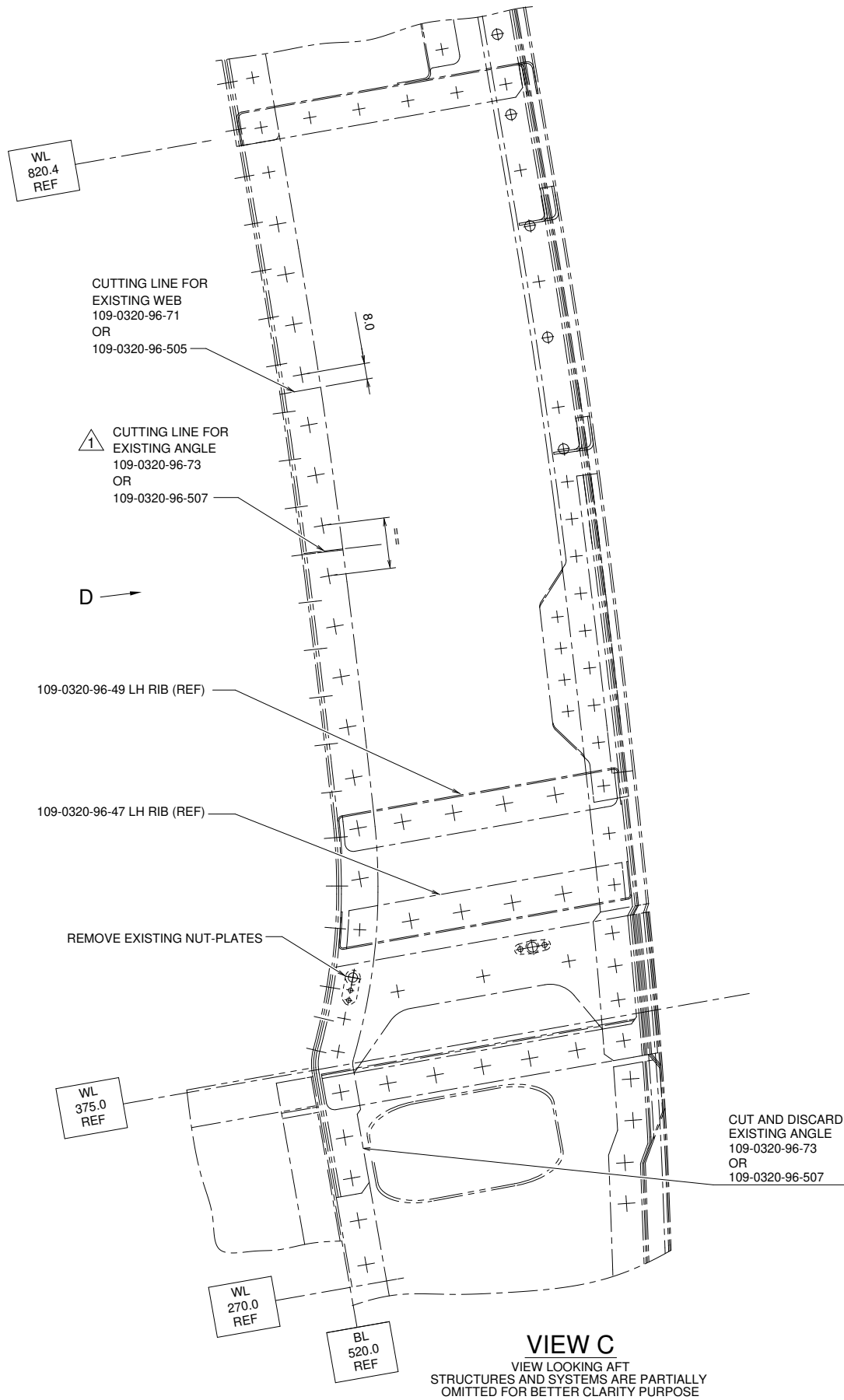
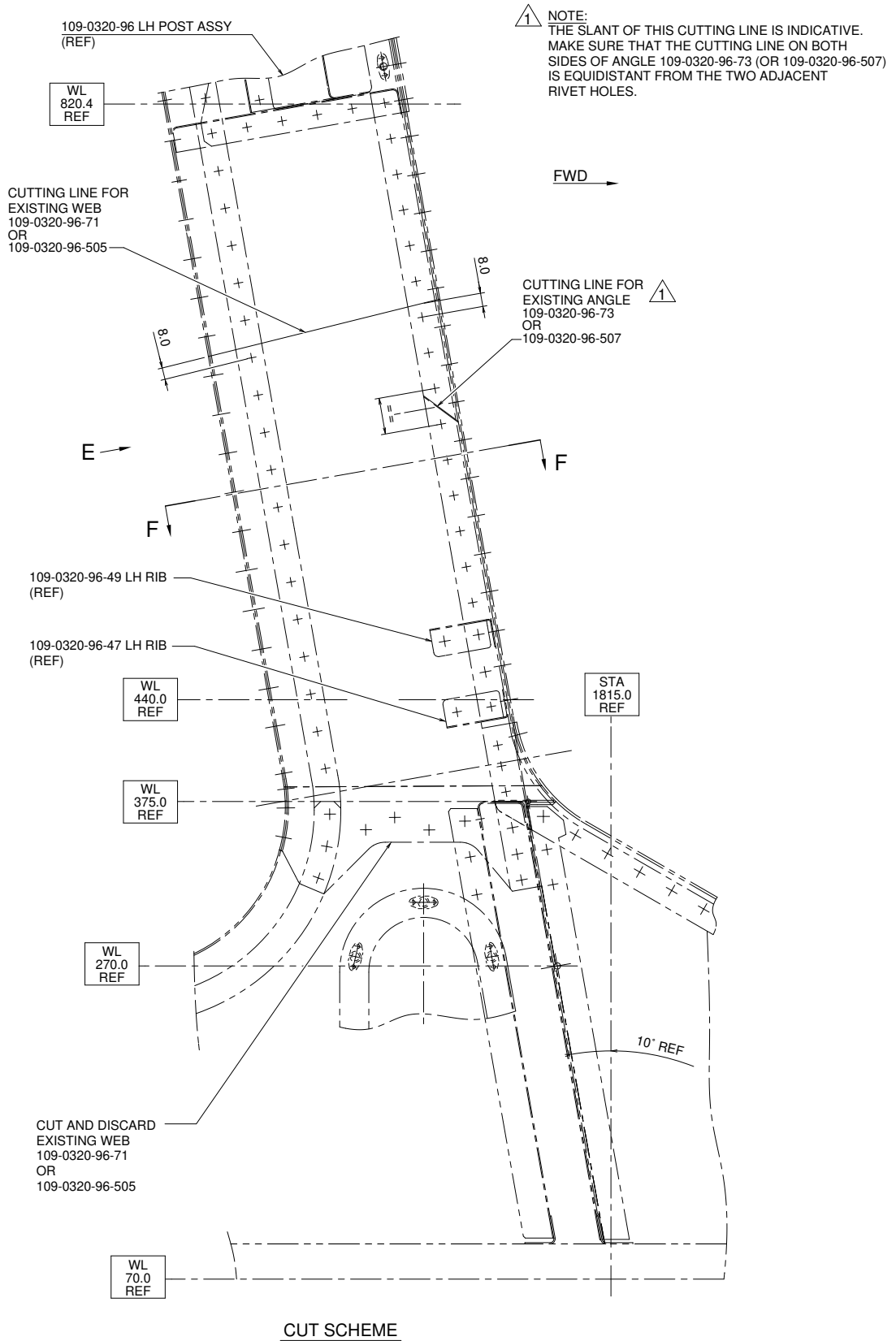

Figure 16

S.B. N°109EP-173 ALERT
DATE: November 10, 2020
REVISION: B - August 24, 2023



VIEW D

VIEW LOOKING OUTBOARD LH SIDE
STRUCTURES AND SYSTEMS ARE PARTIALLY
OMITTED FOR BETTER CLARITY PURPOSE

Figure 17

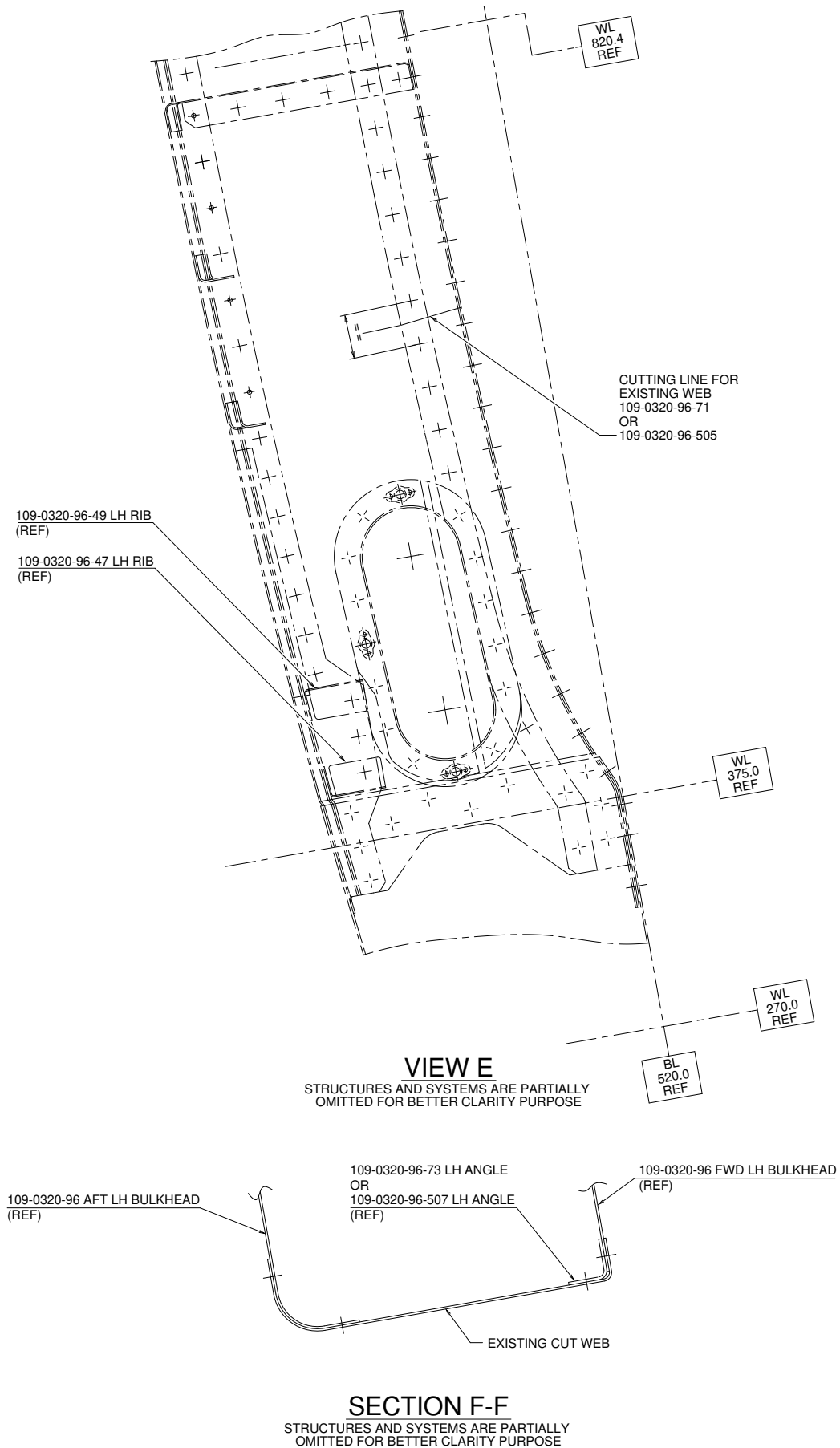
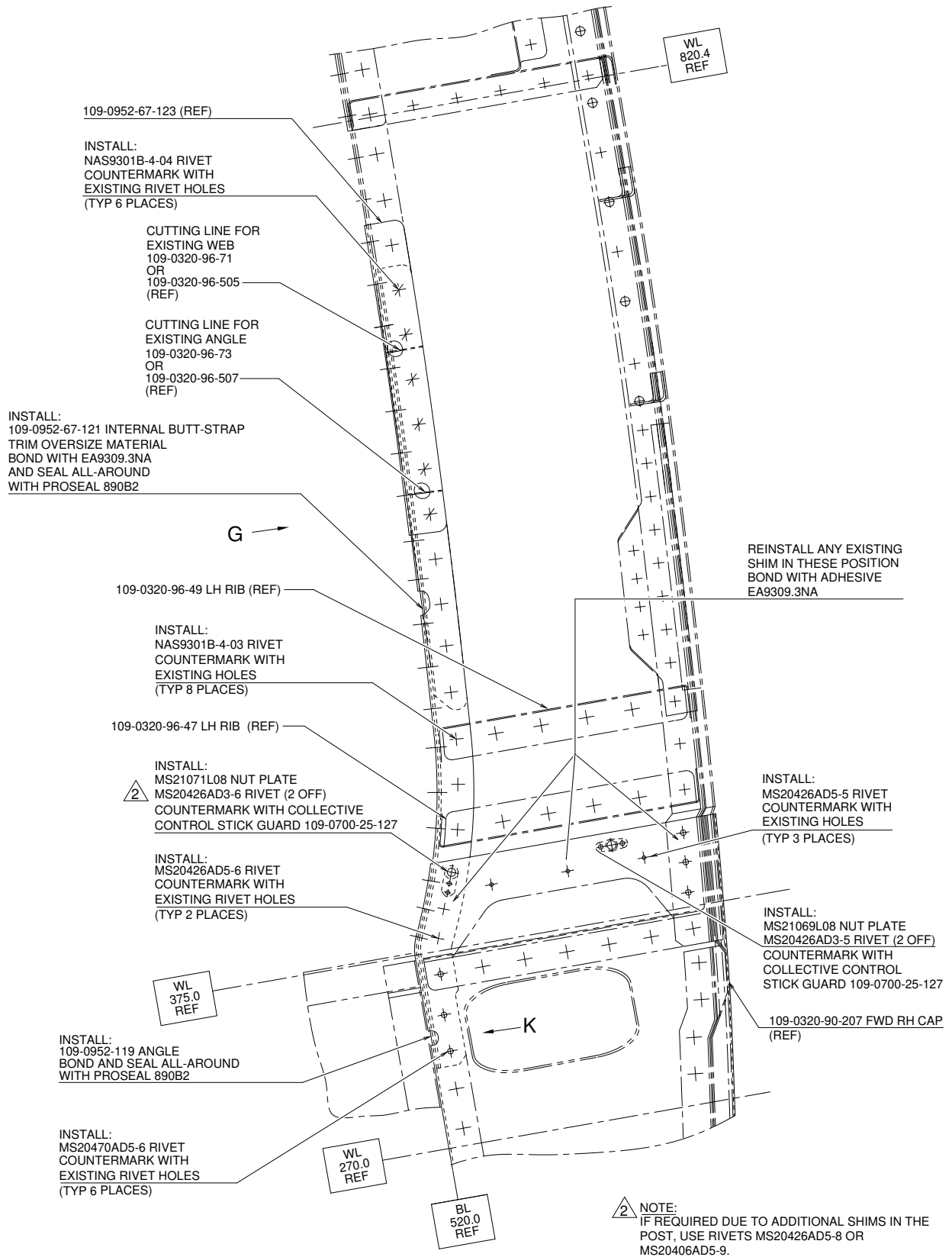

Figure 18

S.B. N°109EP-173 ALERT
DATE: November 10, 2020
REVISION: B - August 24, 2023



VIEW C

STRUCTURES AND SYSTEMS ARE PARTIALLY
OMITTED FOR BETTER CLARITY PURPOSE

Figure 19

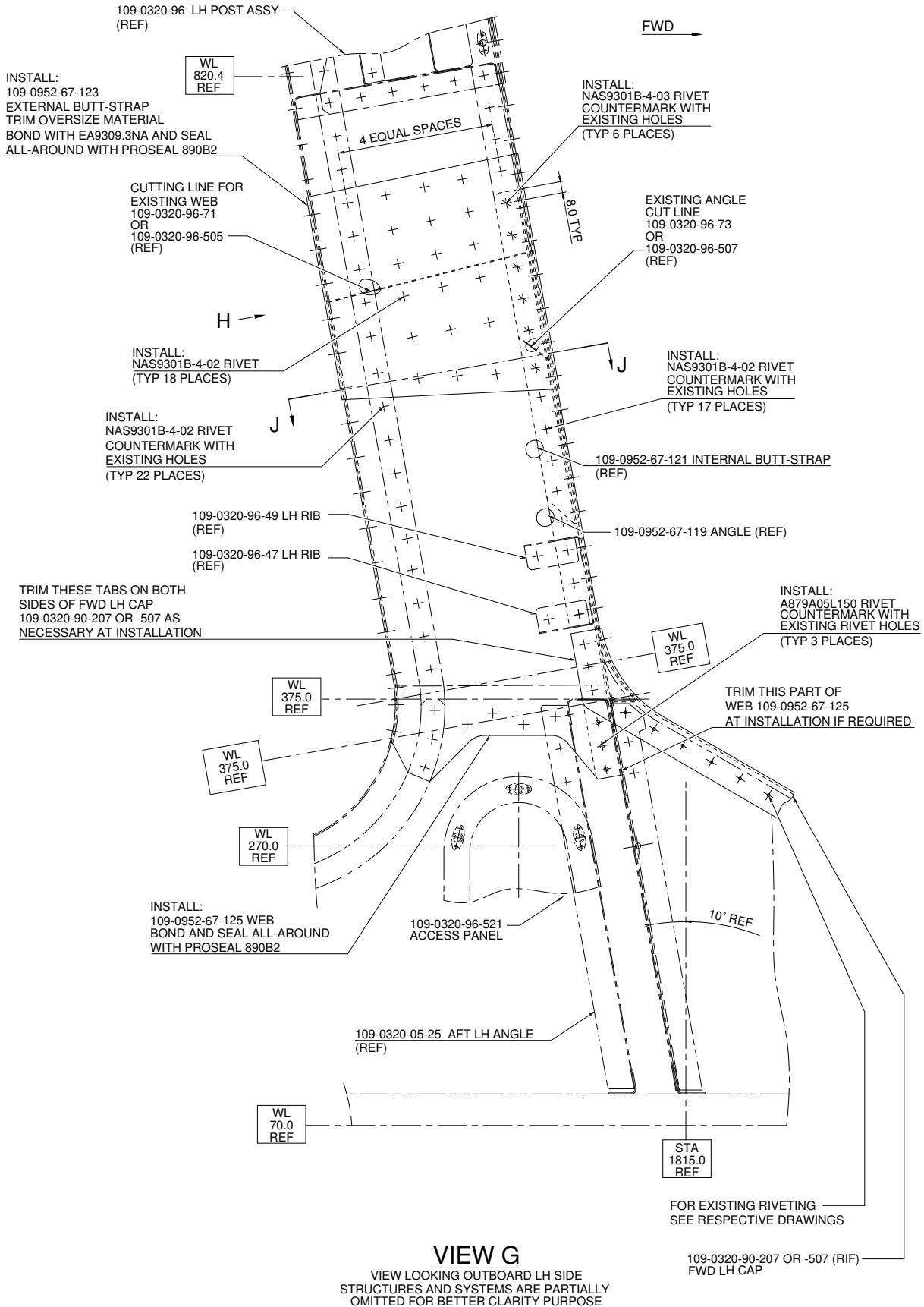

Figure 20

S.B. N°109EP-173 ALERT
DATE: November 10, 2020
REVISION: B - August 24, 2023

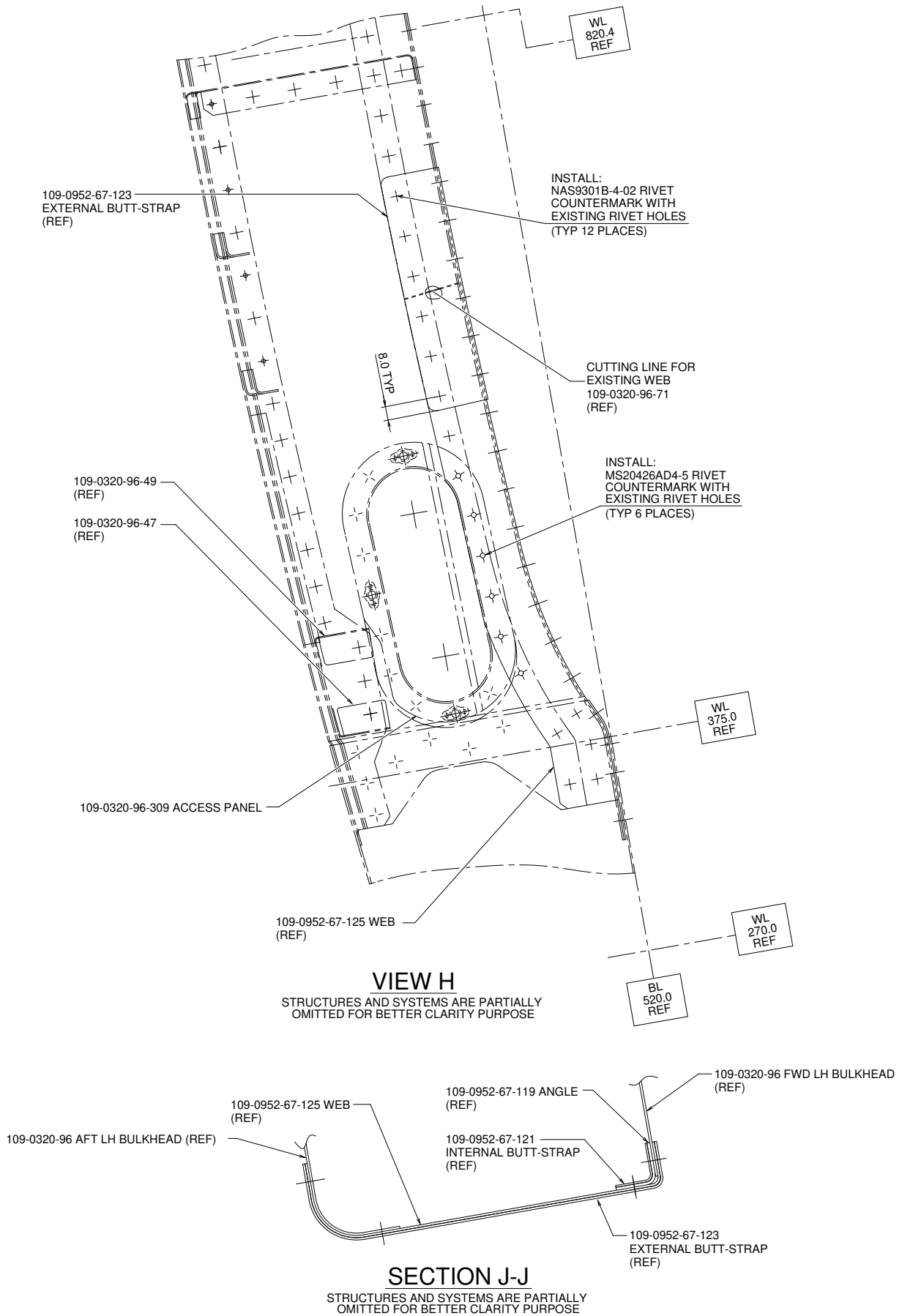
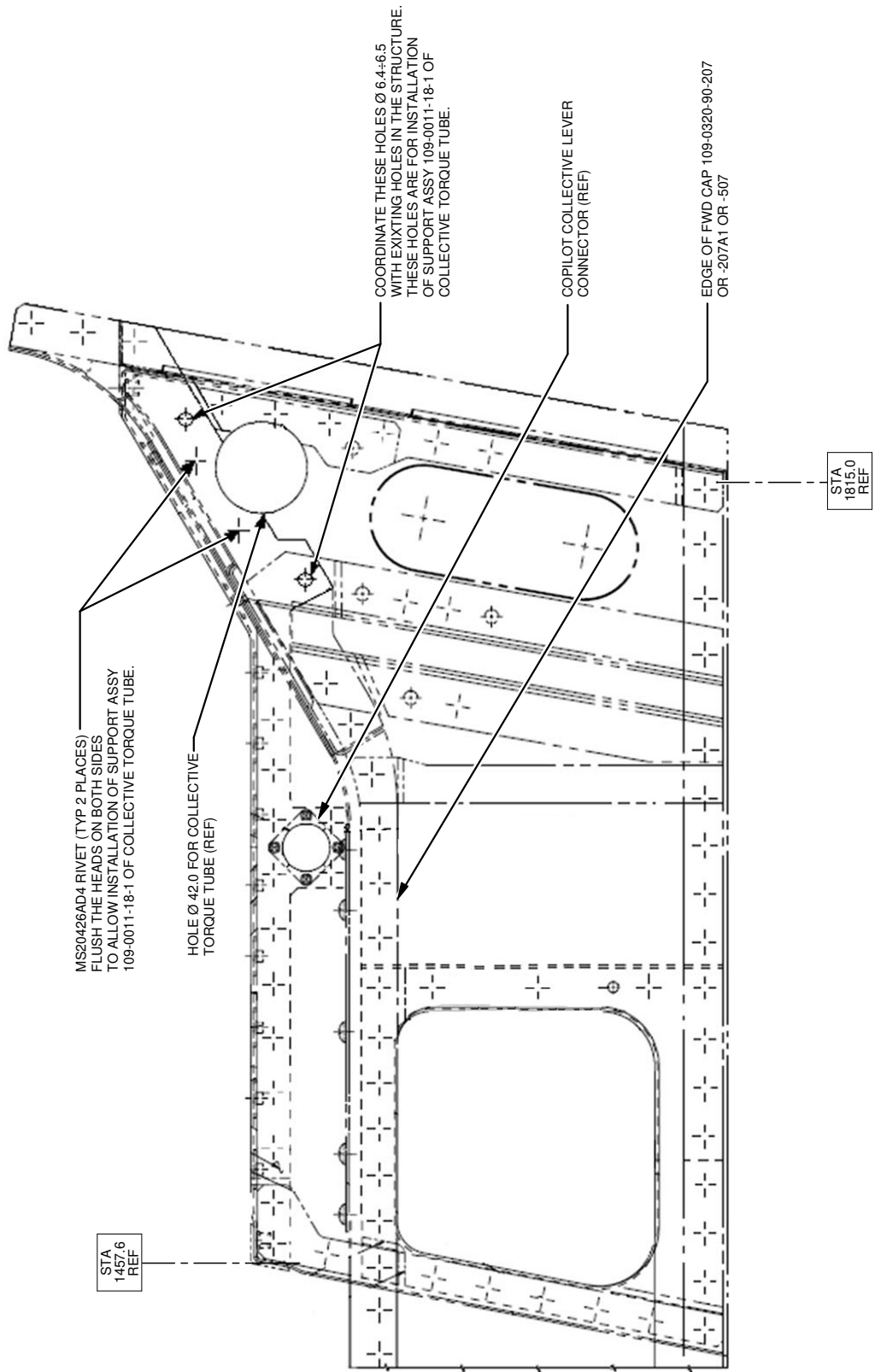

Figure 21



VIEW K
VIEW LOOKING INBOARD LH SIDE
STRUCTURES AND SYSTEMS ARE PARTIALLY
OMITTED FOR BETTER CLARITY PURPOSE

Figure 22

S.B. N°109EP-173 ALERT
DATE: November 10, 2020
REVISION: B - August 24, 2023

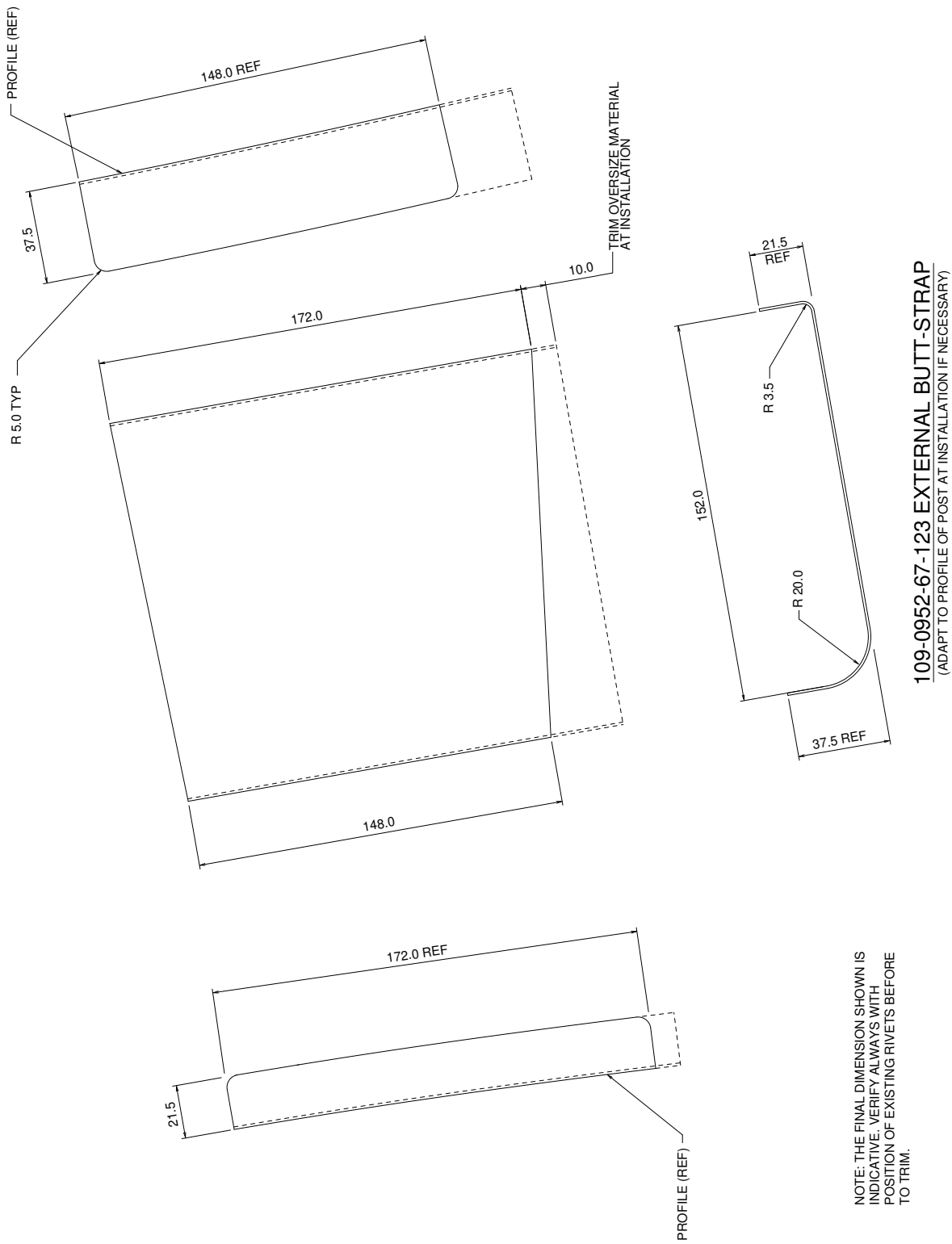
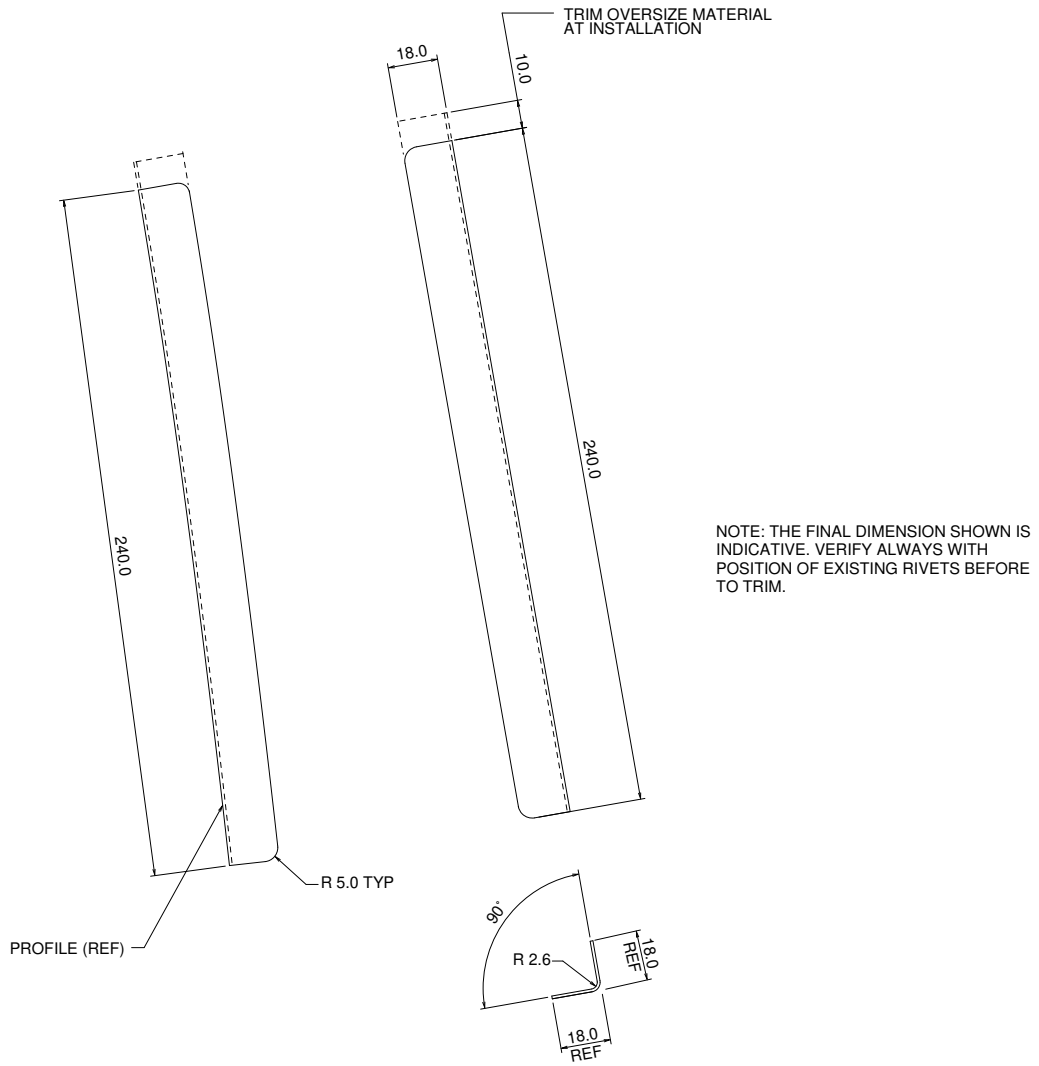
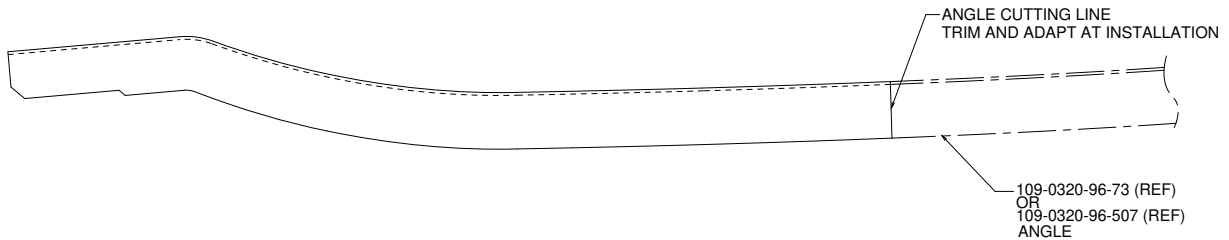

Figure 23



109-0952-67-121 INTERNAL BUTT-STRAP
(ADAPT TO PROFILE OF POST AT INSTALLATION IF NECESSARY)



109-0952-67-119 ANGLE
(REWORK FROM ANGLE)

Figure 24

S.B. N°109EP-173 ALERT
DATE: November 10, 2020
REVISION: B - August 24, 2023

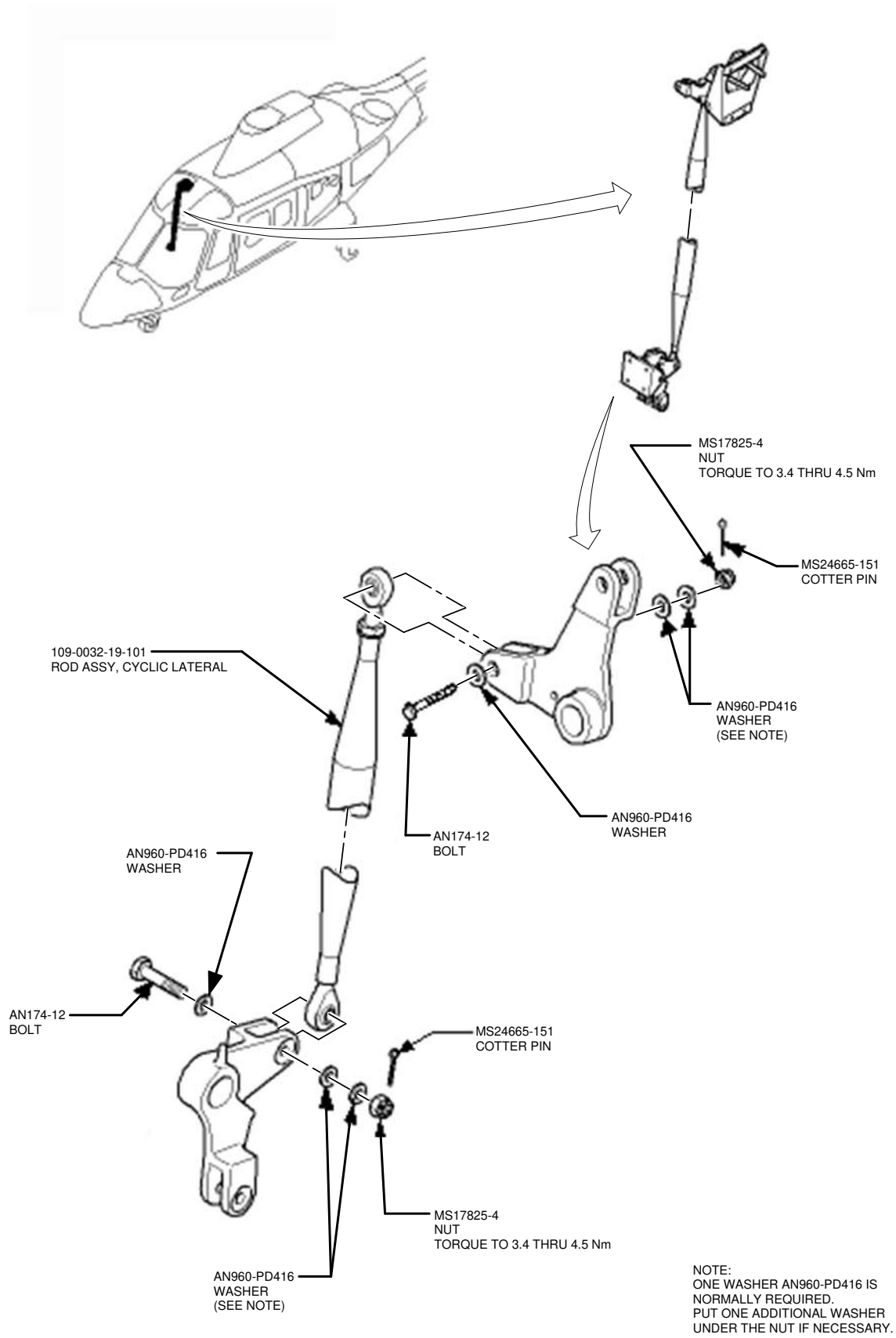

Figure 25

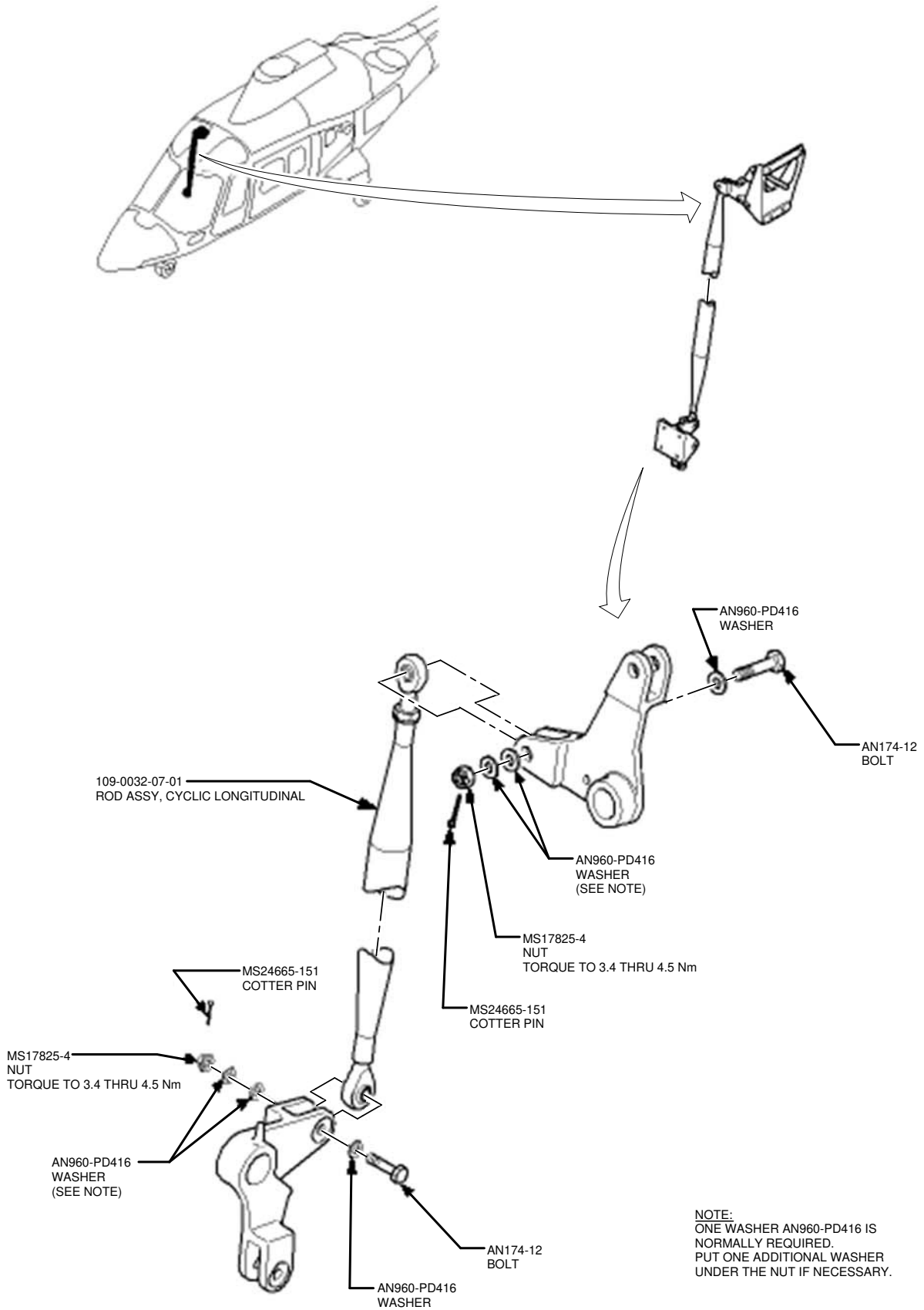
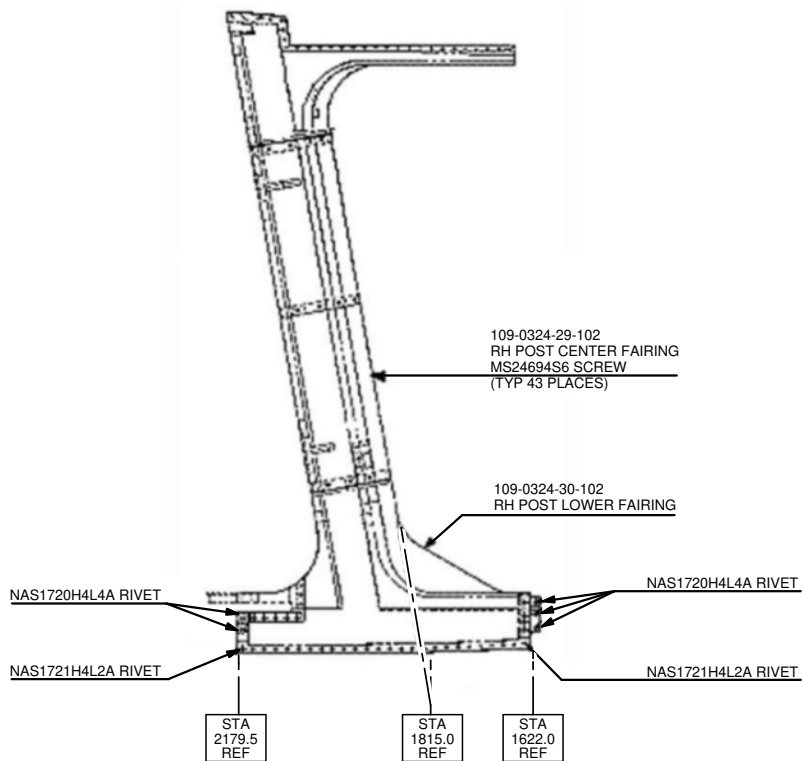
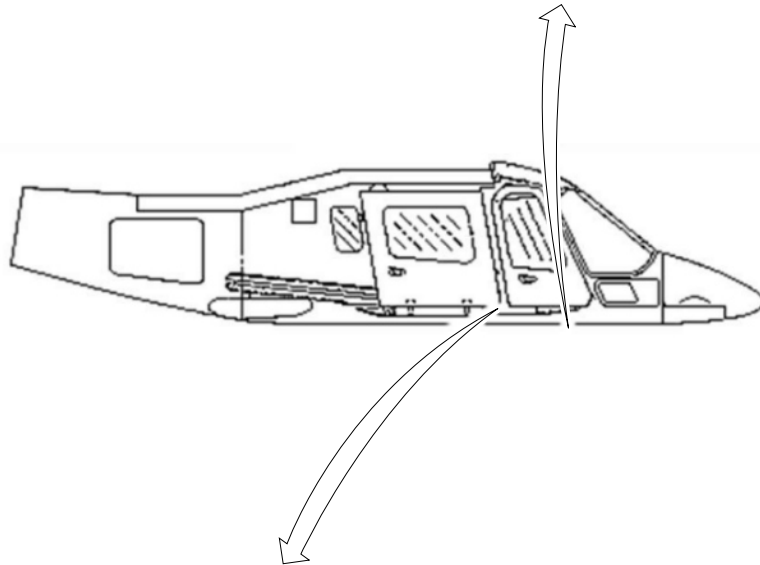
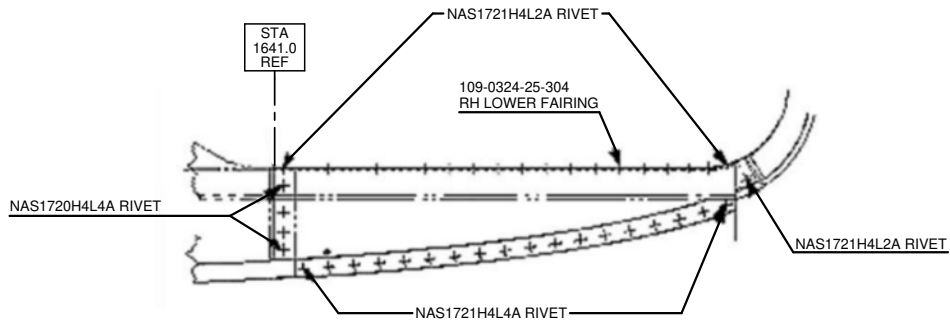

Figure 26

S.B. N°109EP-173 ALERT
DATE: November 10, 2020
REVISION: B - August 24, 2023



VIEW LOOKING INBOARD RH SIDE

Figure 27

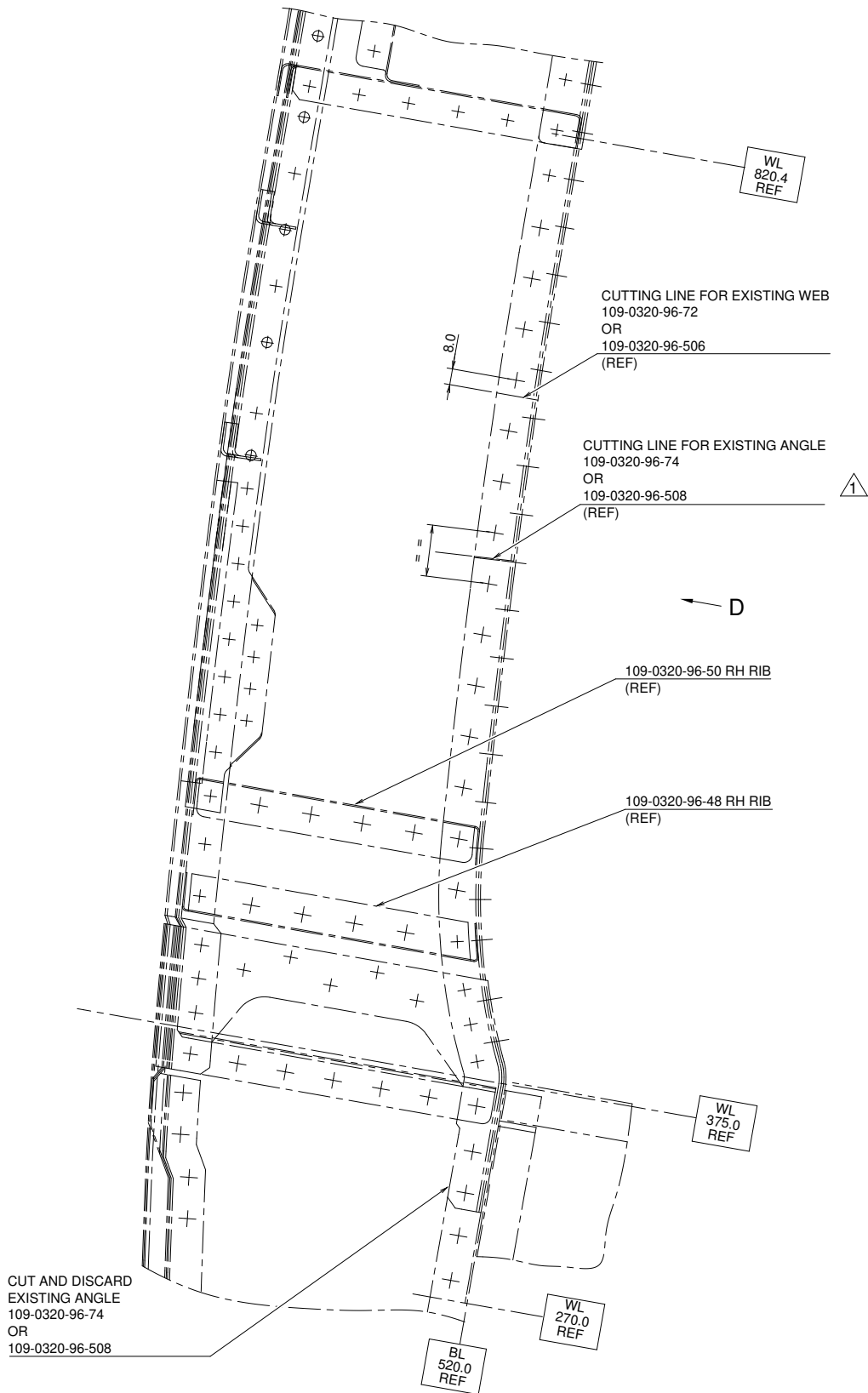

VIEW C

STRUCTURES AND SYSTEMS ARE PARTIALLY
OMITTED FOR BETTER CLARITY PURPOSE

Figure 29

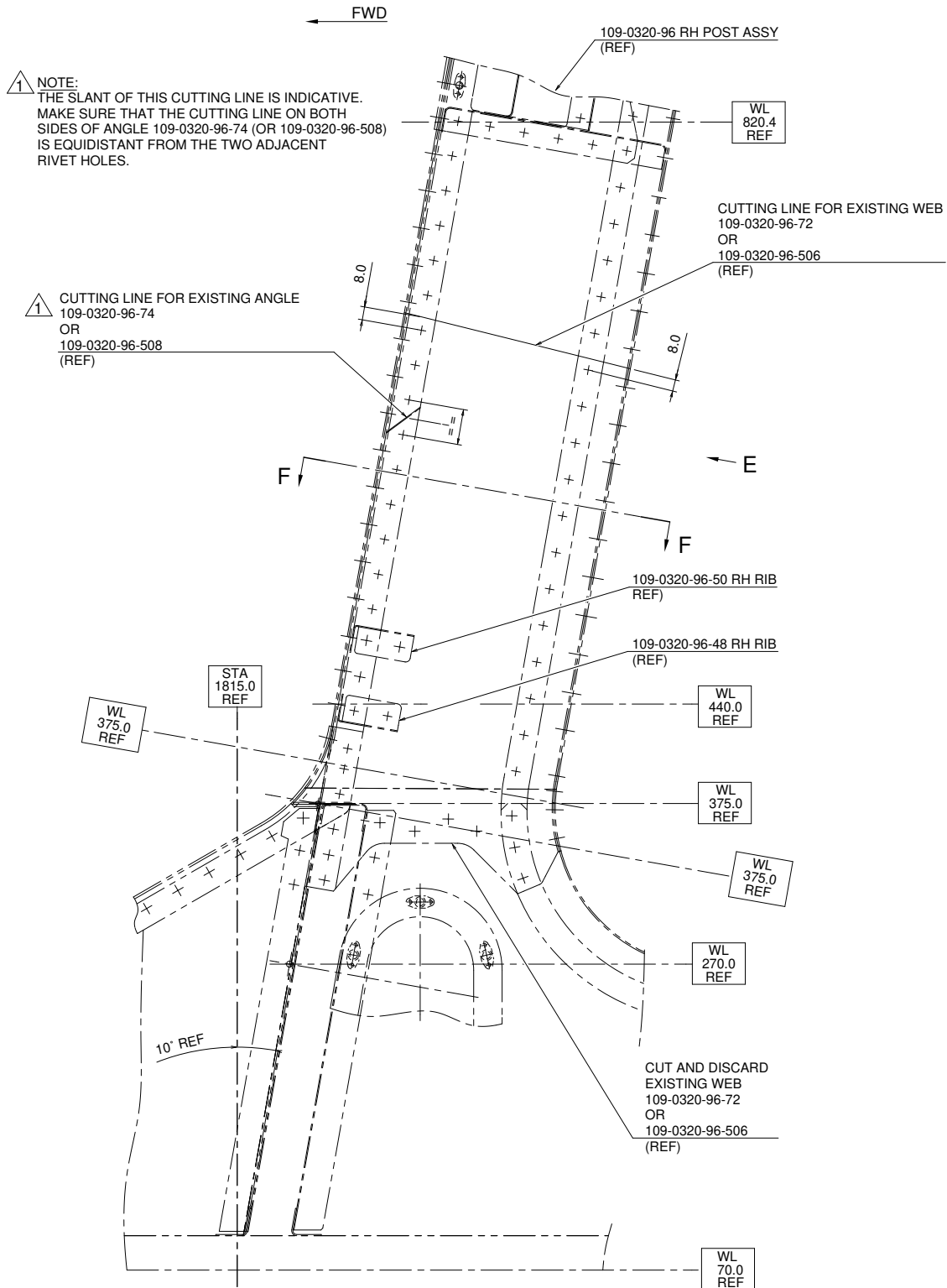

VIEW D

VIEW LOOKING OUTBOARD RH SIDE
STRUCTURES AND SYSTEMS ARE PARTIALLY
OMITTED FOR BETTER CLARITY PURPOSE

Figure 30

S.B. N°109EP-173 ALERT
DATE: November 10, 2020
REVISION: B - August 24, 2023

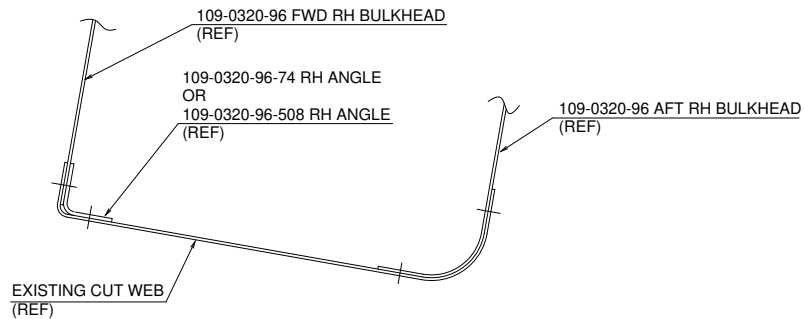
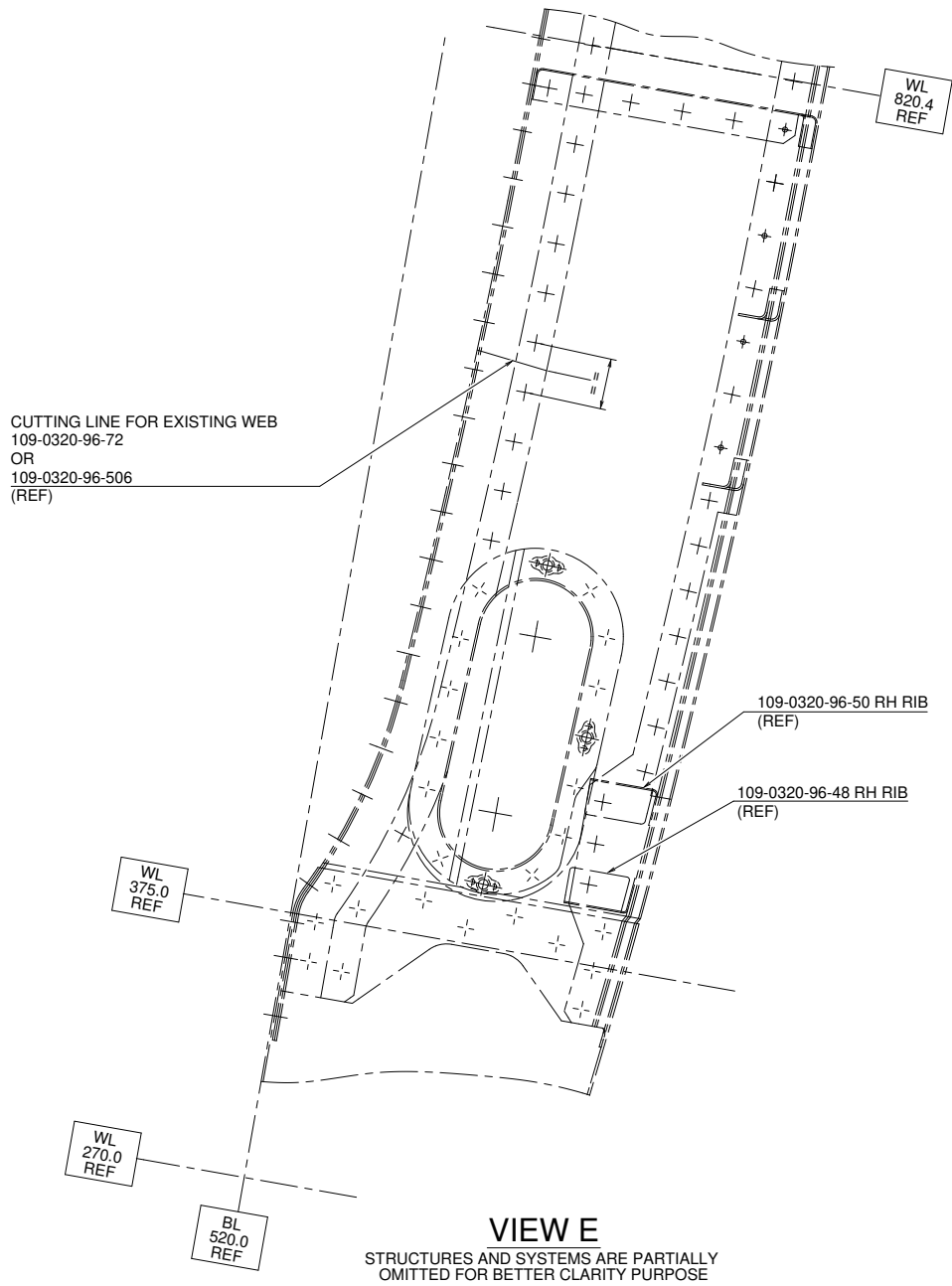

SECTION F-F

STRUCTURES AND SYSTEMS ARE PARTIALLY
OMITTED FOR BETTER CLARITY PURPOSE

Figure 31

NOTE:
IF REQUIRED DUE TO
ADDITIONAL SHIMS IN THE POST,
USE RIVETS MS20426AD5-8 OR
MS20406AD5-9.

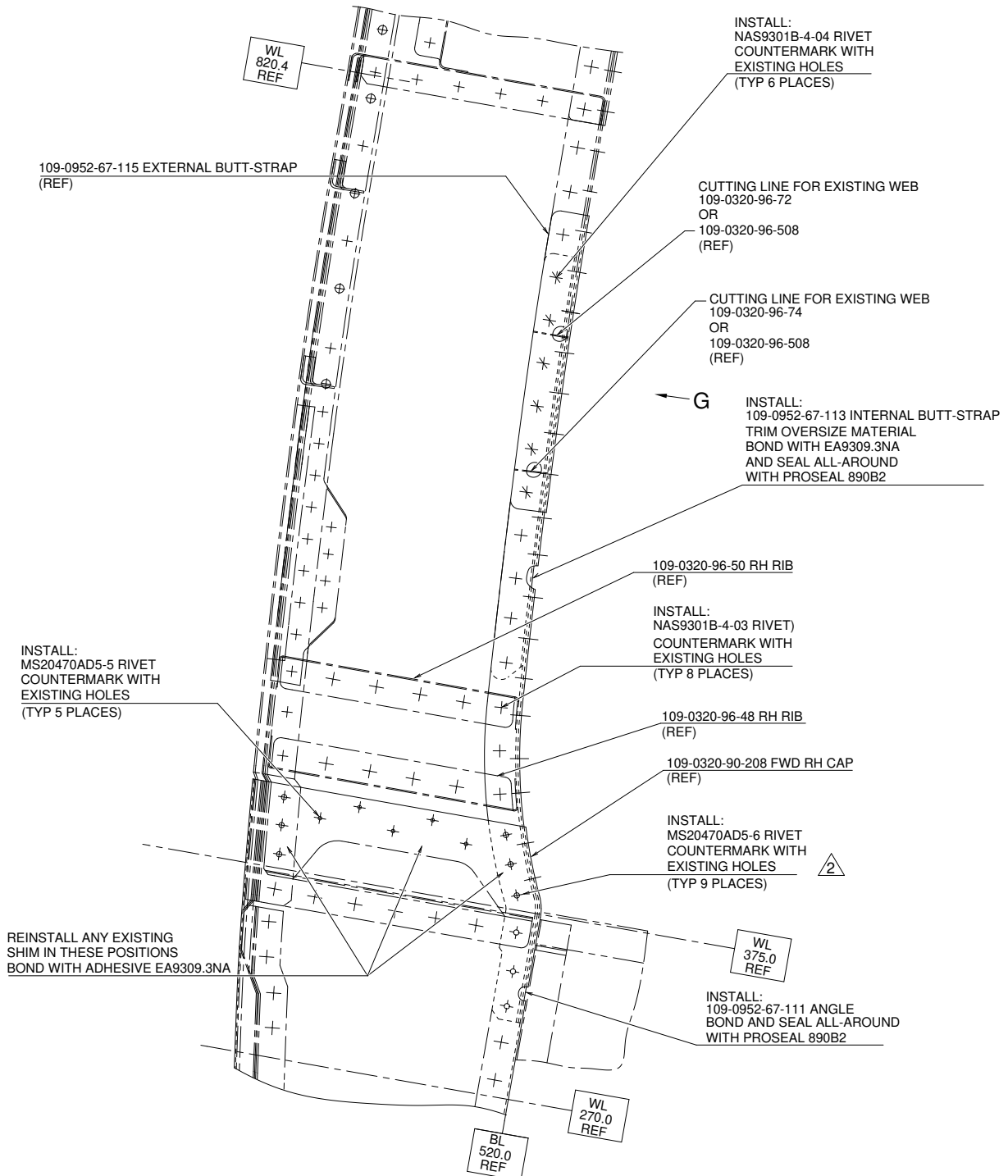

VIEW C
STRUCTURES AND SYSTEMS ARE PARTIALLY
OMITTED FOR BETTER CLARITY PURPOSE

Figure 32

S.B. N°109EP-173 ALERT
DATE: November 10, 2020
REVISION: B - August 24, 2023

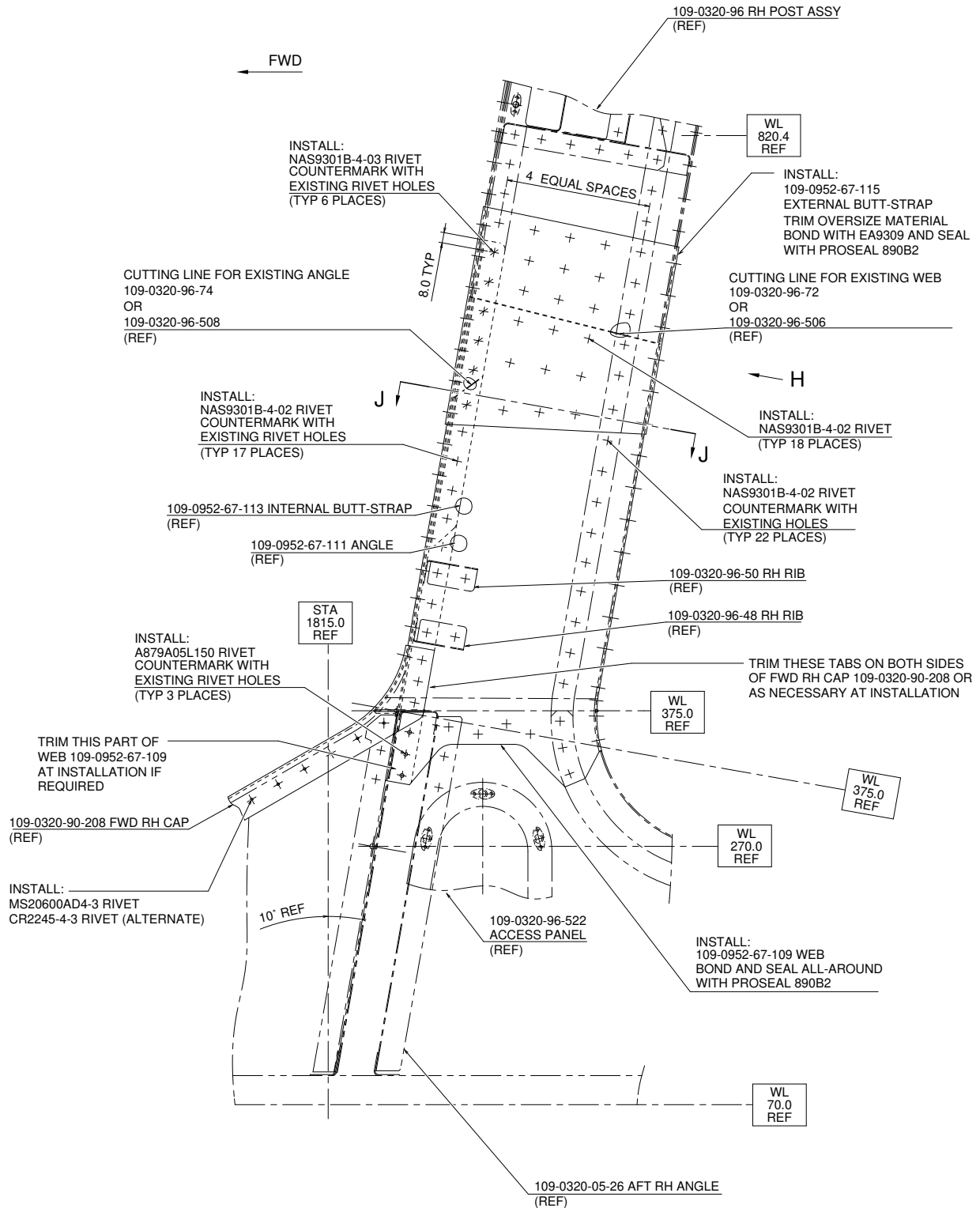

VIEW G
VIEW LOOKING OUTBOARD RH SIDE
STRUCTURES AND SYSTEMS ARE PARTIALLY
OMITTED FOR BETTER CLARITY PURPOSE

Figure 33

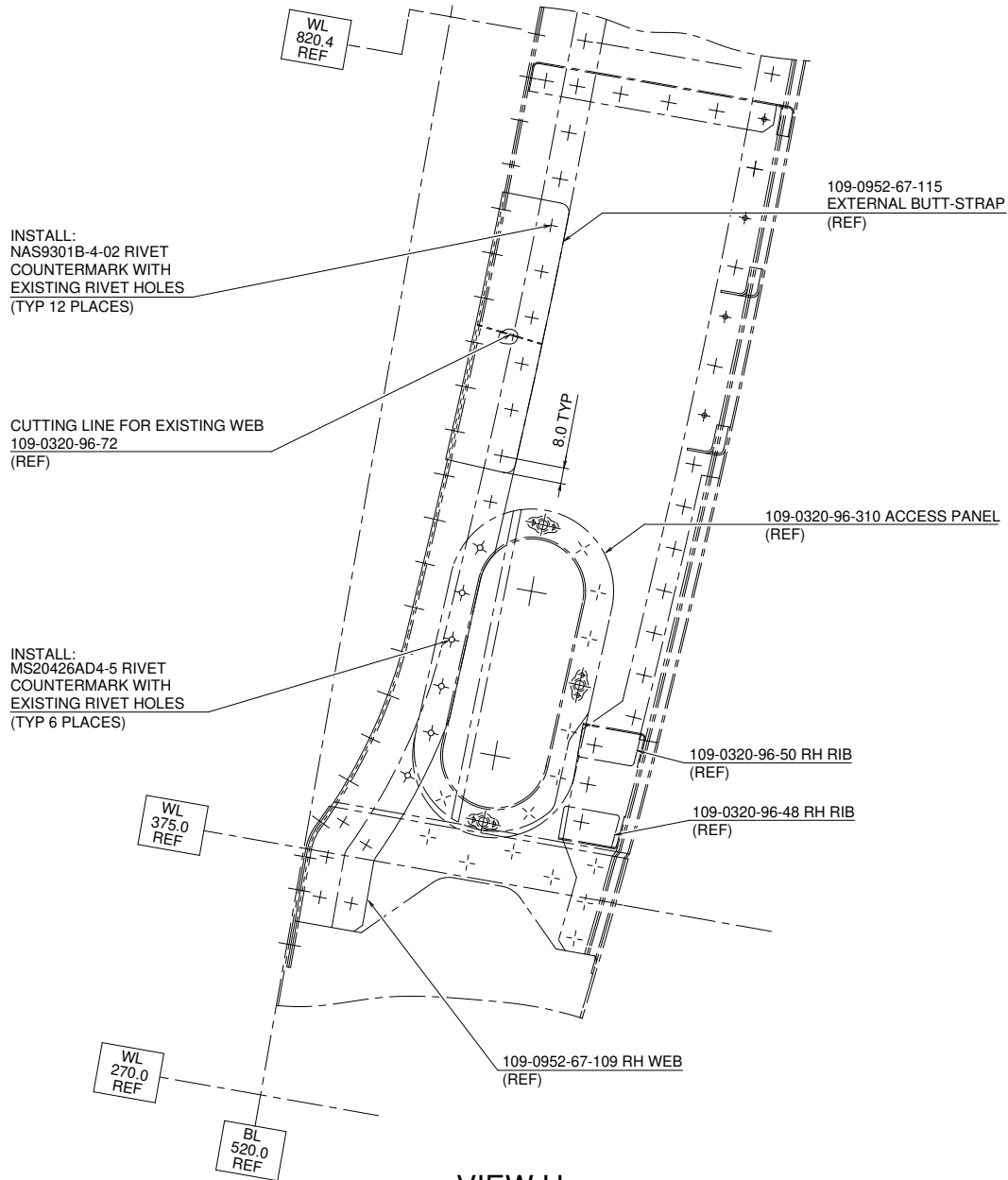

STRUCTURES AND SYSTEMS ARE PARTIALLY OMITTED FOR BETTER CLARITY PURPOSE

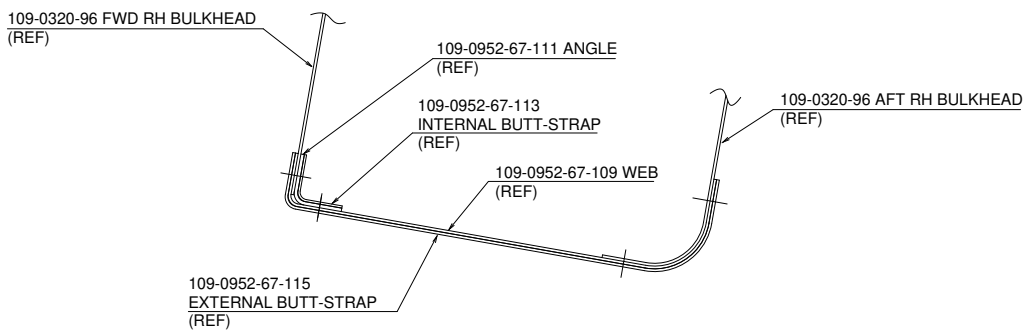

STRUCTURES AND SYSTEMS ARE PARTIALLY OMITTED FOR BETTER CLARITY PURPOSE

Figure 34

S.B. N°109EP-173 ALERT
DATE: November 10, 2020
REVISION: B - August 24, 2023

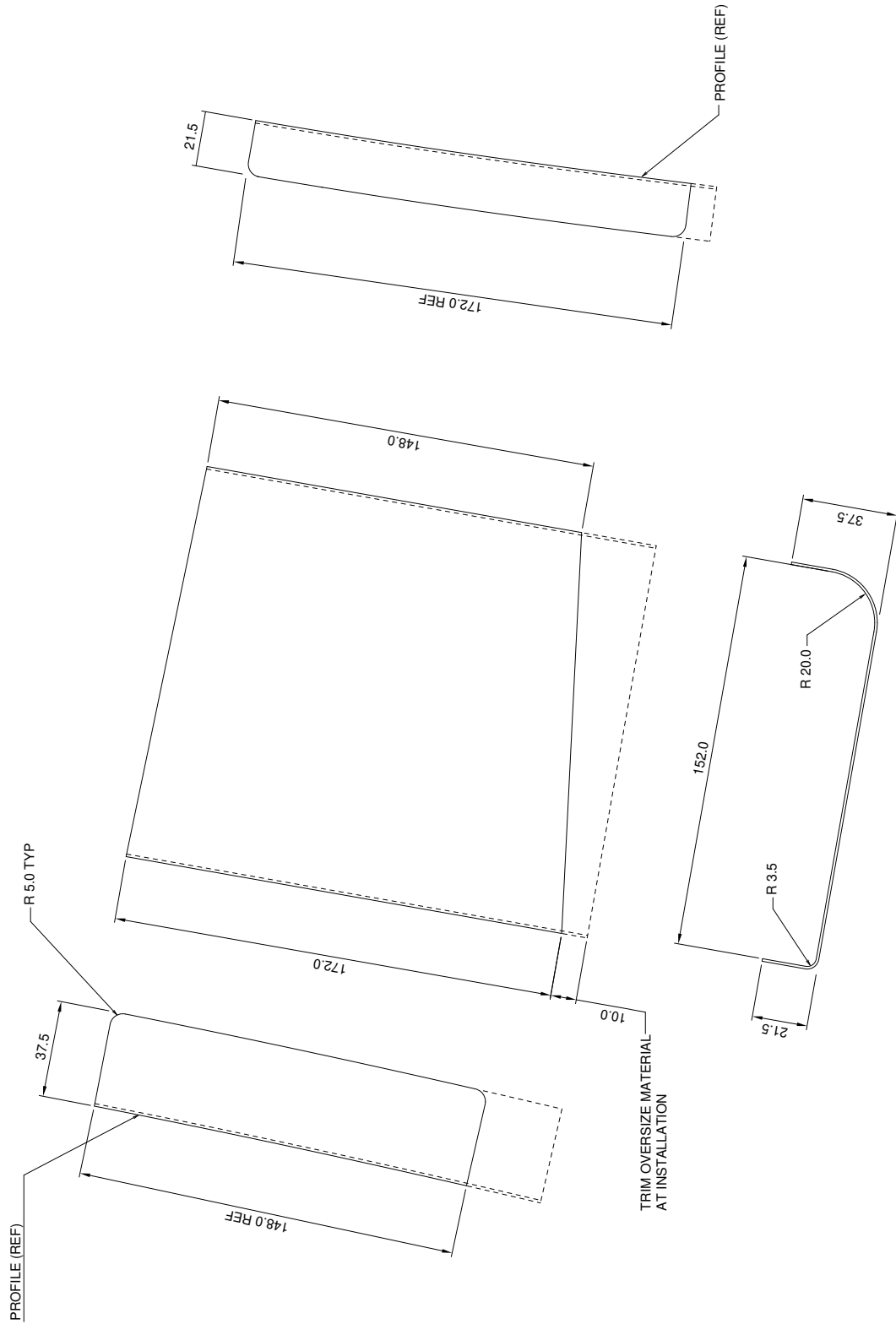

NOTE: THE FINAL DIMENSION SHOWN IS INDICATIVE. VERIFY ALWAYS WITH POSITION OF EXISTING RIVETS BEFORE TO TRIM.

109-0952-67-115 EXTERNAL BUTT-STRAP
(ADAPT TO PROFILE OF POST AT INSTALLATION IF NECESSARY)

Figure 35

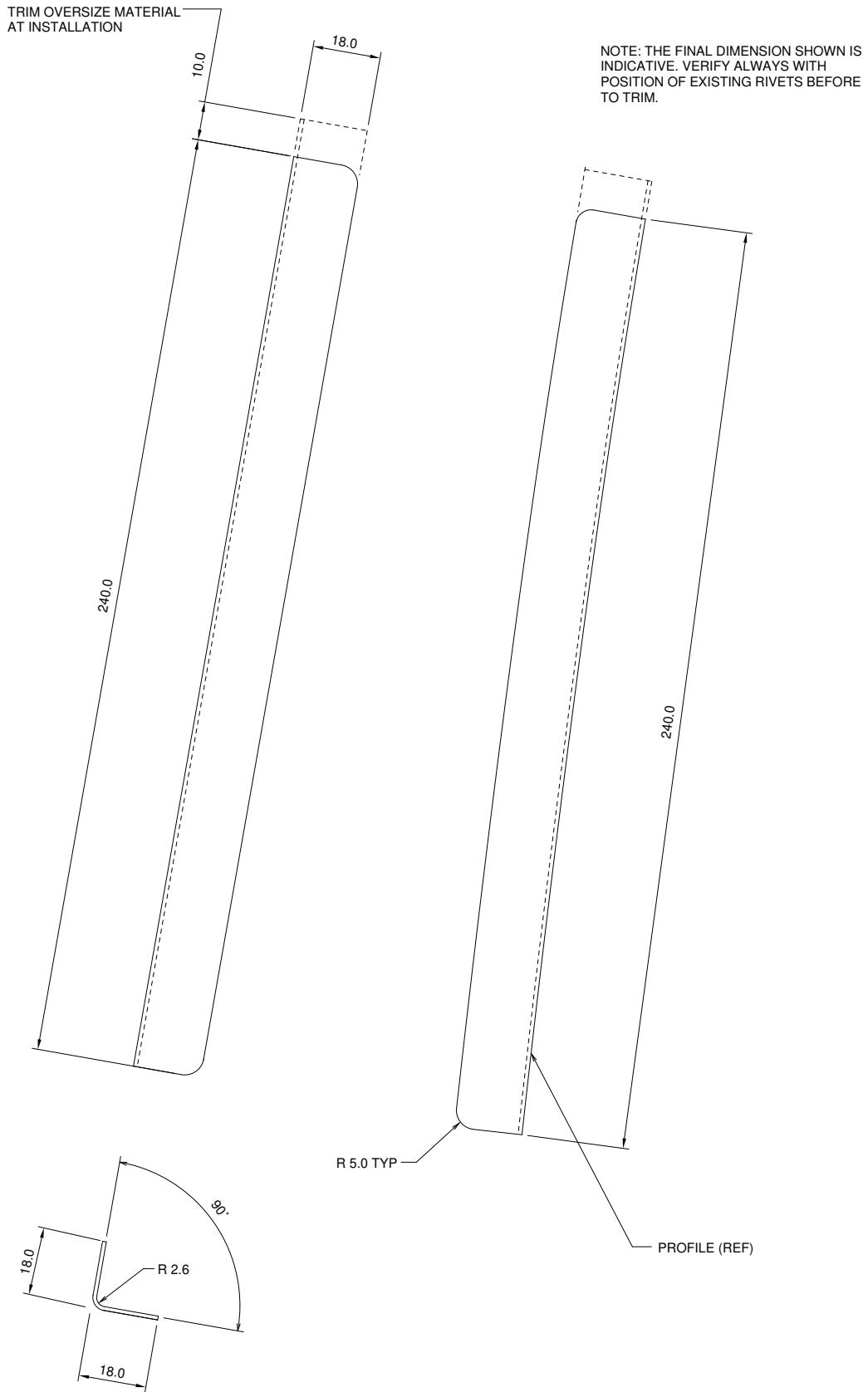

109-0952-67-113 INTERNAL BUTT-STRAP
(ADAPT TO PROFILE OF POST AT INSTALLATION IF NECESSARY)

Figure 36

S.B. N°109EP-173 ALERT
DATE: November 10, 2020
REVISION: B - August 24, 2023

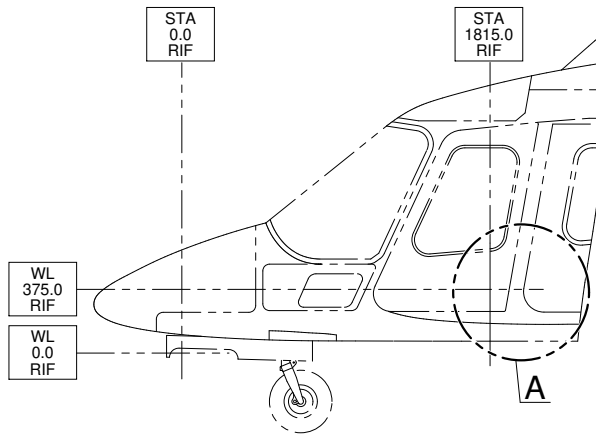

109G5330E01-201
LATERAL MOUNTING REINFORCEMENT
INSTALLATION LH (SHOWN)

109G5330E01-202
LATERAL MOUNTING REINFORCEMENT
INSTALLATION RH (OPPOSITE)

109G5330E01-203
ANGLE REPAIR INSTALLATION LH
(SHOWN)

109G5330E01-204
ANGLE REPAIR INSTALLATION RH
(OPPOSITE)

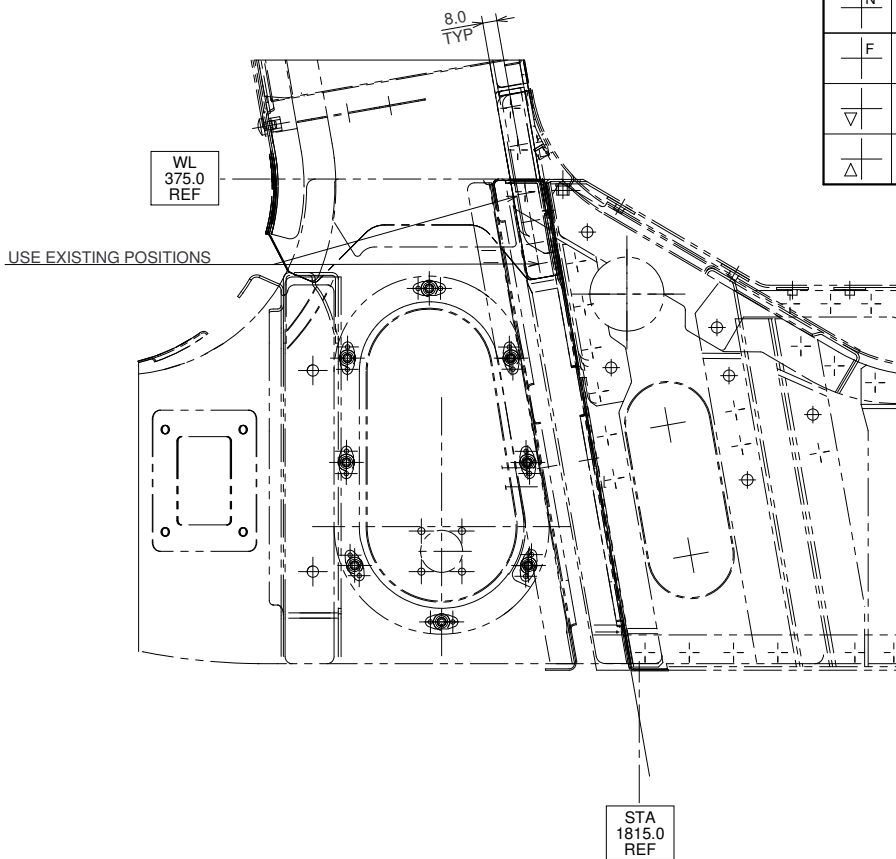

VIEW LOOKING OUTBOARD
(LEFT SIDE SHOWN TYP RIGHT SIDE EXCEPT AS SHOWN)
STRUCTURES AND SYSTEMS ARE PARTIALLY
OMITTED FOR BETTER CLARITY PURPOSE

Figure 37

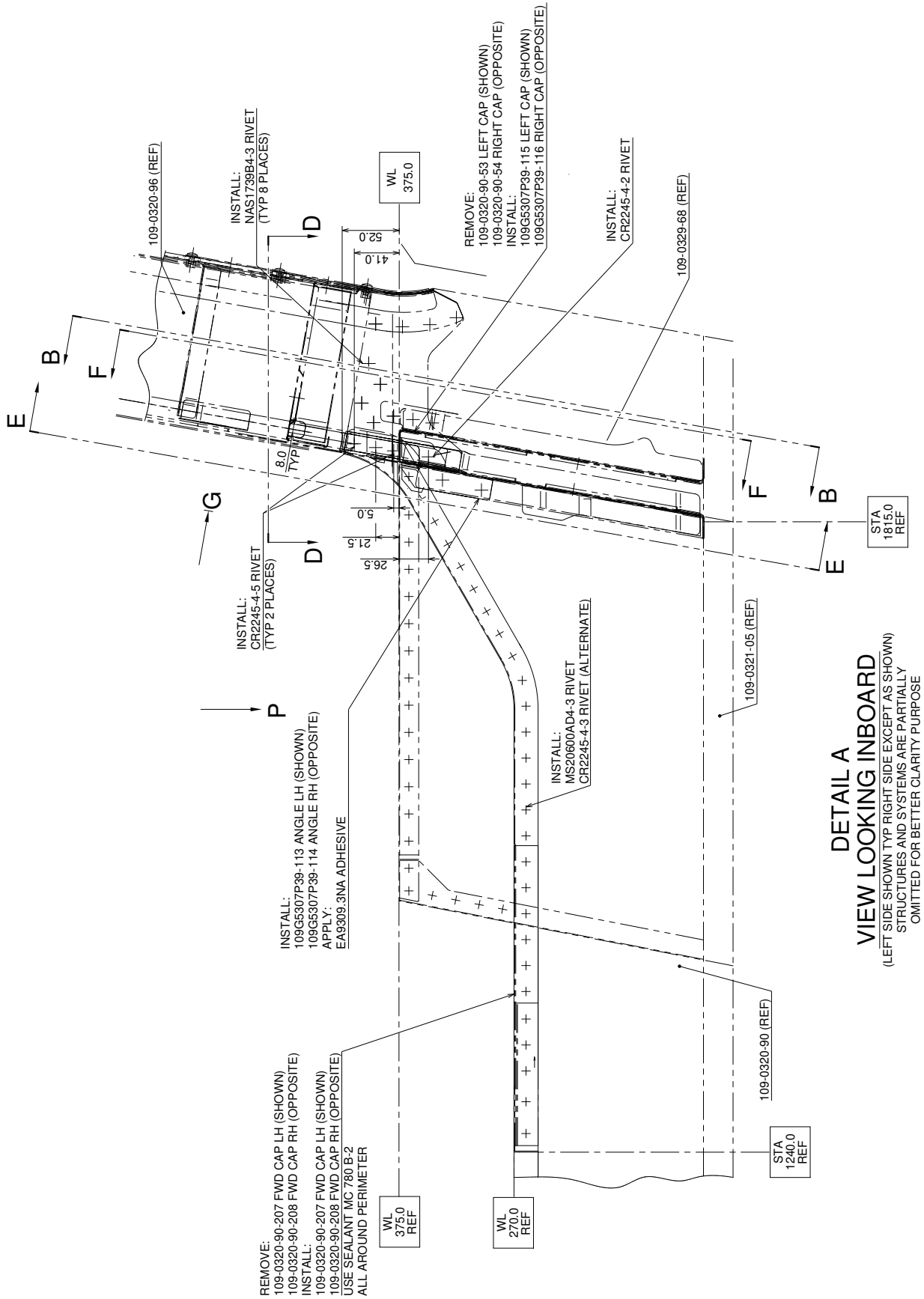

DETAIL A
VIEW LOOKING INBOARD
(LEFT SIDE SHOWN TYP RIGHT SIDE EXCEPT AS SHOWN)
STRUCTURES AND SYSTEMS ARE PARTIALLY
OMITTED FOR BETTER CLARITY PURPOSE

Figure 38

S.B. N°109EP-173 ALERT
DATE: November 10, 2020
REVISION: B - August 24, 2023

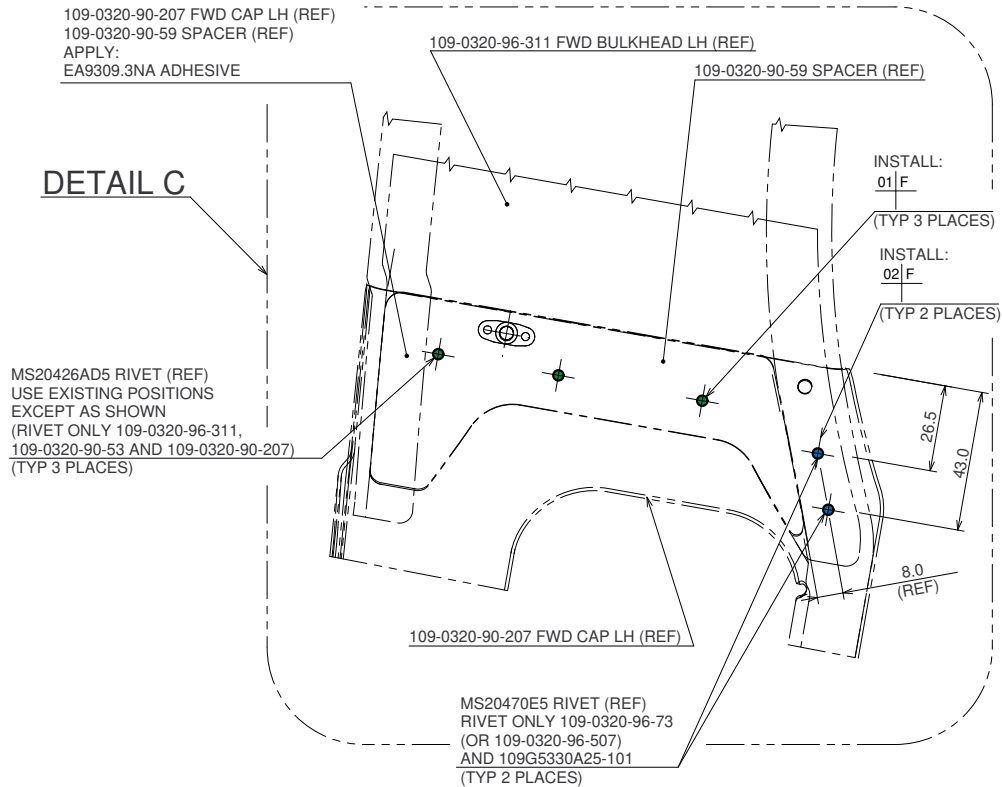

VIEW B-B

(LH SIDE ONLY)
(OMITTED 109G5330A25-101 FOR CLARITY)
STRUCTURES AND SYSTEMS ARE PARTIALLY
OMITTED FOR BETTER CLARITY PURPOSE

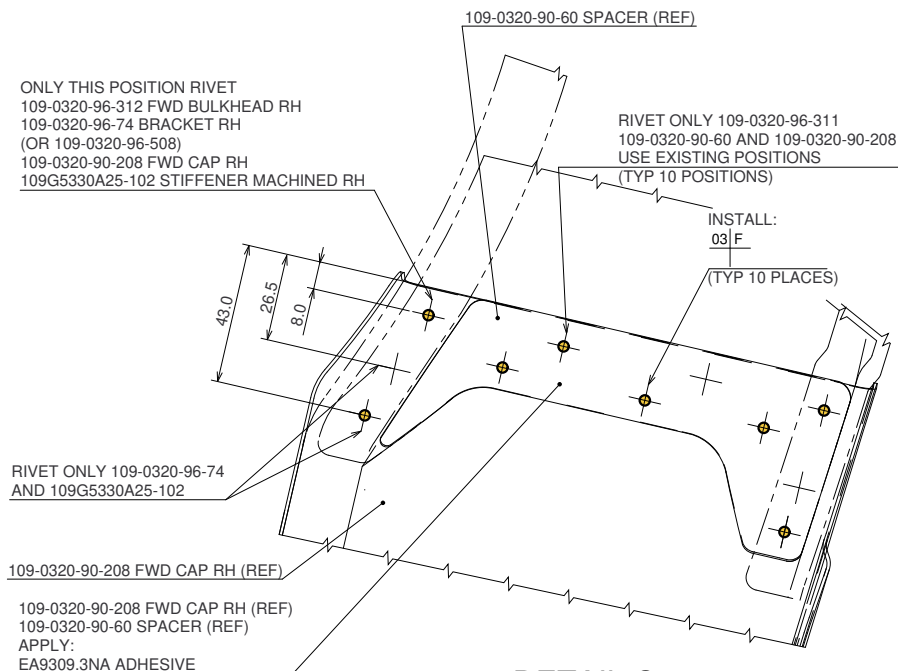

DETAIL C

(RH SIDE ONLY)
(OMITTED 109G5330A25-102 FOR CLARITY)
STRUCTURES AND SYSTEMS ARE PARTIALLY
OMITTED FOR BETTER CLARITY PURPOSE

Figure 39

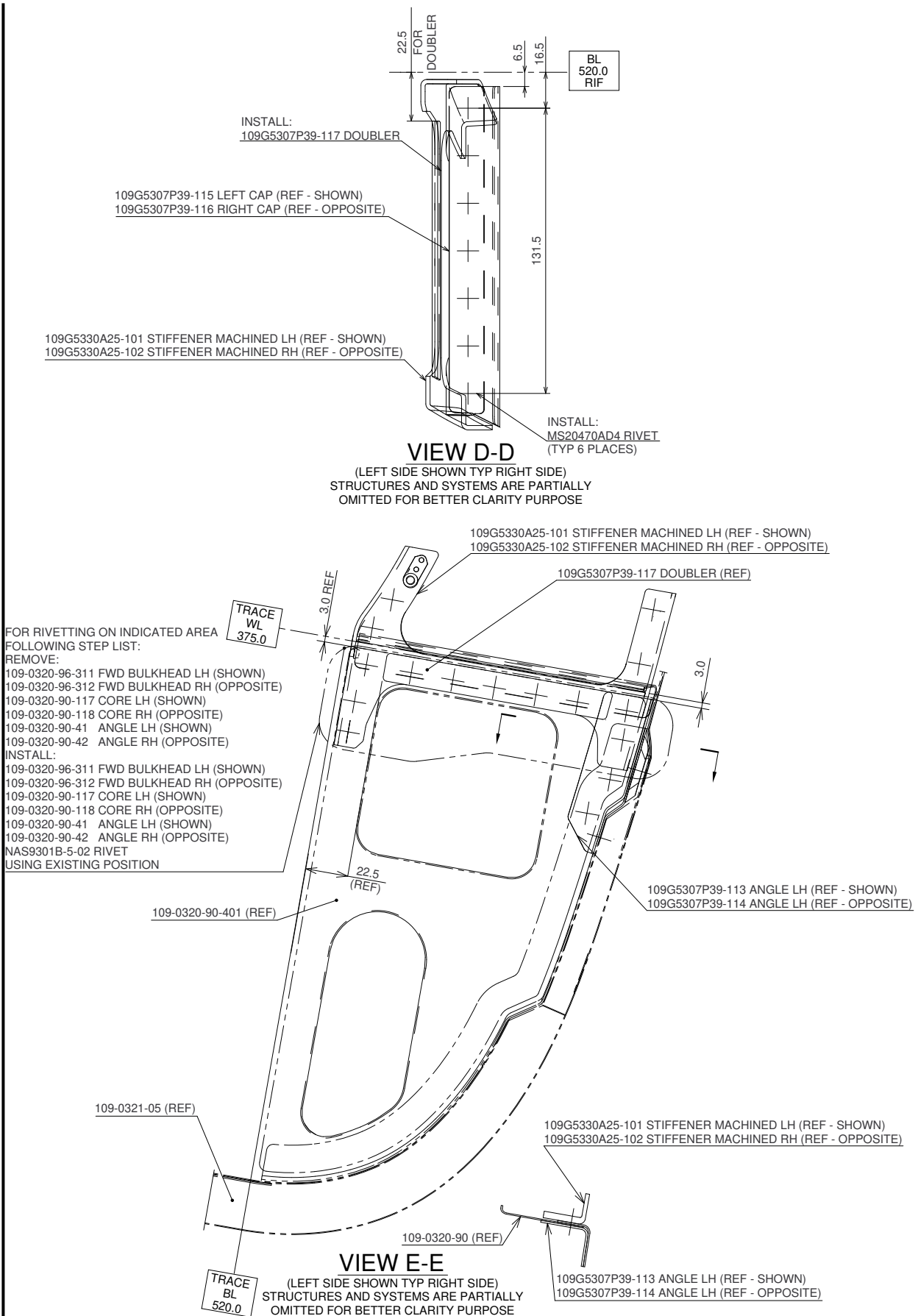
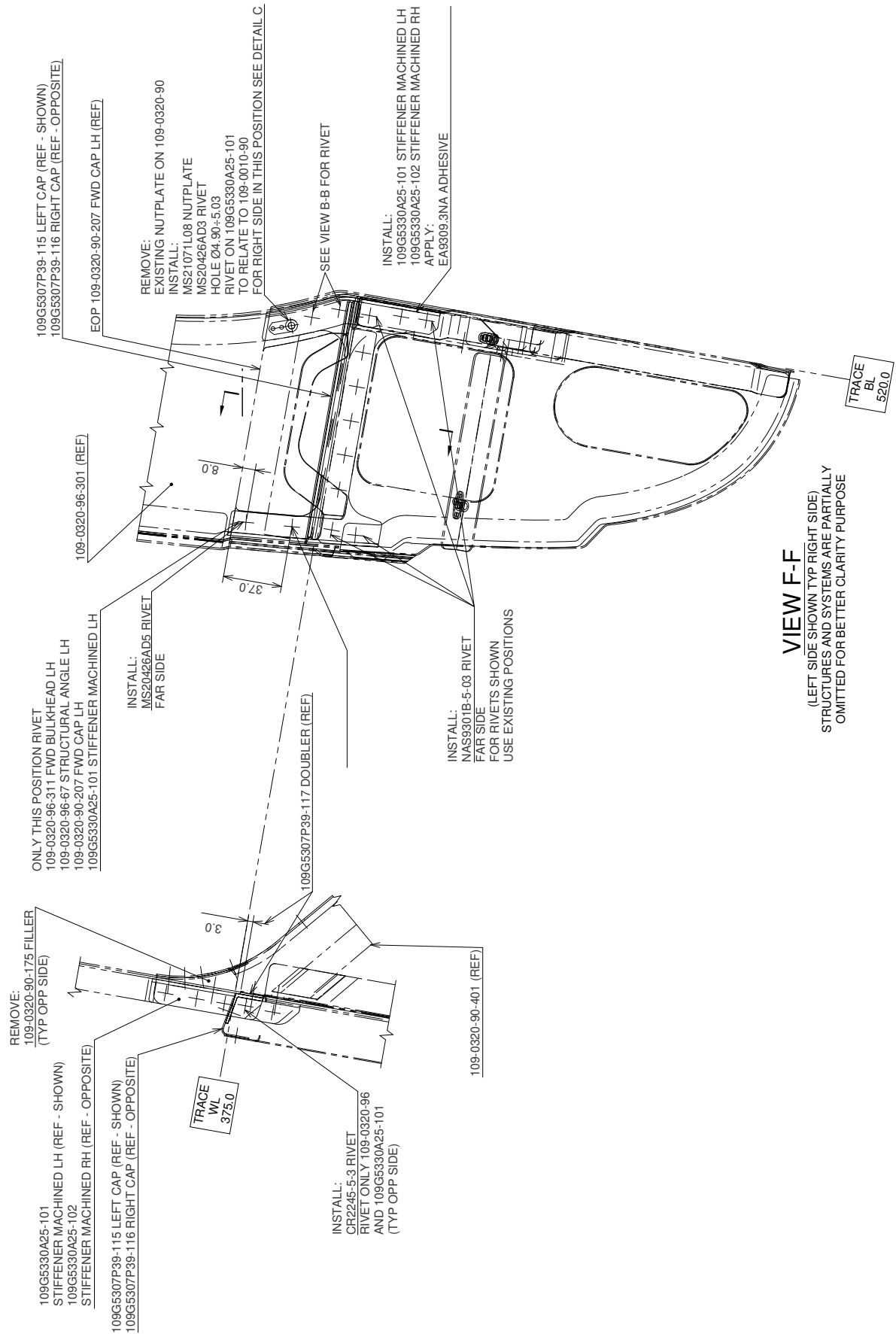

Figure 40

S.B. N°109EP-173 ALERT
DATE: November 10, 2020
REVISION: B - August 24, 2023



VIEW F-F
(LEFT SIDE SHOWN TYP RIGHT SIDE)
STRUCTURES AND SYSTEMS ARE PARTIALLY
OMITTED FOR BETTER CLARITY PURPOSE

Figure 41

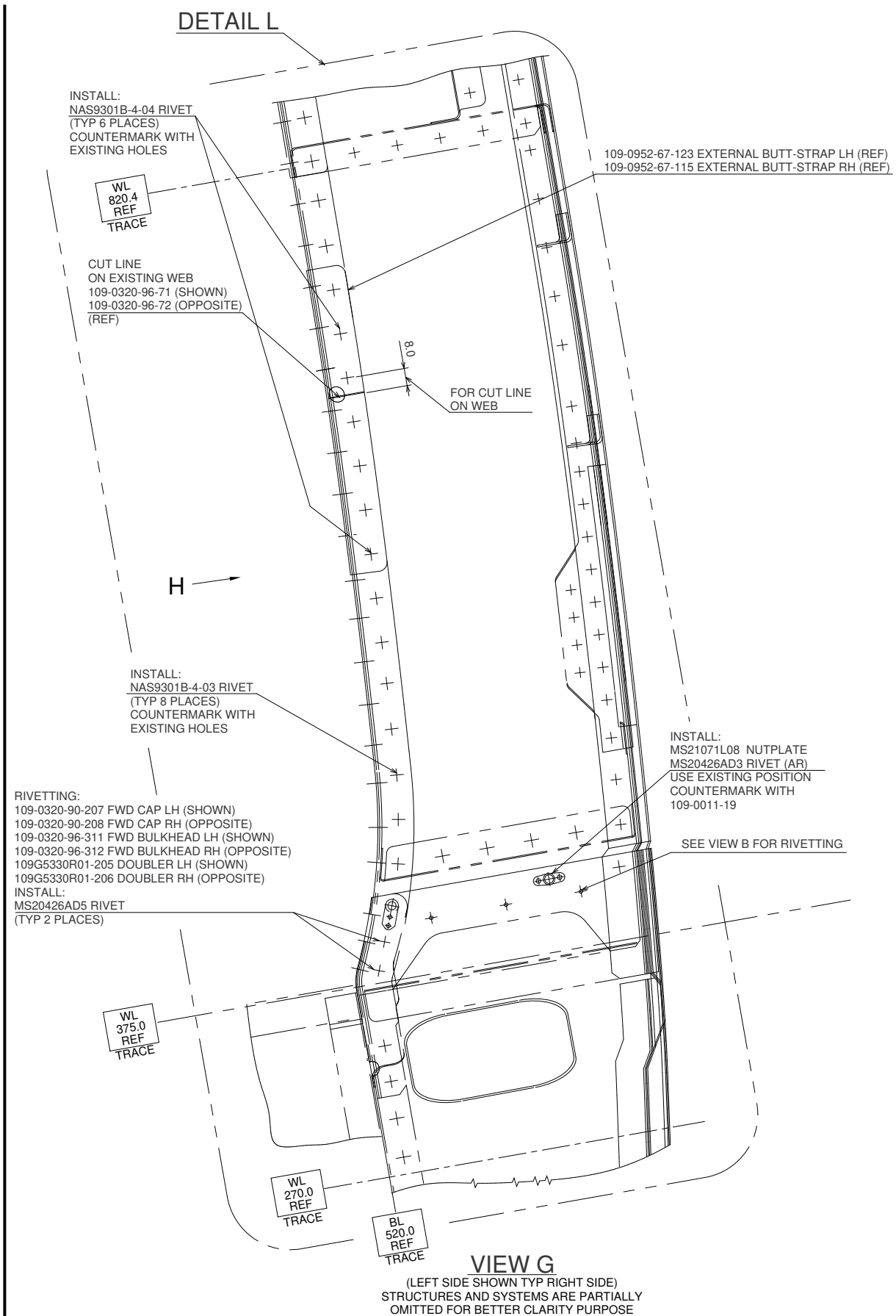

Figure 42

S.B. N°109EP-173 ALERT
DATE: November 10, 2020
REVISION: B - August 24, 2023

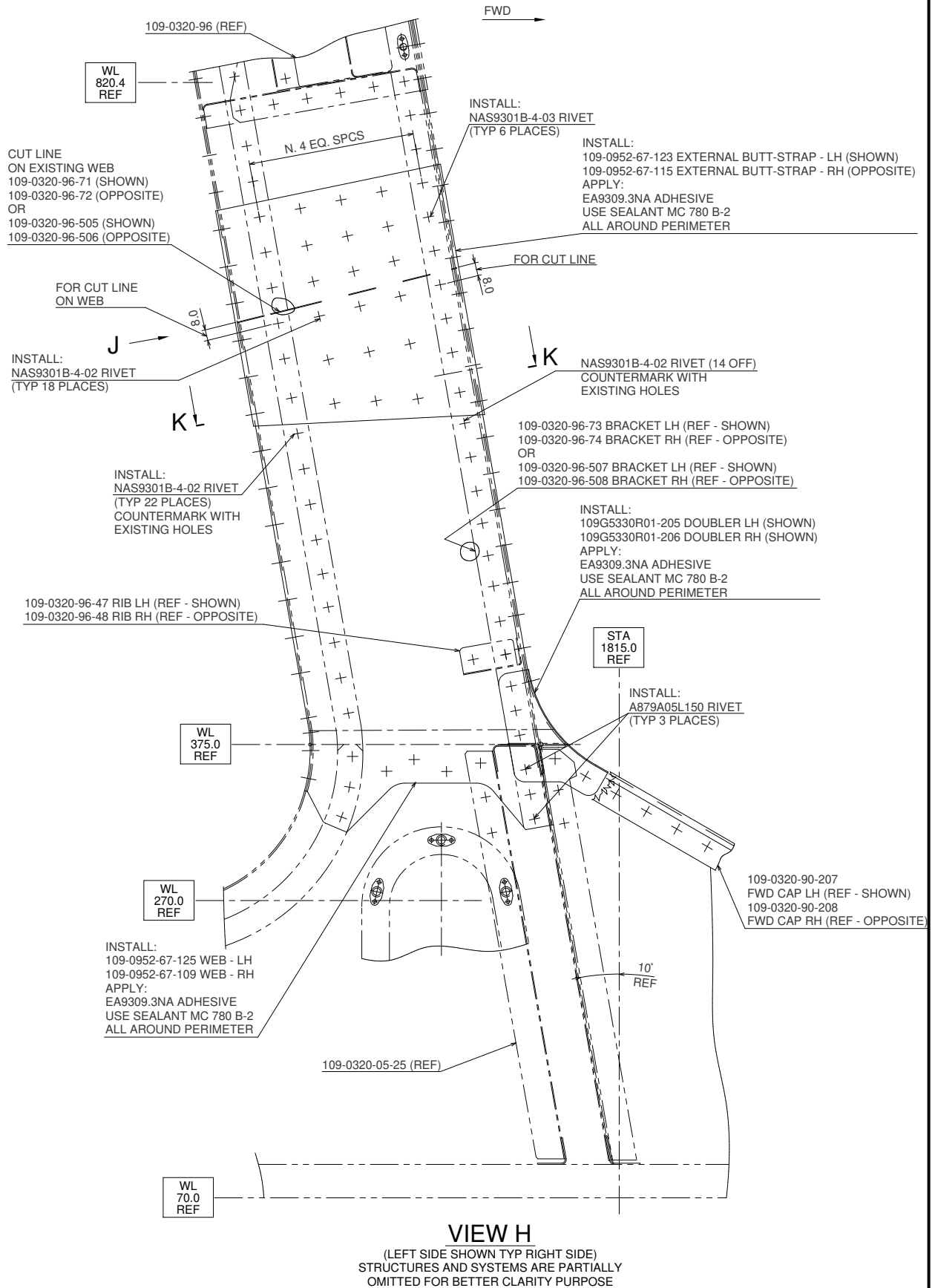

Figure 43

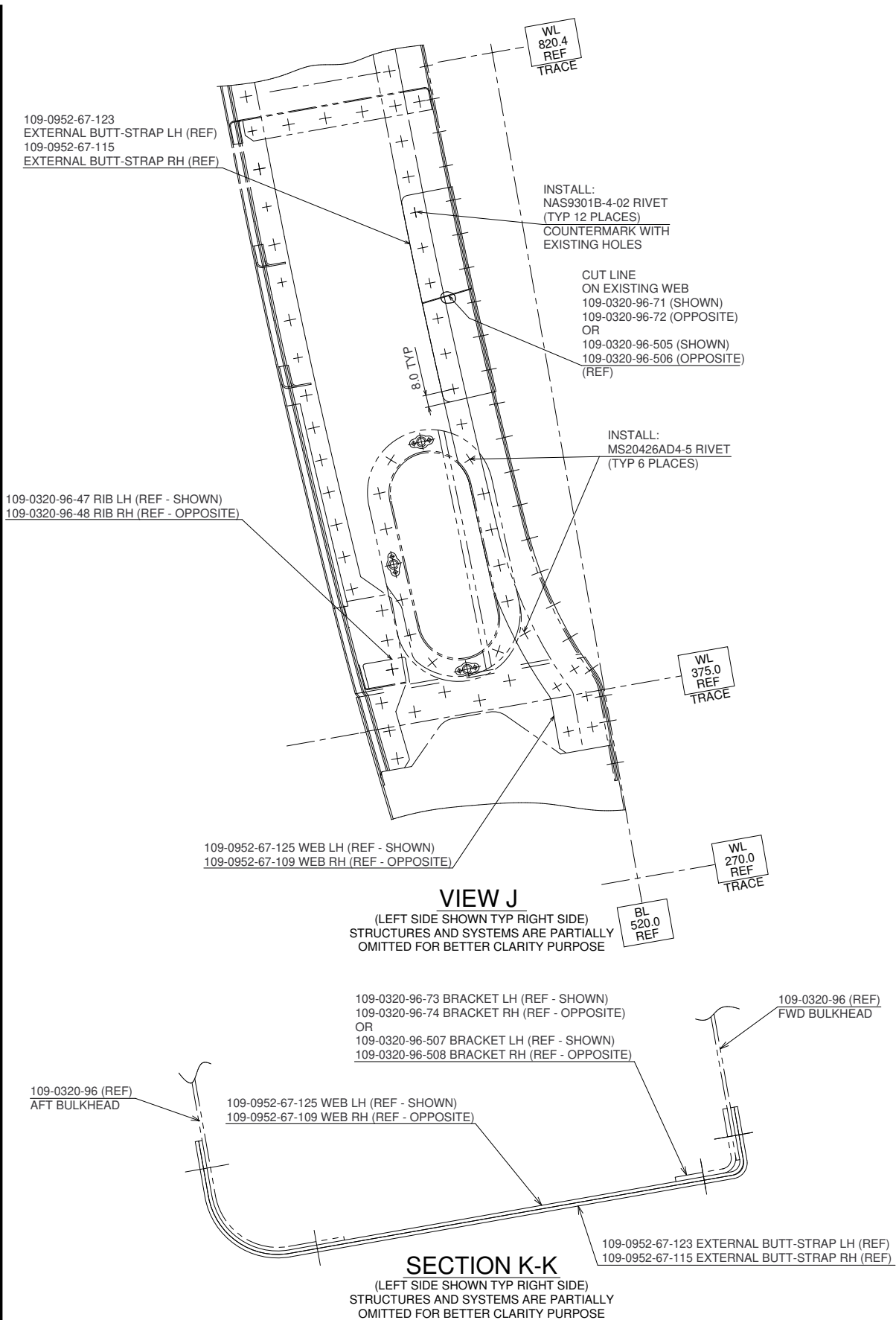

Figure 44

S.B. N°109EP-173 ALERT
DATE: November 10, 2020
REVISION: B - August 24, 2023

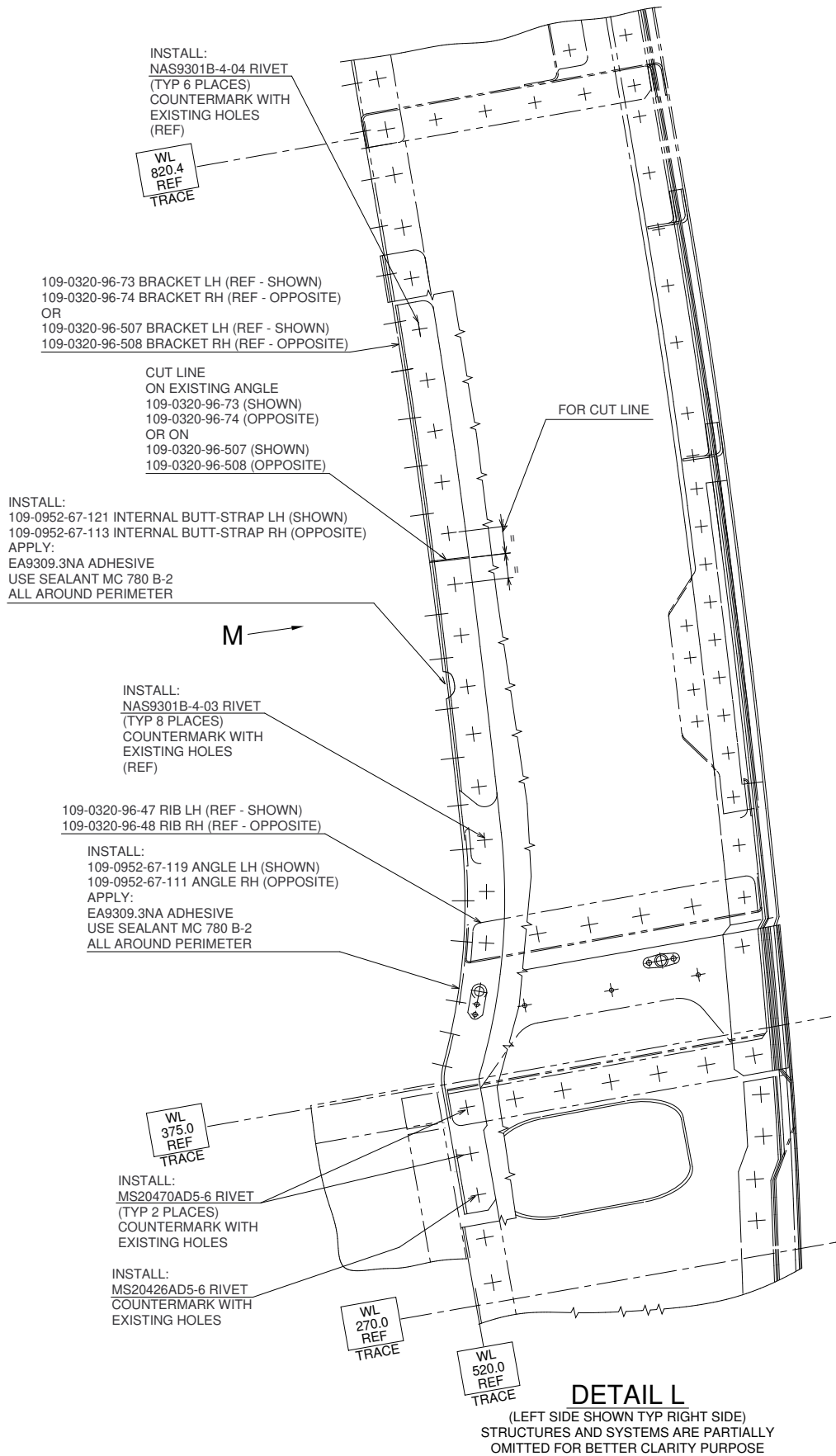

Figure 45

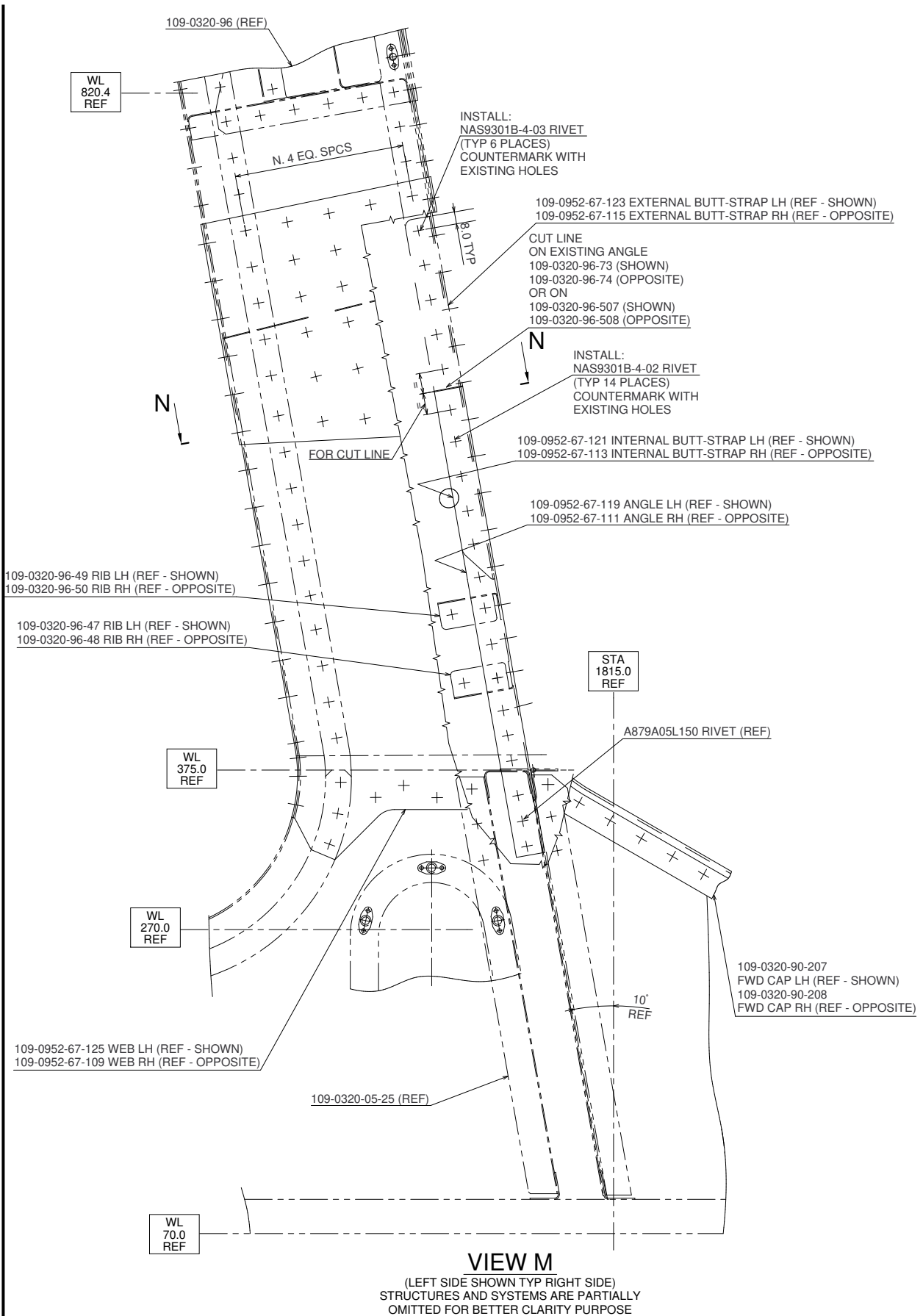
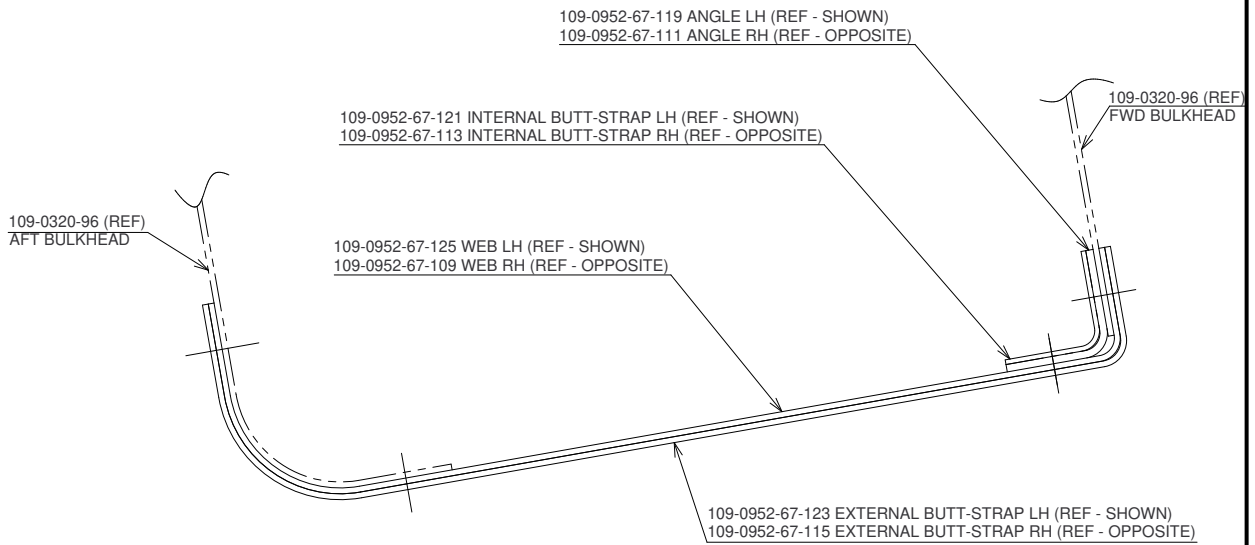
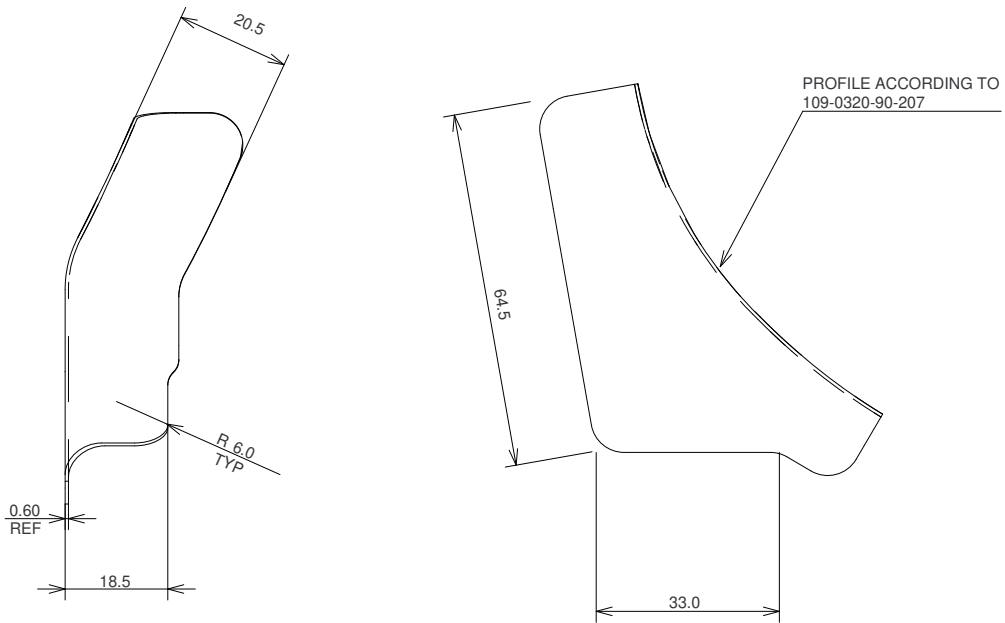

Figure 46

S.B. N°109EP-173 ALERT
DATE: November 10, 2020
REVISION: B - August 24, 2023



SECTION N-N
(LEFT SIDE SHOWN TYP RIGHT SIDE)
STRUCTURES AND SYSTEMS ARE PARTIALLY
OMITTED FOR BETTER CLARITY PURPOSE



ITEM DETAIL
109G5330R01-205/-206
(LEFT SIDE SHOWN TYP RIGHT SIDE)
STRUCTURES AND SYSTEMS ARE PARTIALLY
OMITTED FOR BETTER CLARITY PURPOSE

Figure 47

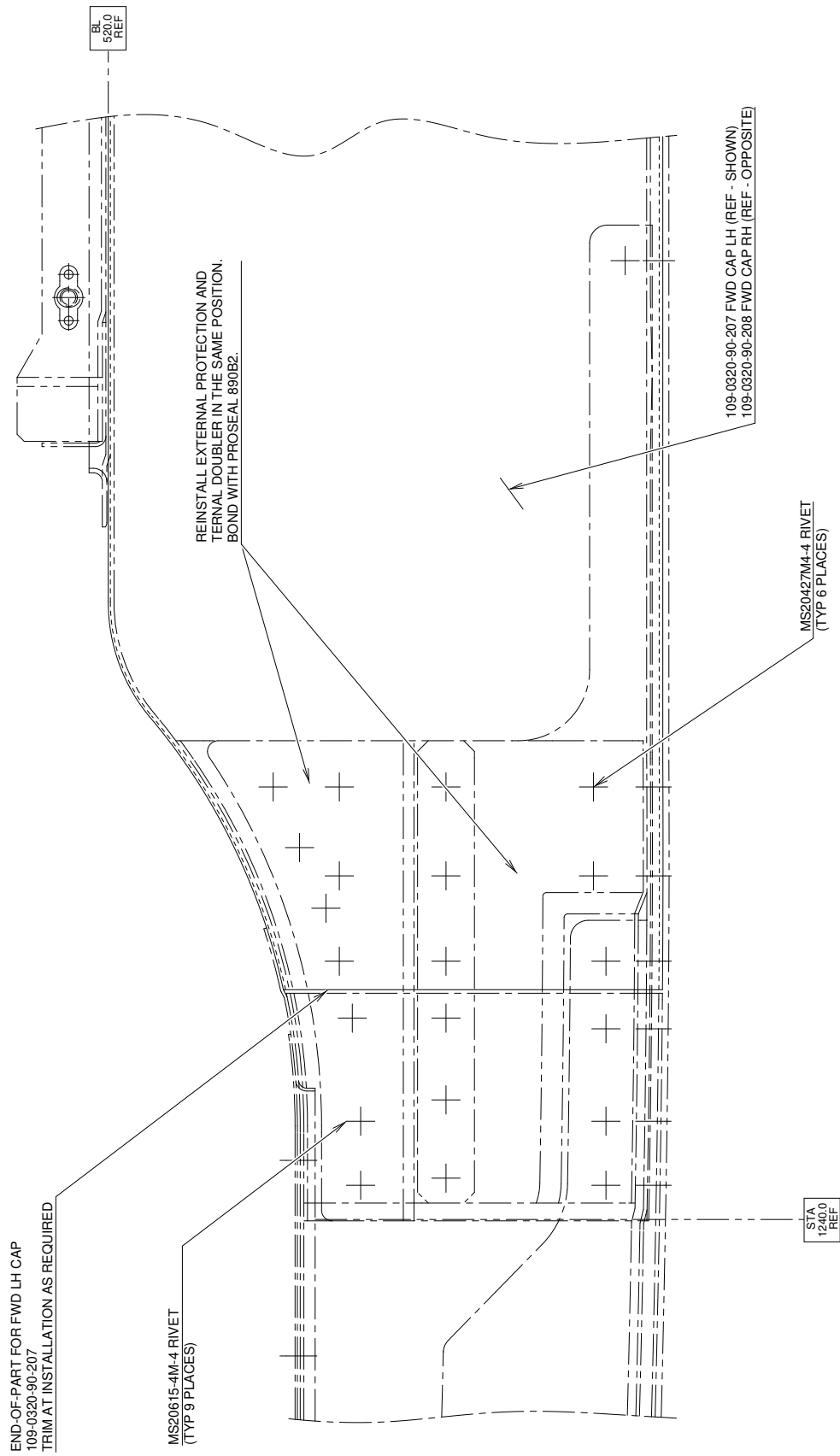

VIEW P
(LH SIDE SHOWN TYP RIGHT SIDE)
STRUCTURES AND SYSTEMS ARE PARTIALLY
OMITTED FOR BETTER CLARITY PURPOSE

Figure 48

S.B. N°109EP-173 ALERT
DATE: November 10, 2020
REVISION: B - August 24, 2023

