SERVICE BULLETIN**N° 109EP-173****ALERT****DATE:** November 10, 2020**REV. :** A - July 21, 2022

TITLE**ATA 53 - CENTRAL FUSELAGE FRAME ASSY AT STA 1815, INSPECTION AND REPAIR OF****REVISION LOG**

Revision A is issued in order to introduce the following changes:

- Modify COMPLIANCE of PART II and PART III;
- Modify ACCOMPLISHMENT INSTRUCTIONS in PART I.

Revision bars identify changes.

1. PLANNING INFORMATION

A. EFFECTIVITY

All the A109E helicopters from S/N 11001 thru S/N 11674 included.

B. COMPLIANCE

NOTE

The helicopter's posts that have been repaired in accordance with Part II (LH side) or Part III (RH side) of this Service Bulletin, or in accordance with repair drawing P/N 109-0952-67-117 (LH side) or P/N 109-0952-67-102 (RH side), shall be inspected in accordance with Part I after they have accumulated more than 1000 FH of 3500 landings since repair.

Helicopter that have accumulated more than 1000FH or 3500 landings, whichever occurs first:

- **PART I:**
Within and not later than 100FH from the issuance of this SB and every 100FH thereafter.
- **PART II AND PART III:**
 - Within and not later than the next 25FH if the length of crack on the FWD CAP does not exceed 50 mm and no other damages are detected in the affected area.

NOTE

If the length of the cracks exceeds the boundaries of the FWD CAP, INNER FORWARD ANGLE or WEB (ref. Figure 1), the repair scheme reported in Part II and III of this Service Bulletin could not be applicable. In this case contact Leonardo Engineering Dept engineering.support.lhd@leonardo.com before the next flight.

- Before the next flight if the length of crack on the FWD CAP is greater than 50 mm and/or any other crack(s) are detected.

Helicopter that have accumulated up to 1000FH or 3500 landings, whichever occurs first:

- PART I:

Within and not later 100FH upon the achievement of 1000FH or 3500 landings and every 100FH thereafter.

- PART II AND PART III:

- Within and not later than the next 25FH if the length of crack on the FWD CAP does not exceed 50 mm and no other damages are detected in the affected area.

NOTE

If the length of the cracks exceeds the boundaries of the FWD CAP, INNER FORWARD ANGLE or WEB (ref. Figure 1), the repair scheme reported in Part II and III of this Service Bulletin could not be applicable. In this case contact Leonardo Engineering Dept engineering.support.lhd@leonardo.com before the next flight.

- Before the next flight if the length of crack on the FWD CAP is greater than 50 mm and/or any other crack(s) are detected.

C. CONCURRENT REQUIREMENTS

N.A.

D. REASON

This Service Bulletin is issued in order to provide the necessary instruction on how to perform an inspection to detect cracks in the center fuselage at intersection of lateral pylon (LH and RH side) with floor spar, and, in case of findings, to repair it.

E. DESCRIPTION

Some occurrences of cracks have been found in the fuselage of the Leonardo S.p.a. A109E helicopters at the intersection of the lateral pylon with the floor spar at the STA 1815, either in the LH and RH side.

In Part I of this Service Bulletin are given the instruction to perform an inspection in the area affected by the possible cracks, in Part II are given the instruction for LH side fuselage repair and in Part III are given the instruction for RH side fuselage repair.

F. APPROVAL

The technical content of this Service Bulletin is approved under the authority of DOA nr. EASA.21.J.005. For helicopters registered under other Aviation Authorities, before applying the Service Bulletin, applicable Aviation Authority approval must be checked within Leonardo Helicopters customer portal.

EASA states mandatory compliance with inspections, modifications or technical directives and related time of compliance by means of relevant Airworthiness Directives.

If an aircraft listed in the effectivity embodies a modification or repair not LHD certified and affecting the content of this Service Bulletin, it is responsibility of the Owner/Operator to obtain a formal approval by Aviation Authority having jurisdiction on the aircraft, for any adaptation necessary before incorporation of the present Service Bulletin.

G. MANPOWER

To comply with this Service Bulletin the following MMH are deemed necessary:

Part I: approximately 6 (six) hours;

Part II: approximately 120 (one hundred and twenty) hours;

Part III: approximately 120 (one hundred and twenty) hours.

MMH are based on hands-on time and can change with personnel and facilities available.

H. WEIGHT AND BALANCE

PART I, II and III:

N.A.

I. REFERENCES

1) PUBLICATIONS

<u>DATA MODULE</u>	<u>DESCRIPTION</u>	<u>PART</u>
DM01 00-20-1	Helicopter safety	I, II, III
DM02 06-40-1	Access panels and doors	II, III
DM03 00-10-4	Connection/disconnection of external electrical power	II, III
DM04 00-10-8	Connection/disconnection of external hydraulic power	II, III
DM05 25-11-9	Crew seats - removal/installation	II, III

<u>DATA MODULE</u>	<u>DESCRIPTION</u>	<u>PART</u>
DM06 25-21-12	Forward seat - removal/installation	II, III
DM07 21-21-1	Air distribution system	II, III
DM08 52-11-9	LH/RH cockpit doors - removal/installation	II, III
DM09 67-11-1	Collective pitch control system	II
DM10 67-11-9	Collective pitch control lever - removal/installation	II
DM11 67-21-1	Tail rotor control system	II
DM12 25-81-7	Cockpit soundproofing panels - removal/installation	I, II, III
DM13 25-81-9	Passenger soundproofing panels - removal/installation	I, II, III
DM14 52-71-6	Operational test of cockpit/passenger compartment caution system	II, III
DM15 67-12-1	Cyclic pitch control system	III
DM16 67-00-12	Control tube - general maintenance	II, III
DM17 07-30-1	Hoisting of complete helicopter	II, III
DM18 07-30-2	Hoisting of helicopter without main rotor	II, III

2) ACRONYMS

AR	As Required
DOA	Design Organization Approval
EASA	European Aviation Safety Agency
LHD	Leonardo Helicopters Division
LS	Local Supply
MMH	Maintenance Man Hours
N.A.	Not Applicable
P/N	Part Number
SB	Service Bulletin
S/N	Serial Number

3) ANNEX

N.A.

J. PUBLICATIONS AFFECTED

A109E-MM Maintenance Manual A109E Helicopter Model.

A109E-MPM Maintenance Planning Manual A109E Helicopter Model.

3C-A-ASRP-00-X - AW119/A109 Series Air Vehicle Structural Repair Publication.

K. SOFTWARE ACCOMPLISHMENT SUMMARY

N.A.

2. MATERIAL INFORMATION

A. REQUIRED MATERIALS

1) PARTS

PART I

N.A.

PART II

#	P/N	ALTERNATIVE P/N	DESCRIPTION	Q.TY	LVL	NOTE	LOG P/N
1	109-0952-67-117		REPAIR ASSY, LH	REF	.		-
2	109-0320-90-207	109-0320-90-207A1	Cap, forward LH	1	..	(1)	-
3	109-0320-90-7		Panel	REF	..	(1)(2)	-
4	109-0320-90-507		Cap, forward LH	1	..	(3)	-
5	109-0320-90-505		Panel	REF	..	(3)(4)	-
6	109-0952-67-119		Angle	1	..		709-052L1
7	109-0952-67-121		Internal butt-strap	1	..		709-052L1
8	109-0952-67-123		External butt-strap	1	..		709-052L1
9	109-0952-67-125		Web	1	..		709-052L1
10	109-0360-88-109		Seal assy, co-pilot door	1	..	(5)	709-052L1
11	A233A001B	AW004FE001B	Fastener, seal	36	..		709-052L1
12	109-0360-86-109		Seal assy, LH passenger door	1	..	(5)	709-052L1
13	A879A05L150		Rivet, solid	5	..		709-052L1
14	MS27039-1-08		Screw	8	..		709-052L1
15	MS20426AD3-5		Rivet, solid, 100° countersunk head	0.1kg	..		709-052L1
16	MS20426AD3-6		Rivet, solid, 100° countersunk head	0.1kg	..		709-052L1
17	MS20426AD4-5		Rivet, solid, 100° countersunk head	0.1kg	..		709-052L1
18	MS20426AD5-5		Rivet, solid, 100° countersunk head	0.1kg	..		709-052L1
19	MS20426AD5-6		Rivet, solid, 100° countersunk head	0.1kg	..		709-052L1
20	MS20426AD5-8		Rivet	0.1kg	..		709-052L1
21	MS20426AD5-9		Rivet	0.1kg	..		709-052L1
22	MS20470AD5-5		Rivet, solid, universal head	0.1kg	..		709-052L1
23	MS20470AD5-6		Rivet, solid, universal head	0.1kg	..		709-052L1
24	MS20470AD5-7		Rivet	0.1kg	..		709-052L1
25	MS21069L08		Nut plate, self-locking	1	..		709-052L1
26	MS21071L08		Nut plate, self-locking	1	..		709-052L1
27	NAS9301B-4-02		Rivet, blind, protruding head	100	..		709-052L1
28	NAS9301B-4-03		Rivet, blind, protruding head	20	..		709-052L1
29	NAS9301B-4-04		Rivet, blind, protruding head	10	..		709-052L1
30	MS24665-151		Cotter Pin	2	..		709-052L1
31	MS24665-155		Cotter Pin	2	..		709-052L1
32	MS20615-4M3		Rivet, universal head	0.1kg	..		709-052L1
33	MS20427M4-3		Rivet, 100° countersunk head	0.1kg	..		709-052L1
34	MS20600AD4-3	MS20600AD4W3	Rivet, blind	80	..		709-052L1
35	NAS1720H4L4A		Rivet, blind	80	..		709-052L1
36	NAS1721H4L2A		Rivet, blind	30	..		709-052L1

#	P/N	ALTERNATIVE P/N	DESCRIPTION	Q.TY	LVL	NOTE	LOG P/N
37	NAS1721H4L4A		Rivet, blind	20	..		709-052L1

PART III

#	P/N	ALTERNATIVE P/N	DESCRIPTION	Q.TY	LVL	NOTE	LOG P/N
38	109-0952-67-102		REPAIR ASSY, RH	REF	.		-
39	109-0320-90-208	109-0320-90-208A1	Cap, forward RH	1	..		709-052L2
40	109-0320-90-8		Panel	REF	..	(6)	-
41	109-0952-67-111		Angle	1	..		709-052L2
42	109-0952-67-113		Internal butt-strap	1	..		709-052L2
43	109-0952-67-115		External butt-strap	1	..		709-052L2
44	109-0952-67-109		Web	1	..		709-052L2
45	109-0360-88-110		Seal assy, co-pilot door	1	...	(7)	709-052L2
46	A233A001B	AW004FE001B	Fastener, seal	36	..		709-052L2
47	109-0360-86-110		Seal assy, LH passenger door	1	..	(7)	709-052L2
48	A879A05L150		Rivet, solid	5	..		709-052L2
49	MS20426AD4-5		Rivet, solid, 100° countersunk head	0.1kg	..		709-052L2
50	MS20470AD5-5		Rivet, solid, universal head	0.1kg	..		709-052L2
51	MS20470AD5-6		Rivet, solid, universal head	0.1kg	..		709-052L2
52	MS20470AD5-7		Rivet	0.1kg	..		709-052L2
53	MS20470AD5-8		Rivet	0.1kg	..		709-052L2
54	MS20470AD5-9		Rivet	0.1kg	...		709-052L2
55	NAS9301B-4-02		Rivet, blind, protruding head	100	..		709-052L2
56	NAS9301B-4-03		Rivet, blind, protruding head	20	..		709-052L2
57	NAS9301B-4-04		Rivet, blind, protruding head	10	..		709-052L2
58	MS24665-151		Cotter Pin	4	..		709-052L2
59	MS20615-4M3		Rivet, universal head	0.1kg	..		709-052L2
60	MS20615-4M4		Rivet, 100° countersunk head	0.1kg	..		709-052L2
61	MS20600AD4-3	MS20600AD4W3	Rivet, blind	80	..		709-052L2
62	NAS1720H4L4A		Rivet, blind	80	..		709-052L2
63	NAS1721H4L2A		Rivet, blind	30	...		709-052L2
64	NAS1721H4L4A		Rivet, blind	20	..		709-052L2

2) CONSUMABLES

The following consumable materials, or equivalent, are necessary to accomplish this Service Bulletin:

#	Spec./LHD code number	DESCRIPTION	Q.TY	NOTE	PART
65	199-05-002 TY I, CI 2 (cod. 900000581)	Adhesive EA9309.3NA (C100)	AR	(8)	II, III
66	199-05-004 TY II, CI 2 (cod. 900001586)	Sealant Proseal 890B2 (C148)	AR	(8)(11)	II, III
67	AWMS05-001TY I, CI B, Gr 2 (cod. 99999999000015245)	Sealant MC-780 B-2 (C501)	AR	(8)(11)	II, III
68	MIL-PRF-23377 TY I, CI C2 (cod. 99999999000010181)	Primer, epoxy-polyamide (446)	AR	(8)	II, III
69	Commercial	Soft lint-free cloth (011)	AR	(8)	I, II, III
70	MIL-PRF-680 TY II	Cleaning solvent (C287)	AR	(8)	I, II; III
71	Commercial	Masking tape (C064)	AR	(8)	II, III
72	Commercial	Scotch-Brite (C015)	AR	(8)	II, III

Refer also to AMDI for the consumable materials required to comply with the MM Paragraphs referenced in the accomplishment instructions.

3) LOGISTIC MATRIX

In order to apply this Service Bulletin, the following Logistic P/N can be ordered in accordance with the applicable notes:

LOGISTIC P/N	Q.TY (PER HELO)	NOTE	PART
709-052L1	1	(9)	II
709-052L2	1	(10)	III
109-0320-90-207	1	(1)	II
109-0320-90-7	1	(1)(2)	II
109-0320-90-507	1	(3)	II
109-0320-90-505	1	(3)(4)	II
109-0320-90-8	1	(6)	III

NOTE

- (1) Item required for helicopters from S/N 11001 thru S/N 11600.
- (2) This item can be obtained reworking the existing panel P/N 109-0320-90-7.
- (3) Item required for helicopters from S/N 11601 thru S/N 11674.
- (4) This item can be obtained reworking the existing panel P/N 109-0320-90-505.
- (5) Seal assy co-pilot door P/N 109-0360-88-109 and seal assy LH passenger door P/N 109-0360-86-109 will be obtained from gasket P/N A232A001BB. Q.ty 7 m are required to comply with Part II of this Service Bulletin.
- (6) This item can be obtained reworking the existing panel P/N 109-0320-90-8.
- (7) Seal assy pilot door P/N 109-0360-88-110 and seal assy RH passenger door P/N 109-0360-86-110 will be obtained from gasket P/N A232A001BB. Q.ty 7 m are required to comply with Part III of this Service Bulletin.
- (8) Local supply.
- (9) Required for LH side fuselage repair.
- (10) Required for RH side fuselage repair.
- (11) These materials are alternatives

B. SPECIAL TOOLS

The following special tools, or equivalent, are necessary to accomplish this Service Bulletin:

#	P/N	DESCRIPTION	Q.TY	NOTE	PART
73	109-3000-01-41 or 109-3000-03-143	Flight controls rigging pin set	1	(B1)(B2)	II, III
74	GB941-009-000 or equivalent	Hydraulic system test bench	1	(B1)(B2)	II, III
75	GPU400 or equivalent	Electric power unit	1	(B1)(B2)	II, III
76	109-3900-01-1	Hoisting ring, main transmission	1	(B1)(B2)	II, III

Refer also to PTUM for the special tools required to comply with the MM Paragraphs referenced in the accomplishment instructions.

SPECIAL TOOLS NOTE

(B1) Commercial item used for general maintenance. Local supply.

(B2) If necessary, please contact Leonardo Helicopters Division order administration to request the tools supply on loan. As soon as the present Service Bulletin is implemented the tools supplied on loan shall be promptly returned to Leonardo Helicopters Division.

C. INDUSTRY SUPPORT INFORMATION

WARRANTY: Owners/Operators who comply with the instructions of this Service Bulletin no later than the applicable date in the “Compliance” section will be eligible to receive **REQUIRED MATERIALS** on free of charge basis, except for Consumable Materials and Special Tools.

NOTE: Customers who fail to comply with the instructions in this Service Bulletin before the compliance date are not eligible for the aforementioned special policy.

Please Issue relevant MMIR form to your Warranty Administration Dpt.

Please Issue relevant MMIR form to your Warranty Administration Dpt, accompanied by **INSPECTION REPORT** and **PICTURE** of the affected area.

NOTE: The **INSPECTION REPORT** and **PICTURE** are mandatory; in case the MMIR is not accompanied by these documents, it will be rejected.

3. ACCOMPLISHMENT INSTRUCTIONS

GENERAL NOTES

- a) Place an identification tag on all components that are re-usable, including the attaching hardware that has been removed to gain access to the modification area and adequately protect them until their later re-use.
- b) Shape the cables in order to prevent interference with the structure and the other existing installations, using where necessary suitable lacing cords.
- c) Exercise extreme care during drilling operations to prevent instruments, cables and hoses damage.
- d) After drilling, remove all swarf and sharp edges. Apply on bare metal a light film of primer unless the hole is used for ground connection.
- e) During the installation of bonding braids or components requiring grounding, clean the surface structure in order to obtain a good ground contact.
- f) Let adhesive cure at room temperature for at least 24 hours unless otherwise specified.
- g) Exposed thread surface and nut must be protected using a layer of tectyl according to MIL-C-16173 grade I.
- h) Refer to CSRP-A-CSRP-00-X for the applicable structural standard practice procedures.
- i) Refer to AMP Chapter 20 for the applicable standard torque values for threaded fasteners.
- j) All lengths are in mm.

PART I

1. In accordance with MM Paragraph 00-20-1, prepare the helicopter on ground for a safe maintenance. Disconnect the battery, all electrical power sources and/or the external power supply.
2. With reference to Figure 1, open both the passenger doors and both the cockpit doors and secure them in opened position to gain access to the indicated areas.

3. If installed, remove any item of furnishing on the passenger compartment that might prevent the access to the inspection zone.
4. If installed, in accordance with MM Paragraphs 25-81-7 and 25-81-9, remove the cockpit and passenger compartment soundproofing panels or the moquette lining that might prevent the access to the inspection zone.
5. With reference with Figure 2, on both lateral posts, remove the access panels on the aft side (P/N 109-0320-96-309 on LH side and P/N 109-0320-96-310 on RH side) and on the inboard side (P/N 109-0320-96-521 on LH side and P/N 109-0320-96-522 on RH side). Retain all the fixing hardware for later reuse.
6. If necessary, clean the inspection areas using a soft lint-free cloth (not soaked) and cleaning solvent MIL-PRF-680 Type II or equivalent.
7. With reference to Figure 1, using a bright source of light, visually inspect the whole zone of intersection between the lateral post and the floor spar, on both sides of the fuselage, for evidence of cracks. Pay particular attention to the forward area of the post (toward cockpit) and to inboard side of the post.
8. In case of no findings, reinstall all the component removed from Step 3 to Step 5 and proceed to Step 10.
9. In case of findings, in accordance with CSRP standard repair procedures perform a fluorescent liquid penetrant inspection of the crack to determine the exact extent, then stop-drill at both ends of crack to relieve the stresses in the extremities and to prevent any further propagation.
 - 9.1 If the length of crack on the FWD CAP does not exceed 50 mm and no other damages are detected in the affected area, proceed in accordance with PART II (LH side of fuselage) or PART III (RH side of fuselage) of this Service Bulletin within and not later than the next 25 flight hours otherwise.
 - 9.2 If the length of crack on the FWD CAP is greater than 50 mm and/or any other crack(s) are detected but not exceeding the boundaries of the FWD CAP, INNER FORWARD ANGLE or WEB (ref. Figure 1) proceed in accordance with PART II (LH side of fuselage) or PART III (RH side of fuselage) of this Service Bulletin before the next flight.
 - 9.3 If the length of the cracks exceeds the boundaries of the FWD CAP, INNER FORWARD ANGLE or WEB (ref. Figure 1), the repair scheme reported in this Service Bulletin could not be applicable. In this case contact Leonardo Engineering Dept at the following mail box: engineering.support.lhd@leonardo.com.
10. Return the helicopter to a ready to flight condition and record for compliance with Part I of this Service Bulletin on the helicopter logbook.
11. Send the attached compliance form to the following mail box:

engineering.support.lhd@leonardo.com

As an alternative, gain access to My Communications section on Leonardo WebPortal and compile the “Service Bulletin Application Communication”.

PART II

1. In accordance with MM Paragraph 00-20-1, prepare the helicopter on ground for a safe maintenance. Disconnect the battery, all electrical power sources and/or the external power supply.
2. Verify the correct rigging of the collective control and of the tail rotor control as follows:

NOTE

The procedures shown in the paragraphs that follow must be performed, prior to removal of control rods, to assure that the rigging of the collective pitch control and of the tail rotor pitch control system is correct. This will allow, after reinstallation of the control rods, to find any defect due to improper installation.

- 2.1 Put a suitable platform adjacent to the left side of the fuselage.
- 2.2 In accordance with MM Paragraph 06-40-1, remove the access panels P17 and D6.
- 2.3 In accordance with MM Paragraph 00-10-8, connect the hydraulic test bench to helicopter and operate at 1500 psi.
- 2.4 In accordance with MM Paragraph 00-10-4, connect the electrical power unit to helicopter. Apply power to AFCS system to assure the correct travel of the flight controls. Open the FORCE TRIM and AUTO TRIM circuit breakers on the overhead panel, in order to prevent the unwanted stiffening or sudden return of the flight controls at the release.
- 2.5 With reference to Figure 3 and Figure 10 find the areas of stops for collective control and tail rotor control.
- 2.6 With reference to Figure 10, put a thin sheet of paper between the tail rotor pitch control lever and the forward stop (left pedal master stop). Push the left pedal fully forward and try to remove the paper sheet by pulling it downward: the paper sheet must tear.
- 2.7 With reference to Figure 10, put another sheet of paper between the tail rotor pitch control lever and the aft stop (right pedal master stop). Push the right pedal fully forward and try to remove the paper sheet by pulling it downward: the paper sheet must tear.
- 2.8 With reference to Figure 9, install the rigging pins on the longitudinal and lateral cyclic lever. This assures that both the longitudinal and lateral cyclic are at the 50 percent of the travel.

- 2.9 With reference to Figure 5, put a thin sheet of paper between the minimum collective stop (fixed) and the control lever. Move the pilot or co-pilot collective lever fully downward, and then try to remove the paper sheet by pulling it: the paper sheet must tear.
- 2.10 With reference to Figure 5, put another sheet of paper between the maximum collective stop (adjustable) and the control lever. Move the pilot or co-pilot collective lever fully upward, and then try to remove the paper sheet by pulling it: the paper sheet must tear.
- 2.11 With reference to Figure 5, remove the rigging pins from the longitudinal and lateral cyclic levers.
- 2.12 In accordance with MM Paragraph 00-10-8, shut-down the hydraulic test bench and disconnect it from the helicopter.
- 2.13 In accordance with MM Paragraph 00-10-4, shut-down the electrical power unit and disconnect it from the helicopter.
3. With reference to Figure 11 and Figure 12, remove the collective control rod assy P/N 109-0032-02-41 and the tail rotor control rod assy P/N 109-0032-02-25 as follows:
 - 3.1 In accordance with MM Paragraph 25-11-9, remove the co-pilot seat.
 - 3.2 If installed, in accordance with MM Paragraph 25-21-12, remove the forward passenger seat.
 - 3.3 In accordance with the pertinent MM Paragraph, remove any other item of equipment/furnishing that might prevent the access to the work area.
 - 3.4 If installed, in accordance with MM Paragraphs 25-81-7 and 25-81-9, remove the cockpit and passenger compartment soundproofing panels or the moquette lining that might prevent the access to the inspection zone.
 - 3.5 In accordance with MM Paragraph 21-21-1, remove the air distribution duct P/N 109-0710-32-105 from the left door post.
 - 3.6 Remove the access panel P/N 109-0320-90-63.
 - 3.7 Remove the access door P/N 109-0322-10-13 on the upper part of the fuselage, over the door post.
 - 3.8 Using masking tape, identify the position and the sense of installation of each control rod assy.
 - 3.9 With reference to Figure 11, on the lower end of the collective control rod assy, remove the cotter pin, the nut, the bolt and the washers that attach the lower end of the control rod assy to the lever. Discard the cotter pin. If necessary, move slightly the collective control lever and/or

the pedals to allow an easy removal of the bolt.

CAUTION

During the hardware removing, keep the rod assy to prevent it from falling.

- 3.10 With reference to Figure 11, on the upper end of the collective control rod assy, remove the cotter pin, the nut, the bolt and the washers that attach the upper end of the control rod assy to the lever. Discard the cotter pin.

NOTE

Do not change the length of the tail rotor pitch control rod assy.

CAUTION

Apply the maximum care to prevent any damage to the control rod caused by rubbing with other parts of the helicopter.

- 3.11 Withdraw the collective control rod assy from the upper side of helicopter.
- 3.12 With reference to Figure 12, on the lower end of the tail rotor control rod assy, remove the cotter pin, the nut, the bolt and the washer that attach the lower end of the control rod assy to the lever. Discard the cotter pin.

CAUTION

During the hardware removing, keep the rod assy to prevent it from falling.

- 3.13 With reference to Figure 12, on the upper end of the tail rotor control rod assy, remove, the nut, the bolt and the washer that attach the lower end of the control rod assy to the lever. Discard the cotter pin.

NOTE

Do not change the length of the tail rotor pitch control rod assy.

CAUTION

Apply the maximum care to prevent any damage to the control rod caused by rubbing with other parts of the helicopter.

- 3.14 Withdraw the tail rotor control rod assy from the upper side of

helicopter.

4. In accordance with MM Paragraph 52-11-9, remove the pilot and co-pilot door. Open both the passenger compartment doors and lock them in opened position.
5. Remove the co-pilot door seal assy P/N 109-0360-88-109 and the passenger door seal assy P/N 109-0360-86-109. Remove any trace of adhesive and rubber from installation areas using a plastic scraper and a soft cloth moistened with solvent.
6. In accordance with MM Paragraph 25-11-9, remove the pilot seat.
7. Remove the support panels located under the pilot and co-pilot seat. Remove also the centre panel located between the seats and any control located on it (e.g. friction knob, cargo hook release handle).
8. If installed, in accordance with MM Paragraphs 67-00-12 and 67-11-9, remove the co-pilot collective control stick.
9. Set the collective control in fully-up position then lock the collective torque tube using the friction.
10. Remove the collective lever guard assy P/N 109-0700-25-127 (if the helicopter is equipped with dual control) or the fairing P/N 109-0011-28-1 (if the helicopter is not equipped with dual control).
11. Remove and retain for later re-use all the access panels located on the door sill.
12. With reference to Figure 2, remove the access panels P/N 109-0320-96-521 and P/N 109-0320-96-309 located on the post. Retain all the fixing hardware for later reuse.
13. Remove the air conditioning duct located inside the door lower sill. Cap thoroughly the open ends of the adjacent ducts to prevent any unwanted entry of foreign materials in the air conditioning system.
14. Remove the collective stick connector located on the right side of the co-pilot seat support structure. Wrap the connector using a plastic sheet and stow it in a safe place.
15. In accordance with MM Paragraphs 67-00-12 and 67-11-9, remove the collective control torque tube. To make easier the reinstallation of the torque tube at the end of the repair, it is advisable to mark the position of the following components on the torque tube using a thin felt-tip pen:
 - LVDT sensors (collective transducers);
 - Engine-out switch (if installed in accordance with SB 109EP-081);
 - Collective friction;
 - Support on the LH side of the torque tube.
16. With reference to Figure 13, remove the LH post centre fairing P/N 109-0324-29-101 by removing the related attaching screws.
17. Remove the cockpit/passenger doors caution system switch from the fairing removed at

previous Step 16 by removing the two attaching screws. Leave the switch attached to the wire. Take note of quantity of shims below the switch in order to allow the reinstallation in their original position.

18. If applied, remove any sill-liner or anti-slip paint from the upper side of the fairings P/N 109-0324-25-303 and 109-0324-30-201.
19. In accordance with MM Paragraphs 07-30-1 or 07-30-2, raise the helicopter using the lifting device P/N 109-3900-01-1 connected to a suitable crane/hoist and put the cable in tension.
20. With reference to Figure 13, remove the LH lower fairing P/N 109-0324-25-303 by drilling-out the attaching rivets. Break the sealant layer between the fairing and the structure using a thin blade or putty knife.
21. With reference to Figure 13, remove the LH post lower fairing P/N 109-0324-30-201 by drilling-out the attaching rivets. Break the sealant layer between the fairing and the structure using a thin blade or putty knife.
22. Remove any trace of sealant from the structure and from the inner side of the fairings P/N 109-0324-25-303 and 109-0324-30-201 using a plastic scraper or putty knife. Clean thoroughly using Scotch-Brite and a clean, lint-free cloth moistened with cleaning solvent MIL-PRF-680 TY II.
23. Drill-out all the rivets that attach the forward LH cap, the forward LH protection P/N 109-0311-40-133 and the doubler P/N 109-0311-40-128 (under the forward LH protection P/N 109-0311-40-133). Break the sealant layer between the cap, the protection, the doubler and the structure using a thin blade or putty knife. Remove any trace of sealant from the structure using a plastic scraper or putty knife. Clean thoroughly using Scotch-Brite and a clean, lint-free cloth moistened with cleaning solvent MIL-PRF-680 TY II.
24. If installed, remove and retain for later reuse any additional shim that is installed between the rear part of the forward LH cap and the post structure.

NOTE

For A109E helicopters from S/N 11001 thru S/N 11600
included.

25. With reference to Figure 15, temporarily remove the internal doubler, then put the new forward LH cap P/N 109-0320-90-207 or -207A1 in the same position as the removed one. If necessary, remove some rivets on the post to allow an easy positioning.

NOTE

For A109E helicopters from S/N 11601 thru S/N 11674 included.

26. With reference to Figure 15, temporarily remove the internal doubler, then put the new forward LH cap P/N 109-0320-90-507 (in the same position as the removed one. If necessary, remove some rivets on the post to allow an easy positioning.
27. In order to fit the new forward cap to the existing structure, proceed as follow:
 - 27.1 With reference to Figure 15, trim the forward end to the necessary length.
 - 27.2 With reference to Figure 20, trim the two tabs at the aft end to the necessary length and shape.
 - 27.3 With reference to Figure 22, mark and cut the round notch for the torque tube.
 - 27.4 Mark and drill some holes to temporary secure the forward LH cap to the structure.
 - 27.5 With reference to Figure 15, put in position the forward steel external protection and secure it in position in the forward part with Cleco fasteners. This allows the use the aft holes to complete the drilling of the new FWD LH cap.
 - 27.6 With reference to Figure 14, drill all the remaining holes, except the holes in the upper external side for attachment of external fairings P/N 109-0324-25-303 and 109-0324-30-201.
 - 27.7 Using the holes in the spar as a reference, drill the two Ø 6.25 mm holes for attachment of the support P/N 109-0011-18-1 of the torque tube.
28. With reference to Figure 16 thru Figure 18, find and mark the cutting line for the web P/N 109-0320-96-71. Identify and remove all the rivets that attach the web to LH angle P/N 109-0320-96-73, to forward and aft bulkhead P/N 109-0320-96, and to LH ribs P/N 109-0320-96-47 and P/N 109-0320-96-49. Using a putty knife, break the sealant/adhesive between the parts.
29. With reference to Figure 20, identify and remove the twelve additional rivets that attach the web P/N 109-0320-96-71 to the forward and aft bulkheads. They must be removed to allow installation, at the end of the repair procedure, of the external butt-strap P/N 109-0952-67-123.
30. Remove the rivets that have been identified and marked in the previous Steps 28 and 29.

NOTE

Insert a thin steel sheet between the web and the forward and aft bulkheads to avoid damages while cutting the metal.

31. With reference to Figure 17, cut the web P/N 109-0320-96-71.
32. With reference to Figure 17, identify and mark the cutting lines for angle P/N 109-0320-96-73. The slant of cut shown in figure is indicative. Always make sure that cutting lines are equally spaced from the adjacent rivets. Identify all the rivets that attach the portion of angle to other structural elements of the post.
33. With reference to Figure 17, remove the rivets identified in the previous Step 32.
34. With reference to Figure 16 and Figure 19, remove the four rivets that attach the two nut-plates to the forward side of the post. Discard the two nut-plates.
35. With reference to Figure 16 and Figure 17, cut the angle P/N 109-0320-96-73.
36. With reference to Figure 16 thru Figure 22, put the new angle P/N 109-0952-67-119, the new butt strap P/N 109-0952-67-121 and the web P/N 109-0952-67-125 in position on interior of the post. Mark the exact length of the angle P/N 109-0952-67-119, depending on the cutting position of the existing angle.
37. With reference to Figure 23 and Figure 24, mark the exact length of the internal butt-strap P/N 109-0952-67-121.

NOTE

When marking the position of the rivet holes, make sure that the distance between the hole centre and the edge of the sheet is at least 2.5 times the diameter of the rivet.

38. Remove the new angle P/N 109-0952-67-119 and the new butt strap P/N 109-0952-67-121 and cut them to the exact length as defined in Steps 36 and 37. Reinstall the items in position and mark the position of the rivet holes.
39. Drill the holes to attach the new angle P/N 109-0952-67-119, the new butt strap P/N 109-0952-67-121 and the web P/N 109-0952-67-125 to the forward bulkhead P/N 109-0320-96. Attach the parts in position with Cleco fasteners.
40. Put the web P/N 109-0952-67-125 in position on the post. Drill the holes to secure the new internal butt strap P/N 109-0952-67-121.
41. With reference to Figure 20, put the external butt-strap P/N 109-0952-67-123 in position. If necessary, adapt the shape to the profile of the post to allow the correct installation. Mark and drill the attachment holes.
42. With reference to Figure 23 and Figure 24, cut the oversize material from the external

butt-strap.

43. Remove the paint from the existing web P/N 109-0320-96-71 and from the new web P/N 109-0952-67-125 in the area of installation of the external butt-strap P/N 109-0952-67-123.
44. With reference to Figure 19 thru Figure 22, put in position the new angle P/N 109-0952-67-119, the new butt strap P/N 109-0952-67-121 and the web P/N 109-0952-67-125. Bond the internal butt-strap P/N 109-0952-67-121 with adhesive EA9309.3NA. Starting from the forward side of the post, install the rivets.
45. With reference to Figure 19 thru Figure 22, bond the external butt-strap P/N 109-0952-67-123 to the post using adhesive EA9309.3NA and rivets. Seal edges of external butt-strap P/N 109-0952-67-123 using PROSEAL 890B2.
46. With reference to Figure 19, reinstall and bond with adhesive EA9309.3NA all the shims that were installed under the lower end of forward LH bulkhead P/N 109-0320-96.

NOTE

Make sure that the rivets in the zone of installation of the torque tube support P/N 109-0011-18-1 have the countersunk head on both sides. Make sure that the head does not protrude over the surface. Flush the heads if necessary.

NOTE

For A109E helicopters from S/N 11001 thru S/N 11600 included.

47. With reference to Figure 14 and Figure 15, put the forward cap P/N 109-0320-90-207 or -207A1 in position and bond with PROSEAL 890B2. Install the forward cap using the same type of rivets as previously removed or the alternate rivets.

NOTE

For A109E helicopters from S/N 11601 thru S/N 11674 included.

48. With reference to Figure 14 and Figure 15, put the forward cap P/N 109-0320-90-507 in position and bond with PROSEAL 890B2. Install the forward cap using the same type of rivets as previously removed or the alternate rivets
49. Seal the edges of the forward LH cap using sealant PROSEAL 890B2.
50. Seal the edges of the external butt-strap P/N 109-0952-67-123 and of the web P/N 109-0952-67-125 using sealant PROSEAL 890B2.
51. With reference to Figure 19, install the two nutplates MS21071L08 and MS21069L08 in

- position. Use the collective lever guard assy P/N 109-0700-25-127 (if the helicopter is equipped with dual control) or the fairing P/N 109-0011-28-1 (if the helicopter is not equipped with dual control) to mark the position of the nutplates.
52. Temporarily put the LH post lower fairing P/N 109-0324-30-201 and the LH lower fairing P/N 109-0324-25-303 in position and drill the rivet holes in the upper part of the forward LH cap P/N 109-0320-90-207 or -207A1 or -507.
 53. Touch-up the exposed areas of the repaired zones with primer and paint to restore the original aspect.
 54. With reference to Figure 13, bond with PROSEAL 890B2 then attach with rivets the LH lower fairing P/N 109-0324-25-303. Make sure that that the drain holes in the fairing are not plugged by the sealant.
 55. With reference to Figure 13, bond with PROSEAL 890B2 then attach with rivets the LH post lower fairing P/N 109-0324-30-201. Make sure that that the drain holes in the fairing are not plugged by the sealant.
 56. In accordance with MM Paragraphs 07-30-1 or 07-30-2, lay down the helicopter.
 57. Reinstall the cockpit/passenger doors caution system switch on the LH post centre fairing P/N 109-0324-29-101 using the related screws. Put the shims (if any) in their original position.
 58. With reference to Figure 13, reinstall the LH post centre fairing P/N 109-0324-29-101 using the related attaching screws.
 59. If originally installed, reinstall the sill-liner or apply the anti-slip paint on the upper side of the fairings P/N 109-0324-25-303 and 109-0324-30-201.
 60. Reinstall the cockpit and passenger doors seals.
 61. In accordance with MM Paragraph 21-21-1, reinstall the air conditioning duct located inside the door lower sill.
 62. Reinstall the collective stick connector removed at Step 14.
 63. In accordance with MM Paragraphs 67-00-12 and 67-11-9, reinstall the collective control torque tube.
 64. With reference to Figure 11 and Figure 12, reinstall the collective control rod assy P/N 109-0032-04-41 and the tail rotor control rod assy P/N 109-0032-02-25 as follows:

CAUTION

Apply the maximum care to prevent any damage to the control rod caused by rubbing with other parts of the helicopter.

- 64.1 Put the collective control rod assy in position on interior of the left cabin post by inserting it from the top. Observe the correct sense of

- installation, as identified in previous Step 3.8
- 64.2 Attach the upper end of the collective control rod assy to the lever using the bolt AN174-12, the washer A160A0432K (under bolt head and with countersunk side toward the bolt head), the washer AN960PD416 (under the nut) and the nut MS17825-4. Torque the nut to 3.4 thru 4.5 Nm and install a new cotter pin MS24665-153.
- 64.3 Attach the lower end of the collective control rod assy to the lever using the bolt AN174-12, the washer A160A0432K (under bolt head and with countersunk side toward the bolt head), the washer AN960PD416 (under the nut) and the nut MS17825-4. If necessary, move slightly the collective control lever as necessary to allow the insertion of the bolt. Torque the nut to 3.4 thru 4.5 Nm and install a new cotter pin MS24665-153.

CAUTION

Apply the maximum care to prevent any damage to the control rod caused by rubbing with other parts of the helicopter.

- 64.1 Put the tail rotor control rod assy in position on interior of the left cabin post by inserting it from the top. Observe the correct sense of installation, as identified in previous Step 3.8
- 64.2 Attach the upper end of the tail rotor control rod assy to the lever using the bolt AN174-12, the washer AN960PD416 under the nut and the nut MS17825-4. Torque the nut to 3.4 thru 4.5 Nm and install a new cotter pin MS24665-151.
- 64.3 Attach the lower end of the tail rotor control rod assy to the lever using the bolt AN174-12, the washer AN960PD416 under the nut and the nut MS17825-4. If necessary, move slightly the pedals as necessary to allow the insertion of the bolt. Torque the nut to 3.4 thru 4.5 Nm and install a new cotter pin MS24665-151.
- 64.4 Remove the masking tape that has been put on the rods to identify the direction of installation (ref. Step 3.8).
- 64.5 Perform a duplicate inspection of installation of the control rods. The duplicate inspection must include, but is not limited to, correct assembly, security, correct application of cotter pins, thread engagement and protrusion, and a functional check for complete range, freedom of movement and operation in correct sense.

65. Repeat Step 2 to verify that the rigging of the affected flight control components has not been altered.
66. In accordance with MM Paragraph 67-21-1, perform an operational test of the collective control system, and of the tail rotor control system, to make sure that the control linkages move freely.
67. Reinstall all the access panels you have removed to perform the repair.

NOTE

For A109E helicopters from S/N 11001 thru S/N 11600
included.

68. Panel P/N 109-0320-90-7, removed at step 11, can be reused after removing thoroughly any trace of sealant using a plastic scraper and a cloth moistened with solvent MIL-PRF-680 TY II.

NOTE

For A109E helicopters from S/N 11601 thru S/N 11674
included.

69. Panel P/N 109-0320-90-505, removed at step 11, can be reused after removing thoroughly any trace of sealant using a plastic scraper and a cloth moistened with solvent MIL-PRF-680 TY II.
70. Reinstall the collective lever guard assy P/N 109-0700-25-127 (if the helicopter is equipped with dual control) or the fairing P/N 109-0011-28-1 (if the helicopter is not equipped with dual control).
71. In accordance with MM Paragraph 06-40-1, reinstall the access panels P17 and D6.
72. Reinstall the support panels located under the pilot and co-pilot seat. Reinstall also the centre panel located between the seats and any control located on it (e.g. friction knob, cargo hook release handle).
73. Reinstall the access door P/N 109-0322-10-13 on the upper part of the fuselage, over the door post, and move the platform away from helicopter.
74. Reinstall the access panel P/N 109-0320-90-63.
75. In accordance with MM Paragraph 21-21-1, reinstall the air distribution duct P/N 109-0710-32-105 on the door post.
76. With reference to the pertinent MM Paragraph, reinstall all the items of equipment/furnishing that were removed to gain access to work area.
77. If originally installed, in accordance with MM Paragraph 25-21-12, reinstall the forward passenger seat.
78. In accordance with MM Paragraph 25-11-9, reinstall the pilot and co-pilot seat.

79. If originally installed, in accordance with MM Paragraphs 25-81-7 and 25-81-9, reinstall the cockpit and passenger compartment soundproofing panels or the moquette lining.
80. In accordance with MM Paragraph 52-11-9, reinstall the pilot and co-pilot doors and close the passenger compartment doors.
81. In accordance with MM Paragraph 52-71-6, perform an operational test of the cockpit/passenger doors caution system.
82. Return the helicopter to a ready to flight condition and record for compliance with Part II of this Service Bulletin on the helicopter logbook.
83. Send the attached compliance form to the following mail box:

engineering.support.lhd@leonardo.com

As an alternative, gain access to My Communications section on Leonardo WebPortal and compile the "Service Bulletin Application Communication".

PART III

1. In accordance with MM Paragraph 00-20-1, prepare the helicopter on ground for a safe maintenance. Disconnect the battery, all electrical power sources and/or the external power supply.
2. Verify the correct rigging of the longitudinal and lateral cyclic control as follows

NOTE

The procedures shown in the paragraphs that follow must be performed, prior to removal of control rods, to assure that the rigging of the longitudinal and lateral cyclic pitch control system is correct. This will allow, after reinstallation of the control rods, to find any defect due to improper installation.

- 2.1 Put a suitable platform adjacent to the left side of the fuselage.
- 2.2 In accordance with MM Paragraph 06-40-1, remove the access panels P17 and D6.
- 2.3 In accordance with MM Paragraph 00-10-8, connect the hydraulic test bench to helicopter and operate at 1500 psi.
- 2.4 In accordance with MM Paragraph 00-10-4, connect the electrical power unit to helicopter. Apply power to AFCS system to assure the correct travel of the flight controls. Open the FORCE TRIM and AUTO TRIM circuit breakers on the overhead panel, in order to prevent the unwanted stiffening or sudden return of the flight controls at the release.
- 2.5 With reference to Figure 3 and Figure 10 find the areas of stops for collective control and install the rigging pin.

NOTE

Make sure that the rigging pin engages only the lateral cyclic lever that is located toward the rear of the helicopter.

- 2.6 With reference to Figure 9 find the area of rigging pin for lateral cyclic control system and install the rigging pin.
- 2.7 With reference to Figure 3 and Figure 4, find the areas of stops for longitudinal cyclic.
- 2.8 With reference to Figure 6, put a thin sheet of paper between the forward longitudinal cyclic master stop and the longitudinal cyclic control lever assy. Move the pilot or co-pilot cyclic stick fully forward

and try to remove the paper sheet by pulling it: the paper sheet must tear.

- 2.9 With reference to Figure 6, put another sheet of paper between the aft longitudinal cyclic master stop and the longitudinal cyclic control lever. Move the pilot or co-pilot cyclic stick fully aft and try to remove the paper sheet by pulling it: the paper sheet must tear.

NOTE

Make sure that the pin does not prevent the free operation of the lateral cyclic lever.

- 2.10 With reference to Figure 9, remove the rigging pin from the lateral cyclic lever and insert it in the hole in the forward side of support for longitudinal cyclic lever.
 - 2.11 With reference to Figure 7, put a thin sheet of paper between the left lateral cyclic master stop and the lateral cyclic lever assy. Move the pilot or co-pilot cyclic stick fully left and try to remove the paper sheet by pulling it: the paper sheet must tear.
 - 2.12 With reference to Figure 7, put another sheet of paper between the right lateral cyclic master stop and the lateral cyclic lever assy. Move the pilot or co-pilot cyclic stick fully right and try to remove the paper sheet by pulling it: the paper sheet must tear.
 - 2.13 With reference to Figure 8 and Figure 9, remove the rigging pins from the collective control lever and from the longitudinal cyclic lever.
 - 2.14 In accordance with MM Paragraph 00-10-8, shut-down the hydraulic test bench and disconnect it from the helicopter.
 - 2.15 In accordance with MM Paragraph 00-10-4 shut-down the electrical power unit and disconnect it from the helicopter.
3. With reference to Figure 25 and Figure 26, remove the lateral cyclic control rod assy P/N 109-0032-19-101 and the longitudinal cyclic control rod assy P/N 109-0032-07-01 as follows:
 - 3.1 In accordance with MM Paragraph 25-11-9, remove the pilot seat.
 - 3.2 If installed, in accordance with MM Paragraph 25-21-12, remove the forward passenger seat.
 - 3.3 In accordance with the pertinent MM Paragraph, remove any other item of equipment/furnishing that might prevent the access to the work area.
 - 3.4 If installed, in accordance with MM Paragraphs 25-81-7 and 25-81-9,

remove the cockpit and passenger compartment soundproofing panels or the moquette lining that might prevent the access to the inspection zone.

- 3.5 In accordance with MM Paragraph 21-21-1, remove the air distribution duct P/N 109-0710-32-105 from the left door post.
- 3.6 Remove the access panel 109-0320-90-206.
- 3.7 Remove the access door P/N 109-0322-10-14 on the upper part of the fuselage, over the door post.
- 3.8 Using masking tape, identify the position and the sense of installation of each control rod assy.
- 3.9 With reference to Figure 25, on the lower end of the lateral cyclic control rod assy, remove the cotter pin, the nut, the bolt and the washers that attach the lower end of the control rod assy to the lever. Discard the cotter pin. If necessary, move slightly the cyclic control stick to allow an easy removal of the bolt.

CAUTION

During the hardware removing, keep the rod assy to prevent it from falling.

- 3.10 With reference to Figure 25, on the upper end of the lateral cyclic control rod assy, remove the cotter pin, the nut, the bolt and the washers that attach the upper end of the control rod assy to the lever. Discard the cotter pin.

NOTE

Do not change the length of the tail rotor pitch control rod assy.

CAUTION

Apply the maximum care to prevent any damage to the control rod caused by rubbing with other parts of the helicopter.

- 3.11 Withdraw the rod assy toward the upper side of helicopter.
- 3.12 With reference to Figure 26, on the lower end of the longitudinal cyclic control rod assy, remove the cotter pin, the nut, the bolt and the washers that attach the lower end of the control rod assy to the lever. Discard the cotter pin.

CAUTION

During the hardware removing, keep the rod assy to prevent it from falling.

- 3.13 With reference to Figure 26, on the upper end of the longitudinal cyclic control rod assy, remove the cotter pin, the nut, the bolt and the washers that attach the upper end of the control rod assy to the lever. Discard the cotter pin.

NOTE

Do not change the length of the tail rotor pitch control rod assy.

CAUTION

Apply the maximum care to prevent any damage to the control rod caused by rubbing with other parts of the helicopter.

- 3.14 Withdraw the rod assy toward the upper side of helicopter.
4. In accordance with MM Paragraph 52-11-9, remove the pilot and co-pilot door. Open both the passenger compartment doors and lock them in opened position.
 5. Remove the pilot door seal assy P/N 109-0360-88-110 and the passenger door seal assy P/N 109-0360-86-110. Remove any trace of adhesive and rubber from installation areas using a plastic scraper and a soft cloth moistened with solvent.
 6. In accordance with MM Paragraph 25-11-9, remove the co-pilot seat.
 7. Remove the support panels located under the pilot and co-pilot seat. Remove also the centre panel located between the seats and any control located on it (e.g. friction knob, cargo hook release handle).
 8. Remove and retain for later re-use all the access panels located on the door sill
 9. With reference to Figure 2, remove the access panels P/N 109-0320-96-522 and P/N 109-0320-96-310 located on the post. Retain all the fixing hardware for later reuse.
 10. Remove the air conditioning duct located inside the door lower sill. Cap thoroughly the open ends of the adjacent ducts to prevent any unwanted entry of foreign materials in the air conditioning system.
 11. In accordance with MM Paragraphs 67-00-12 and 67-12-1, remove and retain for later reuse the following components of the flight control system:
 - Lateral cyclic control rod P/N 109-0032-01-1;
 - Lateral cyclic control rod P/N 109-0032-03-1;
 - Lateral cyclic lever P/N 109-0020-17-1;
 - Longitudinal cyclic control rod P/N 109-0032-02-1.

12. With reference to figure 13, remove the RH post centre fairing P/N 109-0324-29-102 by removing the related attaching screws.
13. Remove the cockpit/passenger doors caution system switch from the fairing removed at previous Step 12 by removing the two attaching screws. Leave the switch attached to the wire. Take note of quantity of shims below the switch in order to allow the reinstallation in their original position.
14. If applied, remove any sill-liner or anti-slip paint from the upper side of the fairings P/N 109-0324-25-304 and 109-0324-30-202.
15. In accordance with MM Paragraphs 07-30-1 or 07-30-2, raise the helicopter using the lifting device P/N 109-3900-01-1 connected to a suitable crane/hoist and put the cable in tension.
16. With reference to Figure 27, remove the RH lower fairing P/N 109-0324-25-304 by drilling-out the attaching rivets. Break the sealant layer between the fairing and the structure using a thin blade or putty knife.
17. With reference to Figure 27, remove the RH post lower fairing P/N 109-0324-30-202 by drilling-out the attaching rivets. Break the sealant layer between the fairing and the structure using a thin blade or putty knife.
18. Remove any trace of sealant from the structure and from the inner side of the fairings P/N 109-0324-25-304 and 109-0324-30-202 using a plastic scraper or putty knife. Clean thoroughly using Scotch-Brite and a clean, lint-free cloth moistened with cleaning solvent MIL-PRF-680 TY II.
19. Drill-out all the rivets that attach the forward RH cap, the forward RH protection P/N 109-0311-40-134 and the doubler P/N 109-0311-40-128 (under the forward RH protection P/N 109-0311-40-134). Break the sealant layer between the cap, the protection, the doubler and the structure using a thin blade or putty knife. Remove any trace of sealant from the structure using a plastic scraper or putty knife. Clean thoroughly using Scotch-Brite and a clean, lint-free cloth moistened with cleaning solvent MIL-PRF-680 TY II.
20. If installed, remove and retain for later reuse any additional shim that is installed between the rear part of the forward RH cap and the post structure.
21. With reference to Figure 28, temporarily remove the internal doubler, then put the new forward RH cap P/N 109-0320-90-208 or -208A1 in the same position as the removed one. If necessary, remove some rivets on the post to allow an easy positioning.
22. In order to fit the new forward cap to the existing structure, proceed as follow:
 - 22.1 With reference to Figure 28, trim the forward end to the necessary length.
 - 22.2 With reference to Figure 33 and Figure 34, trim the two tabs at the aft

- end to the necessary length and shape.
- 22.3 Mark and drill some holes to temporary secure the forward RH cap to the structure.
 - 22.4 With reference to Figure 28, put in position the forward steel external protection and secure it in position in the forward part with Cleco fasteners. This allows the use the aft holes to complete the drilling of the new FWD RH cap.
 - 22.5 With reference to Figure 28, drill all the remaining holes, except the holes in the upper external side for attachment of external fairings P/N 109-0324-25-304 and 109-0324-30-202.
23. With reference to Figure 29 thru Figure 31, find and mark the cutting line for the web P/N 109-0320-96-72. Identify and remove all the rivets that attach the web to RH angle P/N 109-0320-96-74, to forward and aft bulkhead P/N 109-0320-96, and to RH ribs P/N 109-0320-96-48 and P/N 109-0320-96-50. Using a putty knife, break the sealant/adhesive between the parts.
 24. With reference to Figure 33 and Figure 34, identify and remove the twelve additional rivets that attach the web P/N 109-0320-96-72 to the forward and aft bulkheads. They must be removed to allow installation, at the end of the repair procedure, of the external butt-strap P/N 109-0952-67-115.
 25. Remove the rivets that have been identified and marked in the previous Steps 23 and 24.

NOTE

Insert a thin steel sheet between the web and the forward and aft bulkheads to avoid damages while cutting the metal.

26. With reference to Figure 30, cut the web P/N 109-0320-96-72.
27. With reference to Figure 30, identify and mark the cutting lines for angle P/N 109-0320-96-74. The slant of cut shown in figure is indicative. Always make sure that cutting lines are equally spaced from the adjacent rivets. Identify all the rivets that attach the portion of angle to other structural elements of the post.
28. With reference to Figure 30, remove the rivets identified in the previous Step 27.
29. With reference to Figure 29 and Figure 30, cut the angle P/N 109-0320-96-74.
30. With reference to Figure 29 thru Figure 34, put the new angle P/N 109-0952-67-111, the new internal butt strap P/N 109-0952-67-113 and the web P/N 109-0952-67-109 in position on interior of the post. Mark the exact length of the angle P/N 109-0952-67-111, depending on the cutting position of the existing angle.

31. With reference to Figure 35 and Figure 36, mark the exact length of the internal butt-strap P/N 109-0952-67-113.

NOTE

When marking the position of the rivet holes, make sure that the distance between the hole centre and the edge of the sheet is at least 2.5 times the diameter of the rivet.

32. Remove the new angle P/N 109-0952-67-111 and the new butt strap P/N 109-0952-67-113 and cut them to the exact length as defined in Steps 30 and 31 above. Reinstall the items in position and mark the position of the rivet holes.
33. Drill the holes to attach the new angle P/N 109-0952-67-111, the new butt strap P/N 109-0952-67-113 and the web P/N 109-0952-67-109 to the forward bulkhead P/N 109-0320-96. Attach the parts in position with Cleco fasteners.
34. Put the web P/N 109-0952-67-109 in position on the post. Drill the holes to secure the new butt strap P/N 109-0952-67-113.
35. With reference to Figure 33 and Figure 34, put the external butt-strap P/N 109-0952-67-115 in position. If necessary, adapt the shape to the profile of the post to allow the correct installation. Mark and drill the attachment holes.
36. With reference to Figure 35 and Figure 36, cut the oversize material from the external butt-strap.
37. Remove the paint from the existing web P/N 109-0320-96-72 and from the new web P/N 109-0952-67-109 in the area of installation of the external butt-strap P/N 109-0952-67-115.
38. With reference to Figure 32 thru Figure 34, put in position the new angle P/N 109-0952-67-111, the new butt strap P/N 109-0952-67-113 and the web P/N 109-0952-67-109. Bond the internal butt-strap P/N 109-0952-67-113 with EA9309.3NA. Starting from the forward side of the post, install the rivets.
39. With reference to Figure 32 thru Figure 34, bond the external butt-strap P/N 109-0952-67-115 to the post using EA9309.3NA adhesive and rivets. Seal edges of external butt-strap P/N 109-0952-67-115 using PROSEAL 890B2.
40. With reference to Figure 32, reinstall and bond with EA9309.3NA all the shims that were installed under the lower end of forward RH bulkhead P/N 109-0320-96.

NOTE

Make sure that the rivets in the zone of installation of the torque tube support P/N 109-0011-18-1 have the countersunk head on both sides. Make sure that the head does not protrude over the surface. Flush the heads if necessary.

41. With reference to Figure 28, put the forward cap P/N 109-0320-90-208 or -208A1 in position and bond with PROSEAL 890B2. Install the forward cap using the same type of rivets as previously removed or the alternate rivets.
42. Seal the edges of the forward RH cap using sealant PROSEAL 890B2.
43. Seal the edges of the external butt-strap P/N 109-0952-67-115 and of the web P/N 109-0952-67-109 using sealant PROSEAL 890B2.
44. Temporarily put the RH post lower fairing P/N 109-0324-30-201 and the RH lower fairing P/N 109-0324-25-204 in position and drill the rivet holes in the upper part of the forward RH cap P/N 109-0320-90-208 or -208A1.
45. Touch-up the exposed areas of the repaired zones with primer and paint to restore the original aspect.
46. With reference to Figure 27, bond with PROSEAL 890B2 then attach with rivets the RH lower fairing P/N 109-0324-25-304. Make sure that the drain holes in the fairing are not plugged by the sealant.
47. In accordance with MM Paragraphs 07-30-1 or 07-30-2, lay down the helicopter.
48. Reinstall the cockpit/passenger doors caution system switch on the RH post centre fairing P/N 109-0324-29-102 using the related screws. Put the shims (if any) in their original position.
49. With reference to Figure 27, reinstall the LH post centre fairing P/N 109-0324-29-102 using the related attaching screws.
50. If originally installed, reinstall the sill-liner or apply the anti-slip paint on the upper side of the fairings P/N 109-0324-25-304 and 109-0324-30-202.
51. Reinstall the cockpit and passenger doors seals.
52. In accordance with MM Paragraphs 67-00-12 and 67-12-1, reinstall the following components of the flight control system:
 - Lateral cyclic control rod P/N 109-0032-01-1;
 - Lateral cyclic control rod P/N 109-0032-03-1;
 - Lateral cyclic lever P/N 109-0020-17-1;
 - Longitudinal cyclic control rod P/N 109-0032-02-1.
53. In accordance with MM Paragraph 21-21-1, reinstall the air conditioning duct located

inside the door lower sill.

54. With reference to Figure 25 and Figure 26, reinstall the lateral cyclic control rod assy and the longitudinal cyclic control rod assy P/N 109-0032-07-01 as follows:

CAUTION

Apply the maximum care to prevent any damage to the control rod caused by rubbing with other parts of the helicopter.

- 54.1 Put the longitudinal control rod assy in position on interior of the right cabin post by inserting it from the top. Observe the correct sense and position of installation, as identified in previous Step 3.8.
- 54.2 With reference to Figure 26, attach the upper end of the longitudinal control rod to the lever using the bolt AN174-12, one washer AN960-PD416 (under the bolt head), one washer AN90-PD416 under the nut, and the nut MS17825-4. Torque the nut to 3.4 thru 4.5 Nm and install a new cotter pin MS24665-153. If necessary, install one additional washer AN960-PD416 under the nut to obtain the correct engagement of the nut.
- 54.3 With reference to Figure 26, attach the lower end of the longitudinal control rod to the lever using the bolt AN174-12, one washer AN960-PD416 (under the bolt head), one washer AN90-PD416 under the nut, and the nut MS17825-4. If required, move slightly cyclic control stick as necessary to allow the insertion of the bolt. Torque the nut to 3.4 thru 4.5 Nm and install a new cotter pin MS24665-153. If necessary, install one additional washer AN960-PD416 under the nut to obtain the correct engagement of the nut.

CAUTION

Apply the maximum care to prevent any damage to the control rod caused by rubbing with other parts of the helicopter.

- 54.4 Put the lateral control rod assy in position on interior of the right cabin post by inserting it from the top. Observe the correct sense and position of installation, as identified in previous Step 3.8.
- 54.5 With reference to Figure 25, attach the upper end of the lateral control rod to the lever using the bolt AN174-12, one washer AN960-PD416 (under the bolt head), one washer AN90-PD416 under the nut, and the nut MS17825-4. Torque the nut to 3.4 thru 4.5 Nm and install a new

- cotter pin MS24665-153. If necessary, install one additional washer AN960-PD416 under the nut to obtain the correct engagement of the nut.
- 54.6 With reference to Figure 25, attach the lower end of the lateral control rod) to the lever using the bolt AN174-12, one washer AN960-PD416 (under the bolt head), one washer AN90-PD416 under the nut, and the nut MS17825-4. If required, move slightly cyclic control stick as necessary to allow the insertion of the bolt. Torque the nut to 3.4 thru 4.5 Nm and install a new cotter pin MS24665-153. If necessary, install one additional washer AN960-PD416 under the nut to obtain the correct engagement of the nut.
 - 54.7 Remove the masking tape that has been put on the rods to identify the direction of installation (ref. Step 3.8).
 - 54.8 Perform a duplicate inspection of installation of the control rods. The duplicate inspection must include, but is not limited to, correct assembly, security, correct application of cotter pins, thread engagement and protrusion, and a functional check for complete range, freedom of movement and operation in correct sense.
55. Repeat Step 2 to verify that the rigging of the affected flight control components has not been altered.
 56. In accordance with MM Paragraph 67-12-1, perform an operational test of the cyclic control system to make sure that the control linkages move freely.
 57. Reinstall all the access panels you have removed to perform the repair.
 58. Panel P/N 109-0320-90-8, removed at Step 8, can be reused after removing thoroughly any trace of sealant using a plastic scraper and a cloth moistened with solvent MIL-PRF-680 TY II.
 59. Reinstall the support panels located under the pilot and co-pilot seat. Reinstall also the centre panel located between the seats and any control located on it (e.g. friction knob, cargo hook release handle).
 60. Reinstall the access door P/N 109-0322-10-14 on the upper part of the fuselage, over the door post, and move the platform away from helicopter.
 61. Reinstall the access panel P/N 109-0320-90-206.
 62. In accordance with MM Paragraph 21-21-1, reinstall the air distribution duct P/N 109-0710-32-106 on the door post.
 63. With reference to the pertinent MM Paragraph, reinstall all the items of equipment/furnishing that were removed to gain access to work area.
 64. If originally installed, in accordance with MM Paragraph 25-21-12, reinstall the forward

passenger seat.

65. In accordance with MM Paragraph 25-11-9, reinstall the pilot and co-pilot seat.
66. If originally installed, in accordance with MM Paragraphs 25-81-7 and 25-81-9, reinstall the cockpit and passenger compartment soundproofing panels or the moquette lining.
67. In accordance with MM Paragraph 52-11-9, reinstall the pilot and co-pilot doors and close the passenger compartment doors.
68. In accordance with MM Paragraph 52-71-6, perform an operational test of the cockpit/passenger doors caution system.
69. Return the helicopter to a ready to flight condition and record for compliance with Part III of this Service Bulletin on the helicopter logbook.
70. Send the attached compliance form to the following mail box:

engineering.support.lhd@leonardo.com

As an alternative, gain access to My Communications section on Leonardo WebPortal and compile the "Service Bulletin Application Communication".

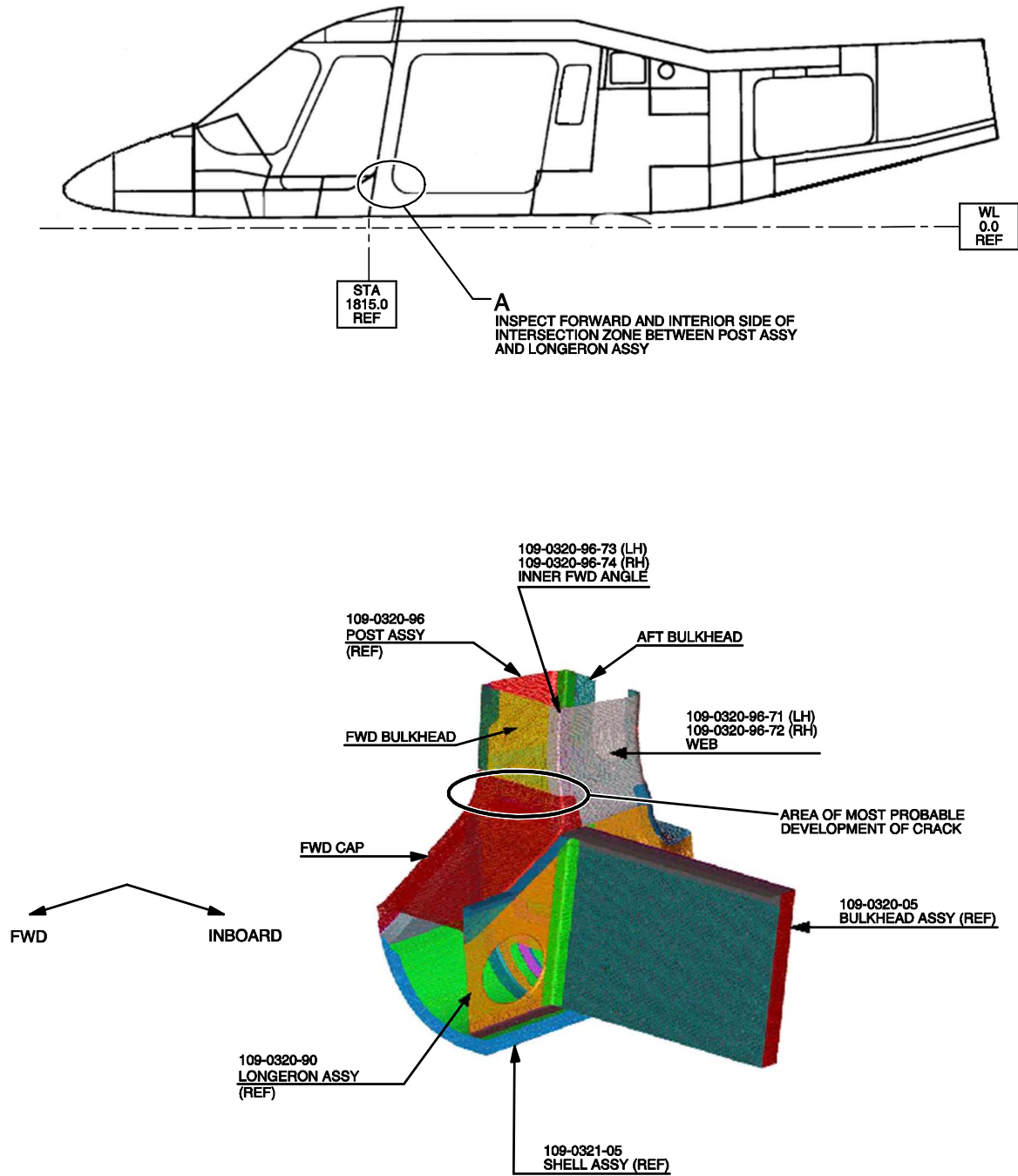

DETAIL A
RIGHT SIDE SHOWN
LEFT SIDE SYMMETRICAL
STRUCTURES AND SYSTEMS ARE PARTIALLY
OMITTED FOR BETTER CLARITY PURPOSE

Figure 1

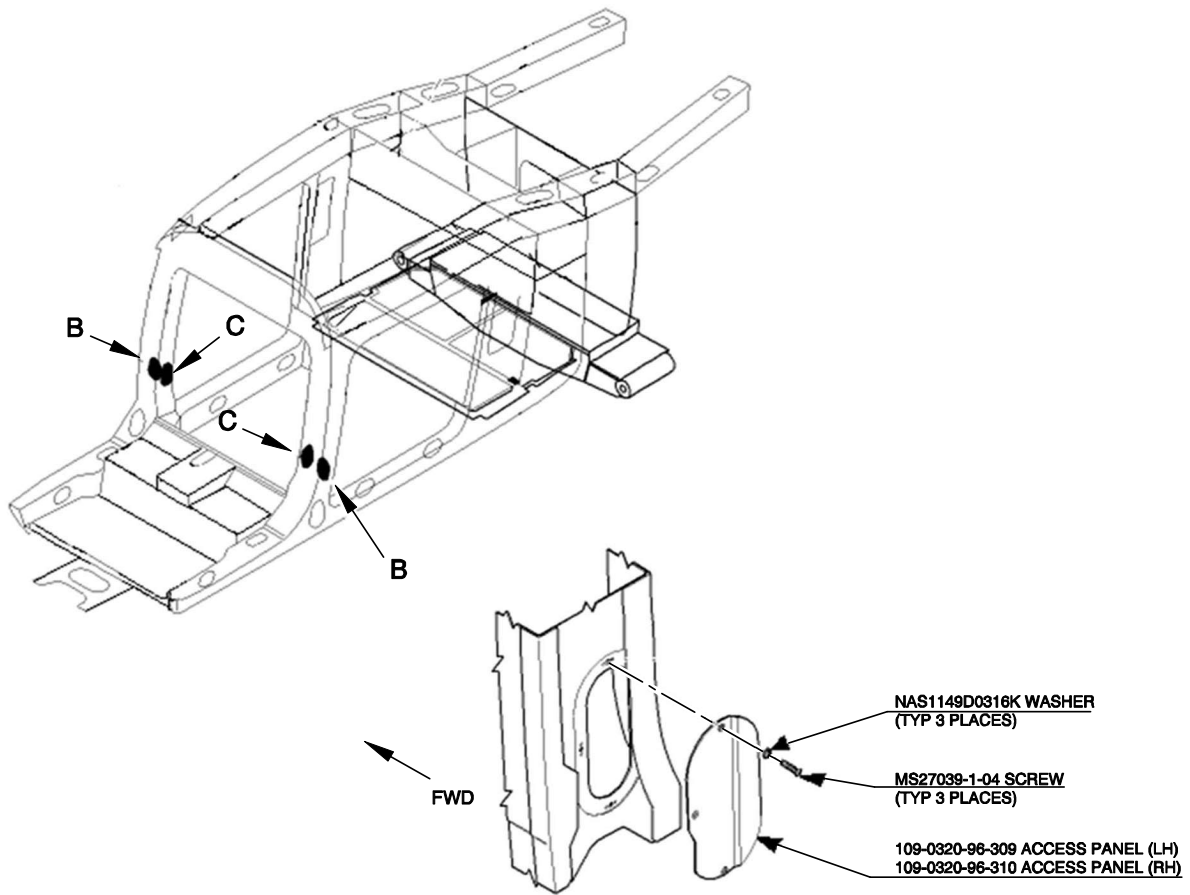

DETAIL B

STRUCTURES AND SYSTEMS ARE PARTIALLY OMITTED FOR BETTER CLARITY PURPOSE

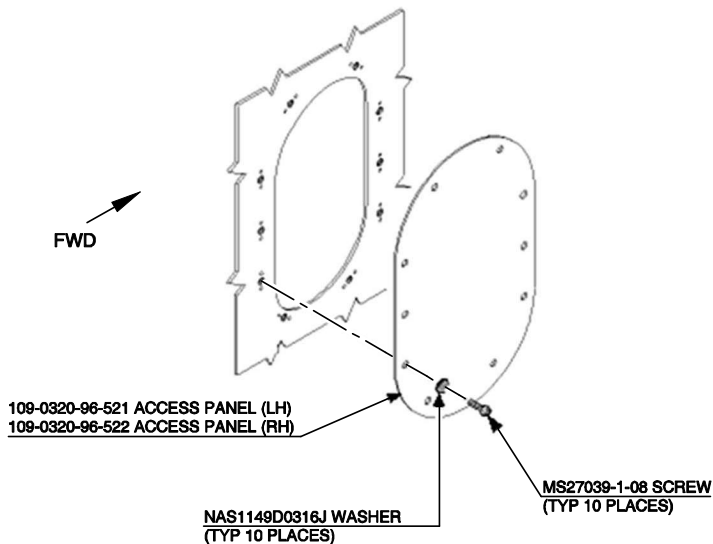

DETAIL C

STRUCTURES AND SYSTEMS ARE PARTIALLY OMITTED FOR BETTER CLARITY PURPOSE

Figure 2

S.B. N°109EP-173 ALERT
DATE: November 10, 2020
REVISION: A - July 21, 2022

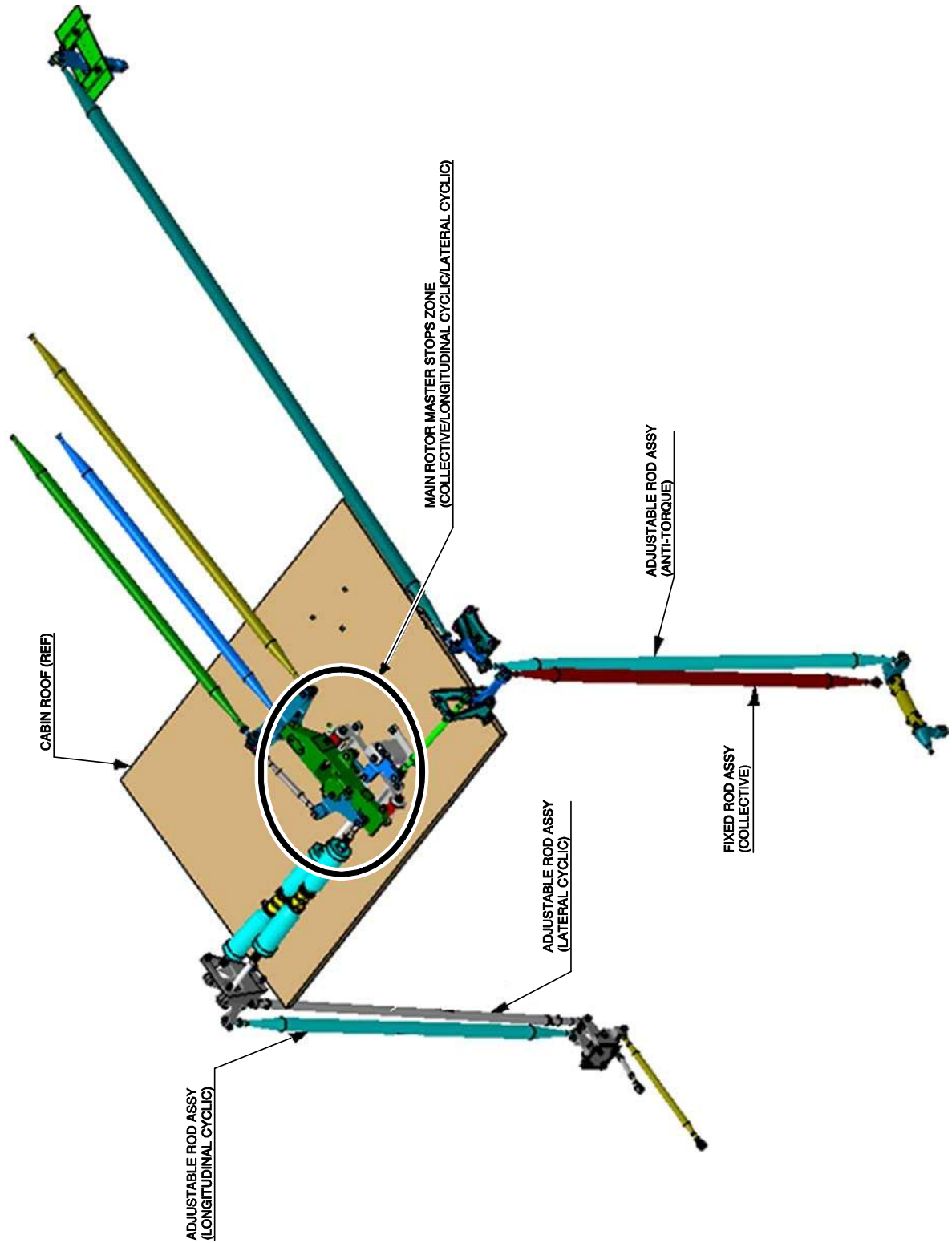

Figure 3

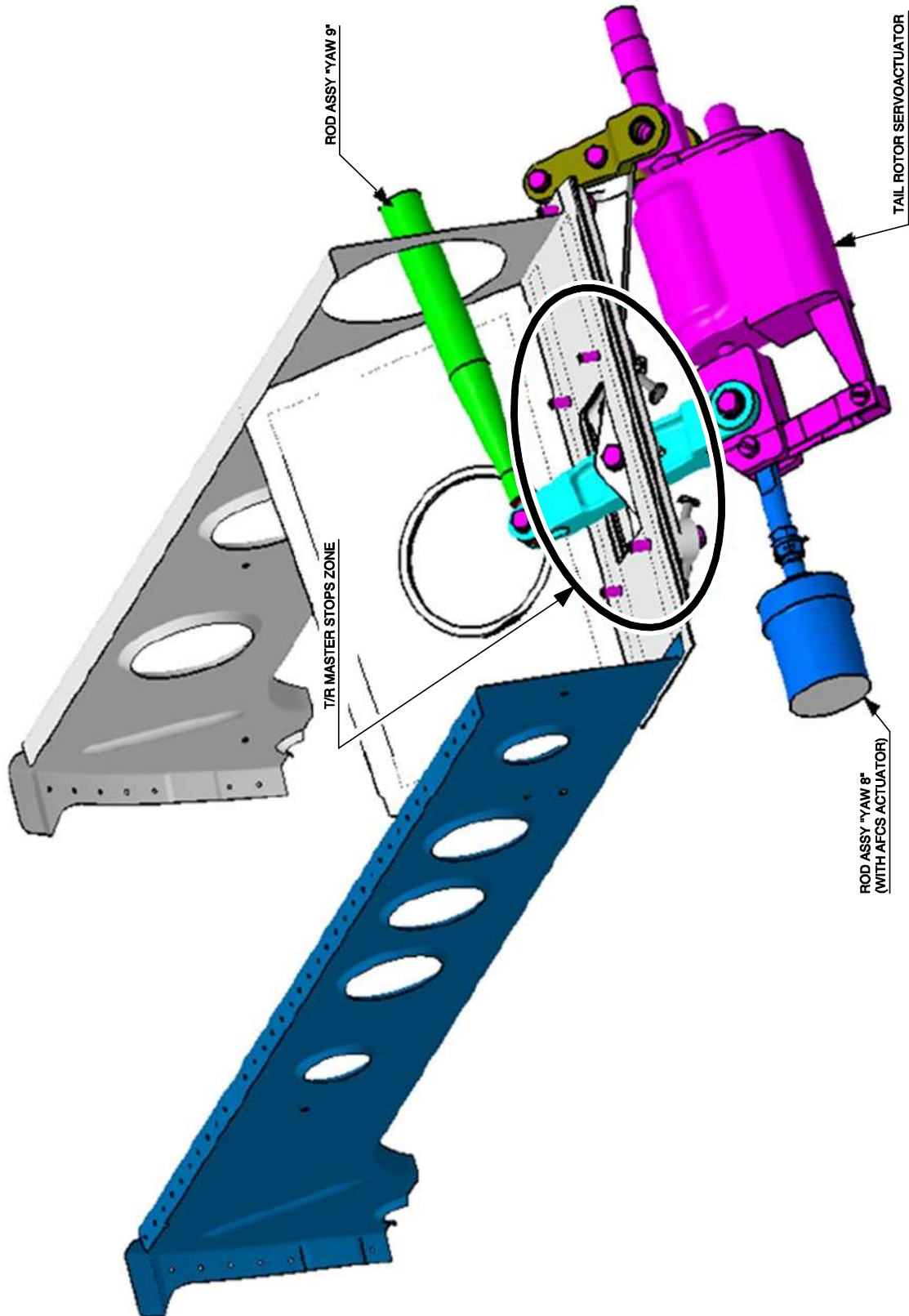

Figure 4

S.B. N°109EP-173 ALERT
DATE: November 10, 2020
REVISION: A - July 21, 2022

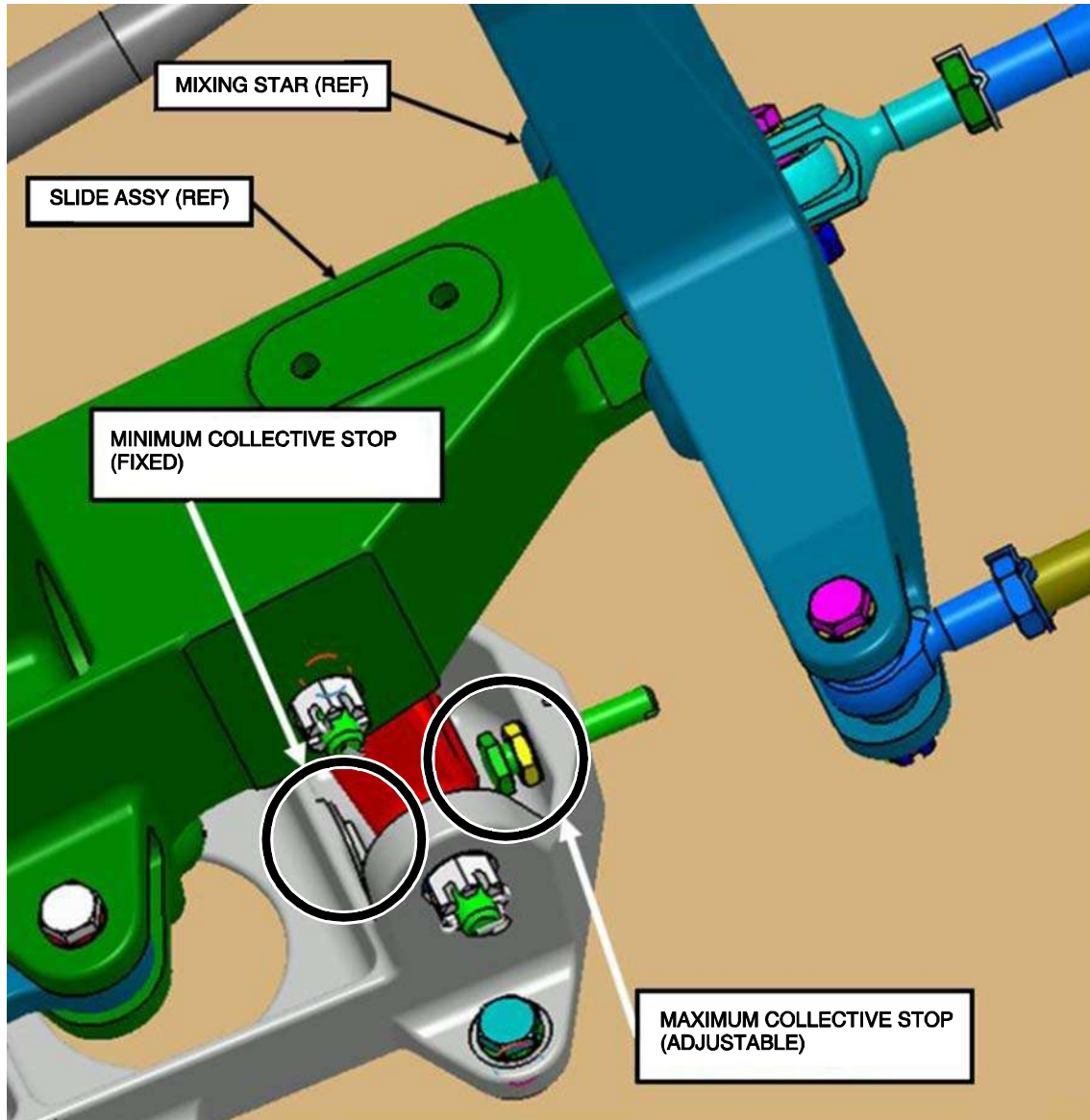

Figure 5

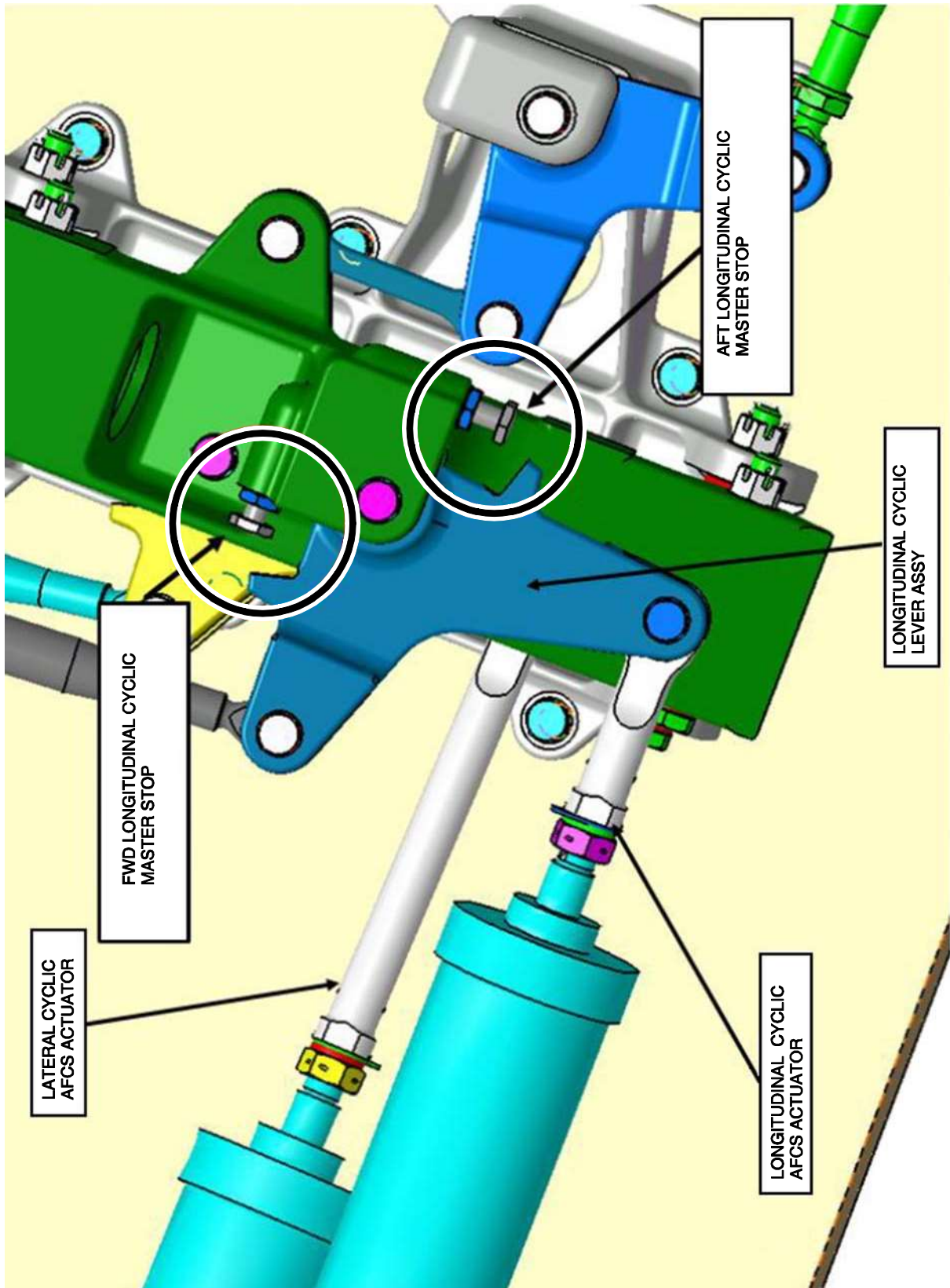

Figure 6

S.B. N°109EP-173 ALERT
DATE: November 10, 2020
REVISION: A - July 21, 2022

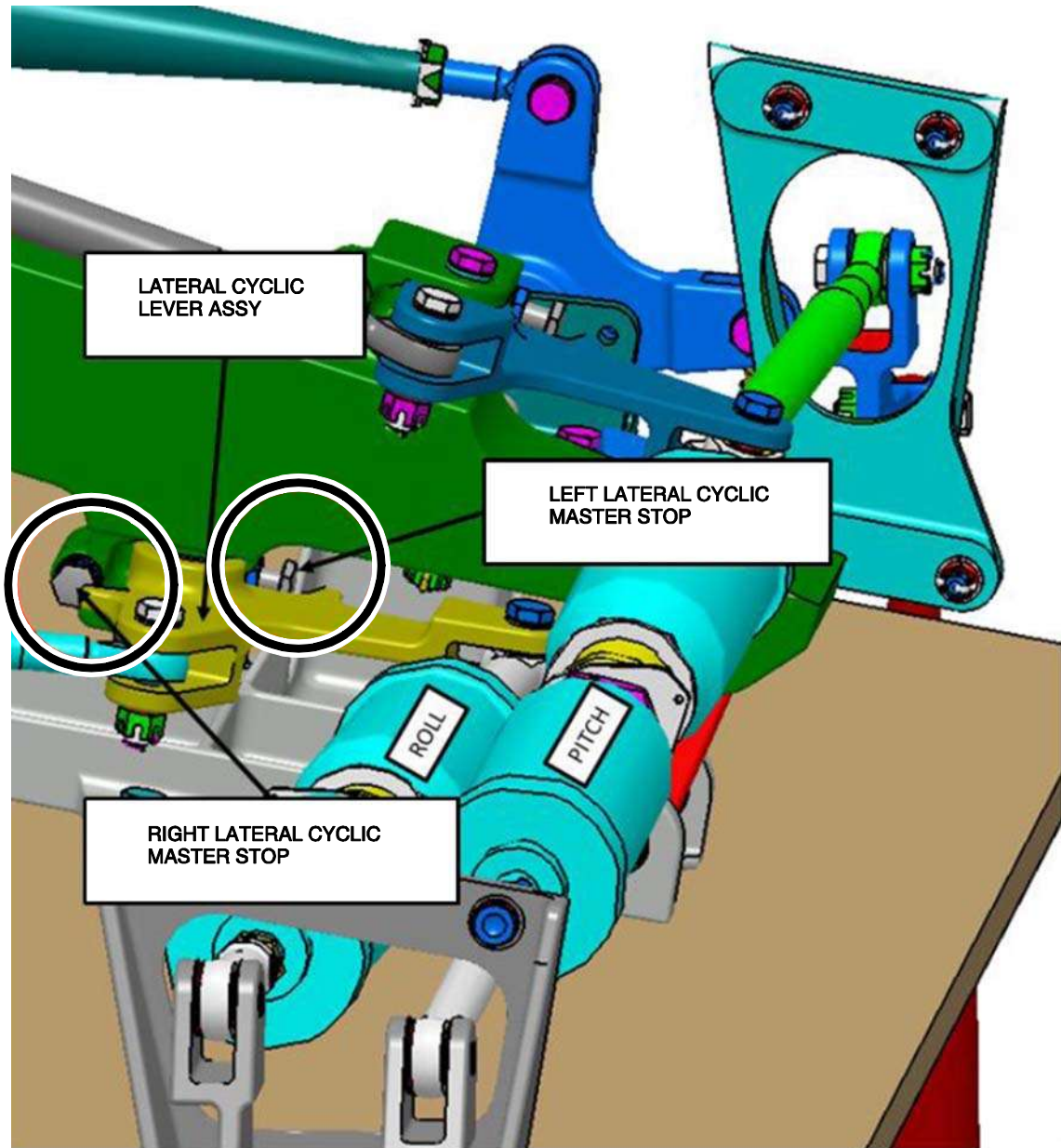

Figure 7

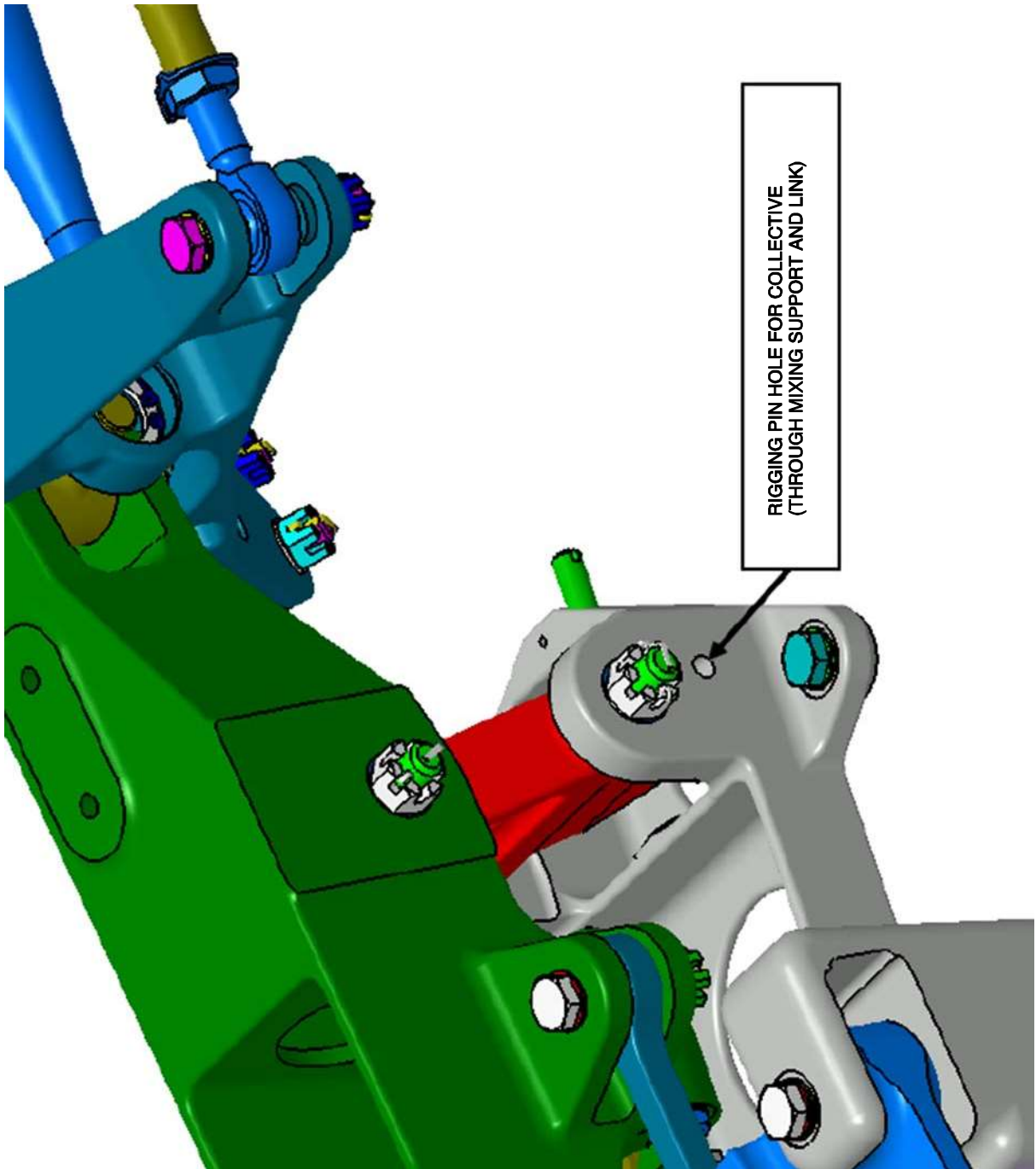

Figure 8

S.B. N°109EP-173 ALERT
DATE: November 10, 2020
REVISION: A - July 21, 2022

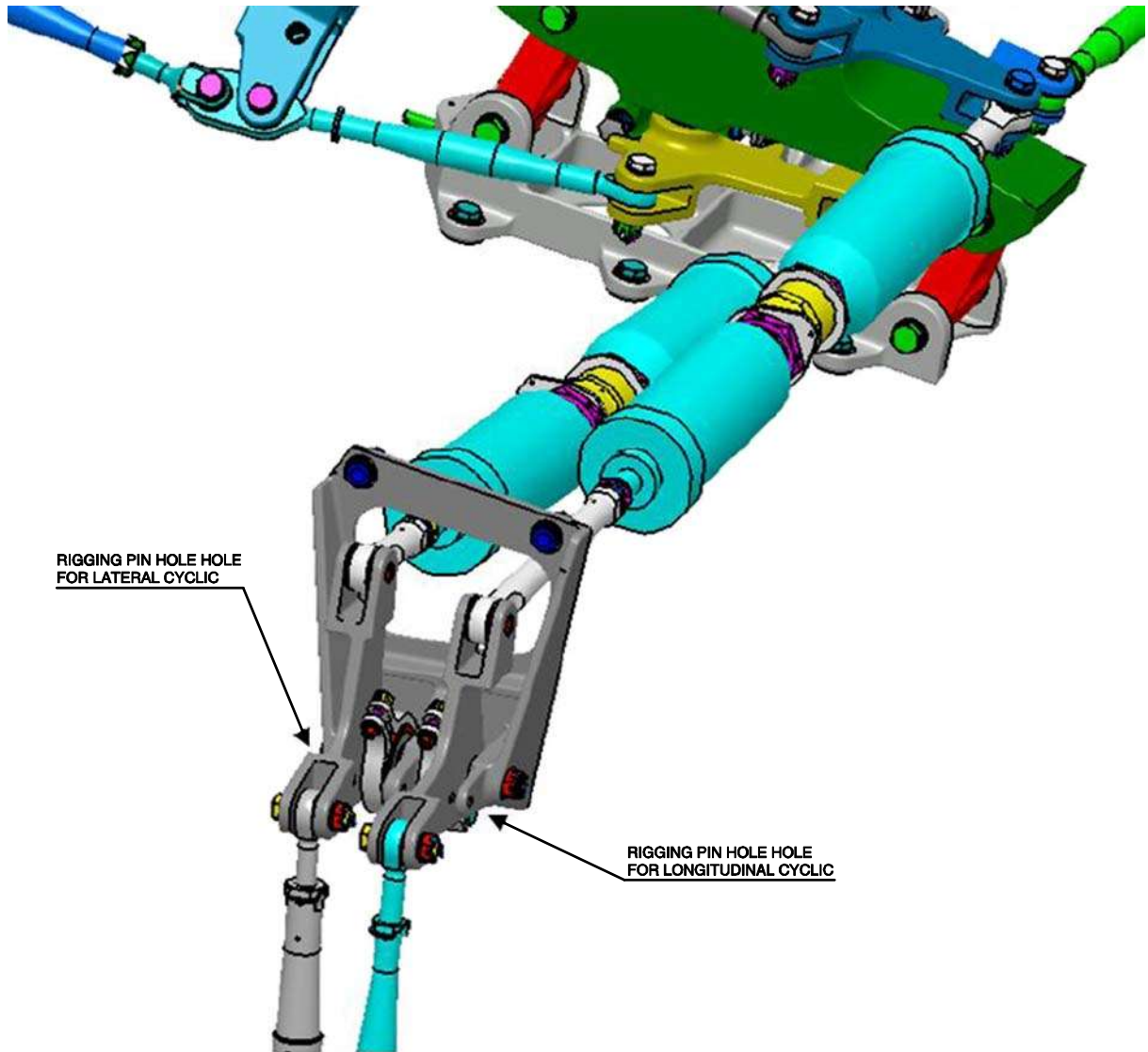

Figure 9

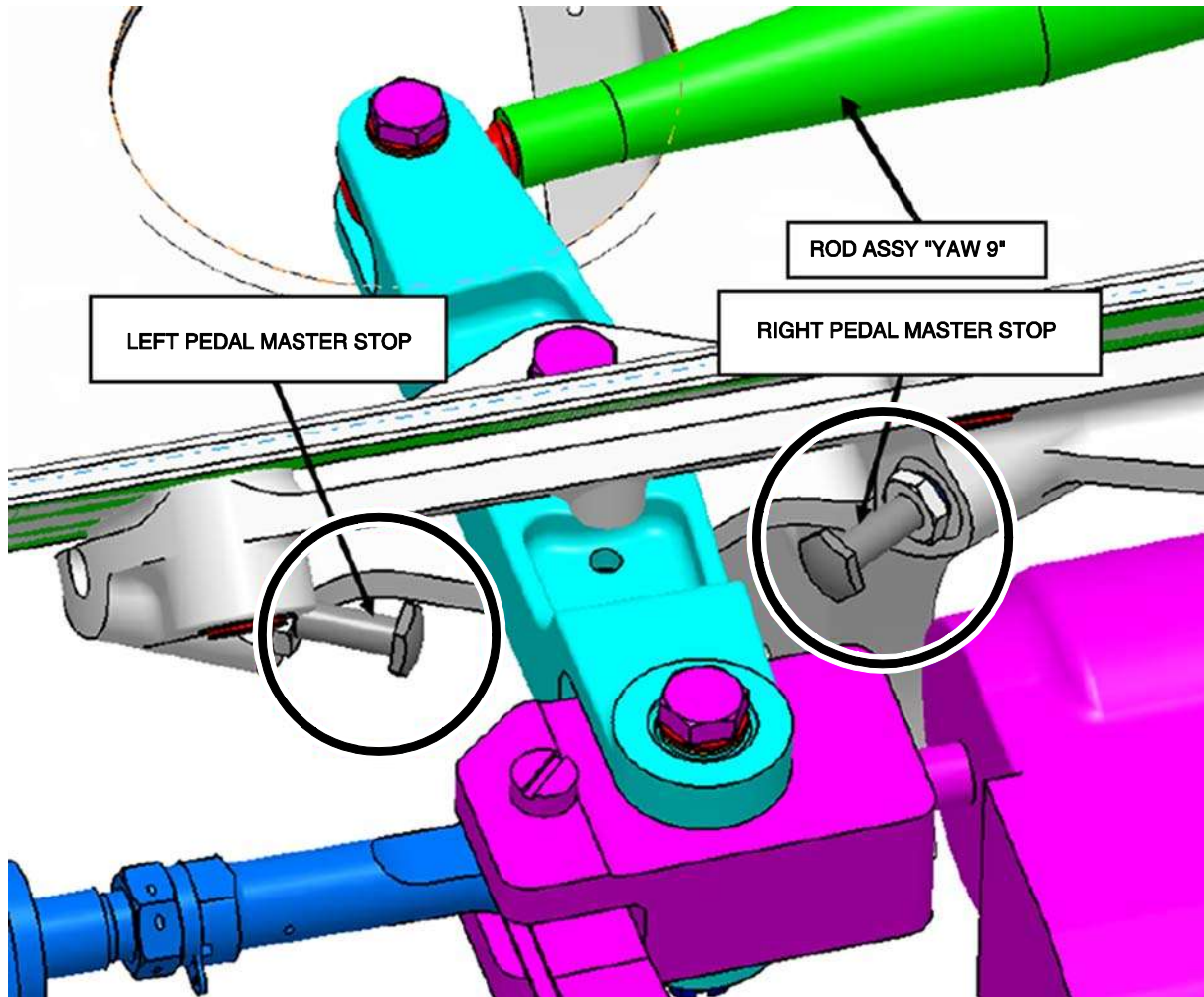

Figure 10

S.B. N°109EP-173 ALERT
DATE: November 10, 2020
REVISION: A - July 21, 2022

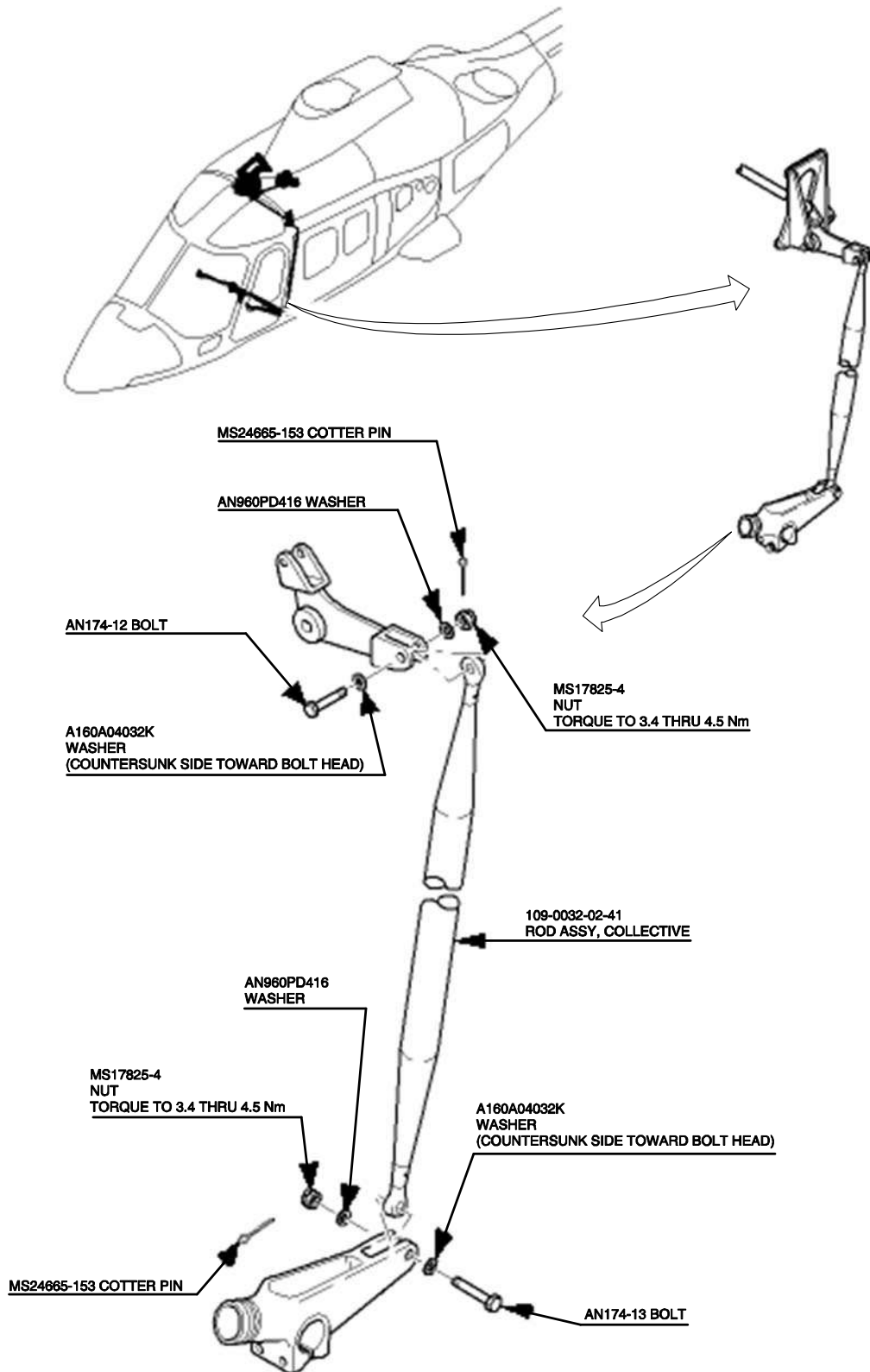

Figure 11

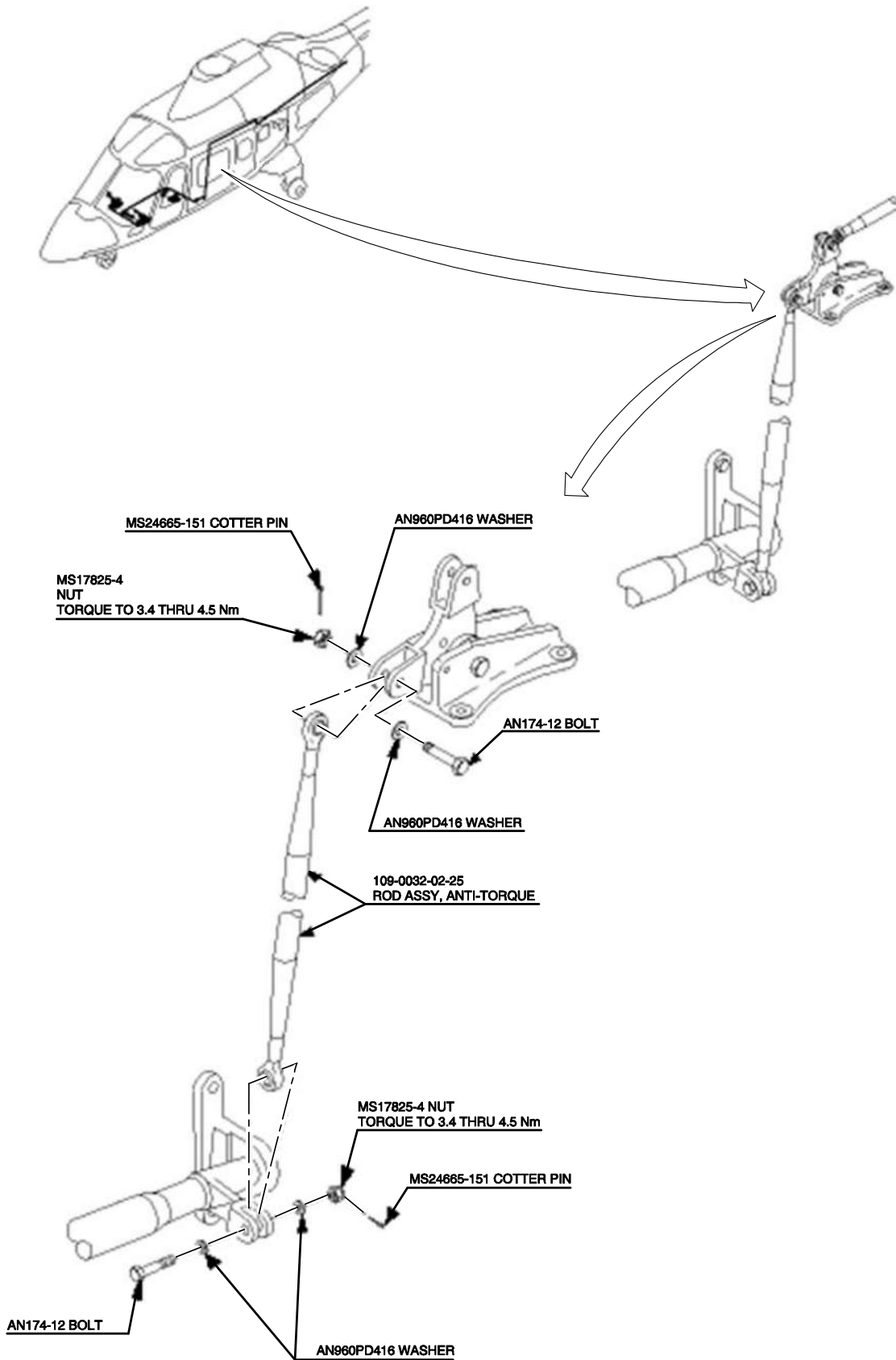

Figure 12

S.B. N°109EP-173 ALERT
DATE: November 10, 2020
REVISION: A - July 21, 2022

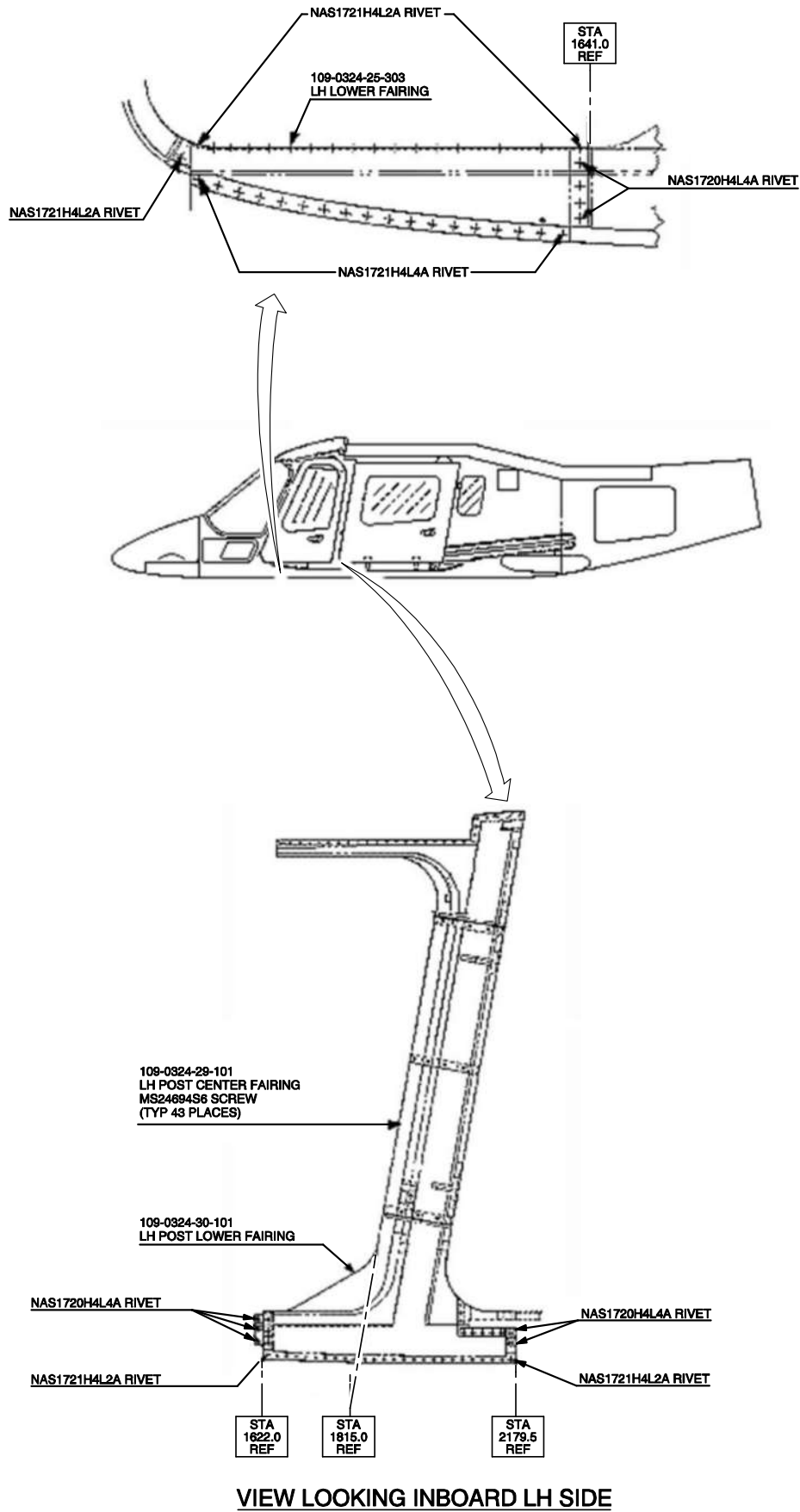

Figure 13

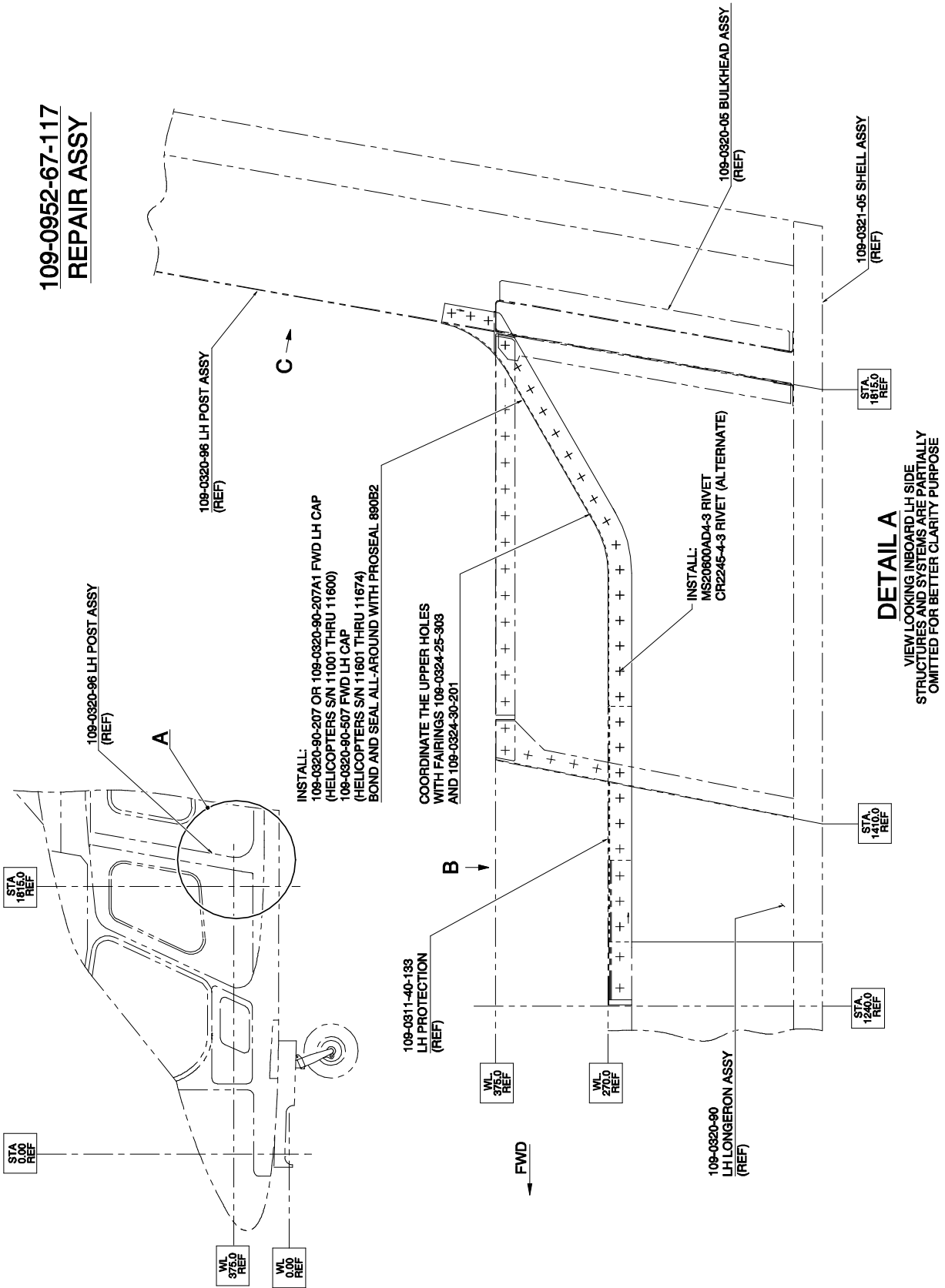
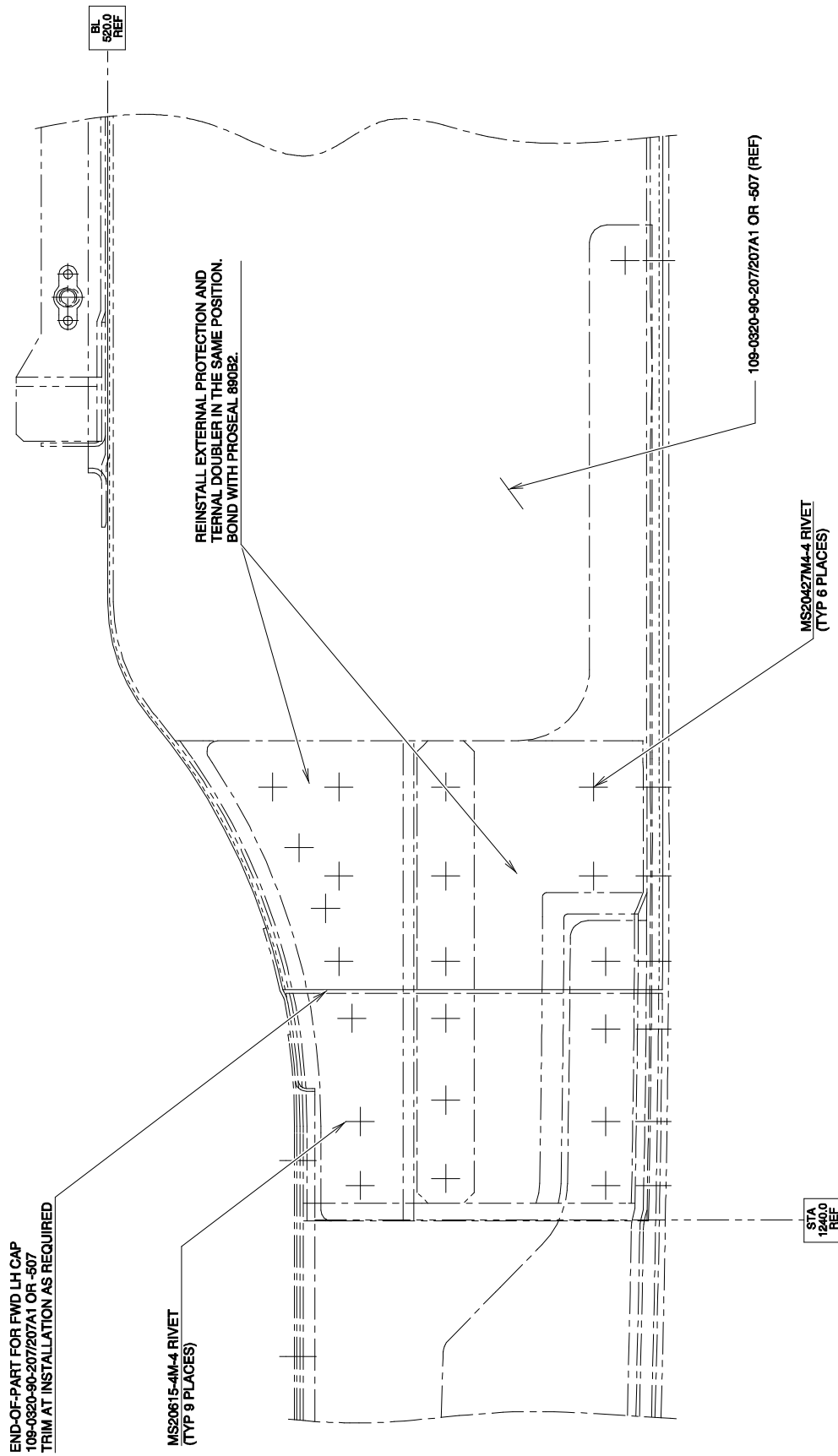

Figure 14

S.B. N°109EP-173 ALERT
DATE: November 10, 2020
REVISION: A - July 21, 2022



VIEW B
STRUCTURES AND SYSTEMS ARE PARTIALLY
OMITTED FOR BETTER CLARITY PURPOSE

Figure 15

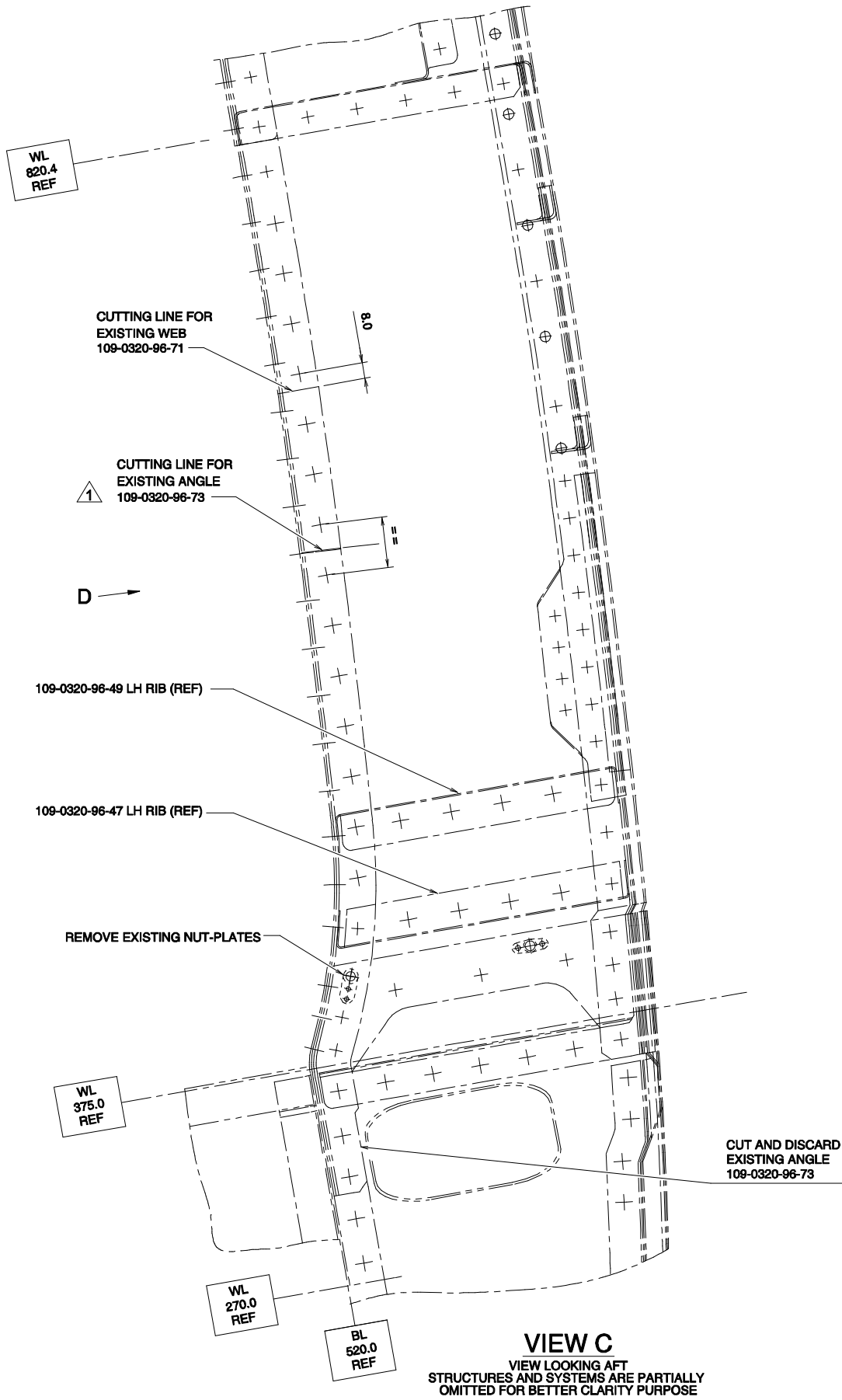
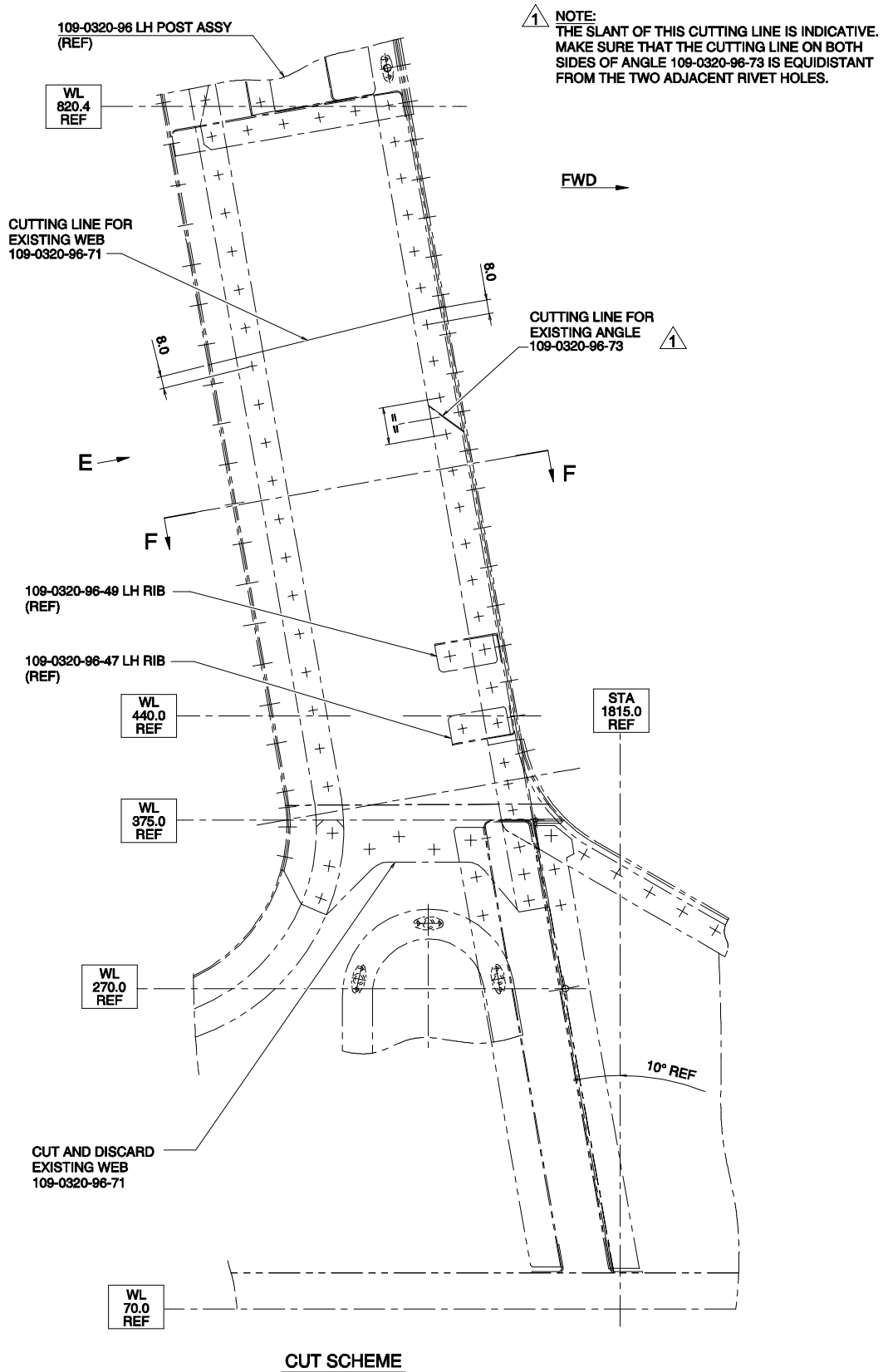

Figure 16

S.B. N°109EP-173 ALERT
DATE: November 10, 2020
REVISION: A - July 21, 2022



VIEW D

VIEW LOOKING OUTBOARD LH SIDE
STRUCTURES AND SYSTEMS ARE PARTIALLY
OMITTED FOR BETTER CLARITY PURPOSE

Figure 17

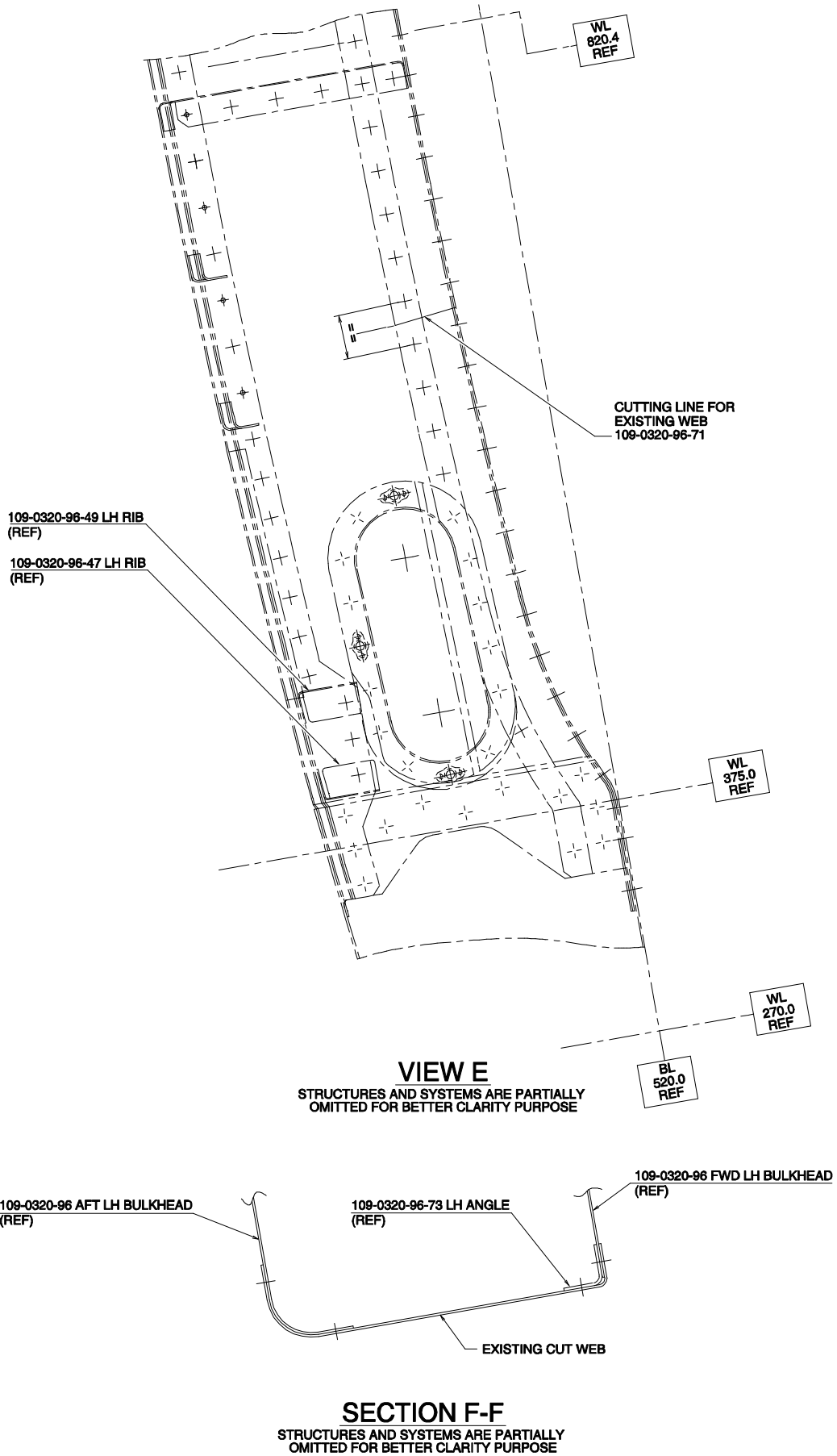
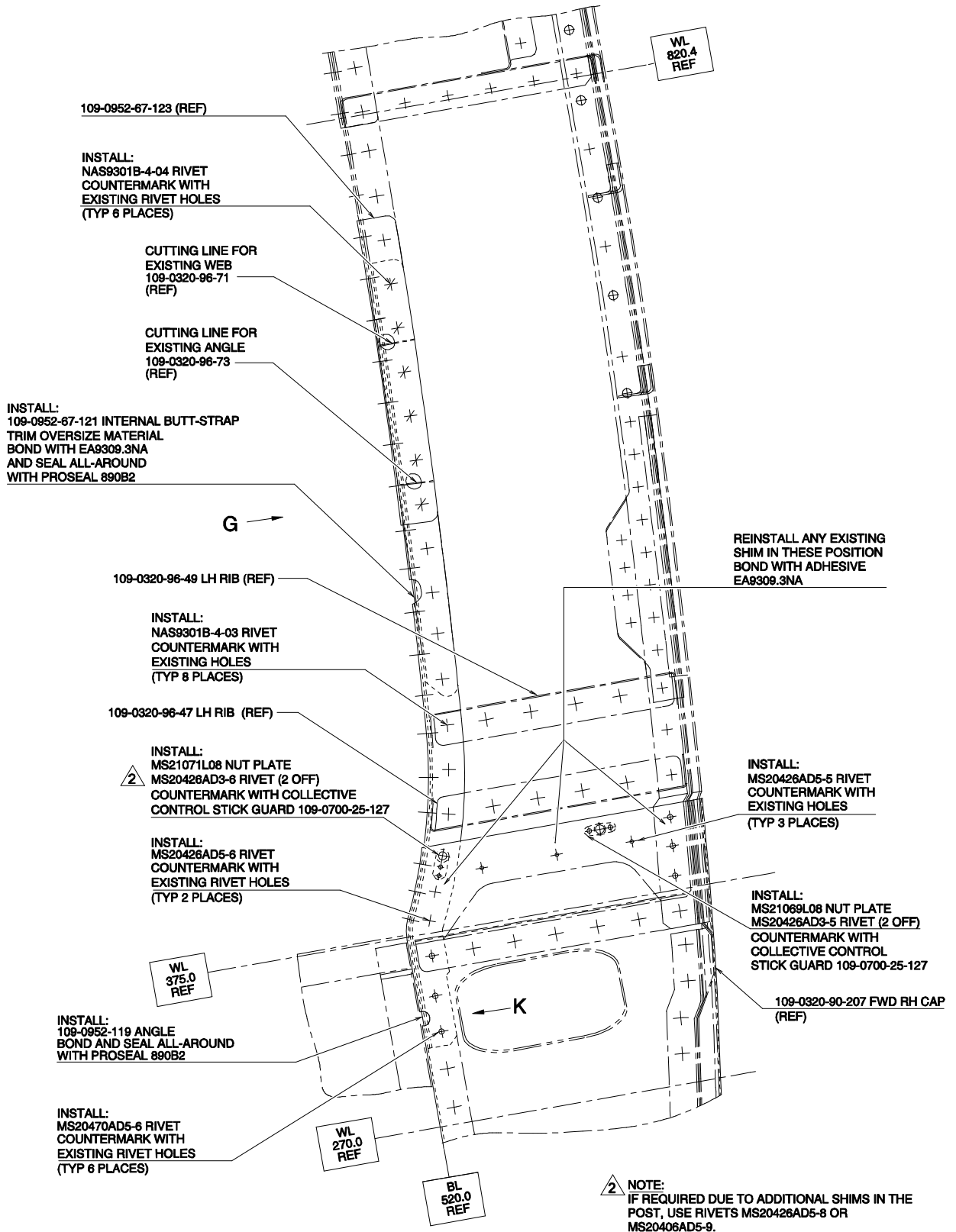

Figure 18

S.B. N°109EP-173 ALERT
DATE: November 10, 2020
REVISION: A - July 21, 2022



VIEW C

STRUCTURES AND SYSTEMS ARE PARTIALLY
OMITTED FOR BETTER CLARITY PURPOSE

Figure 19

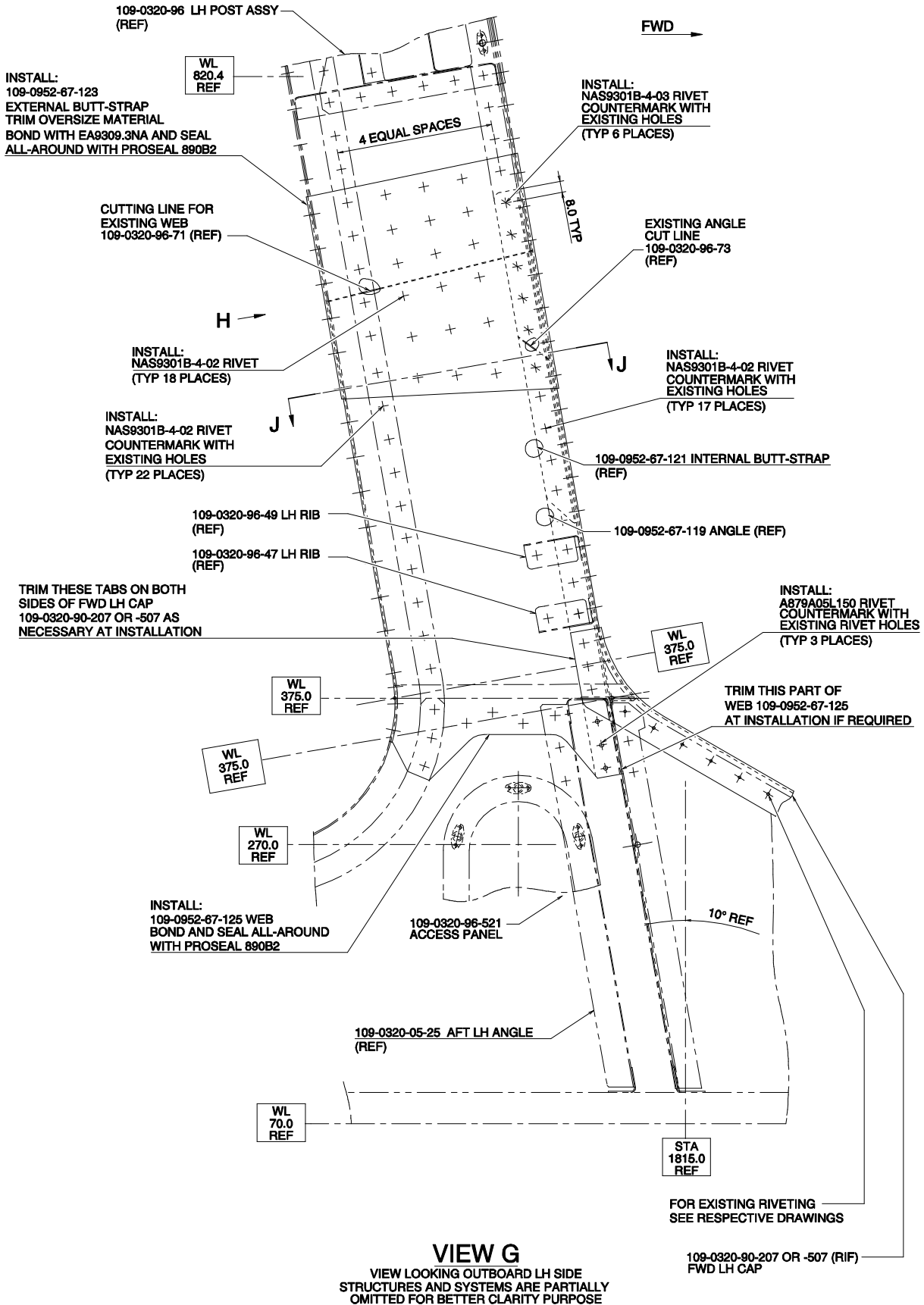

Figure 20

S.B. N°109EP-173 ALERT
DATE: November 10, 2020
REVISION: A - July 21, 2022

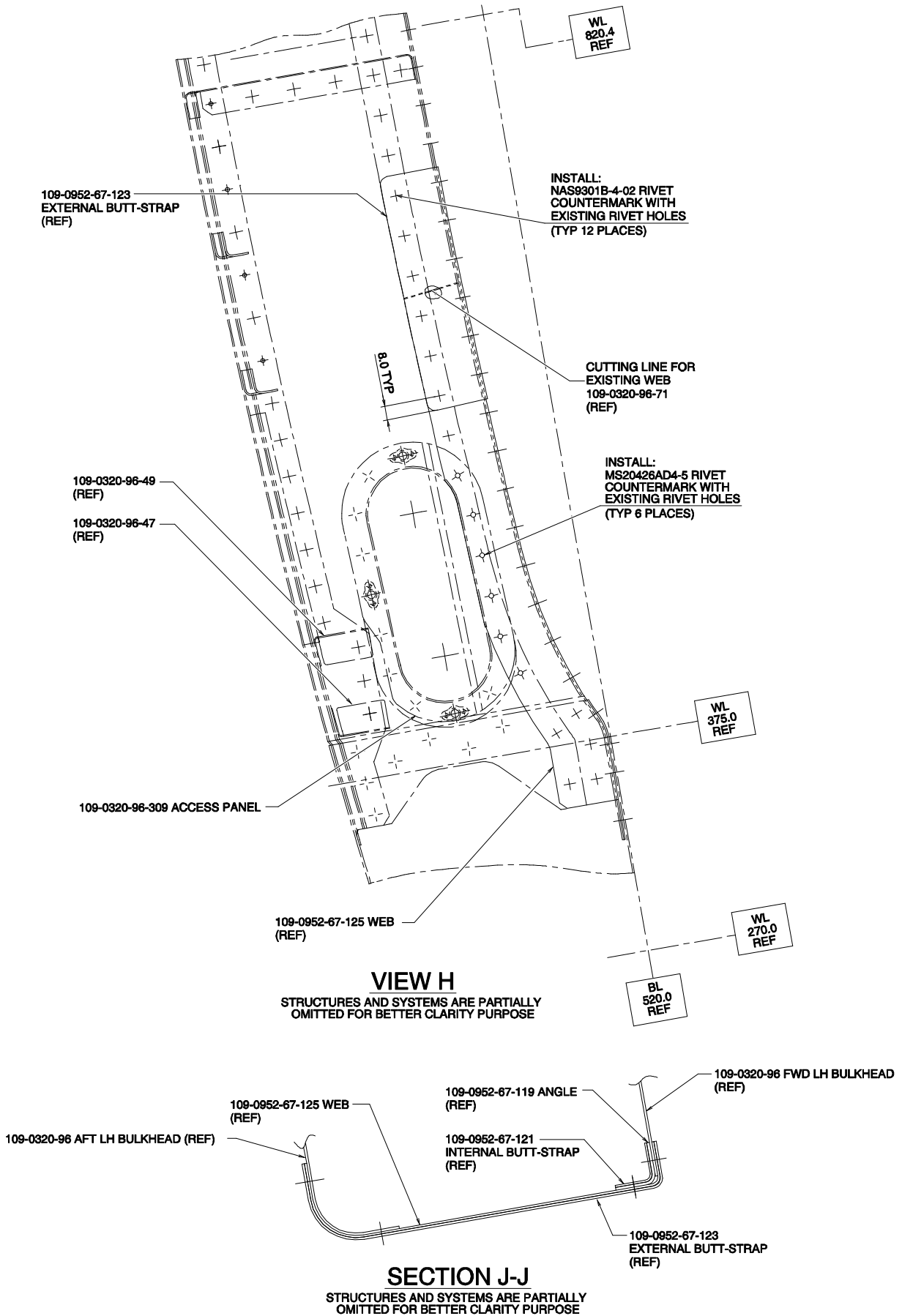
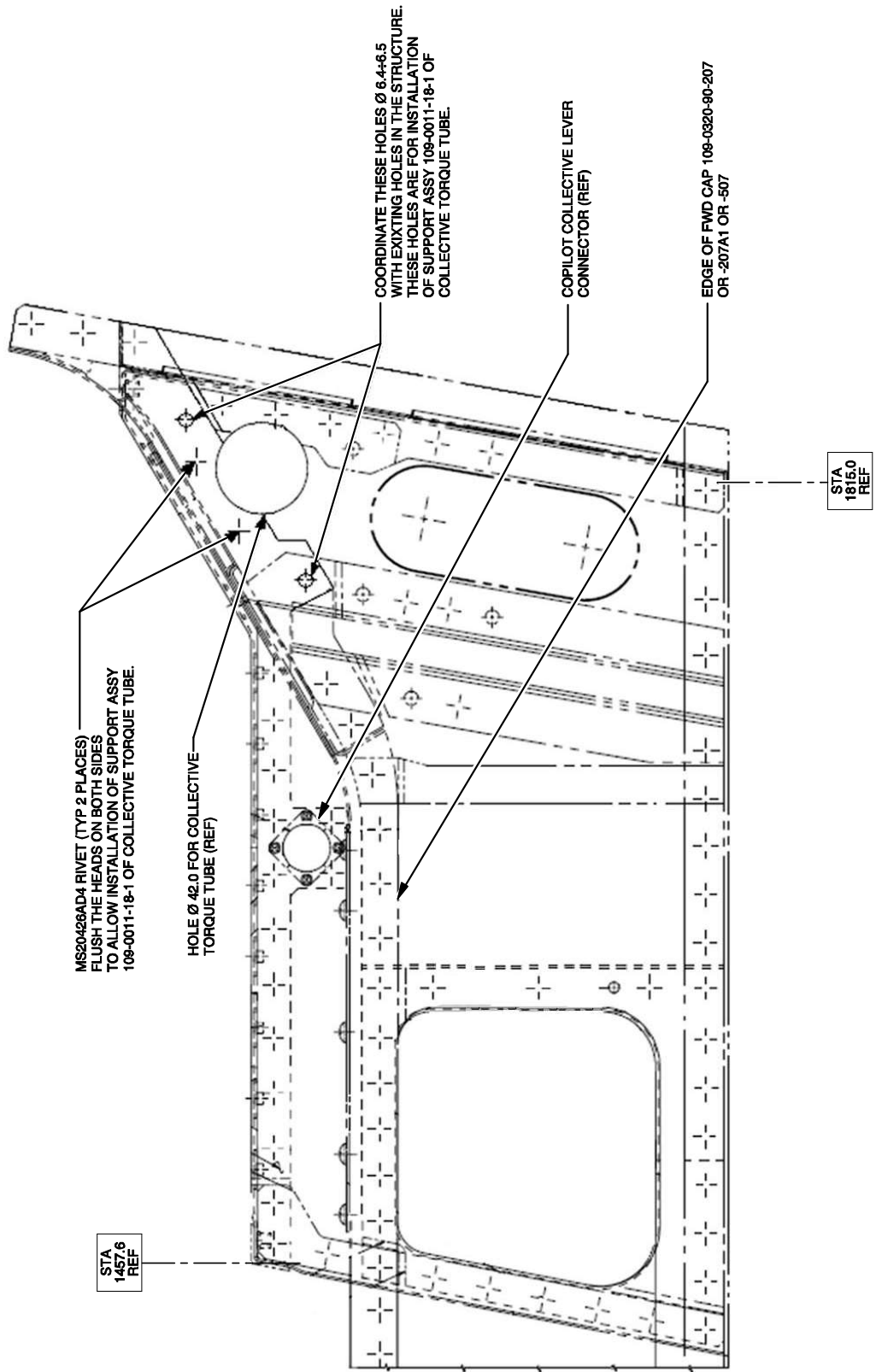

Figure 21



VIEW K
VIEW LOOKING INBOARD LH SIDE
STRUCTURES AND SYSTEMS ARE PARTIALLY
OMITTED FOR BETTER CLARITY PURPOSE

Figure 22

S.B. N°109EP-173 ALERT
DATE: November 10, 2020
REVISION: A - July 21, 2022

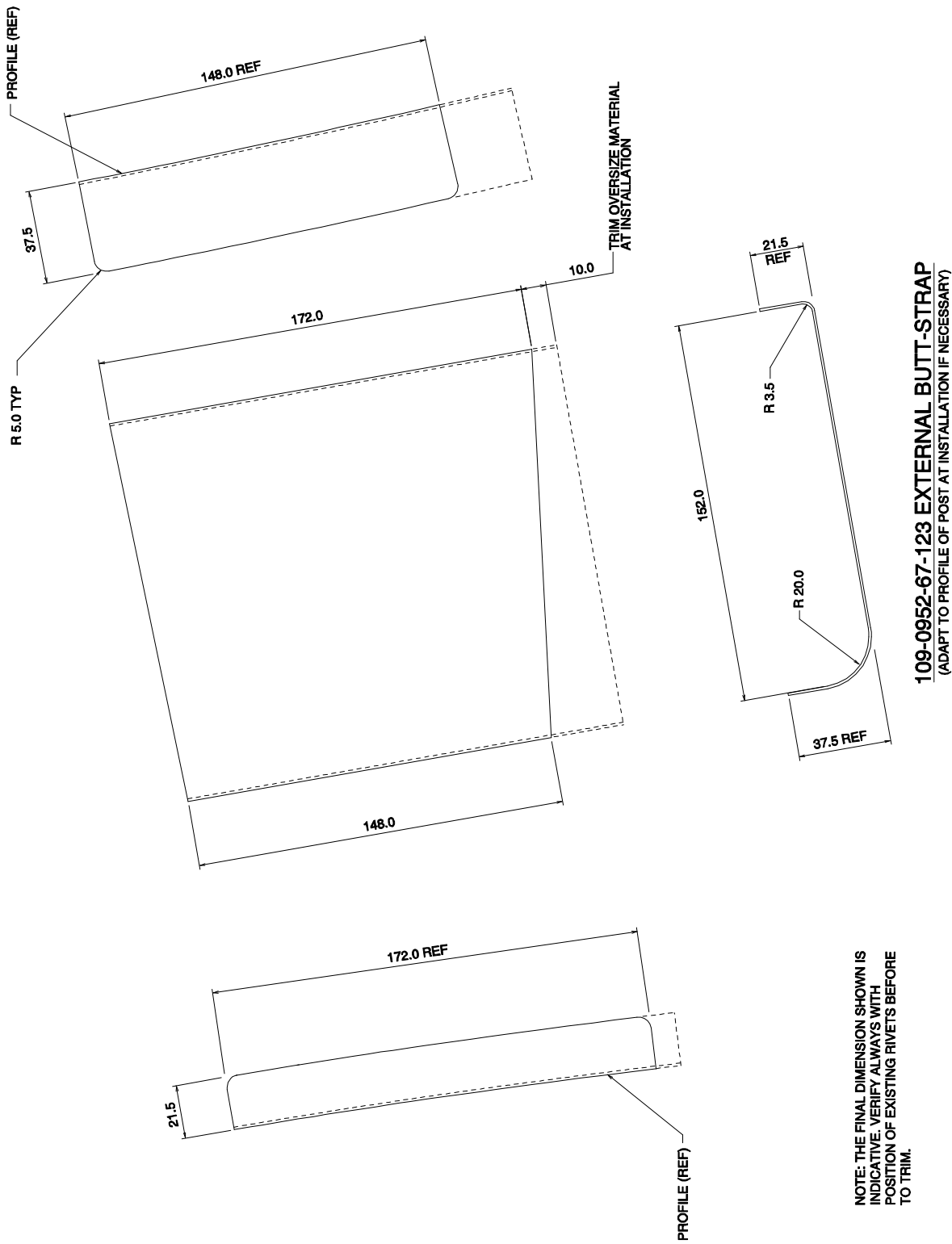
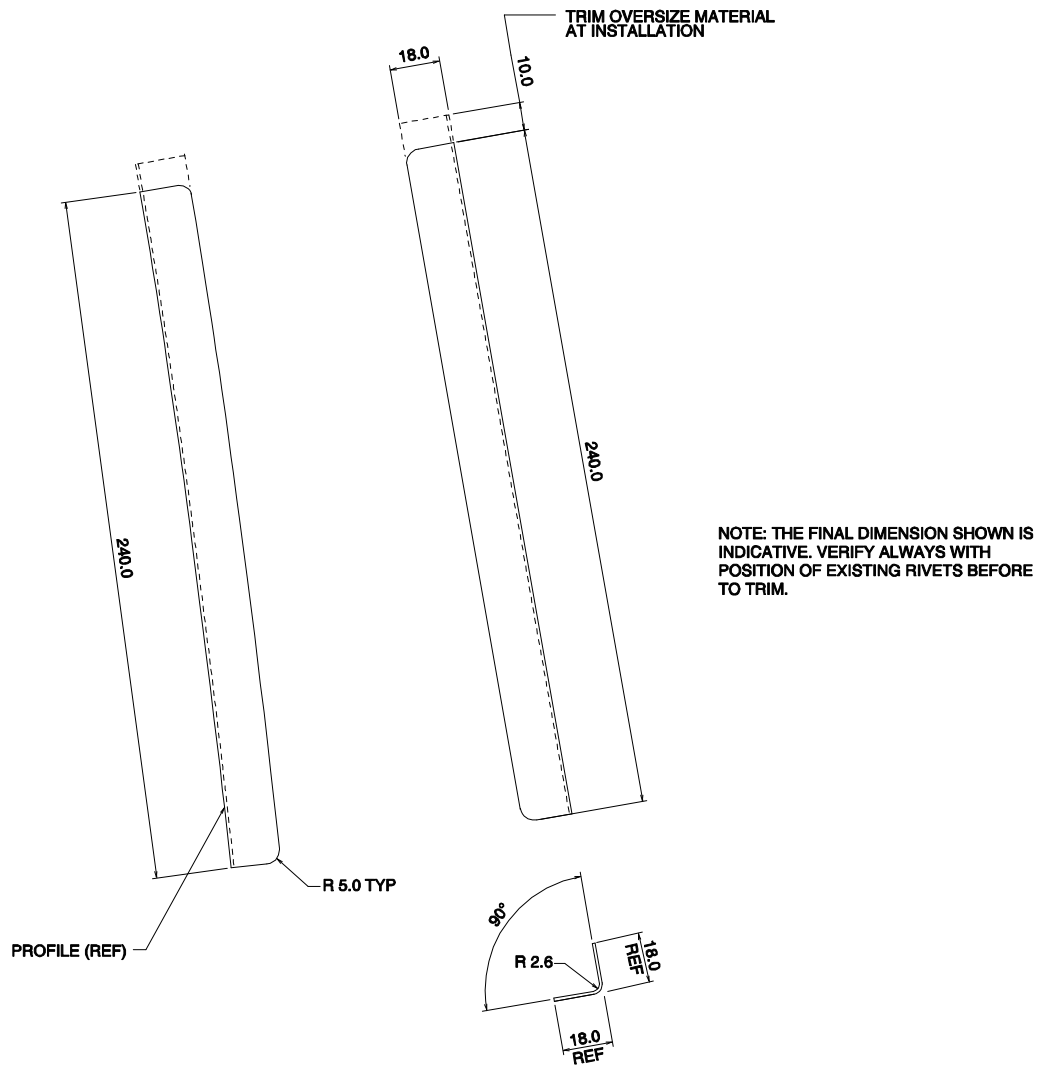
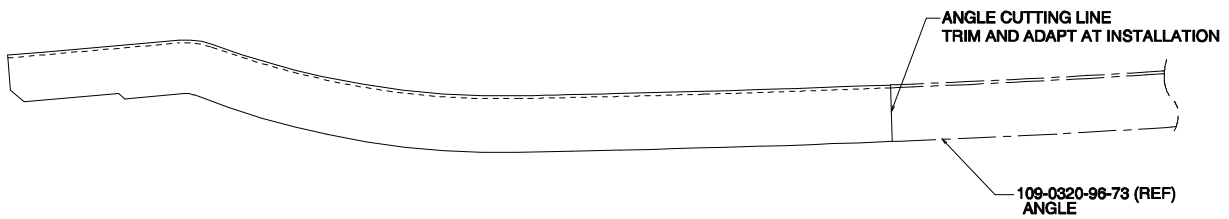

Figure 23



109-0952-67-121 INTERNAL BUTT-STRAP
(ADAPT TO PROFILE OF POST AT INSTALLATION IF NECESSARY)



109-0952-67-119 ANGLE
(REWORK FROM ANGLE)

Figure 24

S.B. N°109EP-173 ALERT
DATE: November 10, 2020
REVISION: A - July 21, 2022

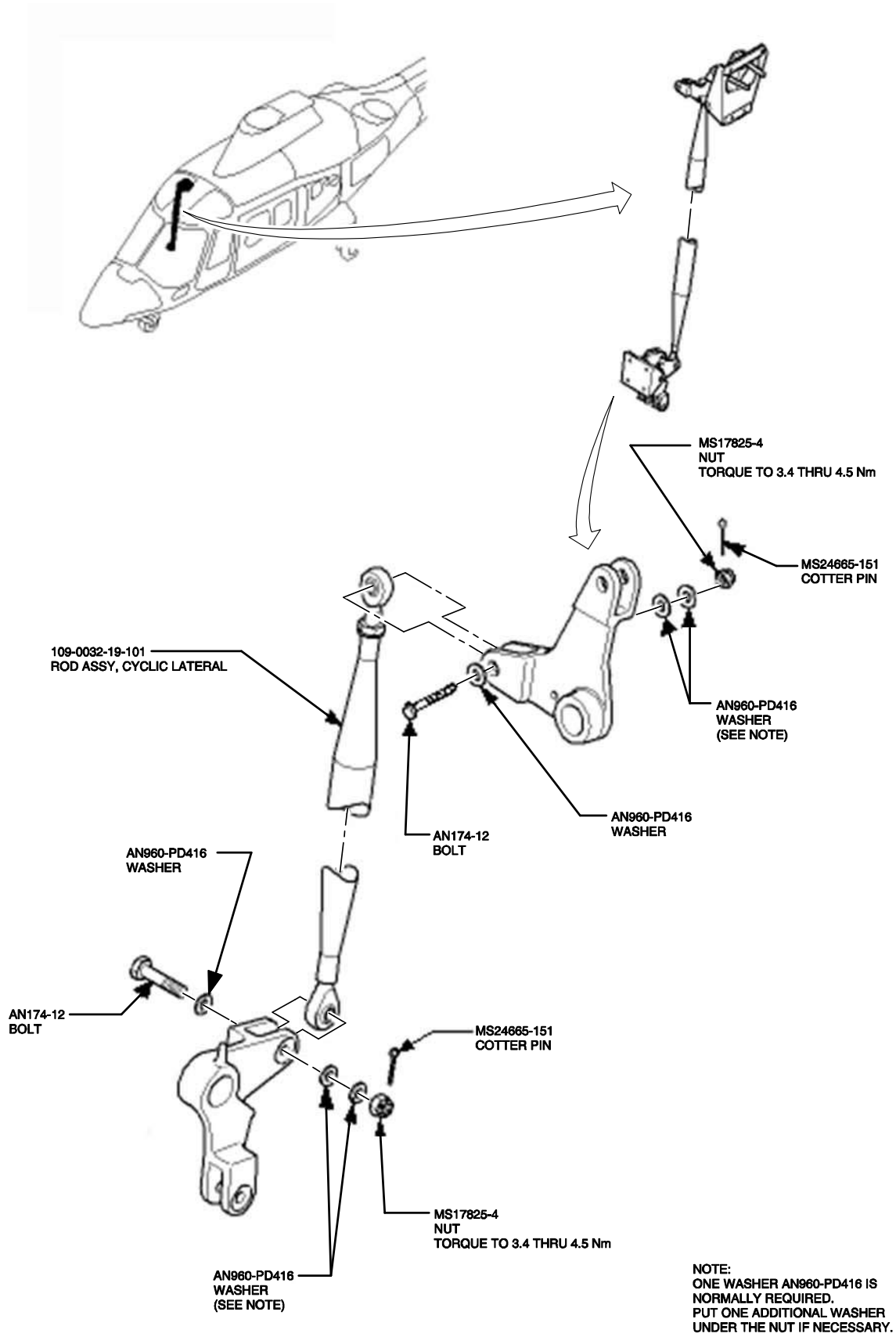

Figure 25

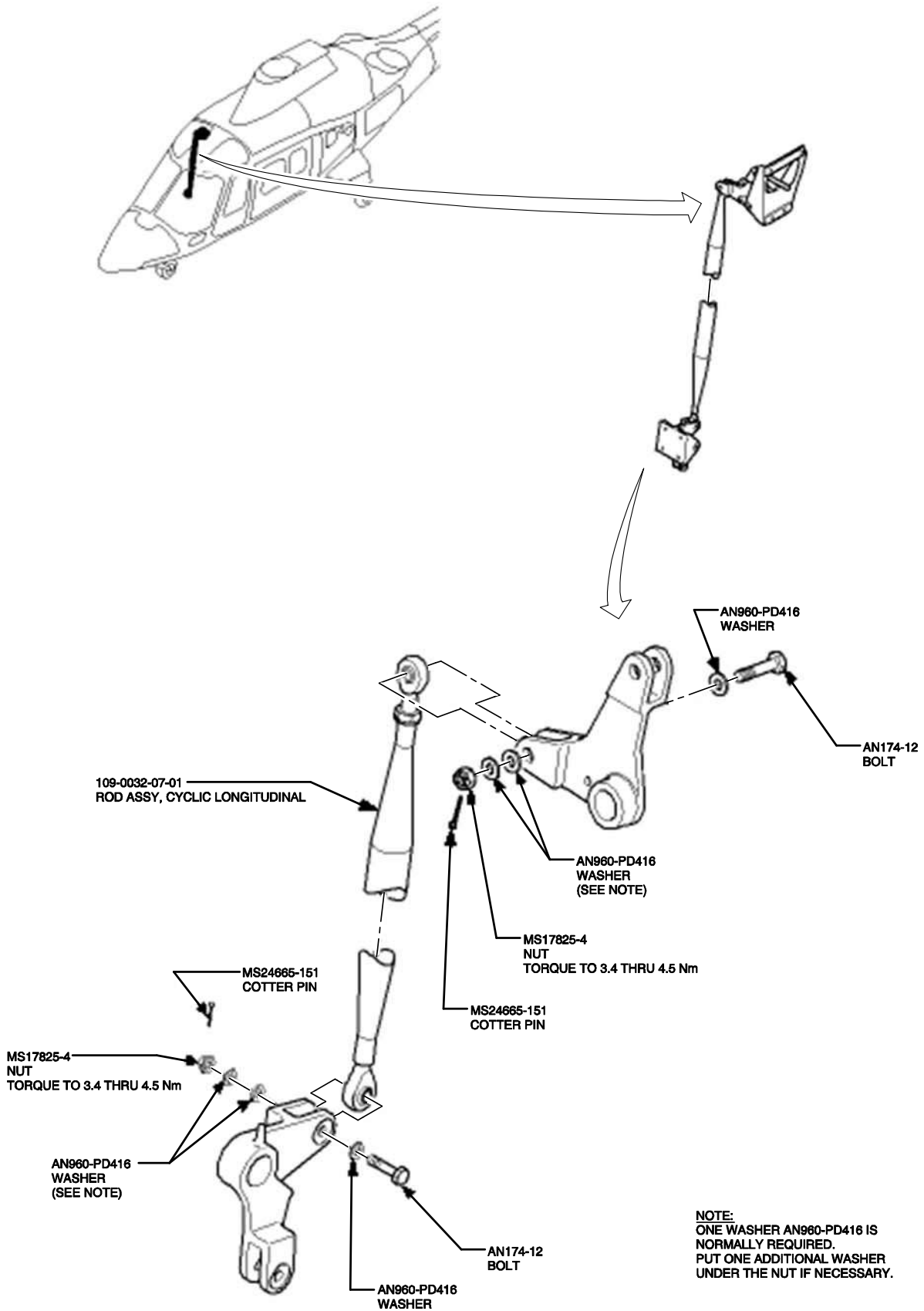

Figure 26

S.B. N°109EP-173 ALERT
DATE: November 10, 2020
REVISION: A - July 21, 2022

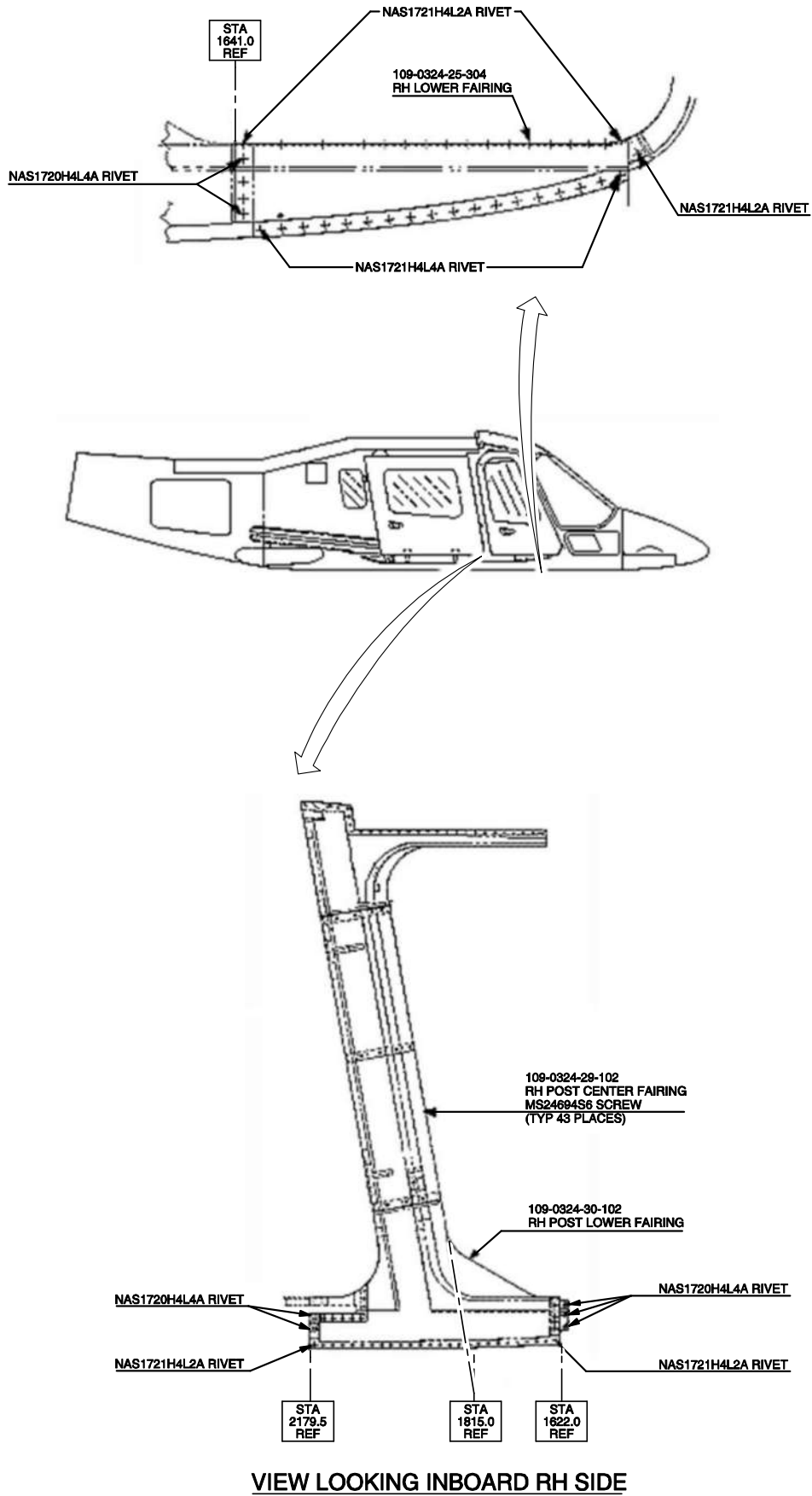

Figure 27

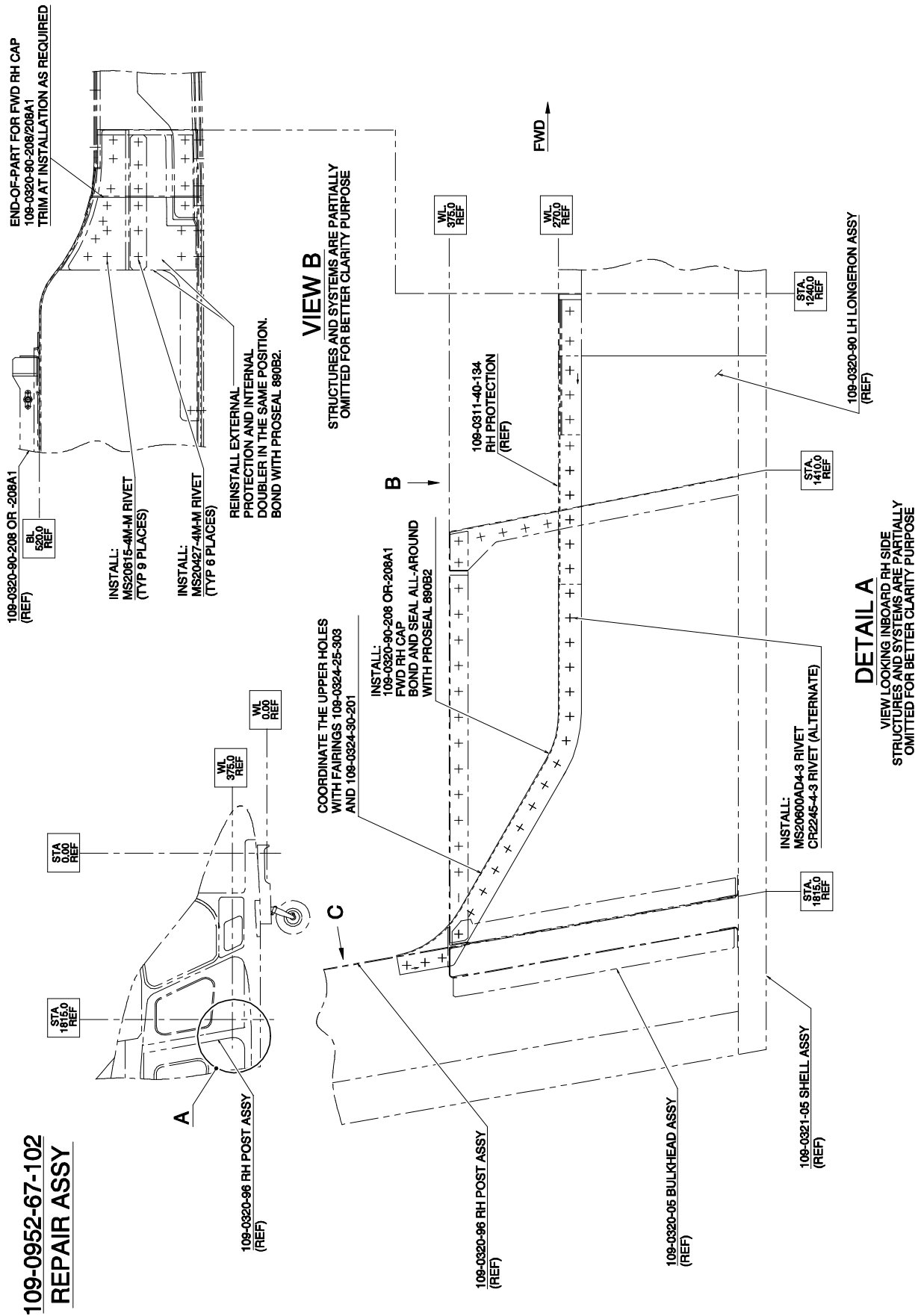
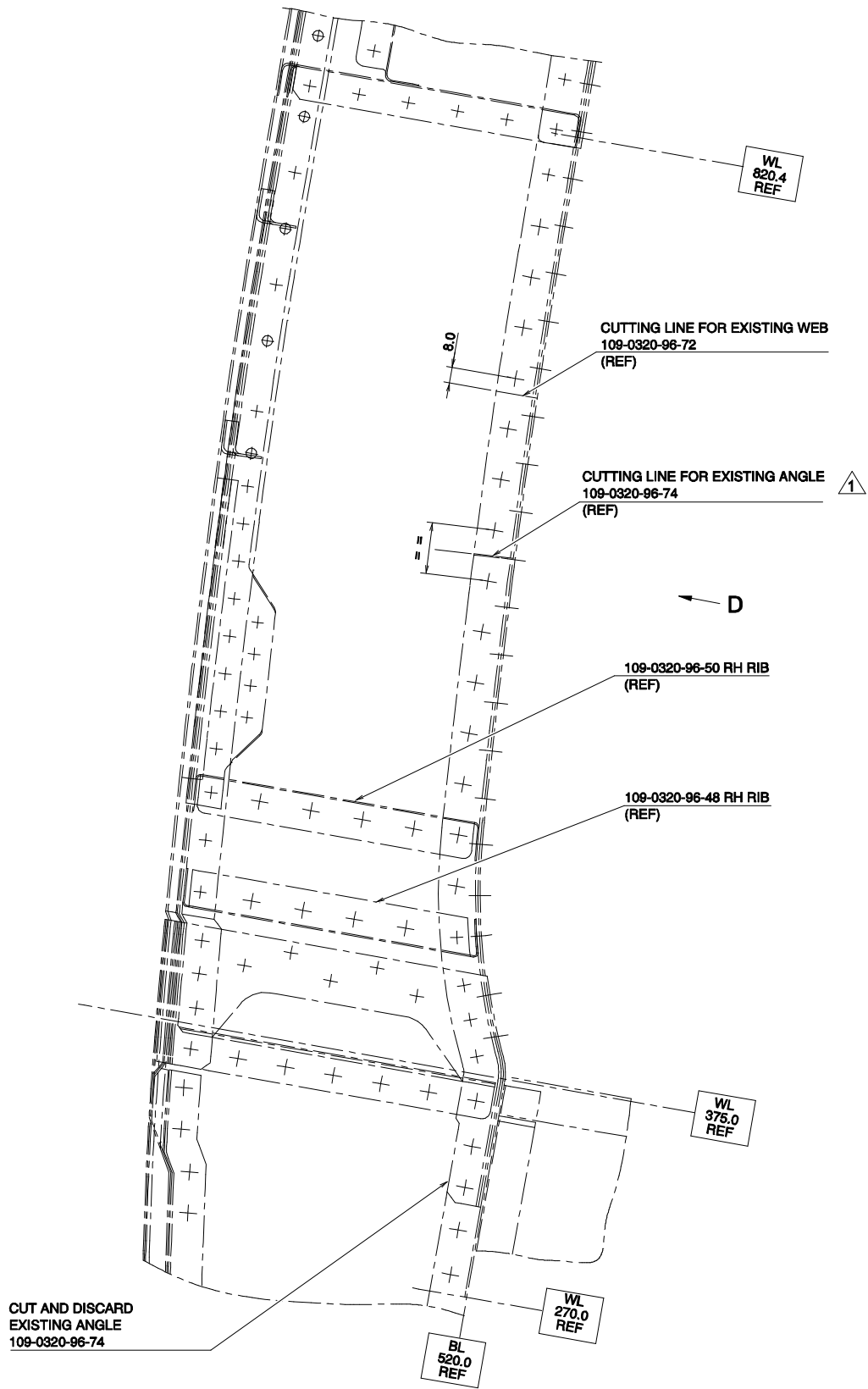

Figure 28

S.B. N°109EP-173 ALERT
DATE: November 10, 2020
REVISION: A - July 21, 2022



VIEW C
STRUCTURES AND SYSTEMS ARE PARTIALLY
OMITTED FOR BETTER CLARITY PURPOSE

Figure 29

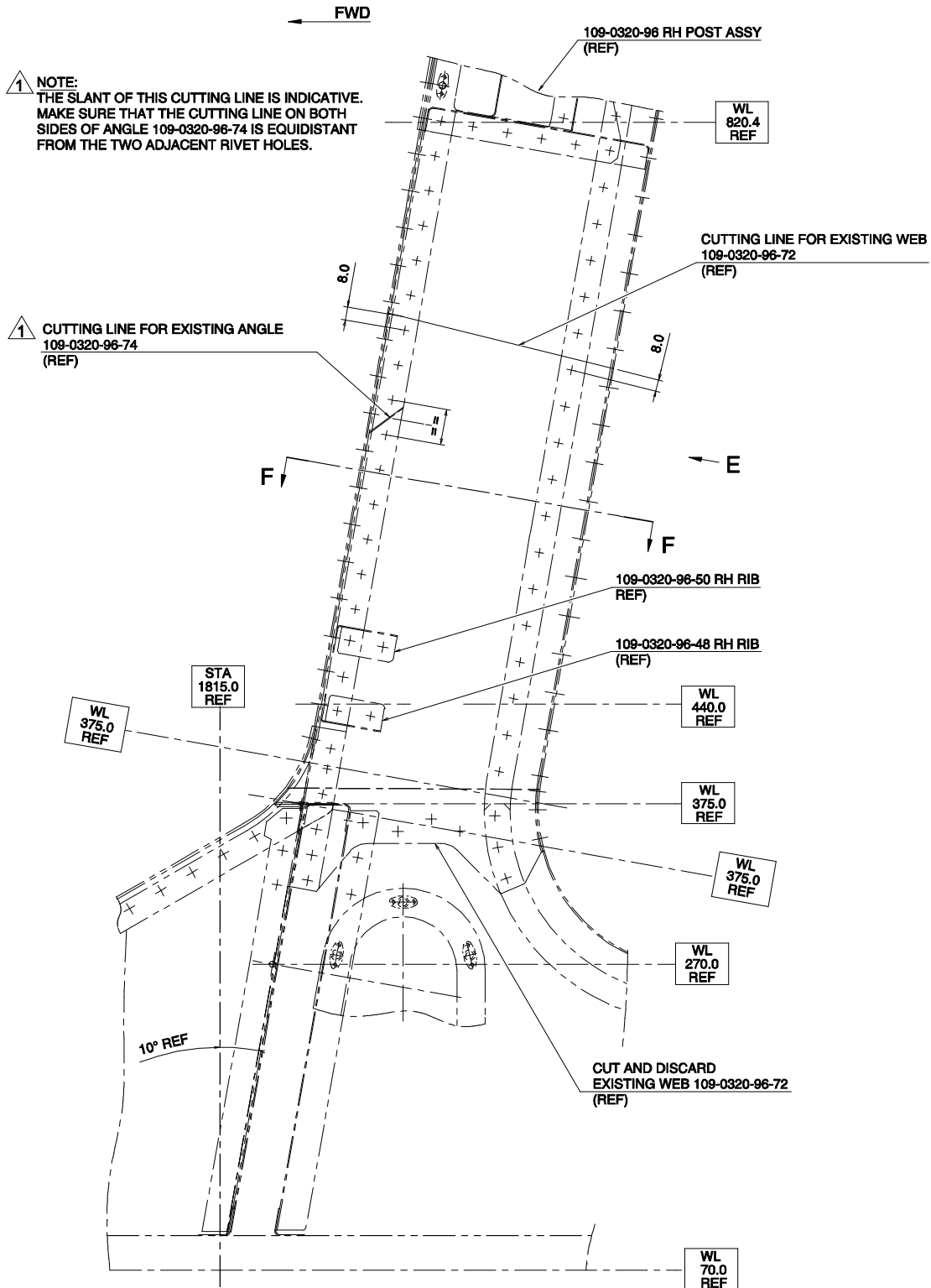

VIEW D
VIEW LOOKING OUTBOARD RH SIDE
STRUCTURES AND SYSTEMS ARE PARTIALLY
OMITTED FOR BETTER CLARITY PURPOSE

Figure 30

S.B. N°109EP-173 ALERT
DATE: November 10, 2020
REVISION: A - July 21, 2022

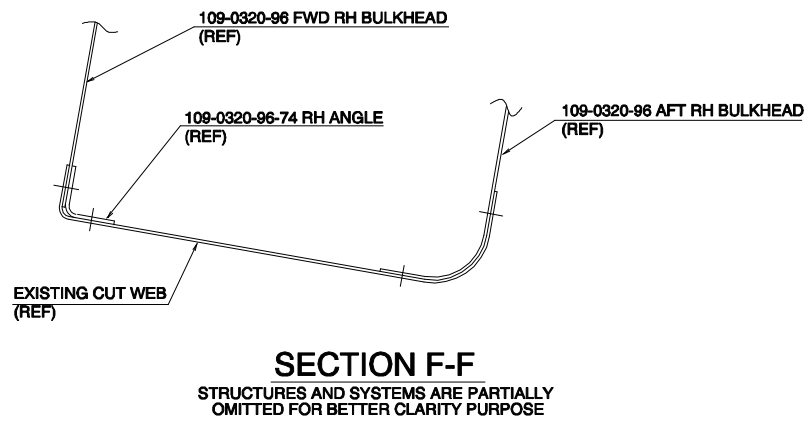
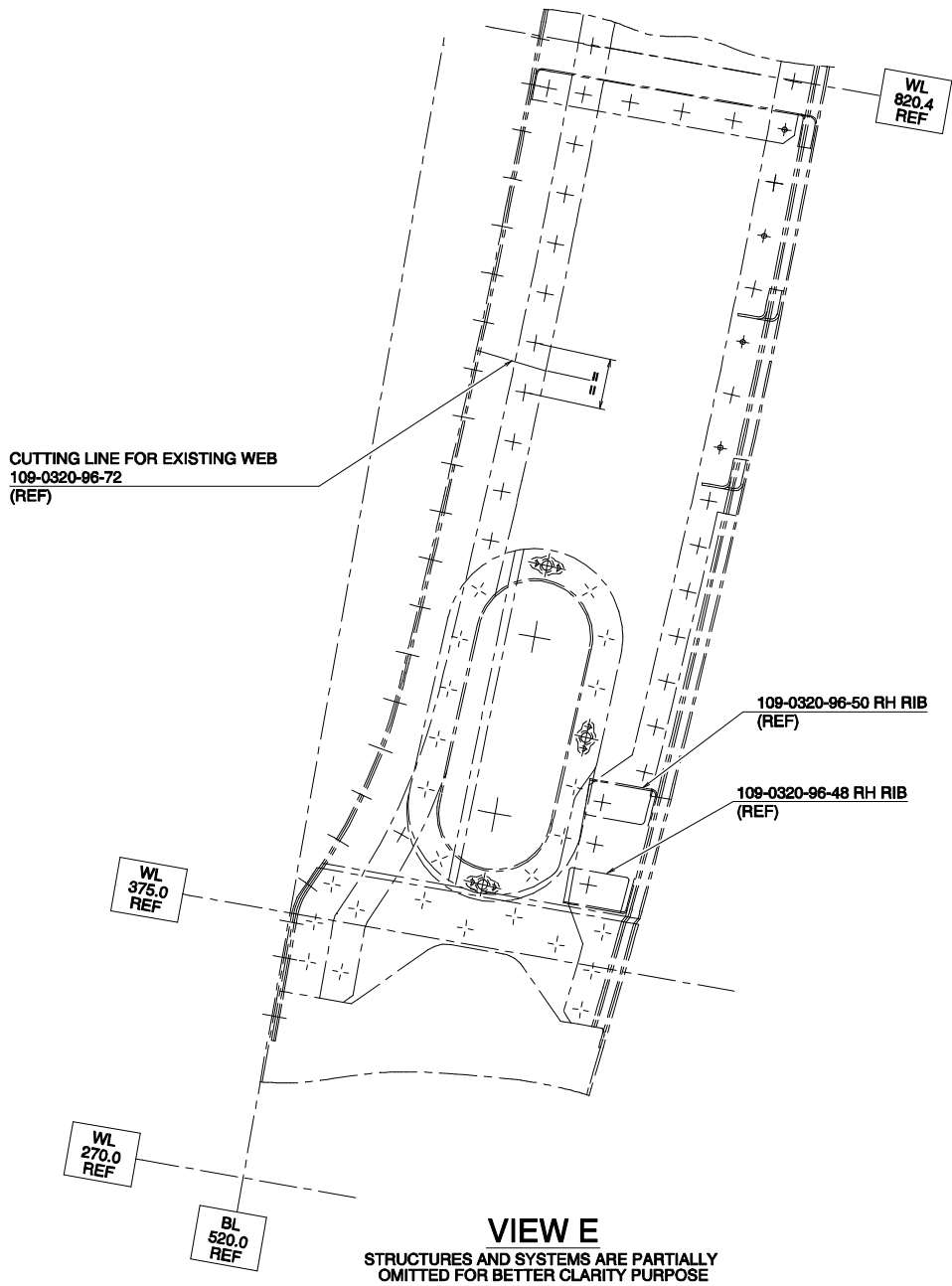
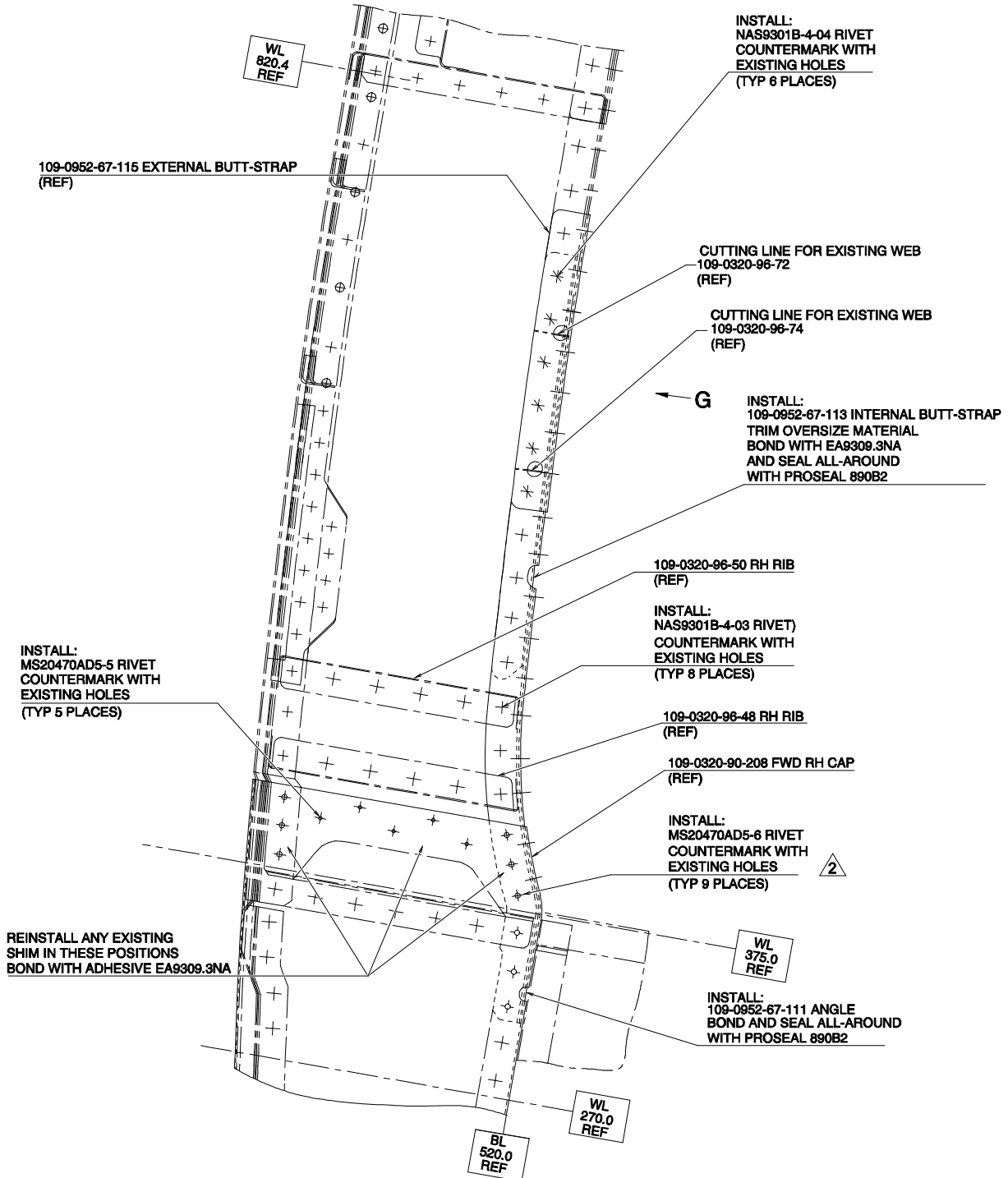

Figure 31

2 NOTE:
IF REQUIRED DUE TO
ADDITIONAL SHIMS IN THE POST,
USE RIVETS MS20426AD5-8 OR
MS20406AD5-9.



VIEW C
STRUCTURES AND SYSTEMS ARE PARTIALLY
OMITTED FOR BETTER CLARITY PURPOSE

Figure 32

S.B. N°109EP-173 ALERT
DATE: November 10, 2020
REVISION: A - July 21, 2022

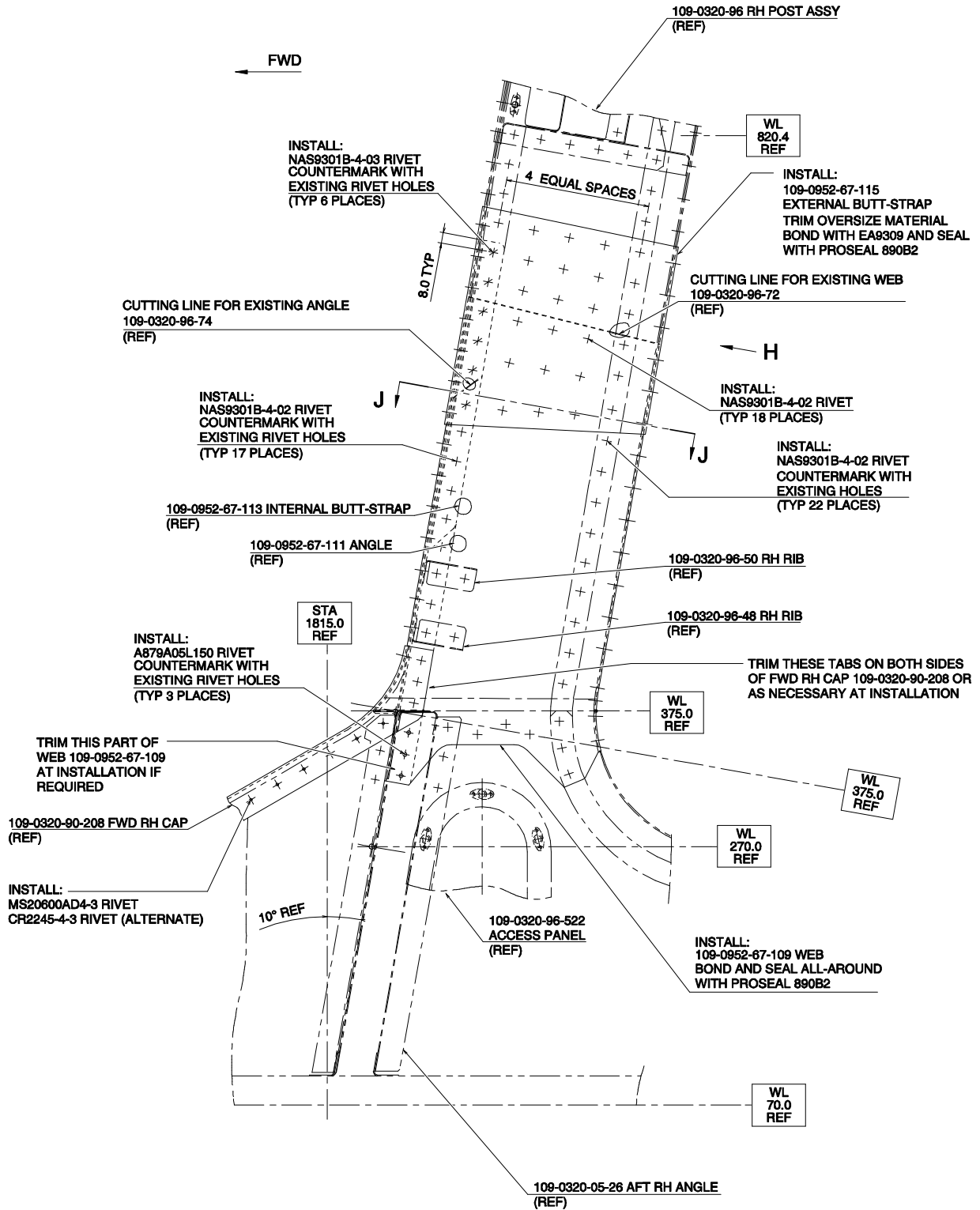

VIEW G
VIEW LOOKING OUTBOARD RH SIDE
STRUCTURES AND SYSTEMS ARE PARTIALLY
OMITTED FOR BETTER CLARITY PURPOSE

Figure 33

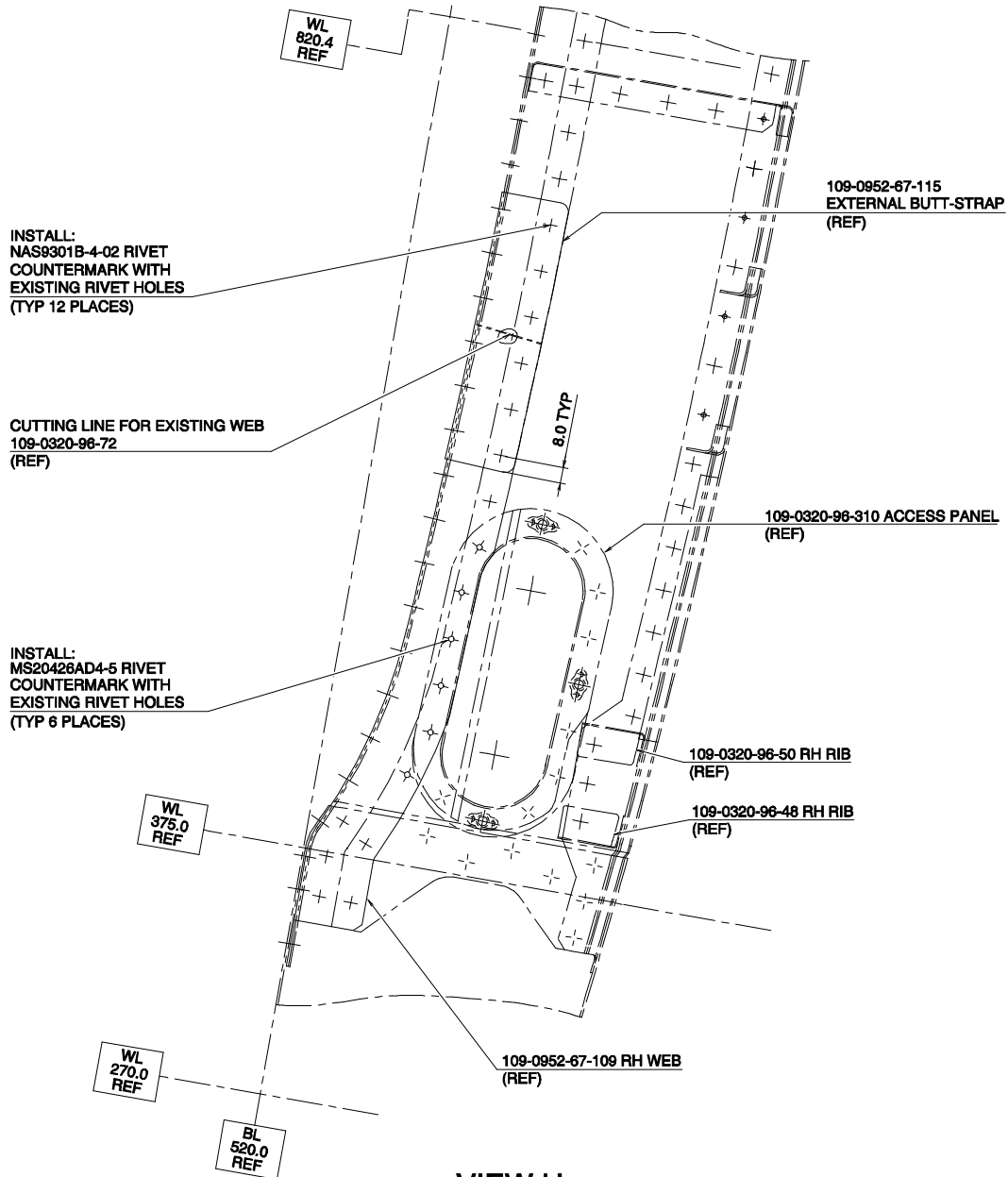

VIEW H

STRUCTURES AND SYSTEMS ARE PARTIALLY OMITTED FOR BETTER CLARITY PURPOSE

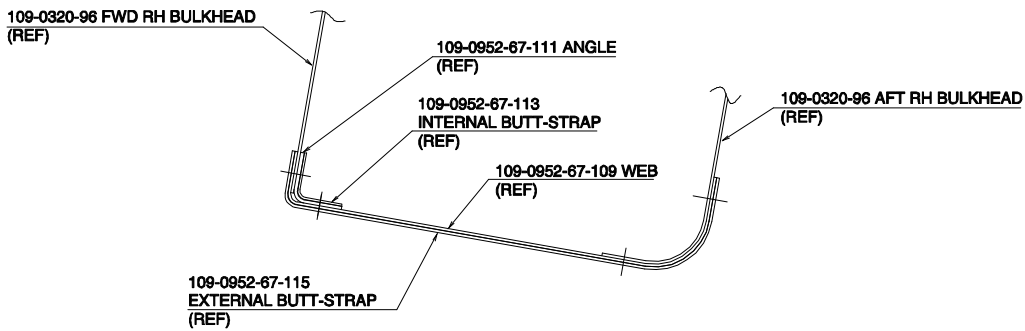

SECTION J-J

STRUCTURES AND SYSTEMS ARE PARTIALLY OMITTED FOR BETTER CLARITY PURPOSE

Figure 34

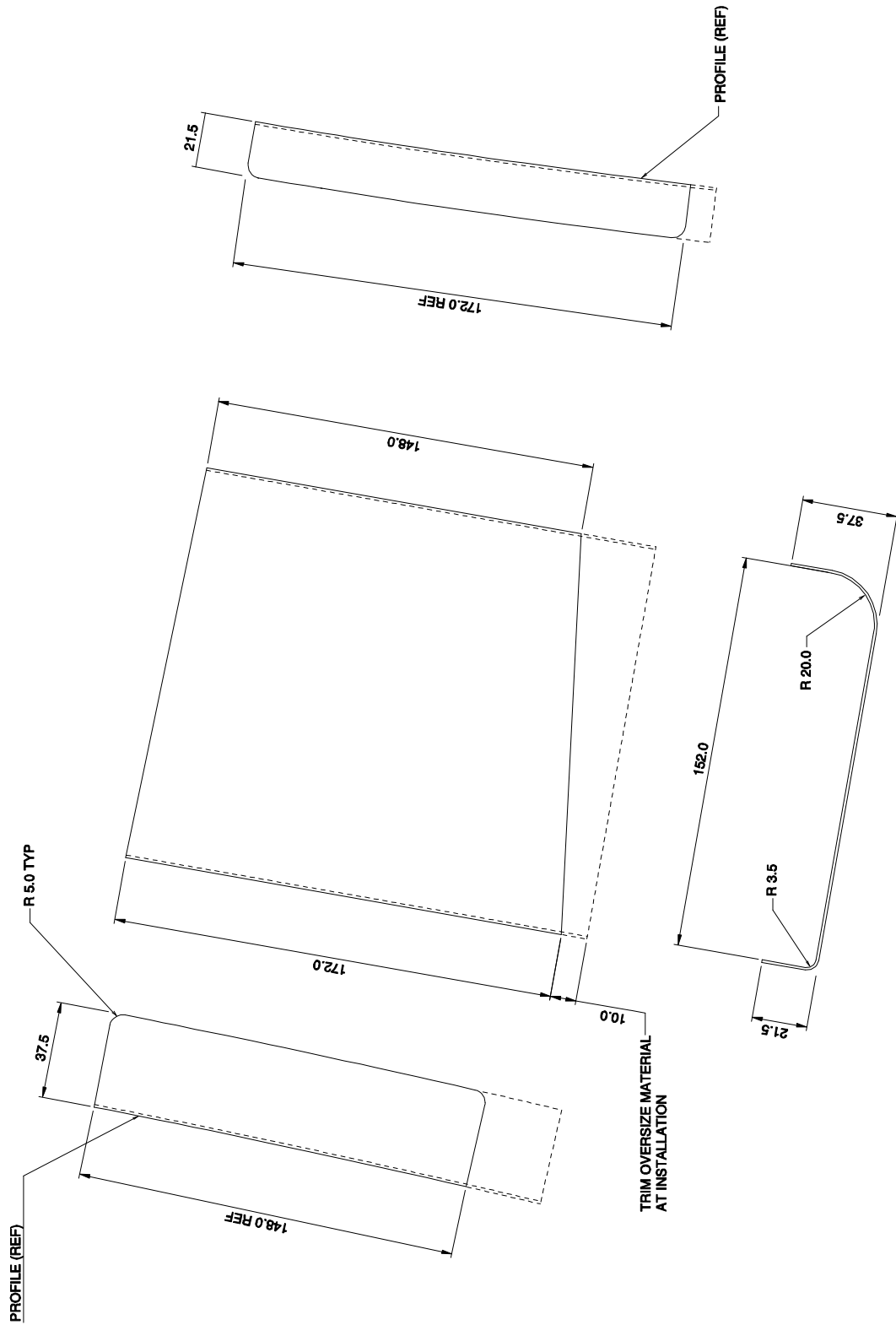

NOTE: THE FINAL DIMENSION SHOWN IS INDICATIVE. VERIFY ALWAYS WITH POSITION OF EXISTING RIVETS BEFORE TO TRIM.

109-0952-67-115 EXTERNAL BUTT-STRAP
(ADAPT TO PROFILE OF POST AT INSTALLATION IF NECESSARY)

Figure 35

TRIM OVERSIZE MATERIAL
AT INSTALLATION

NOTE: THE FINAL DIMENSION SHOWN IS
INDICATIVE. VERIFY ALWAYS WITH
POSITION OF EXISTING RIVETS BEFORE
TO TRIM.

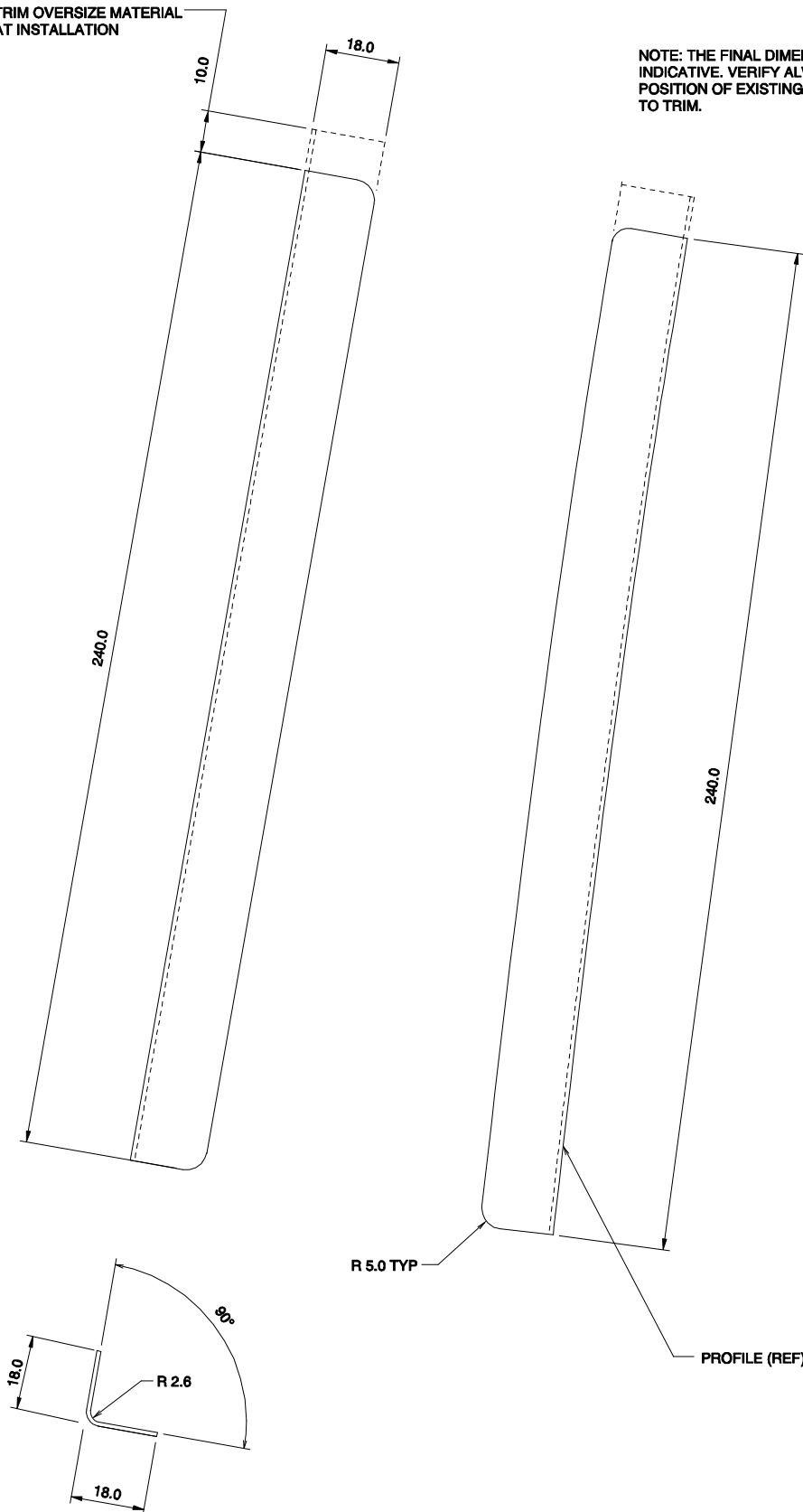

109-0952-67-113 INTERNAL BUTT-STRAP
(ADAPT TO PROFILE OF POST AT INSTALLATION IF NECESSARY)

Figure 36

S.B. N°109EP-173 ALERT
DATE: November 10, 2020
REVISION: A - July 21, 2022

