SERVICE BULLETIN

N° 189-340

DATE: March 7, 2023

REV. : /

TITLE

ATA 52 - PASSENGER FOLDABLE FOOTSTEP STOP RETROMOD

REVISION LOG

First Issue

An appropriate entry should be made in the aircraft log book upon accomplishment.
If ownership of aircraft has changed, please, forward to new owner.

1. PLANNING INFORMATION

A. EFFECTIVITY

Part I

AW189 helicopter S/N 49023

Part II

All AW189 helicopters from S/N 49007 to S/N 49094 (S/N's 49023, 49024, 49036, 49040 and 49041 excluded), from S/N 89001 to S/N 89014 (S/N's 89005 and 89006 excluded) and from S/N 92001 to S/N 92010 equipped with "kit pax electrical foldable footsteps" P/N 8G5260F00211.

B. COMPLIANCE

At Customer's option.

C. CONCURRENT REQUIREMENTS

N.A.

D. REASON

This Service Bulletin is issued in order to provide the necessary instruction on how to perform the "pax foldable footstep stop retromod" P/N 8G5260P01211 and to install an additional lock wire on the foldable footstep micro-switches.

E. DESCRIPTION

The current design of the electrical foldable footstep experienced few malfunctions reported by the Customers, among which vibrations movement, that can be detected when the footstep is in the closed position, and problems during the footstep extension and retraction.

To prevent further occurrences, LHD developed a new improved design for the electrical foldable footstep.

This SB gives instructions on how to install a new stop for the step in order to correctly keep it in full closed positions. As further improvement, a lock wire is introduced to the extended and retracted micro switches nuts.

F. APPROVAL

The technical content of this Service Bulletin is approved under the authority of DOA nr. EASA.21.J.005. For helicopters registered under other Aviation Authorities, before applying the Service Bulletin, applicable Aviation Authority approval must be checked within Leonardo Helicopters customer portal.

S.B. N°189-340
DATE: March 7, 2023
REVISION: /

EASA states mandatory compliance with inspections, modifications or technical directives and related time of compliance by means of relevant Airworthiness Directives. If an aircraft listed in the effectivity embodies a modification or repair not LHD certified and affecting the content of this Service Bulletin, it is responsibility of the Owner/Operator to obtain a formal approval by Aviation Authority having jurisdiction on the aircraft, for any adaptation necessary before incorporation of the present Service Bulletin.

G. MANPOWER

To comply with this Service Bulletin the following MMH are deemed necessary:

Part I: approximately eighty (80) MMH;

Part II: approximately four (4) MMH;

MMH are based on hands-on time and can change with personnel and facilities available.

H. WEIGHT AND BALANCE

Part I

WEIGHT (Kg)	ARM (mm)	MOMENT (Kgmm)
		0.396
LONGITUDINAL BALANCE	4301.5	1703.4
LATERAL BALANCE	0.0	0.0

Part II

N.A.

I. REFERENCES

1) PUBLICATIONS

Following Data Modules refer to AMP:

<u>DATA MODULE</u>	<u>DESCRIPTION</u>	<u>PART</u>
DM01 89-A-00-20-00-00A-120A-A	Helicopter on ground for a safe maintenance.	I, II
DM02 89-A-52-64-01-00A-520A-A	Left/right footstep forward fairing - Remove procedure.	I
DM03 89-A-52-64-01-00A-720A-A	Left/right footstep forward fairing - Install procedure.	I
DM04 89-A-52-64-02-00A-520A-A	Left/right footstep aft fairing - Remove procedure.	I
DM05 89-A-52-64-02-00A-720A-A	Left/right footstep aft fairing - Install procedure.	I

<u>DATA MODULE</u>	<u>DESCRIPTION</u>	<u>PART</u>
DM06 89-A-52-64-04-01A-520A-A	Left/right footstep actuator access panel - Remove procedure.	I,II
DM07 89-A-52-64-04-01A-720A-A	Left/right footstep actuator access panel - Install procedure.	I,II
DM08 89-A-52-64-05-00A-520A-A	Left/right foldable footstep - Remove procedure.	I,II
DM09 89-A-52-64-05-00A-530A-B	Left/right foldable footstep - Disassemble procedure.	I
DM10 89-A-52-64-05-00A-710A-B	Left/right foldable footstep - Assemble procedure.	I
DM11 89-A-52-64-05-00A-720A-A	Left/right foldable footstep - Install procedure.	I,II
DM12 89-A-52-64-07-00A-520A-A	Left/right foldable footstep extended switch - Remove procedure	I,II
DM13 89-A-52-64-07-00A-720A-A	Left/right foldable footstep extended switch - Install procedure	I,II
DM14 89-A-52-64-08-00A-520A-A	Left/right foldable footstep retract switch - Remove procedure	I,II
DM15 89-A-52-64-08-00A-720A-A	Left/right foldable footstep retract switch - Install procedure	I,II
DM16 89-A-20-00-00-00A-712A-A	Fasteners, caps, electrical connectors and turnbuckles - Lock procedure	I,II

2) ACRONYMS & ABBREVIATIONS

AMDI	Aircraft Material Data Information
AMP	Aircraft Maintenance Publication
AR	As Required
CSPP	Common Standard Practices Publication
DM	Data Module
DOA	Design Organization Approval
EASA	European Aviation Safety Agency
FWD	Forward
IPD	Illustrated Part Data
ITEP	Illustrated tool and equipment publication
LH	Left Hand
LHD	Leonardo Helicopters Division
MMH	Maintenance Man Hours
N.A.	Not Applicable
P/N	Part Number
RH	Right Hand

SB Service Bulletin

S/N Serial Number

3) ANNEX

N.A.

J. PUBLICATIONS AFFECTED

N.A.

K. SOFTWARE ACCOMPLISHMENT SUMMARY

N.A.

2. MATERIAL INFORMATION

A. REQUIRED MATERIALS

1) PARTS

PART I

#	P/N	ALTERNATIVE P/N	DESCRIPTION	Q.TY	LVL	NOTE	LOG P/N
1	8G5260P01211		PAX FOLDABLE FOOTSTEP STOP RETROMOD	REF	.		
2	8G5260A30551		Stop threaded	4	..		189-340L1
3	8G5260A30651		Stop angle	4	..		189-340L1
4	8G5260A30751		Stop rubber	4	..		189-340L1
5	AW009TB3C03	A875A3C03	Bolt	8	..		189-340L1
6	MS21043-3		Nut	8	..		189-340L1
7	NAS509-4C		Nut	8	..		189-340L1

PART II

N.A.

Refer also to IPD for the spares materials required to comply with the AMP DMs referenced in the accomplishment instructions.

2) CONSUMABLES

The following consumable materials, or equivalent, are necessary to accomplish this Service Bulletin:

#	SPEC./LHD CODE NUMBER	DESCRIPTION	Q.TY	NOTE	PART
8	A115A2516AB	Seal	AR	(2)	I
9	199-05-107 Type I Class 1	Adhesive EC1357 (C455)	AR	(2)	I
10	199-05-107 Type II Class 5	Adhesive (C111)	AR	(2)	I
11	MS20995C32	Lock wire	AR	(2)	I,II

Refer also to AMDI for the consumable materials required to comply with the AMP DM referenced in the accomplishment instructions.

3) LOGISTIC MATRIX

In order to apply this Service Bulletin, the following Logistic P/N can be ordered in accordance with the applicable notes:

LOGISTIC P/N	Q.TY (PER HELO)	NOTE	PART
189-340L1	1	(1)	-

NOTE

- (1) Applicable to all helicopters
- (2) Item to be procured as local supply.

B. SPECIAL TOOLS

Refer to ITEP for the special tools required to comply with the AMP DM referenced in the accomplishment instructions.

C. INDUSTRY SUPPORT INFORMATION

Product enhancement.

3. ACCOMPLISHMENT INSTRUCTIONS

GENERAL NOTES

- a) Place an identification tag on all components that are re-usable, including the attaching hardware that has been removed to gain access to the modification area and adequately protect them until their later re-use.
- b) Exercise extreme care during drilling operations to prevent instruments, cables and hoses damage.
- c) After drilling, remove all swarf and sharp edges. Apply on bare metal a light film of primer unless the hole is used for ground connection.
- d) Let adhesive cure at room temperature for at least 24 hours unless otherwise specified.
- e) Exposed thread surface and nut must be protected using a layer of tectyl according to MIL-C-16173 grade I.
- f) All lengths are in mm.

PART I

1. In accordance with AMP DM 89-A-00-20-00-00A-120A-A, prepare the helicopter on ground for a safe maintenance. Disconnect the battery, all electrical power sources and/or the external power supply.
2. With reference to Figures 1 thru 7, perform the "pax foldable footstep retromod" P/N 8G5260P01211 as described in the following procedure:
 - 2.1 In accordance with applicable steps of AMP DM 89-A-52-64-01-00A-520A-A and with reference to Figure 1, remove the LH footstep FWD fairing and the related hardware. Retain for later re-use.
 - 2.2 In accordance with applicable steps of AMP DM 89-A-52-64-02-00A-520A-A and with reference to Figure 1, remove the LH footstep aft fairing and the related hardware. Retain for later re-use.
 - 2.3 In accordance with applicable steps of AMP DM 89-A-52-64-04-01A-520A-A and with reference to Figure 1, remove the LH footstep actuator access panel and the related hardware. Retain for later re-use.

- 2.4 In accordance with applicable steps of AMP DM 89-A-52-64-05-00A-520A-A and with reference to Figure 1, remove the LH foldable footstep and the related hardware. Retain for later re-use.
- 2.5 With reference to AMP DM 89-A-52-64-05-00A-520A-A and with reference to Figure 6 View P and Figure 7 View Q, make sure that the bolts of the n°4 brackets that attach the foldable step to the helicopter structure are correctly locked with the applicable lockwire. In accordance with AMP DM 89-A-20-00-00-00A-712A-A, if necessary install lock wire P/N MS20995C32 to the n°20 bolt heads.
- 2.6 With reference to AMP DM 89-A-52-64-07-00A-520A-A and with reference to Figure 6 View P and Figure 7 View R, remove the foldable footstep extended switch with the related hardware. Retain for later re-use.
- 2.7 With reference to AMP DM 89-A-52-64-08-00A-520A-A and with reference to Figure 6 View P and Figure 7 View S, remove the foldable footstep retract switch with the related hardware. Retain for later re-use.
- 2.8 With reference to AMP DM 89-A-52-64-07-00A-720A-A and with reference to Figure 6 View P and Figure 7 View R, re-install the foldable footstep extended switch by means of the previously removed hardware (Ref. step 2.6). In accordance with AMP DM 89-A-20-00-00-00A-712A-A, secure the nuts by means of lockwire P/N MS20995C32.
- 2.9 With reference to AMP DM 89-A-52-64-08-00A-720A-A and with reference to Figure 6 View P and Figure 7 View S, re-install the foldable footstep retract switch by means of the previously removed hardware (Ref. step 2.7). In accordance with AMP DM 89-A-20-00-00-00A-712A-A, secure the nuts by means of lockwire P/N MS20995C32.
- 2.10 In accordance with applicable steps of AMP DM 89-A-52-64-05-00A-530A-B, remove from the LH foldable footstep the following components:
 - Rail P/N 8G5260A21151;
 - Rail P/N 8G5260A21651;
 - Closure fairing assy P/N 8G5260A22631;
- 2.11 With reference to Figure 3 View C, drill n°2 holes \varnothing 5.326÷5.446 and countersink 130°x1.19÷1.24 as indicated on the rail P/N 8G5260A21151.
- 2.12 With reference to Figure 3 View D, drill n°2 holes \varnothing 5.326÷5.446 and countersink 130°x1.19÷1.24 as indicated on the rail P/N 8G5260A21651.
- 2.13 With reference to Figure 4 View E, install the stop angle P/N 8G5260A30651 by means of n°2 bolts P/N AW009TB3C03 and n°2 nuts P/N MS21043-3 on the rail P/N 8G5260A21151.

NOTE

To avoid any possible vibration in fully closed step position, the stop threaded can be adjusted up to a maximum extension of 19.0mm.

- 2.14 With reference to Figure 4 View E, install the stop threaded P/N 8G5260A30551 by means of n°2 nuts P/N NAS509-4C on the stop angle P/N 8G5260A30651. In accordance with AMP DM 89-A-20-00-00-00A-712A-A, secure by means of lock wire P/N MS20995C32.
- 2.15 With reference to Figure 4 View F, install the stop angle P/N 8G5260A30651 by means of n°2 bolts P/N AW009TB3C03 and n°2 nuts P/N MS21043-3 on the rail P/N 8G5260A21651.

NOTE

To avoid any possible vibration in fully closed step position, the stop threaded can be adjusted up to a maximum extension of 19.0mm.

- 2.16 With reference to Figure 4 View F, install the stop threaded P/N 8G5260A30551 by means of n°2 nuts P/N NAS509-4C on the stop angle P/N 8G5260A30651. In accordance with AMP DM 89-A-20-00-00-00A-712A-A, secure by means of lock wire P/N MS20995C32.
- 2.17 With reference to Figure 5, install n°2 strips of seal P/N A115A2516AB164 by means of adhesive (C111) on the closure fairing assy.

NOTE

Make sure the rubber stop is parallel to outer face of the closure fairing assy.

- 2.18 With reference to Figure 5 View G and View H, install n°2 stops rubber P/N 8G5260A30751 by means of adhesive EC1357 (C455) on the closure fairing assy.
- 2.19 In accordance with applicable steps of AMP DM 89-A-52-64-05-00A-710A-B, assemble the LH foldable footstep.
- 2.20 In accordance with applicable steps of AMP DM 89-A-52-64-05-00A-720A-A and with reference to Figure 1, re-install the LH foldable footstep by means of the previously removed hardware (Ref. step 2.4).
- 2.21 In accordance with applicable steps of AMP DM 89-A-52-64-04-01A-720A-A and with reference to Figure 1, re-install the LH footstep actuator access panel by means of the previously removed hardware (Ref. step 2.3).

- 2.22 In accordance with applicable steps of AMP DM 89-A-52-64-02-00A-720A-A and with reference to Figure 1, re-install the LH footstep aft fairing by means of the previously removed hardware (Ref. step 2.2).
- 2.23 In accordance with applicable steps of AMP DM 89-A-52-64-01-00A-720A-A and with reference to Figure 1, re-install the LH footstep FWD fairing by means of the previously removed hardware (Ref. step 2.1).
- 2.24 Perform again Step 2.1 thru Step 2.23 to modify the RH footstep.
3. Return the helicopter to flight configuration and record for compliance with Part I of this Service Bulletin on the helicopter logbook.
4. Send the attached compliance form to the following mail box:
engineering.support.lhd@leonardo.com

As an alternative, gain access to My Communications section on Leonardo WebPortal and compile the "Service Bulletin Application Communication".

PART II

1. In accordance with AMP DM 89-A-00-20-00-00A-120A-A, prepare the helicopter on ground for a safe maintenance. Disconnect the battery, all electrical power sources and/or the external power supply.
2. With reference to Figure 1, Figures 6 and 7, perform the following procedure:
 - 2.1 In accordance with applicable steps of AMP DM 89-A-52-64-04-01A-520A-A and with reference to Figure 1, remove the LH footstep actuator access panel and the related hardware. Retain for later re-use.
 - 2.2 With reference to AMP DM 89-A-52-64-05-00A-520A-A and with reference to Figure 6 View P and Figure 7 View Q, make sure that the bolts of the n°4 brackets that attach the foldable step to the helicopter structure are correctly locked with the applicable lockwire. In accordance with AMP DM 89-A-20-00-00-00A-712A-A, if necessary install lock wire P/N MS20995C32 to the n°20 bolt heads.
 - 2.3 With reference to AMP DM 89-A-52-64-07-00A-520A-A and with reference to Figure 6 View P and Figure 7 View R, remove the foldable footstep extended switch with the related hardware. Retain for later re-use.
 - 2.4 With reference to AMP DM 89-A-52-64-08-00A-520A-A and with reference to Figure 6 View P and Figure 7 View S, remove the foldable footstep retract switch with the related hardware. Retain for later re-use.
 - 2.5 With reference to AMP DM 89-A-52-64-07-00A-720A-A and with reference to Figure 6 View P and Figure 7 View R, re-install the foldable footstep extended switch by means of the previously removed hardware (Ref. step 2.3). In accordance with AMP DM 89-A-20-00-00-00A-712A-A, secure the nuts by means of lockwire P/N MS20995C32.
 - 2.6 With reference to AMP DM 89-A-52-64-08-00A-720A-A and with reference to Figure 6 View P and Figure 7 View S, re-install the foldable footstep retract switch by means of the previously removed hardware (Ref. step 2.4). In accordance with AMP DM 89-A-20-00-00-00A-712A-A, secure the nuts by means of lockwire P/N MS20995C32.
 - 2.7 In accordance with applicable steps of AMP DM 89-A-52-64-04-01A-720A-A and with reference to Figure 1, re-install the LH footstep actuator access panel by means of the previously removed hardware (Ref. step 2.1).
 - 2.8 Perform again Step 2.1 thru Step 2.7 to modify the RH footstep.
3. Return the helicopter to flight configuration and record for compliance with Part II of this Service Bulletin on the helicopter logbook.

4. Send the attached compliance form to the following mail box:

engineering.support.lhd@leonardo.com

As an alternative, gain access to My Communications section on Leonardo WebPortal and compile the “Service Bulletin Application Communication”.

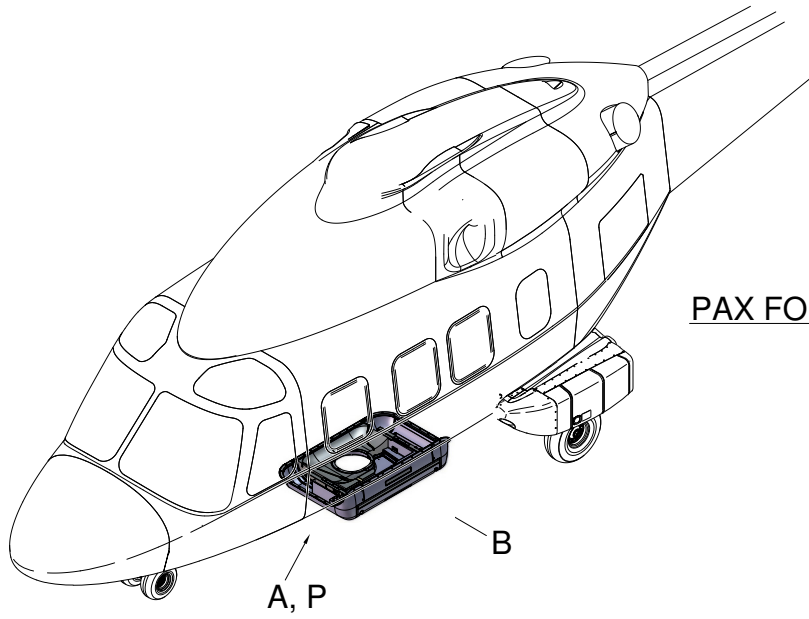

8G5260P01211
PAX FOLDABLE FOOTSTEP STOP
RETROMOD

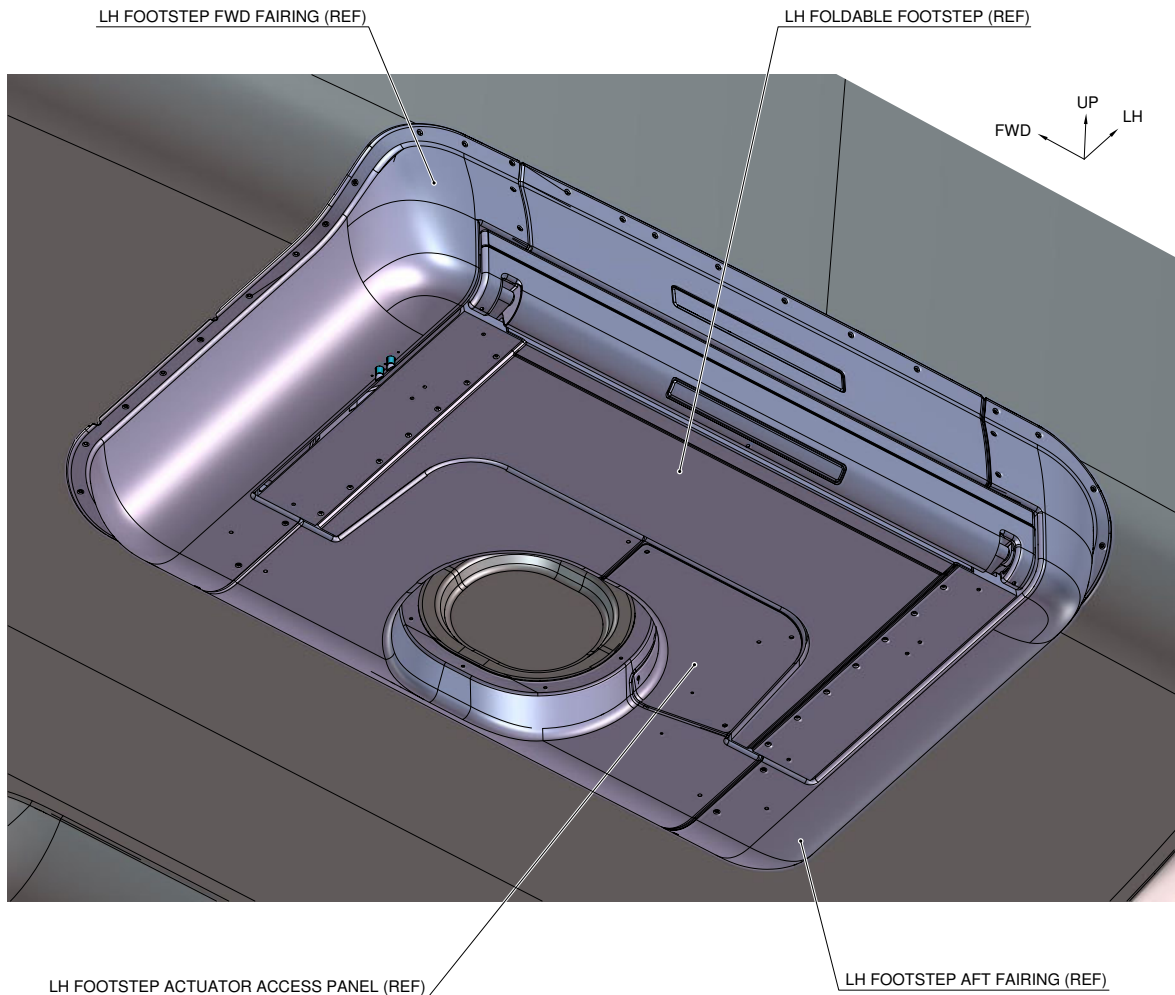

VIEW A

STRUCTURES AND SYSTEMS ARE PARTIALLY
OMITTED FOR BETTER CLARITY PURPOSE

Figure 1

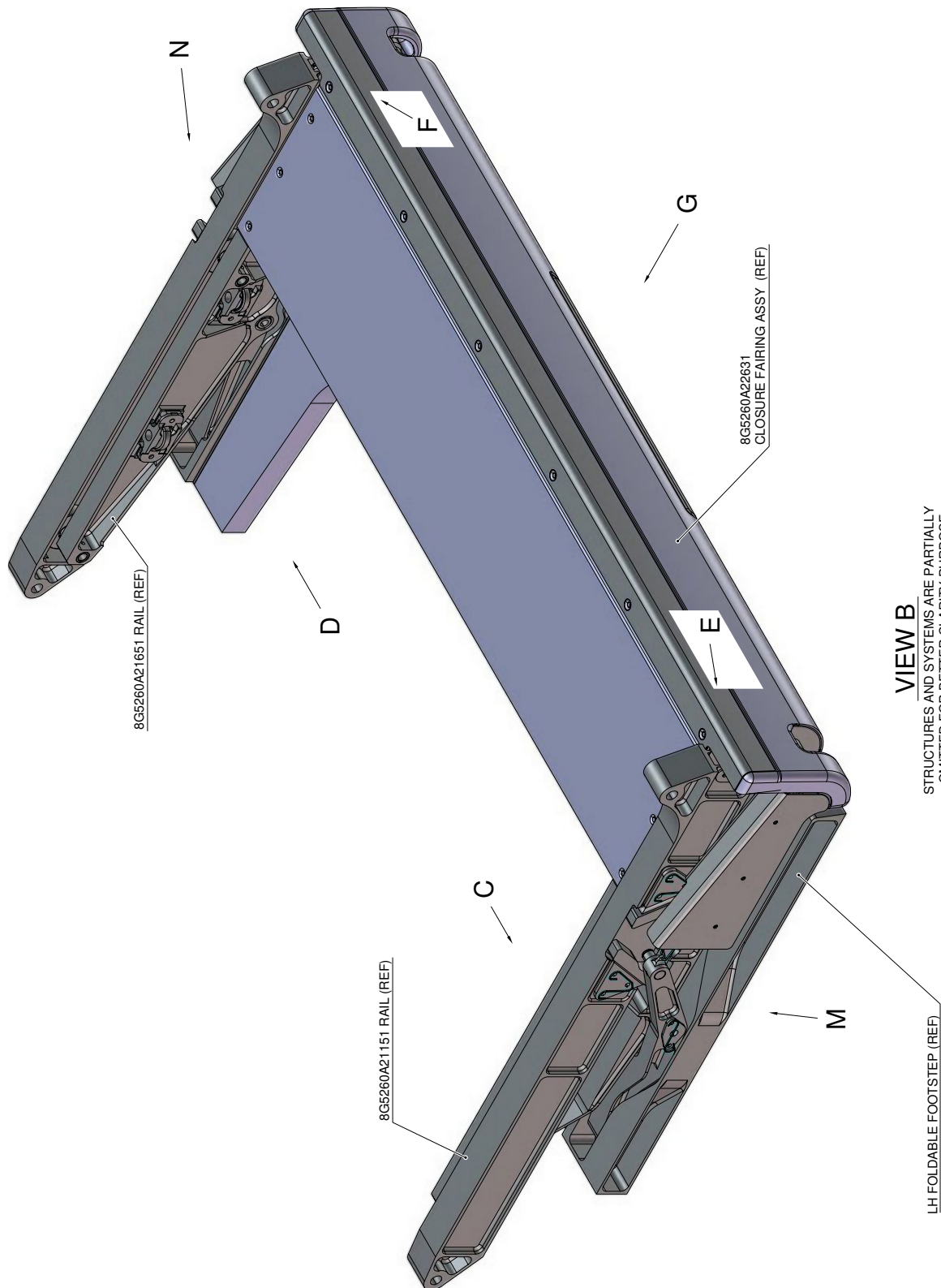
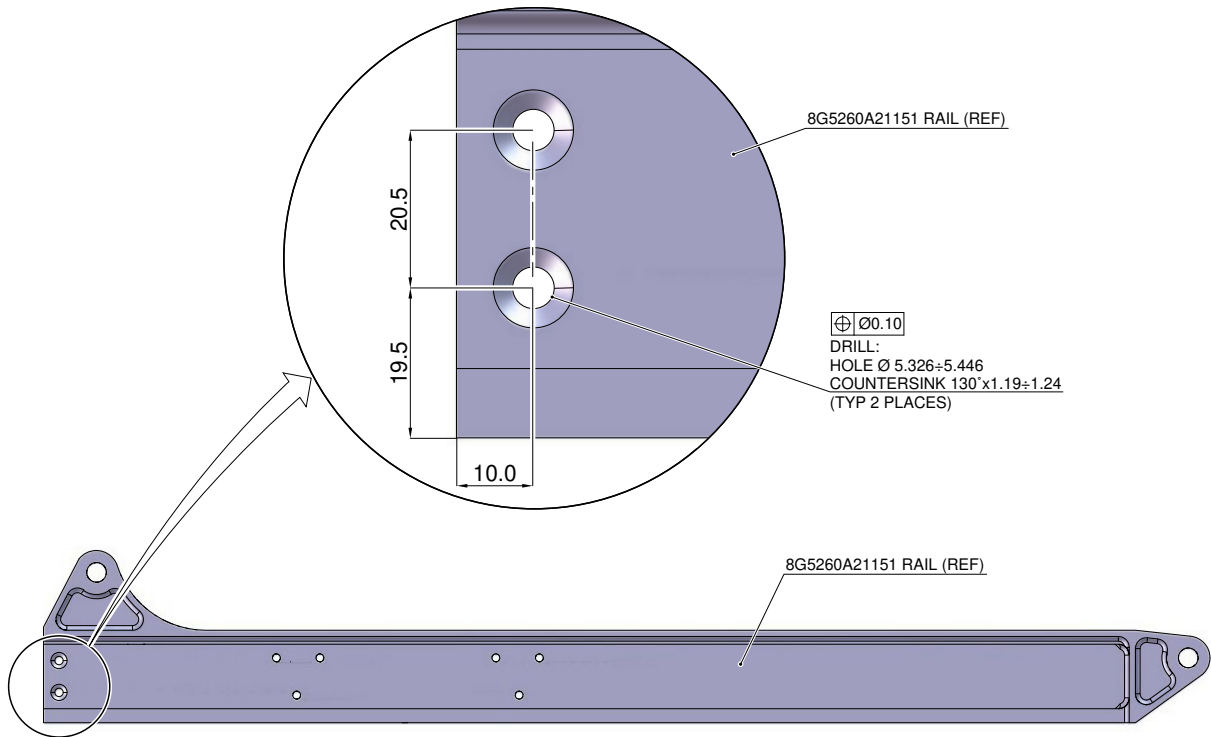
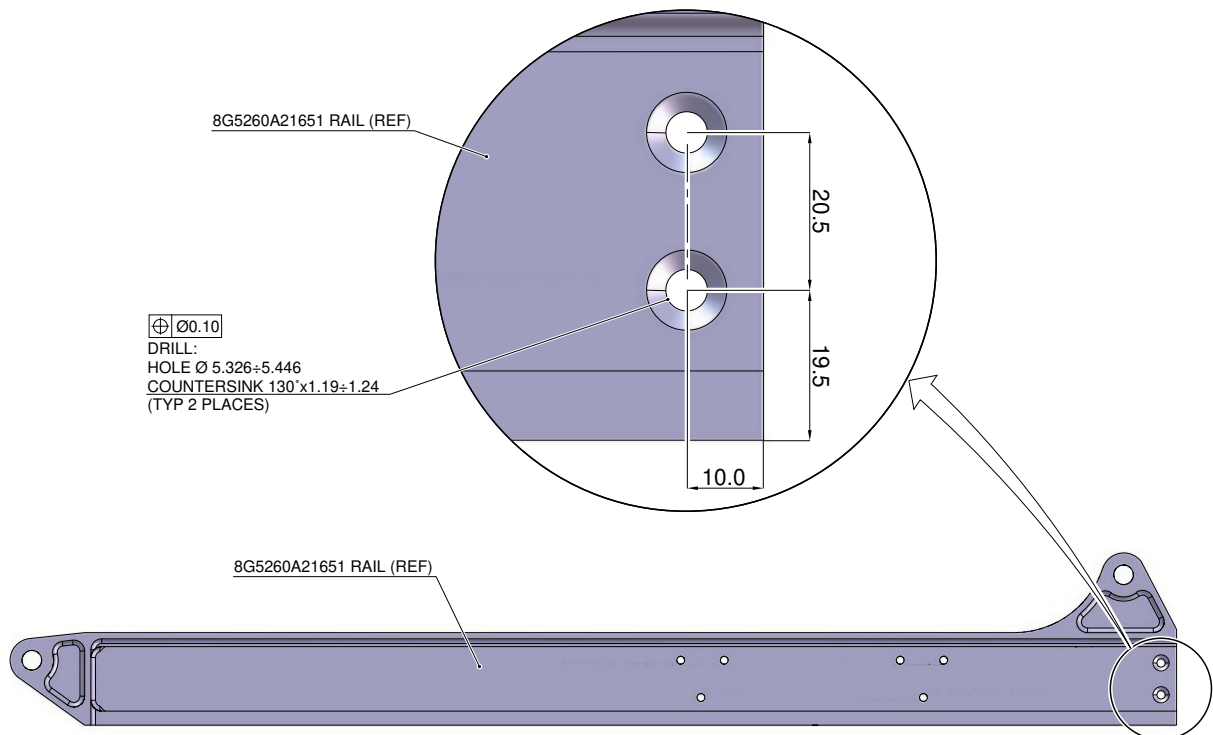

Figure 2



VIEW C

STRUCTURES AND SYSTEMS ARE PARTIALLY
OMITTED FOR BETTER CLARITY PURPOSE



VIEW D

STRUCTURES AND SYSTEMS ARE PARTIALLY
OMITTED FOR BETTER CLARITY PURPOSE

Figure 3

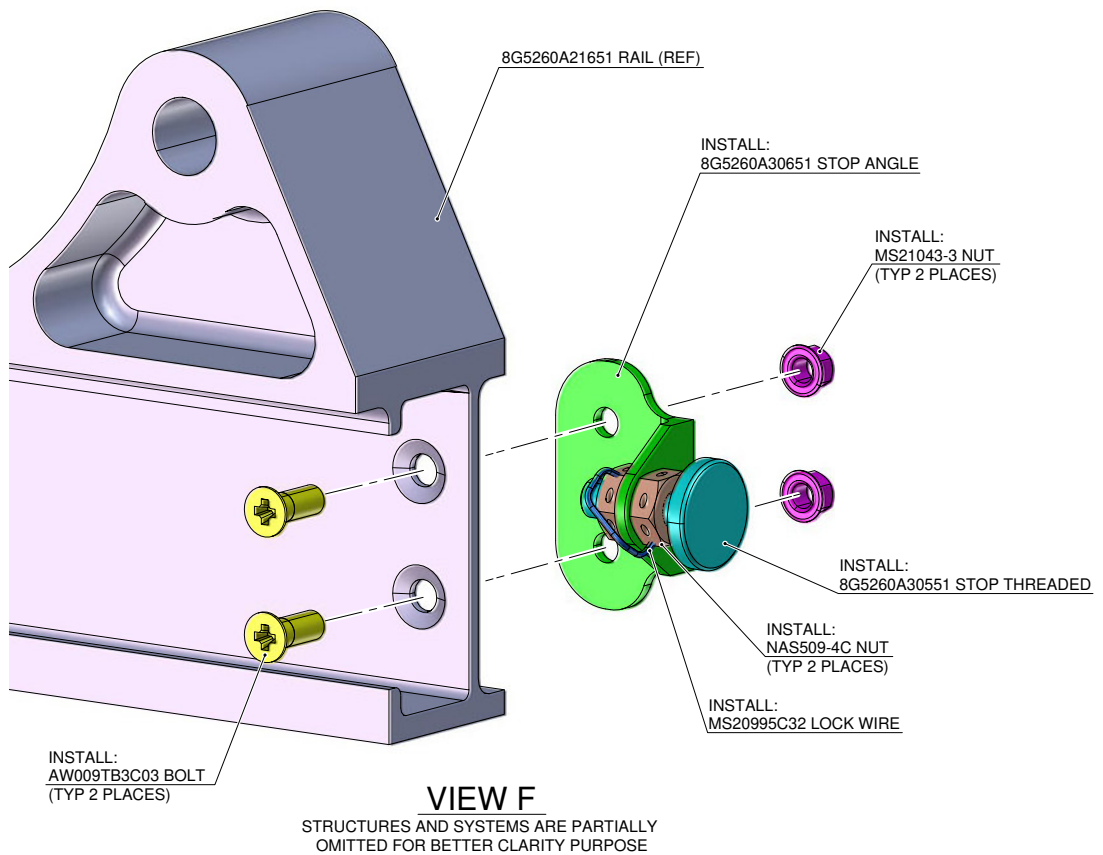
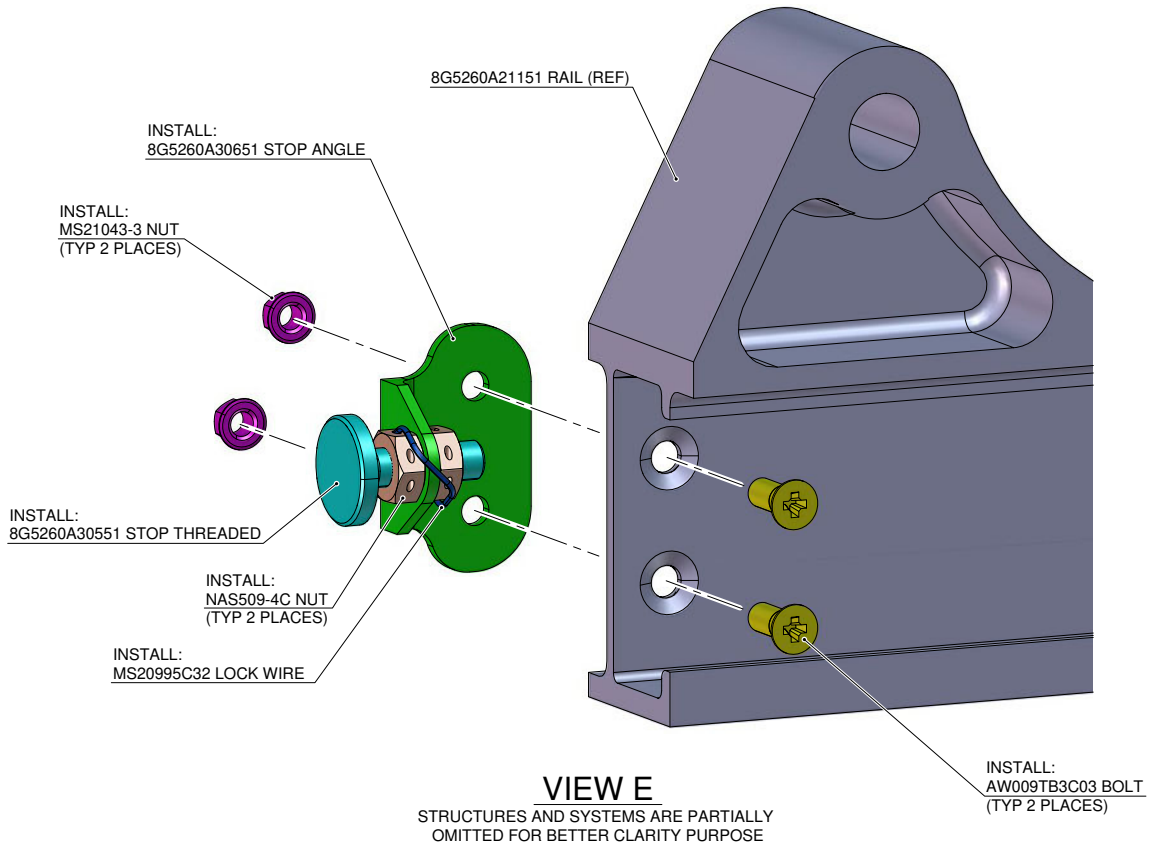
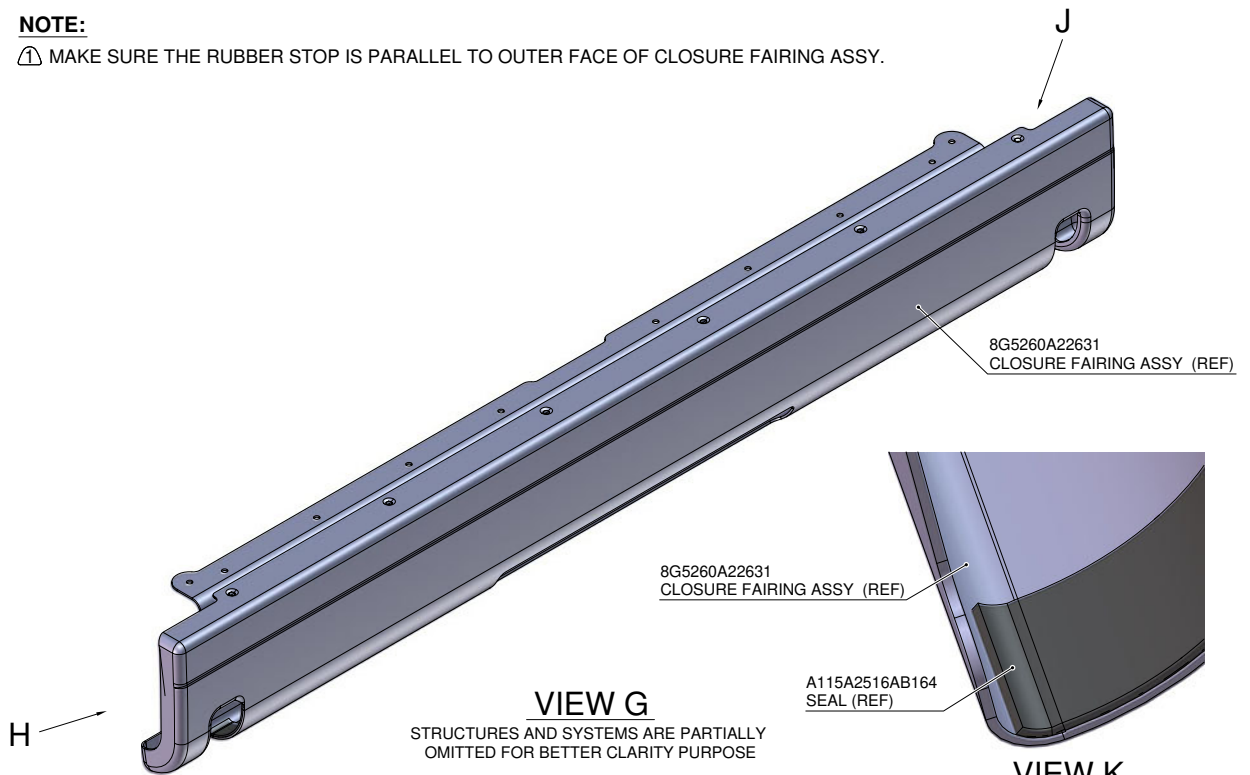

Figure 4

NOTE:

⚠ MAKE SURE THE RUBBER STOP IS PARALLEL TO OUTER FACE OF CLOSURE FAIRING ASSY.



VIEW G

STRUCTURES AND SYSTEMS ARE PARTIALLY OMITTED FOR BETTER CLARITY PURPOSE

VIEW K

TYPICAL 2 PLACES
STRUCTURES AND SYSTEMS ARE PARTIALLY OMITTED FOR BETTER CLARITY PURPOSE

INSTALL:
⚠ 8G5260A30751 STOP RUBBER
APPLY:
EC1357 ADHESIVE
ACCORDING TO P/N 8G5260A30551

INSTALL:
A115A2516AB164 SEAL
APPLY:
199-05-107 TY II CL 5 ADHESIVE

INSTALL:
⚠ 8G5260A30751 STOP RUBBER
APPLY:
EC1357 ADHESIVE
ACCORDING TO P/N 8G5260A30551

INSTALL:
A115A2516AB164 SEAL
APPLY:
199-05-107 TY II CL 5 ADHESIVE

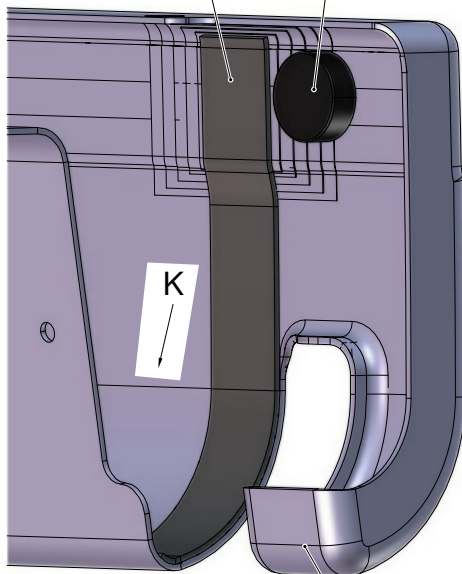

VIEW H

STRUCTURES AND SYSTEMS ARE PARTIALLY OMITTED FOR BETTER CLARITY PURPOSE

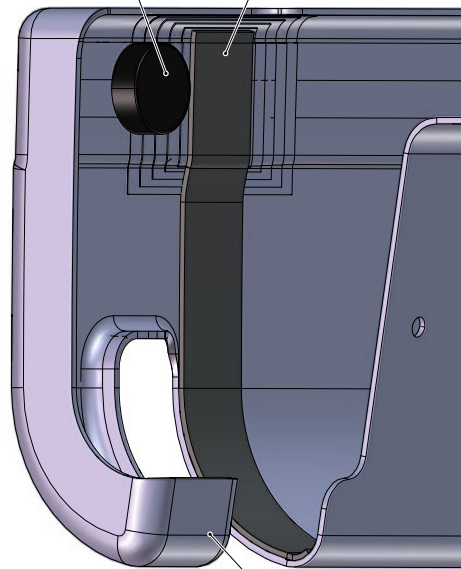

VIEW J

STRUCTURES AND SYSTEMS ARE PARTIALLY OMITTED FOR BETTER CLARITY PURPOSE

Figure 5

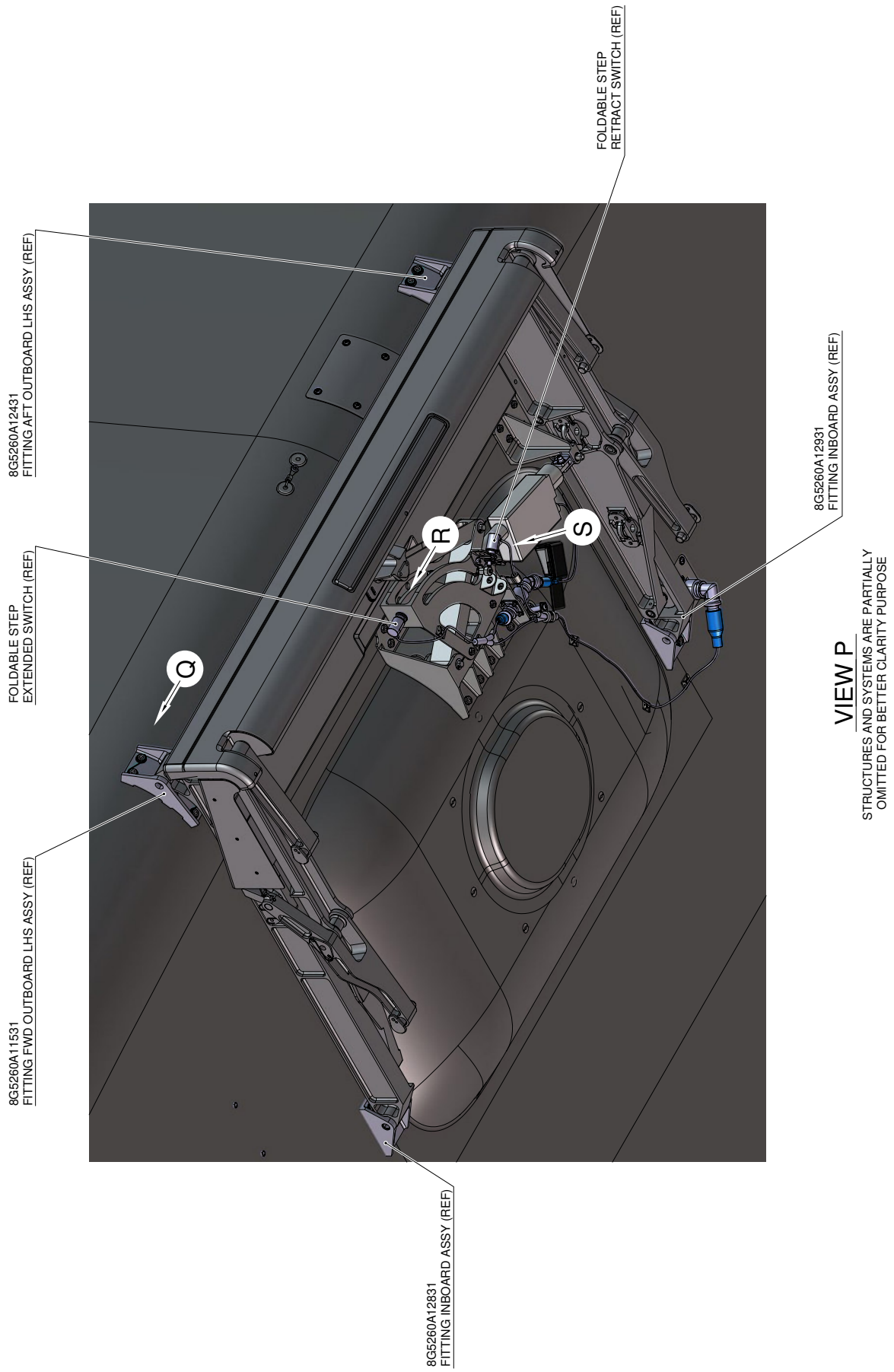
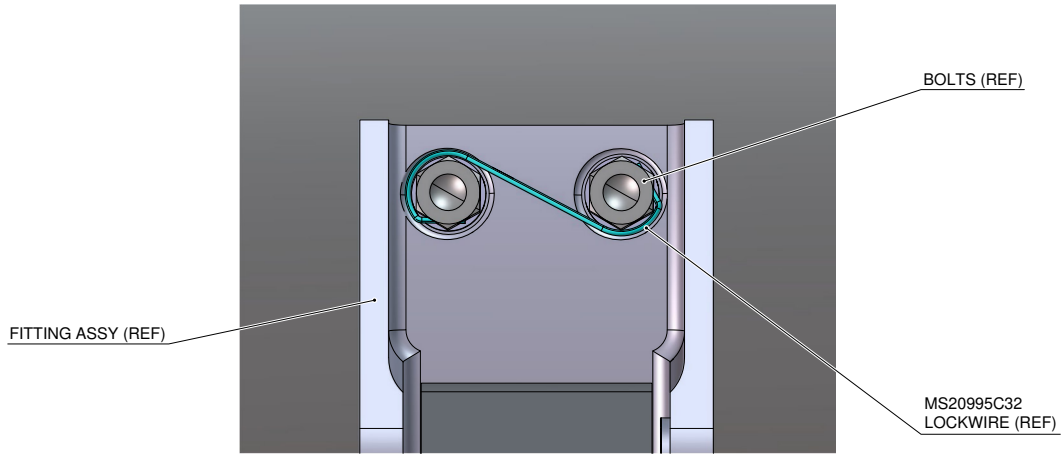

Figure 6



VIEW Q

(TYPICAL)

STRUCTURES AND SYSTEMS ARE PARTIALLY OMITTED FOR BETTER CLARITY PURPOSE

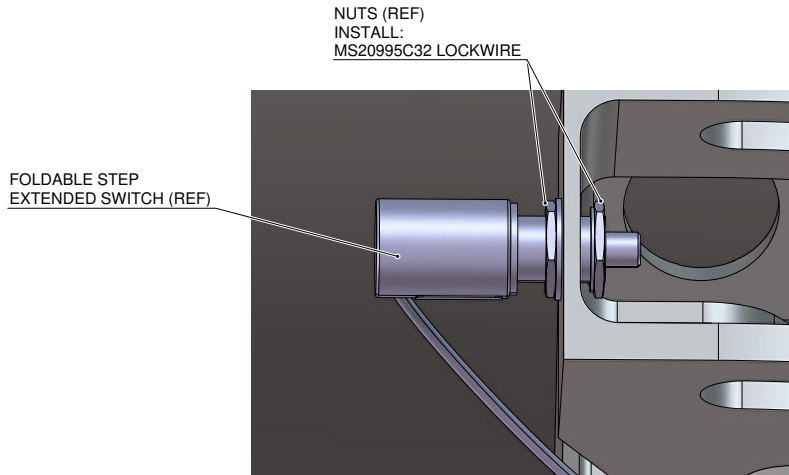

VIEW R

STRUCTURES AND SYSTEMS ARE PARTIALLY OMITTED FOR BETTER CLARITY PURPOSE

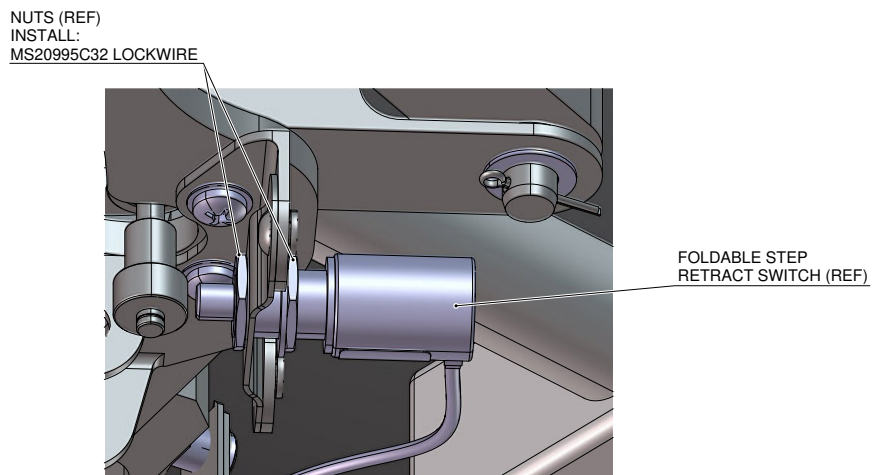

VIEW S

STRUCTURES AND SYSTEMS ARE PARTIALLY OMITTED FOR BETTER CLARITY PURPOSE

Figure 7

