

---

---

**SERVICE BULLETIN**

**N° 189-316**

**DATE:** March 9, 2023

**REV. :** /

---

---

**TITLE**

**ATA 93 - FLIR 380 HDC REMOVABLE PARTS INSTALLATION**

**REVISION LOG**

First Issue

## **1. PLANNING INFORMATION**

### **A. EFFECTIVITY**

AW189 helicopters S/N 49069 and S/N 49070.

### **B. COMPLIANCE**

At Customer's option.

### **C. CONCURRENT REQUIREMENTS**

N.A.

### **D. REASON**

This Service Bulletin is issued in order to provide the necessary instruction on how to complete the installation of Kit FLIR 380 HDc P/N 8G9350F00611.

### **E. DESCRIPTION**

The FLIR Star Safire SS380-HDc is an all-digital, gyro-stabilized EO/IR imaging system configured to operate simultaneously in multiple spectral bands including the visible, near-IR, short wave IR and mid-wave IR bands.

The kit is composed of the following devices:

- Turret-FLIR Unit (TFU)
- Panel-Mounted Control Unit (PCU)
- Quick Disconnect Device (QDD)

The Star SAFIRE 380-HDc is controlled primarily via the Universal Hand Control (UHCU) located in the cabin area to provide FLIR operation to a cabin operator lug, with an additional limited control capability via the Panel-Mount Control Unit (PCU) P/N 4135364-2 located in the cockpit interseat console to provide FLIR operation to both pilot and co-pilot operators. The Universal Hand Control Unit (UHCU) provides the main FLIR user interface.

The TFU unit assembly is installed externally to the helicopter in front of the nose landing gear structure compartment through a suitable structure and fixed to the helicopter by Quick Disconnect Device (QDD) to ease the connection/disconnections operations of the TFU assembly.

This Service Bulletin complete the installation of Kit FLIR 380 HDc, in particular gives information to:

- perform the FLIR HDC pendant in cockpit relocation P/N 8G9350P01111: structural provision of the pendant relocation and installation of the Hand Control Unit (A227) in on the side of the interseat console;
- perform the FLIR Safire SS380 electrical replacement P/N 8G9350A11011: installation of the support AW001CL001-N6;
- perform the FLIR Safire SS380-HDC equipment installation P/N 8G9350A09711: installation of the Panel-Mounted Control Unit (PL18);
- perform the FLIR SS 380 retro mod P/N 8G9350P01211: installation of the bracket assy P/N 8G9350A10231;
- perform the retromod FLIR Safire SS380-HLD P/N 8G9350P00911: replacement of the FLIR Safire SS380-HLD C/A (A2A386) P/N 8G9A22A38601 with the new P/N 8G9A22A38602;
- perform the FLIR SS 380 HDc removable parts P/N 8G9350A12911: installation of the Star Safire SS380-HDc Turret FLIR (A124), the lower assy complete P/N QDD-1-1A and the bonding strap P/N 8G9350A10451;
- perform the FLIR Star Safire 380 structural provision P/N 8G5310A36911: installation of the lower panel RH and LH P/N 8G9350P00451 and P/N 8G9350P00531.

## F. APPROVAL

If an aircraft listed in the effectivity embodies a modification or repair not LHD certified and affecting the content of this Service Bulletin, it is responsibility of the Owner/Operator to obtain a formal approval by Aviation Authority having jurisdiction on the aircraft, for any adaptation necessary before incorporation of the present Service Bulletin.

## G. MANPOWER

To comply with this Service Bulletin twelve (12) MMH are deemed necessary. MMH are based on hands-on time and can change with personnel and facilities available.

## H. WEIGHT AND BALANCE

WEIGHT (Kg)	ARM (mm)	MOMENT (Kgmm)
		34.25
<b>LONGITUDINAL BALANCE</b>	744.70	25506
<b>LATERAL BALANCE</b>	33.98	1163.82

## I. REFERENCES

### 1) PUBLICATIONS

Following Data Modules refer to AMP:

<u>DATA MODULE</u>	<u>DESCRIPTION</u>	<u>PART</u>
DM01 89-A-00-20-00-00A-120A-A	Helicopter on ground for a safe maintenance	-
DM02 89-A-06-41-00-00A-010A-A	Access doors and panels - General data	-
DM03 89-A-11-00-01-00A-720A-A	Decal - Install procedure	-
DM04 89-A-20-00-00-00A-711A-A	Threaded fasteners - Tighten procedure	-
DM05 89-D-93-51-00-00A-320A-A	Thermal imaging (SAFIRE 380 HDC) system kit - Operation test	-

### 2) ACRONYMS & ABBREVIATIONS

AMD	Aircraft Material Data Information
AMMC	Aircraft Mission Management Computer
AMP	Aircraft Maintenance Publication
AR	As Required
ATA	Air Transport Association
C/A	Cable Assy
CDS	Cockpit Display System
DM	Data Module
DOA	Design Organization Approval
EASA	European Aviation Safety Agency
FLIR	Forward Looking Infra-Red
FWD	Forward
HCU	Hand Control Unit
HD	High Definition
IPD	Illustrated Parts Data
ITEP	Illustrated Tool and Equipment Publication
LH	Leonardo Helicopters
LIU	Laser Interlock Unit
MMH	Maintenance Man Hours
PCU	Panel-Mounted Control Unit
P/N	Part Number
RFM	Rotorcraft Flight Manual
S/N	Serial Number



TFU        Turret FLIR Unit  
UHCU      Universal Hand Control Unit

### **3) ANNEX**

N.A.

## **J. PUBLICATIONS AFFECTED**

AW189 IPD

AW189 AMP

AW189 RFM

## **K. SOFTWARE ACCOMPLISHMENT SUMMARY**

Software to be updated:

AMMC option file P/N 8G4620AO1XXX;

CDS option file P/N 8G4630AO1XXX.

Option File P/N is depending upon helicopter configuration that can be different from the one reported in relevant helicopter “Commissa di Vendita”. Customer must contact Product Support Engineering ([engineering.support.lhd@leonardo.com](mailto:engineering.support.lhd@leonardo.com)) to request the correct Option File at least three months in advance from the scheduled embodiment of this Service Bulletin.

<u>SW DESCRIPTION</u>	<u>S/N HELICOPTER</u>	
	<u>P/N SW INSTALLED</u> <u>(COMPILED BY CUSTOMER)</u>	<u>P/N SW TO BE ORDERED</u> <u>(COMPILED BY LEONARDO COMPANY)</u>
FCS LOADABLE SW		
AFDX CONFIG SWITCH		
AMMC DMG SW (if installed)		
AMMC OPSW		
AMMC OPTION FILE		
AMMC VAM SW		
CDS OPTION FILE		
DISPLAY UNIT SW		
DIMMER CONFIG FILE		
ECDU OP SW		
REPU CONFIG TABLE		
ICS SETTING FILE		

## 2. MATERIAL INFORMATION

### A. REQUIRED MATERIALS

#### 1) PARTS

#	P/N	ALTERNATIVE P/N	DESCRIPTION	Q.TY	LVL	NOTE	LOG P/N
1	8G9350F00611		KIT FLIR 380 HDC	REF	.		-
2	8G5310A50911		FLIR STAR SAFIRE 380 STRUCT REPLACEMENT	REF	..		-
3	8G9350A09431		Dummy stowage plate assy	1	...	(1)	189-316L1
4	8G5315A51931		Plate dummy stowage	1	...	(2)	189-316L1
5	8G5310A36911		FLIR STAR SAFIRE 380 STR PROVS	REF	..		-
6	8G9350P00451		Lower panel RH	1	...		189-316L1
7	8G9350P00531		Lower panel LH	1	...		189-316L1
8	A428A3C09		Screw	22	...		189-316L1
9	8G9350A09711		FLIR SAFIRE SS380-HDC EQUIPMENT INSTL	REF	..		-
10	4127344-1		Laser interlock unit (LIU)	1	...		189-316L1
11	4135364-2		Panel-mounted control unit (PCU)	1	...		189-316L1
12	ED300A121		Decal	1	...		189-316L1
13	ED300PL18		Decal	1	...		189-316L1
14	8G9350A11011		FLIR SAFIRE SS380 ELEC. REPLACEMENT	REF	..		-
15	AW001CL001-N6		Electrical Support	1	...		189-316L1
16	8G9350A12911		FLIR SS 380 HDC REMOVABLE PARTS	REF	..		-
17	QDD-1-1A		Lower assy complete	1	...		189-316L1
18	8G9350I00531		STAR SAFIRE SS380-HDC TURRET FLIR (TFU)	REF	...		-
19	A016A004B1		Plate identification	1	....		189-316L1
20	3290008-12		FLIR SS380HDC (TFU)	1	....		189-316L1
21	MS24673-12		Screw	8	...		189-316L1
22	MS35207-260		Screw	1	...		189-316L1
23	MS35207-263		Screw	1	...		189-316L1
24	NAS1149C0463R		Washer	8	...		189-316L1
25	NAS1149D0332J		Washer	3	...		189-316L1
26	8G9350A10451		Bonding strap	1	...		189-316L1
27	8G9350P01211		FLIR SS 380 RETRO MOD	REF	.		-
28	NAS6603-4		Bolt	1	..		189-316L1
29	NAS1149D0332J		Washer	1	..		189-316L1
30	8G9350A10231		Bracket assy	1	..		189-316L1
31	8G9350P01111		FLIR HDC PENDANT IN COCKPIT RELOCATION	REF	.		-
32	8G9350P01011		FLIR SS380-HDC U-HCU RELOCATION	REF	..		-
33	3204853-10		Universal hand control unit (UHCU)	1	...		189-316L1
34	ED300A227J1A		Decal	1	...		189-316L1
35	NAS1802-04-10		Screw	2	...		189-316L1
36	667-407XB15TOW- 59		Connector cover	1	...		189-316L1
37	ED300A227		Decal	1	...		189-316L1
38	3206461		FLIR pendant (Safire 380HD)	1	...		189-316L1
39	8G5310A53011		PENDANT RELOCATION	REF	..		-

#	P/N	ALTERNATIVE P/N	DESCRIPTION	Q.TY	LVL	NOTE	LOG P/N
<b>STRUCT PROVS</b>							
40	MS21043-04	MS21043-04N	Nut	4	...		189-316L1
41	NAS1802-04-7		Screw	4	...		189-316L1
42	AW014TZ-45-58		Washer	1	...		189-316L1
43	MS20426AD4-5		Rivet	0,1 kg	...		189-316L1
44	MS27039-1-08		Screw	1	...		189-316L1
45	MS27039-1-09		Screw	4	...		189-316L1
46	MS27039-1-10		Screw	6	...		189-316L1
47	NAS1149C0316R		Washer	10	...		189-316L1
48	NAS1149DN416J		Washer	8	...		189-316L1
49	8G9350A11731		Plate assy FLIR pendant relocation	1	...		189-316L1
50	8G9350A11531		Doubler FLIR pendant assy	1	...		189-316L1
51	8G9350A11331		Bracket FLIR pendant mount assy	1	...		189-316L1
52	8G9350A12851		Blanking plate	1	...		189-316L1
<b>53</b>	<b>8G9350P00911</b>		<b>RETROMOD FLIR SAFIRE SS380-HLD</b>	<b>REF</b>	.		-
54	8G9A22A38602	8G9A22A38602A1R	FLIR Safire SS380-HLD C/A (A2A386)	1	..		189-316L1
55	8G4620AO1XXX		AMMC option file	.	(3)(4)		-
56	8G4630AO1XXX		CDS option file	.	(3)(4)		-

Refer also to IPD for the spares materials required to comply with the AMP DMs referenced in the accomplishment instructions.

## 2) CONSUMABLES

The following consumable materials, or equivalent, are necessary to accomplish this Service Bulletin:

#	SPEC./LHD CODE NUMBER	DESCRIPTION	Q.TY	NOTE	PART
57	AWMS05-001 TY I, CL C, GR 1	Sealant MC-780 C (C465)	AR	(6)	-
58	AWMS05-001 TY I, CL B, GR 2	Sealant MC-780 B (C465)	AR	(6)	-
59	Code No. 99999999000017311	Corrosion preventive compound Cor-Ban 27L (C075)	AR	(6)	-
60	DTD 900AA/4488A	Corrosion preventive compound JC5A (C001)	AR	(5)(6)	-
61	Code No. 99999999000001675	Adhesive CB200-40 (C356)	AR	(6)	-
62	A236A01AB	Edging	AR	(6)(7)	-
63	EN6049-003-25-5	Tubing braided	AR	(6)(7)	-
64	EN6049-006-25-5	Tubing braided	AR	(6)(7)	-
65	MS20995C32	Lock wire	AR	(6)	-

Refer also to AMDI for the consumable materials required to comply with the AMP DM referenced in the accomplishment instructions.

## 3) LOGISTIC MATRIX

In order to apply this Service Bulletin, the following Logistic P/N can be ordered in accordance with the applicable notes:

LOGISTIC P/N	Q.TY (PER HELO)	NOTE	PART
189-316L1	1		-
8G4620AO1XXX	1	(3)(4)	-
8G4630AO1XXX	1	(3)(4)	-

**NOTE**

- (1) Item to be installed only if the Laser Interlock Unit (A121) P/N 4127344-1 is removed.
- (2) Item to be installed only if the Panel-Mounted Control Unit (PL18) P/N 4135364-2 is removed.
- (3) Option File P/N is depending upon helicopter configuration that can be different from the one reported in relevant helicopter “Commissa di Vendita” Customers must contact Product Support Engineering ([engineering.support.lhd@leonardo.com](mailto:engineering.support.lhd@leonardo.com)) to request the correct Option File at least three months in advance from the scheduled application of this Service Bulletin.
- (4) This software will not be supplied; as specified by Information Letter AW189-19-019 , it will be available for download, along with relevant certification document, in “My Software” sub-section of Leonardo AW Customer Portal website <https://leonardo.agustawestland.com>.
- (5) It is possible to use as alternative to Cor-Ban 27L.
- (6) Item to be procured as local supply.
- (7) Indicated P/N refer to a specific size. The last digits can be different based on the actual required installation.

**B. SPECIAL TOOLS**

The following special tools, or equivalent, are necessary to accomplish this Service Bulletin:

#	P/N	DESCRIPTION	Q.TY	NOTE	PART
66	Thorn-EMI BT51	Test meter	1	(B1)	-

Refer also to ITEP for the special tools required to comply with the AMP DM referenced in the accomplishment instructions.

**SPECIAL TOOLS NOTE**

- (B1) As alternative, use the test meter Evershed and Vignoles Ducter D201 or a suitable equivalent.

**C. INDUSTRY SUPPORT INFORMATION**

Customization.

### **3. ACCOMPLISHMENT INSTRUCTIONS**

#### **GENERAL NOTES**

- a) Place an identification tag on all components that are re-usable, including the attaching hardware that has been removed to gain access to the modification area and adequately protect them until their later re-use.
  - b) Shape the cables in order to prevent interference with the structure and the other existing installations, using where necessary suitable lacing cords and plastic cable tiedown.
  - c) Exercise extreme care during drilling operations to prevent instruments, cables and hoses damage.
  - d) After drilling, remove all swarf and sharp edges. Apply on bare metal a light film of primer unless the hole is used for ground connection.
  - e) During the installation of bonding braids or components requiring grounding, clean the surface structure in order to obtain a good ground contact.
  - f) Let adhesive cure at room temperature for at least 24 hours unless otherwise specified.
  - g) Exposed thread surface and nut must be protected using a layer of tectyl according to MIL-C-16173 grade I.
  - h) All lengths are in mm.
- 
1. In accordance with AMP DM 89-A-00-20-00-00A-120A-A, prepare the helicopter on ground for a safe maintenance. Disconnect the battery, all electrical power sources and/or the external power supply.
  2. With reference to Figure 7 View J2, if present, remove the FWD lower panel assy P/N 8G5331P06031 and n°22 screws P/N A428A3C09. Retain screws for later reuse.
  3. In accordance with AMP DM 89-A-06-41-00-00A-010A-A and with reference to Figures 6 and 7, remove all external panels, internal panels and internal liners as required to gain access to the area affected by the installation and perform the retromod FLIR Safire SS380-HLD P/N 8G9350P00911 as described in the following procedure:
    - 3.1 With reference to Figure 6 View J1, remove the FLIR Safire SS380-HLD

C/A (A2A386) P/N 8G9A22A38601.

**NOTE**

Use the edging P/N A236A on edges which are liable to cause damage to cable assemblies or where abrasion may occur.

**NOTE**

Install the tubing braided P/N EN6049-003 and/or P/N EN6049-006 where protection against chafing and prevention of contact with structure may occur, but the tubing protection is not substitute for good routing practice.

**NOTE**

When necessary replace existing clamp with suitable clamp.

- 3.2 With reference to Figure 6 View J1 and Figure 7 View J2, lay down the new FLIR Safire SS380-HLD C/A (A2A386) P/N 8G9A22A38602 on the existing route. Secure the cable assy by means of existing hardware and lacing cords as required.
- 3.3 With reference to Figure 7 View J2, perform electrical connection of the connector P171 (C/A A2A386) to the connector J171.
- 3.4 With reference to Figure 7 View J2, perform electrical connection of the connector P173 (C/A A2A386) to the connector J173.
4. In accordance with AMP DM 89-A-06-41-00-00A-010A-A and with reference to Figure 6, remove all external panels, internal panels and internal liners as required to gain access to the area affected by the installation and perform the FLIR SS 380 retro mod P/N 8G9350P01211 as described in the following procedure:
  - 4.1 With reference to Figure 6 View L and View M, drill the hole  $\varnothing 5.33 \div 5.45$  thru the FLIR mount assy P/N 8G9350A00431 in accordance with the dimensions shown. Restore the protective treatment of any cut-out edges.
  - 4.2 With reference to Figure 6 View M, temporarily locate the bracket assy P/N 8G9350A10231 on the FLIR mount assy P/N 8G9350A00431. Clean and prepare the surface for electrical bonding.
  - 4.3 With reference to Figure 6 View M, install the bracket assy P/N 8G9350A10231 under the FLIR mount assy P/N 8G9350A00431 by means of the bolt P/N NAS6603-4 and the washer P/N NAS1149D0332J. Apply a fillet of sealant MC-780 B (C465) around the bracket assy P/N 8G9350A10231.

### NOTE

The resistance measured must not exceeds the value of  
2.5 milliohms.

- 4.4 Perform the bonding test by means of the test meter “Thorn-EMI BT51” in the indicated position.
5. In accordance with AMP DM 89-A-06-41-00-00A-010A-A and with reference to Figures 1 thru 5, remove all external panels, internal panels and internal liners as required to gain access to the area affected by the installation and perform FLIR HDC pendant in cockpit relocation P/N 8G9350P01111 as described in the following procedure:
  - 5.1 With reference to Figure 2 View A “Was”, remove the decal P/N ED300A227J1A from the interseat console extension near the connector A227J1A.
  - 5.2 With reference to Figure 4 View F, remove and retain for later reuse the flange P/N M85049/95-16A-A, n°4 screws P/N NAS1802-04-7 (retain only two screws) and n°4 washers P/N NAS620-4L from the interseat console extension.
  - 5.3 With reference to Figure 4 View F, disconnect the connector A227J1A together with the C/As A1A446 and A2A387 from the structure of the interseat console extension.
  - 5.4 With reference to Figure 2 View A “Was”, remove the cover P/N D38999/33W15R, the flange P/N M85049/95-16A-A, n°4 screws P/N NAS1802-04-7 and n°4 washers P/N NAS1149DN416J from the interseat console extension.
  - 5.5 With reference to Figure 2 View A “Was”, remove the bracket mounting UHCU P/N 8G5330A62451 and n°6 rivets P/N A297A04TW02.
  - 5.6 With reference to Figures 3 thru 5, perform pendant relocation struct provs P/N 8G5310A53011 as described in the following procedure:
    - 5.6.1 With reference to Figure 4 View B, install the blanking plate P/N 8G9350A12851 on the interseat console extension by means of n°4 screws P/N NAS1802-04-7, n°4 nuts P/N MS21043-04 and n°8 washers P/N NAS1149DN416J. Apply Cor-Ban 27L (C075).
    - 5.6.2 With reference to Figure 3 Detail D, drill n°6 holes  $\varnothing 5.33 \pm 5.45$  thru the structure of the interseat console extension in accordance with the dimensions shown.
    - 5.6.3 With reference to Figure 4 View F, temporarily locate the doubler FLIR pendant assy P/N 8G9350A11531 in its position on the interseat console extension in accordance with the existing holes.
    - 5.6.4 With reference to Figure 3 Detail D, drill n°4 holes  $\varnothing 3.32$  thru the structure of the interseat console extension and countersink 100° holes up to  $\varnothing 5.72$ .



- 5.6.5 With reference to Figure 3 Detail D, countersink 100° n°4 existing holes up to Ø5.72.
- 5.6.6 With reference to Figure 4 View F, install the doubler FLIR pendant assy P/N 8G9350A11531 on the interseat console extension by means of n°8 rivets P/N MS20426AD4-5. Apply sealant MC-780 C (C465).
- 5.6.7 With reference to Figure 5 View C, install the plate assy FLIR pendant relocation P/N 8G9350A11731 on the interseat console extension by means of its captive screws.
- 5.6.8 With reference to Figure 4 View B and Figure 5 View C, locate the bracket FLIR pendant mount assy P/N 8G9350A11331 on the interseat console extension.
- 5.6.9 With reference to Figure 4 View B, fix the bracket FLIR pendant mount assy P/N 8G9350A11331 to the doubler FLIR pendant assy P/N 8G9350A11531 and to the interseat console extension by means of n°6 screws P/N MS27039-1-10 and n°6 washers P/N NAS1149C0316R. Apply Cor-Ban 27L (C075).
- 5.6.10 With reference to Figure 5 View C, fix the bracket FLIR pendant mount assy P/N 8G9350A11331 to the plate assy FLIR pendant relocation P/N 8G9350A11731 by means of n°4 screws P/N MS27039-1-09 and n°4 washers P/N NAS1149C0316R.
- 5.6.11 With reference to Figure 5 View C, install the screw P/N MS27039-1-08 and the washer P/N AW014TZ-45-58 on the bracket FLIR pendant mount assy P/N 8G9350A11331.
- 5.7 With reference to Figures 3 thru 5, perform FLIR SS380-HDC U-HCU relocation P/N 8G9350P01011 as described in the following procedure:
  - 5.7.1 With reference to Figure 3 Detail E, drill n°1 hole Ø26.72 and n°4 holes Ø3.25 thru the structure of the interseat console extension in accordance with the dimensions shown.
  - 5.7.2 With reference to Figure 4 View F, clean and prepare the contact surface for electrical bonding.
  - 5.7.3 With reference to Figure 4 View F, relocate the connector A227J1A (previously disconnected) and the C/As A1A446 and A2A387 in the new position.
  - 5.7.4 With reference to Figure 4 View B and View F, connect the connector A227J1A to the structure and install the flange P/N M85049/95-16A-A (previously removed) and the cover P/N 667-407XB15T0W-59 by means of n°2 screws P/N NAS1802-04-10, n°2 screws

- P/N NAS1802-04-7 (previously removed) and n°4 washers P/N NAS620-4L (previously removed).
- 5.7.5 In accordance with AMP DM 89-A-11-00-01-00A-720A-A and with reference to Figure 5 View G, install the decal P/N ED300A227J1A near the connector A227J1A.
- 5.7.6 With reference to Figure 5 View G, install the universal hand control unit (A227) (UHCU) P/N 3204853-10 on the bracket FLIR pendant mount assy P/N 8G9350A11331.
- 5.7.7 With reference to Figure 5 View G, install the FLIR pendant (Safire 380HD) P/N 3206461 and connect the connector A227P1A to the connector A227J1A and the connector A227P1 to the UHCU (A227).
- 5.7.8 In accordance with AMP DM 89-A-11-00-01-00A-720A-A and with reference to Figure 5 View G, install the decal P/N ED300A227 near the UHCU (A227).
6. In accordance with AMP DM 89-A-06-41-00-00A-010A-A and with reference to Figures 1, 2, 5, 6 and 7, remove all external panels, internal panels and internal liners as required to gain access to the area affected by the installation and perform the kit FLIR 380 HDC P/N 8G9350F00611 as described in the following procedure:
- 6.1 With reference to Figure 7, perform the FLIR Safire SS380 electrical replacement P/N 8G9350A11011 as described in the following procedure:
- 6.1.1 With reference to Figure 7 View K, if necessary, install the electrical support P/N AW001CL001-N6 on the structure STA1125 by means of the adhesive CB200-40 (C356) in accordance with the dimensions shown.
- 6.1.2 With reference to Figure 7 View K, perform electrical connection of the connector CP101P2 (C/A A3A158) to the splitter CP101.
- 6.2 With reference to Figures 2 and 5, perform the FLIR Safire SS380-HDC equipment instl P/N 8G9350A09711 as described in the following procedure:
- 6.2.1 With reference to Figure 5 View G, install the laser interlock unit (LIU) (A121) P/N 4127344-1 in its position on the interseat console extension by means of its four captive screws. Perform electrical connections of the connector A121P2 (C/A A1A446) and the connector A121P3 (C/A A1A445) to the LIU (A121).
- 6.2.2 In accordance with AMP DM 89-A-11-00-01-00A-720A-A and with reference to Figure 5 View G, install the decal P/N ED300A121 on the structure of the interseat console in an area adjacent the LIU (A121).

- 6.2.3 With reference to Figure 2 View A “Becomes”, install the panel-mounted control unit (PCU) (PL18) P/N 4135364-2 in its position on the interseat console by means of its four captive screws. Perform electrical connection of the connector PL18P1 (C/A A2A387 and C/A A1A446) to the PCU (PL18).
- 6.2.4 In accordance with AMP DM 89-A-11-00-01-00A-720A-A and with reference to Figure 2 View A “Becomes”, install the decal P/N ED300PL18 on the structure of the interseat console in an area adjacent PCU (PL18).
- 6.3 With reference to Figures 1 and 6, perform the FLIR SS 380 HDC removable parts P/N 8G9350A12911 as described in the following procedure:
  - 6.3.1 With reference to Figure 1 Detail H, assemble the Star Safire SS380-HDC turret FLIR (TFU) (A124) P/N 8G9350I00531: install the plate identification P/N A016A004B1 in the indicated position on the FLIR SS380HDC (TFU) P/N 3290008-12.
  - 6.3.2 With reference to Figure 1 Detail H, install the lower assy complete P/N QDD-1-1A on the Star Safire SS380-HDC turret FLIR (TFU) P/N 8G9350I00531 by means of n°8 screws P/N MS24673-12 and n°8 washers P/N NAS1149C0463R.
  - 6.3.3 In accordance with AMP DM 89-A-20-00-00-00A-711A-A and with reference to Figure 1 Detail H, tighten the eight screws to the standard torque value with an applicable torque wrench.

**NOTE**

[The safety pin and the locking bolt are provided with the lower assy complete P/N QDD-1-1A.](#)

- 6.3.4 With reference to Figure 1 Detail H and Figure 6 View J1, carefully lift and install the lower assy complete P/N QDD-1-1A and the Star Safire SS380-HDC turret FLIR (TFU) (A124) P/N 8G9350I00531 on the upper bracket P/N QDD-10. Slowly turn the turret unit until the lower assy complete engages its interface on the structure fully. Install the safety pin to lock the position and tighten the locking bolt to prevent unwanted movement of the turret unit.
- 6.3.5 With reference to Figure 1 Detail H and Figure 6 View M, install the bonding strap P/N 8G9350A10451 and fix one end to the turret unit end by means of the screw P/N MS35207-260 and n°2 washers P/N NAS1149D0332J and the other end to the bracket assy

P/N 8G9350A10231 by means of the screw P/N MS35207-263 and the washer P/N NAS1149D0332J.

- 6.3.6 In accordance with AMP DM 89-A-20-00-00-00A-711A-A and with reference to Figure 6 View M, tighten the two screws to the standard torque value with an applicable torque wrench.

**NOTE**

Before the connections between the connectors and the turret unit, disconnect the connectors from their stowage positions.

- 6.3.7 With reference to Figure 6 View J1, perform the electrical connections of the connectors A124P1 (C/A A1A444), A124P2 (C/A A2A386), A124P3 (C/A A2A386) and A124P4 (C/A A3A158) to the Star Safire SS380-HDC turret FLIR (TFU) P/N 8G9350I00531. Safety the connectors by means of lock wire P/N MS20995C32.

- 6.4 With reference to Figure 7, perform the FLIR Star Safire 380 structural provision P/N 8G5310A36911 as described in the following procedure:

- 6.4.1 With reference to Figure 7 View J2, install the lower panel RH P/N 8G9350P00451 and the lower panel LH P/N 8G9350P00531 by means of n°22 screws P/N A428A3C09 (if present, use existing screws removed at step 2). Protect all fasteners by means of the corrosion preventive compound Cor-Ban 27L (C075).

- 6.4.2 In accordance with AMP DM 89-A-20-00-00-00A-711A-A and with reference to Figure 7 View J2, tighten the screws previously installed to the standard torque value with an applicable torque wrench.

7. Perform a pin-to-pin continuity check of all the electrical connections made.

**NOTE**

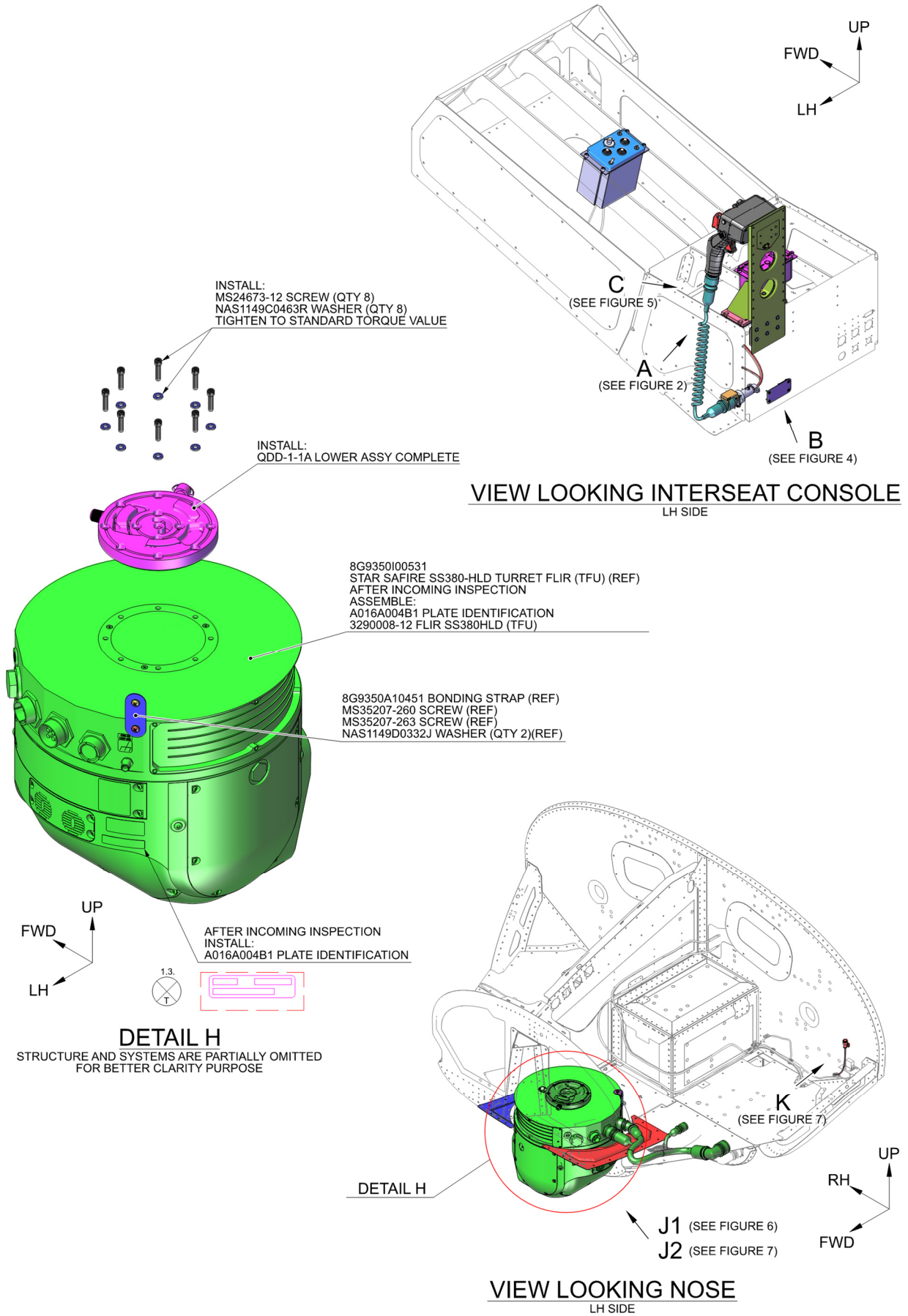
Customers must contact Product Support Engineering ([engineering.support.lhd@leonardo.com](mailto:engineering.support.lhd@leonardo.com)) to request the correct Option File at least three months in advance from the scheduled application of this Service Bulletin.

8. Install the AMMC option file P/N 8G4620AO1XXX and the CDS option file P/N 8G4630AO1XXX.
9. In accordance with DM AMP 89-D-93-51-00-00A-320A-A, perform the Thermal imaging (SAFIRE 380 HDC) operation test.
10. In accordance with AMP DM 89-A-06-41-00-00A-010A-A, reinstall all external panels, internal panels and internal liners previously removed.

11. In accordance with weight and balance changes, update the Chart A (see Rotorcraft Flight Manual, Part II, section 6).
12. Return the helicopter to flight configuration and record for compliance with this Service Bulletin on the helicopter logbook.
13. Send the attached compliance form to the following mail box:

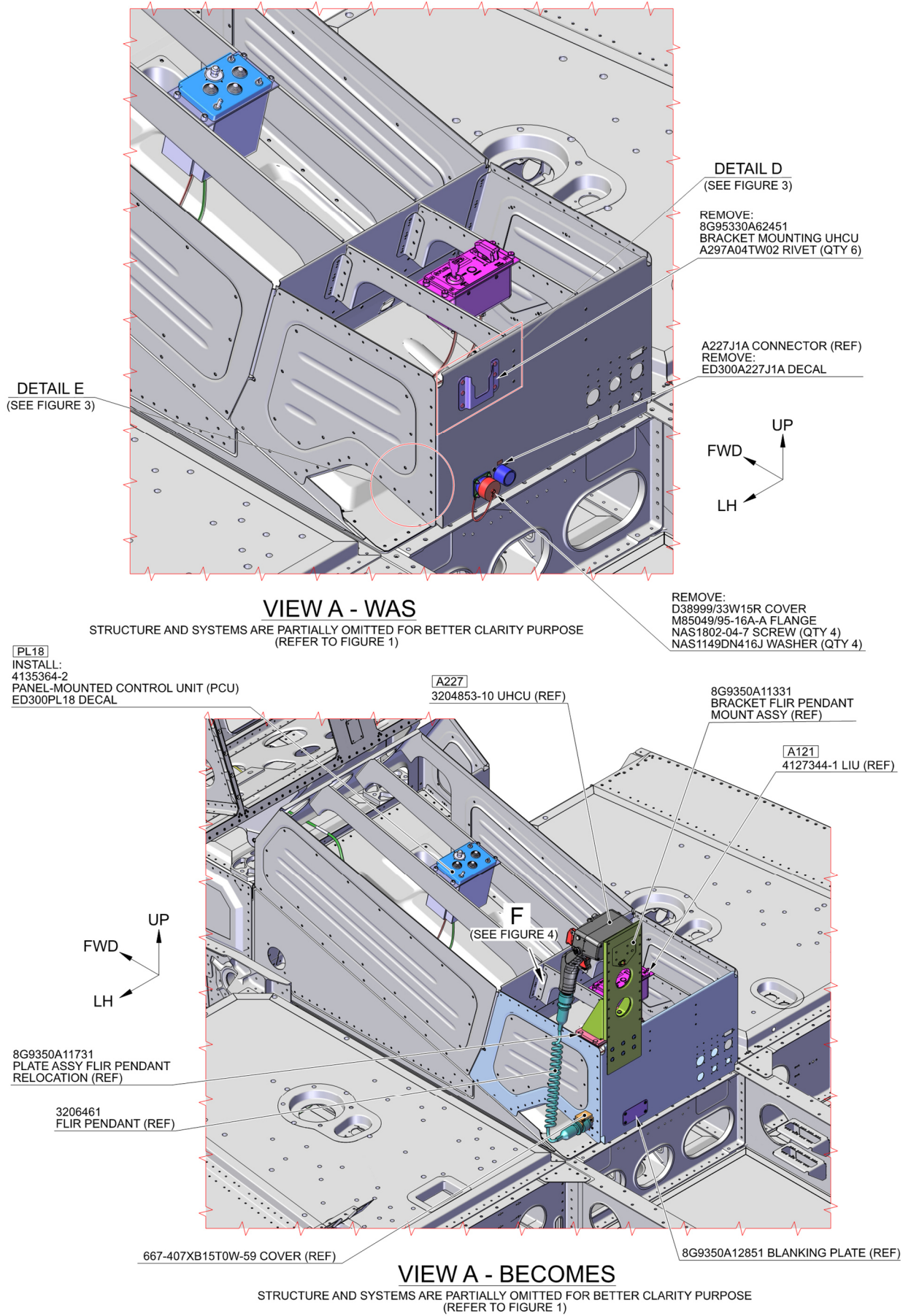
[engineering.support.lhd@leonardo.com](mailto:engineering.support.lhd@leonardo.com)

As an alternative, gain access to My Communications section on Leonardo WebPortal and compile the "Service Bulletin Application Communication".

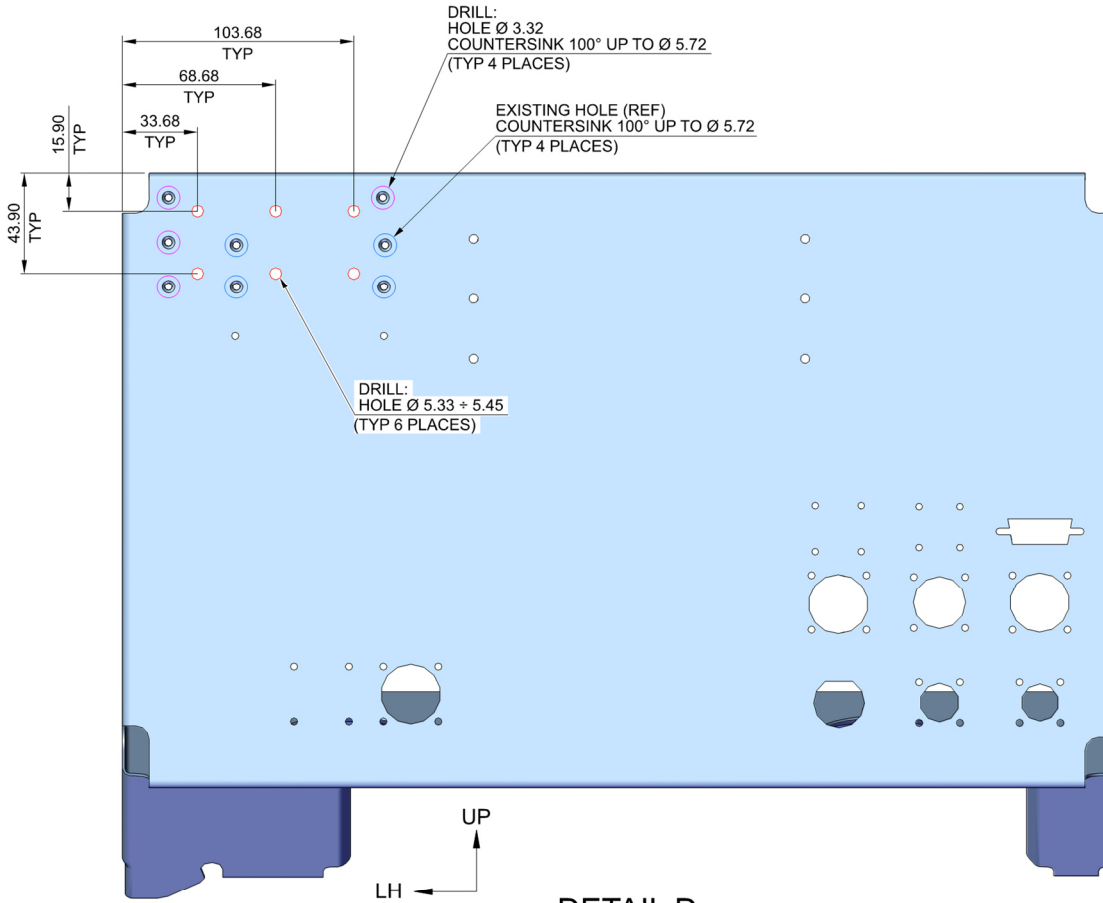


**Figure 1**



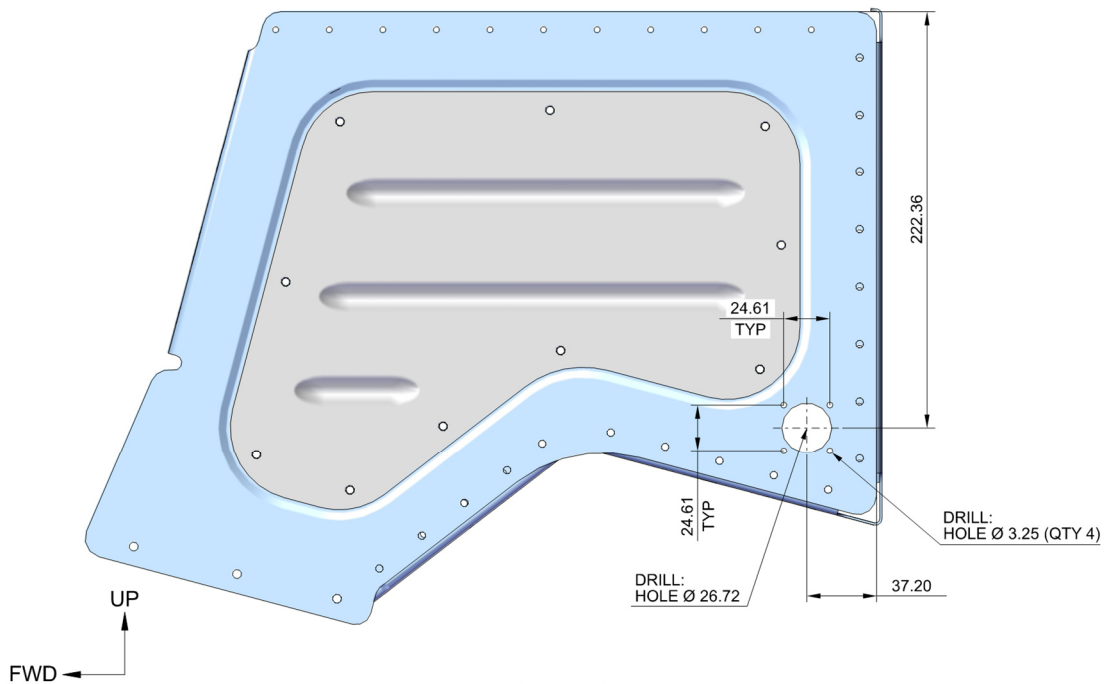


**Figure 2**



**DETAIL D**

STRUCTURE AND SYSTEMS ARE PARTIALLY OMITTED FOR BETTER CLARITY PURPOSE  
(REFER TO FIGURE 2)

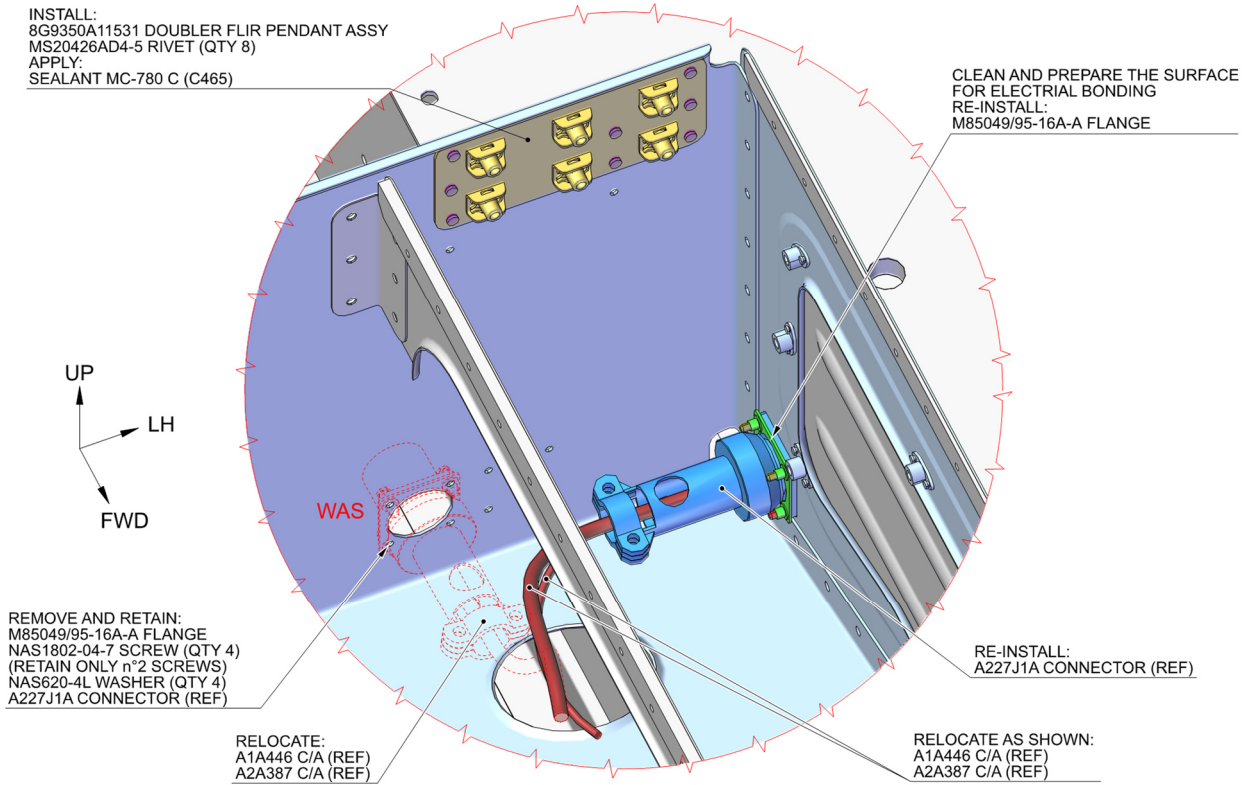


**DETAIL E**

STRUCTURE AND SYSTEMS ARE PARTIALLY OMITTED FOR BETTER CLARITY PURPOSE  
(REFER TO FIGURE 2)

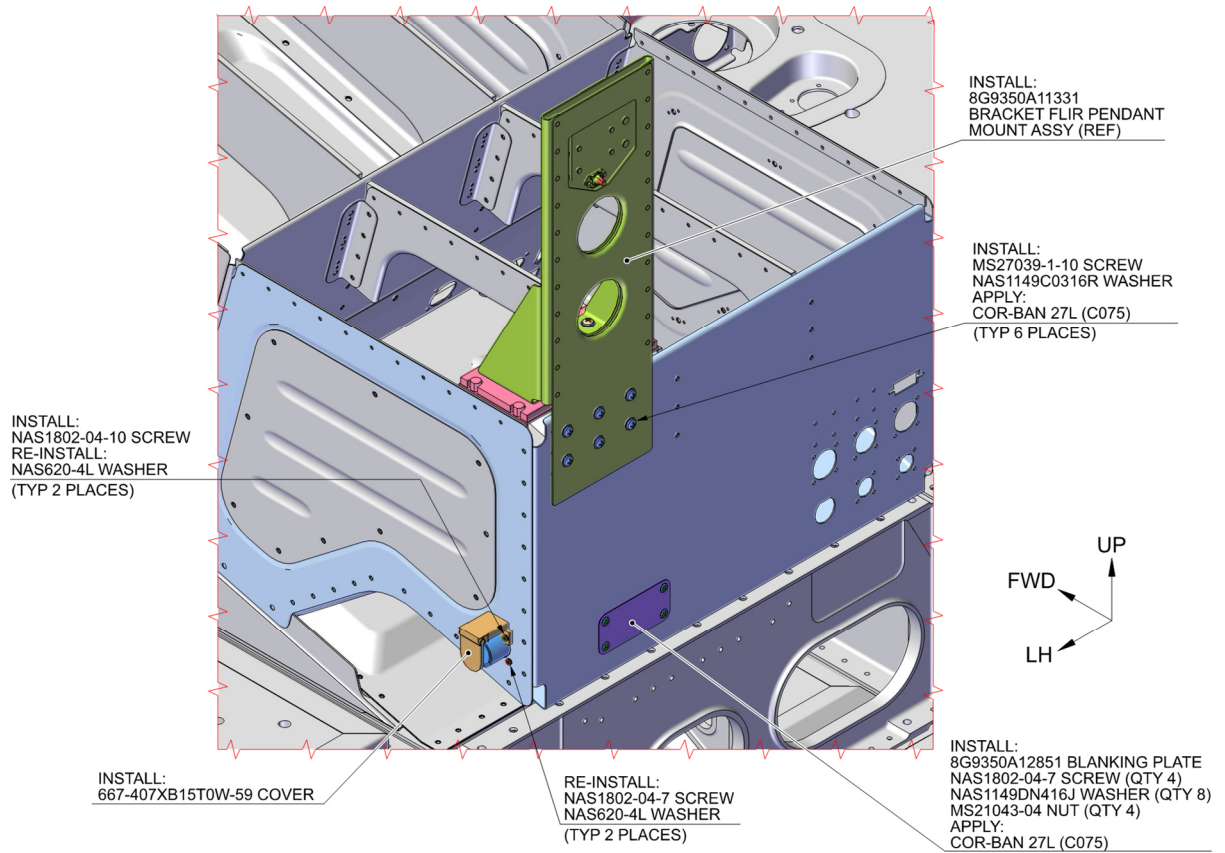
**Figure 3**





**VIEW F**

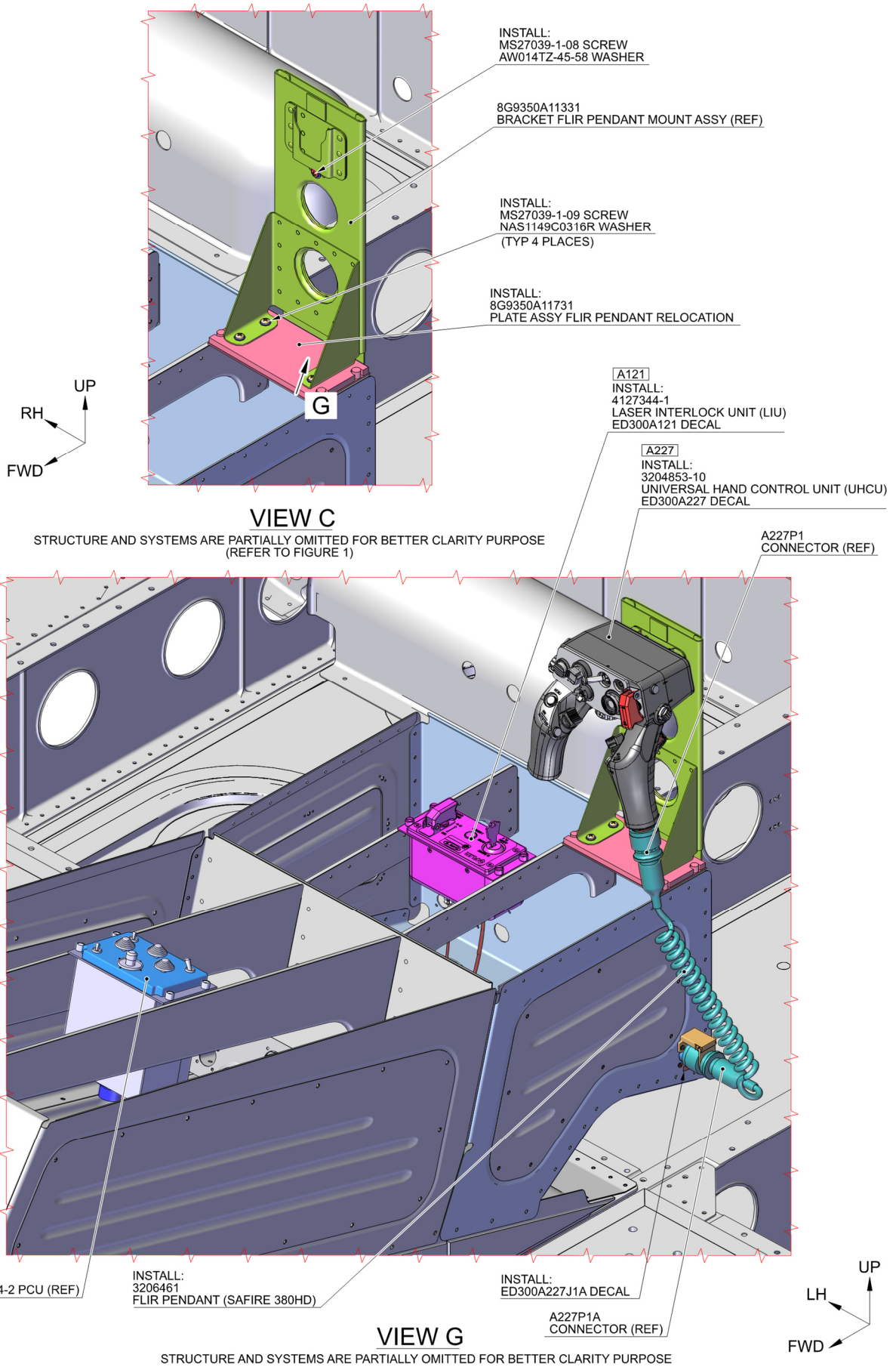
STRUCTURE AND SYSTEMS ARE PARTIALLY OMITTED FOR BETTER CLARITY PURPOSE  
(REFER TO FIGURE 2)



**VIEW B**

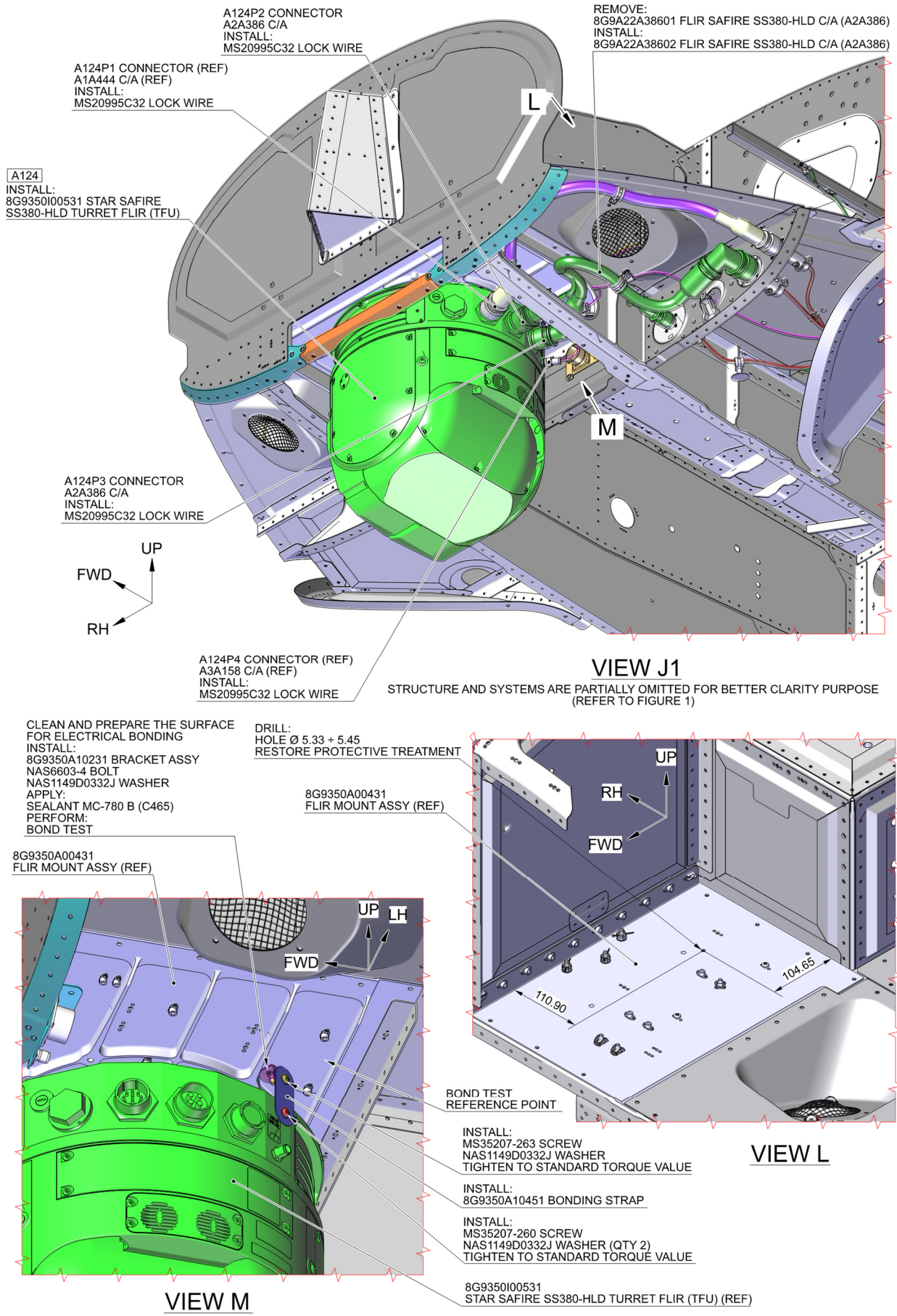
STRUCTURE AND SYSTEMS ARE PARTIALLY OMITTED FOR BETTER CLARITY PURPOSE  
(REFER TO FIGURE 1)

**Figure 4**



**Figure 5**





**Figure 6**

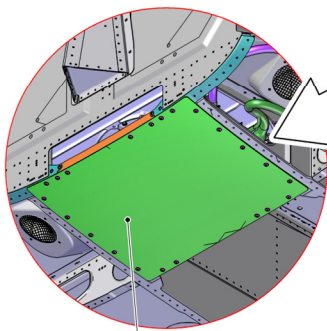
INSTALL:  
8G9350P00451 LOWER PANEL RH  
8G9350P00531 LOWER PANEL LH  
A428A3C09 SCREW (QTY 22)  
TIGHTEN TO STANDARD TORQUE VALUE  
APPLY:  
COR-BAN 27L (C075)

P171 CONNECTOR  
A2A386 C/A

P173 CONNECTOR  
A2A386 C/A

UP  
FWD  
RH

8G9350I00231  
STAR SAFIRE SS380-HLD TURRET FLIR (TFU)(REF)



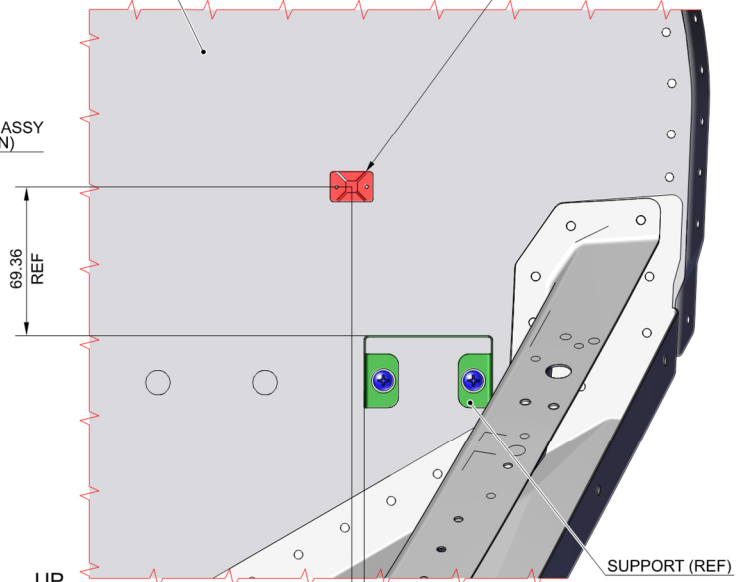
REMOVE (IF PRESENT):  
8G5331P06031 FWD LOWER PANEL ASSY  
A428A3C09 SCREW (QTY 22)(RETAIN)

**VIEW J2**

STRUCTURE AND SYSTEMS ARE PARTIALLY OMITTED FOR BETTER CLARITY PURPOSE  
(REFER TO FIGURE 1)

CP101P2 CONNECTOR (REF)  
A3A158 C/A (REF)  
INSTALL (IF NECESSARY):  
AW001CL001-N6 SUPPORT  
APPLY:  
ADHESIVE CB200-40 (C356)

STA 1125



UP  
RH

**VIEW K**

STRUCTURE AND SYSTEMS ARE PARTIALLY OMITTED FOR BETTER CLARITY PURPOSE  
(REFER TO FIGURE 1)

**Figure 7**

