SERVICE BULLETIN

N° 189-279

DATE: February 4, 2021

REV. : /

TITLE

ATA 25 - EMERGENCY LIFE-RAFT SYSTEM, ONE-TIME INSPECTION OF ACTUATION SYSTEM

REVISION LOG

First Issue

An appropriate entry should be made in the aircraft log book upon accomplishment.
If ownership of aircraft has changed, please, forward to new owner.

1. PLANNING INFORMATION

A. EFFECTIVITY

All AW189 helicopters equipped with the life raft assemblies LH/RH listed below not already marked with Aero Sekur Service Bulletin SB-189-25-009 on component label and logcard.

All the life raft assemblies LH/RH kept in stock and listed below not already marked with Aero Sekur Service Bulletin SB-189-25-009 on component label and logcard.

Description	P/N (Vendor P/N)	S/N affected
Life raft assy LH	P/N 8G2560V00131 (P/N 310844A)	up to S/N 00111 included (S/N 0108 excluded)
Life raft assy RH	P/N 8G2560V00231 (P/N 310845A)	up to S/N 00102 included (S/N's 00078, 00097 and 00098 excluded)

B. COMPLIANCE

Within and not later than 100 flight hours or 2 months whichever occurs first after the issue of this Service Bulletin.

For life raft assemblies kept in stock, before installation on helicopter.

C. CONCURRENT REQUIREMENTS

N.A.

D. REASON

This Service Bulletin is issued in order to provide the necessary instruction on how to perform a one-time inspection of the raft actuation system of the ELS.

E. DESCRIPTION

A case of incorrect installation of the raft actuation system of the AW189 ELS during the production process has been reported, this potentially leading to a missed activation of the raft when required.

This SB, jointly with Supplier's SB-189-25-009, has been issued in order to provide the relevant instructions on how to perform a one-time inspection of the activation pulley installation and, in case of findings, on how to restore the correct configuration on all the potentially affected AW189 helicopters.

F. APPROVAL

The technical content of this Service Bulletin is approved under the authority of DOA nr. EASA.21.J.005. For helicopters registered under other Aviation Authorities, before applying the Service Bulletin, applicable Aviation Authority approval must be checked within Leonardo Helicopters customer portal.

EASA states mandatory compliance with inspections, modifications or technical directives and related time of compliance by means of relevant Airworthiness Directives.

If an aircraft listed in the effectivity embodies a modification or repair not LHD certified and affecting the content of this Service Bulletin, it is responsibility of the Owner/Operator to obtain a formal approval by Aviation Authority having jurisdiction on the aircraft, for any adaptation necessary before incorporation of the present Service Bulletin.

G. MANPOWER

To comply with this Service Bulletin 0.5 MMH are deemed necessary.

MMH are based on hands-on time and can change with personnel and facilities available.

H. WEIGHT AND BALANCE

N.A.

I. REFERENCES

1) PUBLICATIONS

<u>DATA MODULE</u>	<u>DESCRIPTION</u>	<u>PART</u>
DM01 89-A-00-20-00-00A-120A-A	Helicopter on ground for a safe maintenance.	-
DM02 89-A-25-63-01-00A-520A-A	Left forward upper fairing - Remove procedure	-
DM03 89-A-25-63-01-00A-720A-A	Left forward upper fairing - Install procedure	-
DM04 89-A-25-63-02-00A-520A-A	Left forward lower fairing - Remove procedure	-
DM05 89-A-25-63-02-00A-720A-A	Left forward lower fairing - Install procedure	-
DM06 89-A-25-63-03-00A-520A-A	Left life raft container - Remove procedure	-
DM07 89-A-25-63-03-00A-720A-A	Left life raft container - Install procedure	-

<u>DATA MODULE</u>	<u>DESCRIPTION</u>	<u>PART</u>
DM08 89-A-25-63-05-00A-520A-A	Right forward upper fairing - Remove procedure	-
DM09 89-A-25-63-05-00A-720A-A	Right forward upper fairing - Install procedure	-
DM10 89-A-25-63-06-00A-520A-A	Right forward lower fairing - Remove procedure	-
DM11 89-A-25-63-06-00A-720A-A	Right forward lower fairing - Install procedure	-
DM12 89-A-25-63-07-00A-520A-A	Right life raft container - Remove procedure	-
DM13 89-A-25-63-07-00A-720A-A	Right life raft container - Install procedure	-

Aero Sekur Component Maintenance Manual (CMM) 25-61-16, Rev.1,
dated 20 Dec. 2013.

2) ACRONYMS

AMP	Aircraft Maintenance Publication
AMDI	Aircraft Material Data Information
DM	Data Module
DOA	Design Organization Approval
EASA	European Aviation Safety Agency
ELS	Emergency Liferaft System
LH	Left Hand
LHD	Leonardo Spa Helicopters
ITEP	Illustrated Tools and Equipment Publication
MMH	Maintenance Man Hours
RH	Right Hand

3) ANNEX

Annex A Aero Sekur Service Bulletin SB-189-25-009.

J. PUBLICATIONS AFFECTED

N.A.

K. SOFTWARE ACCOMPLISHMENT SUMMARY

N.A.

2. MATERIAL INFORMATION

A. REQUIRED MATERIALS

1) PARTS

The parts required for compliance with this Service Bulletin are listed in Section 2.A of Aero Sekur SB-189-25-009 (refer to Annex A).

2) CONSUMABLES

The consumables required for compliance with this Service Bulletin are listed in Section 2.A of Aero Sekur SB-189-25-009 (refer to Annex A).

Refer also to AMDI for the consumable materials required to comply with the AMP DM referenced in the accomplishment instructions.

3) LOGISTIC MATRIX

N.A.

B. SPECIAL TOOLS

The special tools required for compliance with this Service Bulletin are listed in Section 2.B of Aero Sekur SB-189-25-009 (refer to Annex A).

Refer also to ITEP for the special tools required to comply with the AMP DM referenced in the accomplishment instructions.

C. INDUSTRY SUPPORT INFORMATION

Owners/Operators who comply with the instructions of this Bulletin, no later than the applicable date in the "Compliance section" will be eligible to receive REQUIRED MATERIALS on free of charge basis, except for Consumable Materials & Special Tools.

NOTE: Customers who fail to comply with the instructions in this bulletin before the compliance date are not eligible for the aforementioned special policy.

CASE 1: Customers who are authorized to implement the Bulletin have to contact directly the vendor according to procedure reported in the Aero Sekur SB-189-25-009 (refer to Annex A).

CASE 2: Customers who are NOT authorized to implement the Bulletin have to issue the relevant M.M.I.R. to Leonardo Warranty Administration Dpt. to activate the exchange process.

3. ACCOMPLISHMENT INSTRUCTIONS

GENERAL NOTES

- a) Place an identification tag on all components that are re-usable, including the attaching hardware that has been removed to gain access to the modification area and adequately protect them until their later re-use.

NOTE

For life raft assemblies LH/RH kept in stock, perform only Step 2 thru Step 4.

1. In accordance with AMP DM 89-A-00-20-00-00A-120A-A, prepare the helicopter on ground for a safe maintenance. Disconnect the battery, all electrical power sources and/or the external power supply.

NOTE

- Perform the following step 2 for both life raft assemblies LH and RH.
 - Refer to DM 89-A-25-63-01-00A-520A-A or 89-A-25-63-05-00A-520A-A to remove the LH or RH forward upper fairing from the helicopter
 - Refer to DM 89-A-25-63-02-00A-520A-A or 89-A-25-63-06-00A-520A-A to remove the LH or RH forward lower fairing from the helicopter.
 - Refer to applicable steps of DM 89-A-25-63-03-00A-520A-A or DM 89-A-25-63-07-00A-520A-A to remove the frontal plate cover P/N 310864B or P/N 310865B from the LH or RH life raft container.
2. In accordance with Section 3.B of the attached SB-189-25-009, get access to the life raft actuation system and perform the inspection procedure on the raft actuation cable and the upper pulley P/N 309774A. Refer to Annex A.

NOTE

- Refer to applicable steps of DM 89-A-25-63-03-00A-720A-A or DM 89-A-25-63-07-00A-720A-A to install the frontal plate cover P/N 310864B or P/N 310865B to the left or right life raft container.

- Refer to DM 89-A-25-63-02-00A-720A-A or 89-A-25-63-06-00A-720A-A to install the left or right forward lower fairing on the helicopter.
 - Refer to DM 89-A-25-63-01-00A-720A-A or 89-A-25-63-05-00A-720A-A to install the left or right forward upper fairing on the helicopter.
3. Remove all the tools and other items from the work area.
 4. Perform Section 3.C of the attached SB-189-25-009 to record the compliance with the Service Bulletin. Refer to Annex A.
 5. Return the helicopter to flight configuration.
 6. Send the attached compliance form to the following mail box:
engineering.support.lhd@leonardocompany.com

As an alternative, gain access to My Communications section on Leonardo WebPortal and compile the “Service Bulletin Application Communication”.

ANNEX A

AERO SEKUR SERVICE BULLETIN SB-189-25-009

1. PLANNING INFORMATION

A. TITLE

ATA 25 - Emergency Life-raft System: One-time inspection for Raft actuation system.

B. EFFECTIVITY

This Service bulletin applies to the units listed below:

P/N 310844A (Leonardo Helicopters P/N 8G2560V00131), up to S/N 00111 included (S/N 0108 excluded);

P/N 310845A (Leonardo Helicopters P/N 8G2560V00231), up to S/N 00102 included (S/N's 00078, 00097, 00098 excluded).

C. CONCURRENT REQUIREMENTS

N/A.

D. REASON

The purpose of this Service Bulletin is to require a one-time inspection of the raft actuation system.

E. DESCRIPTION

A case of incorrect installation of the raft actuation system on AW189 Emergency Liferaft System (ELS) has been reported, refer to Figure 1.

The Upper pulley P/N 309774A is a single component mounted specularly on both left-hand and right-hand ELS installations; this can lead to an incorrect installation of it and particular attention must be taken during assembly phase because its position on the Lower pulley varies for left-hand and right-hand installation. A not proper installation of the Upper pulley P/N 309774A and raft activation cable imply the incorrect functioning of the ELS in emergency condition.

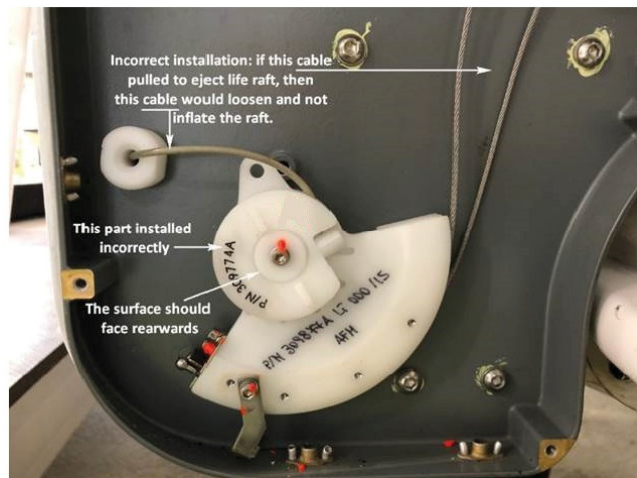

Figure 1 – Incorrect installation on the RIGHT AW189ELS

Original Issue – 10 November 2020

SB-189-25-009

Revision No.

Page 1 of 8

AERO SEKUR SpA, Customer Support, via delle Valli, 04011, Aprilia (LT), ITALY, +39.06.97634000, Fax +39.06.9282849
Email: publications@sekur.aero

This Service Bulletin may be accomplished by Authorized helicopter maintenance personnel. It is understood that Trained operators (I level), Authorized Repair Shops (II level) and Manufacturer (III level) are entitled to accomplish this Service Bulletin, where required.

F. COMPLIANCE:

MANDATORY. This service Bulletin shall be accomplished:

- For equipment (refer to paragraph 1.B) held as spares or in the repair loop, before next installation on aircraft.
- For equipment (refer to paragraph 1.B) in-service, refer to the helicopter Type Certificate Holder Service Bulletin.

A Service Bulletin published by AERO SEKUR Company may be recorded as "completed" in the appropriate Log Card only when the following general requirements are satisfied:

1. A mechanic must complete all of the instructions in the Service Bulletin, including the intent therein.
2. The mechanic must correctly use and install all applicable parts supplied with the Service Bulletin kit.
3. The mechanic must apply the information in the Service Bulletin only to items part number, serial number identified in the "Effectivity" section of the Bulletin.
4. The mechanic must use maintenance practices that are identified as acceptable standard practices in the aviation industry and governmental regulations.

AERO SEKUR Company is not responsible for the quality of maintenance performed to comply with this document, unless the maintenance is accomplished by AERO SEKUR or MRO facility approved by AERO SEKUR.

G. APPROVAL:

The content of this document is approved by Leonardo S.p.A. Helicopters (formerly Finmeccanica S.p.A., AgustaWestland S.p.A.), Design Authority of the AW189 Emergency Liferaft System.

H. MANPOWER:

Approximately 0.5 man-hours are required to complete this bulletin.

NOTE: This estimate is based on hands-on time, and may vary with personnel and facilities available.

NOTE: These labor-hours only concern the work described in this Service Bulletin and do not include other maintenance work which may be performed on this occasion.

I. WEIGHT AND BALANCE:

Not applicable.

J. REFERENCES:

- Aero Sekur Component Maintenance Manual (CMM) 25-61-16, Rev.1, dated 20 Dec. 2013.

K. PUBLICATION AFFECTED:

Not applicable.

2. MATERIAL INFORMATION

Original Issue – 10 November 2020

SB-189-25-009

Revision No.

Page 2 of 8

AERO SEKUR SpA, Customer Support, via delle Valli, 04011, Aprilia (LT), ITALY, +39.06.97634000, Fax +39.06.9282849
Email: publications@sekur.aero

A. MATERIAL

Table 1 lists materials required for compliance with this Service Bulletin.

PART NAME	P/N	SOURCE	USE
Sticky Label, for SB compliance marking	318502A	Aero Sekur	Optional use. Only when no space available on id. label.
Permanent Marker, Black	-	Local Supply	Consumable material for SB recording.

Table 1 - Materials

B. TOOLING

Table 2 lists tools required for compliance with this Service Bulletin.

PART NAME	P/N	SOURCE	USE
Wrench, allen, #2.5 mm	-	Local Supply	To remove/install the screw P/N V-G80044
Screwdriver, phillips, #2	-	Local Supply	To remove/install the screw P/N V-G60006

Table 2 - Tooling

C. INDUSTRY SUPPORT INFORMATION

Aero Sekur shall provide the materials in Table 1 (except for commercial and/or local supply material) on a free of charge basis for the Emergency Liferaft Systems listed in paragraph 1.B. No-charge purchase orders for these items must reference this Service Bulletin and must list (by part number and serial number) the units for which the items are to be used.

The equipment affected by this Service Bulletin and held in stock by Leonardo Helicopters are eligible for the accomplishment of this bulletin by Aero Sekur on a free of charge basis.

3. ACCOMPLISHMENT INFORMATION

WARNING: EXERCISE EXTREME CARE BY HOLDING THE RAFT ASSEMBLY AND PAY ATTENTION TO NOT PULL ITS ACTIVATION CABLE. THE HIGH PRESSURE IN THE CHARGED VESSEL MAY CAUSE AN UNEXPECTED FIRING OF THE SUBSYSTEM OR A LEAK OF HIGH-PRESSURE GAS MAY CAUSE INJURY TO PERSONNEL.

CAUTION: ALL INSTALLATIONS MUST BE HANDLED WITH EXTREME CARE DURING ALL WORKING PHASES. ANY OCCURRENCE WHICH MAY POTENTIALLY IMPACT THE EQUIPMENT INTEGRITY MUST BE REPORTED TO THE MAINTENANCE STAFF.

NOTE: Removing of the ELS from the helicopter is not necessary for the execution of the inspection described in this service bulletin.

NOTE: Instructions below (paragraphs 3.B) are applicable to all liferaft installations (Left-hand and Right-hand). The item part numbers for left-hand installation are written inside square brackets.

A. PRELIMINARY STEPS.

- (1) For storage ELS only, remove them from their packaging storage conditions.

B. RAFT ACTUATION SYSTEM: ONE-TIME INSPECTION PROCEDURE.

- (1) If the ELS is installed on the helicopter, remove the front Fairing unscrewing the screws that hold it on the ELS and helicopter; refer to the applicable Data Module of the Aircraft Maintenance Manual.
- (2) Remove the Frontal Plate Cover P/N 310865B [310864B], unscrewing the six screws P/N V-G60006, refer to the applicable Data Module of the Aircraft Maintenance Manual or DISASSEMBLY section of the CMM 25-61-16.
- (3) Lock the raft actuation system.
 - (a) Remove the Safety pin P/N G-C10005 located on the Frontal Plate from the flight configuration mode, Figure 2.
 - (b) Put the Safety pin P/N G-C10005 in maintenance configuration mode. Lock the pulley rotation, Inserting the Pin into the hole of the Lower Pulley P/N 309877A [309771A], refer to Figure 3.

WARNING: A NOT PROPER INSTALLATION OF THE UPPER PULLEY P/N 309774A AND RAFT ACTIVATION CABLE IMPLY THE INCORRECT FUNCTIONING OF THE LIFERAFT SYSTEM IN EMERGENCY CONDITION.

- (4) Visually inspect the installation of the raft actuation cable and the Upper pulley P/N 309774A, checking that:
 - (a) For Left Emergency Liferaft System, you must read the part number (P/N 309774A) of the Upper Pulley in case of correct installation; refer to Figure 4.
 - 1 If the raft actuation cable and the Upper pulley P/N 309774A are correctly installed as per Figure 4, skip to step (6).
 - 2 Otherwise, if you don't see the part number on the upper pulley, go to step (5).
 - (b) For Right Emergency Liferaft System, in case of correct installation, you cannot read the part number (P/N 309774A) of the Upper Pulley.
 - 1 If the raft actuation cable and the Upper pulley P/N 309774A are correctly installed as per Figure 5, skip to step (6).
 - 2 Otherwise if you see the part number on the upper pulley as, go to step (5).
- (5) In case of incorrect installation detected:
 - (a) If any, carefully remove the ELS from the helicopter according to the applicable Data Module of the Aircraft Maintenance Manual or DISASSEMBLY section of the CMM 25-61-16.

WARNING: AN ACCIDENTAL PULLING OF THE RAFT ACTUATION CABLE WILL INFLATE THE RAFT.

- (b) Remove the Locking cap P/N 309807A unscrewing the screw P/N V-G80044 and release the raft actuation cable from the Upper Pulley P/N 309774A. Ref to Figure 6.

(c) Remove the Main washer P/N 309773A from the Upper pulley P/N 309774A unscrewing the screws P/N V-G80044, with the grower P/N G-H20022 and the washers P/N G-H10063, ref. to Figure 7.

(d) Remove the Upper pulley P/N 309774A from the Main bush P/N 309772A and re-install the Upper pulley P/N 309774A as detailed in Figure 3 for left ELS and Figure 4 for right ELS.

1 Insert the raft actuation cable to the slot of the Upper Pulley P/N 309774A and secure it applying the Locking cap P/N 309807A by means of the screw P/N V-G80044.

CAUTION: ALWAYS TAKE CARE TO THE CABLE'S ROUTING ALONG PULLEYS. PULLING THE HANDLE SHALL LEAD TO TENSION ON THE RAFT ACTUATION CABLE.

CAUTION: FOR CABLE SLACK RECOVER, ROTATE THE UPPER PULLEY COUNTER CLOCKWISE FOR RIGHT ELS, OR CLOCKWISE FOR LEFT ELS.

CAUTION: WHEN THE RECOVER OF THE SLACK DOES NOT PERMIT THE COUPLING BETWEEN UPPER PULLEY AND LOWER PULLEY, DO NOT INSIST BUT ROTATES BACK THE UPPER PULLEY JUST ENOUGH TO ENGAGE THE PREVIOUS SLOT ON THE LOWER PULLEY.

2 Engage the dents of the Upper Pulley with the slots of the Lower Pulley. The raft actuation cable should be slightly in tension when the Upper Pulley P/N 309774A is installed on the Lower Pulley.

(e) Fix the Main Washer P/N 309773A on the Upper Pulley P/N 309774A by means of the screw P/N V-G80044, grower P/N G-H20022 and washers P/N G-H10063, Figure 7.

(6) Remove the Safety Pin P/N G-C10005 from the Lower Pulley P/N 309877A [309771A].

(7) Re-install the Frontal plate cover P/N 310865B [310864B], using the six screws P/N V-G60006; refer to the applicable Data Module of the Aircraft Maintenance Manual or ASSEMBLY section of the CMM 25-61-16.

(a) Restore the Safety Pin P/N G-C10005 in Transport or Flight configuration mode, refer to Figure 1.

(8) If necessary, install the ELS on the helicopter according to applicable Data Module of the Aircraft Maintenance Manual or ASSEMBLY section of the CMM 25-61-16.

(9) Install the front Fairing by means of screws that hold it on the ELS and helicopter; refer to the applicable Data Module of the Aircraft Maintenance Manual.

C. RECORD INSTRUCTION

(1) Write the service bulletin reference number (SB-189-25-009), wherever possible on the ELS Identification Label, to record compliance with this Service Bulletin.

NOTE: Where no space available on the identification label, use the "Sticky Label, for SB compliance marking" P/N 318502A to record the compliance (ref. to

paragraph 2.A). Apply the Sticky Label close to the Identification Label of the ELS.

- (2) Record compliance with this Service Bulletin in the component Log Card.

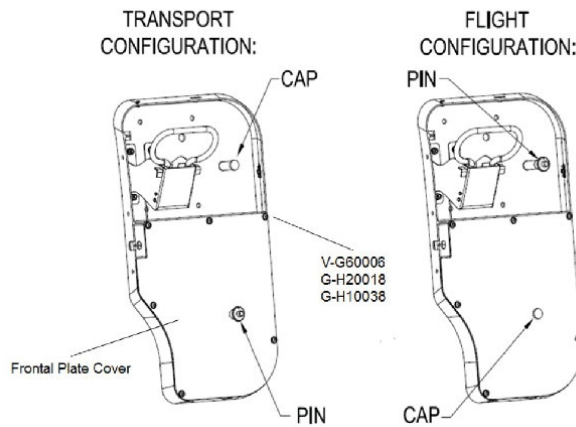

Figure 2 – Transport and flight configuration mode

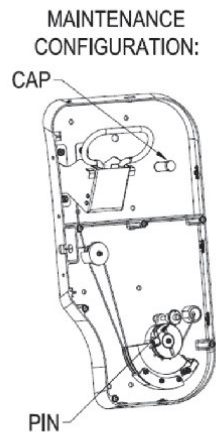

Figure 3 – Maintenance configuration mode

Original Issue – 10 November 2020

SB-189-25-009

Revision No.

Page 6 of 8

AERO SEKUR SpA, Customer Support, via delle Valli, 04011, Aprilia (LT), ITALY, +39.06.97634000, Fax +39.06.9282849
Email: publications@sekur.aero

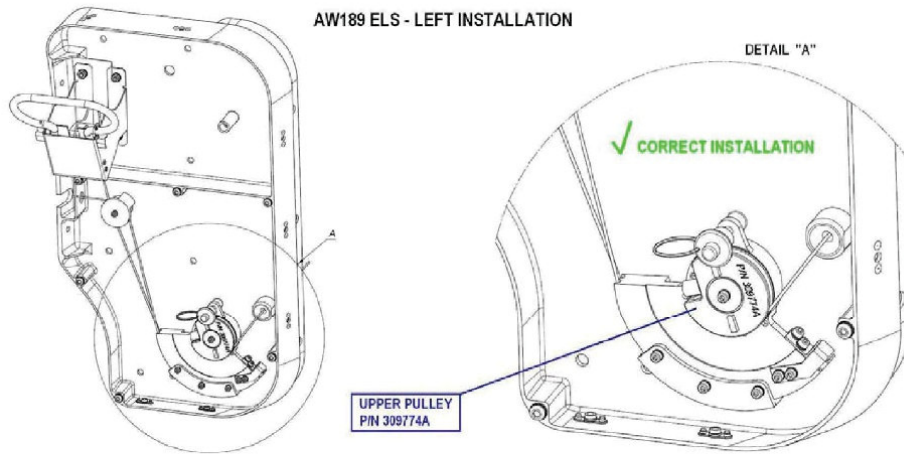

The marked part number is showed on the Upper Pulley surface: So, the Part number is in-sight.

Figure 4 – Correct installation on LEFT AW189ELS

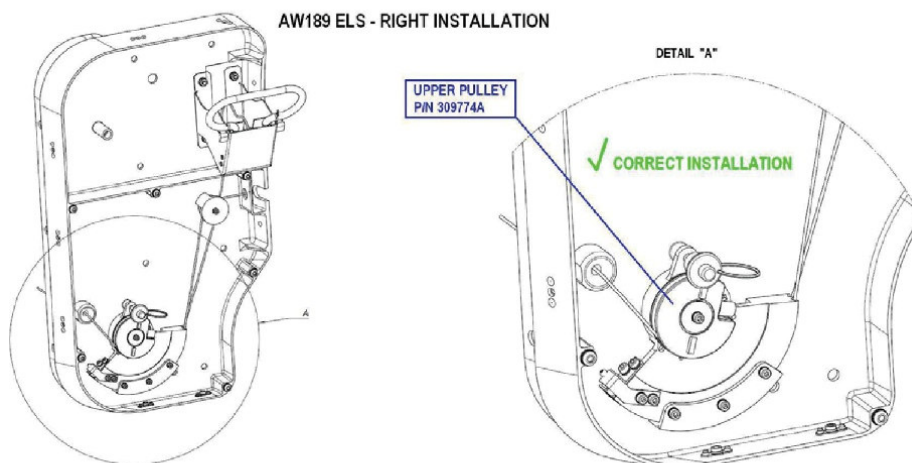

The item part number is marked on the Upper Pulley surface mating with Lower Pulley: So, the Part number is not in-sight.

Figure 5 – Correct installation on RIGHT AW189ELS

Original Issue – 10 November 2020

SB-189-25-009

Revision No.

Page 7 of 8

AERO SEKUR SpA, Customer Support, via delle Valli, 04011, Aprilia (LT), ITALY, +39.06.97634000, Fax +39.06.9282849
Email: publications@sekur.aero

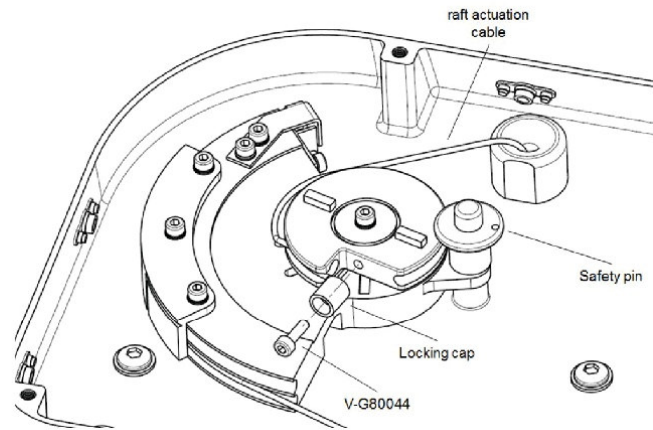

Figure 6 – Raft actuation cable release / locking

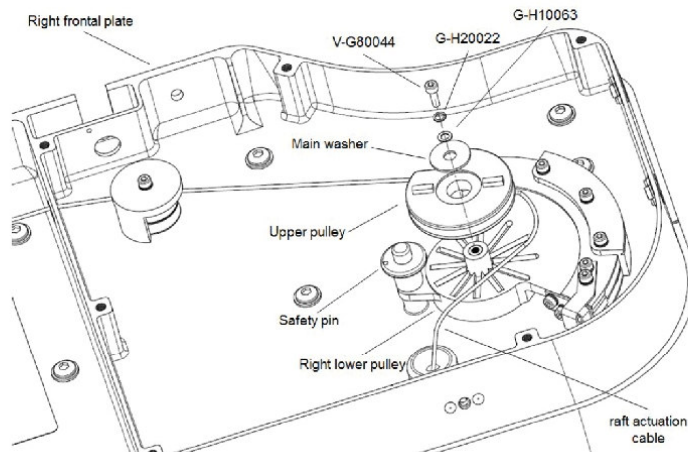

Figure 7 – Upper Pulley disassembly / assembly

Original Issue – 10 November 2020

SB-189-25-009

Revision No.

Page 8 of 8

AERO SEKUR SpA, Customer Support, via delle Valli, 04011, Aprilia (LT), ITALY, +39.06.97634000, Fax +39.06.9282849
 Email: publications@sekur.aero

Please send to the following address: LEONARDO S.p.A. CUSTOMER SUPPORT & SERVICES - ITALY PRODUCT SUPPORT ENGINEERING & LICENSES DEPT. Via Giovanni Agusta, 520 21017 Cascina Costa di Samarate (VA) - ITALY Tel.: +39 0331 225036 Fax: +39 0331 225988	SERVICE BULLETIN COMPLIANCE FORM	Date:
	Number:	
	Revision:	

Customer Name and Address:	Telephone:
	Fax:
	B.T. Compliance Date:

Helicopter Model	S/N	Total Number	Total Hours	T.S.O.

Remarks:

Information:

We request your cooperation in filling this form, in order to keep out statistical data relevant to aircraft configuration up-to-date. The form should be filled in all its parts and sent to the above address or you can communicate the application also via Technical Bulletin Application Communication Section placed in Leonardo AW Customer Portal - MyCommunications Area. We thank you beforehand for the information given.