SERVICE BULLETIN

N° 189-278

DATE: February 18, 2021

REV. : A - July 27, 2021

TITLE

ATA 21 - ECS ELECTRIC LINES CLIPPING MODIFICATION

REVISION LOG

Revision A of this SB has been issued to update the effectivity section excluding some helicopters that have a different ECS electrical installation layout.

An appropriate entry should be made in the aircraft log book upon accomplishment.
If ownership of aircraft has changed, please, forward to new owner.

1. PLANNING INFORMATION

A. EFFECTIVITY

All AW189 helicopters from S/N 49007 thru S/N 49067 (S/Ns 49024, 49036, 49040 and 49041 excluded), from S/N 89001 thru S/N 89012 (S/Ns 89005 and 89006 excluded) and from S/N 92001 to S/N 92010 equipped with ECS kit complete provision P/N 8G2150A03412.

AW189 helicopter S/N 89007 equipped with ECS kit complete provision P/N 8G2150A03411.

B. COMPLIANCE

Within and not later than 400 flight hours or 1 year whichever occurs first after the issue of this Service Bulletin.

C. CONCURRENT REQUIREMENTS

N.A.

D. REASON

This Service Bulletin is issued in order to provide the necessary instruction on how to perform the repositioning of the stud P/N A366A3E16C part of the electrical cables clipping of the ECS kit.

E. DESCRIPTION

Leonardo Helicopters identified a possible interference on the upper deck between the rotor brake hydraulic line and a stud which is part of the ECS kit electrical harness clipping.

This Service Bulletin gives instructions on how to change the ECS cable path, repositioning the stud in a new position and avoid any possibility of interference with the rotor brake pipe assy P/N 8G6352A00431.

F. APPROVAL

The technical content of this Service Bulletin is approved under the authority of DOA nr. EASA.21.J.005. For helicopters registered under other Aviation Authorities, before applying the Service Bulletin, applicable Aviation Authority approval must be checked within Leonardo Helicopters customer portal.

EASA states mandatory compliance with inspections, modifications or technical directives and related time of compliance by means of relevant Airworthiness Directives.

If an aircraft listed in the effectivity embodies a modification or repair not LHD certified and affecting the content of this Service Bulletin, it is responsibility of the Owner/Operator to obtain a formal approval by Aviation Authority having jurisdiction on the aircraft, for any adaptation necessary before incorporation of the present Service Bulletin.

G. MANPOWER

To comply with this Service Bulletin four (4) MMH are deemed necessary.

MMH are based on hands-on time and can change with personnel and facilities available.

H. WEIGHT AND BALANCE

N.A.

I. REFERENCES

1) PUBLICATIONS

<u>DATA MODULE</u>	<u>DESCRIPTION</u>	<u>PART</u>
DM01 89-A-00-20-00-00A-120A-A	Helicopter on ground for a safe maintenance	-
DM02 89-A-06-41-00-00A-010A-A	Access doors and panels - General data	-
DM03 89-A-20-10-16-02A-920A-A	Bonded studs - Replacement	-

2) ACRONYMS

AMDI	Aircraft Material Data Information
AMP	Aircraft Maintenance Publication
DM	Data Module
DOA	Design Organization Approval
EASA	European Aviation Safety Agency
ECS	Environmental Control System
ITEP	Illustrated Tool and Equipment Publication
LHD	Leonardo Helicopters Division
MMH	Maintenance Man Hours

3) ANNEX

N.A.

J. PUBLICATIONS AFFECTED

N.A.

K. SOFTWARE ACCOMPLISHMENT SUMMARY

N.A.

2. MATERIAL INFORMATION

A. REQUIRED MATERIALS

1) PARTS

#	P/N	ALTERNATIVE P/N	DESCRIPTION	Q.TY	LVL	NOTE	LOG P/N
1	A366A3E16C		Stud	1	.		-

2) CONSUMABLES

Refer to AMDI for the consumable materials required to comply with the AMP DM referenced in the accomplishment instructions.

3) LOGISTIC MATRIX

N.A.

B. SPECIAL TOOLS

Refer to ITEP for the special tools required to comply with the AMP DM referenced in the accomplishment instructions.

C. INDUSTRY SUPPORT INFORMATION

Warranty: Owners/Operators who comply with the instructions of this Service Bulletin no later than the applicable date in the "Compliance" section will be eligible to receive required materials on free of charge basis, except for Consumable Materials and Special Tools.

NOTE: Customers who fail to comply with the instructions in this Service Bulletin before the compliance date are not eligible for the aforementioned special policy.

Please Issue relevant MMIR form to your Warranty Administration Dpt..

3. ACCOMPLISHMENT INSTRUCTIONS

GENERAL NOTES

- a) Place an identification tag on all components that are re-usable, including the attaching hardware that has been removed to gain access to the modification area and adequately protect them until their later re-use.
 - b) Shape the cables in order to prevent interference with the structure and the other existing installations, using where necessary suitable lacing cords.
 - c) Let adhesive cure at room temperature for at least 24 hours unless otherwise specified.
 - d) All lengths are in mm.
-
1. In accordance with AMP DM 89-A-00-20-00-00A-120A-A, prepare the helicopter on ground for a safe maintenance. Disconnect the battery, all electrical power sources and/or the external power supply.
 2. In accordance with AMP DM 89-A-06-41-00-00A-010A-A and with reference to Figure 1, open the sliding cowling 451A and get access to the area affected to perform the repositioning of the stud P/N A366A3E16C:
 - 2.1 With reference to Figure 1 View A, remove and retain the clamp P/N AW001CB07H and its fixing hardware from the existing stud P/N A366A3E16C.
 - 2.2 In accordance with the applicable steps of AMP DM 89-A-20-10-16-02A-920A-A and with reference to Figure 1 View A, remove the stud P/N A366A3E16C from the upper deck panel.
 - 2.3 In accordance with the applicable steps of AMP DM 89-A-20-10-16-02A-920A-A and with reference to Figure 1 View A and View B, install the stud P/N A366A3E16C in the new position on the upper deck panel in accordance with the dimensions shown.
 - 2.4 With reference to Figure 1 View A, re-install the clamp P/N AW001CB07H previously removed on the stud P/N A366A3E16C by means of the existing hardware.
 3. Return the helicopter to flight configuration and record for compliance with this Service Bulletin on the helicopter logbook.

4. Send the attached compliance form to the following mail box:

engineering.support.lhd@leonardocompany.com

As an alternative, gain access to My Communications section on Leonardo WebPortal and compile the "Service Bulletin Application Communication".

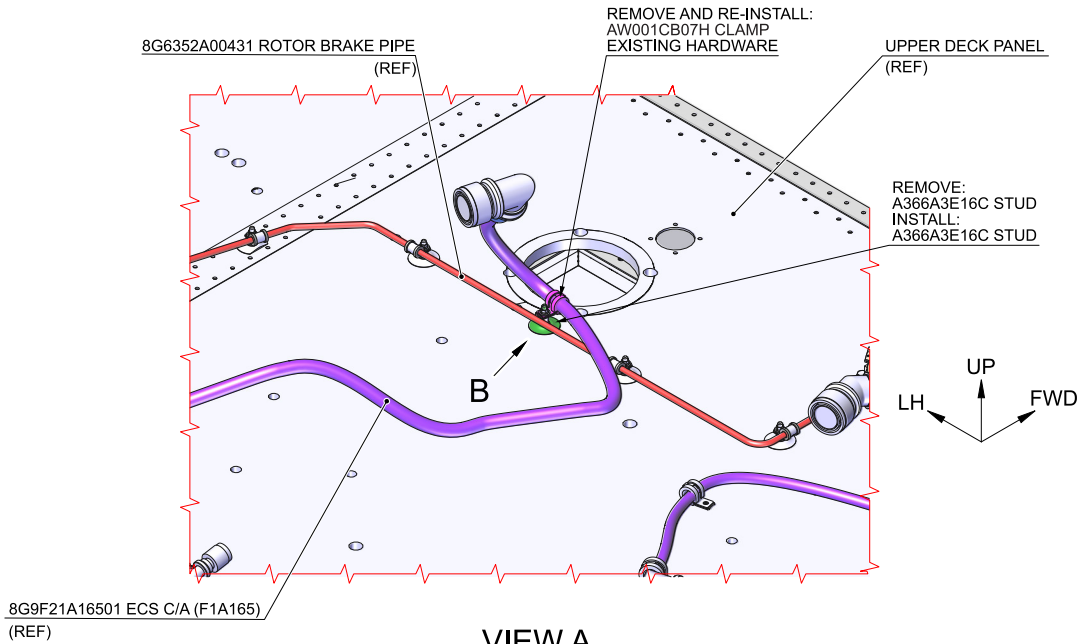
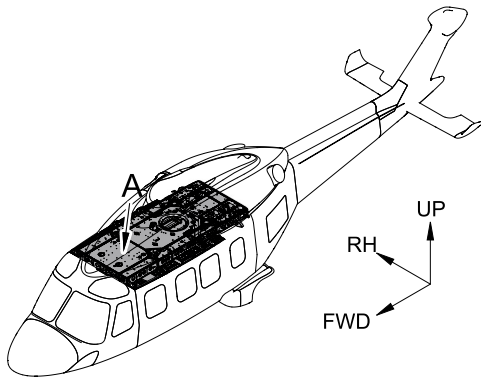

VIEW A

STRUCTURE AND SYSTEMS ARE PARTIALLY OMITTED FOR BETTER CLARITY PURPOSE

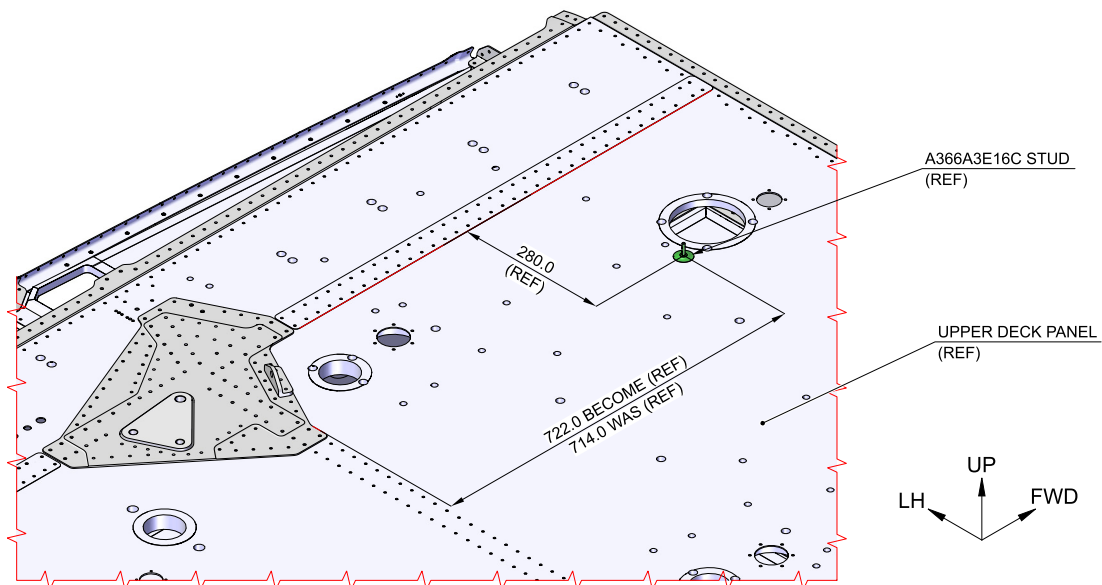

VIEW B

STRUCTURE AND SYSTEMS ARE PARTIALLY OMITTED FOR BETTER CLARITY PURPOSE

Figure 1

