

---

---

**SERVICE BULLETIN**

**N° 189-256**

**DATE:** March 22, 2023

**REV. :** /

---

---

**TITLE**

**ATA 71 – ENGINE COWLING LATCH RETROMOD**

**REVISION LOG**

First Issue

---

An appropriate entry should be made in the aircraft log book upon accomplishment.  
If ownership of aircraft has changed, please, forward to new owner.

---

## **1. PLANNING INFORMATION**

### **A. EFFECTIVITY**

All AW189 helicopters equipped with:

- “LH engine cowling assy” P/N 4F7110A21231 or 4F7110A21232 fitted with “rear LH latch box” P/N 4F7110A31651 and/or
- “RH engine cowling assy” P/N 4F7110A21331 or 4F7110A21332 fitted with “rear RH latch box” P/N 4F7110A40751.

All “LH engine cowling assy” P/N 4F7110A21231 or 4F7110A21232 fitted with “rear LH latch box” P/N 4F7110A31651 kept in stock.

All “RH engine cowling assy” P/N 4F7110A21331 or P/N 4F7110A21332 fitted with “rear RH latch box” P/N 4F7110A40751 kept in stock.

### **B. COMPLIANCE**

At Customer's option.

### **C. CONCURRENT REQUIREMENTS**

N.A.

### **D. REASON**

This Service Bulletin is issued in order to provide the necessary instructions on how to perform the “engine cowling latch retromod” P/N 8G7110P02311.

### **E. DESCRIPTION**

Leonardo Helicopters received reports about damages to the engine cowlings caused by an interference between the latches, when they are in fully opened position, and the cowling structure. The damage can be caused in case the latches were operated with excessive force.

Leonardo Helicopters developed a retromod to replace the existing engine cowlings rear latch boxes. The replacement is intended to repair existing damages and to prevent further occurrences to the engine cowlings rear latch box. The retromod gives all the necessary instructions on how to remove the damaged part of the cowling rear latch box assy and to install a new box with a different design, which does not allow any possibility of interference with the latches (also in fully opened position).

## F. APPROVAL

The technical content of this Service Bulletin is approved under the authority of DOA nr. EASA.21.J.005. For helicopters registered under other Aviation Authorities, before applying the Service Bulletin, applicable Aviation Authority approval must be checked within Leonardo Helicopters customer portal.

EASA states mandatory compliance with inspections, modifications or technical directives and related time of compliance by means of relevant Airworthiness Directives. If an aircraft listed in the effectivity embodies a modification or repair not LHD certified and affecting the content of this Service Bulletin, it is responsibility of the Owner/Operator to obtain a formal approval by Aviation Authority having jurisdiction on the aircraft, for any adaptation necessary before incorporation of the present Service Bulletin.

## G. MANPOWER

To comply with this Service Bulletin sixteen (16) MMH are deemed necessary.

MMH are based on hands-on time and can change with personnel and facilities available.

## H. WEIGHT AND BALANCE

N.A.

## I. REFERENCES

### 1) PUBLICATIONS

<u>DATA MODULE</u>	<u>DESCRIPTION</u>	<u>PART</u>
DM01 89-A-00-20-00-00A-120A-A	Helicopter on ground for a safe maintenance	-
DM02 89-A-06-41-00-00A-010A-A	Access doors and panels – General Data	-
DM03 89-A-71-11-02-00A-520A-A	Number 1 engine access door - Remove procedure	-
DM04 89-A-71-11-02-00A-720A-A	Number 1 engine access door - Install procedure	-
DM05 89-A-71-11-03-00A-520A-A	Number 2 engine access door - Remove procedure	-
DM06 89-A-71-11-03-00A-720A-A	Number 2 engine access door - Install procedure	-

## **2) ACRONYMS**

AMP	Aircraft Maintenance Publication
AR	As Required
DM	Data Module
DOA	Design Organization Approval
EASA	European Aviation Safety Agency
LHD	Leonardo Helicopters Division
MMH	Maintenance-Man Hours
IPD	Illustrated Parts Data

## **3) ANNEX**

N.A.

## **J. PUBLICATIONS AFFECTED**

N.A.

## **K. SOFTWARE ACCOMPLISHMENT SUMMARY**

N.A.

## 2. MATERIAL INFORMATION

### A. REQUIRED MATERIALS

#### 1) PARTS

#	P/N	ALTERNATIVE P/N	DESCRIPTION	Q.TY	LVL	NOTE	LOG P/N
1	8G7110P02311		ENGINE COWLING LATCH RETROMOD	REF	.		
2	8G7110P02031		LH LATCH BOX RETROMOD	REF	..		
3	8G7110A22151		LH rear latch box	1	...		189-256L1
4	8G7110P02131		RH LATCH BOX RETROMOD	REF	..		
5	8G7110A22251		RH rear latch box	1	...		189-256L1
6	A297A04TW01		Blind rivet	8	..		189-256L1
7	A297A04TW02		Blind rivet	24	..		189-256L1
8	NAS1399C3-2		Blind rivet	4	..		189-256L1
9	MS20615-3M6		Solid rivet	4	..		189-256L1

Refer also to IPD for the spares materials required to comply with the AMP DMs referenced in the accomplishment instructions.

#### 2) CONSUMABLES

Refer also to AMDI for the consumable materials required to comply with the AMP DM referenced in the accomplishment instructions.

#### 3) LOGISTIC MATRIX

In order to apply this Service Bulletin, the following Logistic P/N can be ordered in accordance with the applicable notes:

LOGISTIC P/N	Q.TY (PER HELO)	NOTE	PART
189-256L1	1	-	-

### B. SPECIAL TOOLS

N.A.

### C. INDUSTRY SUPPORT INFORMATION

N.A.

### **3. ACCOMPLISHMENT INSTRUCTIONS**

#### **GENERAL NOTES**

- a) Place an identification tag on all components that are re-usable, including the attaching hardware that has been removed to gain access to the modification area and adequately protect them until their later re-use.
  - b) Protect properly all those equipment not removed from area affected by the modification during installation procedure.
  - c) All lengths are in mm.
1. In accordance with AMP DM 89-A-00-20-00-00A-120A-A prepare the helicopter on ground for a safe maintenance. Disconnect the battery, all electrical power sources and/or the external power supply.

#### **NOTE**

The LH engine cowlings fitted with LH rear latch box P/N 8G7110A22151 do not require this retromod.

#### **NOTE**

If LH engine cowling assy is kept in stock perform only steps from 2.1.2 to 2.1.12.

2. With reference to Figures 1 and 2, gain access to the area affected and perform the engine cowling latch retromod P/N 8G7110P02311 as described in the following procedure:
  - 2.1 With reference to Figures 1 and 2, perform the LH latch box retromod P/N 8G7110P02031 as described in the following procedure:
    - 2.1.1 With reference to Figure 1 and in accordance with the applicable steps of AMP DM 89-A-71-11-02-00A-520A-A, open the LH engine cowling assy P/N 4F7110A21232 or P/N 4F7110A21231.
    - 2.1.2 In accordance with AMP DM 89-A-06-41-00-00A-010A-A and with reference to Figure 1 View A, remove and retain n°8 screws P/N A428A3C06T and the inspection door P/N 4F7110A31851 (Access panel 461E) from the LH engine cowling assy P/N 4F7110A21232 or P/N 4F7110A21231.
    - 2.1.3 With reference to Figure 1 View A, remove n°12 rivets P/N A297A04TW02 and n°4 rivets P/N A297A04TW01 from the LH engine cowling assy P/N 4F7110A21232 or P/N 4F7110A21231.

- 2.1.4 With reference to Figure 2 Section B-B, remove the LH rear latch box P/N 4F7110A31651 from the LH engine cowling assy P/N 4F7110A21232 or P/N 4F7110A21231.
- 2.1.5 With reference to Figure 1 View A and Figure 2 Views C and D, remove and retain the screw P/N MS27039-0834, the latch assy P/N A397A003A and the related nut plates from the existing LH rear latch box P/N 4F7110A31651.
- 2.1.6 With reference to Figure 2 Section B-B, remove and retain the LH rear latch support P/N 4F7110A25951 from the existing LH rear latch box P/N 4F7110A31651.
- 2.1.7 With reference to Figure 2 Section B-B, install on the new LH rear latch box P/N 8G7110A22151 the LH rear latch support P/N 4F7110A25951 previously removed.
- 2.1.8 With reference to Figure 2 View C, install on the LH rear latch box P/N 8G7110A22151 the nut plate P/N 4F7110A31451 and the nut plate P/N MS21070-08W by means of n°2 rivets P/N MS20615-3M6.
- 2.1.9 With reference to Figure 2 View D, install on the LH rear latch box P/N 8G7110A22151 the nut plate P/N 4F7110A31451 by means of n°2 rivets P/N NAS1399C3-2.
- 2.1.10 With reference to Figure 2 View D, re-install the latch assy P/N A397A003A in the same position on the LH rear latch box P/N 8G7110A22151 by means of the screw P/N MS27039-0834 previously removed.
- 2.1.11 With reference to Figure 1 View A and Figure 2 Section B-B, install on the LH engine cowling assy P/N 4F7110A21232 or P/N 4F7110A21231 the LH rear latch box P/N 8G7110A22151 and the related support by means of n°12 rivets P/N A297A04TW02 and n°4 rivets P/N A297A04TW01.
- 2.1.12 In accordance with AMP DM 89-A-06-41-00-00A-010A-A and with reference to Figure 1 View A, re-install the inspection door P/N 4F7110A31851 (access panel 461E) on the LH engine cowling assy P/N 4F7110A21232 or P/N 4F7110A21231 by means of the n°8 screws P/N A428A3C06T previously removed.
- 2.1.13 With reference to Figure 1 "Engine Cowling Assy" and in accordance with the applicable steps of AMP DM 89-A-71-11-02-00A-720A-A, close the LH engine cowling assy P/N 4F7110A21232 or P/N 4F7110A21231 on the helicopter.

**NOTE**

The RH engine cowlings fitted with RH rear latch box P/N 8G7110A22251 do not require this retromod.

**NOTE**

If LH engine cowling assy is kept in stock perform only step 2.2.2.

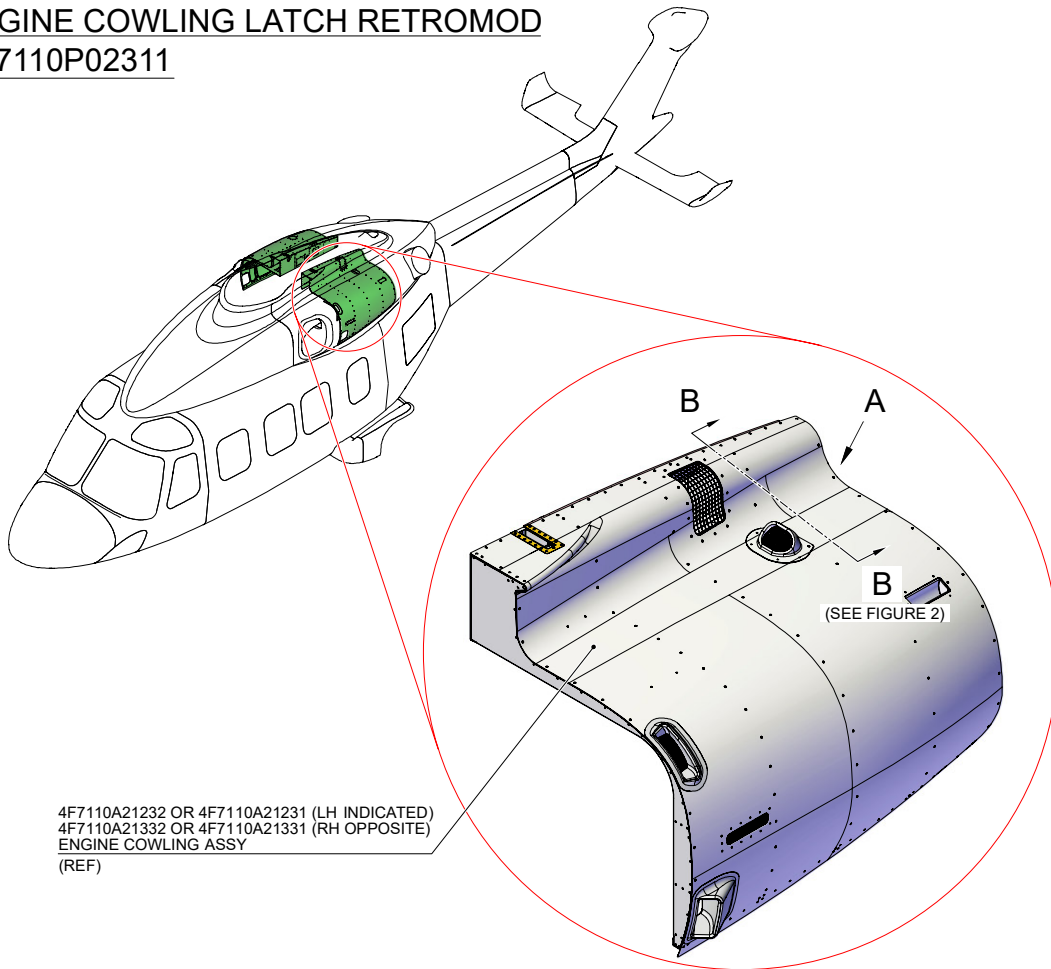
- 2.2 With reference to Figures 1 and 2, perform the RH latch box retromod P/N 8G7110P02131 as described in the following procedure:
  - 2.2.1 With reference to Figure 1 “Engine Cowling Assy” and in accordance with the applicable steps of AMP DM 89-A-71-11-03-00A-520A-A, open the RH engine cowling assy P/N 4F7110A21332 or P/N 4F7110A21331.
  - 2.2.2 Repeat steps from 2.1.2 thru 2.1.12 for the installation of the RH rear latch box P/N 8G7110A22251 on the RH engine cowling assy P/N 4F7110A21332 or P/N 4F7110A21331.
  - 2.2.3 With reference to Figure 1 “Engine Cowling Assy” and in accordance with the applicable steps of AMP DM 89-A-71-11-03-00A-720A-A, close the RH engine cowling assy P/N 4F7110A21332 or P/N 4F7110A21331 on the helicopter.
3. Return the helicopter to flight configuration and record for compliance with this Service Bulletin on the helicopter logbook.
4. Send the attached compliance form to the following mail box:

[engineering.support.lhd@leonardo.com](mailto:engineering.support.lhd@leonardo.com)

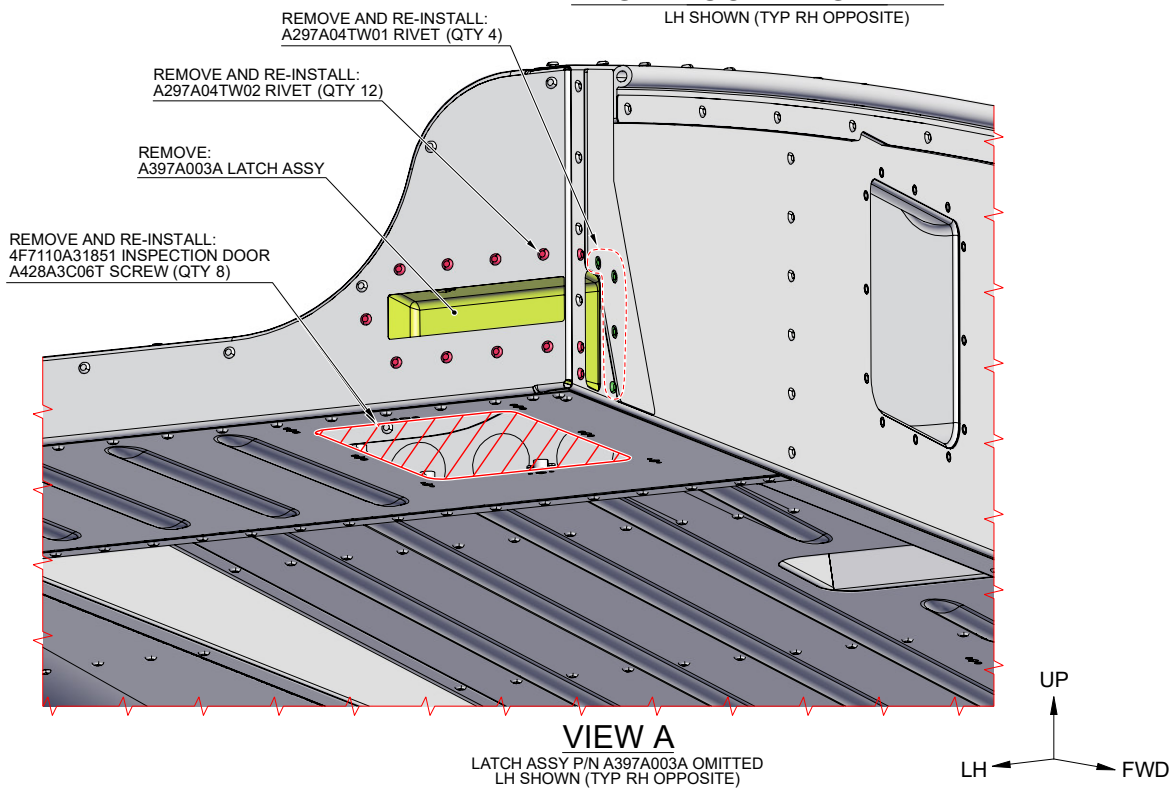
As an alternative, gain access to My Communications section on Leonardo WebPortal and compile the “Service Bulletin Application Communication”.



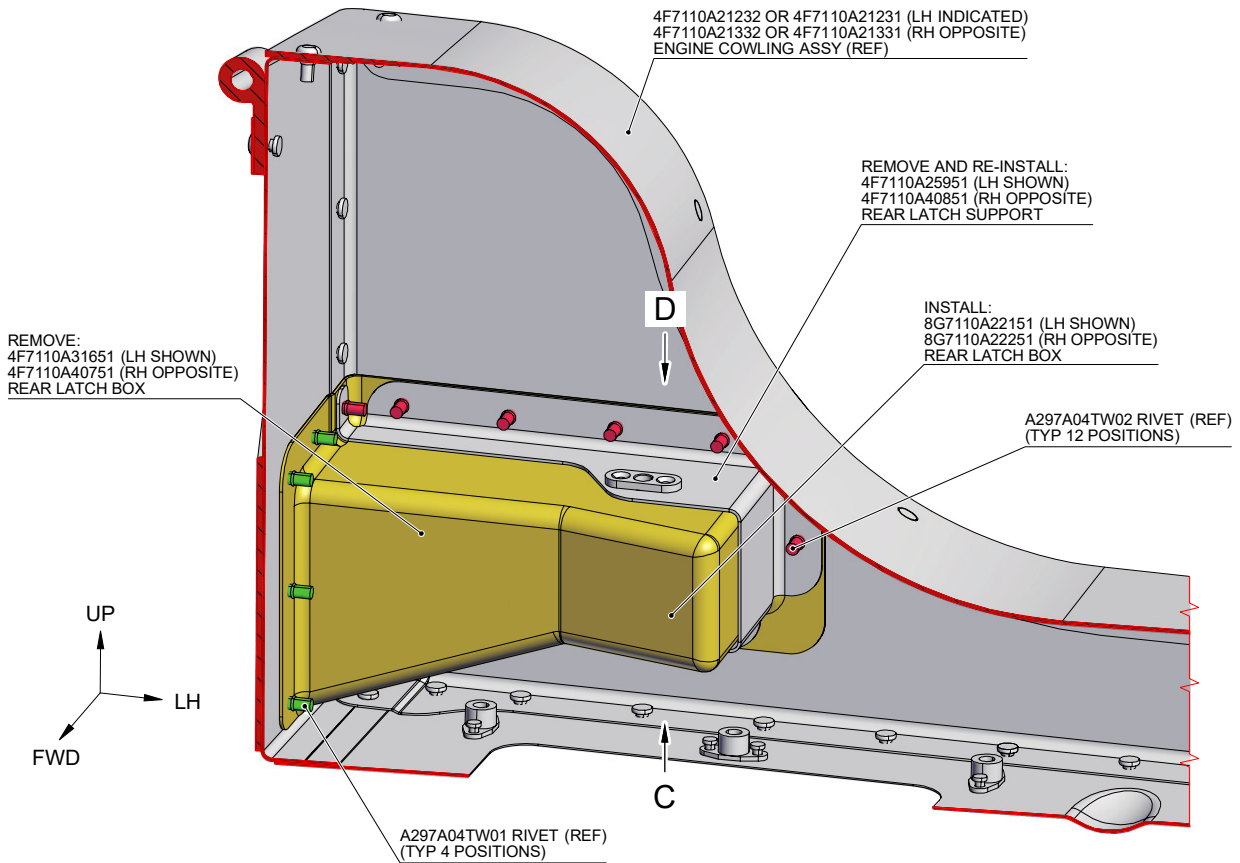
**ENGINE COWLING LATCH RETROMOD  
8G7110P02311**



**ENGINE COWLING ASSY**  
LH SHOWN (TYP RH OPPOSITE)

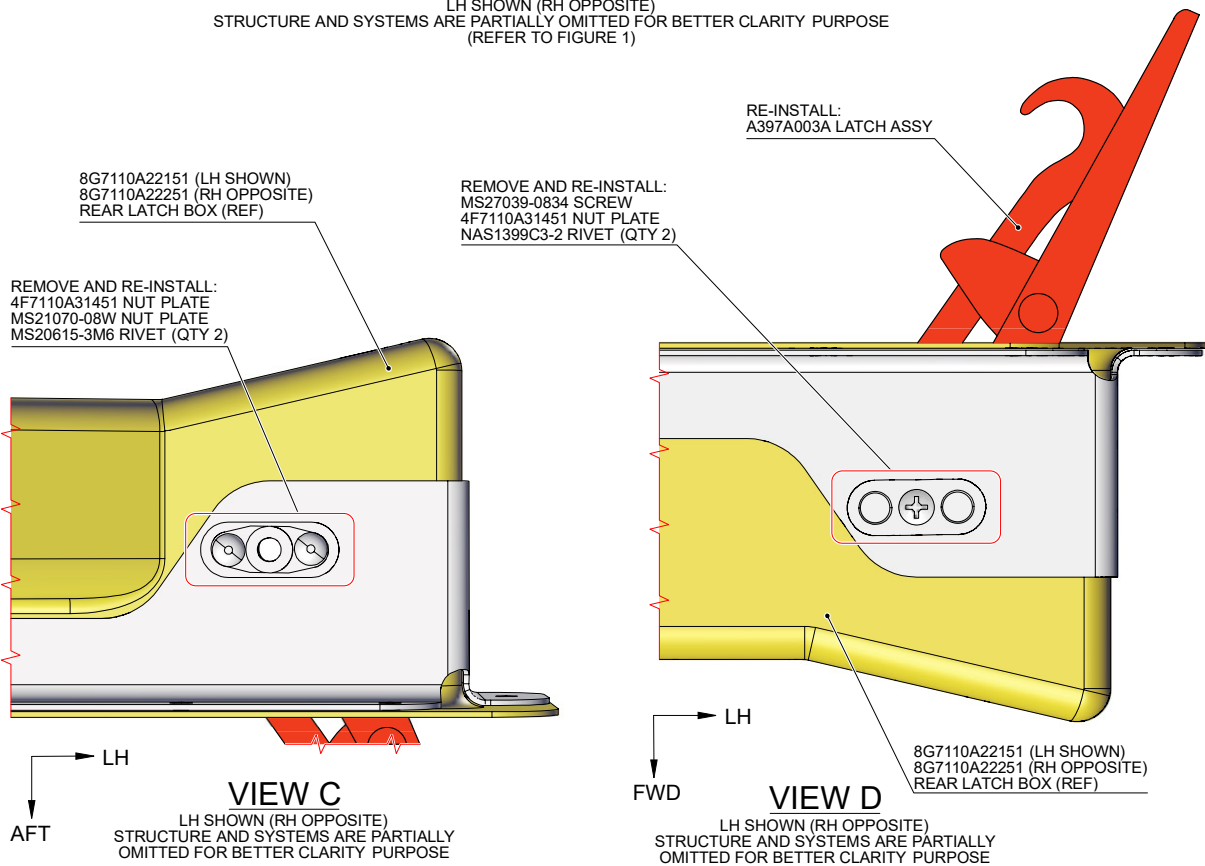


**Figure 1**



**SECTION B-B**

LH SHOWN (RH OPPOSITE)  
STRUCTURE AND SYSTEMS ARE PARTIALLY OMITTED FOR BETTER CLARITY PURPOSE  
(REFER TO FIGURE 1)



**Figure 2**

Please send to the following address:		<b>SERVICE BULLETIN COMPLIANCE FORM</b>		Date:	
<b>LEONARDO S.p.A.</b> <b>CUSTOMER SUPPORT &amp; SERVICES - ITALY</b>  <b>PRODUCT SUPPORT ENGINEERING &amp; LICENSES DEPT.</b> Via Giovanni Agusta, 520 21017 Cascina Costa di Samarate (VA) - ITALY Tel.: +39 0331 225036 Fax: +39 0331 225988		Number:			
		Revision:			
Customer Name and Address:			Telephone:		
			Fax:		
			B.T. Compliance Date:		
Helicopter Model	S/N	Total Number	Total Hours	T.S.O.	
Remarks:					
Information:					
We request your cooperation in filling this form, in order to keep out statistical data relevant to aircraft configuration up-to-date. The form should be filled in all its parts and sent to the above address or you can communicate the application also via Technical Bulletin Application Communication Section placed in Leonardo AW Customer Portal - MyCommunications Area. We thank you beforehand for the information given.					