SERVICE BULLETIN

N° 139-695

DATE: June 9, 2022

REV. : /

TITLE

ATA 56 - INSTALLATION OF ACRYLIC WINDSHIELDS

REVISION LOG

First Issue

An appropriate entry should be made in the aircraft log book upon accomplishment.
If ownership of aircraft has changed, please, forward to new owner.

1. PLANNING INFORMATION

A. EFFECTIVITY

All AB/AW139 helicopters from S/N 31005 onwards except S/N 31007 and from S/N 41001 onwards except S/N 41237.

B. COMPLIANCE

At Customer's option.

C. CONCURRENT REQUIREMENTS

N.A.

D. REASON

This Service Bulletin is issued in order to provide the necessary instructions on how to perform the installation of the kit acrylic windshields P/N 3G5610F00211.

E. DESCRIPTION

This Service Bulletin has been developed to provide the necessary instructions for the installation of the kit acrylic windshields P/N 3G5610F00211 and, only for helicopters equipped with kit IPS windshield installation P/N 4G3040A00411, the necessary instructions to remove left windshield P/N 4G5610V00131 and right windshield P/N 4G5610V00231.

F. APPROVAL

The technical content of this Service Bulletin is approved under the authority of DOA nr. EASA.21.J.005. For helicopters registered under other Aviation Authorities, before applying the Service Bulletin, applicable Aviation Authority approval must be checked within Leonardo Helicopters customer portal.

EASA states mandatory compliance with inspections, modifications or technical directives and related time of compliance by means of relevant Airworthiness Directives. If an aircraft listed in the effectivity embodies a modification or repair not LHD certified and affecting the content of this Service Bulletin, it is responsibility of the Owner/Operator to obtain a formal approval by Aviation Authority having jurisdiction on the aircraft, for any adaptation necessary before incorporation of the present Service Bulletin.

G. MANPOWER

To comply with this Service Bulletin fifty (50) MMH are deemed necessary.

MMH are based on hands-on time and can change with personnel and facilities available.

H. WEIGHT AND BALANCE

WEIGHT (Kg)	ARM (mm)	MOMENT (Kgmm)
LONGITUDINAL BALANCE	2009	-20090
LATERAL BALANCE	0	0

I. REFERENCES

1) PUBLICATIONS

Following Data Modules refer to AMP:

<u>DATA MODULE</u>	<u>DESCRIPTION</u>	<u>PART</u>
DM01 39-A-00-20-00-00A-120A-A	Helicopter on ground for a safe maintenance.	-
DM02 39-A-06-41-00-00A-010A-A	Access doors and panels - General data	-
DM03 39-A-30-72-01-00A-520A-K	Left windshield - Remove procedure	-
DM04 39-A-30-72-02-00A-520A-K	Right windshield - Remove procedure	-
DM05 39-A-46-20-00-00A-750A-A	Processing and integrating - Options and setting file - Load software procedure	-
DM06 39-A-56-11-01-00A-520A-A	Left windshield - Remove procedure	-
DM07 39-A-56-11-02-00A-520A-A	Right windshield - Remove procedure	-
DM08 39-C-56-13-01-00A-720A-K	Left acrylic windshield - Install procedure	-
DM09 39-C-56-13-02-00A-720A-K	Right acrylic windshield - Install procedure	-

2) ACRONYMS & ABBREVIATIONS

AMDI	Aircraft Material Data Information
AMP	Aircraft Maintenance Publication
DM	Data Module
DOA	Design Organization Approval
EASA	European Aviation Safety Agency
LHD	Leonardo Helicopters Division
MMH	Maintenance Man Hours

P/N Part Number
S/N Serial Number

3) ANNEX

N.A

J. PUBLICATIONS AFFECTED

N.A.

K. SOFTWARE ACCOMPLISHMENT SUMMARY

Software to be updated:

Option file P/N DM60004869-XXXXX.

Option File P/N is depending upon helicopter configuration that can be different from the one reported in relevant helicopter "Commessa di Vendita". Customer must contact Product Support Engineering (engineering.support.lhd@leonardo.com) to request the correct Option File at least three months in advance from the scheduled embodiment of this Service Bulletin.

2. MATERIAL INFORMATION

A. REQUIRED MATERIALS

1) PARTS

#	P/N	ALTERNATIVE P/N	DESCRIPTION	Q.TY	LVL	NOTE	LOG P/N
1	3G5610F00211		KIT ACRYLIC WINDSHIELDS	REF	.		
2	3G5610V00551		Acrylic Transparents LH	1	..		139-695L1
3	3G5610V00651		Acrylic Transparents RH	1	..		139-695L1
4	AN525-10R12		Screw	32	..		139-695L1
5	AN525-10R14		Screw	74	..		139-695L1
6	AW001YC01RED		Lock Ring	8	.	(1)	-
7	NAS813-10		Plug	2	.	(1)	-
8	NAS813-20		Plug	3	.	(1)	-
9	DM60004869-XXXXX		Option File	1	.	(1) (2)	-
10	MS27039C1-18		Screw	AR	.	(5)	-

Refer also to IPD for the spares materials required to comply with the AMP DMs referenced in the accomplishment instructions.

2) CONSUMABLES

The following consumable materials, or equivalent, are necessary to accomplish this Service Bulletin:

#	SPEC./LHD CODE NUMBER	DESCRIPTION	Q.TY	NOTE	PART
11	A582A19 EN6049-006-19-5	Nomex	AR	(1)(3)	-
12	A582A40 EN6049-006-40-5	Nomex	AR	(1)(3)	-
13	AW005ME01T204212	Tape	AR	(1)(4)	-
14	AW005ME05W050805	Washer Sealing	AR		-
15	MC780 B-2 type I spec AWMS05-001 pn 99999999000015244 or 99999999000005967	Sealant	AR	(3)	-

Refer also to AMDI for the consumable materials required to comply with the AMP DM referenced in the accomplishment instructions.

3) LOGISTIC MATRIX

In order to apply this Service Bulletin, the following Logistic P/N can be ordered in accordance with the applicable notes:

LOGISTIC P/N	Q.TY (PER HELO)	NOTE	PART
139-695L1	1	-	-
DM60004869-XXXXX	1	(1) (2)	-

NOTE

- (1) Item to be supplied only for helicopters equipped with kit IPS windshield installation P/N 4G3040A00411.

- (2) Option File P/N is depending upon helicopter configuration that can be different from the one reported in relevant helicopter “Commissa di Vendita” Customers must contact Product Support Engineering (engineering.support.lhd@leonardo.com) to request the correct Option File at least three months in advance from the scheduled application of this Service Bulletin.
- (3) Item to be procured as local supply.
- (4) Alternative item that can be ordered is lacing cord P/N AW001CK03LC (quantity AR).
- (5) Item to be ordered only if kit Wire Strike Protection Long Nose P/N 4G9540F00212 has been installed on the helo.

B. SPECIAL TOOLS

Refer to ITEP for the special tools required to comply with the AMP DM referenced in the accomplishment instructions.

C. INDUSTRY SUPPORT INFORMATION

Configuration change.

3. ACCOMPLISHMENT INSTRUCTIONS

GENERAL NOTES

- a) Place an identification tag on all components that are re-usable, including the attaching hardware that has been removed to gain access to the modification area and adequately protect them until their later re-use.
 - b) Shape the cables in order to prevent interference with the structure and the other existing installations, using where necessary suitable lacing cords and plastic cable tiedown.
 - c) Exercise extreme care during drilling operations to prevent instruments, cables and hoses damage.
 - d) After drilling, remove all swarf and sharp edges. Apply on bare metal a light film of primer unless the hole is used for ground connection.
 - e) During the installation of bonding braids or components requiring grounding, clean the surface structure in order to obtain a good ground contact.
 - f) Let adhesive cure at room temperature for at least 24 hours unless otherwise specified.
 - g) Exposed thread surface and nut must be protected using a layer of tectyl according to MIL-C-16173 grade I.
 - h) All lengths are in mm.
-
1. In accordance with AMP DM 39-A-00-20-00-00A-120A-A, prepare the helicopter on ground for a safe maintenance. Disconnect the battery, all electrical power sources and/or the external power supply.
 2. In accordance with AMP DM 39-A-06-41-00-00A-010A-A and with reference to Figure 1, 2, 6 and 8, remove all external panels, internal panels and internal liners as required to gain access to the area affected by the installations.

NOTE

Following steps 3 thru 11 are applicable ONLY to helicopters equipped with kit IPS windshield installation P/N 4G3040A00411.

3. In accordance with AMP DM 39-A-30-72-01-00A-520A-K and with reference to Figure 1, remove the left windshield P/N 4G5610V00131 and the related hardware. Retain washers for later re-use.
4. With reference to Figure 3, protect the sectioning connector J175 by means of the plug P/N NAS813-20.
5. In accordance with AMP DM 39-A-30-72-02-00A-520A-K and with reference to Figure 1, remove the right windshield P/N 4G5610V00231 and the related hardware. Retain washers for later re-use.
6. With reference to Figure 3, protect the sectioning connector J176 by means of the plug P/N NAS813-20.
7. With reference to Figure 4 View B and Detail D, disconnect connector A234P1 and protect by means of the plug P/N NAS813-20, the nomex P/N A582A40 or P/N EN6049-006-40-5 and the tape P/N 900004953.
8. With reference to Figure 5 View C and Detail E, disconnect connector MT14 and protect by means of the plug P/N NAS813-10, the nomex P/N A582A19 or P/N EN6049-006-19-5 and the tape P/N 900004953.
9. With reference to Figure 5 View C and Detail E, disconnect connector MT15 and protect by means of the plug P/N NAS813-10, the nomex P/N A582A19 or P/N EN6049-006-19-5 and the tape P/N 900004953.
10. With reference to Figures 6 and 7, install n°7 lock rings P/N AW001YC01RED on the breaker of the integrally light util breaker panel P/N 3G2490L02151.

NOTE

Option File P/N is depending upon helicopter configuration that can be different from the one reported in relevant helicopter "Commissa di Vendita". Customer must contact AW139 Product Support Engineering (engineering.support.lhd@leonardo.com) to request the correct Option File at least three months in advance from the scheduled embodiment of this Service Bulletin.

11. In accordance with AMP DM 39-A-46-20-00-00A-750A-A, ensure that the applicable version of Option file has been installed.

NOTE

Following steps 12 and 13 are applicable ONLY to helicopters NOT equipped with kit IPS windshield installation P/N 4G3040A00411.

12. In accordance with AMP DM 39-A-56-11-01-00A-520A-A and with reference to Figure 8, remove the left windshield P/N 3G5610A00534 and the related hardware. Retain washers for later re-use.
13. In accordance with AMP DM 39-A-56-11-02-00A-520A-A and with reference to Figure 8, remove the right windshield P/N 3G5610A00434 and the related hardware. Retain washers for later re-use.

CAUTION

BEFORE PERFORMING STEP 14 AND STEP 15 MAKE SURE THAT THE GASKET TAPE IS NOT DAMAGED AND FULLY BONDED ALONG THE EDGE AREA OF THE ACRYLIC TRANSPARENT LH/RH.

NOTE

While performing step 14 and step 15 if necessary, it is permitted to increase the diameter of the transparent attach holes to a maximum of 5.90÷6.01 mm.

14. In accordance with AMP DM 39-C-56-13-01-00A-720A-K and with reference to Figures 8 thru 10, install the acrylic transparent LH P/N 3G5610V00551
15. In accordance with AMP DM 39-C-56-13-02-00A-720A-K and with reference to Figures 8 thru 10, install acrylic transparent RH P/N 3G5610V00651.
16. In accordance with AMP DM 39-A-06-41-00-00A-010A-A, re-install all external panels, internal panels and internal liners previously removed as required.
17. In accordance with weight and balance changes, update the Chart A (see Rotorcraft Flight Manual, Part II, section 6).
18. Return the helicopter to flight configuration and record for compliance with this Service Bulletin on the helicopter logbook.
19. Send the attached compliance form to the following mail box:

engineering.support.lhd@leonardo.com

As an alternative, gain access to My Communications section on Leonardo WebPortal and compile the "Service Bulletin Application Communication".

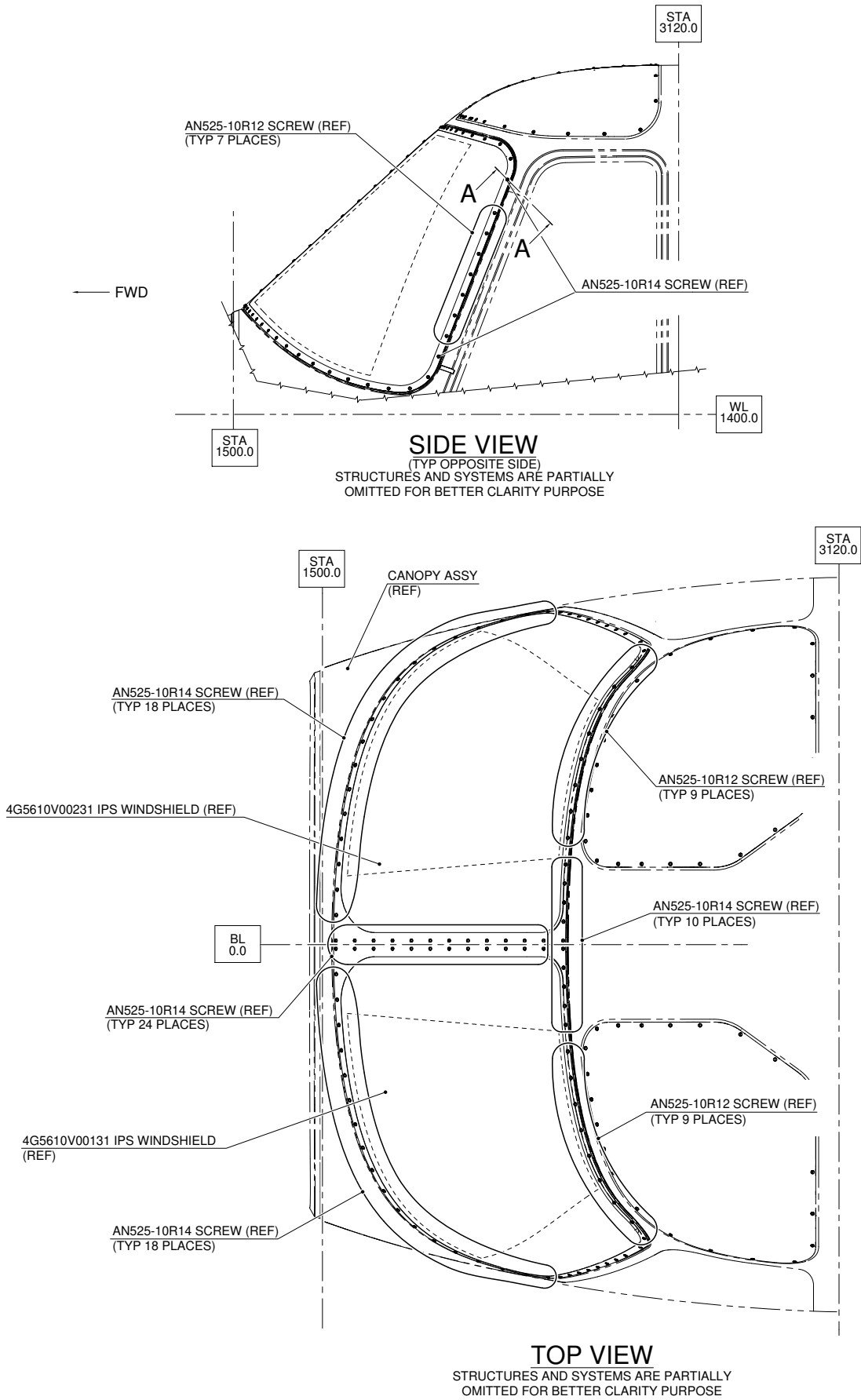

Figure 1

S.B. N°139-695
 DATE: June 9, 2022
 REVISION: /

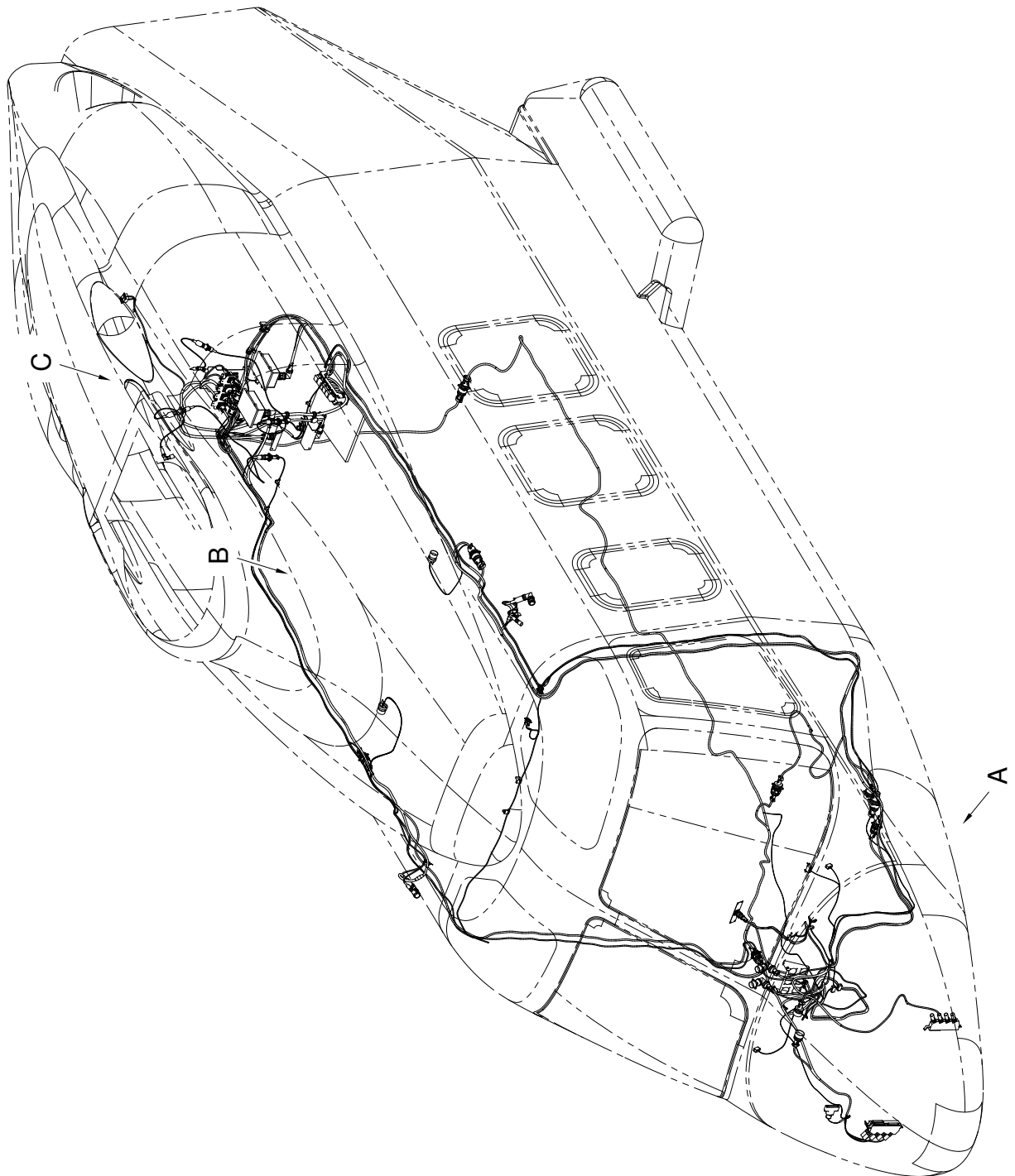

Figure 2

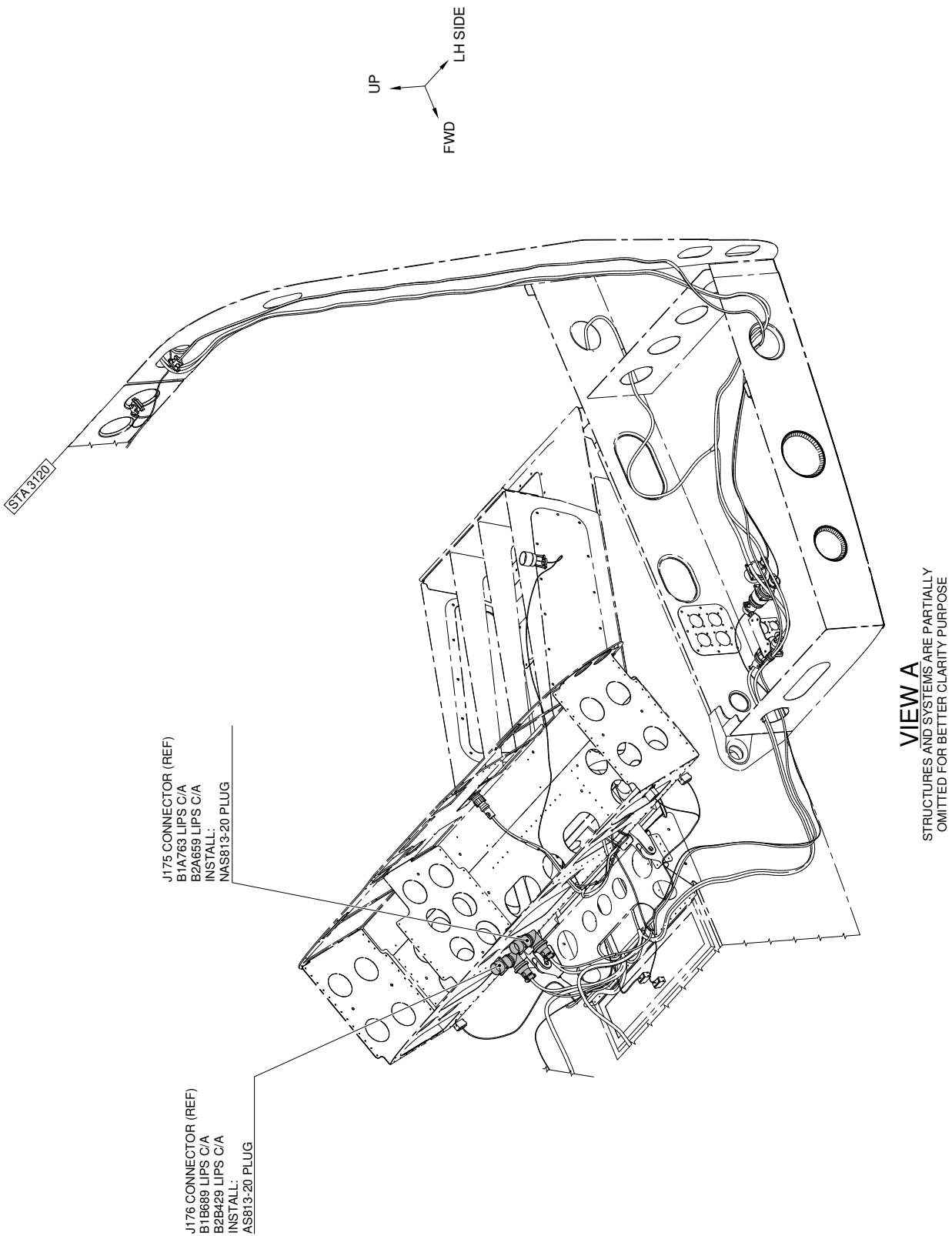

Figure 3

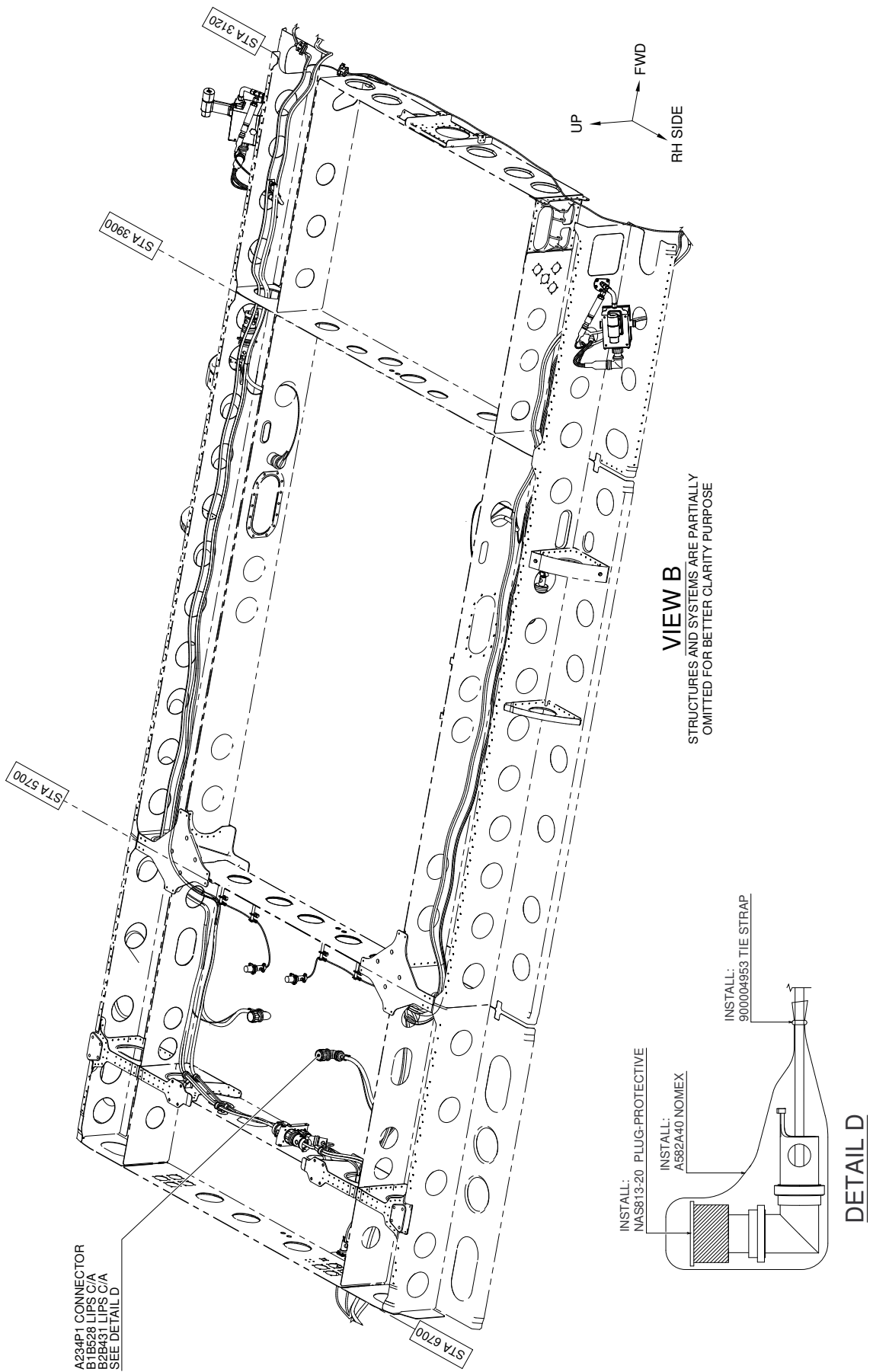

Figure 4

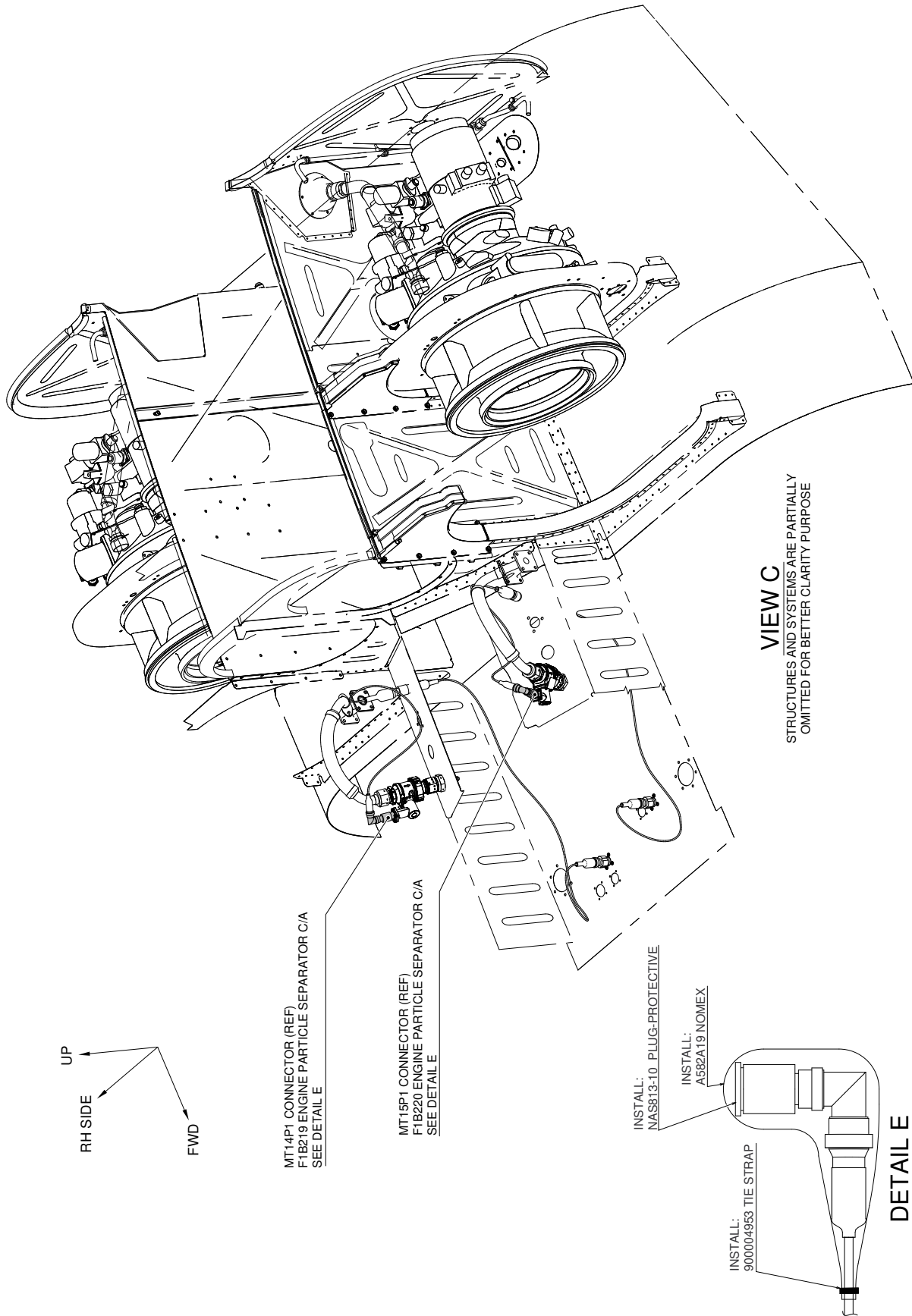
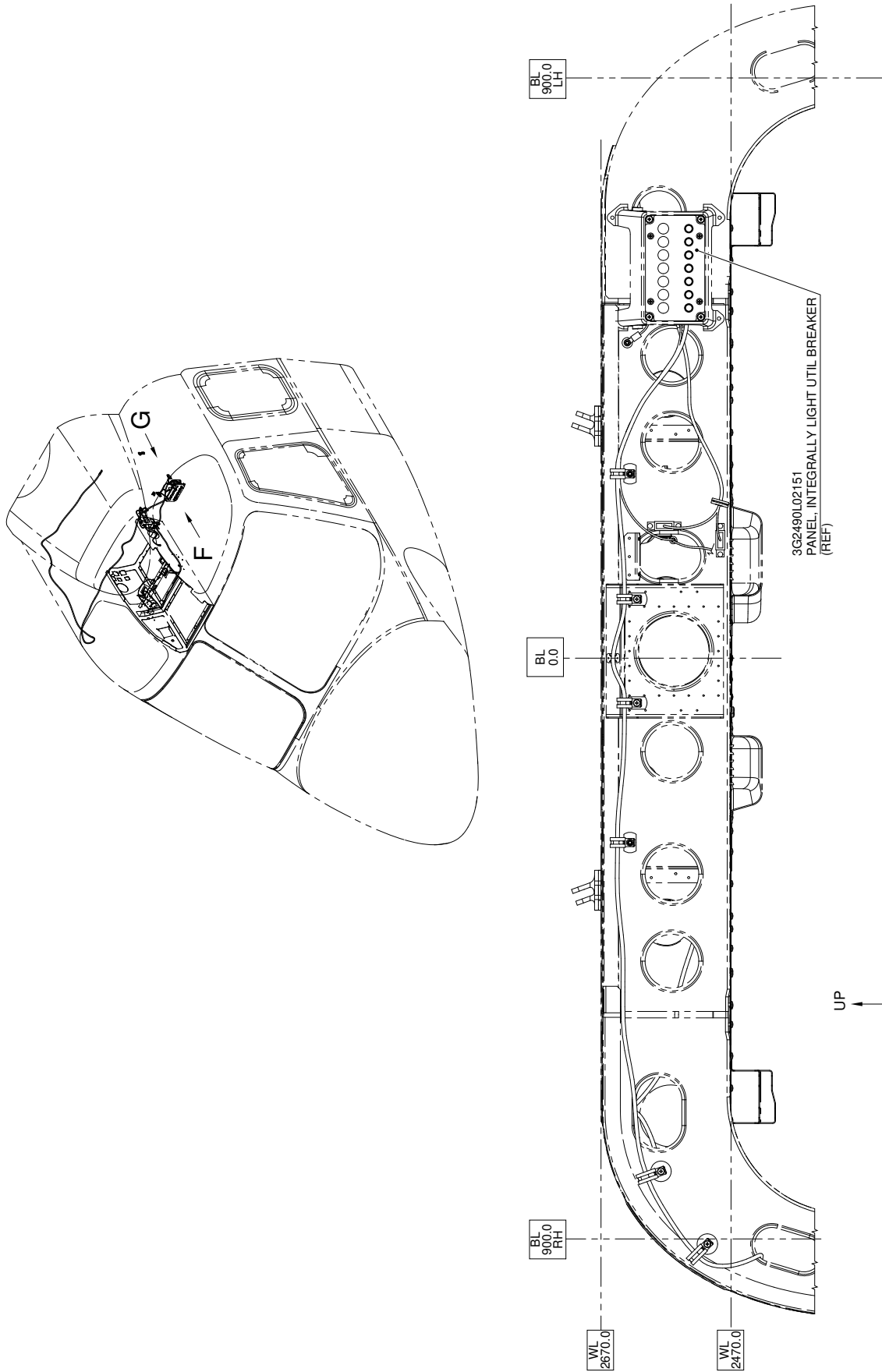
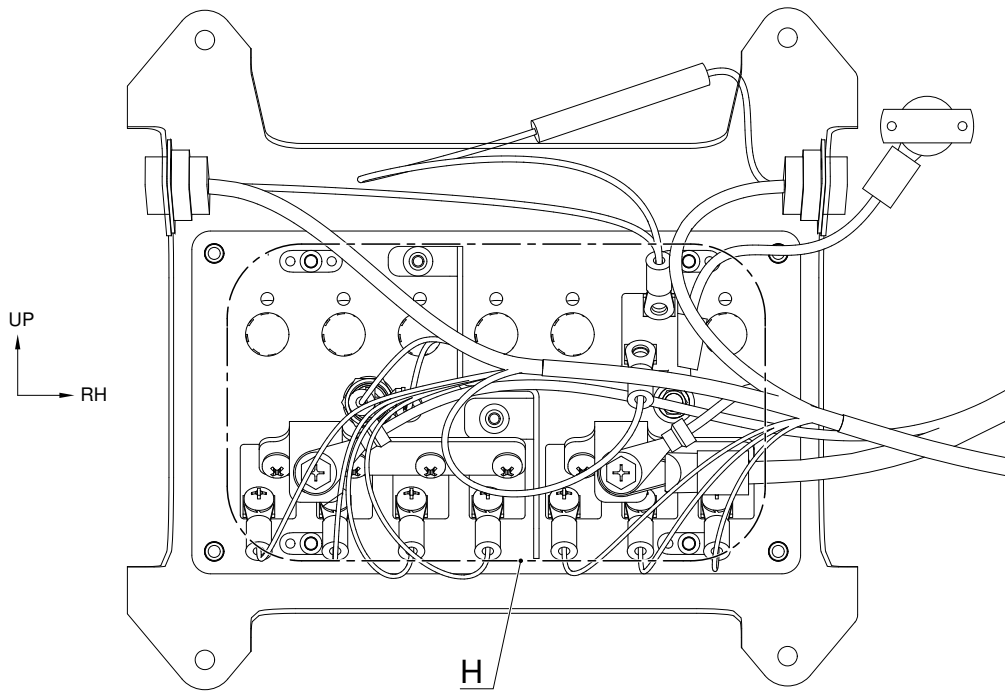

Figure 5



VIEW F
STRUCTURES AND SYSTEMS ARE PARTIALLY
OMITTED FOR BETTER CLARITY PURPOSE

Figure 6



VIEW G

STRUCTURES AND SYSTEMS ARE PARTIALLY OMITTED FOR BETTER CLARITY PURPOSE

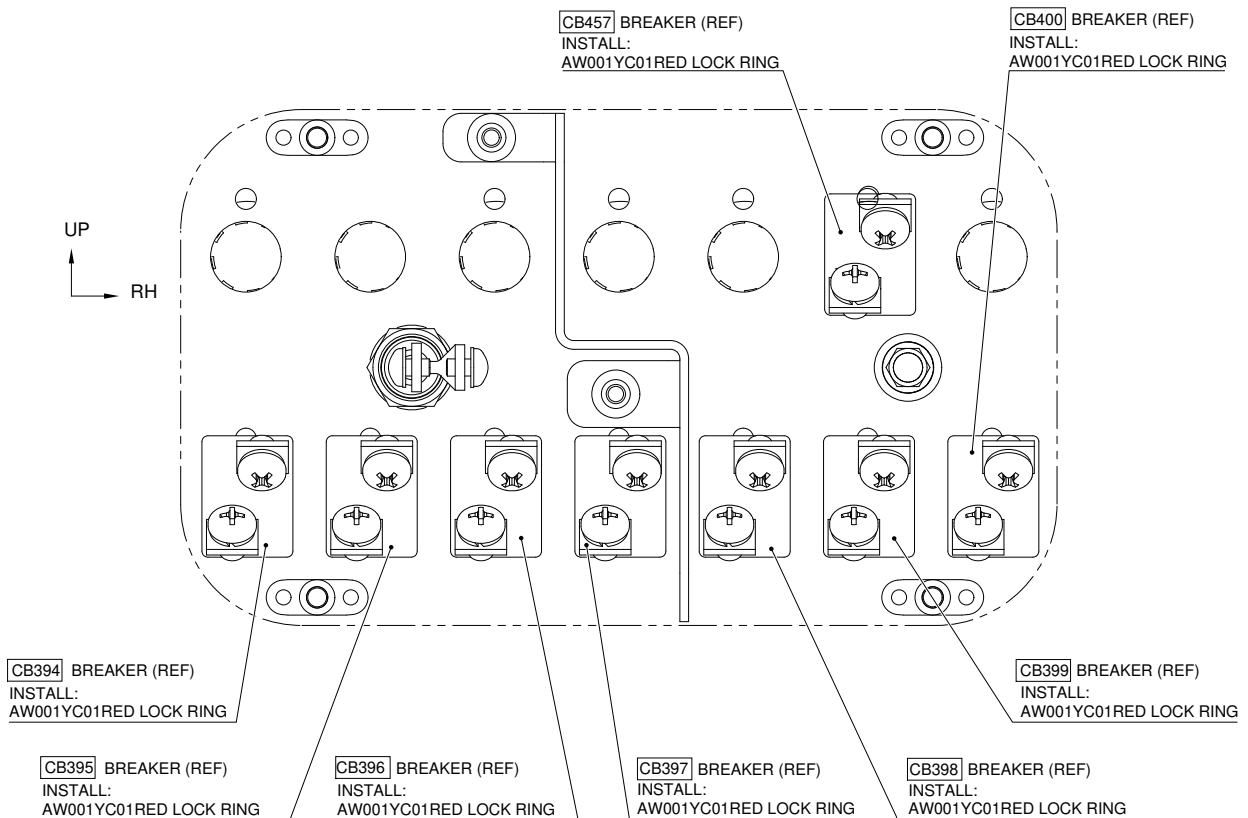

DETAIL H

STRUCTURES AND SYSTEMS ARE PARTIALLY OMITTED FOR BETTER CLARITY PURPOSE

Figure 7

3G5610F00211
KIT ACRYLIC WINDSHIELDS

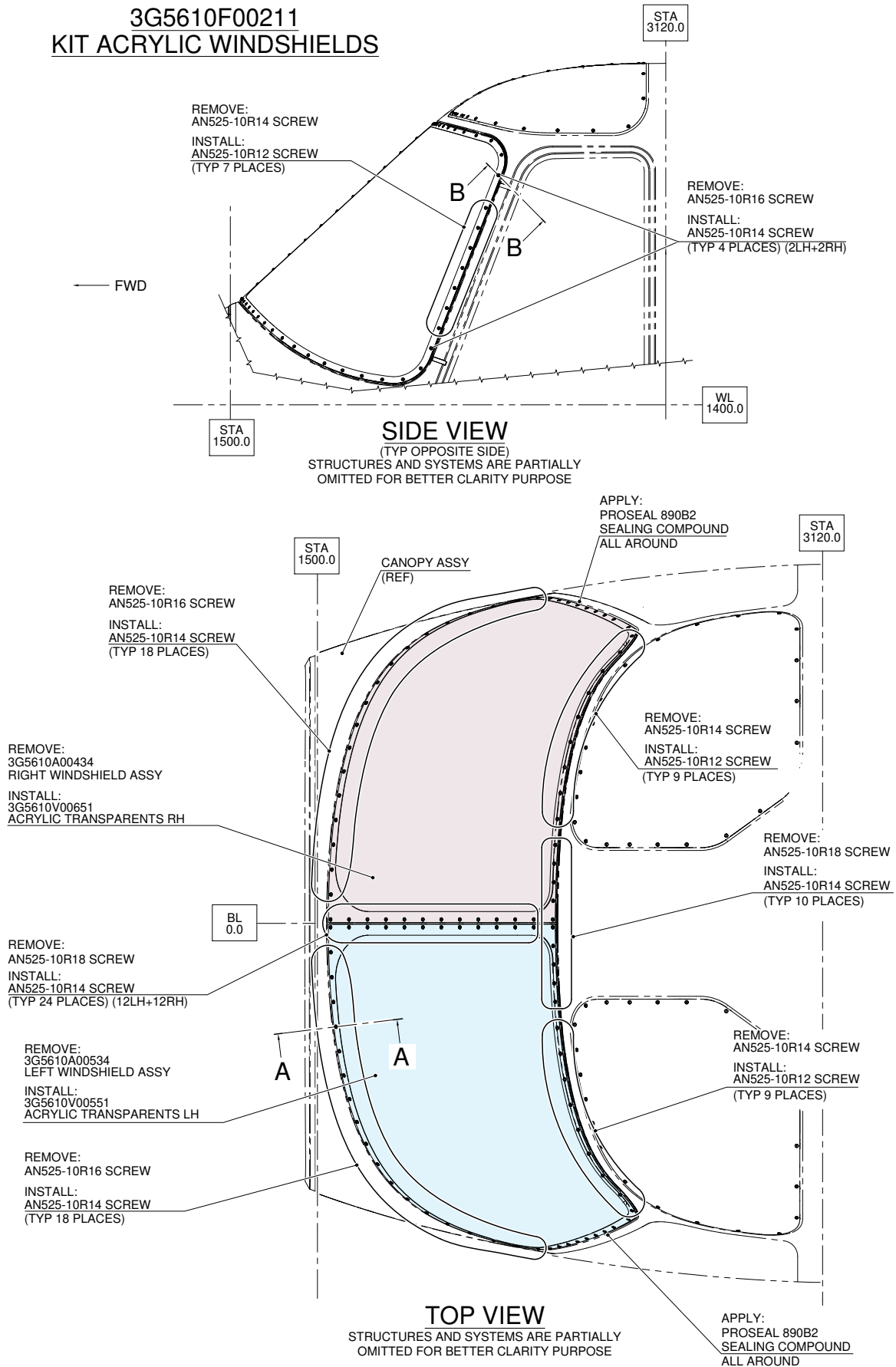
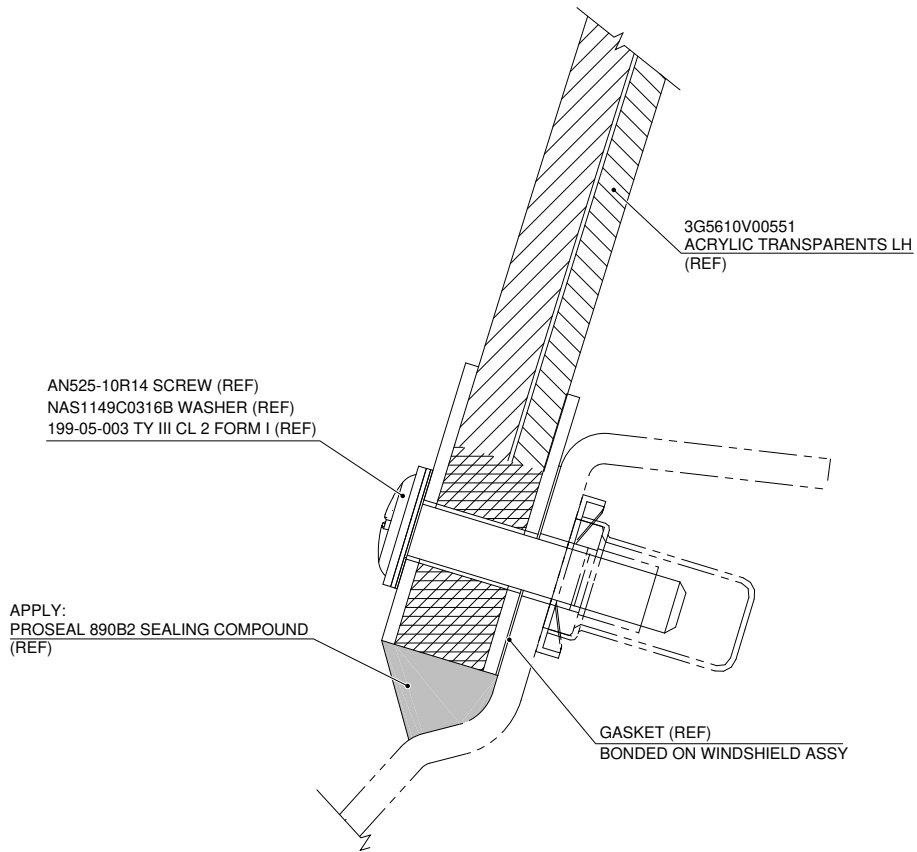
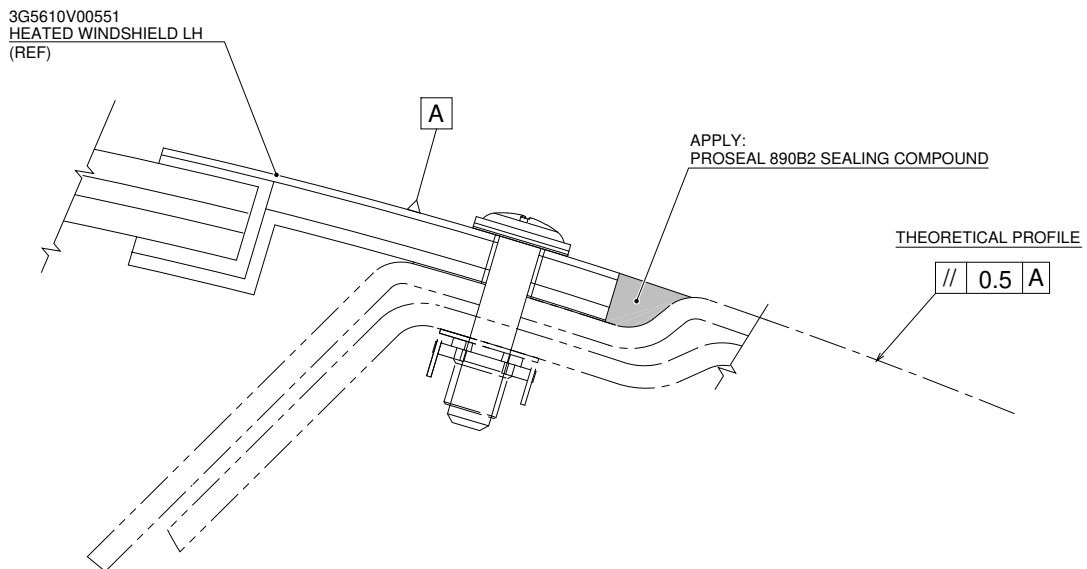

Figure 8



SECTION A-A

STRUCTURES AND SYSTEMS ARE PARTIALLY
OMITTED FOR BETTER CLARITY PURPOSE



SECTION B-B

STRUCTURES AND SYSTEMS ARE PARTIALLY
OMITTED FOR BETTER CLARITY PURPOSE

Figure 9

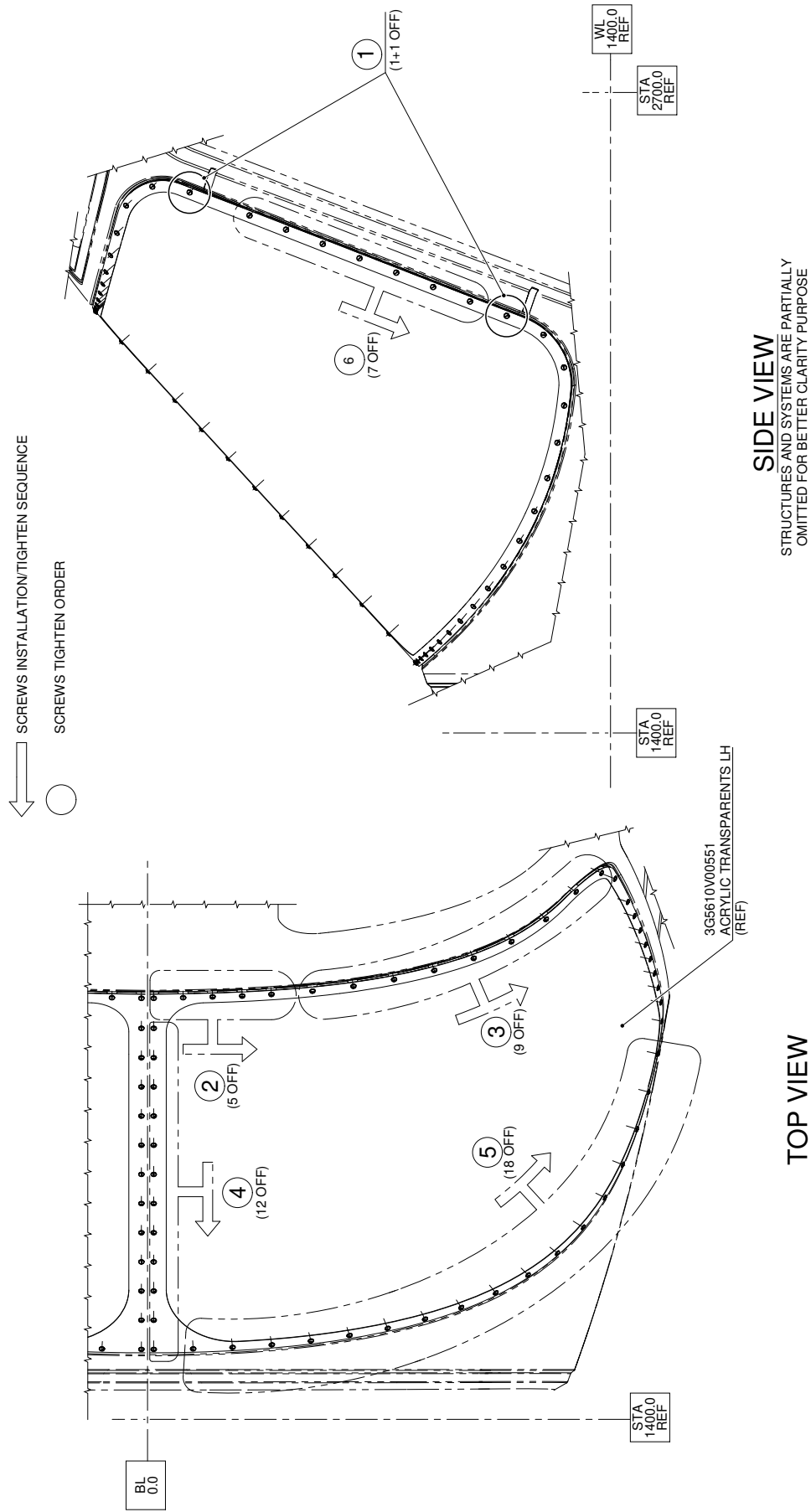

Figure 10

Please send to the following address: LEONARDO S.p.A. CUSTOMER SUPPORT & SERVICES - ITALY PRODUCT SUPPORT ENGINEERING & LICENSES DEPT. Via Giovanni Agusta, 520 21017 Cascina Costa di Samarate (VA) - ITALY Tel.: +39 0331 225036 Fax: +39 0331 225988		SERVICE BULLETIN COMPLIANCE FORM		Date:	
		Number:			
		Revision:			
Customer Name and Address:			Telephone:		
			Fax:		
			B.T. Compliance Date:		
Helicopter Model	S/N	Total Number	Total Hours	T.S.O.	
Remarks:					
Information: We request your cooperation in filling this form, in order to keep out statistical data relevant to aircraft configuration up-to-date. The form should be filled in all its parts and sent to the above address or you can communicate the application also via Technical Bulletin Application Communication Section placed in Leonardo AW Customer Portal - MyCommunications Area. We thank you beforehand for the information given.					