SERVICE BULLETIN

N° **139-684**

DATE: November 10, 2021

REV. : A - February 21, 2023

TITLE

ATA 93 - TURRET FLIR UNIT REPLACEMENT

REVISION LOG

Rev. A is issued in order to update the accomplishment instruction to introduce the possibility to mark the TFU in accordance to drawing P/N 3G9350I02031.

Revision bars identify changes.

1. PLANNING INFORMATION

A. EFFECTIVITY

AW139 helicopters from S/N 41801 to S/N 41806.

B. COMPLIANCE

At Customer's option.

C. CONCURRENT REQUIREMENTS

N.A.

D. REASON

This Service Bulletin is issued in order to provide the necessary instruction on how to perform the replacement of the Turret FLIR Unit.

LH issued this SB for the following reason:

Helicopter Reliability/Maintainability	
Product Improvement	
Obsolescence	
Customization	
Product/Capability Enhancement	✓

E. DESCRIPTION

This Service Bulletin gives instruction to replace the FLIR SS380 HDc TFU P/N 3G9350I01231 with the FLIR SS380 HDc TFU P/N 3G9350I02031.

F. APPROVAL

The technical content of this Service Bulletin is approved under the authority of DOA nr. EASA.21.J.005. For helicopters registered under other Aviation Authorities, before applying the Service Bulletin, applicable Aviation Authority approval must be checked within Leonardo Helicopters customer portal.

EASA states mandatory compliance with inspections, modifications or technical directives and related time of compliance by means of relevant Airworthiness Directives. If an aircraft listed in the effectivity embodies a modification or repair not LHD certified and affecting the content of this Service Bulletin, it is responsibility of the Owner/Operator to obtain a formal approval by Aviation Authority having jurisdiction on

S.B. N°139-684

DATE: November 10, 2021

REVISION:A - February 21, 2023

the aircraft, for any adaptation necessary before incorporation of the present Service Bulletin.

G. MANPOWER

To comply with this Service Bulletin twenty-four (24) MMH are deemed necessary. MMH are based on hands-on time and can change with personnel and facilities available.

H. WEIGHT AND BALANCE

N.A.

I. REFERENCES

1) PUBLICATIONS

Following Data Modules refer to AMP:

<u>DATA MODULE</u>	<u>DESCRIPTION</u>	<u>PART</u>
DM01 39-A-00-20-00-00A-120A-A	Helicopter on ground for a safe maintenance	-
DM02 39-B-93-55-00-00A-320A-K	Thermal imaging system - Operation test	-

Following Data Modules refer to CSPP:

<u>DATA MODULE</u>	<u>DESCRIPTION</u>	<u>PART</u>
DM03 CSPP-A-60-80-03-00A-691A-C	Aircraft Parts - Marking	-

2) ACRONYMS & ABBREVIATIONS

AMDI	Aircraft Material Data Information
AMP	Aircraft Maintenance Publication
DM	Data Module
DOA	Design Organization Approval
EASA	European Aviation Safety Agency
FLIR	Forward Looking Infra-Red
HD	High Definition
IPD	Illustrated Parts Data
ITEP	Illustrated Tool and Equipment Publication
LH	Leonardo Helicopters
MMH	Maintenance Man Hours
N.A.	Not applicable
P/N	Part Number

S/N Serial Number
TFU Turret FLIR Unit

3) ANNEX

N.A.

J. PUBLICATIONS AFFECTED

N.A.

K. SOFTWARE ACCOMPLISHMENT SUMMARY

N.A.

2. MATERIAL INFORMATION

A. REQUIRED MATERIALS

1) PARTS

#	P/N	ALTERNATIVE P/N	DESCRIPTION	Q.TY	LVL	NOTE	LOG P/N
1	3G9350I02031		FLIR SS380 HDc TFU vendor control drawing	1	.	(1)	-

Refer also to IPD for the spares materials required to comply with the AMP DMs referenced in the accomplishment instructions.

2) CONSUMABLES

Refer also to AMDI for the consumable materials required to comply with the AMP DM referenced in the accomplishment instructions.

3) LOGISTIC MATRIX

N.A.

NOTE

(1) The P/N 3G9350I02031 might be also supplied as the TFU P/N 3290008-317 and the plate P/N A016A004B1.

B. SPECIAL TOOLS

Refer also to ITEP for the special tools required to comply with the AMP DM referenced in the accomplishment instructions.

C. INDUSTRY SUPPORT INFORMATION

Configuration change.

3. ACCOMPLISHMENT INSTRUCTIONS

GENERAL NOTES

- a) Place an identification tag on all components that are re-usable, including the attaching hardware that has been removed to gain access to the modification area and adequately protect them until their later re-use.
- b) Shape the cables in order to prevent interference with the structure and the other existing installations, using where necessary suitable lacing cords and plastic cable tiedown.

1. In accordance with AMP DM 39-A-00-20-00-00A-120A-A, prepare the helicopter on ground for a safe maintenance. Disconnect the battery, all electrical power sources and/or the external power supply.
2. With reference to Figure 1, gain access to the area affected by the installation and perform the TFU replacement as described in the following procedure:
 - 2.1 With reference to Figure 1, disconnect the connectors and remove the FLIR SS380 HDc TFU vendor control drawing P/N 3G9350I01231 from the helicopter. Retain hardware for later reuse.

NOTE

Perform the following steps 2.2 and 2.3 only if the FLIR TFU P/N 3G9350I02031 is supplied as the TFU P/N 3290008-317 and the plate P/N A016A004B1.

- 2.2 With reference to Figure 2, check the installation of vendor identification label.
- 2.3 After the inspection, apply label P/N A016A004B1 and, in accordance with CSPP DM CSPP-A-60-80-03-00A-691A-C, mark P/N 3G9350I02031 on it.
- 2.4 With reference to Figure 1, carefully lift the FLIR SS380 HDc TFU vendor control drawing P/N 3G9350I02031 until it is against the quick plate on its housing.
- 2.5 With reference to Figure 1, attach the FLIR SS380 HDc TFU vendor control drawing P/N 3G9350I02031 to the quick plate by means of existing hardware previously removed. Connect the connectors to the FLIR SS380 HDc TFU vendor control drawing.
3. In accordance with the applicable steps of AMP DM 39-B-93-55-00-00A-320A-K, perform the operations test of the FLIR STAR SAFIRE 380 HDc.
4. Return the helicopter to flight configuration and record for compliance with this Service

S.B. N°139-684

DATE: November 10, 2021

REVISION:A - February 21, 2023

Bulletin on the helicopter logbook.

5. Send the attached compliance form to the following mail box:

engineering.support.lhd@leonardocompany.com

As an alternative, gain access to My Communications section on Leonardo WebPortal and compile the "Service Bulletin Application Communication".

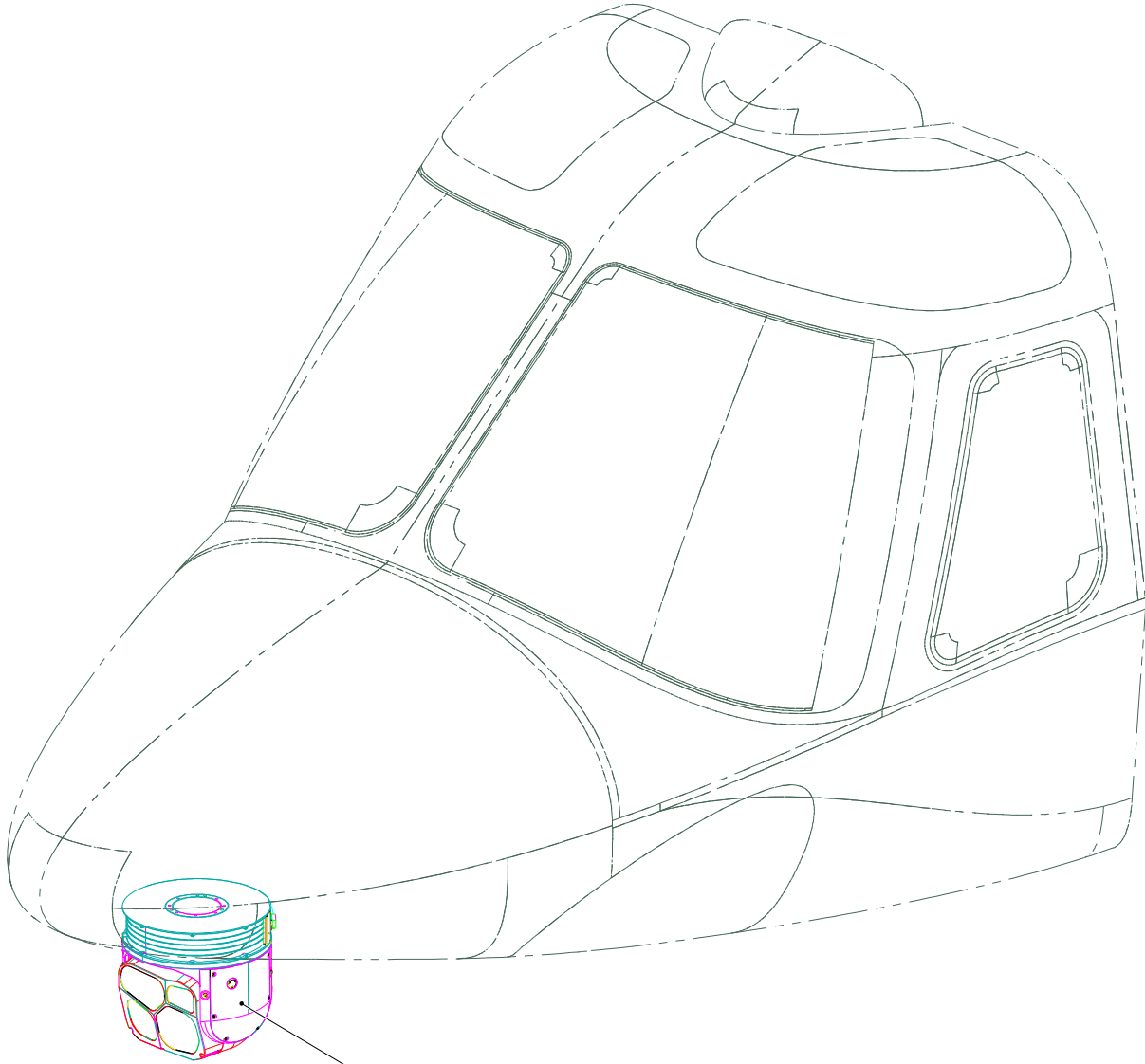

REMOVE:
3G9350101231 FLIR SS380 HDC TFU VENDOR CONTROL DRAWING
INSTALL:
3G9350102031 FLIR SS380 HDC TFU VENDOR CONTROL DRAWING
(USE EXISTING HARDWARE)

Figure 1

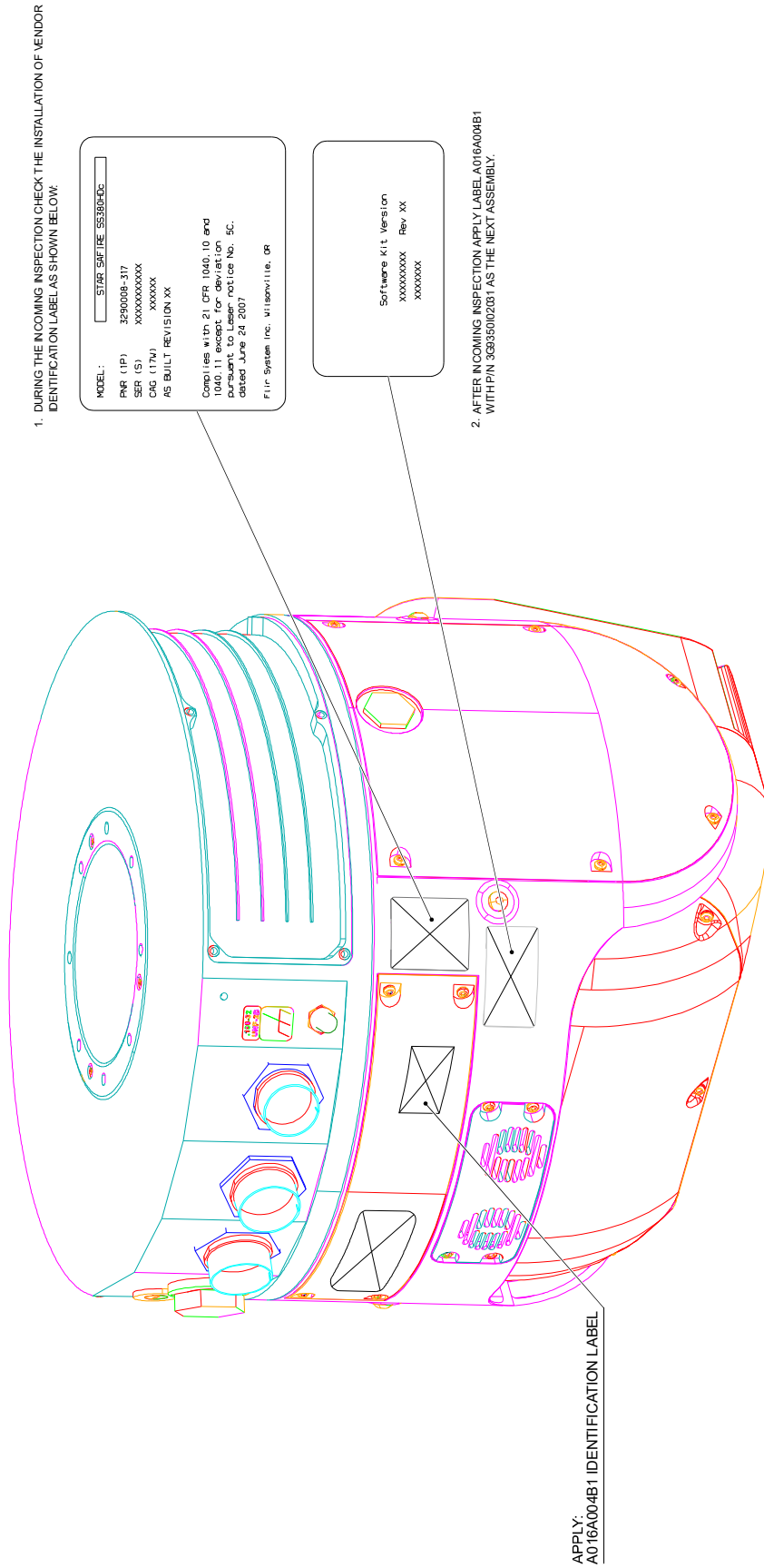

Figure 2

