

---

---

**SERVICE BULLETIN**

**N° 139-683**

**DATE:** February 22, 2023

**REV. :** /

---

---

**TITLE**

**ATA 52 - COCKPIT DOOR POCKET LH INSTALLATION**

**REVISION LOG**

First Issue

---

An appropriate entry should be made in the aircraft log book upon accomplishment.  
If ownership of aircraft has changed, please, forward to new owner.

---

## **1. PLANNING INFORMATION**

### **A. EFFECTIVITY**

All AW139 helicopters equipped with high visibility doors and NOT equipped with HEELS.

### **B. COMPLIANCE**

At Customer's option.

### **C. CONCURRENT REQUIREMENTS**

N.A.

### **D. REASON**

This Service Bulletin provides the necessary instruction to install the Cockpit Door Pocket LH Installation Kit P/N 4G2580F00511.

### **E. DESCRIPTION**

The Cockpit Door Pocket LH Kit introduces a pocket on the copilot door (LH side) that provides additional storage space in the cockpit area. The kit is compatible with high visibility doors NOT equipped with HEELS.

### **F. APPROVAL**

The technical content of this Service Bulletin is approved under the authority of DOA nr. EASA.21.J.005. For helicopters registered under other Aviation Authorities, before applying the Service Bulletin, applicable Aviation Authority approval must be checked within Leonardo Helicopters customer portal.

EASA states mandatory compliance with inspections, modifications or technical directives and related time of compliance by means of relevant Airworthiness Directives. If an aircraft listed in the effectivity embodies a modification or repair not LHD certified and affecting the content of this Service Bulletin, it is responsibility of the Owner/Operator to obtain a formal approval by Aviation Authority having jurisdiction on the aircraft, for any adaptation necessary before incorporation of the present Service Bulletin.

### **G. MANPOWER**

To comply with this Service Bulletin eight (8) MMH are deemed necessary.

MMH are based on hands-on time and can change with personnel and facilities available.

## H. WEIGHT AND BALANCE

WEIGHT (Kg)	ARM (mm)	MOMENT (Kgmm)
		1.43
LONGITUDINAL BALANCE	2642	3778.06
LATERAL BALANCE	0.11	0.16

## I. REFERENCES

### 1) PUBLICATIONS

Following Data Modules refer to AMP:

<u>DATA MODULE</u>	<u>DESCRIPTION</u>	<u>PART</u>
DM01 39-A-00-20-00-00A-120A-A	Helicopter on ground for a safe maintenance.	-

### 2) ACRONYMS & ABBREVIATIONS

AMDI	Aircraft Material Data Information
AMP	Aircraft Maintenance Publication
AR	As Required
DM	Data Module
DOA	Design Organization Approval
EASA	European Aviation Safety Agency
FWD	Forward
HEELS	Helicopter Emergency Egress Lighting System
IPD	Illustrated Part Data
ITEP	Illustrated tool and equipment publication
LH	Left Hand
LHD	Leonardo Helicopters Division
MMH	Maintenance Man Hours
N.A.	Not Applicable
P/N	Part Number
RH	Right Hand
SB	Service Bulletin
S/N	Serial Number

### 3) ANNEX

N.A.

**J. PUBLICATIONS AFFECTED**

AW139 AMP

AW139 IPD

**K. SOFTWARE ACCOMPLISHMENT SUMMARY**

N.A.

## 2. MATERIAL INFORMATION

### A. REQUIRED MATERIALS

#### 1) PARTS

#	P/N	ALTERNATIVE P/N	DESCRIPTION	Q.TY	LVL	NOTE	LOG P/N
1	4G2580F00511		COCKPIT DOOR POCKET LH INSTALLATION KIT	REF	.		-
2	3G2580A87131		Fabric cover assy LH FWD	1	..	(1)	139-683L1
3	3G2580A87231		Fabric cover assy LH rear	1	..	(1)	139-683L1
4	3G2580A87331		Cockpit door pocket assy LH	1	..	(1)	139-683L1
5	A428A3C07		Screw	10	..		139-683L1

Refer also to IPD for the spares materials required to comply with the AMP DMs referenced in the accomplishment instructions.

#### 2) CONSUMABLES

The following consumable materials, or equivalent, are necessary to accomplish this Service Bulletin:

#	SPEC./LHD CODE NUMBER	DESCRIPTION	Q.TY	NOTE	PART
6	Commercial	Adhesive tape 3M 8561 (C048)	AR	(2)	-

Refer also to AMDI for the consumable materials required to comply with the AMP DM referenced in the accomplishment instructions.

#### 3) LOGISTIC MATRIX

In order to apply this Service Bulletin, the following Logistic P/N can be ordered in accordance with the applicable notes:

LOGISTIC P/N	Q.TY (PER HELO)	NOTE	PART
139-683L1	1	-	-

#### NOTE

- (1) This item can be provided as part of P/N 4G2580F00511A1.
- (2) Item to be procured as local supply.

### B. SPECIAL TOOLS

Refer to ITEP for the special tools required to comply with the AMP DM referenced in the accomplishment instructions.

### C. INDUSTRY SUPPORT INFORMATION

Customization.

### **3. ACCOMPLISHMENT INSTRUCTIONS**

#### **GENERAL NOTES**

- a) Place an identification tag on all components that are re-usable, including the attaching hardware that has been removed to gain access to the modification area and adequately protect them until their later re-use.
  - b) Exposed thread surface and nut must be protected using a layer of tectyl according to MIL-C-16173 grade I.
  - c) All lengths are in mm.
- 
1. In accordance with DM 39-A-00-20-00-00A-120A-A, prepare the helicopter on ground for a safe maintenance. Disconnect the battery, all electrical power sources and/or the external power supply.
  2. With reference to Figure 1 View A, remove n°10 screws P/N A428A3C05.
  3. With reference to Figure 2 Detail B, install the adhesive tape 3M 8561 (C048) as shown in the figure on the window glass LH.
  4. With reference to Figure 1 View A, install the cockpit door pocket assy LH P/N 3G2580A87331 by means of n°10 screws P/N A428A3C07.
  5. With reference to Figure 1 View A and Figure 2 Section C-C, install the fabric cover assy LH rear P/N 3G2580A87231.
  6. With reference to Figure 1 View A and Figure 2 Section D-D, install the fabric cover assy LH FWD P/N 3G2580A87131.
  7. Return the helicopter to flight configuration and record for compliance with this Service Bulletin on the helicopter logbook.
  8. Send the attached compliance form to the following mail box:  
[engineering.support.lhd@leonardo.com](mailto:engineering.support.lhd@leonardo.com)  
As an alternative, gain access to My Communications section on Leonardo WebPortal and compile the "Service Bulletin Application Communication".

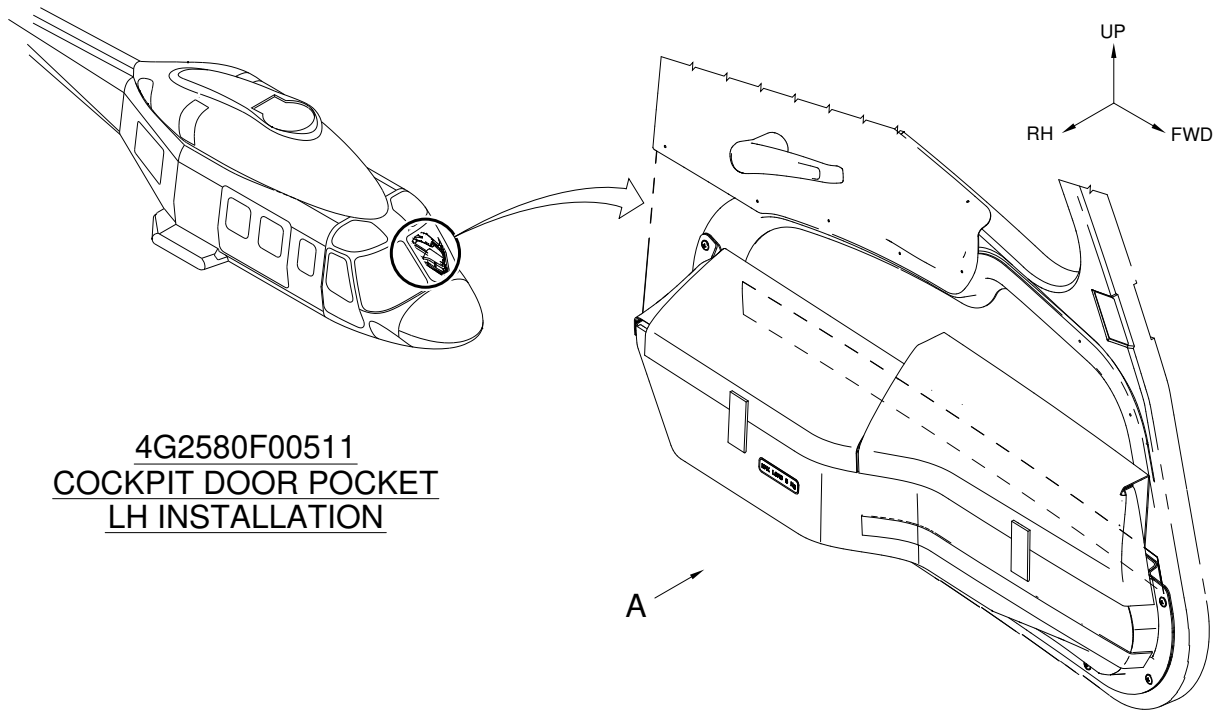

**4G2580F00511  
COCKPIT DOOR POCKET  
LH INSTALLATION**

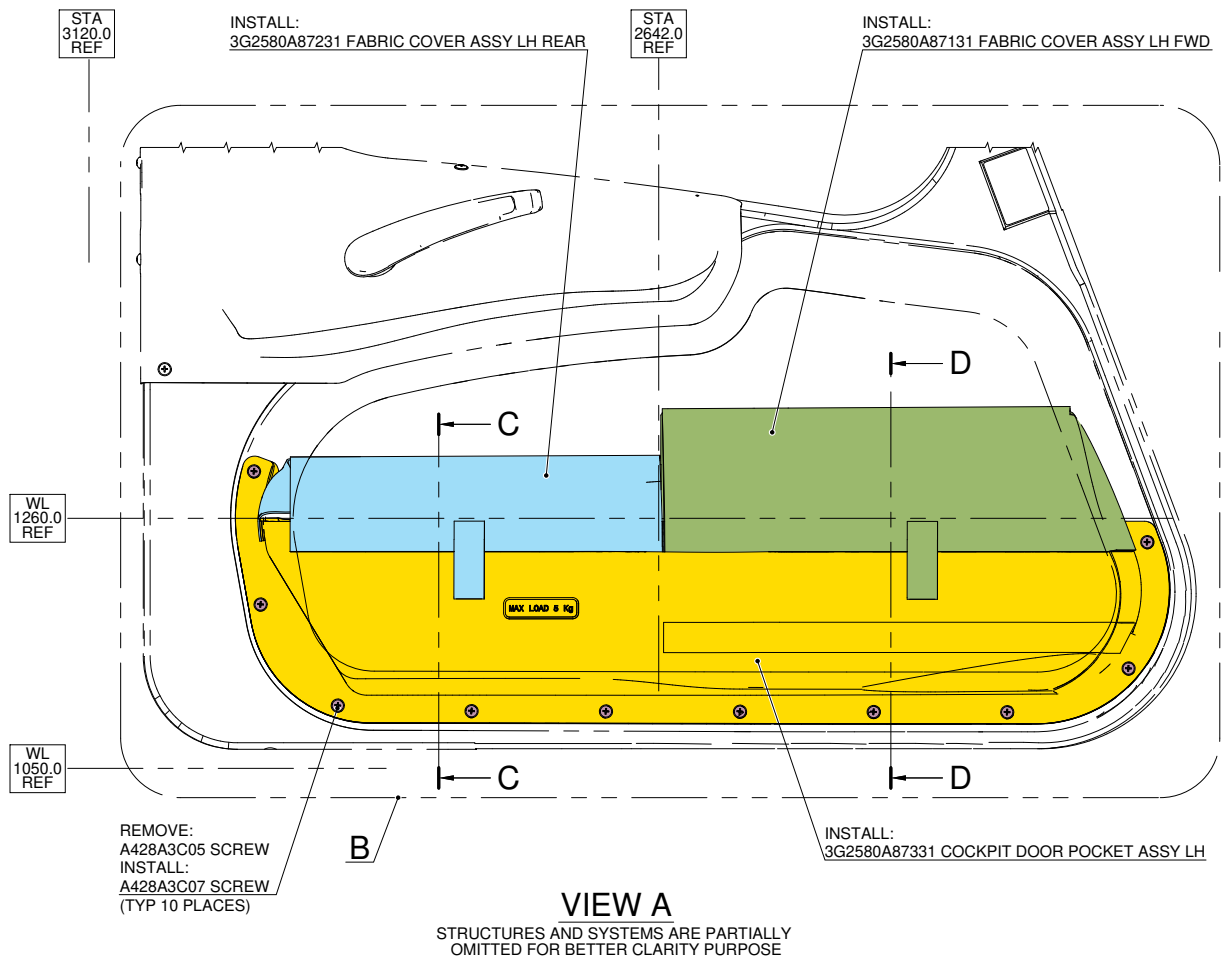

**Figure 1**

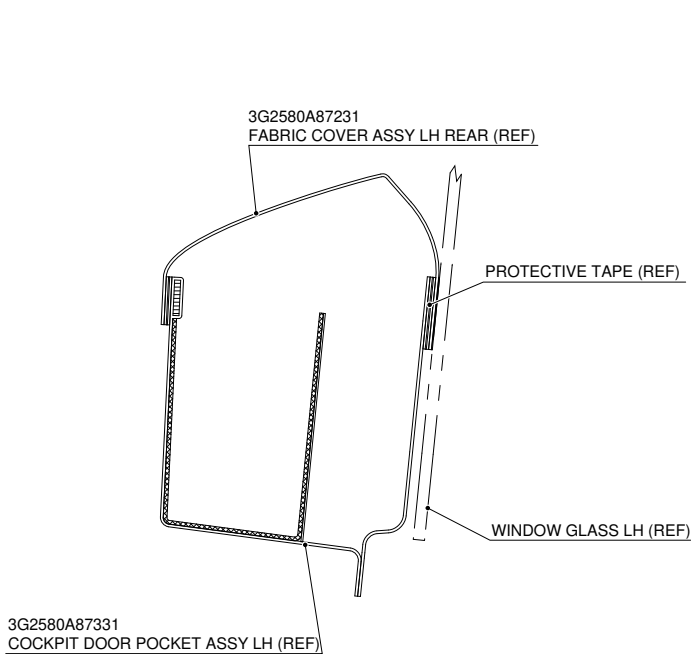
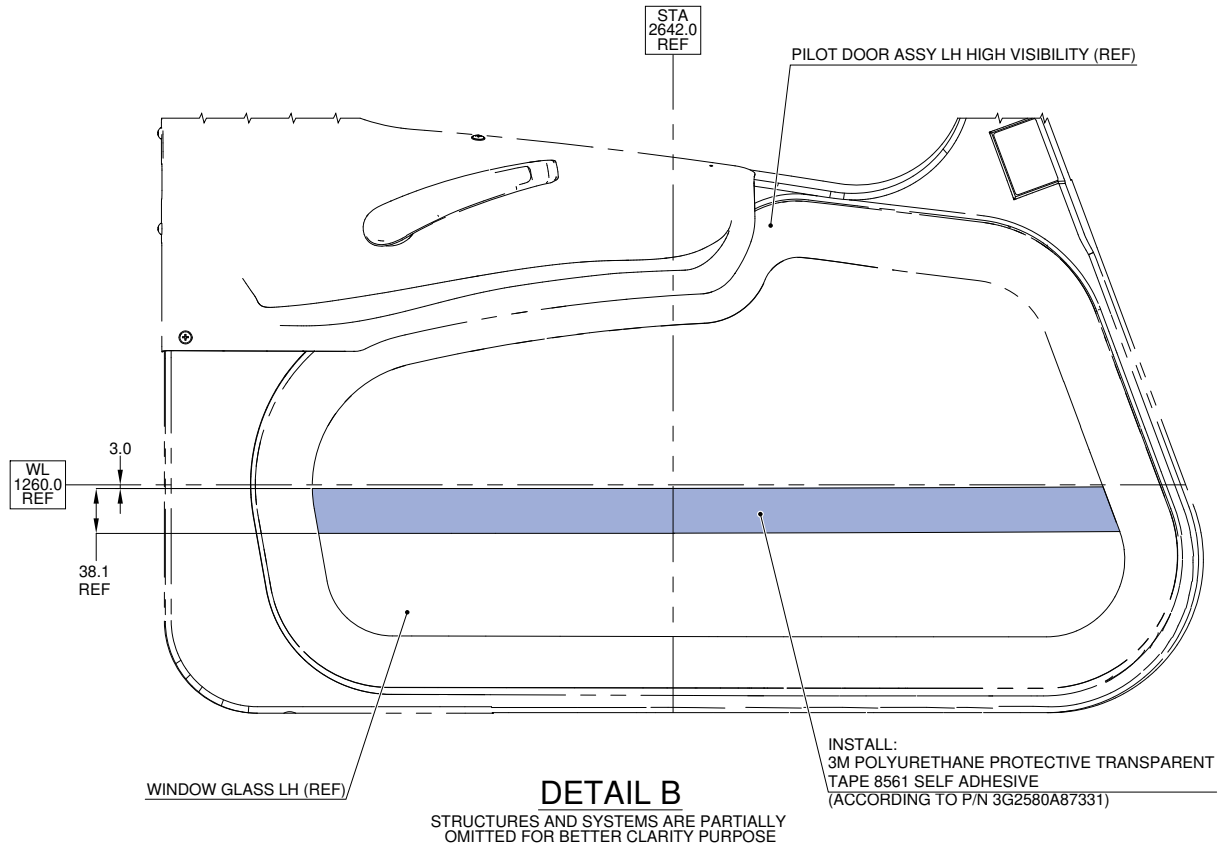

**SECTION C-C**  
STRUCTURES AND SYSTEMS ARE PARTIALLY OMITTED FOR BETTER CLARITY PURPOSE

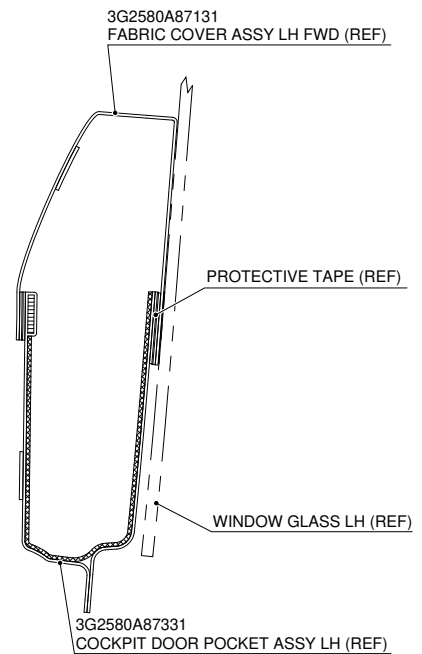

**SECTION D-D**  
STRUCTURES AND SYSTEMS ARE PARTIALLY OMITTED FOR BETTER CLARITY PURPOSE

**Figure 2**



Please send to the following address:  <b>LEONARDO S.p.A.</b> <b>CUSTOMER SUPPORT &amp; SERVICES - ITALY</b>  <b>PRODUCT SUPPORT ENGINEERING &amp; LICENSES DEPT.</b> Via Giovanni Agusta, 520 21017 Cascina Costa di Samarate (VA) - ITALY Tel.: +39 0331 225036 Fax: +39 0331 225988	<b>SERVICE BULLETIN COMPLIANCE FORM</b>	Date:
	Number:	
	Revision:	

Customer Name and Address:	Telephone:
	Fax:
	B.T. Compliance Date:

Helicopter Model	S/N	Total Number	Total Hours	T.S.O.

Remarks:

Information:

We request your cooperation in filling this form, in order to keep out statistical data relevant to aircraft configuration up-to-date. The form should be filled in all its parts and sent to the above address or you can communicate the application also via Technical Bulletin Application Communication Section placed in Leonardo AW Customer Portal - MyCommunications Area. We thank you beforehand for the information given.