SERVICE BULLETIN

N° **139-524**

DATE: February 19, 2020

REV. : A - January 27, 2022

TITLE

ATA 25 - LIFERAFT RESERVOIR ASSEMBLY ALIGNMENT LABEL POSITIONING

REVISION LOG

Liferaft reservoirs already compliant with the previous issue of this Service Bulletin are affected by the Revision A.

After the Revision of Dart Service Bulletin, Leonardo issues the present Revision to introduce the new alignment label positioning.

Revision bars identify changes.

1. PLANNING INFORMATION

A. EFFECTIVITY

NOTE

This Service Bulletin is NOT applicable to LH/RH liferaft reservoirs having the Dart Aerospace SB2018-09 Rev.E already marked on the component logcard, even if their serial number is mentioned below.

LH liferaft reservoir P/N 3G2560V01251 with serial number up to VT172867 and with serial number up to 17007.

RH liferaft reservoir P/N 3G2560V01951 with serial number up to VT170621 and with serial number up to 17009.

B. COMPLIANCE

Before the installation on the aircraft of LH liferaft reservoir P/N 3G2560V01251 and/or RH liferaft reservoir P/N 3G2560V01951.

C. CONCURRENT REQUIREMENTS

N.A.

D. REASON

This Service Bulletin is issued in order to provide all the necessary instructions on how to comply with Dart Aerospace SB2018-09 Rev.E.

To guarantee the right installation of liferaft reservoir on the helicopter, a visual inspection of its alignment label is deemed necessary and, in case of need, label repositioning is required.

E. DESCRIPTION

The AW139 Emergency Float kit with liferafts utilizes a system of pull cables as the method to activate and release compressed gas from the liferaft cylinders into the liferafts. Proper positioning of the liferaft reservoirs during installation ensures that there is an adequate margin of safety in the pull cables to prevent inadvertent inflations. The positioning of the liferaft reservoirs is based on alignment labels installed on the reservoirs.

This Service Bulletin provides all the necessary instructions for the inspection of the LH/RH liferaft reservoir P/N 3G2560V01251 and P/N 3G2560V01951 (DART P/N 650.4703 & 650.4704) to verify that the liferaft reservoir alignment labels

P/N 600.1410 are installed in their designed locations. This SB also includes corrective actions should the labels be located incorrectly.

F. APPROVAL

The technical content of this Service Bulletin is approved under the authority of DOA nr. EASA.21.J.005. For helicopters registered under other Aviation Authorities, before applying the Service Bulletin, applicable Aviation Authority approval must be checked within Leonardo Helicopters customer portal.

EASA states mandatory compliance with inspections, modifications or technical directives and related time of compliance by means of relevant Airworthiness Directives. If an aircraft listed in the effectivity embodies a modification or repair not LHD certified and affecting the content of this Service Bulletin, it is responsibility of the Owner/Operator to obtain a formal approval by Aviation Authority having jurisdiction on the aircraft, for any adaptation necessary before incorporation of the present Service Bulletin.

G. MANPOWER

To comply with this Service Bulletin one (1) MMH is deemed necessary.

MMH are based on hands-on time and can change with personnel and facilities available.

H. WEIGHT AND BALANCE

N.A.

I. REFERENCES

1) PUBLICATIONS

Following Data Modules refer to AMP:

<u>DATA MODULE</u>	<u>DESCRIPTION</u>	<u>PART</u>
DM01 39-A-00-20-00-00A-120A-A	Helicopter on ground for a safe maintenance	-
DM02 39-E-25-62-01-00A-720A-K	Left bottle assembly - Install procedure	-
DM03 39-E-25-62-02-00A-720A-K	Right bottle assembly - Install procedure	-

2) ACRONYMS & ABBREVIATIONS

AMD	Aircraft Material Data Information
AMP	Aircraft Maintenance Publication
DM	Data Module

DOA	Design Organization Approval
EASA	European Aviation Safety Agency
IPD	Illustrated Parts Data
ITEP	Illustrated Tools and Equipment Publication
LH	Left Hand
LHD	Leonardo Helicopters Division
MMH	Maintenance Man Hours
MMIR	Maintenance Malfunction Information Report
P/N	Part Number
RH	Right Hand
SB	Service Bulletin

3) ANNEX

Annex A DART Aerospace SB2018-09 Rev.E, dated 12/01/21.

J. PUBLICATIONS AFFECTED

N.A.

K. SOFTWARE ACCOMPLISHMENT SUMMARY

N.A.

2. MATERIAL INFORMATION

A. REQUIRED MATERIALS

1) PARTS

#	P/N	ALTERNATIVE P/N	DESCRIPTION	Q.TY	LVL	NOTE	LOG P/N
1	600.1410		Alignment label	AR	.	(1)(2)	-

Refer also to IPD for the spares materials required to comply with the AMP DMs referenced in the accomplishment instructions.

2) CONSUMABLES

The following consumable materials, or equivalent, are necessary to accomplish this Service Bulletin:

#	SPEC./LHD CODE NUMBER	DESCRIPTION	Q.TY	NOTE	PART
2	TT-I-735, Grade A	Isopropyl alcohol (C039)	AR	(3)	-

Refer also to AMDI for the consumable materials required to comply with the AMP DM referenced in the accomplishment instructions.

3) LOGISTIC MATRIX

N.A.

NOTE

- (1) Q.ty 1 of this item is already installed on each liferaft reservoir P/N 3G2560V01251 and P/N 3G2560V01951. It must be replaced only if required by the accomplishment instructions.
- (2) Q.ty 1 of this item is necessary for each reservoir requiring the label replacement.
- (3) Item to be procured as local supply.

B. SPECIAL TOOLS

The following special tools, or equivalent, are necessary to accomplish this Service Bulletin:

#	P/N	DESCRIPTION	Q.TY	NOTE	PART
3	601.2382	Diffuser cap	1	(B1)	-

Refer also to ITEP for the special tools required to comply with the AMP DM referenced in the accomplishment instructions.

SPECIAL TOOLS NOTE

(B1) Item already supplied with reservoirs P/N 3G2560V01251 and P/N 3G2560V01951.

C. INDUSTRY SUPPORT INFORMATION

WARRANTY: Owners/Operators who comply with the instructions of this Service Bulletin no later than the applicable date in the “Compliance” section will be eligible to receive necessary replacements on free of charge basis, except for Consumable Materials and Special Tools.

NOTE: Customers who fail to comply with the instructions in this Service Bulletin before the compliance date are not eligible for the aforementioned special policy.

Please Issue relevant MMIR form to your Warranty Administration Dpt.

3. ACCOMPLISHMENT INSTRUCTIONS

GENERAL NOTES

- a) Place an identification tag on all components that are re-usable, including the attaching hardware that has been removed to gain access to the modification area and adequately protect them until their later re-use.
 - b) Shape the cables in order to prevent interference with the structure and the other existing installations, using where necessary suitable lacing cords.
 - c) Let adhesive cure at room temperature for at least 24 hours unless otherwise specified.
 - d) All lengths are in mm.
-
1. In accordance with AMP DM 39-A-00-20-00-00A-120A-A, prepare the helicopter on ground for a safe maintenance. Disconnect the battery, all electrical power sources and/or the external power supply.

WARNING

- SAFETY PINS SHALL BE INSTALLED INTO THE INFLATION HANDLE AND INFLATION VALVES PRIOR TO WORKING WITH THE SYSTEM. FAILURE TO DO SO CAN RESULT IN INJURY OR DEATH.
- A DIFFUSER CAP SHALL BE INSTALLED ONTO THE OUTLET OF EACH RESERVOIR ASSEMBLY AFTER DISCONNECTING THE HOSE FITTING, AND PRIOR TO REMOVING THE RESERVOIR ASSEMBLY FROM THE AIRCRAFT. THE RESERVOIR SHALL BE SECURED USING A BELT VISE OR OTHER METHOD TO PREVENT ANY ROLLING OR FALLING DURING HANDLING. GREAT CARE SHALL BE TAKEN WHEN WORKING AROUND CHARGED CYLINDERS. FAILURE TO DO SO CAN RESULT IN INJURY OR DEATH.

2. In accordance with the applicable steps of Annex A “SB2018-09 Rev.E”, paragraph 1.1 “Reservoir alignment label replacement”, perform the visual inspection of the reservoir/reservoirs about to be installed on the aircraft to check the alignment label P/N 600.1410 current position.
3. In accordance with the applicable steps of Annex A “SB2018-09 Rev.E”, paragraph 1.1 “Reservoir alignment label replacement”, if necessary, install the label in the correct position.
4. Install the inspected bottle assembly/assemblies on the helicopter, in accordance with the applicable AMP DM:
 - 39-E-25-62-01-00A-720A-K - Left bottle assembly - Install procedure;
 - 39-E-25-62-02-00A-720A-K - Right bottle assembly - Install procedure.
5. Record for compliance with Dart Aerospace SB2018-09 Rev.E on the reservoir/reservoirs logcard.
6. Return the helicopter to flight configuration and record for compliance with this Service Bulletin on the helicopter logbook.
7. Send the attached compliance form to the following mail box:

engineering.support.lhd@leonardocompany.com

As an alternative, gain access to My Communications section on Leonardo WebPortal and compile the “Service Bulletin Application Communication”.

ANNEX A

DART AEROSPACE SERVICE BULLETIN SB2018-09 REV. E |
LIFERAFT RESERVOIR ASSEMBLY ALIGNMENT LABEL
POSITIONING FOR AW139 EMERGENCY FLOAT
KITS W/ LIFERAFTS



3030 Enterprise Court, Suite A, Vista, California 92081-8347
PH: +1 760-724-5300 FAX: +1 760-509-1562
www.dartaerospace.com

Service Bulletin

Document Number: SB2018-09

Date: 2021-JAN-12

Revision: E

Effective Models:

LHD P/N	DART P/N	Involved S/N's	Item Description
3G2560V01251	650.4703	VT172867or Lower 17007 or Lower	AW139 Liferaft Reservoir Assemblies
3G2560V01951	650.4704	VT170621or Lower 17009 or Lower	AW139 Liferaft Reservoir Assemblies

NOTE: This Service Bulletin is sent to the operators of record for the model aircraft as shown above. If an aircraft has been leased or sold, please send this service bulletin to the new operator.

This document is being provided to Leonardo Helicopters Division (LHD) and is the property of Apical Industries dba DART Aerospace (DA) and constitutes trade secrets for the purpose of the Trade Secrets and Freedom of Information Act. Disclosures to any party for any reason without the permission of DA is prohibited, except that disclosures may be made within the LHD organization consistent with the need to evaluate DA's technical data.



SUBJECT:
SERVICE BULLETIN
REFERENCE DRAWING:
650.4700

DOCUMENT NO:
SB2018-09
Rev. E
2021-JAN-12

LOG OF REVISIONS

Revision	Date	Pages	Description	Reason Code <small>(Internal Use Only)</small>	Approval
N/C-D			See Previous Revisions		
E	2021-JAN-12	All CVR	Date and Revision Updated Effectivity	DC	J. Gardiner 



SUBJECT:
SERVICE BULLETIN
REFERENCE DRAWING:
650.4700

DOCUMENT NO:
SB2018-09
Rev. E
2021-JAN-12

SAFETY SUMMARY

GENERAL PRECAUTIONS

- Personal Protective Equipment (PPE) must be worn when exposed to flying particles, liquid chemicals, or other potential hazards to the skin, eyes, ears, or respiratory system.
- Make sure that the work area is free from dirt and foreign matter and contaminants that could otherwise damage functionality.
- Failure to comply with or deviate from the procedure may negatively affect the equipment. It is the operator's responsibility to comply with these procedures.

DEFINITIONS

WARNING: THIS INDICATES INFORMATION THAT, IF NOT FOLLOWED, COULD RESULT IN PERSONAL INJURY, DEATH, OR LONG-TERM HEALTH CONDITIONS.

CAUTION: THIS INDICATES INFORMATION THAT, IF NOT FOLLOWED, MAY RESULT IN DAMAGE TO OR DESTRUCTION OF EQUIPMENT, OR THE LOSS OF MISSION EFFECTIVENESS.

NOTE: This indicates information that aids in understanding or provides additional detail on the methods of a procedure.



SUBJECT:
SERVICE BULLETIN
REFERENCE DRAWING:
650.4700

DOCUMENT NO:
SB2018-09
Rev. E
2021-JAN-12

A. Subject

Liferaft Reservoir Assembly Alignment Label Positioning for AW139 Emergency Float Kits w/ Liferafts.

B. Background

The AW139 Emergency Float Kits w/ Liferafts utilizes a system of pull cables as the method to activate and release compressed gas from the liferaft cylinders into the liferafts. Proper positioning of the Liferaft Reservoir Assemblies during installation ensures that there is an adequate margin of safety in the pull cables to prevent inadvertent inflations. The positioning of the Liferaft Reservoirs is based on Alignment Labels that are installed on the reservoirs.

C. Action

This Service Bulletin (SB) provides instructions for the inspection of the DART P/N 650.4703 & 650.4704 AW139 Liferaft Reservoir Assemblies to verify that the P/N 600.1410 AW139 Liferaft Reservoir Alignment Labels are installed in their designed locations.

This SB also includes corrective actions should the labels be located incorrectly.

LHD P/N	DART P/N	Item Description
3G2560V01251	650.4703	AW139 Liferaft Reservoir Assemblies
3G2560V01951	650.4704	AW139 Liferaft Reservoir Assemblies

D. Compliance

This SB is MANDATORY, and all installed kits must be inspected. Compliance time shall be defined by Leonardo Helicopters

E. Manpower

Maintenance-Man-Hours are based on hands-on time and can change per facility and based upon the availability of qualified personnel. The estimated time of completion for this SB is one hour. This SB can be implemented at any maintenance level.

If not previously implemented, the procedure described in this SB shall be executed by DART during D-Level maintenance activities.

F. Weight and Balance

There is no impact on the weight and balance of the aircraft due to this Service Bulletin.

G. Affected Publications

No documents are affected.

H. Approval

The resultant modifications described in the Accomplishment Instructions (Page 6) have been shown to comply with the applicable regulations. The content of this document is approved by Leonardo Helicopters Division (formerly AgustaWestland S.p.A.), Design Authority of the AW139 Emergency Float Kits w/Liferafts.



SUBJECT:
SERVICE BULLETIN
REFERENCE DRAWING:
650.4700

DOCUMENT NO:
SB2018-09
Rev. E
2021-JAN-12

I. Material

Materials needed to perform this SB are listed below.

Description	P/N	Source	Use
Alignment Label	600.1410	DART	Aid in liferaft reservoir positioning during installation

J. Tooling

Tools needed to perform this SB are listed below.

Description	P/N	Source	Use
Diffuser Cap	601.2382	DART	Safety cap for valve outlet port



SUBJECT:
SERVICE BULLETIN
REFERENCE DRAWING:
650.4700

DOCUMENT NO:
SB2018-09
Rev. E
2021-JAN-12

ACCOMPLISHMENT INSTRUCTIONS

1.0 P/N 650.4700 SERIES LIFERAFT RESERVOIR ASSEMBLY

The Dart P/N 650.4700 Series Liferaft Reservoir Assembly consists of:

- Cylinder
- Mechanical valve assembly
- Labels

The P/N 600.1410 AW139 Liferaft Reservoir Alignment Label aids in the positioning of the reservoir onto the aircraft during installation.

WARNING: SAFETY PINS SHALL BE INSTALLED INTO THE INFLATION HANDLE AND INFLATION VALVES PRIOR TO WORKING WITH THE SYSTEM. FAILURE TO DO SO CAN RESULT IN INJURY OR DEATH.

WARNING: A DIFFUSER CAP SHALL BE INSTALLED ONTO THE OUTLET OF EACH RESERVOIR ASSEMBLY AFTER DISCONNECTING THE HOSE FITTING, AND PRIOR TO REMOVING THE RESERVOIR ASSEMBLY FROM THE AIRCRAFT. THE RESERVOIR SHALL BE SECURED USING A BELT VISE OR OTHER METHOD TO PREVENT ANY ROLLING OR FALLING DURING HANDLING. GREAT CARE SHALL BE TAKEN WHEN WORKING AROUND CHARGED CYLINDERS. FAILURE TO DO SO CAN RESULT IN INJURY OR DEATH.

1.1 RESERVOIR ALIGNMENT LABEL REPLACEMENT

The herein described procedure is intended to be applied on reservoirs already removed from the A/C.

For Each Reservoir:

1. Verify that the P/N 601.2382 Diffuser Cap and the valve safety pin are installed in the valve of the Liferaft Reservoir Assembly.
2. Fix the removed Reservoir on a flat surface. Secure it to the surface by means of belts by keeping the valve outlet port up as shown in Figure 1.

SUBJECT:
SERVICE BULLETIN
REFERENCE DRAWING:
650.4700

DOCUMENT NO:
SB2018-09
Rev. E
2021-JAN-12



Figure 1: Securing Liferaft Reservoir

3. Verify the P/N 600.1410 Alignment Label is installed per Figure 2 (LH Side) or Figure 3 (RH Side).
4. If the label is correctly installed, record compliance onto the component log card. If the label is misaligned, proceed to Step 5).

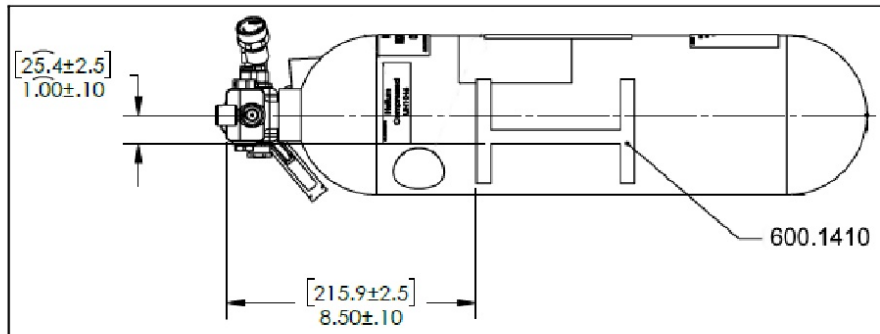

Figure 2: P/N 3G2560V01251/650.4703 Left Hand Reservoir Label Position (Looking Down)



SUBJECT:
SERVICE BULLETIN
REFERENCE DRAWING:
650.4700

DOCUMENT NO:
SB2018-09
Rev. E
2021-JAN-12

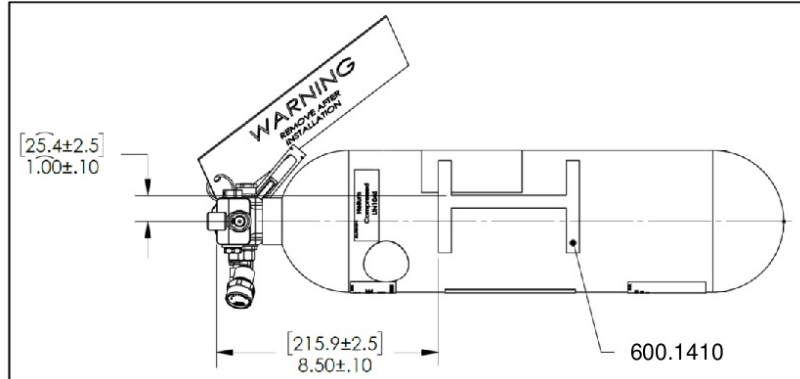

Figure 3: P/N 3G2560V01951/ 650.4704 Right Hand Reservoir Label Position (Looking Down)

5. Carefully remove the alignment label starting from a corner edge. Take care not to cause damage to the outer layer of the cylinder.
6. Remove any excess adhesive from the surface of the cylinder. Any commercially available non-abrasive adhesive removal solution is allowable.
7. Clean and dry the surface prior to installation of new alignment label.

NOTE: If the Alignment Label 600.1410 will cover the DOT label already installed on the cylinder, record the DOM of the cylinder on an alternate location by means of a permanent marker and in the component log card.

8. Remove the adhesive backing from the Alignment Label and install on the cylinder per Figure 2 or Figure 3. Apply pressure to the labels and remove any air bubbles.



SUBJECT:
SERVICE BULLETIN
REFERENCE DRAWING:
650.4700

DOCUMENT NO:
SB2018-09
Rev. E
2021-JAN-12

2.0 SB RECORD

1. Record compliance of this SB in the component log card.
2. Fill out Record Sheet and send it to DART Customer Support (support@dartaero.com)

Table 1: Record Sheet

CUSTOMER	Aircraft Model	Aircraft Serial Number	Aircraft Tail number	Kit Part number	Kit Serial Number

Please send to the following address: LEONARDO S.p.A. CUSTOMER SUPPORT & SERVICES - ITALY PRODUCT SUPPORT ENGINEERING & LICENSES DEPT. Via Giovanni Agusta, 520 21017 Cascina Costa di Samarate (VA) - ITALY Tel.: +39 0331 225036 Fax: +39 0331 225988		SERVICE BULLETIN COMPLIANCE FORM		Date:	
		Number:			
		Revision:			
Customer Name and Address:			Telephone:		
			Fax:		
			B.T. Compliance Date:		
Helicopter Model	S/N	Total Number	Total Hours	T.S.O.	
Remarks:					
Information: We request your cooperation in filling this form, in order to keep out statistical data relevant to aircraft configuration up-to-date. The form should be filled in all its parts and sent to the above address or you can communicate the application also via Technical Bulletin Application Communication Section placed in Leonardo AW Customer Portal - MyCommunications Area. We thank you beforehand for the information given.					