SERVICE BULLETIN

N° **139-360**

DATE: June 14, 2017

REV. : A - October 22, 2021

TITLE

ATA 24 - KIT BATTERY START IN PARALLEL 44 Ah AND 27 Ah

REVISION LOG

Helicopters that have complied with the first issue of this Service Bulletin do not need any additional action.

Rev. A of this Service Bulletin is issued to:

- update the Service Bulletin to the latest standard;
- introduce the accomplishment instructions and part list required to install the kit on AB139/AW139 helicopters from S/N 31005 to S/N 31157 (except S/N 31007) and from 41001 to S/N 41200 (added as Part I).

An appropriate entry should be made in the aircraft log book upon accomplishment.
If ownership of aircraft has changed, please, forward to new owner.

1. PLANNING INFORMATION

A. EFFECTIVITY

Part I: AB139/AW139 helicopters from S/N 31005 to S/N 31157 (except S/N 31007) and from 41001 to S/N 41023.

Part II: AW139 helicopters from S/N 31400 to S/N 31699, from S/N 41300 to S/N 41499, from S/N 31700 onwards and from S/N 41500 onwards.

B. COMPLIANCE

At Customer's option.

C. CONCURRENT REQUIREMENTS

N.A.

D. REASON

This Service Bulletin is issued in order to provide all necessary instruction for installation of Kit Main Battery in parallel P/N 4G2430F00711 or P/N 4G2430F00713.

E. DESCRIPTION

The Main and Auxiliary batteries in parallel configuration improves battery engines start capability for helicopters equipped with the MAIN battery (44 Ah 20 cells) and the AUX battery (27 Ah), whose installation is a pre-requisite for compliance with this Service Bulletin.

In particular, during engine start, the MAIN battery (44 Ah 20 cells) and the AUX battery (27 Ah) are connected in parallel through a contactor. This functionality is inhibited in flight by WOW signal.

Two DC/DC converters are added to guarantee uninterruptible power on the Essential busses, during engines start.

This installation includes a relay in the electrical power generation and distribution system operated by the ENG MODE switch. When the two ENG MODE switches are set in the GI or FLT position, a relay connects the two batteries in parallel for the engine starting phase and activates the BATT OFF LINE caution indication to the pilots.

Part I of this Service Bulletin provides all necessary instructions for installation of kit battery start in parallel 44Ah and 27Ah P/N 4G2430F00711 on helicopters from S/N 31005 to S/N 31157 (except S/N 31007) and from 41001 to S/N 41200.

Part II of this Service Bulletin provides all necessary instructions for installation of kit battery start in parallel 44Ah and 27Ah P/N 4G2430F00713 on helicopters from

S/N 31400 to S/N 31699, from S/N 41300 to S/N 41499, from S/N 31700 onwards and from S/N 41500 onwards.

NOTE

Installation of auxiliary battery 27Ah is managed with SB139-045 for AB139/AW139 short nose helicopters equipped with Auxiliary battery 13Ah.

Installation of auxiliary battery 27Ah is managed with SB139-138 for AW139 long nose helicopters enhanced equipped with Auxiliary battery 13Ah.

NOTE

Conversion of Main battery 44Ah 19 cells to Main Battery 44AH 20 cells is managed with SB139-247.

NOTE

Supplement n°85 of RFM (Rotorcraft Flight Manual) is dedicated to kit batteries in parallel (improved engine starting) and contains information about limitations, procedures and performance data.

F. APPROVAL

The technical content of this Service Bulletin is approved under the authority of DOA nr. EASA.21.J.005. For helicopters registered under other Aviation Authorities, before applying the Service Bulletin, applicable Aviation Authority approval must be checked within Leonardo Helicopters customer portal.

EASA states mandatory compliance with inspections, modifications or technical directives and related time of compliance by means of relevant Airworthiness Directives. If an aircraft listed in the effectivity embodies a modification or repair not LHD certified and affecting the content of this Service Bulletin, it is responsibility of the Owner/Operator to obtain a formal approval by Aviation Authority having jurisdiction on the aircraft, for any adaptation necessary before incorporation of the present Service Bulletin.

G. MANPOWER

To comply with this Service Bulletin, the following MMH are deemed necessary.

Part I: approximately two-hundred (200) MMH.

Part II: approximately two-hundred and twenty (220) MMH.

MMH are based on hands-on time and can change with personnel and facilities available.

H. WEIGHT AND BALANCE

PART I

WEIGHT (kg)		9.64
	ARM (mm)	MOMENT (kgmm)
LONGITUDINAL BALANCE	4047	39013.1
LATERAL BALANCE	110	1060.4

PART II

WEIGHT (kg)		10.34
	ARM (mm)	MOMENT (kgmm)
LONGITUDINAL BALANCE	4061	41990.74
LATERAL BALANCE	112	1158.08

I. REFERENCES

1) PUBLICATIONS

Following Data Modules refer to AMP:

<u>DATA MODULE</u>	<u>DESCRIPTION</u>	<u>PART</u>
DM01 39-A-00-20-00-00A-120A-A	Helicopter on ground for a safe maintenance	I, II
DM02 39-A-06-41-00-00A-010A-A	Access door panel	I, II
DM03 39-A-11-00-01-00A-720A-A	Decal – Install procedure	I, II
DM04 39-A-24-32-01-00A-520A-A	Battery - Remove procedure	I, II
DM05 39-B-24-32-01-00A-520A-K	Battery - Remove procedure	I, II
DM06 39-C-24-32-01-00A-520A-K	Battery - Remove procedure	I, II
DM07 39-C-24-32-01-00A-720A-K	Battery - Install procedure	I, II
DM08 39-C-24-32-01-02A-320A-K	Battery - Check procedure	I, II
DM09 39-A-24-32-02-00A-520A-A	Battery - Remove procedure	I, II
DM10 39-D-24-32-02-00A-720A-K	Battery - Install procedure	I, II
DM11 39-D-24-32-02-02A-320A-K	Battery - Check procedure	I, II
DM12 39-B-24-33-03-00A-720A-K	Relay K310 – Install procedure	I, II
DM13 39-A-24-34-01-00A-720A-K	DC-DC converter A449 – Install	I

<u>DATA MODULE</u>	<u>DESCRIPTION</u>	<u>PART</u>
	procedure	
DM14	39-A-24-34-02-00A-720A-K DC-DC converter A450 – Install procedure	I
DM15	39-A-25-82-03-00A-520A-A Lining - Remove procedure	I, II
DM16	39-A-25-82-03-00A-720A-A Lining - Install procedure	I, II
DM17	39-A-25-82-04-00A-720A-A Lining - Install procedure	I, II
DM18	39-A-24-32-00-00A-320C-A Battery power generation system - Operation test	I

Following Data Modules refer to CSRP:

<u>DATA MODULE</u>	<u>DESCRIPTION</u>	<u>PART</u>
DM19	CSRP-A-51-42-00-00A-720A-D Potted inserts – Install procedure	I, II

2) ACRONYMS

AMDI	Aircraft Material Data Information
AMP	Aircraft Maintenance Publication
CSRP	Common Structural Repair Publication
DC	Direct Current
DM	Data Module
DOA	Design Organization Approval
EASA	European Aviation Safety Agency
IPD	Illustrated Part Data
ITEP	Illustrated Tools and Equipment Publication
LHD	Leonardo Spa Helicopters
LS	Local Supply
MMH	Maintenance Man-Hours
SB	Service Bulletin
WOW	Weight on Wheel

3) ANNEX

N.A.

J. PUBLICATIONS AFFECTED

N.A.

K. SOFTWARE ACCOMPLISHMENT SUMMARY

N.A.

2. MATERIAL INFORMATION

A. REQUIRED MATERIALS

1) PARTS

PART I

#	P/N	ALTERNATIVE P/N	DESCRIPTION	Q.TY	LVL	NOTE	LOG P/N
1	4G2430F00711		KIT BATTERIES START IN PARALLEL	REF	.		-
2	3G5310P22611		BATTERIES START IN PARALLEL RETROMOD	REF	..		-
3	3G5310A89611		BATTERIES START IN PARALLEL STRUCTURAL PROVISION	REF	..		-
4	3G5315A17851		Cover	1	...		139-360L3
5	3G5315A17951		Cover	1	...		139-360L3
6	3G5315A40551		Cover	1	...		139-360L3
7	A813A08CM		Insert	2	...		139-360L3
8	A813A3CM		Insert	2	...		139-360L3
9	AW001SB001A		Bracket	3	...		139-360L3
10	NAS1149DN832K		Washer	8	...		139-360L3
11	NAS1802-08-4		Screw	4	...		139-360L3
12	NAS1802-08-5		Screw	4	...		139-360L3
13	NAS1832C3-3		Insert	12	...		139-360L3
14	NAS1836-08-08		Insert	6	...		139-360L3
15	NAS1836C08-13		Insert	4	...		139-360L3
16	3G2430A00411		BATTERIES START IN PARALLEL ELECTRICAL INSTALLATION	REF	..		-
17	1152620-3		Contactora 300a	1	...		139-360L3
18	3G2460A00153	3G2460A00153	Bus bar	2	...		139-360L3
19	3G2460A02251		Bus bar	1	...		139-360L3
20	3G2460A02351		Bus bar	1	...		139-360L3
21	3G9A11A01901		Batteries Start In Parallel C/A (A1A19)	1	...	(1)	139-360L3
22	3G9A11B01501		Batteries Start In Parallel C/A (A1B15)	1	...	(2)	139-360L3
23	3G9A11B01601		Batteries Start In Parallel C/A (A1B16)	1	...	(3)	139-360L3
24	3G9A11B01701		Batteries Start In Parallel C/A (A1B17)	1	...	(4)	139-360L3
25	3G9A11B01801		Batteries Start In Parallel C/A (A1B18)	1	...	(5)	139-360L3
26	3G9A11B01901		Batteries Start In Parallel C/A (A1B19)	1	...	(6)	139-360L3
27	3G9B01A08001		Batteries Start In Parallel C/A (B1A80)	1	...		139-360L3
28	3G9B01A08101		Batteries Start In Parallel C/A (B1A81)	1	...		139-360L3
29	3G9B01B09801		Batteries Start In Parallel C/A (B1B98)	1	...		139-360L3
30	3G9B01B09901		Batteries Start In Parallel C/A (B1B99)	1	...		139-360L3
31	A363A01		Terminal,stud	2	...		139-360L3
32	A366A3E10C		Stud	4	...		139-360L3
33	A366A3E18C75		Stud	1	...		139-360L3

S.B. N°139-360

DATE: June 14, 2017

REVISION: A - October 22, 2021

#	P/N	ALTERNATIVE P/N	DESCRIPTION	Q.TY	LVL	NOTE	LOG P/N
34	A366A3E22C		Stud	1	...		139-360L3
35	A584A01		Electrical terminal	3	...		139-360L3
36	A584A02		Electrical terminal	9	...		139-360L3
37	A584A05		Electrical terminal	2	...		139-360L3
38	A631A01A		Cable bundles	2	...		139-360L3
39	AN6-6A		Bolt	3	...		139-360L3
40	AN6-7A		Bolt	1	...		139-360L3
41	AW001CB02H		Clamp	1	...		139-360L3
42	AW001CB08H		Clamp	5	...		139-360L3
43	AW001CL001-N6		Support	1	...		139-360L3
44	ED300A449		Decal	1	...		139-360L3
45	ED300A450		Decal	1	...		139-360L3
46	ED300CB453		Decal	1	...		139-360L3
47	ED300CB454		Decal	1	...		139-360L3
48	ED300CB455		Decal	1	...		139-360L3
49	ED300GS84		Decal	1	...		139-360L3
50	ED300GS85		Decal	1	...		139-360L3
51	ED300K309		Decal	1	...		139-360L3
52	ED300K310		Decal	1	...		139-360L3
53	M12883/53-001		Relay	1	...		139-360L3
54	M83536/2-028M		Relay	1	...		139-360L3
55	MS21042L3		Nut	5	...		139-360L3
56	MS21042L6		Nut	4	...		139-360L3
57	MS21919WDG9	AS21919WDG09	Clamp	1	...		139-360L3
58	MS24693-S47		Screw	2	...		139-360L3
59	MS25244-35		Circuit breaker	2	...		139-360L3
60	MS3320-5		Circuit breaker	1	...		139-360L3
61	MS35206-227		Screw	2	...		139-360L3
62	MS35206-263		Screw	6	...		139-360L3
63	NAS1149D0332J		Washer	13	...		139-360L3
64	NAS1149D0632J		Washer	8	...		139-360L3
65	NAS1149DN616J		Washer	2	...		139-360L3
66	NAS1149DN832J		Washer	6	...		139-360L3
67	NAS1190E3P5AK		Washer	8	...		139-360L3
68	NAS43DD3-40N		Spacer	1	...		139-360L3
69	RH40C		DC to DC converter	2	...		139-360L3
70	33204-002		Main battery 44 Ah	1	.	(14)	-

PART II

#	P/N	ALTERNATIVE P/N	DESCRIPTION	Q.TY	LVL	NOTE	LOG P/N
71	4G2430F00713		KIT BATTERY START IN PARALLEL 27 Ah AND 44 Ah	REF	.		-
72	3G2430A00413		BATTERIES START IN PARALLEL ELECTRICAL INSTALLATION	REF	..		-
73	1152620-3		Contactora 300A	1	...		139-360L2
74	3G2460A02251		Bus bar	1	...		139-360L2
75	3G2460A02351		Bus bar	1	...		139-360L2
76	3G9A01A51801		Batteries start in parallel C/A (A1A518)	1	...		139-360L2
77	3G9A01B48001		Batteries start in parallel C/A (A1B480)	1	...		139-360L2
78	3G9A11A01811		Batteries start in parallel C/A	1	...	(7)	139-360L2

#	P/N	ALTERNATIVE P/N	DESCRIPTION	Q.TY	LVL	NOTE	LOG P/N
			(A1A18)				
79	3G9A11A01911		Batteries start in parallel C/A (A1A19)	1	...	(8)	139-360L2
80	3G9A11B01111		Batteries start in parallel C/A (A1B11)	1	...	(9)	139-360L2
81	3G9A11B01211		Batteries start in parallel C/A (A1B12)	1	...	(10)	139-360L2
82	3G9A11B01311		Batteries start in parallel C/A (A1B13)	1	...	(11)	139-360L2
83	3G9A11B01411		Batteries start in parallel C/A (A1B14)	1	...	(12)	139-360L2
84	3G9B01A89101		Batteries start in parallel C/A (B1A891)	1	...		139-360L2
85	3G9B01B76501		Batteries start in parallel C/A (B1B765)	1	...		139-360L2
86	A363A01		Terminal, stud	2	...		139-360L2
87	A366A3E08C75		Stud	1	...		139-360L2
88	A366A3E10C75		Stud	1	...		139-360L2
89	A366A3E16C75		Stud	3	...		139-360L2
90	A366A3E18C75		Stud	1	...		139-360L2
91	A388A3E18C75		Standoff	1	...		139-360L2
92	A388A3E22C75		Standoff	2	...		139-360L2
93	A584A01		Nipple	4	...		139-360L2
94	A584A02		Nipple	10	...		139-360L2
95	A584A05		Nipple	1	...		139-360L2
96	A631A01A		Spacer	1	...		139-360L2
97	A631A02A		Spacer	1	...		139-360L2
98	AN6-6A		Bolt	1	...		139-360L2
99	AN6-7A		Bolt	1	...		139-360L2
100	AW001CB03H		Clamp	3	...		139-360L2
101	AW001CB05H		Clamp	1	...		139-360L2
102	AW001CB08H		Clamp	8	...		139-360L2
103	AW001CB10H		Clamp	2	...		139-360L2
104	AW001CB12H		Clamp	1	...		139-360L2
105	AW001CL001-N6		Support	1	...		139-360L2
106	AW001CL002A-X1		Support	1	...		139-360L2
107	AW001CL509-N6		Support	1	...		139-360L2
108	AW001TL3A08		Anchor nut	1	...		139-360L2
109	ED300A449		Decal	1	...		139-360L2
110	ED300A450		Decal	1	...		139-360L2
111	ED300CB453		Decal	1	...		139-360L2
112	ED300CB454		Decal	1	...		139-360L2
113	ED300CB455		Decal	1	...		139-360L2
114	ED300GS2021		Decal	1	...		139-360L2
115	ED300GS2023		Decal	1	...		139-360L2
116	ED300K309		Decal	1	...		139-360L2
117	ED300K310		Decal	1	...		139-360L2
118	M83536/2-028M		Relay	1	...		139-360L2

#	P/N	ALTERNATIVE P/N	DESCRIPTION	Q.TY	LVL	NOTE	LOG P/N
119	MS21042L3		Nut	1	...		139-360L2
120	MS21042L6		Nut	2	...		139-360L2
121	MS21043-3		Nut	7	...		139-360L2
122	MS25244-35		Circuit breaker	2	...		139-360L2
123	MS27039-1-05		Screw	4	...		139-360L2
124	MS27039-1-07		Screw	4	...		139-360L2
125	MS27039-1-10		Screw	1	...		139-360L2
126	MS3320-5		Circuit breaker	1	...		139-360L2
127	MS35489-15		Grommet	1	...		139-360L2
128	MS9592-214		Bracket	1	...		139-360L2
129	NAS1149D0332J		Washer	20	...		139-360L2
130	NAS1149D0632J		Washer	4	...		139-360L2
131	NAS1190E3P5AK		Screw	1	...		139-360L2
132	NAS1801-3-8		Screw	1	...		139-360L2
133	NAS1802-3-10		Screw	1	...		139-360L2
134	NAS1802-3-12		Screw	2	...		139-360L2
135	NAS1802-3-24		Screw	1	...		139-360L2
136	NAS1802-3-5		Screw	2	...		139-360L2
137	NAS1802-3-9		Screw	2	...		139-360L2
138	NAS43DD3-34N		Spacer	4	...		139-360L2
139	NAS43DD3-37N		Spacer	1	...		139-360L2
140	NAS43DD3-52N		Spacer	2	...		139-360L2
141	NAS43DD3-60N		Spacer	1	...		139-360L2
142	RH40C		DC to DC converter	2	...		139-360L2
143	3G5310A89613		BATTERIES START IN PARALLEL STRUCTURAL PROVISION	REF	..		-
144	3G5315A29252		Cover	1	...		139-360L1
145	3G5316A97031		Bracket assy	1	...		139-360L1
146	3G5316A97151		Cover	1	...		139-360L2
147	3G5316A97231		Bracket assy	1	...		139-360L1
148	999-5000-30-106	AW007TE-30-106	Insert	14	...		139-360L1
149	A419A004A1A		Support assy, socket relay	1	...		139-360L1
150	A466A222A180		Support, I form	2	...		139-360L1
151	A467A150A180		Plate, drilled, phenolic resin	2	...		139-360L1
152	A467A200A180		Plate, drilled, phenolic resin	1	...		139-360L1
153	AW001SB001A		Bracket	3	...		139-360L1
154	MS20426AD3-7		Rivet	0.1 kg	...		139-360L1
155	MS21071L3		Nut	2	...		139-360L1
156	MS24694-S47		Screw	5	...		139-360L1
157	NAS1149D0332K		Washer	10	...		139-360L1
158	NAS1149DN532K		Washer	2	...		139-360L1
159	NAS1149DN832K		Washer	8	...		139-360L1
160	NAS1802-06-5		Screw	2	...		139-360L1
161	NAS1802-08-4		Screw	2	...		139-360L1
162	NAS1802-08-5		Screw	4	...		139-360L1
163	NAS1802-08-8		Screw	2	...		139-360L1
164	NAS1802-3-4		Screw	2	...		139-360L1

#	P/N	ALTERNATIVE P/N	DESCRIPTION	Q.TY	LVL	NOTE	LOG P/N
165	NAS1802-3-5		Screw	6	...		139-360L1
166	NAS1802-3-8		Screw	2	...		139-360L1
167	NAS1832C3-3		Insert	9	...		139-360L1
168	NAS1836-08-08		Insert	2	...		139-360L1
169	NAS1836-3-09		Insert	2	...		139-360L1
170	NAS1836C08-13		Insert	4	...		139-360L1
BATTERIES START IN PARALLEL STRUCTURAL VARIANT							
171	3G5310P01011			REF	..	(13)	-
172	3G5316A97032		Bracket assy	1	...		-
173	3G5316A97151		Cover	1	...		-
174	33204-002		Main battery 44 Ah	1	.	(14)	-

Refer also to IPD for the spares materials required to comply with the AMP DMs referenced in the accomplishment instructions.

2) CONSUMABLES

The following consumable materials, or equivalent, are necessary to accomplish this Service Bulletin:

#	Spec./LHD code number	DESCRIPTION	Q.TY	NOTE	PART
175	199-05-002 Type II, Class 2 / Code No. 900004603 MMM-A-132	Adhesive EA934NA (C057)	AR	(15)	I, II
176	199-05-002 Type I, Class 2 / Code No. 900000581 MMM-A-132	Adhesive EA9309.3NA (C021)	AR	(15)	I, II
177	CCC-C-46 / Code No. 42501025	Soft lint-free cloth (C011)	AR	(15)	I, II
178	P-D-680 type II / Code No. 505405407	Cleaning solvent Ardrex 5503 (C010)	AR	(15)	I, II
179	TT-N-95-B / Code No. 531055030	Aliphatic Naphtha (C059)	AR	(15)	I, II
180	TT-M-261 / Code No. 32002675	Methyl-Ethyl-Ketone (C005)	AR	(15)	I, II
181	Commercial	Gloves	AR	(15)	I, II
182	Commercial	Toluol (C040)	AR	(15)	I, II
183	Commercial	Isopropyl alcohol (C039)	AR	(15)	I, II
184	AW001CK01HS	Cable-tie	AR	(15)	I, II
185	900004953 or AW001CK03LC	Lacing cord	AR	(15)	I, II

Refer also to AMDI for the consumable materials required to comply with the AMP DMs referenced in the accomplishment instructions.

3) LOGISTIC MATRIX

In order to apply this Service Bulletin, the following Logistic P/N can be ordered in accordance with the applicable notes:

LOGISTIC P/N	Q.TY (PER HELO)	NOTE	PART
139-360L3	1		Part I
139-360L2	1		Part II
139-360L1	1		

LOGISTIC P/N	Q.TY (PER HELO)	NOTE	PART
3G5316A97032	1	(13)	
3G5316A97151	1	(13)	
33204-002	1	(13) (14)	Part I or Part II

NOTES

- (1) Cable assy P/N 3G9A01A01301 (A1A13) will be supplied as part of cable assy P/N 3G9A11A01901 (A1A19).
- (2) Cable assy P/N 3G9A01B01201 (A1B12) will be supplied as part of cable assy 3G9A11B01501 (A1B15).
- (3) Cable assy P/N 3G9A01B01101 (A1B11) will be supplied as part of cable assy 3G9A11B01601 (A1B16).
- (4) Cable assy P/N 3G9A01B01301 (A1B13) will be supplied as part of cable assy 3G9A11B01701 (A1B17).
- (5) Cable assy P/N 3G9A01B01501 (A1B15) will be supplied as part of cable assy 3G9A11B01801 (A1B18).
- (6) Cable assy P/N 3G9A01B01401 (A1B14) will be supplied as part of cable assy 3G9A11B01901 (A1B19).
- (7) Cable assy P/N 3G9A01A51701 (A1A517) will be supplied as part of cable assy P/N 3G9A11A01811 (A1A18).
- (8) Cable assy P/N 3G9A01A51601 (A1A516) will be supplied as part of cable assy P/N 3G9A11A01911 (A1A19).
- (9) Cable assy P/N 3G9A01B48101 (A1B481) will be supplied as part of cable assy P/N 3G9A11B01111 (A1B11).
- (10) Cable assy P/N 3G9A01B48401 (A1B484) will be supplied as part of cable assy P/N 3G9A11B01211 (A1B12).
- (11) Cable assy P/N 3G9A01B48201 (A1B482) will be supplied as part of cable assy P/N 3G9A11B01311 (A1B13).
- (12) Cable assy P/N 3G9A01B48301 (A1B483) will be supplied as part of cable assy P/N 3G9A11B01411 (A1B14).
- (13) Applicable when the 2nd Transponder electrical provision P/N 3G3450A01713 is installed.
- (14) To be ordered only for helicopters equipped with Main Battery 40 Ah P/N 1152552-1.
- (15) Item to be procured as local supply.

B. SPECIAL TOOLS

The following special tools, or equivalent, are necessary to accomplish this Service Bulletin:

#	P/N	DESCRIPTION	Q.TY	NOTE	PART
186	Commercial	Multimeter	1	(B1)	I, II

Refer also to ITEP for the special tools required to comply with the AMP DMs referenced in the accomplishment instructions.

SPECIAL TOOLS NOTE

(B1) Item to be procured as local supply.

C. INDUSTRY SUPPORT INFORMATION

Customization.

3. ACCOMPLISHMENT INSTRUCTIONS

GENERAL NOTES

- a) Place an identification tag on all components that are re-usable, including the attaching hardware that has been removed to gain access to the modification area and adequately protect them until their later re-use.
- b) Shape the cables in order to prevent interference with the structure and the other existing installations, using where necessary suitable lacing cords.
- c) Exercise extreme care during drilling operations to prevent instruments, cables and hoses damage.
- d) After drilling, remove all swarf and sharp edges. Apply on bare metal a light film of primer unless the hole is used for ground connection.
- e) During the installation of bonding braids or components requiring grounding, clean the surface structure in order to obtain a good ground contact.
- f) Let the adhesive cure at room temperature for at least 24 hours unless otherwise specified.
- g) Exposed thread surface and nut must be protected using a layer of tectyl according to MIL-C-16173 grade I.
- h) All lengths are in mm.

PART I

1. In accordance with AMP DM 39-A-00-20-00-00A-120A-A, prepare the helicopter on ground for a safe maintenance. Disconnect the battery, all electrical power sources and/or the external power supply.
2. In accordance with AMP DM 39-A-06-41-00-00A-010A-A, remove access panels 131AL, 132AR, 141DL, 142ER, 142CR, 160AT and 160BT and open access door 213AL, if applicable.
3. In accordance with AMP DM 39-A-25-82-03-00A-520A-A, remove the left hinged lining panel, if applicable.
4. In accordance with AMP DM 39-A-25-82-04-00A-520A-A, remove the right hinged lining panel.

5. In accordance with helicopter configuration and with AMP DM 39-A-24-32-01-00A-520A-A or DM 39-B-24-32-01-00A-520A-K or DM 39-C-24-32-01-00A-520A-K, remove the main battery 40 Ah or 44 Ah 19 cells or 44 Ah 20 cells.
6. In accordance with AMP DM 39-A-24-32-02-00A-520A-A or DM 39-D-24-32-02-00A-520A-K, remove the auxiliary battery 13 Ah or 27 Ah.
7. With reference to Figure 1, perform the batteries start in parallel retromod P/N 3G5310P22611 as described in the following procedure:
 - 7.1 With reference to Figure 1 section A-A, remove n°3 inserts in the indicated positions.
 - 7.2 With reference to Figure 1 section B-B, fill the honeycomb core of the panel STA 1070 P/N 3P5331A07031 by means of EA934NA adhesive.

NOTE

With reference to the following step, it is allowed to remove existing inserts when interference with new inserts installed during the following step is found.

8. With reference to Figures 2 thru 7, perform the batteries start in parallel structural provision P/N 3G5310A89611 as described in the following procedure:
 - 8.1 With reference to Figure 3 view E-E and section G-G, perform n°2 holes $\varnothing 11.48 \div 11.61$ on the right vertical panel.
 - 8.2 In accordance with CSRP DM CSRP-A-51-42-00-00A-720A-D and with reference to Figure 3 section G-G, install n°2 inserts P/N NAS1836-08-08 by means of EA934NA adhesive.
 - 8.3 With reference to Figure 3 view E-E and section F-F, perform n°2 holes $\varnothing 11.48 \div 11.61$ on the right vertical panel.
 - 8.4 In accordance with CSRP DM CSRP-A-51-42-00-00A-720A-D and with reference to Figure 3 section F-F, install n°2 inserts P/N NAS1836-08-08 by means of EA934NA adhesive.
 - 8.5 With reference to Figure 3 view E-E and section F-F, prepare the surface to assure the correct electrical bonding and install bracket P/N AW001SB001A by means of n°2 washers P/N NAS1149DN832K and n°2 screws P/N NAS1802-08-4.
 - 8.6 With reference to Figure 4 detail H and section J-J, perform n°4 holes $\varnothing 14.25 \div 14.38$ on the panel STA 1070.
 - 8.7 In accordance with CSRP DM CSRP-A-51-42-00-00A-720A-D and with reference to Figure 4 section J-J, install n°2 inserts P/N A813A08CM and n°2 inserts P/N A813A3CM by means of EA934NA adhesive.

- 8.8 With reference to Figure 4 detail H, prepare indicated surface to assure the correct electrical bonding.
- 8.9 With reference to Figure 3 view E-E and Figure 4 section J-J, install cover P/N 3G5315A40551 by means of n°2 washers P/N NAS1149DN832K and n°2 screws P/N NAS1802-08-4.
- 8.10 With reference to Figure 5 view C-C and section K-K, perform n°8 holes \varnothing 14.25 ÷ 14.38 on the upper deck assy.

NOTE

If the relay K85 BRACKET MOUNT is not already in the position shown in Figure 6, View B-B, Section M-M and in Figure 9, it is necessary to relocate it according to the details in steps 8.12 thru 8.14 and Figure 9.

- 8.11 In accordance with CSRP DM CSRP-A-51-42-00-00A-720A-D and with reference to Figure 5 section K-K, install n°8 inserts P/N NAS1832C3-3 by means of EA934NA adhesive.
- 8.12 With reference to Figure 6 view B-B and Figure 7 section N-N and section M-M, perform n°4 holes \varnothing 11.48 ÷ 11.61 on the panel STA 1500.
- 8.13 In accordance with CSRP DM CSRP-A-51-42-00-00A-720A-D and with reference to Figure 6 view B-B and Figure 7 section N-N, install n°4 inserts P/N NAS1836C08-13 by means of EA934NA adhesive.
- 8.14 In accordance with CSRP DM CSRP-A-51-42-00-00A-720A-D and with reference to Figure 6 view B-B and Figure 7 section M-M, install n°2 inserts P/N NAS1836-08-08 by means of EA934NA adhesive.
- 8.15 With reference to Figure 6 view B-B and Figure 7 section N-N, prepare surface to assure correct electrical bonding and install n°2 brackets P/N AW001SB001A by means of n°4 washers P/N NAS1149DN832K and n°4 screws P/N NAS1802-08-5.
- 8.16 With reference to Figure 6 view B-B, remove the cover P/N 3P5315A05651 and retain existing hardware for later reuse.
- 8.17 With reference to Figure 6 view B-B, remove cover P/N 3P5315A06051 and retain existing hardware for later reuse.
- 8.18 With reference to Figure 6 detail L, fill with EA934NA adhesive the indicated existing insert.
- 8.19 With reference to Figure 6 detail L and Figure 7 section P-P, drill n°4 holes \varnothing 14.25 ÷ 14.38 on the panel STA 1500.

- 8.20 In accordance with CSRP DM CSRP-A-51-42-00-00A-720A-D and with reference to Figure 7 section P-P, install n°4 inserts P/N NAS1832C3-3 by means of EA934NA adhesive.
9. With reference to Figures 8 thru 14, perform the batteries start in parallel electrical installation P/N 3G2430A00411 as described in the following procedure:
 - 9.1 With reference to Figure 16 wiring diagram, remove the electrical connection of C/A B1B2 between sectioning connector P7 and K2 relay connector K2P1.
 - 9.2 With reference to Figure 17 wiring diagram, remove the electrical connection of C/A A1B3 between AUX BATTERY SHUNT and Ground stud GS2.
 - 9.3 With reference to Figure 17 wiring diagram, remove the electrical connection of C/A A1B8 between AUX BATTERY SHUNT, K2 relay and STBY battery BT2 connector BT2P2.
 - 9.4 With reference to Figure 9 view looking nose zone LH side, remove the existing bus bar.
 - 9.5 With reference to Figure 9 view looking nose zone LH side, move the existing power relay K1 and power relay K3 as shown.
 - 9.6 With reference to Figure 9 view looking nose zone LH side, install bus bar P/N 3G2460A02351 by means of n°2 washers P/N NAS1149D0632J, nut P/N MS21042L6 and bolt P/N AN6-6A.
 - 9.7 With reference to Figure 9 view looking nose zone LH side, install breaker P/N MS25244-35 on the previously installed bracket.
 - 9.8 In accordance with AMP DM 39-A-11-00-01-00A-720A-A and with reference to Figure 9 view looking nose zone LH side, install Decal P/N ED300CB455 in an area adjacent to previously installed breaker (CB455).
 - 9.9 With reference to Figure 9, at location n°1 install stud P/N A366A3E18C75 by means of EA9309.3NA adhesive.
 - 9.10 With reference to Figure 9, at locations n°2, 3 and 4 install n°3 studs P/N A366A3E10C by means of EA9309.3NA adhesive.
 - 9.11 With reference to Figure 10, at location n°5 install stud P/N A366A3E10C by means of EA9309.3NA adhesive.
 - 9.12 With reference to Figure 10 view looking nose zone RH side, install n°2 bus bars P/N 3G2460A00153 by means of n°4 washers P/N NAS1149D0632J, n°2 nuts P/N MS21042L6 and n°2 bolts P/N AN6-6A.
 - 9.13 With reference to Figure 11, at location n°6, replace the existing clipping with support P/N A366A3E22C, spacer NAS43DD3-40 and clamp P/N AW001CB02H.
 - 9.14 With reference to Figure 11, at location n°7 install support P/N AW001CL001-N6 by means of EA9309.3NA adhesive (C021).

- 9.15 With reference to Figure 11 View C, at location n°8, on existing hardware install clamp P/N MS21919WDG9.
- 9.16 With reference to Figure 11, install breaker P/N MS3320-5 on the previously installed bracket.
- 9.17 In accordance with AMP DM 39-A-11-00-01-00A-720A-A and with reference to Figure 11, install decal P/N ED300CB454 in an area adjacent to breaker.
- 9.18 With reference to Figure 11, remove the existing bus bar and install the bus bar P/N 3G2460A02251.

NOTE

With reference to the following step, it is allowed to install the screw P/N MS27039-1-04 and the washer P/N NAS1149DN332J instead of the screw P/N MS35206-227 and the washer P/N NAS1149DN616J.

- 9.19 In accordance with AMP DM 39-B-24-33-03-00A-720A-K and with reference to Figure 10, install power relay P/N 1152620-3 by means of n°2 screws P/N MS35206-227 and n°2 washers P/N NAS1149DN616J.
- 9.20 In accordance with AMP DM 39-A-11-00-01-00A-720A-A and with reference to Figure 10, install decal P/N ED300K310 in an area adjacent to previously installed relay (K310).
- 9.21 With reference to Figure 10 detail A, install bracket mount P/N M12883/53-101 by means of n°2 screws P/N MS24693-S47.
- 9.22 With reference to Figure 10 detail A, install relay P/N M83536/2-028M on the previously installed bracket.
- 9.23 In accordance with AMP DM 39-A-11-00-01-00A-720A-A and with reference to Figure 10 detail A, install decal P/N ED300K309 in an area adjacent to previously installed relay (K309).
- 9.24 With reference to Figure 10 detail A, install breaker P/N MS25244-35 on the previously installed bracket.
- 9.25 In accordance with AMP DM 39-A-11-00-01-00A-720A-A and with reference to Figure 10 detail A, install decal P/N ED300CB453 in an area adjacent to previously installed breaker (CB453).
- 9.26 With reference to Figure 14, at locations n°9, 10 and 11 remove the existing cable assemblies supports and reinstall supports in position as shown.
- 9.27 With reference to Figure 14 at locations n°12 and 13 install n°2 terminal studs P/N A363A01.

- 9.28 In accordance with AMP DM 39-A-11-00-01-00A-720A-A and with reference to Figure 14 view B-B, install decal P/N ED300GS84 in an area adjacent to terminal stud (GS84).
- 9.29 In accordance with AMP DM 39-A-11-00-01-00A-720A-A and with reference to Figure 14 view B-B, install decal P/N ED300GS85 in an area adjacent to terminal stud (GS85).
- 9.30 In accordance with AMP DM 39-A-24-34-01-00A-720A-K and with reference to Figure 14 view looking up roof, install DC-DC converter P/N RH40C (A449) by means of n°4 washers P/N NAS1149D0332J and n°4 screws P/N NAS1190E3P5AK.
- 9.31 In accordance with AMP DM 39-A-11-00-01-00A-720A-A and with reference to Figure 14 view looking up roof, install decal P/N ED300A449 in an area adjacent to previously installed DC-DC converter (A449).
- 9.32 In accordance with AMP DM 39-A-24-34-02-00A-720A-K and with reference to Figure 14 view looking up roof, install DC-DC converter P/N RH40C (A450) by means of n°4 washers P/N NAS1149D0332J and n°4 screws P/N NAS1190E3P5AK.
- 9.33 In accordance with AMP DM 39-A-11-00-01-00A-720A-A and with reference to Figure 14 view looking up roof, install decal P/N ED300A450 in an area adjacent to previously installed DC-DC converter (A450).
- 9.34 With reference to Figures 8 thru 14, lay down the following cable assembly following the existing route:
- 3G9A11A01901 batteries start in parallel C/A (A1A19);
 - 3G9A11B01501 batteries start in parallel C/A (A1B15);
 - 3G9A11B01601 batteries start in parallel C/A (A1B16);
 - 3G9A11B01701 batteries start in parallel C/A (A1B17);
 - 3G9A11B01801 batteries start in parallel C/A (A1B18);
 - 3G9A11B01901 batteries start in parallel C/A (A1B19);
 - 3G9B01A08001 batteries start in parallel C/A (B1A80);
 - 3G9B01A08101 batteries start in parallel C/A (B1A81);
 - 3G9B01B09801 batteries start in parallel C/A (B1B98);
 - 3G9B01B09901 batteries start in parallel C/A (B1B99).
- 9.35 With reference to Figures 9, 13, 14 and to Figure 15 wiring diagram, perform the electrical connection of C/A B1A81 between circuit breaker CB455 terminal lug CB455-1, circuit breaker panel DC-DC converter connector A449P1 and circuit breaker panel essential bus bar W31A.

- Protect the electrical connection with terminal lug CB455-1 by means of nipple P/N A584A02.
- 9.36 With reference to Figures 10 thru 14 and to Figure 15 wiring diagram, perform the electrical connection of cable assy B1B99 between circuit breaker CB453 terminal lug CB453-1, DC-DC converter connector A449P1, ground stud GS84, ground stud GS85, sectioning connector J62 and circuit breaker panel essential bus bar W32A. Protect the electrical connection with terminal lug CB453-1 by means of nipple A584A02.
- 9.37 With reference to Figure 9 and Figure 16 wiring diagram, perform the electrical connection of C/A A1A13 (which is supplied as part of A1A19) between circuit breaker CB455 terminal lug CB455-2 and relay K1 terminal lug K1-A2. Protect the electrical connection with terminal lugs CB455-2 and K1-A2 by means of n°2 nipples P/N A584A02.

NOTE

If necessary, it is allowed to install n°2 extra nipples
P/N A584A01 to protect electrical connections.

- 9.38 With reference to Figures 9, 10 and to Figure 16 wiring diagram perform the electrical connection of C/A A1B12 (which is supplied as part of C/A A1B15) between relay K1 terminal lug K1-A1 and relay K310 terminal lug K310-A2. Protect the electrical connection with terminal lug K1-A1 and terminal lug K310-A2 by means of n°2 nipples P/N A584A01.
- 9.39 With reference to Figures 10 thru 14 and to Figures 16 and 17 wiring diagrams, perform the electrical connection of C/A B1B98 between relay K310 connector K310 P1, splice SP2021, diode CR86, sectioning connector P7, sectioning connector P62, relay K2 connector K2P1, CB454 terminal lug CB454-1, CB454 terminal lug CB454-2, relay K2 terminal lug K2-A2, relay K309 socket K309P1, terminal board TB20 connector TB20P1 and terminal board TB8 connector TB8P1. Protect terminal lugs CB454-1 and CB454-2 by means of n°2 nipples P/N A584A02.

NOTE

If necessary, it is allowed to install n°2 extra nipples
P/N A584A05 to protect electrical connections.

- 9.40 With reference to Figures 10, 11 and to Figure 16 wiring diagram, perform the electrical connection of C/A A1B11 (which is supplied as part of C/A A1B16) between relay K310 terminal lug K310-A1 and relay K2 terminal lug K2-A1. Protect terminal lugs K310-A1 and K2-A1 by means of n°2 nipples P/N A584A05.

Use bolt P/N AN6-7A, n°2 washers P/N NAS1149D0632J, nut P/N MS21042L6 for the electrical connection between terminal lug K2-A1 and bus bar.

- 9.41 With reference to Figures Figures 10, 11 and to Figure 16 wiring diagram, perform the electrical connection of C/A A1B13 (which is supplied as part of A1B17) between circuit breaker CB453 terminal lug CB453-2 and relay K2 terminal lug K2-A2. Protect the electrical connection with terminal lugs CB453-2 and K2-A2 by means of n°2 nipples P/N A584A02.
- 9.42 With reference to Figures 11, 12 and to Figure 17 wiring diagram, perform the electrical connection of C/A A1B15 (which is supplied as part of A1B18) between relay K2 terminal lug K2-A1, auxiliary battery BT2 connector BT2P2 and AUX BATT SHUNT terminal lug R4-1. Protect the electrical connection with terminal lug K2-A1 by means of nipple P/N A584A01.

NOTE

It is allowed to replace the existing bolt with the P/N AN6-10A.

- 9.43 With reference to Figure 12 and to Figure 17 wiring diagram, perform the electrical connection of C/A A1B14 (which is supplied as part of A1B19) between AUX BATT SHUNT terminal lug R4-2 and ground stud point GS2.
- 9.44 With reference to Figures 9 and to Figure 17 wiring diagram, perform the electrical connection of C/A B1A80 between sectioning connector J7 and relay K85 connector K85P1.
- 9.45 Perform a pin-to-pin continuity check of all the electrical connections made.
- 9.46 With reference to Figure 6 view B-B, install cover P/N 3G5315A17851 by means of previously removed hardware.
- 9.47 With reference to Figure 6 detail L, prepare the indicated surfaces to assure correct electrical bonding and install cover P/N 3G5315A17951 by means of previously removed hardware.
- 9.48 With reference to Figure 9 view looking nose zone LH side and Figure 11 view looking nose zone RH side, install n°2 bundle spacer P/N A631A01A.

NOTE

Perform the following step if the helicopter was equipped with auxiliary battery 13 Ah.

10. In accordance with Service Bulletin SB139-045, install the auxiliary battery 27Ah.

NOTE

Perform the following step if the helicopter was already equipped with auxiliary battery 27 Ah.

11. In accordance with AMP DM 39-D-24-32-02-00A-720A-K, re-install the auxiliary battery 27 Ah.
12. In accordance with AMP DM 39-D-24-32-02-02A-320A-K, if not already accomplished, perform the auxiliary battery 27 Ah temperature sensor operational check.

NOTE

Perform the following step if the helicopter was equipped with main battery 44 Ah 19 cells.

13. In accordance with Service Bulletin SB139-247, perform the main battery conversion from 19 cells to 20 cells.

NOTE

Perform the following step if the helicopter was equipped with main battery 40 Ah or with main battery 44 Ah 20 cells.

14. In accordance with AMP DM 39-C-24-32-01-00A-720A-K, install the main battery 44 Ah P/N 33204-002.
15. In accordance with AMP DM 39-C-24-32-01-02A-320A-K, if not already accomplished, perform the main battery temperature sensor operational check.
16. In accordance with AMP DM 39-A-24-32-00-00A-320C-A, if not already accomplished, perform the battery power generation system operational check.
17. In accordance with AMP DM 39-A-06-41-00-00A-010A-A, install access panels 131AL, 132AR, 141DL, 142ER, 142CR, 160AT and 160BT and close access door 213AL.
18. In accordance with AMP DM 39-A-25-82-03-00A-720A-A, install the left hinged lining panel.
19. In accordance with AMP DM 39-A-25-82-04-00A-720A-A, install the right hinged lining panel.
20. In accordance with weight and balance changes, update the Chart A (see Rotorcraft Flight Manual, Part II, section 6).
21. Return the helicopter to flight configuration and record for compliance with Part I of this Service Bulletin on the helicopter logbook.
22. Send the attached compliance form to the following mail box:

engineering.support.lhd@leonardocompany.com

As an alternative, gain access to My Communications section on Leonardo WebPortal and compile the "Service Bulletin Application Communication".

PART II

1. In accordance with AMP DM 39-A-00-20-00-00A-120A-A, prepare the helicopter on ground for a safe maintenance. Disconnect the battery, all electrical power sources and/or the external power supply.
2. In accordance with AMP DM 39-A-06-41-00-00A-010A-A, remove access panels 131AL, 132AR, 141DL, 142ER, 142CR, 160AT and 160BT and open access door 213AL.
3. In accordance with AMP DM 39-A-25-82-03-00A-520A-A, remove the left hinged lining panel.
4. In accordance with AMP DM 39-A-25-82-04-00A-520A-A, remove the right hinged lining panel.
5. In accordance with helicopter configuration and with AMP DM 39-A-24-32-01-00A-520A-A or DM 39-B-24-32-01-00A-520A-K or DM 39-C-24-32-01-00A-520A-K, remove the main battery 40 Ah or 44 Ah 19 cells or 44 ah 20 cells.
6. In accordance with helicopter configuration and with AMP DM 39-A-24-32-02-00A-520A-A or DM 39-D-24-32-02-00A-520A-K, remove the auxiliary battery 13 Ah or 27 Ah.
7. With reference to Figures 19 thru 22, gain access to the area affected by the installation and perform the battery start in parallel structural provision P/N 3G5310A89613 as described in the following procedure:
 - 7.1 With reference to Figure 19 detail D and section E-E, perform n°2 holes $\varnothing 11.48 \div 11.61$ and n°2 holes $\varnothing 4.90 \div 5.03$.
 - 7.2 In accordance with CSRP DM CSRP-A-51-42-00-00A-720A-D and with reference to Figure 19 detail D and section E-E, install n°2 inserts P/N NAS1836-3-09 by means of EA934NA adhesive.
 - 7.3 With reference to Figure 19 detail D and section E-E, install n°2 nut plates P/N MS21071L3 by means of n°4 rivets P/N MS20426AD3.
 - 7.4 With reference to Figure 19 section E-E, install bracket P/N A419A004A1A by means of n°2 screws P/N NAS1802-3-4, n°2 screws P/N NAS1802-3-8 and n°4 washers P/N NAS1149D0332K.
 - 7.5 With reference to Figure 19 section J-J, drill n° 2 holes $\varnothing 11.48 \div 11.61$ on right vertical panel.
 - 7.6 In accordance with CSRP DM CSRP-A-51-42-00-00A-720A-D and with reference to Figure 19 section J-J, install n°2 inserts P/N NAS1836-08-08 by means of EA934NA adhesive.
 - 7.7 With reference to Figure 19 view H-H and section J-J, install bracket P/N AW001SB001A by means of n°2 screws P/N NAS1802-08-4 and n°2 washers P/N NAS1149DN832K.

- 7.8 With reference to Figure 20 section L-L, drill hole at \varnothing 32.00 and install grommet P/N MS35489-15.
- 7.9 With reference to Figure 20 detail M, remove cover P/N 3G5315A29251 and install cover P/N 3G5315A29252 on existing inserts by means of n°2 screws P/N NAS1802-06-5 and n°2 washers P/N NAS1149DN532K.
- 7.10 With reference to Figure 20 section F-F, drill n°2 holes \varnothing 5.16 ÷ 5.28 thru upper skin and enlarge up to \varnothing 9.50 ÷ 9.60 the honeycomb core and lower skin.
- 7.11 In accordance with CSRP DM CSRP-A-51-42-00-00A-720A-D and with reference to Figure 20 section F-F, install n°2 inserts P/N 999-5000-3-106 by means of EA934NA adhesive.
- 7.12 With reference to Figure 20 section F-F, install bracket assy P/N 3G5316A97031 by means of n°2 screws P/N NAS1802-3-5 and n°2 washers P/N NAS1149D0332K.
- 7.13 With reference to Figure 20 section F-F, install cover P/N 3G5316A97151 by means of n°2 crews P/N NAS1802-08-8 and n°2 washers P/N NAS1149DN832K.
- 7.14 With reference to Figure 20 section P-P, drill hole \varnothing 14.25 ÷ 14.38.
- 7.15 In accordance with CSRP DM CSRP-A-51-42-00-00A-720A-D and with reference to Figure 16 section P-P, install insert P/N NAS1832C3-3 by means of EA934NA adhesive.
- 7.16 With reference to Figure 20 section N-N, drill n°2 holes \varnothing 11.48÷11.61.
- 7.17 In accordance with CSRP DM CSRP-A-51-42-00-00A-720A-D and with reference to Figure 16 section N-N, install inserts P/N NAS1836C08-13 by means of EA934NA adhesive.
- 7.18 With reference to Figure 20 section N-N, install bracket P/N AW001SB001A by means of n°2 screws P/N NAS1802-08-5 and n°2 washers P/N NAS1149DN832K.
- 7.19 Repeat steps 7.16 thru 7.18 on RH side.
- 7.20 With reference to Figure 21 section R-R and section S-S, drill n°8 holes \varnothing 14.25÷14.38.
- 7.21 In accordance with CSRP DM CSRP-A-51-42-00-00A-720A-D and with reference to Figure 21 section R-R and section S-S, install n°8 inserts P/N NAS1832C3-3 by means of EA934NA adhesive.
- 7.22 With reference to Figure 21 section S-S, install bracket assy P/N 3G5316A97231 by means of n°4 screws P/N NAS1802-3-5 and n°4 washers P/N NAS1149D0332K.
- 7.23 With reference to Figure 22 detail G, remove n°2 tie rods with fitting P/N A468A001A. Retain parts and existing hardware for later reuse.

- 7.24 With reference to Figure 22 detail G, remove phenolic strip P/N A467A150A116, support P/N A466A222A116 and n°2 screws P/N MS24694-S47.
- 7.25 With reference to Figure 22 detail G, remove phenolic strip P/N A467A200A116 and n°2 screws P/N MS24694-S47.
- 7.26 With reference to Figure 22 detail G, remove angle battery assy P/N 3G5315A24631.
- 7.27 With reference to Figure 22 detail G, fill the holes of panel battery by means of EA934NA adhesive.
- 7.28 With reference to Figure 22 section U-U, drill n°4 holes Ø5.16÷5.28 through upper skin and enlarge up to Ø9.50÷9.60 through honeycomb core and lower skin.
- 7.29 With reference to Figure 22 section U-U, install n°4 inserts P/N 999-5000-3-106 by means of EA934NA adhesive.
- 7.30 With reference to Figure 22 section V-V and section AA-AA, drill n°8 holes Ø5.16÷5.28 through upper skin and enlarge up to Ø9.50÷9.60 through honeycomb core and lower skin.
- 7.31 With reference to Figure 22 section V-V, install n°8 inserts P/N 999-5000-3-106 by means of EA934NA adhesive.
- 7.32 With reference to Figure 22 section VV, install n°2 support P/N A466A222A180 and n°2 phenolic strip by means of n°6 screws P/N MS24694-S47.
- 7.33 With reference to Figure 22 section AA-AA, install phenolic strip P/N A467A200A180 by means of n°3 screws P/N MS24694-S47.
- 7.34 With reference to Figure 22 section U-U, replace the n°2 tie rods P/N A469A001A165 with n°2 tie rods P/N A469A001A205 by means of previously removed hardware.
- 7.35 With reference to Figure 22 detail G and detail W, install in the new positions n°2 tie rods with fittings P/N A468A001A by means of previously removed hardware.

NOTE

Perform the following step 8 only if 2nd transponder electrical provision P/N 3G3450A01713 is required.

- 8. With reference to Figure 23 perform the batteries start in parallel structural variant P/N 3G5310P01011 as described in the following procedure:
 - 8.1 With reference to Figure 23 view AB-AB, remove bracket P/N A419A004A1A and existing screws and washers. Plug the existing insert hole with screw P/N NAS1802-3-4 and washer P/N NAS1149D0316K.

- 8.2 With reference to Figure 23, remove bracket assy P/N 3G5316A97031 and existing screws and washers. Plug the existing inserts with screws P/N NAS1802-3-4 and washer P/N NAS1149D0316K.
- 8.3 With reference to Figure 23 view AC-AC, install bracket assy P/N 3G5316A97032 by means of n°2 screws P/N NAS1802-3-6 and n°2 washers P/N NAS1149D0316K.
- 8.4 With reference to Figure 23 section AC-AC, install cover P/N 3G5316A97151 on bracket assy P/N 3G5316A97032 by means of n°2 screws P/N NAS1802-08-8 and n°2 washers P/N NAS1149DN832K.
9. With reference to Figure 18 and Figure 24 thru 30 perform the batteries start in parallel electrical installation P/N 3G2430A00413 as described in the following procedure:
 - 9.1 With reference to Figure 24, at location n°1 install stud P/N A366A3E18C75 by means of EA9309.3NA Adhesive (C021) and clamp P/N AW001CB08H by means of spacer P/N NAS43DD3-37N, washer P/N NAS1149D0332J and nut P/N MS21043-3.
 - 9.2 With reference to Figure 24, at location n°2 install stud P/N A366A3E08C75 by means of EA9309.3NA Adhesive (C021) and clamp P/N AW001CB08H by means of washer P/N NAS1149D0332J and nut P/N MS21043-3.
 - 9.3 With reference to Figure 24, at location n°3 install stud P/N A366A3E16C75 by means of EA9309.3NA Adhesive (C021) and clamp P/N AW001CB08H by means of spacer P/N NAS43DD3-34N, washer P/N NAS1149D0332J and nut P/N MS21043-3.
 - 9.4 With reference to Figure 24, install circuit breaker P/N MS25244-35 on bracket P/N AW001SB001A.
 - 9.5 In accordance with AMP DM 39-A-11-00-01-00A-720A-A and with reference to Figure 24, install decal P/N ED300CB455 in an area adjacent to CB455.
 - 9.6 With reference to Figure 26 view A, remove existing bus bar and install bus bar P/N 3G2460A02351, n°2 washers P/N NAS1149D0632J, bolt P/N AN6-6A and nut P/N MS21042L6.
 - 9.7 With reference to Figure 24 view looking nose zone LH side, move cable assy A1A3 as shown.
 - 9.8 With reference to Figure 25, at locations n°4 and 5 install n°2 studs P/N A366A3E16C75 by means of EA9309.3NA Adhesive (C021) and n°2 clamps P/N AW001CB08H by means of n°2 spacers P/N NAS43DD3-34N, n°2 washers P/N NAS1149D0332J and n°2 nuts P/N MS21043-3.

- 9.9 With reference to Figure 25, at locations n°6 and 7 remove existing screws and install on existing hardware n°2 clamps P/N AW001CB08H by means of n°2 screws P/N NAS1802-3-9.
- 9.10 With reference to Figure 25, at location n°8 install bracket P/N MS9592-214, clamp P/N AW001CB10H and clamp P/N AW001CB12H by means of screw P/N MS27039-1-10, screw P/N NAS1802-3-10, n°2 washers P/N NAS1149D0332J and nut P/N MS21042L3.
- 9.11 In accordance with AMP DM 39-B-24-33-03-00A-720A-K and with reference to Figure 25, install power relay P/N 1152620-3 by means of n°2 washers P/N NAS1149D0332J and n°2 screws P/N NAS1802-3-5.
- 9.12 In accordance with AMP DM 39-A-11-00-01-00A-720A-A and with reference to Figure 25, install decal P/N ED300K310 in an area adjacent to power relay.
- 9.13 With reference to Figure 25, install circuit breaker P/N MS3320-5 on bracket P/N AW001SB001A.
- 9.14 In accordance with AMP DM 39-A-11-00-01-00A-720A-A and with reference to Figure 25, install decal P/N ED300CB454 in an area adjacent to CB454
- 9.15 With reference to Figure 26 view A, remove existing bus bar and install bus bar P/N 3G2460A02251.
- 9.16 With reference to Figure 26 view A, at location n°9 remove existing stud and install stud P/N A366A3E10C75 and clamp P/N AW001CB10H by means of existing hardware.
- 9.17 With reference to Figure 26 view A, remove existing screw and install clamp P/N AW001CB12H by means of spacer P/N NAS43DD3-60N and screw P/N NAS1802-3-24.
- 9.18 With reference to Figure 26 view B1, at locations n°11 and 12 remove existing screws and replace existing clamp and grommet by means of n°2 screws P/N NAS1802-3-12.
- 9.19 With reference to Figure 26 view B, at location n°13 install support P/N AW001CL001-N6 by means of EA9309.3NA Adhesive (C021).
- 9.20 With reference to Figure 26 view B, install breaker P/N MS25244-35.
- 9.21 In accordance with AMP DM 39-A-11-00-01-00A-720A-A and with reference to Figure x, install decal P/N ED300CB453 in an area adjacent to CB453.
- 9.22 With reference to Figure 26 view B, install relay P/N M83536/2-028M on relay socket K309P1.
- 9.23 In accordance with AMP DM 39-A-11-00-01-00A-720A-A and with reference to Figure 26 view B, install decal P/N ED300K309 in and area adjacent to relay K309.

- 9.24 With reference to Figure 27 view E, at location n°14 install support P/N AW001CL002A-X1 by means of EA9309.3NA Adhesive (C021).
- 9.25 With reference to Figure 30, at location n°15 install support P/N AW001TL3A08 by means of EA9309.3NA Adhesive (C021) and clamp P/N AW001CB05H by means of washer P/N NAS1149D0332J and screw P/N NAS1801-3-8.
- 9.26 With reference to Figure 30, at location n°16 install standoff P/N A388A3E18C75 by means of EA9309.3NA Adhesive (C021) and clamp P/N AW001CB03H by means of washer P/N NAS1149D0332J and screw P/N NAS1190E3P5AK.
- 9.27 With reference to Figure 30 at location n°17 install support P/N AW001CL509-N6 by means of EA9309.3NA Adhesive (C021).
- 9.28 With reference to Figure 30, at locations n°18 and 19 install n°2 studs P/N A366A3E22C75 by means of EA9309.3NA Adhesive (C021) and n°2 clamps P/N AW001CB03H by means of n°2 spacers P/N NAS43DD3-52, n°2 washers P/N NAS1149D0332J and n°2 nuts P/N MS21043-3.
- 9.29 With reference to Figure 30, at locations n°20 and 21, install n°2 terminal studs P/N A363A01.
- 9.30 In accordance with AMP DM 39-A-11-00-01-00A-720A-A and with reference to Figure 30 view D-D, install decal P/N ED300GS2023 and P/N ED300GS2021 in an area adjacent to GS2023 and GS2021.
- 9.31 With reference to Figure 30 view D-D, install n°2 DC-DC converter P/N RH40C by means of n°4 screws P/N MS27039-1-05, n°4 screws P/N MS27039-1-07 and n°8 washers P/N NAS1149D0332J.
- 9.32 In accordance with AMP DM 39-A-11-00-01-00A-720A-A and with reference to Figure 30 view D-D, install decal P/N ED300A450 and P/N ED300A449 in an area adjacent to DC-DC converters A450 and A449.
- 9.33 With reference to Figure 32 wiring diagram, remove the electrical connections of cable assy A1B208 between sectioning connector P103 and Ke relay connector K2P1.
- 9.34 With reference to Figure 33 wiring diagram, remove the electrical connections of cable assy A1B205 between K2 relay and auxiliary battery connector BT2P2.
- 9.35 With reference to Figure 33 wiring diagram, remove the electrical connections of cable assy A1B209 between auxiliary battery shunt R110 and ground point GS102.
- 9.36 With reference to Figures 24 thru 30, lay down the following cable assemblies following existing route unless otherwise indicated on the figures:
- ✓ 3G9A01A51801 batteries start in parallel C/A (A1A518);
 - ✓ 3G9A01B48001 batteries start in parallel C/A (A1B480);
 - ✓ 3G9A11A01811 batteries start in parallel C/A (A1A18);

- ✓ 3G9A11A01911 batteries start in parallel C/A (A1A19);
 - ✓ 3G9A11B01111 batteries start in parallel C/A (A1B11);
 - ✓ 3G9A11B01211 batteries start in parallel C/A (A1B12);
 - ✓ 3G9A11B01311 batteries start in parallel C/A (A1B13);
 - ✓ 3G9A11B01411 batteries start in parallel C/A (A1B14);
 - ✓ 3G9B01A89101 batteries start in parallel C/A (B1A891);
 - ✓ 3G9B01B76501 batteries start in parallel C/A (B1B765).
- 9.37 With reference to Figure 24 view looking nose LH side and Figure 32 wiring diagram, perform the electrical connection of cable assy A1A516 (which is supplied as part of A1A19) between circuit breaker CB455 terminal lug CB455-2 and power relay K1 terminal lug K1-A2. Protect the electrical connection with terminal lug by means of n°2 nipples P/N A584A02.
- 9.38 With reference to Figures 24, 28, 29, 30 and Figure 31 wiring diagram, perform the electrical connection of cable assy B1A891 between CB455, DC-DC converter connector A449P1, GS2021 and circuit braker panel essential bus bar W31A.
- 9.39 With reference to Figures 24, 25 and to Figure 32 wiring diagram, perform the electrical connection of cable assy A1A517 (which is supplied as part of A1A18) between power relay K1 terminal lug K1-A1 and power relay K310 terminal lug K310-A2. Protect the electrical connection with terminal lug by means of n°2 nipples P/N A584A01.
- 9.40 With reference to Figures 24 and Figure 33 wiring diagram, perform the electrical connection of cable assy A1A518 between sectioning connector J103 and relay socket K85 connector K85P1.
- 9.41 With reference to Figures 25 thru 27 and to Figures 32 and 33 wiring diagram, perform the electrical connection of cable assy A1B480 between terminal board TB114, sectioning connector P103, circuit breaker CB454, power relay K310 connector K310P1, relay socket K309P1 relay K2 connector K2P1 and relay K2 terminal lug K2-A2. Protect electrical connection with terminal lug by means of nipple A584A02.
- 9.42 With reference to Figures 25 thru 27 and to Figure 33 wiring diagram, perform the electrical connection of cable assy A1B482 (which is supplied as part of A1B13) between auxiliary battery connector BT2P2, relay K2 terminal lug K2-A1 and auxiliary battery shunt R110 terminal lug R110-1.
- 9.43 With reference to Figure 27 view C and Figure 33 wiring diagram, perform the electrical connection of cable assy A1B483 (which is supplied as part of A1B14) between ground point GS102 and auxiliary battery shunt R110 terminal lug R110-2. Use bolt P/N AN6-7A for the electrical connection with ground point GS102.

- 9.44 With reference to Figures 25 thru 30 and to Figure 31 wiring diagram, perform the electrical connection of cable assy B1B765 between circuit breaker CB453 terminal lug CB453-1, DC-DC converter connector A450P1, ground stud GS2023 and sectioning connector J114. Protect the electrical connection with terminal lug CB453-1 by means of nipple A584A02.
- 9.45 With reference to Figure 26 and Figure 32 wiring diagram, perform the electrical connection of cable assy B1B484 (which is supplied as part of A1B12) between power relay K310 terminal lug K310-A1 and relay K2 terminal lug K2-A1. Use existing hardware and n°2 nipples P/N A584A01 to protect the terminal lugs.
- 9.46 With reference to Figures 25, 26 and Figure 32 wiring diagram, perform the electrical connection of cable assy B1B481 (which is supplied as part of A1B11) between relay K2 terminal lug K2-A2 and circuit breaker CB453 terminal lug CB453-2. Protect the electrical connection with terminal lug CB453-2 by means of nipple P/N A584A02.
- 9.47 Perform a pin-to-pin continuity check of all the electrical connections made.

NOTE

Perform the following step 10 if the helicopter was equipped with auxiliary battery 13 Ah.

10. In accordance with Service Bulletin SB139-138, install the auxiliary battery 27 Ah.

NOTE

Perform the following step 11 if the helicopter was already equipped with auxiliary battery 27 Ah.

11. In accordance with AMP DM 39-D-24-32-02-00A-720A-K, re-install the auxiliary battery 27 Ah.
12. In accordance with AMP DM 39-D-24-32-02-02A-320A-K, if not already accomplished, perform the auxiliary battery 27 Ah temperature sensor operational check.

NOTE

Perform the following step 13 only if the helicopter was equipped with main battery 44 Ah 19 cell.

13. In accordance with Service Bulletin SB139-247, perform the main battery conversion from 19 cells to 20 cells.

NOTE

Perform the following step 14 if the helicopter was equipped with main battery 40 Ah or with main battery 44 Ah 20 cells.

14. In accordance with AMP DM 39-C-24-32-01-00A-720A-K, install the main battery 44 Ah P/N 33204-002.
15. In accordance with AMP DM 39-C-24-32-01-02A-320A-K, if not already accomplished, perform the main battery temperature sensor operational check.
16. In accordance with AMP DM 39-A-06-41-00-00A-010A-A, install access panels 131AL, 132AR, 141DL, 142ER, 142CR, 160AT and 160BT and Close access door 213AL.
17. In accordance with AMP DM 39-A-25-82-03-00A-720A-A, install the left hinged lining panel.
18. In accordance with AMP DM 39-A-25-82-04-00A-720A-A, install the right hinged lining panel.
19. In accordance with weight and balance changes, update the Chart A (see Rotorcraft Flight Manual, Part II, section 6).
20. Return the helicopter to flight configuration and record for compliance with Part II of this Service Bulletin on the helicopter logbook.
21. Send the attached compliance form to the following mail box:

engineering.support.lhd@leonardocompany.com

As an alternative, gain access to My Communications section on Leonardo WebPortal and compile the "Service Bulletin Application Communication".

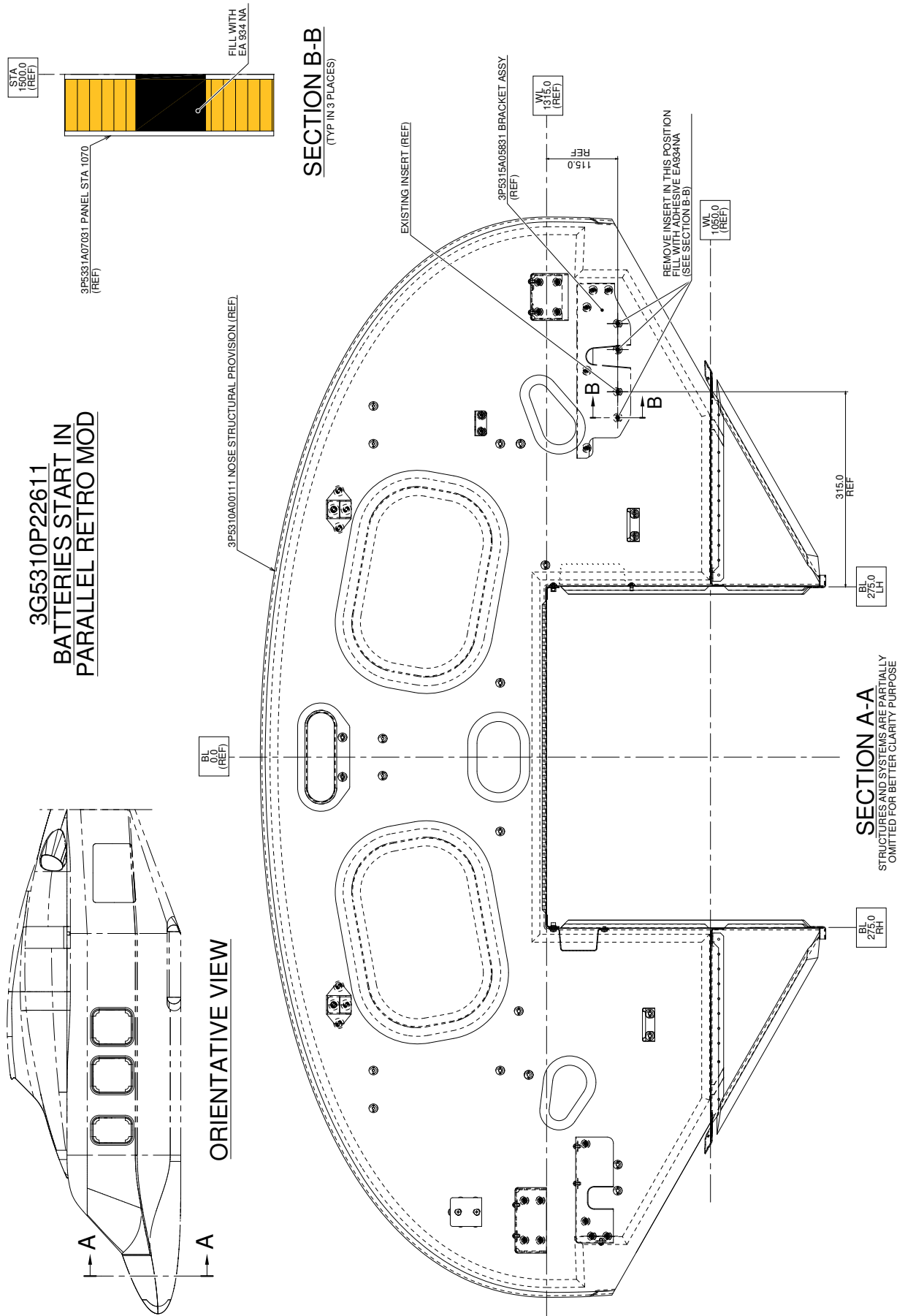

Figure 1

3G5310A89611
BATTERIES START IN PARALLEL
STRUCTURAL PROVISION

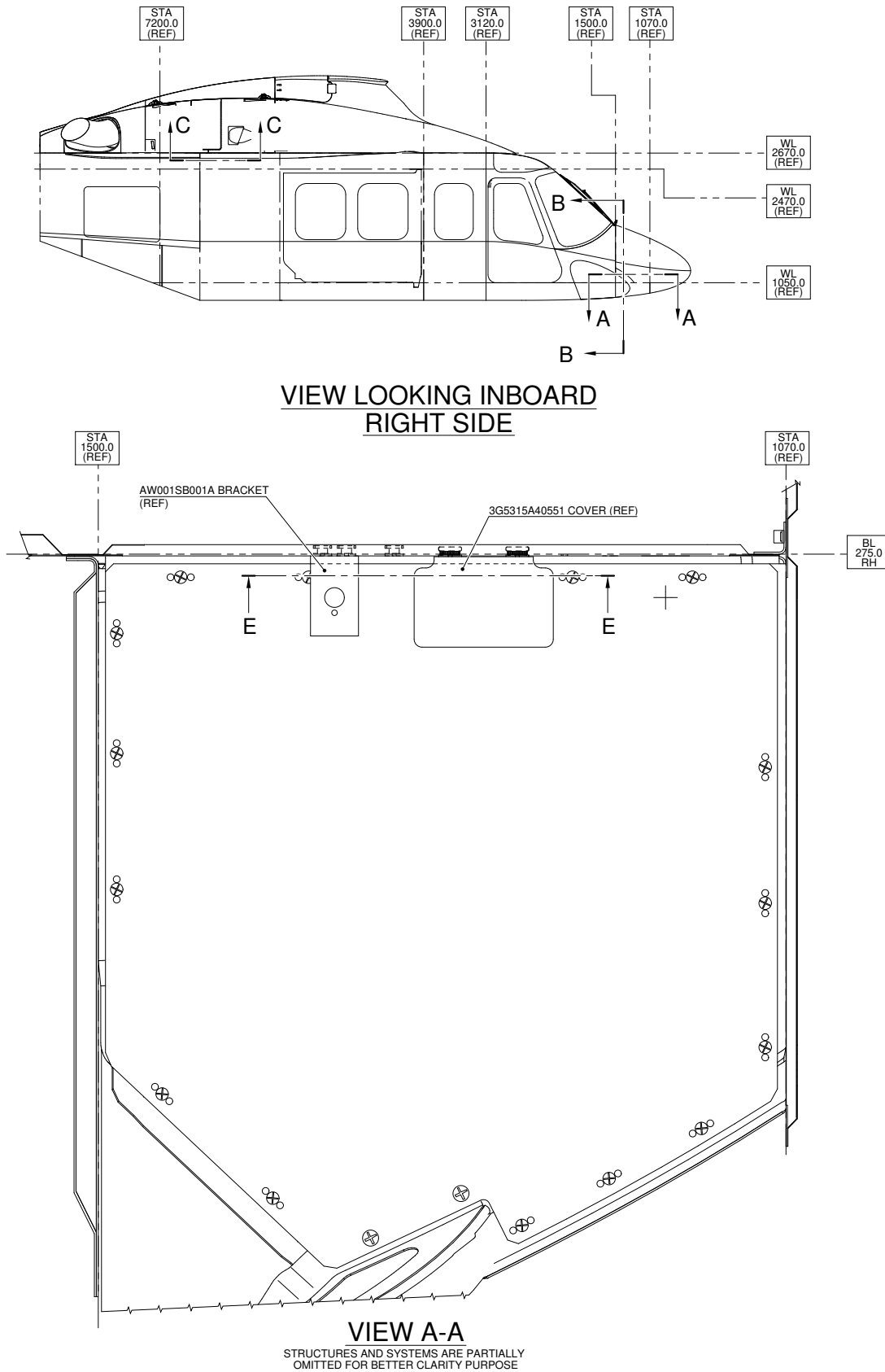
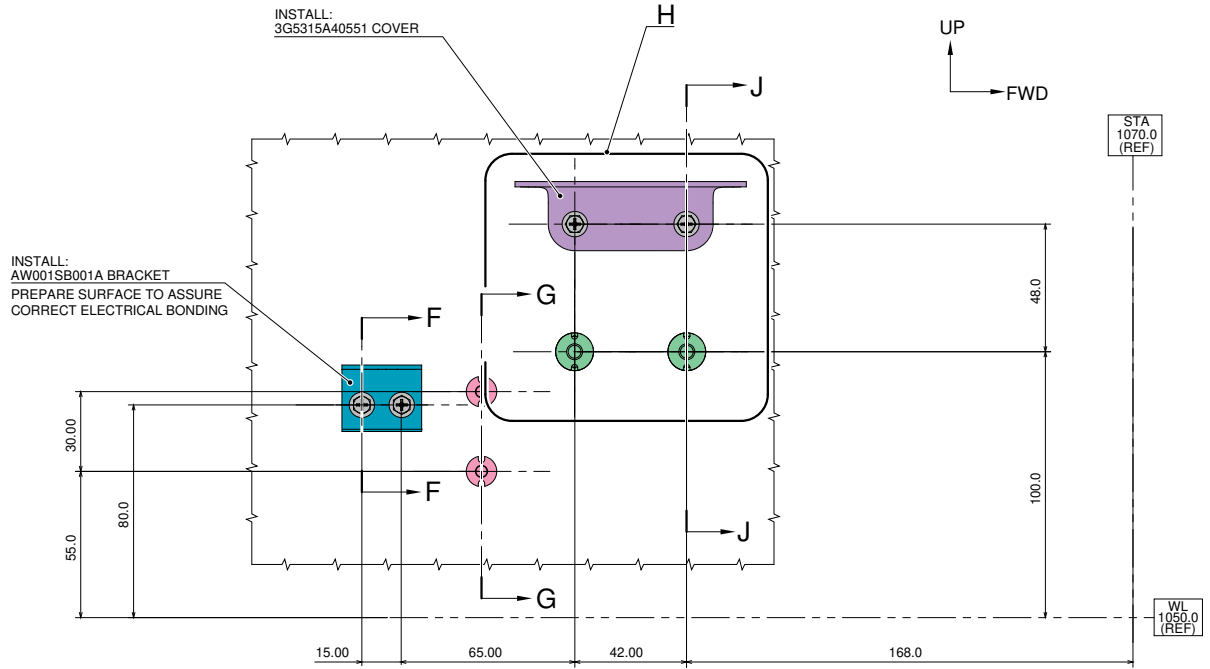

Figure 2



VIEW E-E

STRUCTURES AND SYSTEMS ARE PARTIALLY OMITTED FOR BETTER CLARITY PURPOSE

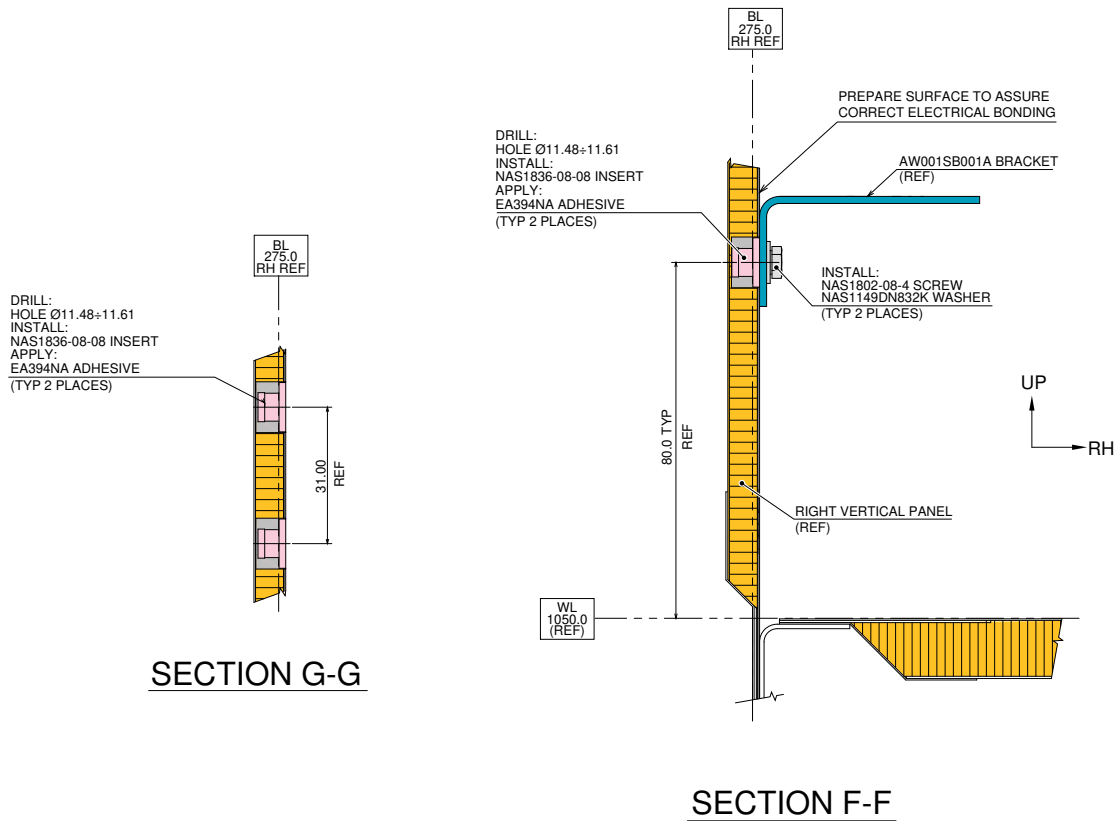
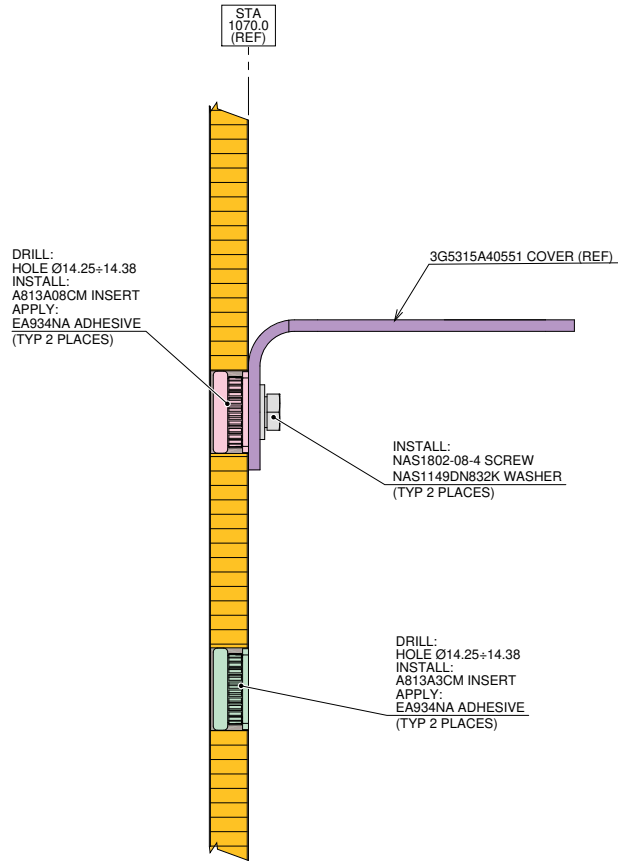
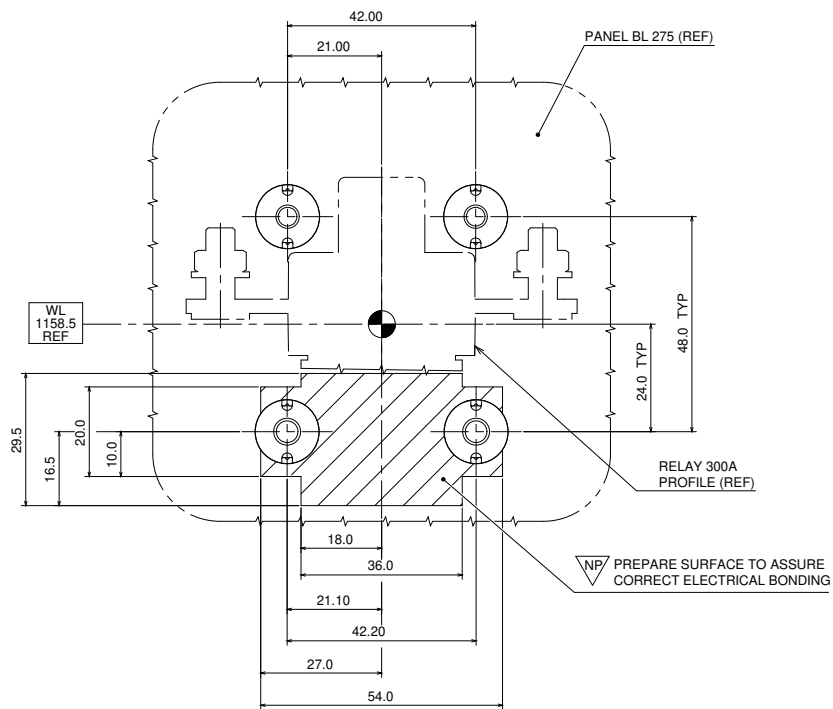

Figure 3



SECTION J-J



DETAIL H

3G5315A40551 AND FASTENERS OMITTED FOR CLARITY

Figure 4

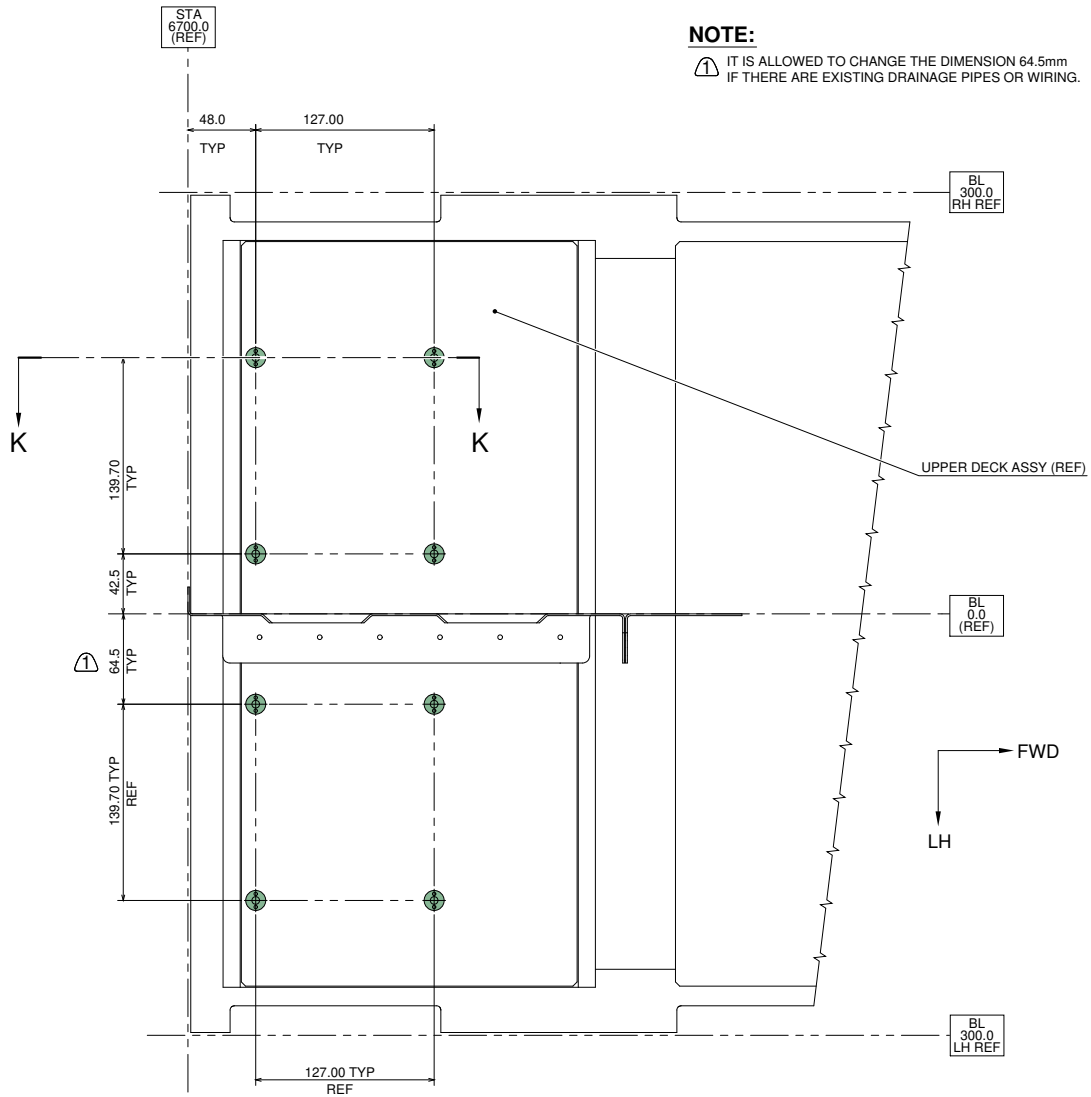

VIEW C-C
STRUCTURES AND SYSTEMS ARE PARTIALLY OMITTED FOR BETTER CLARITY PURPOSE

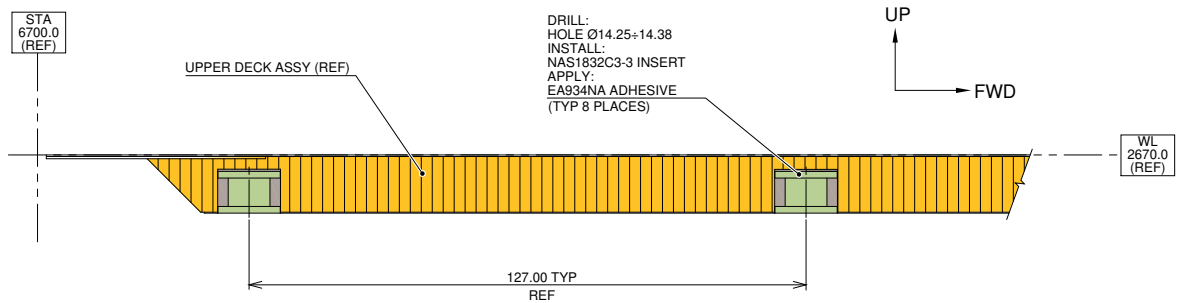

SECTION K-K

Figure 5

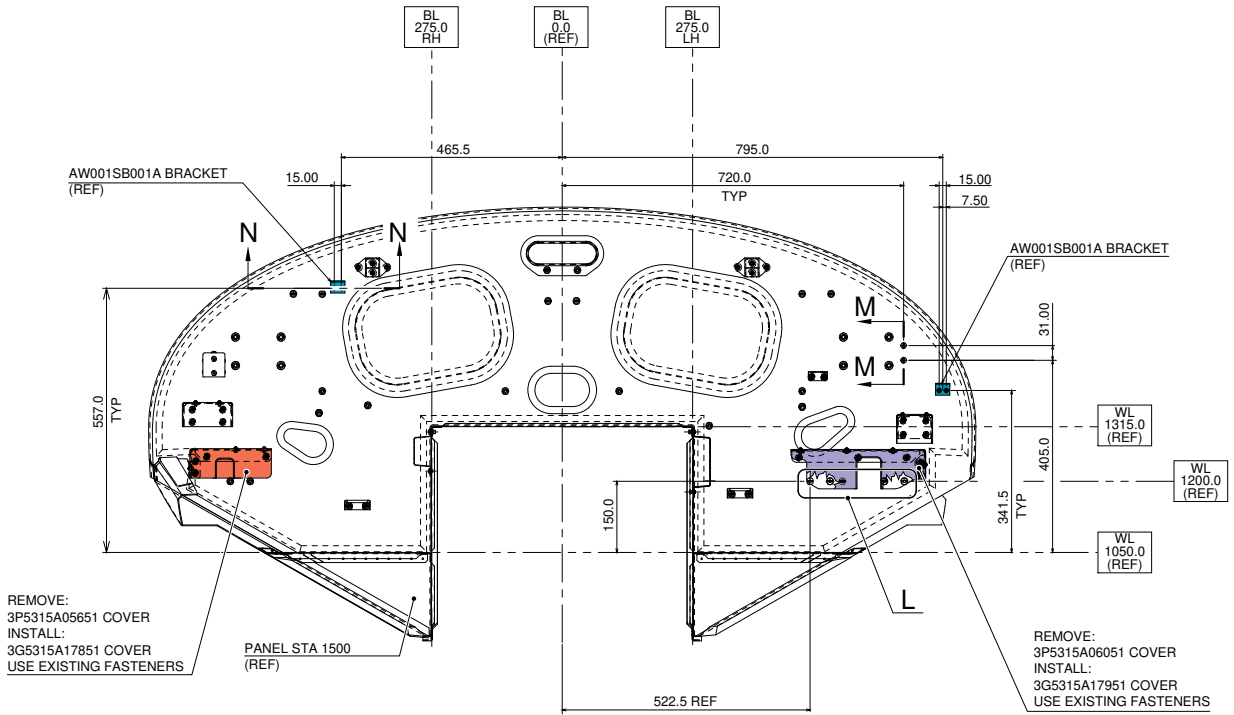

VIEW B-B

STRUCTURES AND SYSTEMS ARE PARTIALLY OMITTED FOR BETTER CLARITY PURPOSE

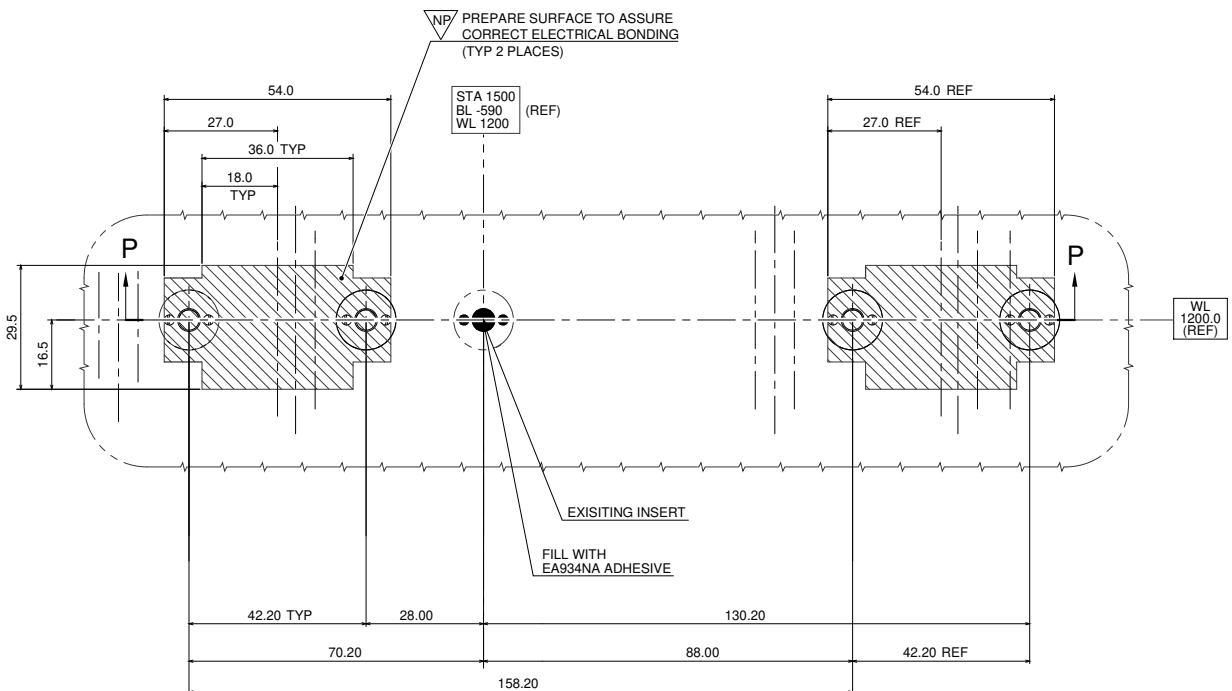

DETAIL L

Figure 6

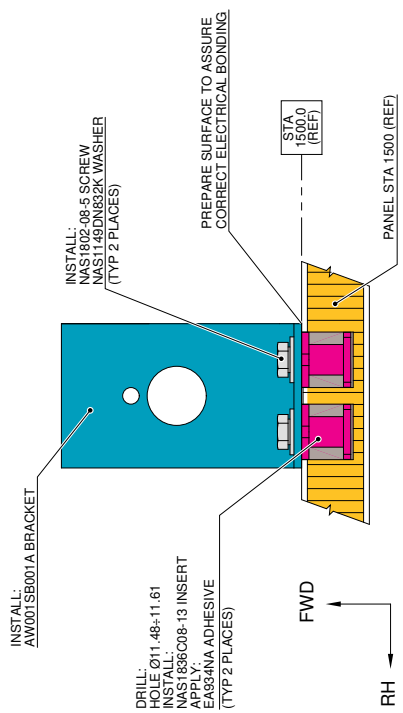
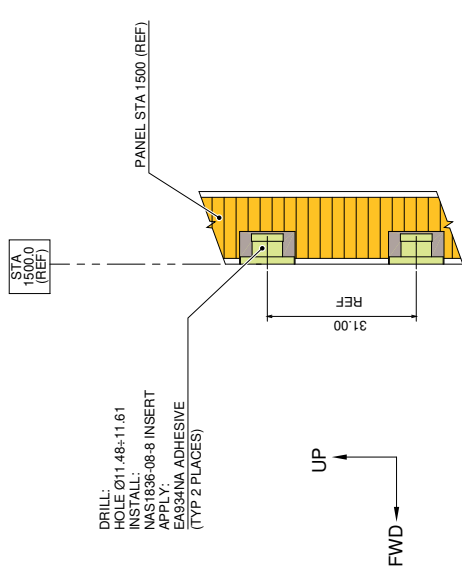

SECTION N-N
(TYP 2 PLACES)

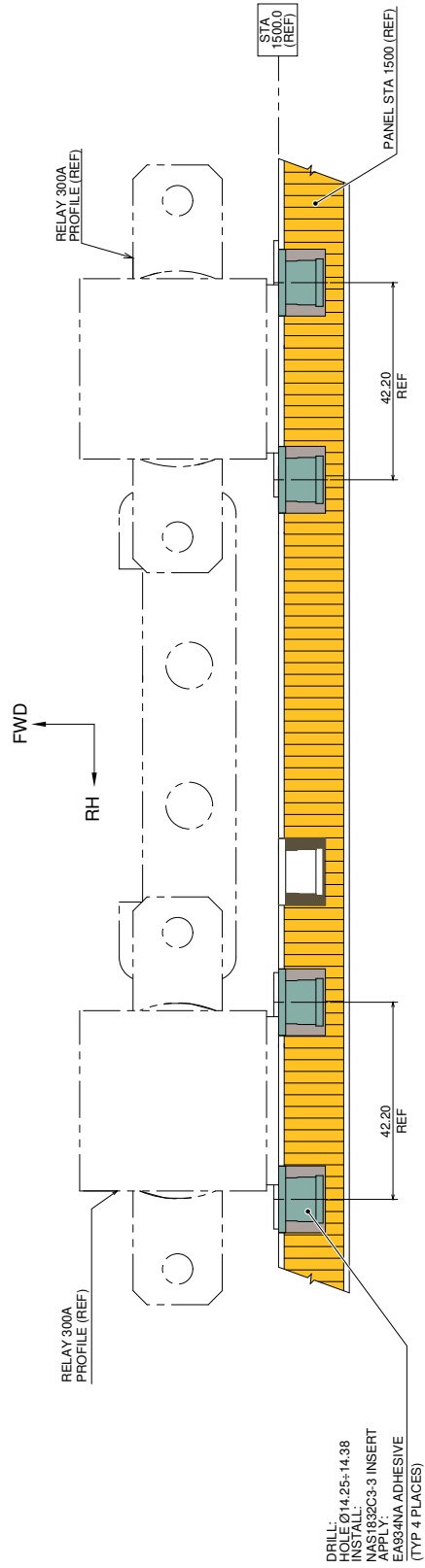

Figure 7

3G2430A00411
BATTERIES START IN PARALLEL
ELECTRICAL INSTALLATION

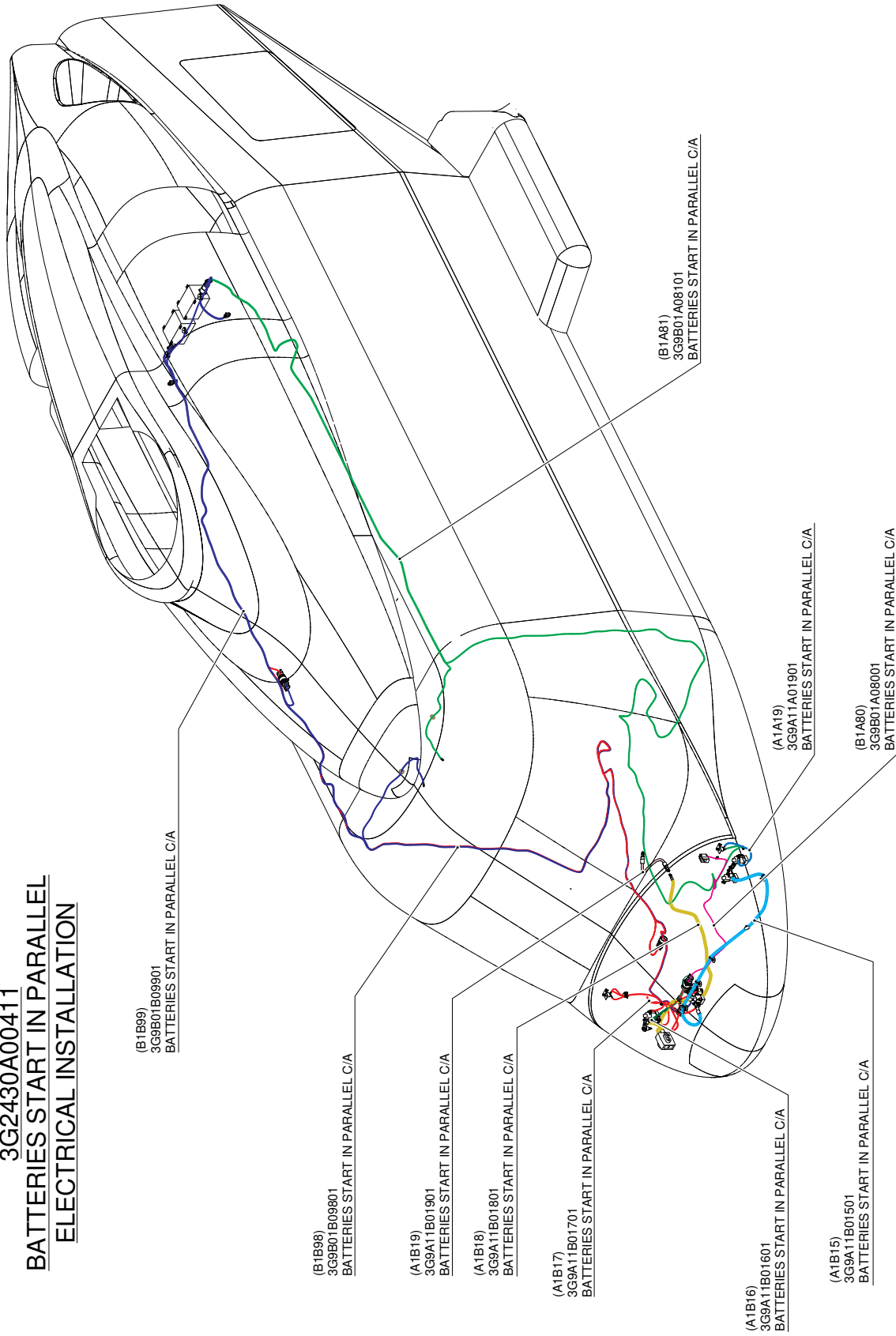

Figure 8

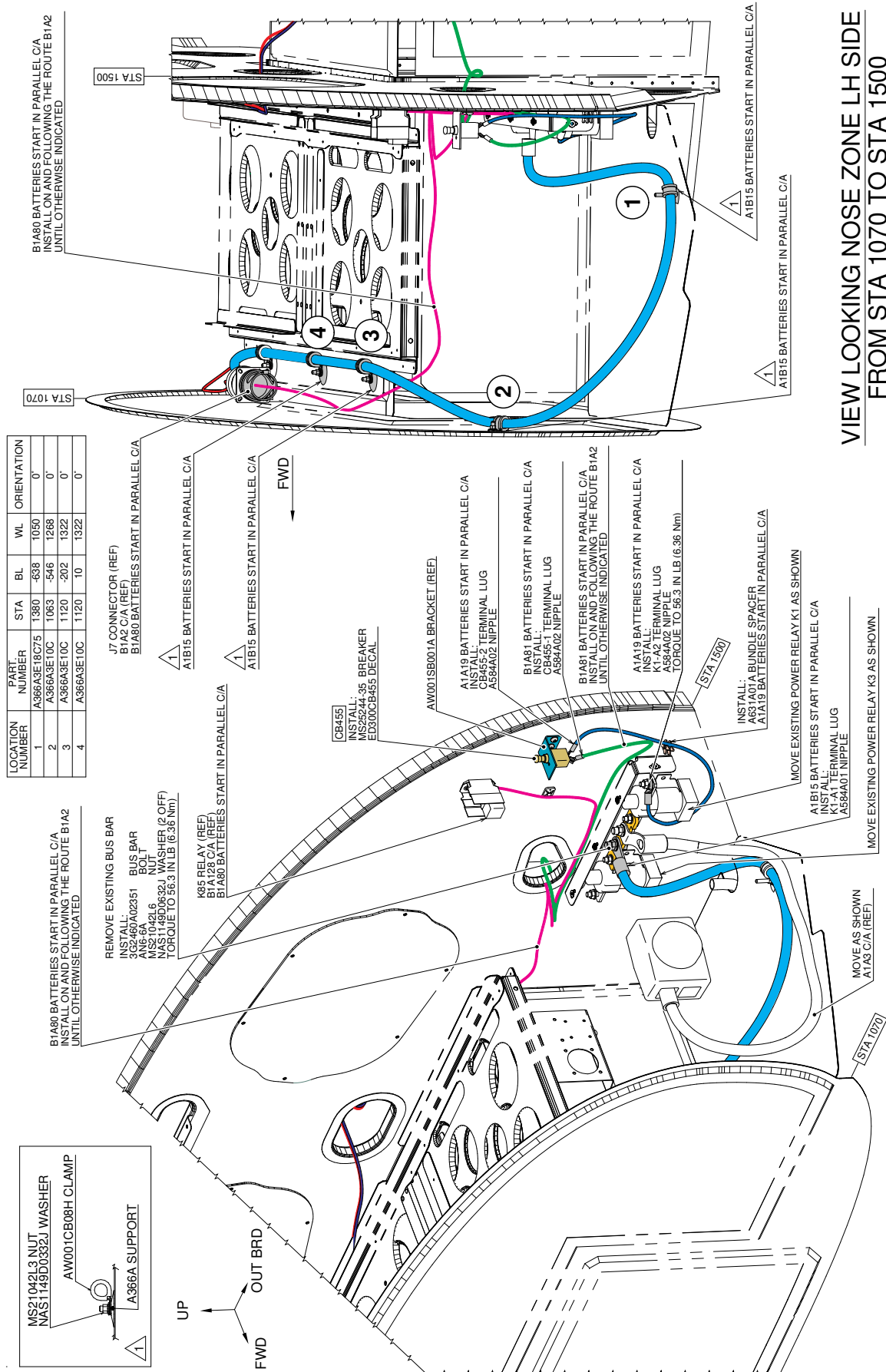

Figure 9

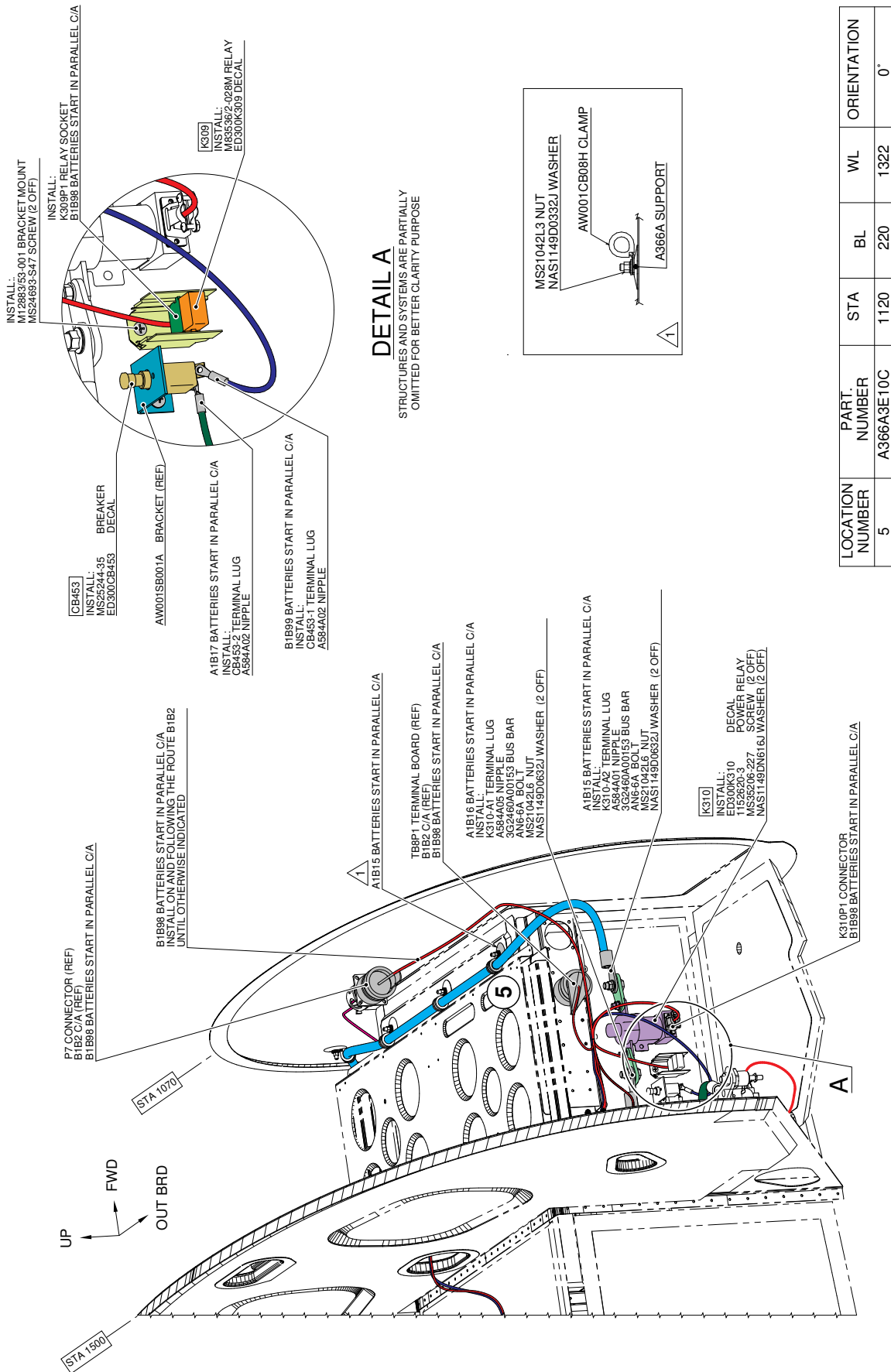

Figure 10

S.B. N°139-360

DATE: June 14, 2017

REVISION: A - October 22, 2021

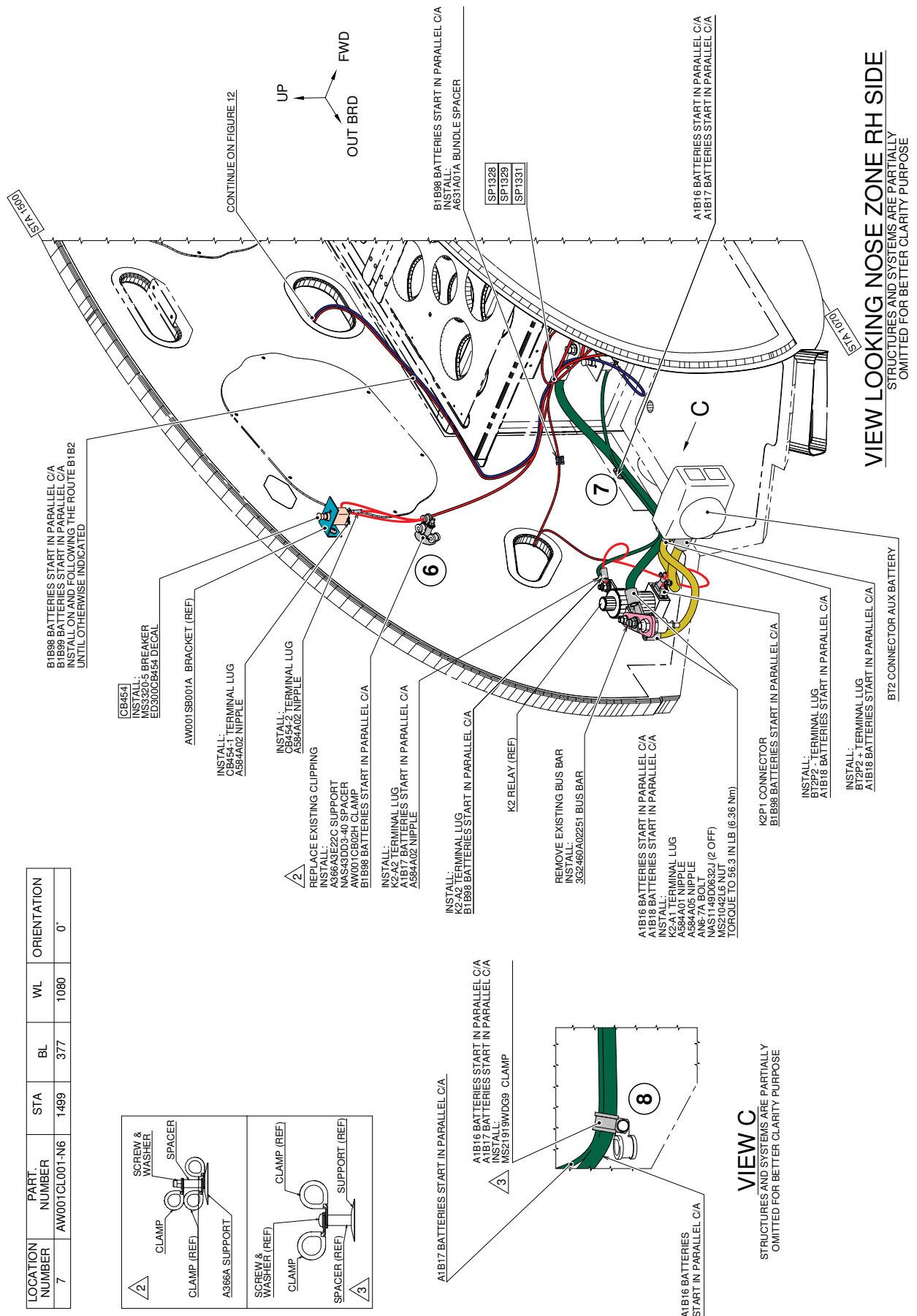
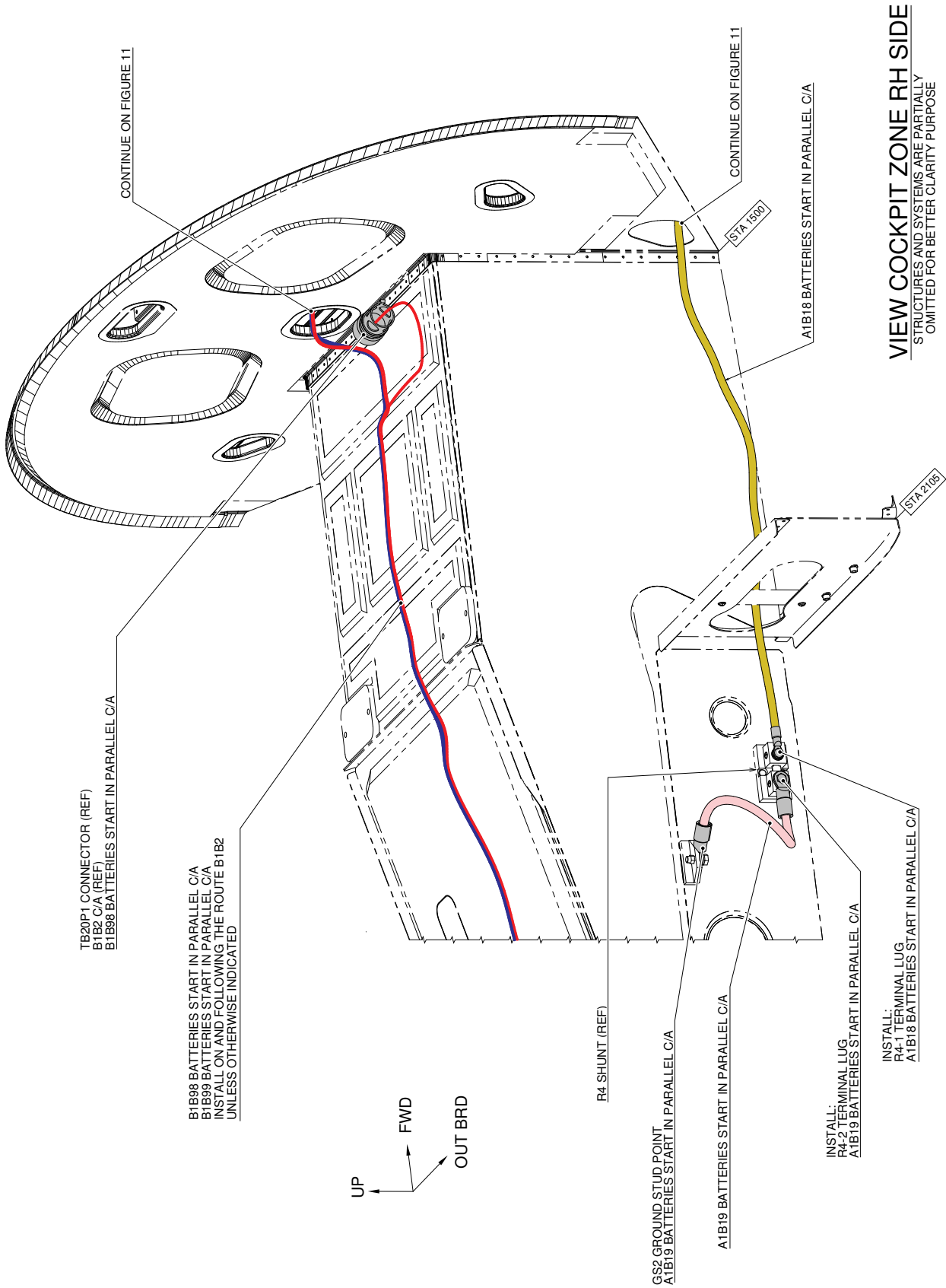
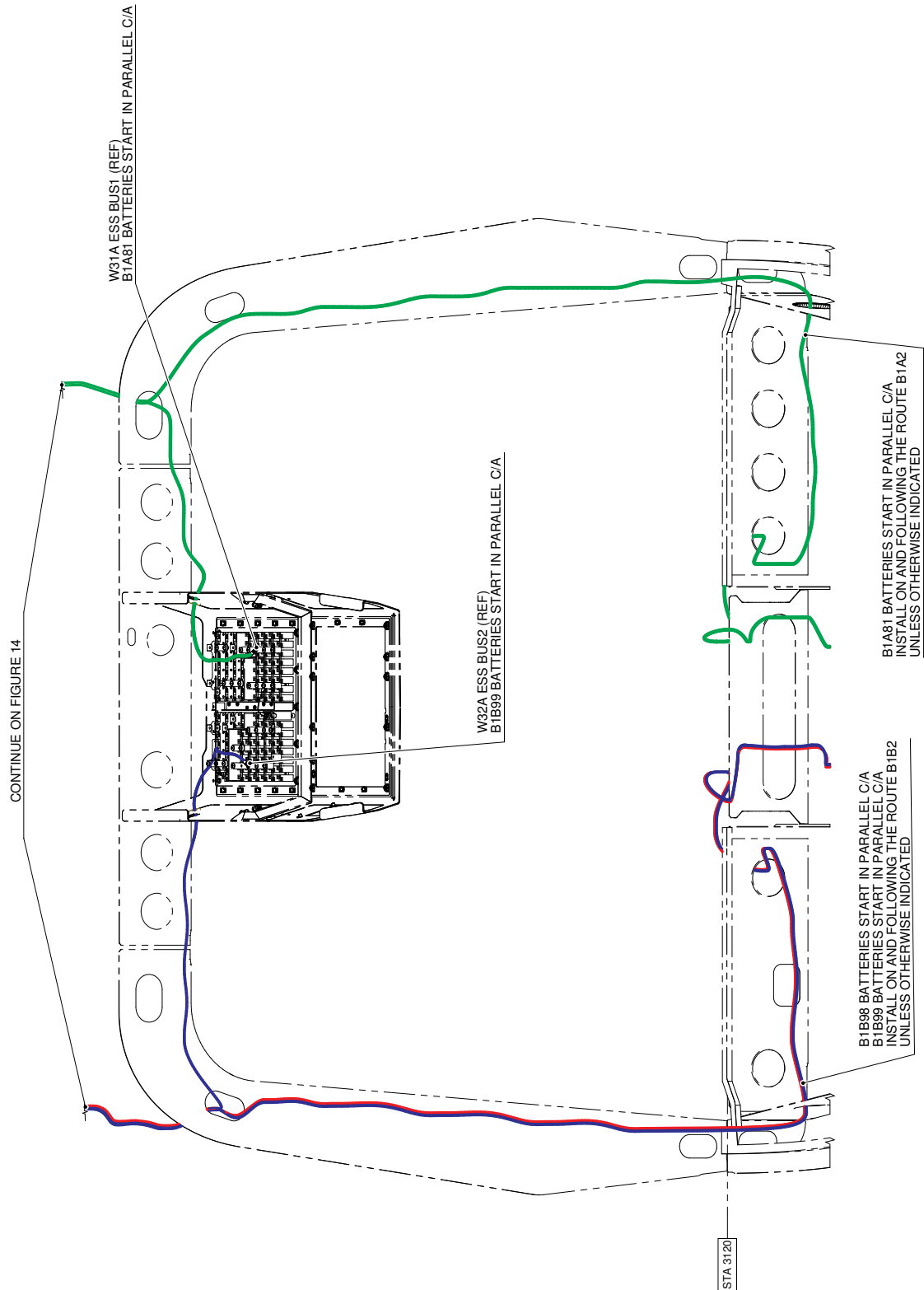

Figure 11



VIEW COCKPIT ZONE RH SIDE
STRUCTURES AND SYSTEMS ARE PARTIALLY OMITTED FOR BETTER CLARITY PURPOSE

Figure 12



VIEW LOOKING STA 3120 A.D.O.F.

STRUCTURES AND SYSTEMS ARE PARTIALLY
OMITTED FOR BETTER CLARITY PURPOSE

Figure 13

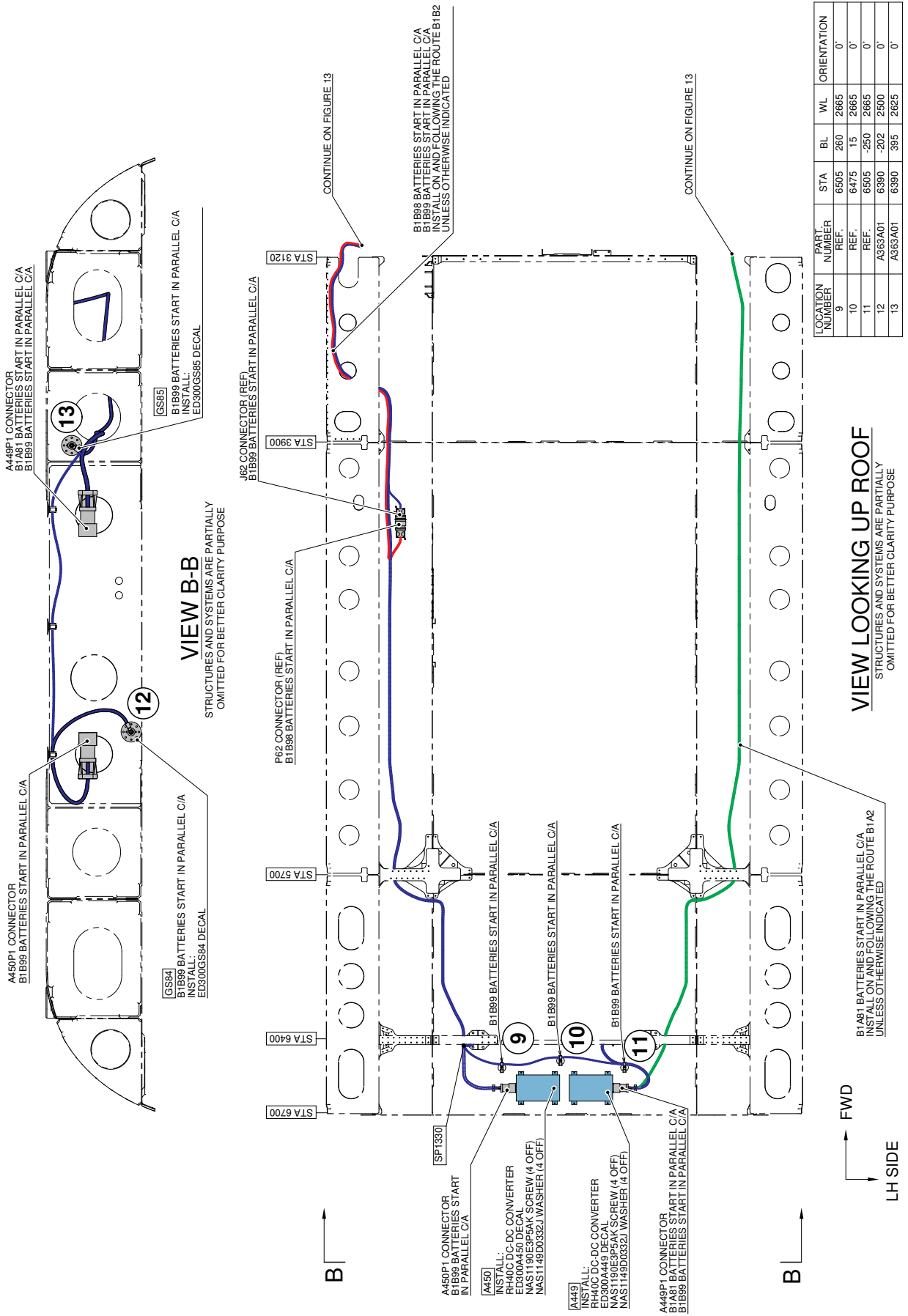
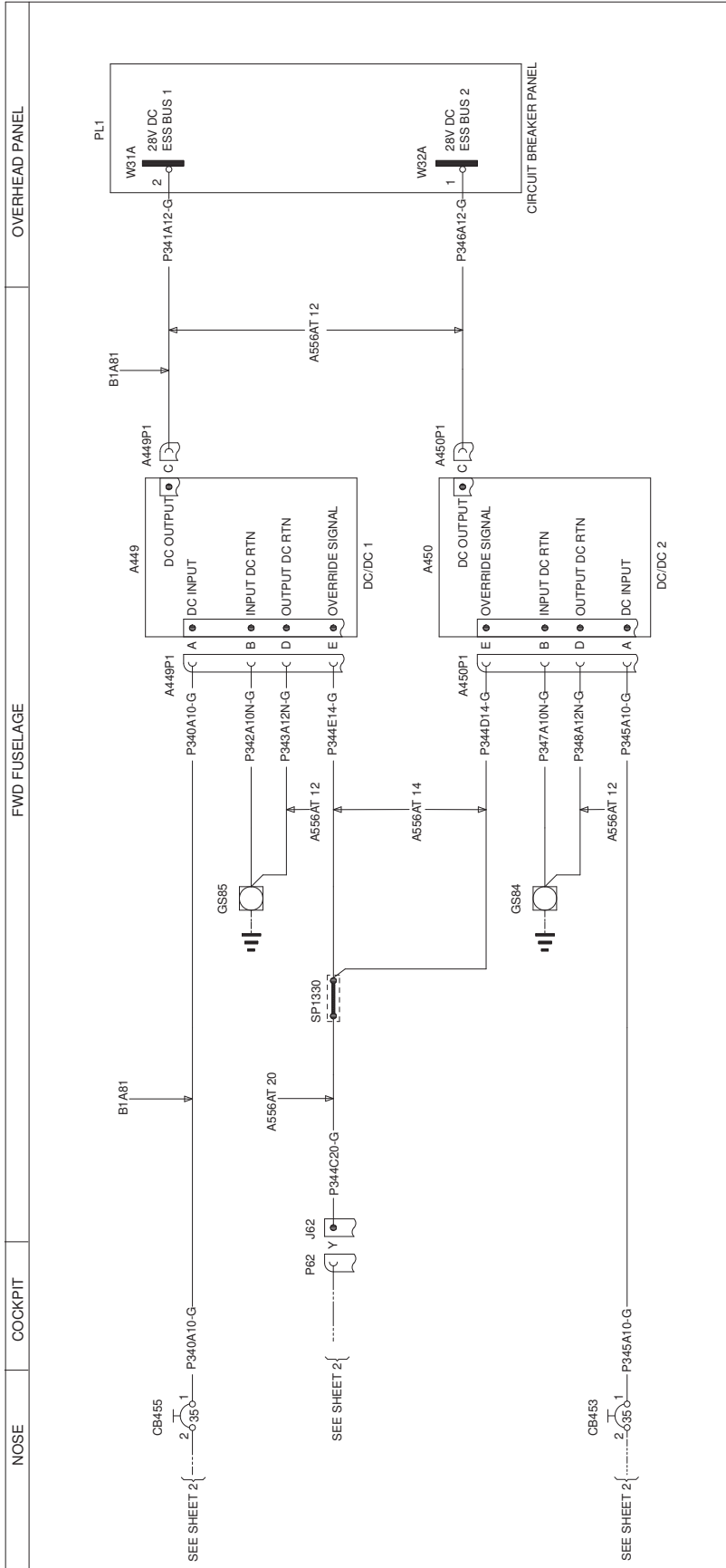

Figure 14

S.B. N°139-360
DATE: June 14, 2017

REVISION: A - October 22, 2021



3G2430W01101
WIRING DIAGRAM BATTERIES START IN PARALLEL
SHEET 1

FUNCTIONAL NOTES
ALL CABLES ARE IN LOOMB1B99 UNLESS SPECIFIED
ALL CABLES ARE OF TYPEA556AT 10 UNLESS SPECIFIED

Figure 15

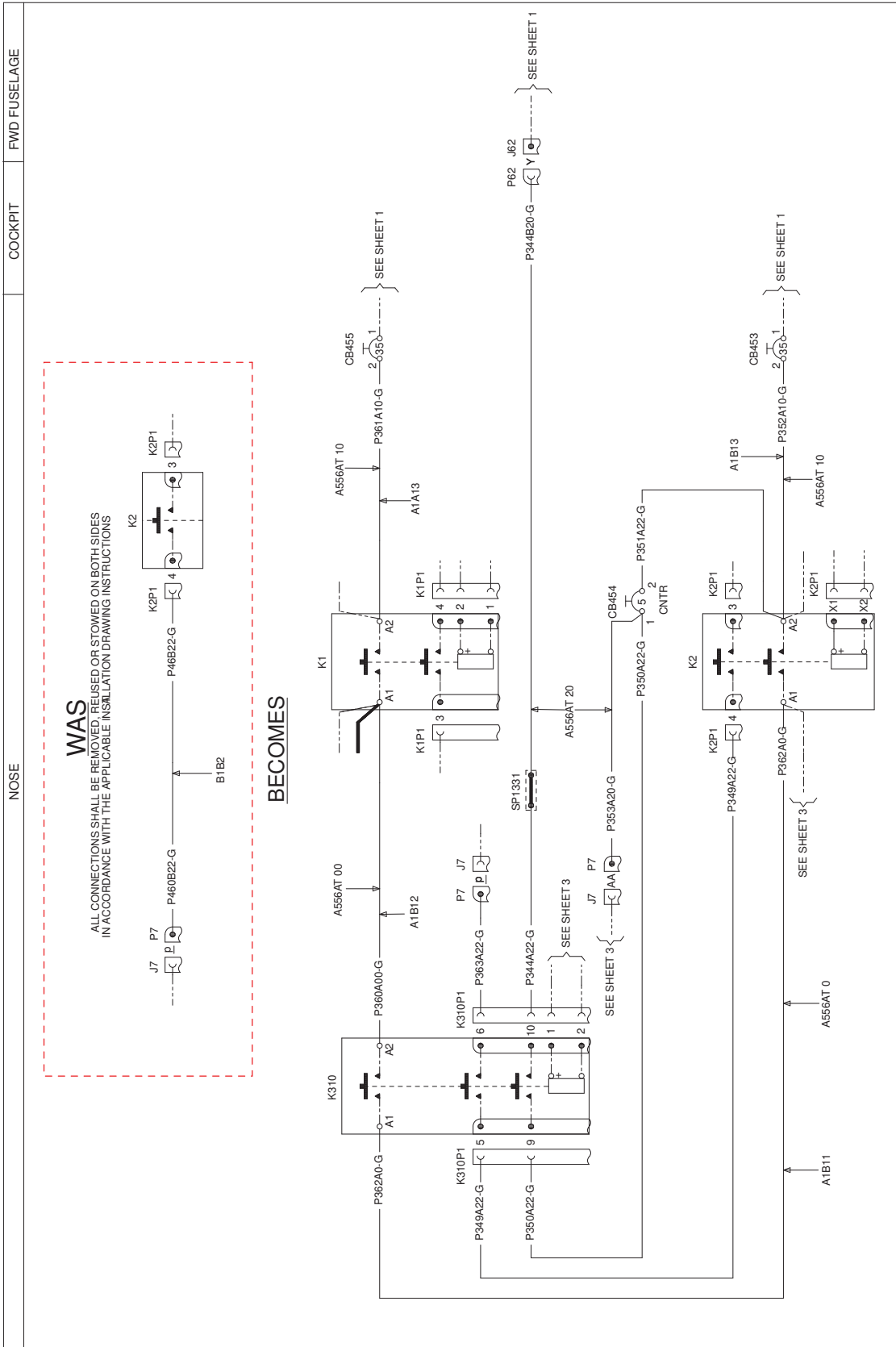

3G2430W01101
WIRING DIAGRAM BATTERIES START IN PARALLEL
SHEET 2

Figure 16

S.B. N°139-360

DATE: June 14, 2017

REVISION: A - October 22, 2021

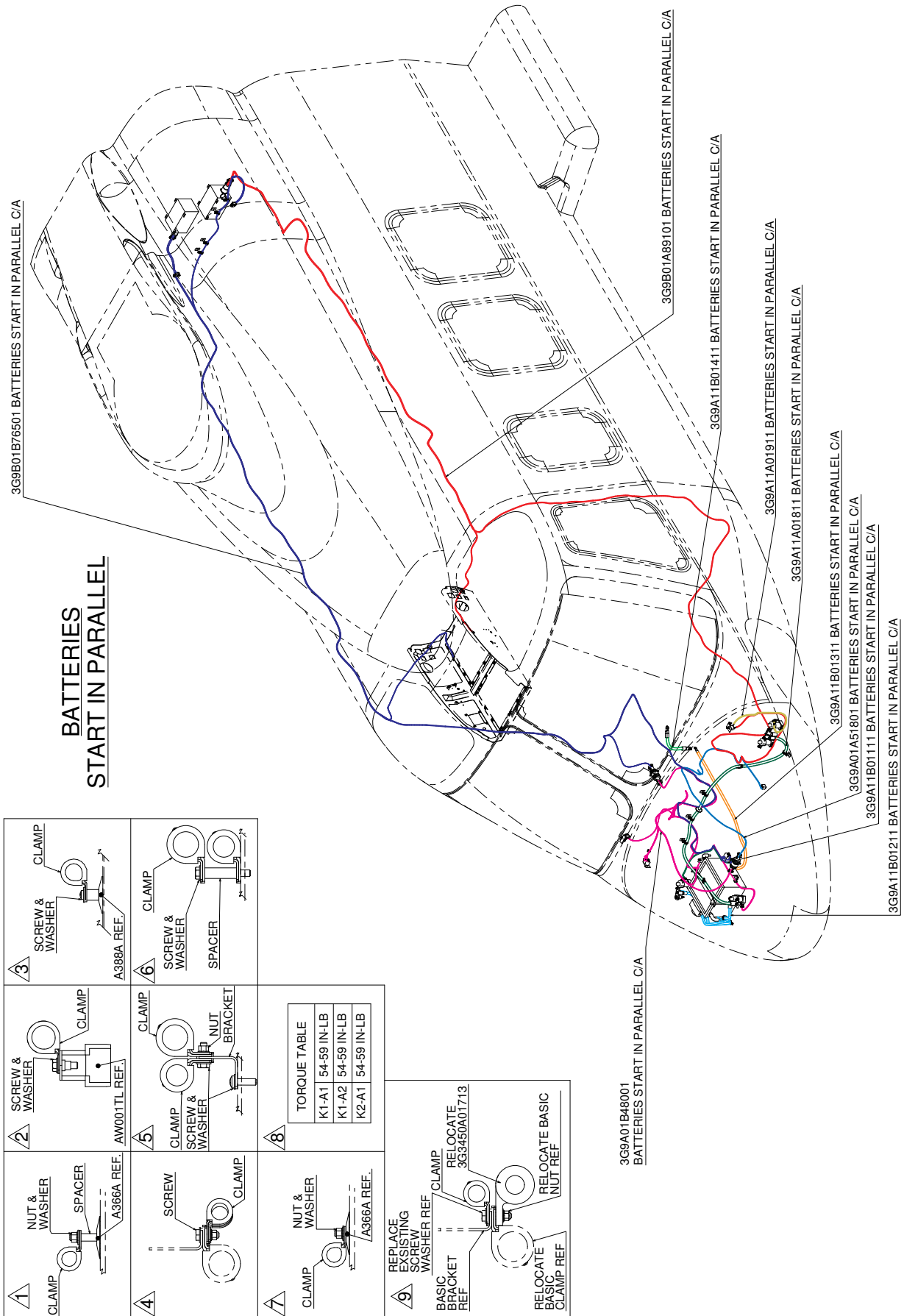
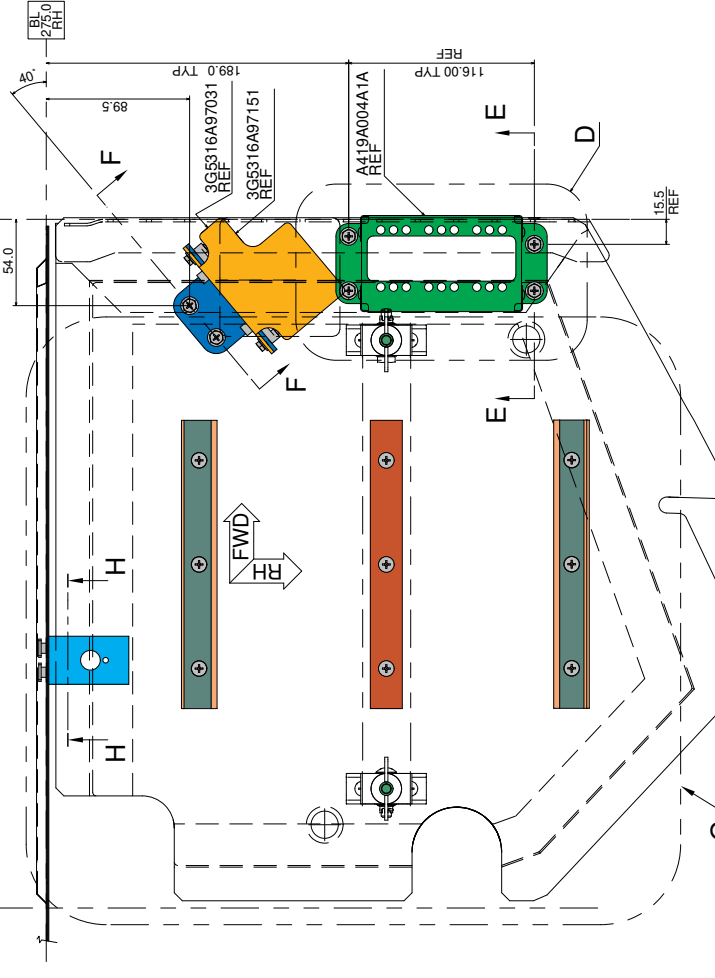
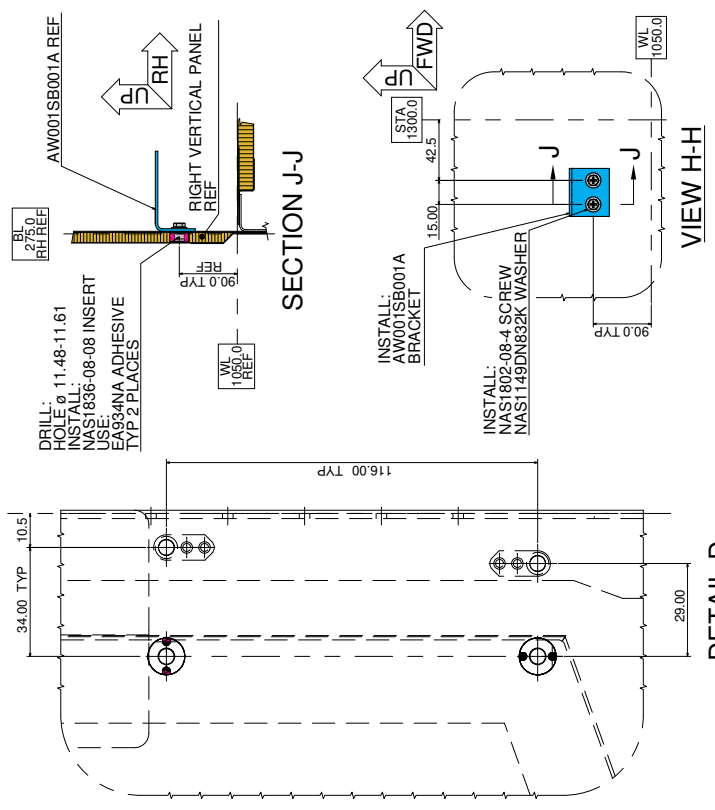
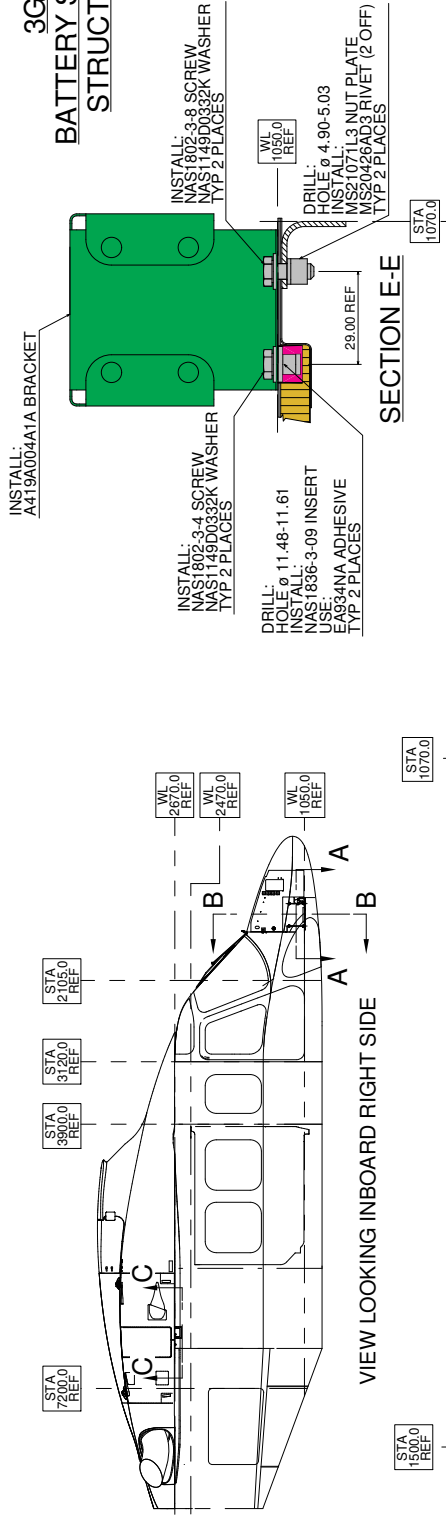

Figure 18

3G5310A89613
BATTERY START IN PARALLEL
STRUCTURAL PROVISION
(FIG. 15 THRU 18)



DETAIL D
3G5316A97151, A419A004A1A AND FASTENERS OMITTED FOR CLARITY

Figure 19

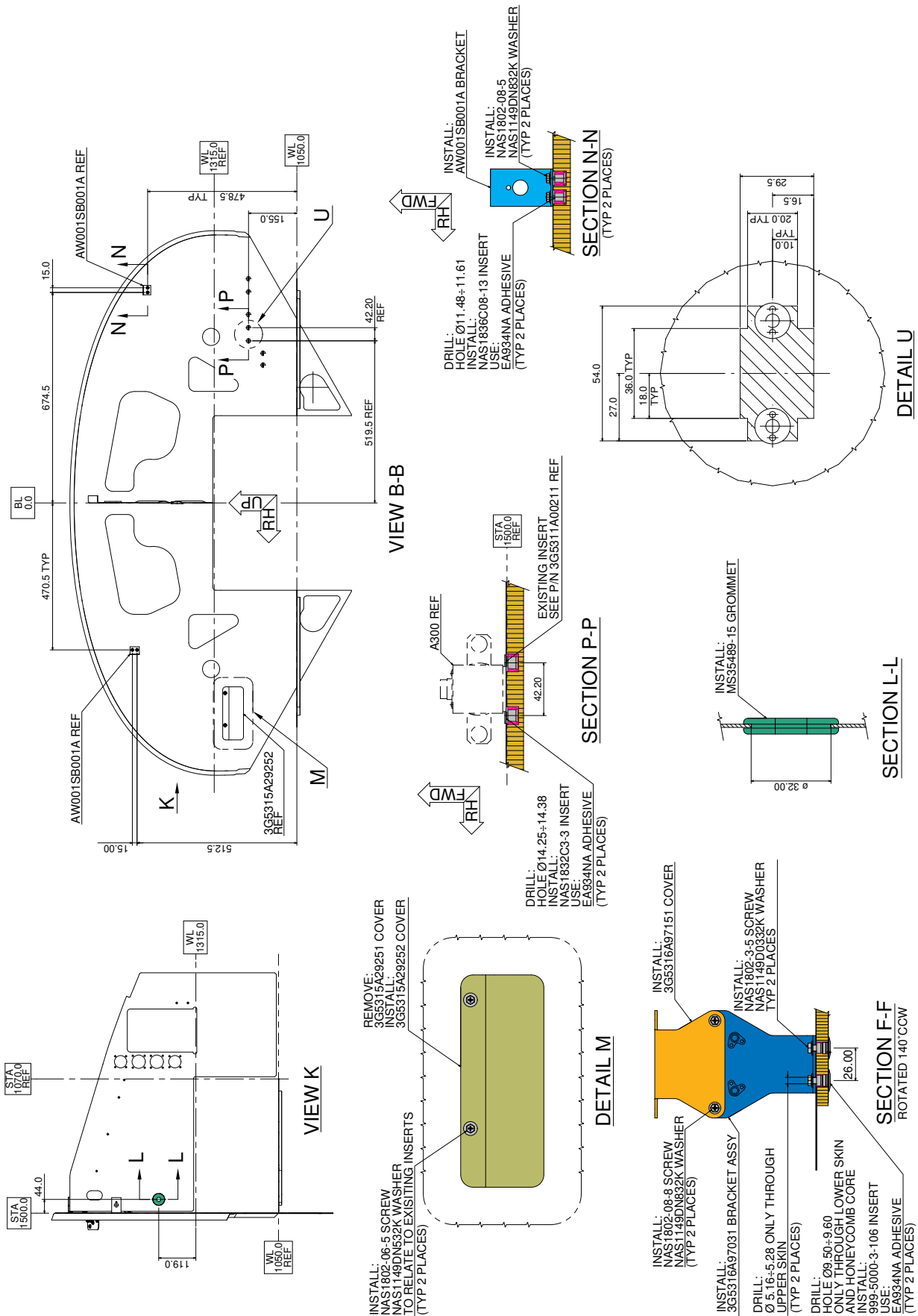

Figure 20

S.B. N°139-360

DATE: June 14, 2017

REVISION: A - October 22, 2021

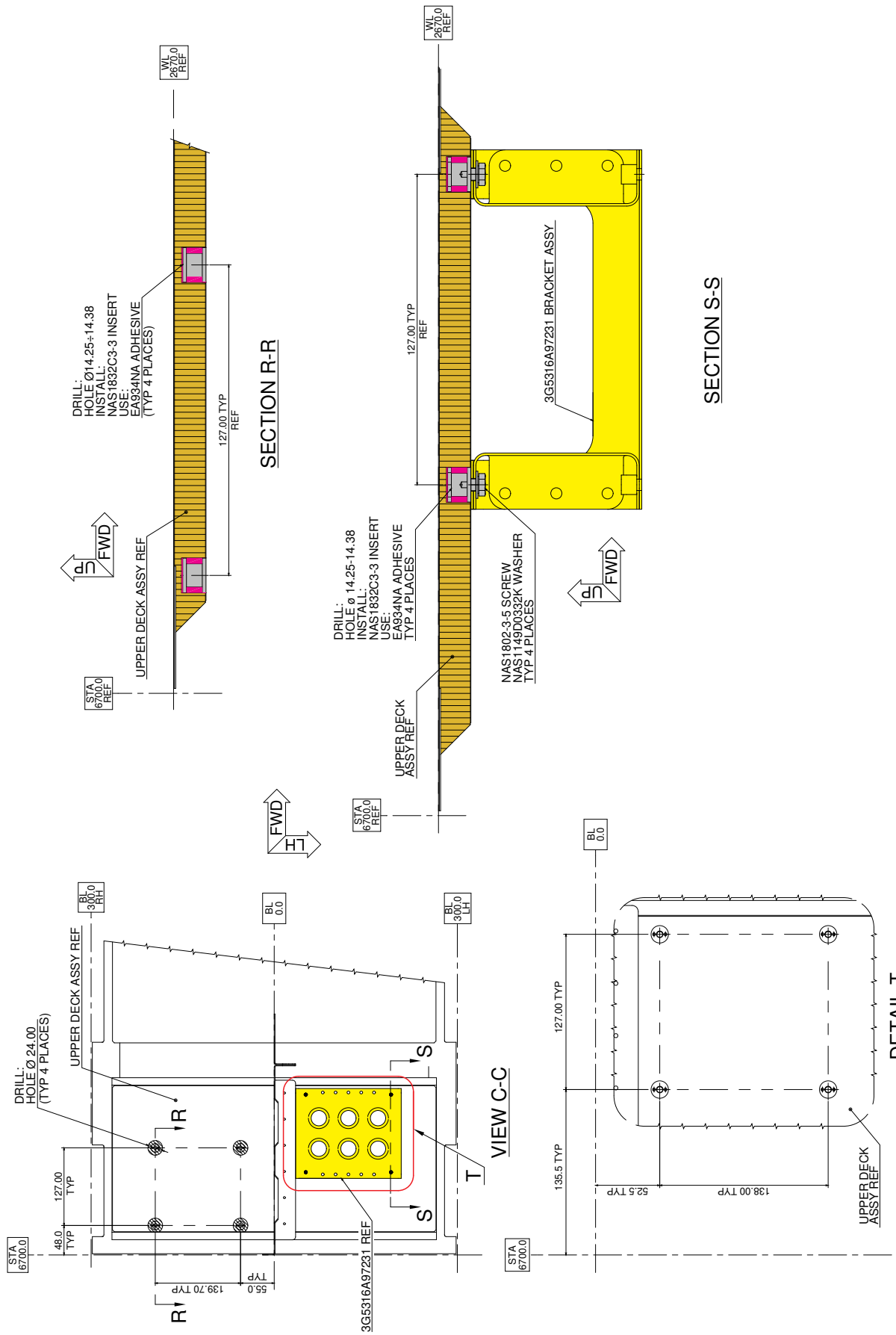
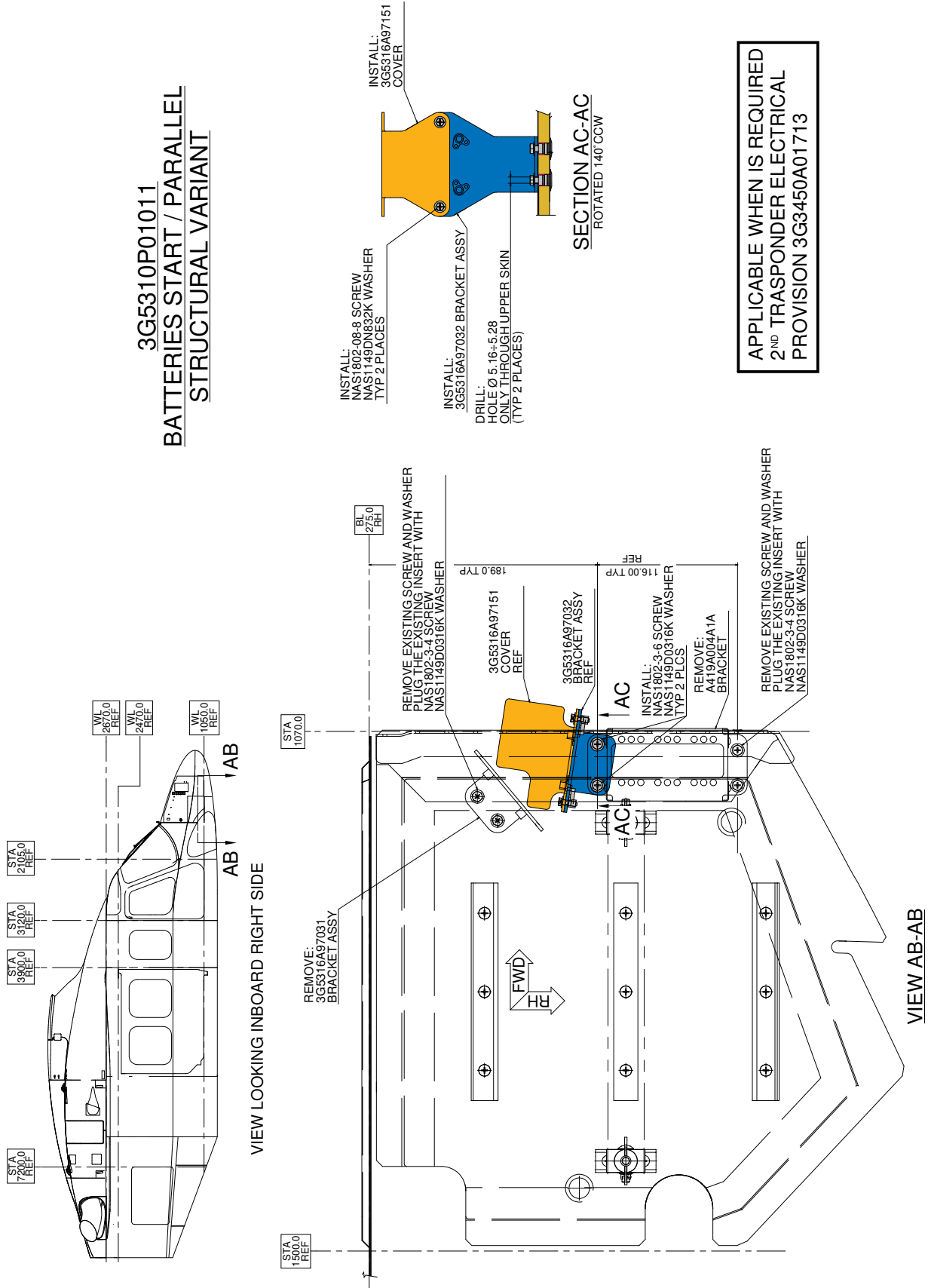

Figure 21

3G5310P01011
BATTERIES START / PARALLEL
STRUCTURAL VARIANT



APPLICABLE WHEN IS REQUIRED
2ND TRASPONDER ELECTRICAL
PROVISION 3G3450A01713

Figure 23

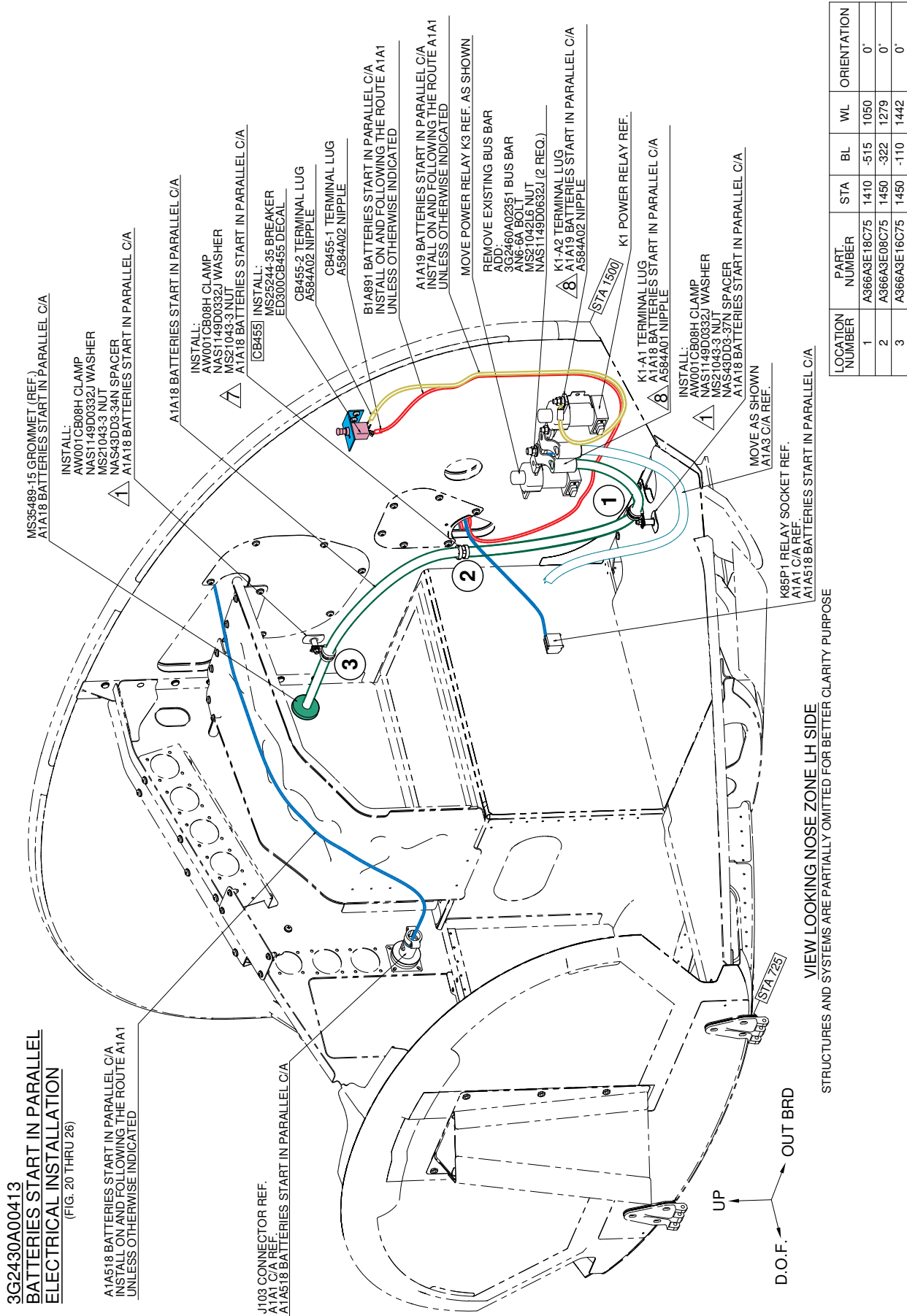

Figure 24

S.B. N°139-360

DATE: June 14, 2017

REVISION: A - October 22, 2021

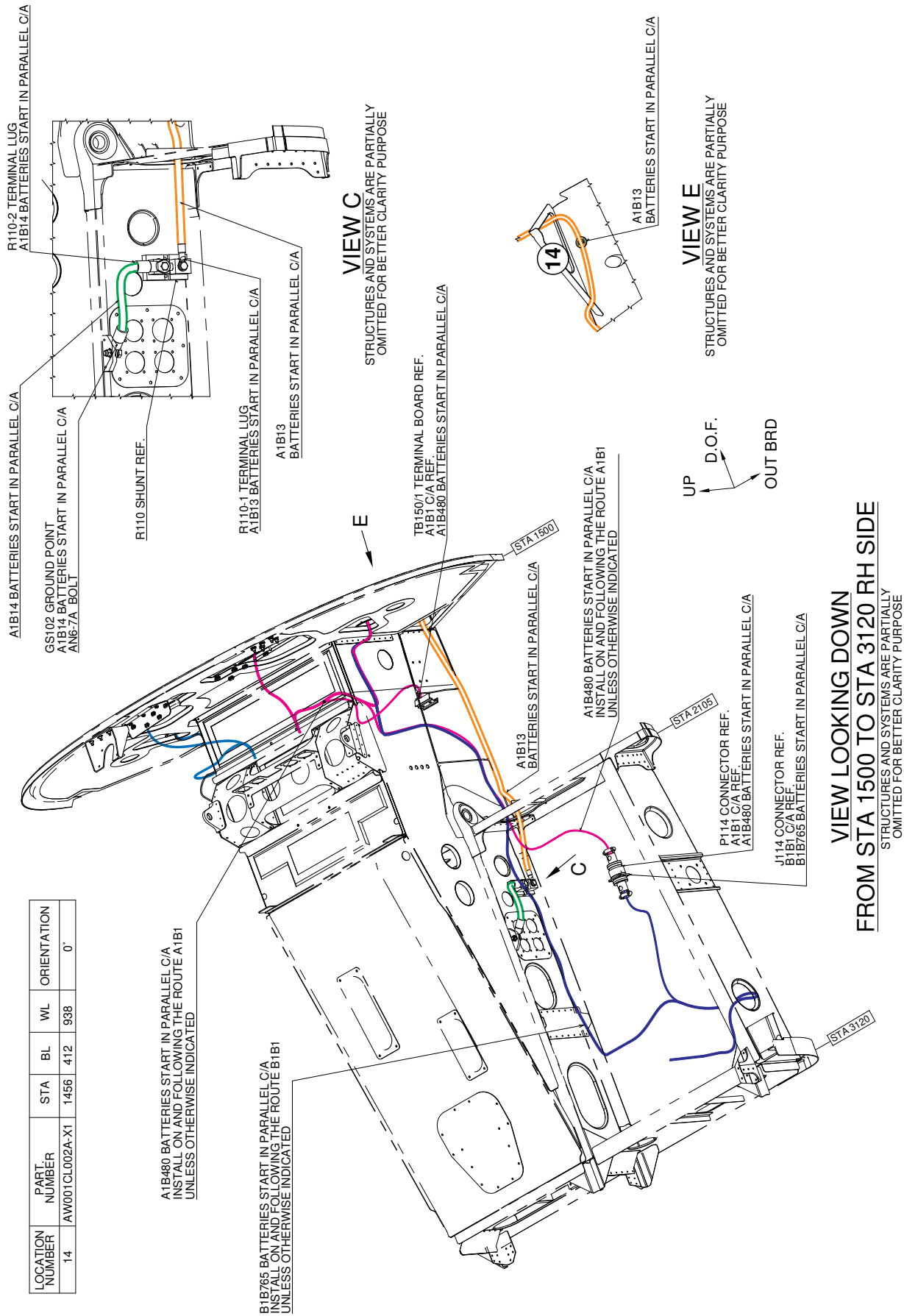
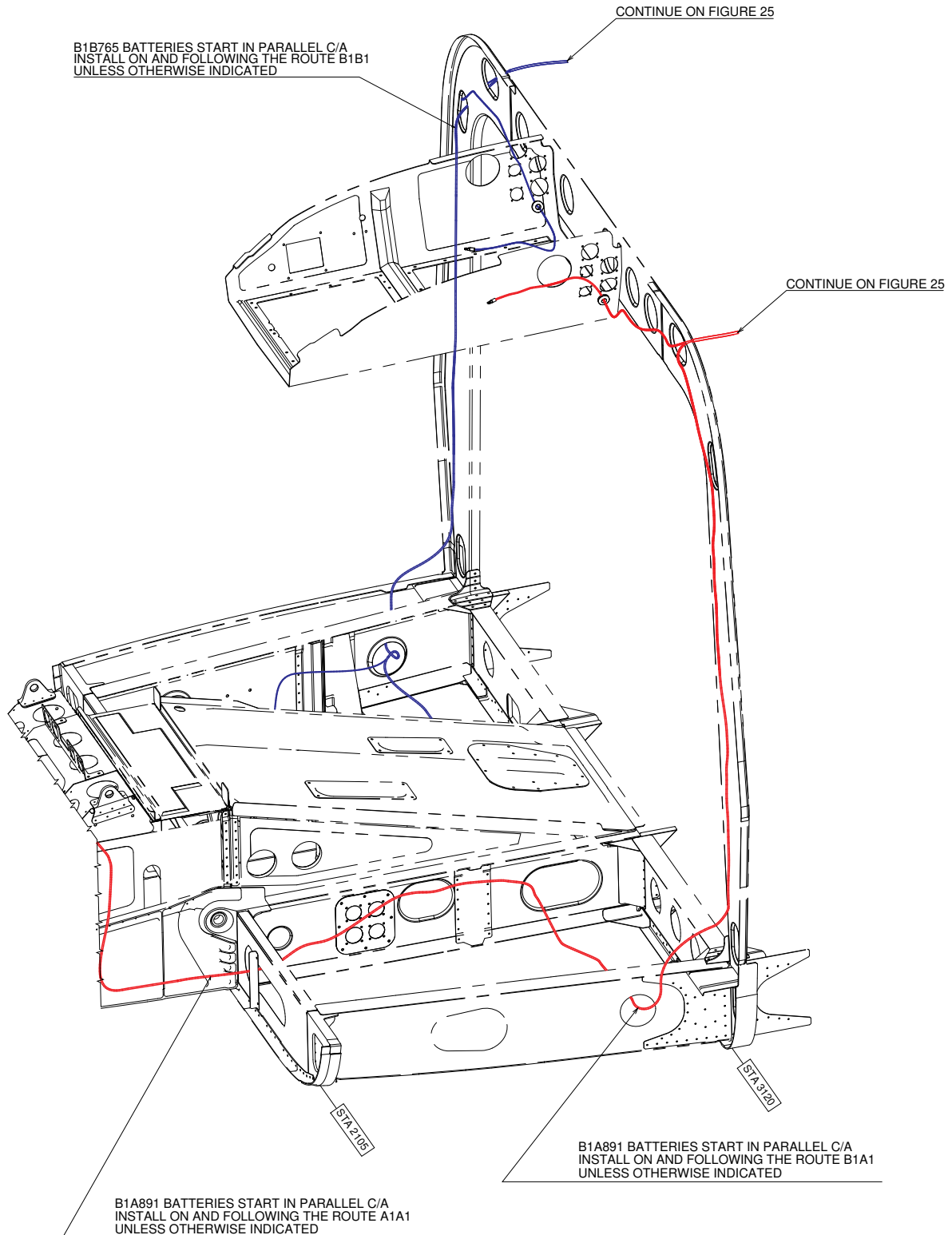

Figure 27



**VIEW LOOKING DOWN FROM
STA 1500 TO STA 3120 LH SIDE**

STRUCTURES AND SYSTEMS ARE PARTIALLY
OMITTED FOR BETTER CLARITY PURPOSE

SB139-360-021-01

Figure 28

S.B. N°139-360

DATE: June 14, 2017

REVISION: A - October 22, 2021

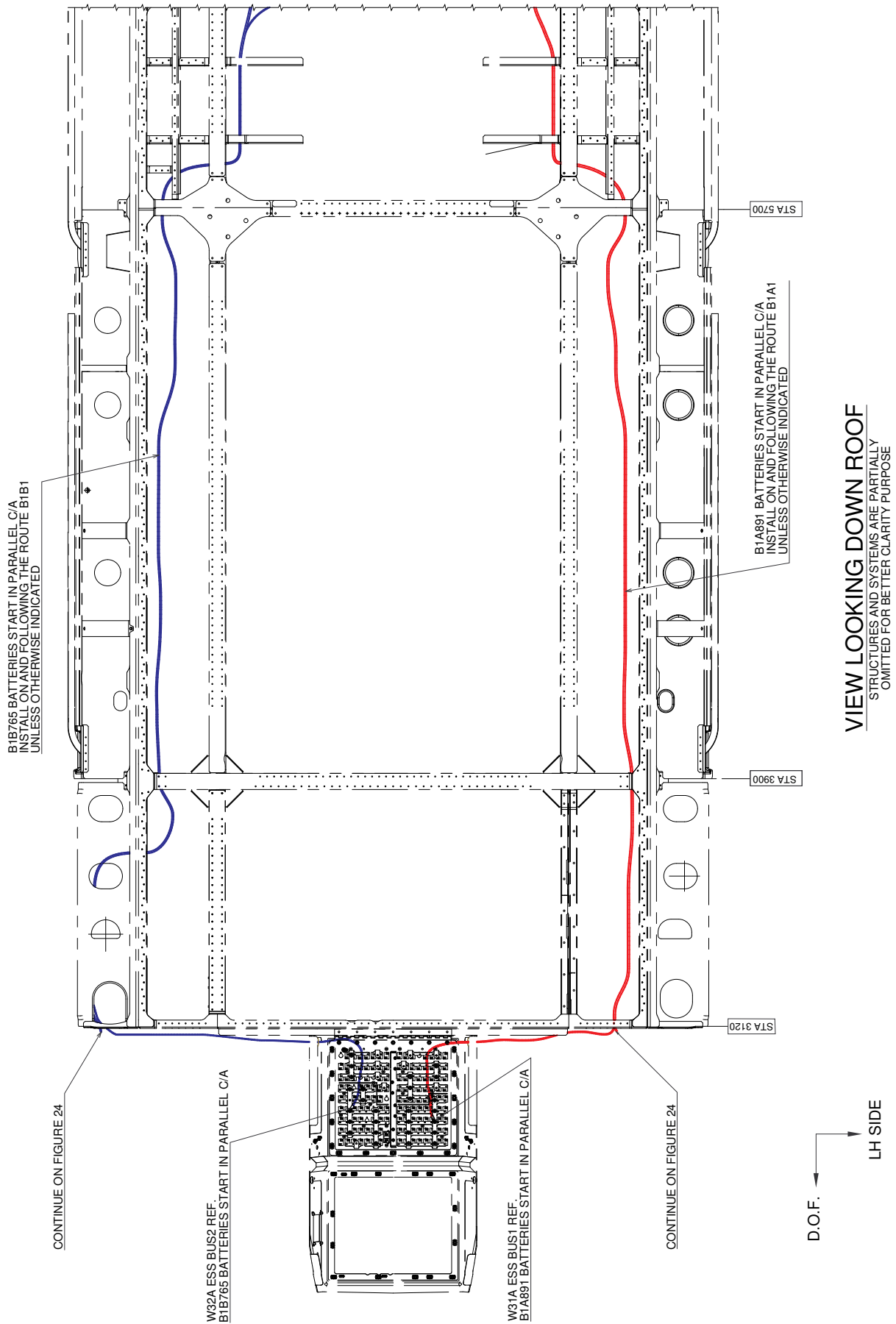
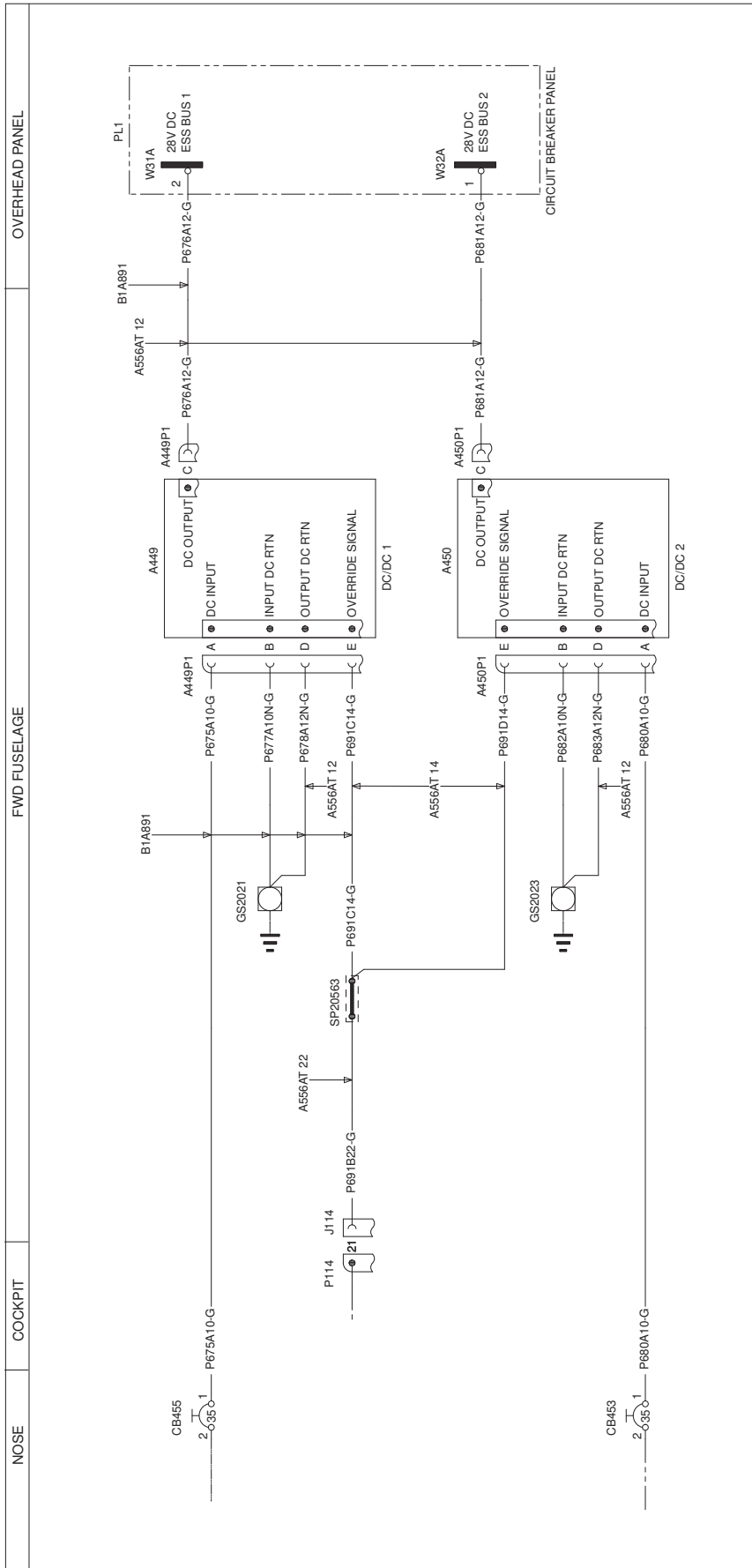

Figure 29



3G2430W01111
WIRING DIAGRAM BATTERIES START IN PARALLEL
SHEET 1

FUNCTIONAL NOTES
ALL CABLES ARE IN LOOM B1B765 UNLESS SPECIFIED
ALL CABLES ARE OF TYPE A556A 10 UNLESS SPECIFIED

Figure 31

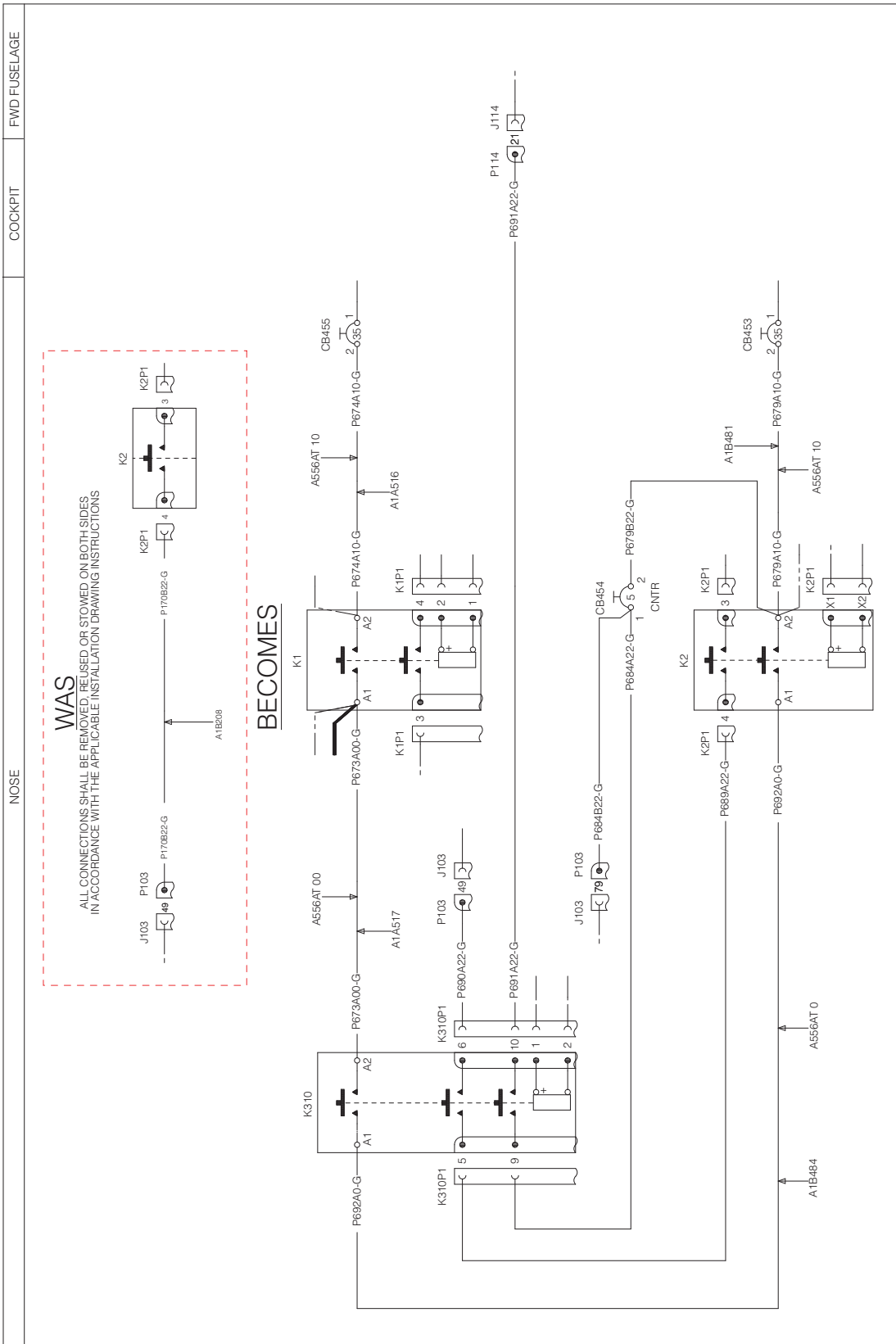

3G2430W01111
WIRING DIAGRAM BATTERIES START IN PARALLEL
SHEET 2

FUNCTIONAL NOTES
ALL CABLES ARE IN LOOM A1B480 UNLESS SPECIFIED
ALL CABLES ARE OF TYPE A556AT 22 UNLESS SPECIFIED

Figure 32

S.B. N°139-360

DATE: June 14, 2017

REVISION: A - October 22, 2021

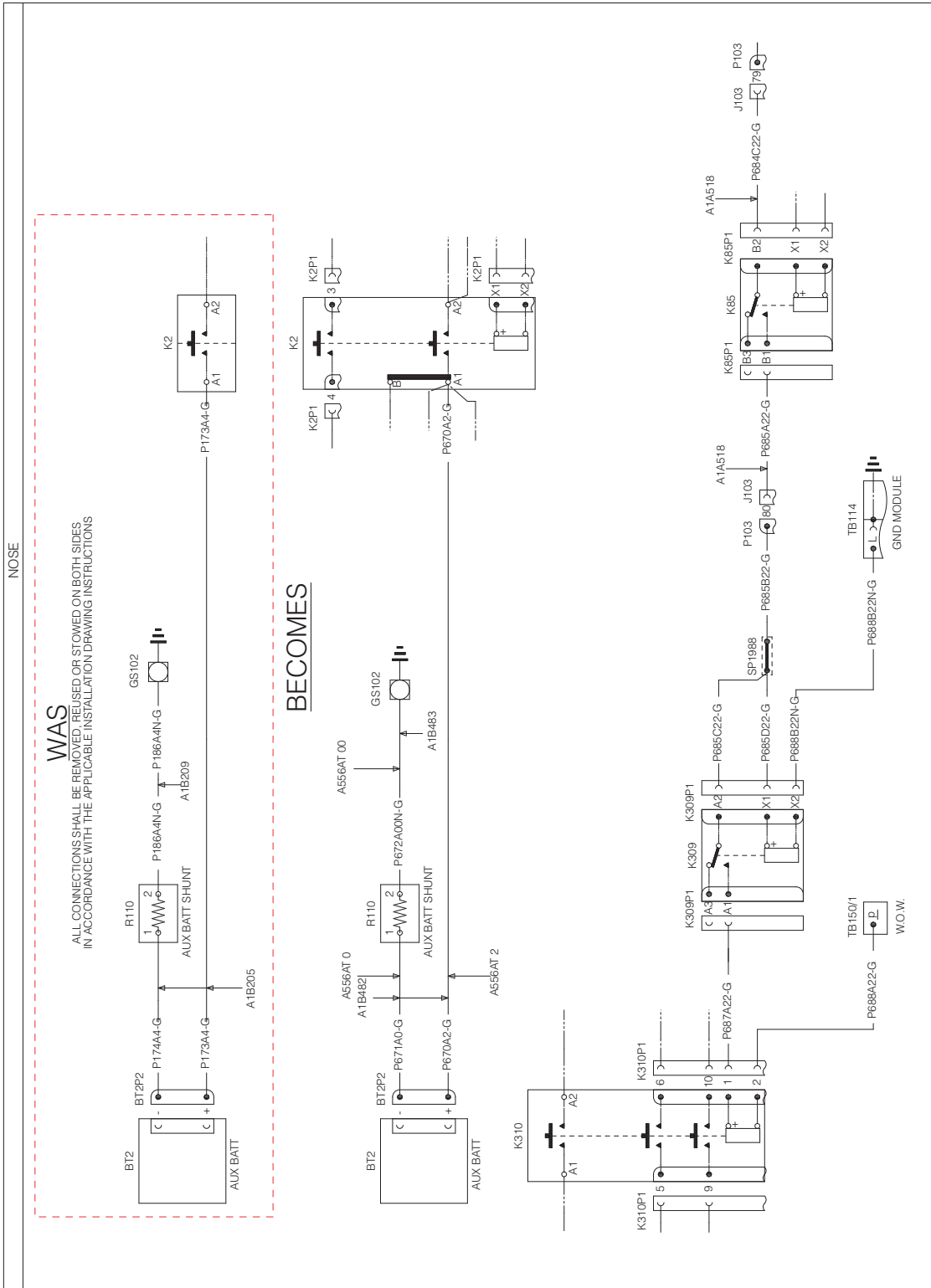

3G2430W01111
WIRING DIAGRAM BATTERIES START IN PARALLEL
SHEET 3

Figure 33

