SERVICE BULLETIN

N° 139-613

DATE: April 6, 2021

REV. : /

TITLE

ATA 95 - IMPROVEMENT OF EMERGENCY FLOATS RIGID COVER

REVISION LOG

First Issue

An appropriate entry should be made in the aircraft log book upon accomplishment.
If ownership of aircraft has changed, please, forward to new owner.

1. PLANNING INFORMATION

A. EFFECTIVITY

- ✓ AB139/AW139 helicopters equipped with float rigid covers listed in table 1.
- ✓ Spare float rigid cover listed in Table 1, kept in stock.

P/N	Description	S/N
3G9560V03751	Forward left rigid cover	all serial numbers up to S/N 120
3G9560V03851	Forward right rigid cover	
3G9560V03951	Aft left rigid cover	
3G9560V04051	Aft right rigid cover	

Table 1

NOTE

Float semi rigid assemblies are NOT affected if:

- Service Bulletin SB 025-69-13 is marked on the external identification label of EFS and/or
- Service Bulletin SB 139-613 is recorded on the component Log Card;

Even if they have a S/N listed above in table 1.

B. COMPLIANCE

At Customer's option.

C. CONCURRENT REQUIREMENTS

N.A.

D. REASON

This Service Bulletin is issued in order to provide the necessary instruction on how to improve the rigid cover damage resistance and the aluminum hinges corrosion resistance.

E. DESCRIPTION

This Service Bulletin is issued to:

- Add a metallic plate on the FWD rigid cover over the AFT upper frangible hinge.
- Add a ply of fiberglass.
- Replace the hinges.
- Perform a drain hole on the rigid covers.

F. APPROVAL

The technical content of this Service Bulletin is approved under the authority of DOA nr. EASA.21.J.005. For helicopters registered under other Aviation Authorities, before applying the Service Bulletin, applicable Aviation Authority approval must be checked within Leonardo Helicopters customer portal.

EASA states mandatory compliance with inspections, modifications or technical directives and related time of compliance by means of relevant Airworthiness Directives. If an aircraft listed in the effectivity embodies a modification or repair not LHD certified and affecting the content of this Service Bulletin, it is responsibility of the Owner/Operator to obtain a formal approval by Aviation Authority having jurisdiction on the aircraft, for any adaptation necessary before incorporation of the present Service Bulletin.

G. MANPOWER

To comply with this Service Bulletin twenty-four (24) MMH are deemed necessary.

MMH are based on hands-on time and can change with personnel and facilities available.

H. WEIGHT AND BALANCE

N.A.

I. REFERENCES

1) PUBLICATIONS

Following Data Modules refer to AMP:

<u>DATA MODULE</u>	<u>DESCRIPTION</u>	<u>PART</u>
DM01 39-A-00-20-00-00A-120A-A	Helicopter on ground for a safe maintenance	-
DM02 39-B-95-61-16-00A-520A-K	Forward left cover - Remove procedure	-
DM03 39-B-95-61-17-00A-520A-K	Forward right cover - Remove procedure	-
DM04 39-B-95-61-18-00A-520A-K	Aft left cover - Remove procedure	-
DM05 39-B-95-61-19-00A-520A-K	Aft right cover - Remove procedure	-
DM06 39-B-95-61-16-00A-720A-K	Forward left cover - Install procedure	-
DM07 39-B-95-61-17-00A-720A-K	Forward right cover - Install procedure	-
DM08 39-B-95-61-18-00A-720A-K	Aft left cover - Install procedure	-

<u>DATA MODULE</u>	<u>DESCRIPTION</u>	<u>PART</u>
DM09 39-B-95-61-19-00A-720A-K	Aft right cover - Install procedure	-

2) ACRONYMS & ABBREVIATIONS

AMP	Aircraft Maintenance Publication
DM	Data Module
DOA	Design Organization Approval
EASA	European Aviation Safety Agency
IPD	Illustrated Parts Data
LHD	Leonardo Helicopters Division
MMH	Maintenance-Man-Hours
P/N	Part Number
S/N	Serial Number

3) ANNEX

Annex A Zodiac Aerospace Service Bulletin 025-69-13

J. PUBLICATIONS AFFECTED

AW139 IPD

K. SOFTWARE ACCOMPLISHMENT SUMMARY

N.A.

2. MATERIAL INFORMATION

A. REQUIRED MATERIALS

1) PARTS

Refer to chapter 2 "Material information" of Zodiac Aerospace Service Bulletin 025-69-13.

2) CONSUMABLES

Refer to chapter 2 "Material information" of Zodiac Aerospace Service Bulletin 025-69-13.

3) LOGISTIC MATRIX

N.A.

B. SPECIAL TOOLS

Refer to chapter 2 "Material information" of Zodiac Aerospace Service Bulletin 025-69-13.

C. INDUSTRY SUPPORT INFORMATION

Product improvement.

3. ACCOMPLISHMENT INSTRUCTIONS

GENERAL NOTES

- a) Place an identification tag on all components that are re-usable, including the attaching hardware that has been removed to gain access to the modification area and adequately protect them until their later re-use.
- b) Exercise extreme care during drilling operations to prevent instruments, cables and hoses damage.
- c) After drilling, remove all swarf and sharp edges. Apply on bare metal a light film of primer unless the hole is used for ground connection.
- d) Let adhesive cure at room temperature for at least 24 hours unless otherwise specified.
- e) All lengths are in mm.

NOTE

Steps from 1 to 5 are not applicable for components kept in stock.

- 1. In accordance with AMP DM 39-A-00-20-00-00A-120A-A, prepare the helicopter on ground for a safe maintenance. Disconnect the battery, all electrical power sources and/or the external power supply.
- 2. In accordance with AMP DM 39-B-95-61-16-00A-520A-K remove the FWD left rigid cover assy P/N 3G9560V03751.
- 3. In accordance with AMP DM 39-B-95-61-17-00A-520A-K remove the FWD right rigid cover assy P/N 3G9560V03851.
- 4. In accordance with AMP DM 39-B-95-61-18-00A-520A-K remove the AFT left rigid cover assy P/N 3G9560V03951.
- 5. In accordance with AMP DM 39-B-95-61-19-00A-520A-K remove the AFT right rigid cover assy P/N 3G9560V04051.
- 6. Rework and remark the rigid covers as described in the Zodiac Aerospace Service Bulletin 025-69-13 in Annex A.
- 7. As requested in the step 2, section E, chapter 3 of the SB 025-69-13, record the compliance with this Service Bulletin on the component Log Card.

NOTE

Steps from 8 to 11 are not applicable for components kept in stock when an installation on the helicopter is not needed.

8. In accordance with AMP DM 39-B-95-61-16-00A-720A-K install the FWD left rigid cover assy P/N 3G9560V03752.
9. In accordance with AMP DM 39-B-95-61-17-00A-720A-K install the FWD right rigid cover assy P/N 3G9560V03852.
10. In accordance with AMP DM 39-B-95-61-18-00A-720A-K install the AFT left rigid cover assy P/N 3G9560V03952.
11. In accordance with AMP DM 39-B-95-61-19-00A-720A-K install the AFT right rigid cover assy P/N 3G9560V04052.

NOTE

The following step is not applicable for components kept in stock.

12. Return the helicopter to flight configuration and record for compliance with this Service Bulletin on the helicopter logbook.
13. Send the attached compliance form to the following mail box:

engineering.support.lhd@leonardocompany.com

As an alternative, gain access to My Communications section on Leonardo WebPortal and compile the "Service Bulletin Application Communication".

ANNEX A

ZODIAC AEROSPACE SERVICE BULLETIN

025-69-13

IMPROVEMENT OF RIGID COVERS

ZODIAC AEROSPACE SERVICES



ZODIAC AEROSPACE SERVICES

Technical Publication Department
61 rue Pierre Curie
CS20001
78373 PLAISIR CEDEX
FRANCE
Phone international: + 33 1 61 34 23 23
Fax international: + 33 1 61 34 21 08
Web site: www.services.zodiacaerospace.com

TRANSMITTAL SHEET

This Transmittal Sheet applies to the Basic Issue, dated JUNE 01/18, of Service Bulletin 025-69-13

REASON FOR REVISION

- Initial Issue

REVISION SEQUENCE

Initial Issue JUNE 01/18

Issue date : JUN 01/18

SB 025-69-13

REV 0
Page 1/2

THIS PAGE INTENTIONALLY LEFT BLANK

Issue date : JUN 01/18

SB 025-69-13

REV 0
Page 2/2



ZODIAC EVACUATION SYSTEMS

61 rue Pierre Curie – CS20001 – 78373 Plaisir Cedex – France
 Tel: + 33 1 61 34 23 23 – Fax: + 33 1 61 34 24 23
 http://www.zodiac aerospace.com
 CAGE Code: F6101

SERVICE BULLETIN

TITLE:

IMPROVEMENT OF RIGID COVERS

SUMMARY

-EFFECTIVITY (AFFECTED P/N)

REFERENCE (ASY)	REFERENCE (CUSTOMER)	DESIGNATION
220980-0	3G9560V03751	FWD LEFT RIGID COVER ASSY
220981-0	3G9560V03851	FWD RIGHT RIGID COVER ASSY
220982-0	3G9560V03951	AFT LEFT RIGID COVER ASSY
220983-0	3G9560V04051	AFT RIGHT RIGID COVER ASSY

-REASON

Damage to the forward rigid covers when the pilot doors are closed with the latch in the closed position.
 Corrosion of aluminum hinges.

-BENEFIT

Prevents damage to the rigid covers and galvanic corrosion between aluminum hinges and rigid covers and therefore the need for replacements.

-COMPLIANCE

Application of present service bulletin is recommended for AW139 EFS.

-DESCRIPTION

Addition of a metallic plate on the FWD rigid covers over the aft upper frangible hinge.
 Addition of a ply of fiberglass and replacement of hinges.
 Addition of a drain hole on the covers.

-MANPOWER

6h per cover (excluding cure time).

Issue date : JUN 01/18

SB 025-69-13

REV 0
 Page 1/14

1. Planning information

A. Effectivity

REFERENCE (ASY)	REFERENCE (LHD)	DESIGNATION	S/N
220980-0	3G9560V03751	FWD LEFT RIGID COVER ASSY	<120
220981-0	3G9560V03851	FWD RIGHT RIGID COVER ASSY	<120
220982-0	3G9560V03951	AFT LEFT RIGID COVER ASSY	<120
220983-0	3G9560V04051	AFT RIGHT RIGID COVER ASSY	<120

B. Concurrent requirements

Not applicable.

C. Reason

Damage to the forward rigid covers when the pilot doors are closed with the latch in the closed position.
Corrosion of aluminum hinges.

D. Compliance

Application of present service bulletin is recommended for AW139 EFS.

E. Description

Addition of a metallic plate on the FWD rigid covers over the aft upper frangible hinge.
Addition of a ply of fiberglass and replacement of hinges.
Addition of a drain hole on the covers.

F. Approval

The technical information contained in this Manufacturer's Service Bulletin was approved by Leonardo Helicopter Division through Engineering Change Notice (ECN 160027).

G. Labour hours

6h per cover (excluding cure time of glue and composite).

H. Weight and balance

The application of this Service Bulletin does not change the maximum allowable weight indicated in the technical specification.

I. Electrical load date

Not applicable.

J. References

This Service Bulletin refers to the ECN (Engineering Change Notice) 160027.

K. Others publications affected

CMM (Component Maintenance Manual) 25-69-56.

L. Family tree charts of modification relationships

Not applicable.

M. Material, cost and availability

Not applicable.

N. Tooling, cost and availability

To carry out the accomplishment instructions specified in this Service Bulletin, tools and materials specified in paragraph 2 are required.

Issue date : JUN 01/18

SB 025-69-13

REV 0
Page 2/14

2. Material Information

A. Material-Product Support Information

1. Material

To apply this Service Bulletin, the following item can be ordered from a local supplier:

- Acetone,
- Isopropyl alcohol,
- Glass Fabric 202gr,
- Resin Araldite LY5052 + Hardener Aradur 5052
- Adhesive EA9309.3NA
- Vacuum film
- Sealing compound MC780B1

To apply this Service Bulletin, the following item must be ordered from ZODIAC AEROSPACE SERVICES:

- 1 L/H metallic plate P/N 226728-0 (for FWD L/H rigid cover),
- 1 R/H metallic plate P/N 226729-0 (for FWD R/H rigid cover),
- 6 Hinge kits P/N 227581-0
- 10 Hinge kits P/N 227582-0

2. Availability

For orders, please contact:
 ZODIAC AEROSPACE SERVICES EUROPE
 61 rue Pierre Curie
 CS20001
 78373 PLAISIR Cedex
 FRANCE
 Tel: (33) (1) 64-34-23-23
 Fax: (33) (1) 64-34-21-08

3. Tooling

- Clamps,
- Wedges,
- Elastomer sheet,
- Medium-grit sand paper P120 (minimum),
- Ø6mm drill bit for composite.

B. Identification Change

Old ASY P/N	Old LDH P/N	Designation	New ASY P/N	New LHD P/N
220980-0	3G9560V03751	FWD LEFT RIGID COVER ASSY	220980-1	3G9560V03752
220981-0	3G9560V03851	FWD RIGHT RIGID COVER ASSY	220981-1	3G9560V03852
220982-0	3G9560V03951	AFT LEFT RIGID COVER ASSY	220982-1	3G9560V03952
220983-0	3G9560V04051	AFT RIGHT RIGID COVER ASSY	220983-1	3G9560V04052

Issue date : JUN 01/18

SB 025-69-13

REV 0
Page 3/14

3. Accomplishment instructions

NOTE: The accomplishment instructions should be carried out in dry premises at temperature within a range of 59°F to 77°F (15°C to 25°C) and a relative humidity below 60%.

NOTE: Procedure is given for the L/H rigid covers. The procedure is symmetrical for the R/H rigid covers.

NOTE: This Service Bulletin can be applied by operators and authorized repair center.

A. Addition of one ply of fiberglass

1. Remove the hinge:

a) Install the container in a stable position and position the holder under the rivet to be removed.

b) Remove the 2 rivets:

- (1) Punch and drill the part of the rod to remove the lock, see Figure 1.
Remove the locking ring.

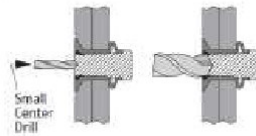

Figure 1

- (2) Chase the center rod if the drilling is not complete, see Figure 2.
Push the central rod using a punch with the correct diameter inside the body of the rivet.

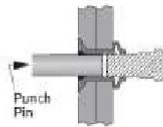

Figure 2

- (3) Drill through the head with a drill diameter slightly less than the nominal diameter of the rivet, see Figure 3.
Be careful to choose a diameter smaller than the diameter of the body of the rivet at the risk of increasing the diameter of the part.

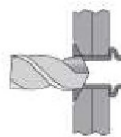

Figure 3

- (4) Remove the head from the rivet using a sharp stem, see Figure 4.
Be careful not to scratch the surface of the part by removing the head from the rivet.

Issue date : JUN 01/18

SB 025-69-13

REV 0
Page 4/14

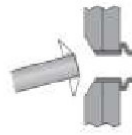

Figure 4

- (5) With a punch of the same diameter as the diameter nominal of the rivet, extract what remains of the body of the rivet, see Figure 5.

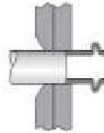

Figure 5

- (6) Check the hole diameter after removal of the rivet.
- c) Using a chisel, gently lift the container hinge.
2. Trace the contour of the area to be repaired using the center of the fixation points of the hinge as a reference, see Figure 6.

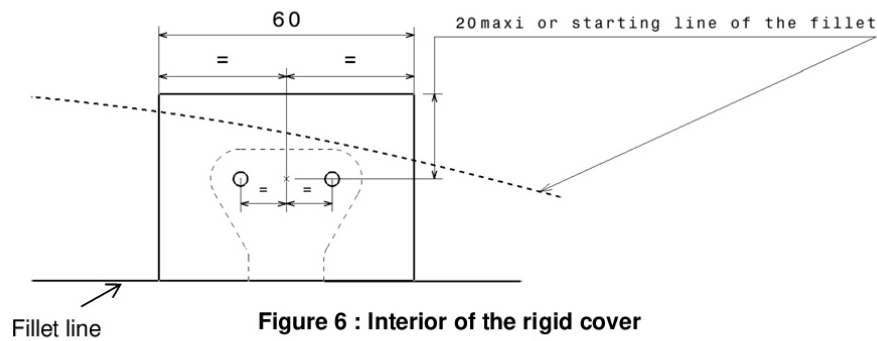

Figure 6 : Interior of the rigid cover

3. Using medium-grit sand paper, sand the area to be repaired on the interior of the rigid cover.
4. Using Acetone, clean the surface to be repaired.
5. Cut ply of glass fabric (60mm x 40 maxi). Adjust the shape and size of the glass fabric to correspond to the size of the sanded area.
6. Prepare the two-component resin as per packaging instructions.
7. Apply the mix of resin on the sanded area.
8. Apply the glass fabric.
9. Apply another layer of resin over the glass fabric making sure the glass fiber is completely covered
10. Cover with a vacuum film to obtain a smooth surface.
11. Clamp to maintain the position.

Issue date : JUN 01/18

SB 025-69-13

REV 0
Page 5/14

12. Let the resin cure as per packaging instructions.
13. Once curing is complete, remove the clamps and the vacuum film
14. Sand lightly to remove any sharp edges on the resin.

B. Drain holes drilling

1. Drill a 6 mm hole in the left FWD rigid cover. Looking at the cover as shown in Figure 7, the centre of hole shall be aligned with the left edge cut of the large bottom foot step opening of the left rigid cover and the centre of the fillet center, see Figure 7, 8 & 9 for drain hole positioning illustration. When installed on the helicopter, the hole shall be in the lowest part of fwd rigid cover.

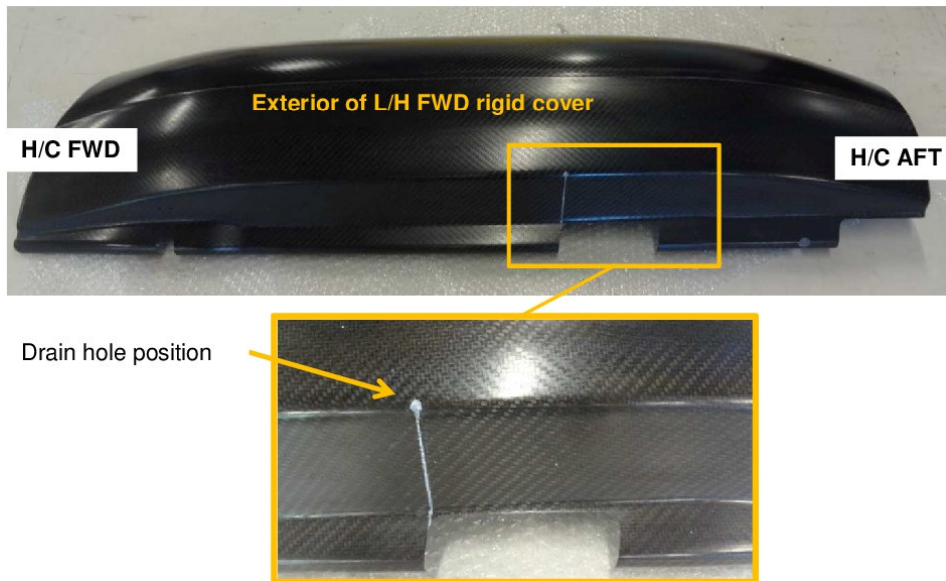

Figure 7 : L/H FWD rigid cover exterior view for drain hole positioning

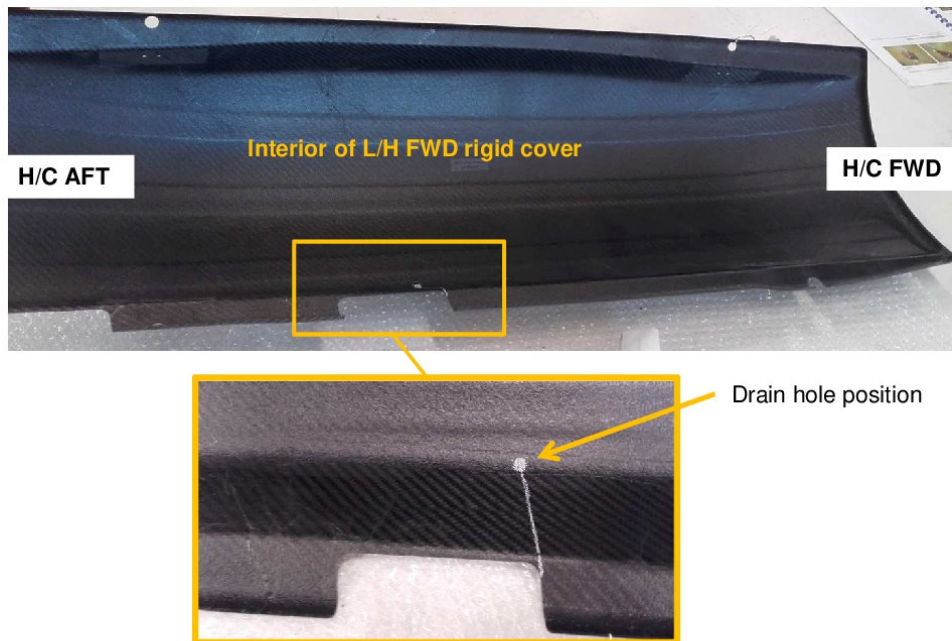

Figure 8 : L/H FWD rigid cover interior view for drain hole positioning

Issue date : JUN 01/18

SB 025-69-13

REV 0
Page 7/14

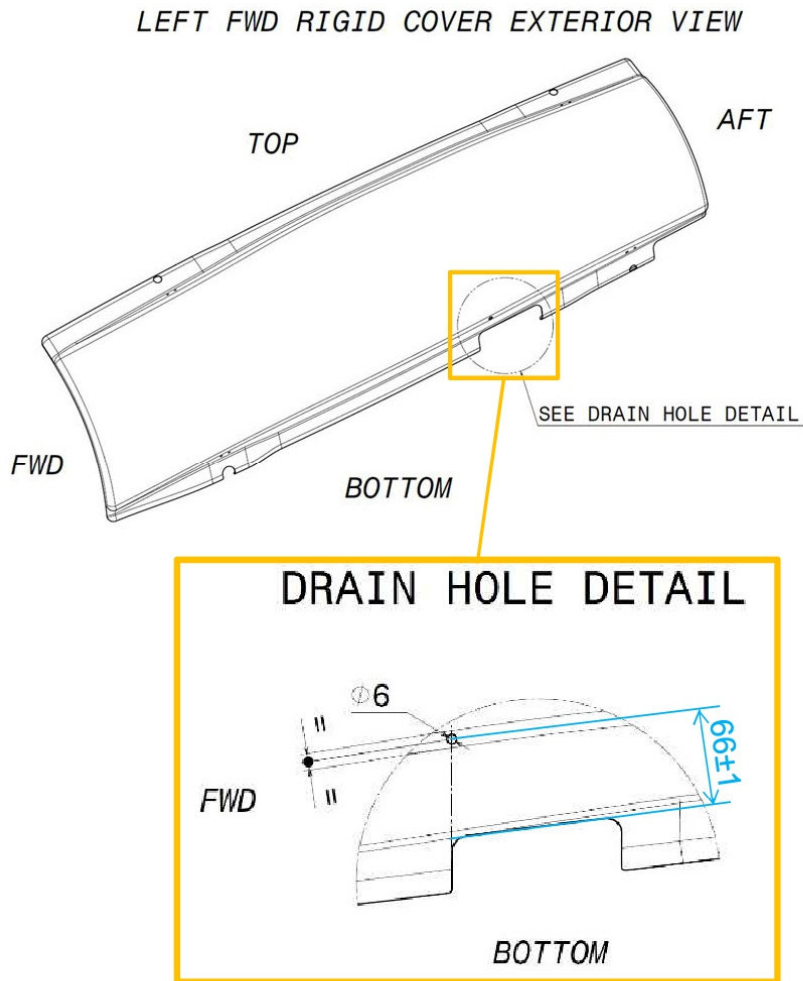

Figure 9 : L/H FWD rigid cover exterior view and drain hole detail, drawing extract

2. Drill the right FWD rigid cover symmetrically to the left FWD rigid cover.

Issue date : JUN 01/18

SB 025-69-13

REV 0
Page 8/14

3. Drill a 6mm hole in the left AFT rigid cover. Looking at the cover as shown in Figure 11, the centre of the hole shall be at 35 mm of the H/C FWD side of the cover edge and 15 mm of the bottom side of the cover edge, see figure 10, 11 & 12 drain hole positioning illustration. When installed on the helicopter, the hole shall be in the lowest part of aft rigid cover.

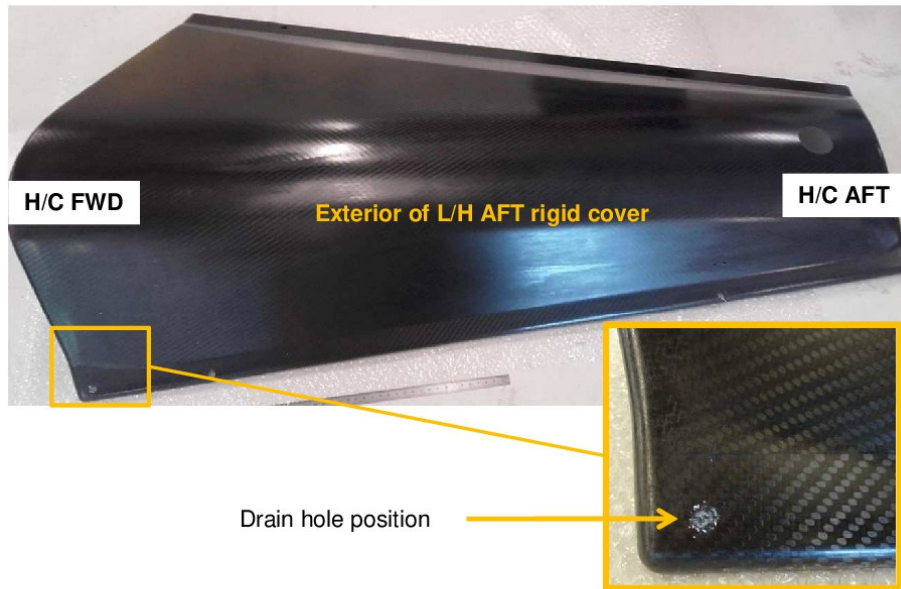

Figure 10 : L/H AFT rigid cover exterior view for drain hole positioning

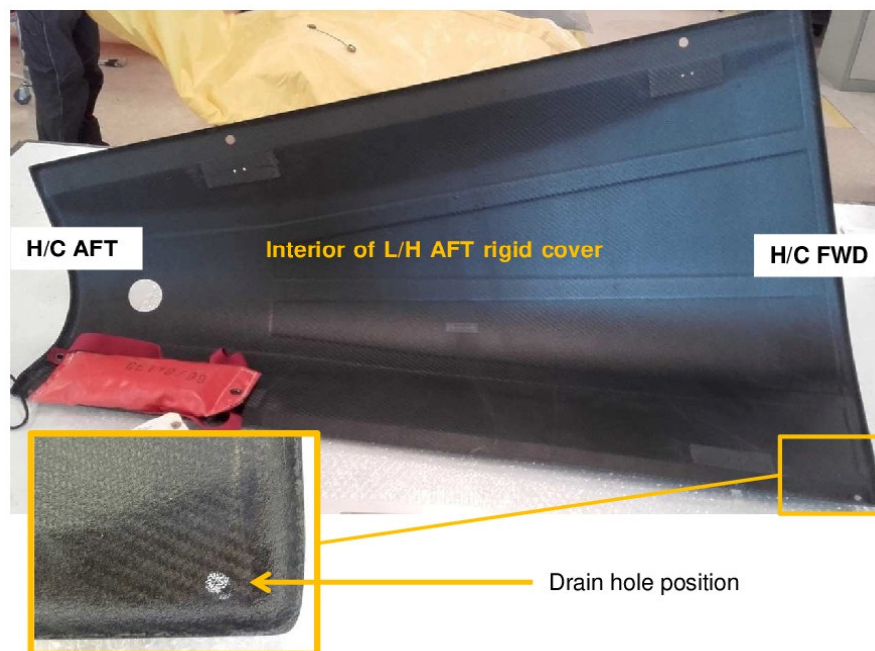

Figure 11 : L/H AFT rigid cover interior view for drain hole positioning

Issue date : JUN 01/18

SB 025-69-13

REV 0
Page 9/14

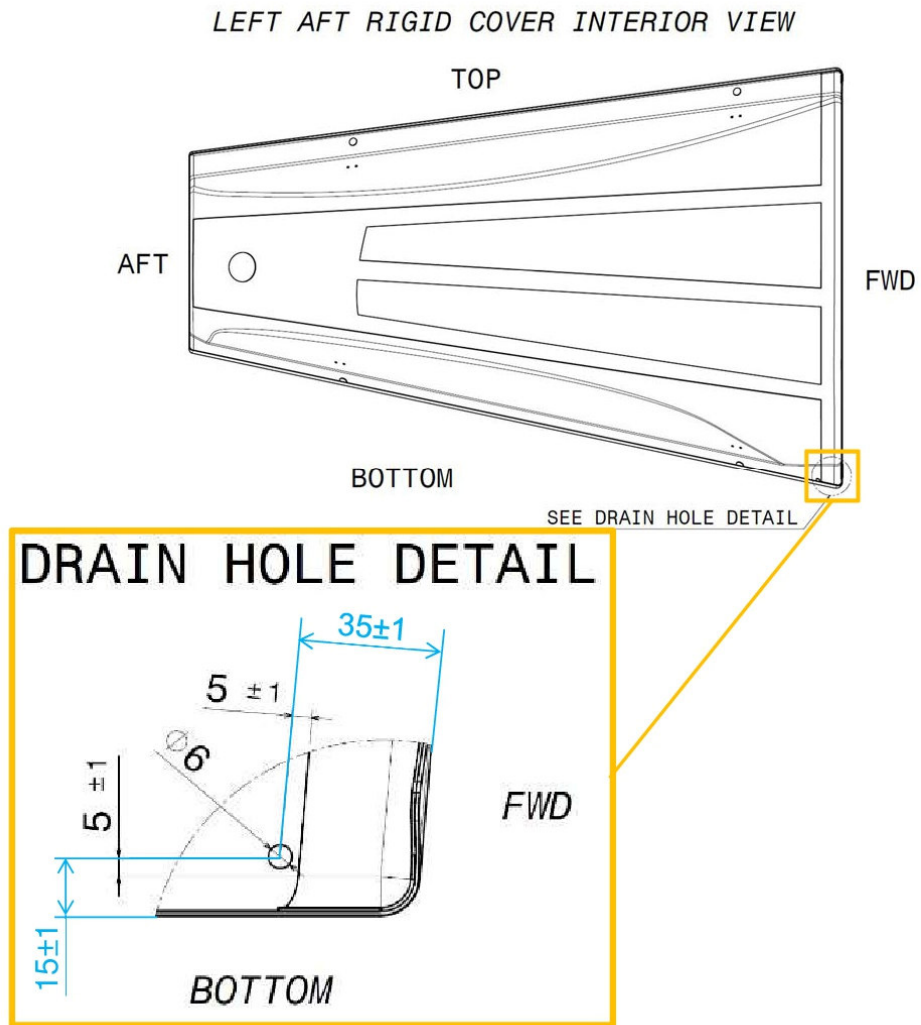

Figure 12 : L/H AFT rigid cover exterior view and drain hole detail, drawing extract

4. Drill the right AFT rigid cover symmetrically to the left AFT rigid cover.

C. Mounting of hinges on rigid covers

1. Place the hinge on the container.
2. Insert the two rivets coated with sealing compound through the hinge.
3. Insert the washer with sealing compound applied on the side in contact with the container side, on the bulb side of the rivet, see Figure 13.

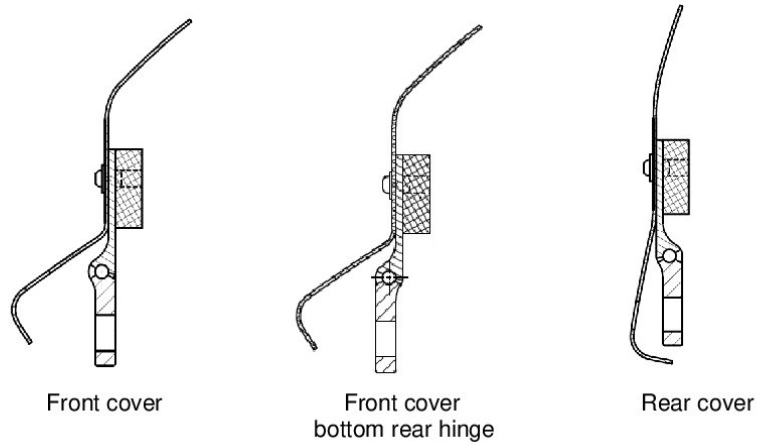

Figure 13

4. Position the washer with a socket, then rivet.

NOTA : Make sure to maintain the rivet perpendicular to the surface of the part during the riveting phase, see Figure 14.

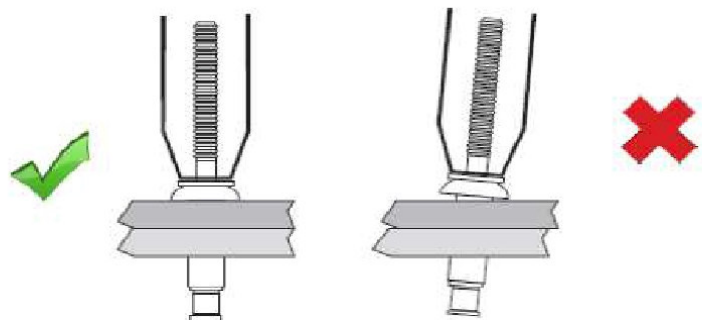

Figure 14

5. As needed, clean with a cloth, the excess sealing compound and adhesive with Acetone. Refer to supplier instruction for sealing compound and adhesive cure time.

Issue date : JUN 01/18

SB 025-69-13

REV 0
Page 11/14

D. Addition of protective plate on forward rigid covers

1. Roughly trace the position of the protective plate
2. Remove any primer and paint applied on the cover in order to properly prepare the surface for metallic bonding.
3. Put the metallic plate over the top AFT hinge of the rigid cover (see Figure 15).

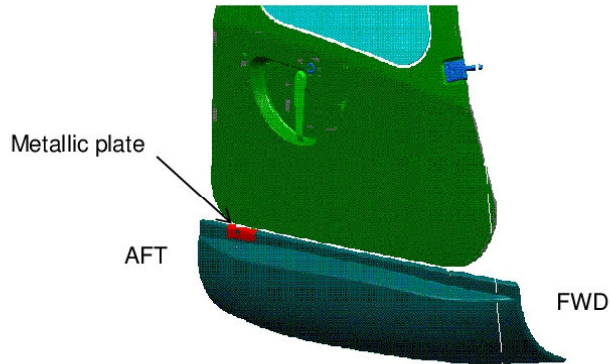

Figure 15

4. Align the hinge access hole of the metallic plate with the one of the rigid cover (see Figure 16).

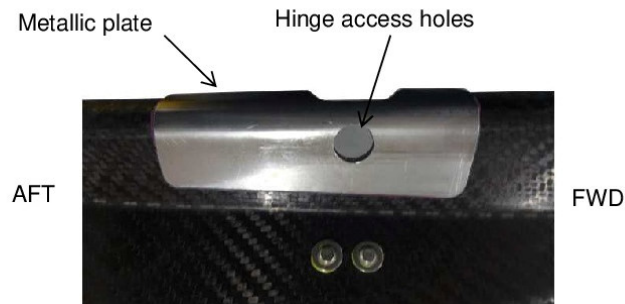

Figure 16

5. Trace the contour of the metallic plate with a white pen.
6. Using medium-grit sand paper, sand the area to be bonded on the rigid cover (see Figure 17).



Figure 17

Issue date : JUN 01/18

SB 025-69-13

REV 0
Page 12/14

7. Using Acetone, clean the surfaces, on the metallic plate and the rigid cover, to be bonded.
8. Prepare the adhesive P/N EA9309.3NA as per packaging instructions.
9. Apply adhesive EA9309.3NA on inner surface of the metallic plate (see Figure 18).



Figure 18

10. Position the metallic plate on the cover (see figure 7). The hinge access hole of the metallic plate with the one of the rigid cover shall be aligned.
11. Position 2 clamps on the ledge of the metallic plate/container as shown on Figure 19.



Figure 19

12. Position 3 clamps on the top of the metallic plate/container as shown on Figures 20. If necessary use a spacer to ensure good clamping.



Figures 20

Note: Check to ensure that the alignment of the hinge access hole on both the metallic plate and cover is still correct.

Issue date : JUN 01/18

SB 025-69-13

REV 0
Page 13/14

13. Remove any excess glue from the contour of the metallic plate using isopropyl alcohol before the curing of the adhesive EA9309.3NA.
14. Let the adhesive cure as per packaging instructions.
15. Once curing is complete, remove the clamps.
16. Primer and paint coating shall be restored (under final customer responsibility). The plate shall remain unpainted.

E. Marking

1. On the marking of the rigid cover, write with permanent black ink, as indicated in Figures 21:
 - SB 025-69-13.
 - Change the ASY (AERAZUR) and the LHD (AGUSTA) P/N to comply with identification change (§ 2.B)



Figures 21

2. Record the work done in the relevant component log card.

Please send to the following address: LEONARDO S.p.A. CUSTOMER SUPPORT & SERVICES - ITALY PRODUCT SUPPORT ENGINEERING & LICENSES DEPT. Via Giovanni Agusta, 520 21017 Cascina Costa di Samarate (VA) - ITALY Tel.: +39 0331 225036 Fax: +39 0331 225988		SERVICE BULLETIN COMPLIANCE FORM		Date:
		Number:		
		Revision:		
Customer Name and Address:		Telephone:		
		Fax:		
		B.T. Compliance Date:		
Helicopter Model	S/N	Total Number	Total Hours	T.S.O.
Remarks:				
Information: We request your cooperation in filling this form, in order to keep out statistical data relevant to aircraft configuration up-to-date. The form should be filled in all its parts and sent to the above address or you can communicate the application also via Technical Bulletin Application Communication Section placed in Leonardo AW Customer Portal - MyCommunications Area. We thank you beforehand for the information given.				