

# Operations and Maintenance Manual

For Ni-Cd Aircraft Batteries



24-30-99  
Dec 02/2022

**saft**

This document and all information contained herein are the property of Saft. Its use is restricted solely to the maintenance of Saft batteries and may under no circumstances be used for any other manufacturer's products. No person may, in whole or in part, duplicate, use or disclose this information for any other purpose without the prior written consent of Saft.



RECORD OF REVISION

Rev no.	Date	Modification
1	Feb 26/2009	23491, 23491-3, 23498-1 added
2	Apr 29/2009	Corrections
3	Aug 07/2009	A275CH1 added, update of flowchart for Periodical Check and General Overhaul
4	Oct 15/2009	276CH10 added
5	Feb 15/2010	272CH1, 40278-14, 345CD1 added
6	Jun 03/2010	539CH2, 437CH14, 2778-2 added
7	Sep 27/2010	Corrections
8	Nov 04/2010	2376-1, 2376-4, 23175, 23176, 4071, 4076, A4078-12 added
9	Mar 04/2011	Corrections
10	Jul 11/2011	435CH6 added
11	Nov 07/2011	4078-11, 4078-12 added
12	Oct 12/2012	2371, 2376, 2708-2, 4071, 4071-1, 4076-9 added
13	Apr 08/2013	Corrections, 4076-1 added
14	Aug 23/2013	4078-14, 4078-19, 4417CH14 added
15	Jan 15/2014	Corrections
16	Apr 11/2014	A4076-21, 2708-2 added and corrections
17	Feb 20/2015	151CH2, 23576-2, 23576-2 added and corrections
18	Jun 01/2015	Corrections
19	Jan 13/2016	Corrections
20	Apr 29/2016	Corrections, 447CH3, 27478 added.
21	Aug 12/2016	Corrections
22	May 16/2017	Corrections, 178CH1, 447CH8 added
23	Aug 03/2018	Corrections, 4076-18 added
24	Mar 04/2019	Corrections
25	Sep 23/2019	Corrections, 5035CH4 added
26	Apr 16/2020	Operation description, disassembly, inspection & check, 407CH9, 4076-9, 12277-2, 40508-1, 181CH1
27	Dec 02/2022	Corrections, 4078-12 removed, global formatting update

PAGE INTENTIONALLY LEFT BLANK

**TABLE OF CONTENTS**

**RECORD OF REVISION** - - - - - PAGE ROR-1

**TABLE OF CONTENTS** - - - - - PAGE TOC-1

**INTRODUCTION** - - - - - PAGE INTRO-1

- 1. General - - - - - PAGE INTRO-1
- 2. Website - - - - - PAGE INTRO-1
- 3. Training courses - - - - - PAGE INTRO-1
- 4. Definitions - - - - - PAGE INTRO-1
- 5. Safety - - - - - PAGE INTRO-2
  - 5-1. Physical - - - - - PAGE INTRO-2
  - 5-2. Electrical - - - - - PAGE INTRO-2
  - 5-3. Chemical - - - - - PAGE INTRO-2
  - 5-4. Battery information sheet - - - - - PAGE INTRO-2
- 6. Aircraft conversions - - - - - PAGE INTRO-2
- 7. Ground applications - - - - - PAGE INTRO-2
- 8. Placing a new battery in service - initial commissioning - - - - - PAGE INTRO-2
- 9. Battery ratings capacity - - - - - PAGE INTRO-3
- 10. Recycling - - - - - PAGE INTRO-3
- 11. End of life cells - - - - - PAGE INTRO-3
- 12. Measurements - - - - - PAGE INTRO-4
  - 12-1. Units of measure - - - - - PAGE INTRO-4
  - 12-2. Multiplying prefixes - - - - - PAGE INTRO-4
  - 12-3. Temperature conversions - - - - - PAGE INTRO-4
  - 12-4. Measurement conversion tables - - - - - PAGE INTRO-5
- 13. Abbreviations - - - - - PAGE INTRO-6

**DESCRIPTION AND OPERATION** - - - - - PAGE 1

- 1. Overview - - - - - PAGE 1
  - 1-1. Batteries - - - - - PAGE 1
  - 1-2. Cells - - - - - PAGE 2
  - 1-3. Connectors - - - - - PAGE 3
- 2. Operation - - - - - PAGE 3
  - 2-1. Climatic requirement - - - - - PAGE 3
  - 2-2. Maintenance - - - - - PAGE 3
- 3. Charge - - - - - PAGE 3
  - 3-1. Constant current charge - - - - - PAGE 4
  - 3-2. Rapid partial charge - - - - - PAGE 4
  - 3-3. Constant potential charge - - - - - PAGE 4
  - 3-4. Other methods of charging - - - - - PAGE 5
  - 3-5. Active stand-by mode (use of a trickle charge) - - - - - PAGE 5

**TESTING AND FAULT ISOLATION** - - - - - PAGE 1001

- 1. Introduction - - - - - PAGE 1001
- 2. Battery electrical faults - - - - - PAGE 1001
- 3. Cell faults - - - - - PAGE 1002
- 4. Physical faults - - - - - PAGE 1003

**DISASSEMBLY** - - - - - PAGE 3001

- 1. Introduction - - - - - PAGE 3001
  - 1-1. General - - - - - PAGE 3001
  - 1-2. Safety - - - - - PAGE 3001
  - 1-3. Job set-up Information - - - - - PAGE 3001
- 2. Disassembly of the battery - - - - - PAGE 3001
  - 2-1. Removal of the cover complete - - - - - PAGE 3001
  - 2-2. Removal of the cell assemblies - - - - - PAGE 3001
  - 2-3. Removal of the liner-spacer kit - - - - - PAGE 3001
  - 2-4. Removal of the one-way valve (if applicable) - - - - - PAGE 3001
  - 2-5. Removal of the power connector complete - - - - - PAGE 3001
  - 2-6. Removal of the sensor connector complete (if applicable) - - - - - PAGE 3002

## TABLE OF CONTENTS

<b>CLEANING</b> - - - - -	<b>PAGE 4001</b>
1. Introduction - - - - -	PAGE 4001
2. Safety - - - - -	PAGE 4001
3. Equipment - - - - -	PAGE 4001
3-1. Standard tools - - - - -	PAGE 4001
3-2. Special tools - - - - -	PAGE 4001
3-3. Consumables - - - - -	PAGE 4001
4. Light cleaning - - - - -	PAGE 4001
4-1. Procedure - - - - -	PAGE 4001
4-2. Lubrication - - - - -	PAGE 4001
5. Thorough cleaning - - - - -	PAGE 4001
5-1. Procedure - - - - -	PAGE 4001
5-2. Lubrication - - - - -	PAGE 4002
<b>INSPECTION/CHECK</b> - - - - -	<b>PAGE 5001</b>
1. Introduction - - - - -	PAGE 5001
2. Maintenance intervals - - - - -	PAGE 5001
2-1. Periodical check - - - - -	PAGE 5001
2-2. Regular check - - - - -	PAGE 5001
2-3. General overhaul - - - - -	PAGE 5001
3. Recording - - - - -	PAGE 5001
4. Safety - - - - -	PAGE 5001
5. Equipment - - - - -	PAGE 5001
5-1. Standard tools - - - - -	PAGE 5001
5-2. Special tools - - - - -	PAGE 5001
6. Periodical check - - - - -	PAGE 5002
6-1. Visual inspection - - - - -	PAGE 5003
6-2. Insulation check - - - - -	PAGE 5003
6-3. Nut tightness - - - - -	PAGE 5004
6-4. Open circuit voltage check - - - - -	PAGE 5004
6-5. Polarization test - - - - -	PAGE 5004
6-6. Residual discharge - - - - -	PAGE 5004
6-7. Adjust electrolyte level - - - - -	PAGE 5004
6-8. Supplementary test - - - - -	PAGE 5005
7. Regular check - - - - -	PAGE 5006
7-1. Cell shorting - - - - -	PAGE 5007
7-2. Capacity check - - - - -	PAGE 5007
8. General overhaul - - - - -	PAGE 5008
8-1. Component inspection - - - - -	PAGE 5009
8-2. Replacement of faulty components - - - - -	PAGE 5009
8-3. Sensor check - - - - -	PAGE 5009
8-4. Vent-valve test - - - - -	PAGE 5018
<b>ASSEMBLY</b> - - - - -	<b>PAGE 7001</b>
1. Introduction - - - - -	PAGE 7001
2. Safety - - - - -	PAGE 7001
3. Equipment - - - - -	PAGE 7001
3-1. Standard tools - - - - -	PAGE 7001
3-2. Special tools - - - - -	PAGE 7001
4. Battery assembly - - - - -	PAGE 7001
4-1. Installation of the sensor connector complete (if applicable) - - - - -	PAGE 7001
4-2. Installation of the power connector complete - - - - -	PAGE 7001
4-3. Installation of the one-way valve (if applicable) - - - - -	PAGE 7002
4-4. Installation of the liner-spacer kit - - - - -	PAGE 7002
4-5. Installation of the cell assembly - - - - -	PAGE 7002
4-6. Installation of the cover complete - - - - -	PAGE 7002
4-7. Recording - - - - -	PAGE 7002
<b>FITS AND CLEARANCES</b> - - - - -	<b>PAGE 8001</b>
1. Introduction - - - - -	PAGE 8001
2. Power connector types - - - - -	PAGE 8001
3. Battery specifications - - - - -	PAGE 8002
4. Vent-valve torque data - - - - -	PAGE 8015
5. BAC102 power connector torque table - - - - -	PAGE 8015

TABLE OF CONTENTS

**SPECIAL TOOLS, FIXTURES, EQUIPMENT AND CONSUMABLES - - - - - PAGE 9001**

- 1. Introduction - - - - - PAGE 9001
- 2. Standard tools - - - - - PAGE 9001
- 3. Special tools - - - - - PAGE 9002
  - 3-1. Special tool list - - - - - PAGE 9002
  - 3-2. Special tool kits - - - - - PAGE 9002
- 4. Consumables - - - - - PAGE 9005

**ILLUSTRATED PARTS LIST - - - - - PAGE 10001**

- 1. Description - - - - - PAGE 10001
- 2. Battery parts list- - - - - PAGE 10004
  - 2-1. BAC102 power connector assembly - - - - - PAGE 10012
- 3. Inter-cell connections - - - - - PAGE 10012
  - 3-1. Inter-cell connections parts list - - - - - PAGE 10012
  - 3-2. Battery connection layouts - - - - - PAGE 10018
- 4. Cell assembly parts list - - - - - PAGE 10024
- 5. Sensor connector covers - - - - - PAGE 10026

**STORAGE (INCLUDING TRANSPORTATION) - - - - - PAGE 15001**

- 1. Introduction - - - - - PAGE 15001
  - 1-1. General - - - - - PAGE 15001
  - 1-2. Storage room - - - - - PAGE 15001
  - 1-3. Climatic conditions - - - - - PAGE 15001
- 2. Storage - - - - - PAGE 15001
  - 2-1. Inactive long-term storage - - - - - PAGE 15001
  - 2-2. Inactive standby storage - - - - - PAGE 15001
- 3. Storage of spare parts- - - - - PAGE 15004
  - 3-1. Spare cell assemblies - - - - - PAGE 15004
  - 3-2. Spare O-rings, gaskets, and vent-valves assemblies - - - - - PAGE 15004
- 4. Transportation procedure - - - - - PAGE 15004

PAGE INTENTIONALLY LEFT BLANK



## INTRODUCTION

### 1. General

This manual provides the information necessary for an experienced shop technician to maintain Saft Nickel-Cadmium (Ni-Cd) batteries. It describes the construction of the battery as well as the techniques used to operate, maintain, overhaul, and generally care for the battery. Following these instructions will make sure of optimal performances and life of the Saft batteries.

All aircraft batteries require checking and maintenance in order to make sure they are safe when installed and perform their required functions, especially in emergency conditions on board the aircraft. Maintenance permit to identify and correct any issues to be identified. Proper battery maintenance assures a low probability of failure. It achieves high levels of MTBUR and MTBF. Failure prevention on board the aircraft make sure of safe operation, reduces delays and operational costs.

Every effort has been made to provide complete and accurate instructions. If a situation should arise that is not adequately described in this manual, please contact Saft via the Internet at [www.saftbatteries.com](http://www.saftbatteries.com) or at one of the following addresses:

**Saft America Inc. (09052)**  
 711 Gil Harbin Industrial Boulevard  
 Valdosta, Georgia 31601 - USA  
 Tel: +1 (229) 247-2331  
 Fax: +1 (229) 247-8486



**Saft (F6177)**  
 26 quai Charles Pasqua  
 92300 Levallois-Perret - France  
 Tel: +33 1 58 63 16 00  
 Fax: +33 1 58 63 16 18



Saft manufactures a wide range of batteries for aircraft applications. These batteries vary in size, weight, capacity and/or electrical performance to fit the specific requirements of the application. The Specification tables in [FITS AND CLEARANCES](#) chapter list the basic specifications for the Saft batteries covered by this manual. For information on Saft batteries not listed here, contact your local Saft representative.

**NOTE: Some Saft batteries have a specific Component Maintenance Manual (CMM) assigned to them. If a CMM exists, that information will supersede the contents of this manual for that particular battery type and this document will become supplemental. Contact a Saft representative, or check the Saft website at <https://saft4u.saftbatteries.com> for a complete listing of available Component Maintenance Manuals.**

### 2. Website

All Saft technical documentation, distributors and repair shops can be found on [www.saftbatteries.com](http://www.saftbatteries.com).

Technical documentation for Saft Ni-cd aviation batteries is available on <https://saft4u.saftbatteries.com>.



[www.saftbatteries.com](http://www.saftbatteries.com)



<https://saft4u.saftbatteries.com>

### 3. Training courses

Saft offers training courses for Ni-Cd battery maintenance at Saft training centers, at customer premises, and in an eLearning format. All information is available online at <https://www.saftbatteries.com/market-sectors/aerospace-defense/aviation>. For registration to Saft trainings, please log in to the Saft4U portal at <https://saft4u.saftbatteries.com>.



<https://www.saftbatteries.com/market-sectors/aerospace-defense/aviation>

### 4. Definitions

**WARNING: WARNINGS ADVISE TO USE OF MATERIALS, PROCEDURES, OR LIMITS, WHICH MUST BE FOLLOWED PRECISELY TO AVOID PERSONAL INJURIES, OR EFFECT SAFETY OF FLIGHT.**

**CAUTION: CAUTIONS CALL ATTENTION TO PROCEDURES WHICH MUST BE FOLLOWED TO AVOID DAMAGE TO EQUIPMENT OR PARTS.**

**NOTE: Notes call attention to procedures which make the job easier.**

## INTRODUCTION

## 5. Safety

**CAUTION: EXCEPT FOR THOSE STEPS THAT REQUIRE THE BATTERY TO BE CHARGED, DO ALL STEPS ON DISCHARGED BATTERIES (REFER TO [Residual discharge](#) PARAGRAPH) TO AVOID THE POSSIBILITY OF ELECTRIC SHOCK. TIGHTEN VENT-VALVES BEFORE THE START OF THE DISCHARGE. BATTERY CELLS DELIVER VERY HIGH CURRENT WHEN SHORT-CIRCUITED. BE CAREFUL. REMOVE RINGS, WATCHES, NECKLACES, METALLIC BELTS OR OTHER JEWELRY TO AVOID ELECTRIC SHOCK.**

**CAUTION: DO NOT TILT THE BATTERY WHILE DOING MAINTENANCE, ANY CONTACT OF SKIN WITH ELECTROLYTE CAN CAUSE SEVERE BURNS.**

Local safety regulations should be followed as safety regulations are country-dependent.

There are three types of risks:

### 5-1. Physical

- Handling: the batteries are heavy. Use proper technique when lifting heavy loads. Bend your legs and not your back.
- Wear protective shoes.

### 5-2. Electrical

- Do not wear rings, watches, chains, belt buckles, necklaces or any other conductive objects.
- Use insulated tools.

### 5-3. Chemical

- Electrolyte is very corrosive and can damage the skin. Use proper personal protective equipment (PPE) such as gloves and an apron. If it touches the skin, flush affected area with large quantities of water. After flushing begins, remove all contaminated clothing.
- Electrolyte is very dangerous to the eyes, use protective goggles. If the electrolyte comes in contact with the eyes, flush with water for 15 to 30 minutes and get immediate medical aid.
- Saft recommends the use of an amphoteric solution (both acidic and basic behavior) and chelator (able to trap cations as a chelate complex) to neutralize electrolyte according to the local regulation.

### 5-4. Battery information sheet

For a complete listing of hazards, refer to the Battery Information Sheet (BIS) available on Saft's website at <https://saft4u.saftbatteries.com>. The document is also accessible by scanning the QR code below.



Battery information sheet

## 6. Aircraft conversions

Saft Ni-Cd aircraft batteries come in a wide variety of configurations that are approved for installation on selected aircraft. When replacing a lead-acid battery with a Saft Ni-Cd aircraft battery, it is vitally important to clean all mounting and holding fixtures in the aircraft before installation. All traces of acid and salt should be removed by washing with a neutralizing agent such as sodium bicarbonate (baking soda) in water. When the area has been fully cleaned and prepared, paint the surface with an alkaline resistant paint. This preparation makes sure that your new Saft battery will not be harmed by sulfuric acid residue.

## 7. Ground applications

Saft batteries can be used in ground applications for starting gas turbine generators, powering ground mobile equipment, or in shop testing equipment. The same principles used in flight operations apply when the battery is used in ground applications. Ventilation of the battery during ground use can be accomplished through a ventilation system or by simply removing the cover (only in a well-ventilated area). Check with your local authorities for regulations in effect.

## 8. Placing a new battery in service - initial commissioning

**NOTE: Whether or not the battery has been subject to disassembly and reassembly, before to issue in service and installation certificate, check the tightness of all upper nuts to verify that torque values correspond with those specified (refer to chapter [Nut tightness](#)).**

Before installation of the battery into the aircraft for service:

- If initial commissioning is performed within 12 months then do [Visual inspection](#), [Insulation check](#), [Nut tightness](#), [Charge](#) [Adjust electrolyte level](#), and repeat [Insulation check](#).
- If initial commissioning is performed after 12 months, do [Charge](#) and [Regular check](#).
- Starting date for this period is the date of manufacturing (DMF).

## INTRODUCTION

## 9. Battery ratings capacity

Ni-Cd batteries are rated in terms of capacity in ampere-hours (Ah) (rated capacity).

American Standard AS8033 defines capacity as "the dischargeable ampere-hours (Ah) available from a fully charged cell/battery at any specified discharge rate/temperature condition."

Other definitions for battery ratings can be found in EN2570, IEC 60952, and RTCA DO293A.

A battery rated for  $1C_1$  Ah indicates that the battery is rated at a value based upon a discharge time of 1 hour at  $+23\text{ }^\circ\text{C} \pm 3\text{ }^\circ\text{C}$  ( $+73.4\text{ }^\circ\text{F} \pm 5.4\text{ }^\circ\text{F}$ ) when new.

A typical discharge curve for Saft VHP series cells can be found in figure [INTRO-1 - Discharge curve for VHP series cells](#).

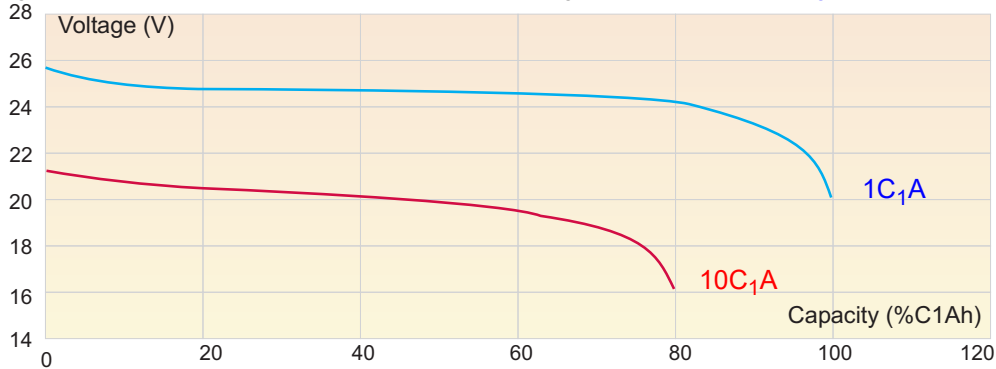

Figure INTRO-1 - Discharge curve for VHP series cells

## 10. Recycling

All batteries eventually lose their ability to perform and are eligible for scrapping and recycling. Saft takes environmental matters seriously and advocates proper recycling of Ni-Cd batteries and their components. To that end, Saft operates recycling facilities worldwide.

Ni-Cd batteries contain nickel, cadmium, and potassium hydroxide and should be disposed of properly. In all cases, rely on local and national regulations for proper battery disposal and/or shipping to an appropriate recycling location.



Figure INTRO-2 - Universal recycling symbols

The nearest recycling collection point can be found on <https://www.saftbatteries.com/about-us/manufacturing-our-batteries/our-sustainability-global-approach>. A document containing a list of collection points is also accessible by scanning the QR code below.



Recycling collection points

## 11. End of life cells

EASA regulations 'Part 145', require that end of life cells must be disposed of in a manner that does not allow them to be returned to service. The following procedure provides a means of complying with these regulations. While other authority requirements (such as FAA) may be less explicit, Saft recommends that the following procedures be adopted.

In order to ensure that end of life cells cannot be re-used, the following procedure is recommended:

- Ensure that appropriate protective measures (refer to [Safety](#) paragraph) and BIS are taken.
- Ensure that the cell is fully discharged (refer to [Cell shorting](#) paragraph).
- Put one of the terminals from the cell between the two sides of a bench vice and bend until the terminal breaks. In the event of electrolyte leakage, ensure that appropriate clean up measures as described in the BIS are observed.
- Dispose of the cell in accordance with applicable transport, health and safety and recycling regulations (Refer to [Recycling](#) paragraph).

## INTRODUCTION

**12. Measurements**

The measurements given in this manual come from the original manufacturer drawings.

This document uses the International System (SI) of units for quantities and values. Additionally, US Imperial units are given in parenthesis.

**12-1. Units of measure****12-1-1. SI units**

A	Ampere
Ah	Ampere hours
Bar	Bar
C <sub>1</sub> A	Rated current
C <sub>1</sub> Ah	Rated capacity for an hour
cm <sup>3</sup>	Centimeter cube
g	Gram
m	Meter
min	Minute
N	Newton
N.m	Newton meter
Pa	Pascal
V	Voltage
V <sub>DC</sub>	Volt direct current
°C	Degree Celsius
%	Per cent
Ω	Ohm
μS/cm	Micro-Siemens per centimeter

**12-1-2. US Imperial units**

ft	Foot
in	Inch
in.Hg	Inch of Mercury
lb	Pound
lbf.in	Pound force inch
psi	Pound per square inch
°F	Degree Fahrenheit

**12-2. Multiplying prefixes**

da	Deca
h	Hecto
k	Kilo
M	Mega
m	Milli
μ	Micro

**12-3. Temperature conversions****12-3-1. From degrees Fahrenheit (°F) to degrees Celsius (°C)**

Celsius = (Fahrenheit - 32) x 0.5555

**12-3-2. From degrees Celsius (°C) to degrees Fahrenheit (°F)**

Fahrenheit = (Celsius x 1.8) + 32

## INTRODUCTION

## 12-4. Measurement conversion tables

## 12-4-1. From SI unit to US Imperial unit

1 Bar	14.504 psi
1 cm	0.3937 in
1 cm <sup>2</sup>	0.1550 in <sup>2</sup>
1 cm <sup>3</sup>	0.06 in <sup>3</sup>
1 g	0.0353 oz
1 g/l	0.000578 oz/in <sup>3</sup>
1 hPa	0.01450 psi
1 kg	2.2046 lb
1 kg/l	0.578 oz/in <sup>3</sup>
1 mm	0.0394 in
1 N	0.2248 lbf
1 N.m	8.8507 lbf.in

## 12-4-2. From US Imperial unit to SI unit

1 gal (U.S.)	3.7854 l
1 in	2.54 cm
1 in	25.4 mm
1 in <sup>2</sup>	6.4516 cm <sup>2</sup>
1 in <sup>3</sup>	16.4 cm <sup>3</sup>
1 in.Hg	33.864 hPa
1 lb	0.4536 kg
1 lbf	4.4482 N
1 lbf.in	0.1130 N.m
1 lbf.ft	1.3558 N.m
1 oz	28.3495 g
1 oz/in <sup>3</sup>	1,771.25 g/l
1 oz/in <sup>3</sup>	1.771 kg/l
1 psi	68.948 hPa
1 psi	0.0689 Bar

## INTRODUCTION

**13. Abbreviations**

The abbreviations given below are used in this manual:

APU	Auxiliary Power Unit
ASD	AeroSpace and Defence Industries Association of Europe
ATA	Air Transport Association of America
BIS	Battery Information Sheet
DC	Direct current
DMF	Date of Manufacturing
EASA	European Air Safety Authority
FAA	Federal Aviation Authority
fig.	figure
IATA	International Transport Air Association
IEC	International Electrotechnical Commission
IMDG	International Maritime Dangerous Goods
IPL	illustrated parts list
MTBF	Mean Time Between Failure
MTBUR	Mean Time Between Unscheduled Removal
Ni-Cd	Nickel-Cadmium
OMM	Operations Maintenance Manual
P/N	part number
PPE	Personal Protective Equipment
RTCA	Radio Technical Commission for Aeronautics
SI	International System of Unit

## DESCRIPTION AND OPERATION

### 1. Overview

The batteries are connected to the aircraft system:

- According to the aircraft manufacturer, to start the engine or the APU.
- On the ground, to provide power before electrical power is supplied to the aircraft systems.
- In flight, if a malfunction or a failure occurs in the power supply system.

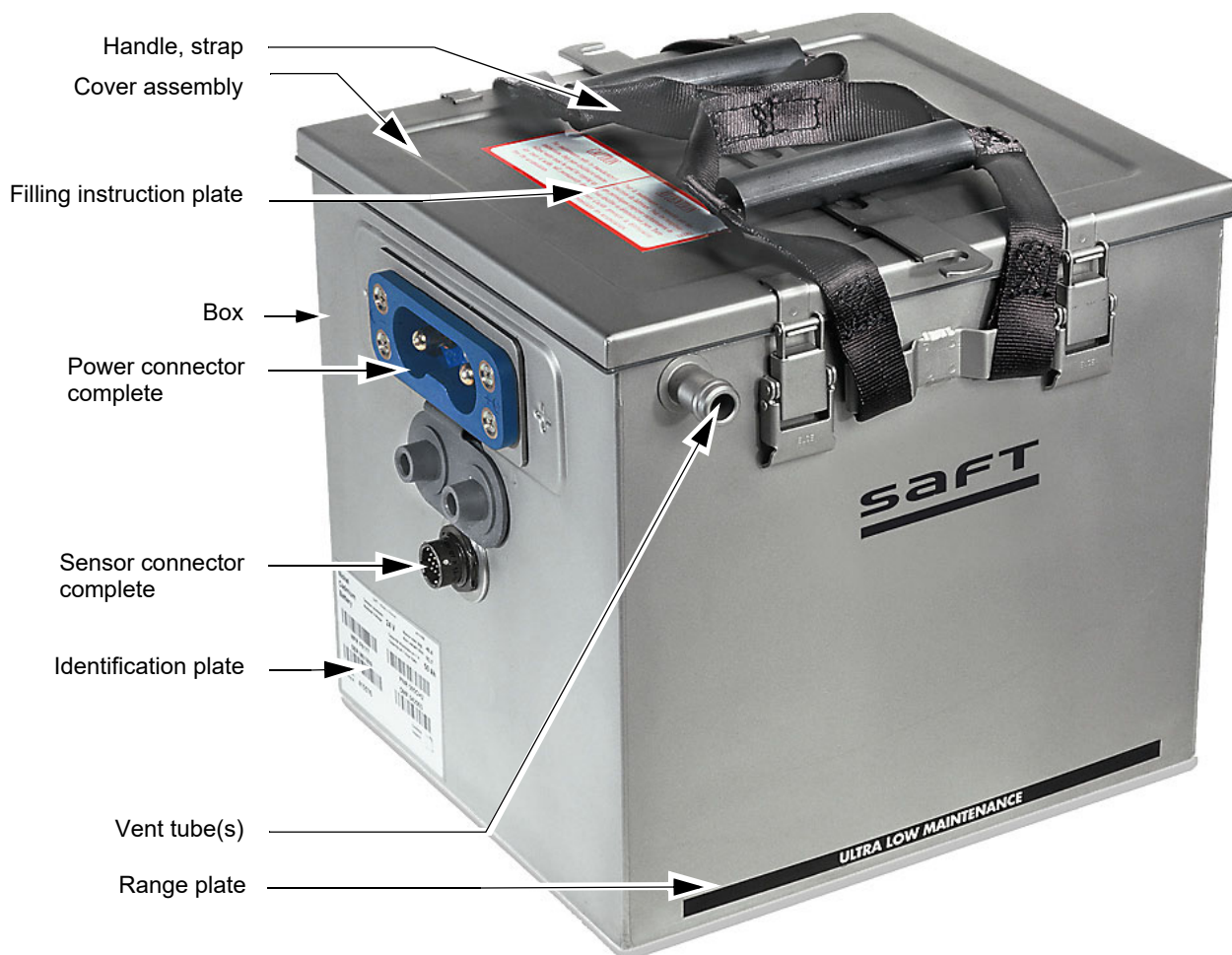

**Figure 1 - Ni-Cd aircraft battery**

#### 1-1. Batteries

**NOTE:** The item numbers are those of IPL figure [10001 - Ni-Cd aircraft battery](#).

Each Saft Ni-Cd battery consists of a metallic box assembly (020), usually stainless steel, plastic-coated steel, painted steel or titanium, containing a number of individual cell assemblies (100). These cells are connected in series to obtain a specified voltage, usually 12 or 24 volts nominal. Individual cells are enclosed in a polyamide container that provides insulation, allowing them to be fitted side-by-side in the battery box. Cells are interconnected with rigid, highly conductive, nickel-plated copper links (030 to 095). Each link is held in position by spring washers (120) and nickel-plated copper nuts (110 and 115) on the cells' terminals (or nickel-plated steel bolts for internally threaded terminals). Inside the battery box assembly, individual cells are held in position by a liner-spacer kit (200) and a cover complete (010). Each battery is designed with appropriate ventilation to allow the escape of gases produced during an overcharge condition.

## DESCRIPTION AND OPERATION

## 1-2. Cells

The cell assembly (100) is the active component of the battery. This is where the electrochemical reaction occurs that converts chemical energy into electricity. In Saft aviation batteries, the design features are on the cutting edge of today's technology.

The active elements of the Ni-Cd cell are either two groups of thin, porous, sintered nickel plates (VO, VP, VXP & Delta Plus (VHP) Series) or one group of positive sintered nickel plates and one group of negative Plastic Bonded Electrode (PBE) plates [ULM<sup>®</sup> Series (CVH, CVK, CVD)]. In all cells, the positive plates are sintered nickel, impregnated with nickel-hydroxide. The negative plates are either sintered nickel impregnated with cadmium-hydroxide, or cadmium-oxide applied in a non-sintered coating process (PBE), which is later converted to cadmium-hydroxide during manufacturing. In the cell, the positive and negative plates are immersed in electrolyte, a solution of potassium hydroxide and water.

Within the cell container, a three-part separator separates the plates of opposite polarity. The outer layers are a felt-like fabric. This fabric allows the electrolyte to stay in contact with the plates by "wicking". The inner layer is either an organic or a micro-porous synthetic material that acts as a gas barrier to control oxygen recombination during recharge.

Each set of positive and negative plates is connected to a plate tab that employs a continuous welding joint for maximum energy transfer. These terminals are connected to the respective terminal posts. The terminal post is what allows external connections to be made. An O-ring seals the terminals.

Each cell is equipped with a vent-valve that can be removed to allow access to the electrolyte (for the addition of distilled or deionized water). This valve also serves as a pressure-checking device, designed to limit the pressure inside the cell to 70,000 Pa (10 psi) maximum.

Many cells have a raised edge surrounding the vent-valve to contain any minor release of electrolyte that may occur during overcharge.

Saft cells are composed of a cover and body made of polygamy plastic. These are thermally welded together to form a single, leak proof container. This ensures that if the battery is maintained and used under normal circumstances, it will never leak.

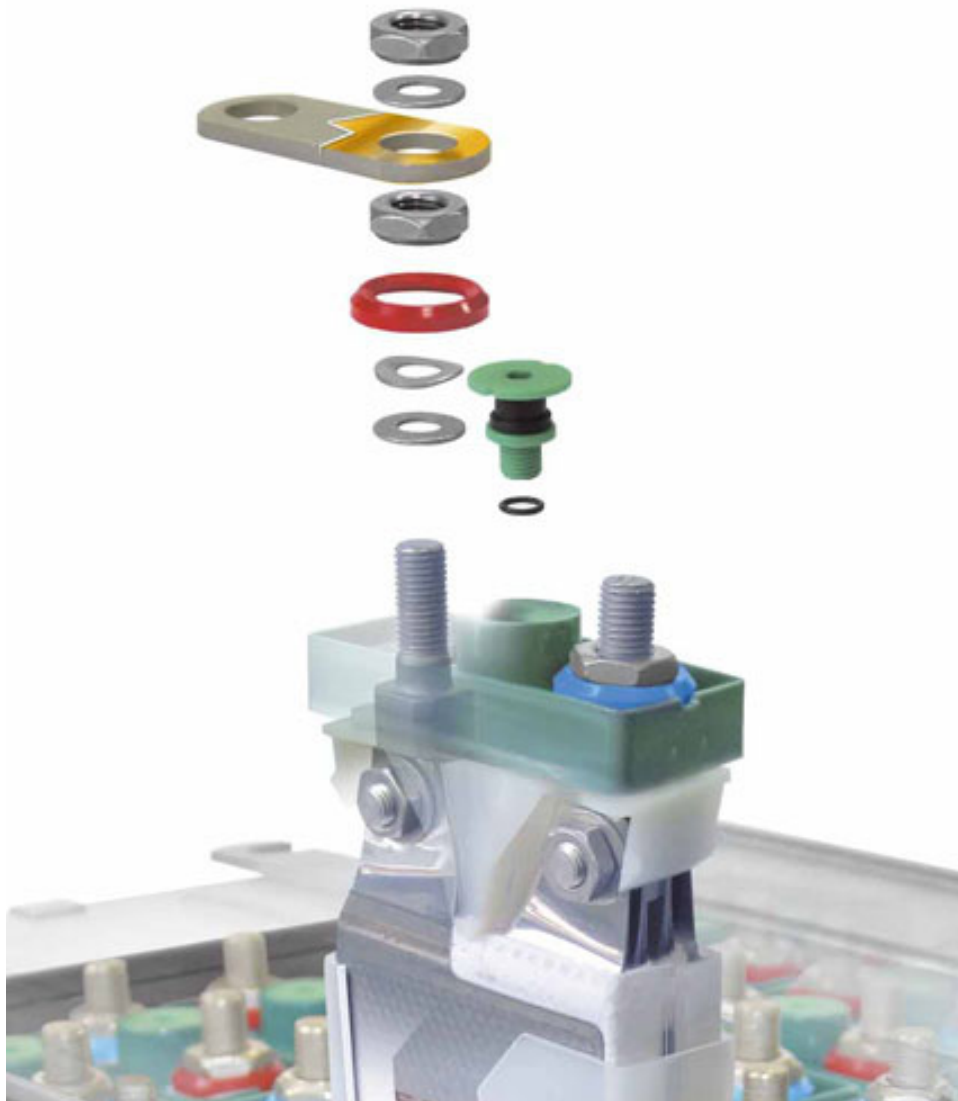

Figure 2 - Cutaway of a vented cell



## DESCRIPTION AND OPERATION

## 1-3. Connectors

Each Saft battery is connected to the aircraft by either a standard main power connector complete (230), such as an MS3509 type, or a special power connector complete (230) as specified by the aircraft manufacturer. Refer to “[FITS AND CLEARANCES](#)” to determine the connector used on the batteries covered by this manual.

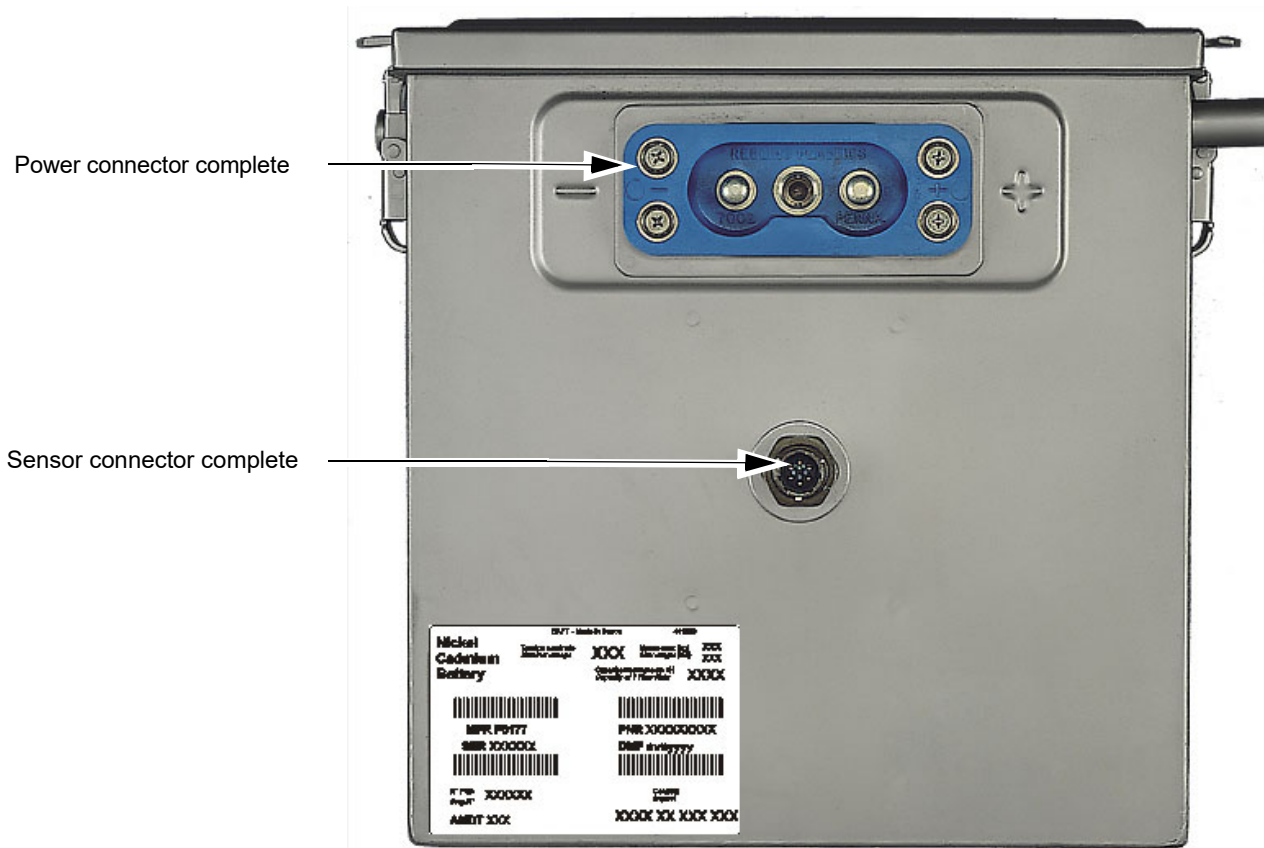

Figure 3 - Battery connectors

## 2. Operation

## 2-1. Climatic requirement

Although Saft Ni-Cd batteries are capable of operating in a wide temperature range  $-40^{\circ}\text{C}$  ( $-40^{\circ}\text{F}$ ) and  $+71^{\circ}\text{C}$  ( $+160^{\circ}\text{F}$ ), optimum performance is reached between  $+5^{\circ}\text{C}$  ( $+41^{\circ}\text{F}$ ) and  $+45^{\circ}\text{C}$  ( $+113^{\circ}\text{F}$ ). Charging is inefficient at temperatures below  $-30^{\circ}\text{C}$  ( $-22^{\circ}\text{F}$ ) and is not recommended above  $+57^{\circ}\text{C}$  ( $+135^{\circ}\text{F}$ ). Charging must be stopped at temperatures above  $+71^{\circ}\text{C}$  ( $+160^{\circ}\text{F}$ ).

Unless otherwise stated, charge and discharge testing should be done when:

- The battery temperature is between  $+15^{\circ}\text{C}$  ( $+59^{\circ}\text{F}$ ) and  $+35^{\circ}\text{C}$  ( $+95^{\circ}\text{F}$ ).
- Pressure 750 to 1060 hPa (22.15 to 31.3 in.Hg).
- Relative humidity  $< 85\%$ .

## 2-2. Maintenance

All maintenance, including charging, discharging, should be done specifically in accordance with the instructions contained in this manual or a corresponding Component Maintenance Manual (CMM). If a CMM exists for a battery, that information will supersede the contents of this manual and this OMM will become supplemental.

## 3. Charge

The charge, also named maintenance charge, is done in 2 steps:

- Step 1: called “charge” or “main charge”, is a constant current charge with three possible charge rates
- Step 2: called “overcharge” or “final charge”, is also a constant current charge with only one possible charge rate

Other charging methods, restricted to the use of the battery, are described in following paragraphs. They cannot be used for maintenance described in this OMM.

## DESCRIPTION AND OPERATION

## 3-1. Constant current charge

**NOTE: Check cell voltage at the beginning of the charge. If any cell indicates an immediate voltage rise above 1.5 V, add 5 cm<sup>3</sup> (0.3 in<sup>3</sup>) of distilled or deionized water to that cell.**

**NOTE: Always apply the main charge for no less than the minimum duration.**

Starting with a discharged battery:

- Remove the cover complete (010).
- Loosen, but do not remove, all vent-valve assemblies (160).
- Remove power connector complete (230) cover -if present-
- Charge using one of the methods shown in the table below main charge (step 1).
- After the minimum duration is reached, measure the voltage on each cell and compare the values with the criteria in the table below.
- During the last 15-30 minutes of the final charge cycle (step 2), Adjust electrolyte level (refer to [Adjust electrolyte level](#)).

Charge of the battery				
Main Charge (step 1)			Final Charge (step 2)	
Current	Minimum duration	End of main charge criteria	Current and time	Minimum voltage criteria
0.1C <sub>1</sub> A*	10 hours	Every cell > 1.5 V or 12 hours which ever comes first	0.1C <sub>1</sub> A for 4 hours	1.5 V/cell for VO/VP/VHP/VXP 1.55 V/cell for CVH/CVD/CVK
0.5C <sub>1</sub> A	2 hours	Every cell > 1.55 V or 2 hours 30 min which ever comes first	0.1C <sub>1</sub> A for 4 hours	1.5 V/cell for VO/VP/VHP/VXP 1.55 V/cell for CVH/CVD/CVK
1C <sub>1</sub> A	1 hour	Every cell > 1.57 V or 1 hour 15 min which ever comes first	0.1C <sub>1</sub> A for 4 hours	1.5 V/cell for VO/VP/VHP/VXP 1.55 V/cell for CVH/CVD/CVK

Table 1 - Battery charge

(\*) Low charge rate 0.1 C<sub>1</sub>A is suggested after cell shorting.

For example, during the main charge (step 1) at 1C<sub>1</sub>A for 1 hour:

- If the voltage of each cell is lower than 1.57 V, then continue the charge during 15 minutes maximum (0.25 hours) or stop if the voltage reaches 1.57 V before 15 minutes. Then continue with the final charge (step 2).
- If the voltage of each cell is higher than 1.57 V then continue with the final charge (step 2).

## 3-2. Rapid partial charge

**NOTE: Do not use this procedure for charging the battery during normal maintenance.**

One of the following two procedures can be used in an emergency situation to charge the battery to approximately 80% of its capacity.

- Charge the battery at 0.5C<sub>1</sub>A until the battery reaches an average of 1.55 V/cell. Do not charge for more than 2 hours and 30 minutes

or

- Charge the battery at 1C<sub>1</sub>A until the battery reaches an average voltage of 1.57 V/cell. Do not charge for more than 1 hour and 15 minutes.

## 3-3. Constant potential charge

**CAUTION: DO NOT CHARGE AT CONSTANT POTENTIAL IF THE OPEN-CIRCUIT BATTERY VOLTAGE IS LESS THAN 1.0 V PER CELL.**

**NOTE: Do not use this procedure for charging the battery during normal maintenance.**

In case of emergency, it is possible to recharge a partially discharged battery by using a constant potential charging system such as exists on the aircraft. With the use of a constant potential system, it is imperative to check the accuracy of the charge rate periodically, and to set the charger voltage according to the average ambient operating temperature.

**NOTE: Do a battery maintenance check as soon as possible to verify battery performance.**

Connect the battery to a constant voltage supply. Charge for a minimum of 1 hour at 1.425 V/cell to get approximately 90% of the rated capacity of the battery.

### 3-4. Other methods of charging

**NOTE: Do not use this procedure for charging the battery during normal maintenance**

In addition to the constant current method of charging, other methods that fully charge the battery can be used, for example, the pulse charging. However, in any case, individual cell voltage checks (**1.5 V/cell for VO/VP/VHP/VXP or 1.55 V/cell for CVH/CVD/CVK**) and electrolyte adjustments must be carried out using a final overcharge sequence at constant current  $0.1C_1A$  for 4 hours. If specific instructions are not given in the charger operating manual, you must first contact Saft.

### 3-5. Active stand-by mode (use of a trickle charge)

**WARNING: This may create conditions for a thermal runaway with all its consequences (unscheduled removal with the possibility of the total loss of the battery and a delayed or canceled flight).**

**CAUTION: WATER CONSUMPTION.**

The battery is continuously charged to an overcharge condition. Saft does not recommend this method, however some operators take responsibility for its use.

This method is not reliable due to quantity and inaccuracy of water consumption.

Example: if a 40 Ah battery remains on a continuous trickle charge of 3 mA/Ah for one month, the total consumption of water is  $35 \text{ cm}^3$  ( $2.1 \text{ in}^3$ ) per cell.

The operator must adjust the electrolyte level before placing the battery on board the aircraft. Otherwise the risk of a battery incident exists (cells dry out before the normal end of the interval maintenance).

PAGE INTENTIONALLY LEFT BLANK

**TESTING AND FAULT ISOLATION**

**1. Introduction**

This chapter is a maintenance guide for the technician.

It shows, for the main causes of failure, either removed for unscheduled maintenance or during scheduled maintenance, the procedures to apply by referring to the corresponding chapter of the OMM. In no case can this diagnostic help replace the technician's expertise or a training on the functioning of the batteries.

**2. Battery electrical faults**

Problem	Probable cause	Correction
(1) Zero battery open-circuit voltage	(a) Defective electrical connector (no contact made)  (b) Link broken	- Check electrical contacts, links and tightness of nuts (refer to <a href="#">INSPECTION/CHECK</a> )
(2) Zero volt with the battery set to "discharge"	(a) Battery fully discharged  (b) Battery circuit open or contacts defective  (c) Cell completely dry	- Do an insulation check (refer to <a href="#">INSPECTION/CHECK</a> )  - Examine the contacts and links - Make sure the terminal nuts are tight (refer to <a href="#">INSPECTION/CHECK</a> ) - Refer to related subsequent steps  - Replace the cell
(3) Low insulation	(a) Leakage of electrolyte	- Disassemble and clean the battery (refer to <a href="#">DISASSEMBLY</a> and <a href="#">CLEANING</a> ) - Do an electrolyte level check (refer to <a href="#">INSPECTION/CHECK</a> )

**Table 1001 - Battery electrical faults**

### 3. Cell faults

Problem	Probable cause	Correction
(1) Too much water decrease for all battery cells	(a) Charge much more than the limit or too much charge at high temperature  (b) Previous maintenance has not been done	- Examine the cause of excessive charge. - If necessary, adjust to normal operating temperature (refer to <a href="#">DESCRIPTION AND OPERATION</a> )
(2) High water dispersion: water consumption in one or more cell(s) is very different from the other cells in the battery	(a) more than 30% above the average value of added water in all cells: leaking cell(s)  (b) less than 30% below the average value of added water in all cells: cell(s) with damaged separator(s)	- Disassemble the battery (refer to <a href="#">DISASSEMBLY</a> ). Clean the battery (refer to <a href="#">CLEANING</a> ). Replace the cell(s). <a href="#">Charge</a> and do an electrolyte level check (refer to <a href="#">INSPECTION/CHECK</a> )  - Do the <a href="#">Supplementary test</a> (refer to <a href="#">INSPECTION/CHECK</a> ). If necessary, replace the cell(s)  - Note the cell location and check the level of water consumption versus other cells at the next maintenance
(3) A cell has higher voltage at the start of charge than is defined in paragraph <a href="#">Charge</a> in chapter <a href="#">DESCRIPTION AND OPERATION</a>	(a) Dry cell	- When the defect occurs, add 5 cm <sup>3</sup> (0.3 in <sup>3</sup> ) of distilled water to the cell. Do not adjust more accurately until the end of the charge
<b>NOTE: If a cell is charged with an insufficient quantity of electrolyte, the temperature may increase too much</b>		
(4) A cell has a lower voltage at the end of charge than is defined in paragraph <a href="#">Charge</a> in chapter <a href="#">DESCRIPTION AND OPERATION</a>	(a) The cell operated at temperatures and charge rates outside the limits, and the separator is damaged  (b) Usual wear after long operation	- Replace the cell (refer to <a href="#">DISASSEMBLY, ASSEMBLY AND STORAGE (INCLUDING TRANSPORTATION)</a> )
(5) Low capacity cell	(a) Insufficient balancing  (b) Usual wear after long operation  (c) Unusual operation, operation at high temperature or operation with low electrolyte	- Repeat <a href="#">Charge</a> and discharge at 1 C <sub>1</sub> A up to three times  - Replace the cell (refer to <a href="#">DISASSEMBLY, ASSEMBLY AND STORAGE (INCLUDING TRANSPORTATION)</a> )  - Do the applicable procedure (refer to <a href="#">INSPECTION/CHECK</a> )
(6) Cell with a swollen case	(a) Cell operated with low electrolyte level; deterioration of separators and damaged plates	- Replace the cell (refer to <a href="#">DISASSEMBLY</a> )
(7) Cell with zero voltage when the battery circuit is open	(a) Short-circuited cell	- Replace the cell (refer to <a href="#">DISASSEMBLY</a> )

Table 1002 - Cell faults

## 4. Physical faults

Problem	Probable cause	Correction
(1) Leakage of electrolyte	<p>(a) Incorrect adjustment of electrolyte level</p> <p>(b) Cell polarity incorrect during high-rate discharge (for example, during the engine start)</p> <p>(c) Too much charge at high temperature or too much current</p> <p>(d) The lower nut is not correctly tightened</p>	<p>- Disassemble and clean the battery (refer to <a href="#">DISASSEMBLY</a> and <a href="#">CLEANING</a>)</p> <p>- Do an electrolyte level check (refer to <a href="#">INSPECTION/CHECK</a>)</p> <p>- Investigate the cause of excessive charge. If necessary, adjust to normal operating temperature (refer to <a href="#">DESCRIPTION AND OPERATION</a>)</p> <p>- Disassemble and clean the battery (refer to <a href="#">DISASSEMBLY</a> and <a href="#">CLEANING</a>)</p> <p>- Do an electrolyte level check (refer to <a href="#">INSPECTION/CHECK</a>)</p> <p>- Torque the lower nut (refer to <a href="#">ASSEMBLY</a> chapter)</p>
(2) Electrolyte found in the battery box	<p>(a) Damaged cell case</p> <p>(b) Leakage of electrolyte</p>	<p>- Replace the cell if necessary and refer to related subsequent steps</p> <p>- Disassemble and clean the battery (refer to <a href="#">INSPECTION/CHECK</a> and <a href="#">CLEANING</a>)</p> <p>- Do an electrolyte level check (refer to <a href="#">INSPECTION/CHECK</a>)</p>
(3) Corrosion on the links	<p>(a) Operation in acidic air</p> <p>(b) Mechanical damage to nickel plating</p>	<p>- Make sure the battery test bench and the storage areas have no materials which can give off acid fumes.</p> <p>- Replace the damaged links (refer to <a href="#">DISASSEMBLY</a>, <a href="#">ASSEMBLY</a>)</p>
(4) The links are too hot	(a) Loose terminals nuts	- Make sure the nuts are torqued (refer to <a href="#">INSPECTION/CHECK</a> )
(5) Battery box & cover damages - Scratches  - Dents, deformations which affect fit or impede the electrical performances of the battery or any of its components - Visible cracks to box or cover	<p>(a) Various, transport</p> <p>(b) Mechanical stress, drop, transport</p> <p>(c) Mechanical stress, drop, transport</p>	<p>- Clean, make sure labels are readable, if not readable replace label(s)</p> <p>- Replace battery box, cover, and affected component(s) refer to <a href="#">DISASSEMBLY</a>, <a href="#">ASSEMBLY</a>)</p> <p>- Replace battery box and / or cover</p>
(6) During flight, the battery produces high pitch sounds (whistle like)	<p>(a) Damaged one-way valve; cut, deformation, or tape at the vent tip is deteriorated or gone</p> <p>(b) Debris or foreign object in one-way valve</p> <p>(c) One-way valve not installed properly</p> <p>(d) One-way valve in contact with other components</p> <p><b>NOTE: One-way valves are not present on all battery types</b></p>	<p>- Replace the damaged one-way valve (refer to <a href="#">DISASSEMBLY</a>)</p> <p>- Disassemble and clean the one-way valve (refer to <a href="#">DISASSEMBLY</a> and <a href="#">CLEANING</a>)</p> <p>- Make sure the one-way-valve is seated properly (refer to figure <a href="#">7001 - One-way valve installation</a>)</p> <p>- Make sure the one-way-valve is not in contact with other components such as wire harness</p>

Table 1003 - Physical faults

PAGE INTENTIONALLY LEFT BLANK



## DISASSEMBLY

### 1. Introduction

#### 1-1. General

**CAUTION: BATTERY DISASSEMBLY SHOULD ONLY BE PERFORMED ON A FULLY DISCHARGED BATTERY. REFER TO CHAPTER [Residual discharge](#) AND [Cell shorting](#).**

**NOTE: Refer to [TESTING AND FAULT ISOLATION](#) to identify possible causes of problems. This chapter gives the necessary level of disassembly to identify and correct possible issues.**

The instructions found in this page block are designed to allow the maintenance person to completely disassemble the battery for the purpose of [General overhaul](#). However, some maintenance operations do not require complete disassembly.

The figure and item numbers are those of the [ILLUSTRATED PARTS LIST](#).

#### 1-2. Safety

Refer to chapter [Safety](#) for caution, risks, and proper personal protective equipments (PPE).

#### 1-3. Job set-up Information

##### 1-3-1. Standard tools

Refer to chapter [Standard tools](#) in [SPECIAL TOOLS, FIXTURES, EQUIPMENT AND CONSUMABLES](#).

##### 1-3-2. Special tools

When special tools are used in this chapter, they are identified by a code number listed in [SPECIAL TOOLS, FIXTURES, EQUIPMENT AND CONSUMABLES](#) chapter.

### 2. Disassembly of the battery

**NOTE: All (###) part identification numbers herein are IPL figure [10001 - Ni-Cd aircraft battery](#) item numbers and are using hypertext facility.**

#### 2-1. Removal of the cover complete

**CAUTION: AVOID CONTACT BETWEEN THE COVER AND THE CELL TERMINALS OR LINKS.**

- Undo the retaining latches.
- Remove the cover complete ([010](#)).

#### 2-2. Removal of the cell assemblies

**CAUTION: (IF APPLICABLE) DO NOT PINCH CABLE HARNESS AGAINST SHARP EDGES.**

**CAUTION: (IF APPLICABLE) DO NOT BEND HEATER TABS EXCESSIVELY.**

**NOTE: Make note of the proper placement of the links ([030](#) to [095](#)) prior to removal.**

**NOTE: Note the cell placement before removal to ensure correct placement during reassembly.**

**NOTE: To facilitate ease of removal, remove the center cell in each row first.**

- Remove cable ties ([-250](#)) (if present).
- Remove the nuts ([110](#)) and the washers ([120](#)) that attach links ([030](#) to [095](#)) to the cell assemblies ([100](#)).
- Remove all links ([030](#) to [095](#)).
- Fully screw the cell extractor tool ([T04](#)) onto a cell terminal then pull up to remove the cell assemblies ([100](#)).

#### 2-3. Removal of the liner-spacer kit

- Remove the liner-spacer kit ([200](#)) taking note the location, position, and count.

#### 2-4. Removal of the one-way valve (if applicable)

- Remove the one-way valve ([-270](#)) by gently pulling on the valve to remove it from the box.

#### 2-5. Removal of the power connector complete

- Remove the power connector cover ([235](#)) (if present).
- Remove the screws ([210](#)) with the washers ([220](#)).
- Remove the power connector complete ([230](#)) and the gasket ([-240](#)).
- Remove the terminal links from the power connector assembly (if applicable).

**2-6. Removal of the sensor connector complete (if applicable)**

**CAUTION: CARE MUST BE TAKEN NOT TO PULL ON WIRES, TWIST OR BEND THE HEATER TABS BACK AND FORTH.**

- Remove the sensor connector cover ([265](#)) -if present-
- Remove the screws (or nut) and the washers (as applicable).
- Remove the sensor connector complete ([260](#)).

## CLEANING

### 1. Introduction

The instructions in this chapter are for the general cleaning of your Saft aircraft battery. The instructions under [Light cleaning](#) are to be done each time the battery is removed from the aircraft, and can be accomplished with no disassembly of the battery. The section [Thorough cleaning](#) includes the instructions for the cleaning of a disassembled battery for the purpose of [General overhaul](#).

### 2. Safety

Refer to chapter [Safety](#) in [INTRODUCTION](#).

### 3. Equipment

#### 3-1. Standard tools

Refer to chapter [Standard tools](#) in [SPECIAL TOOLS, FIXTURES, EQUIPMENT AND CONSUMABLES](#).

#### 3-2. Special tools

When special tools are used in this chapter, they are identified by a code number listed in [SPECIAL TOOLS, FIXTURES, EQUIPMENT AND CONSUMABLES](#) chapter.

#### 3-3. Consumables

When consumables are used in this chapter, they are identified by a code number listed in [SPECIAL TOOLS, FIXTURES, EQUIPMENT AND CONSUMABLES](#) chapter.

### 4. Light cleaning

On an assembled battery.

**CAUTION: DO NOT USE SOLVENT, PETROLEUM SPIRITS, OR OTHER PRODUCTS CONTAINING CHLORIDE FOR CLEANING THE BATTERY. THE USE OF SOLVENTS CAN DEGRADE METAL AND PLASTIC PARTS.**

**NOTE: All (###) part identification numbers herein are IPL figure [10001 - Ni-Cd aircraft battery](#) item numbers and are using hypertext facility.**

#### 4-1. Procedure

**CAUTION: TO PREVENT INJURY WHEN USING COMPRESSED AIR, DIRECT AIR STREAM AWAY FROM THE BODY. USE SAFETY GOGGLES TO PREVENT EYE INJURY FROM AIRBORNE PARTICLES.**

- Remove the battery cover complete ([010](#)).
- Check the battery vent tubes to make sure that they are clean and clear.
- Tighten the vent-valve assemblies ([160](#)) with the universal vent-valve wrench ([T01](#)).
- Remove potassium carbonates (white deposits) from the top of all cell assemblies ([100](#)) using a stiff bristle, non-metallic brush.
- Disperse residual salts and dust particles from the battery using blasts of clean, dry compressed air.

#### 4-2. Lubrication

- Coat all upper nuts ([110](#)) and links ([030](#) to [095](#)) with [M02](#) (use a non-metallic brush).

### 5. Thorough cleaning

#### 5-1. Procedure

Fully disassemble the battery (refer to [DISASSEMBLY](#) chapter).

##### 5-1-1. Cell assemblies

**CAUTION: DO NOT SOAK THE CELLS IN WATER**

Make sure that the vent-valve assembly ([160](#)) is tight using the universal vent-valve wrench ([T01](#)) according to [FITS AND CLEARANCES](#).

Clean the cell assembly ([100](#)) with warm water and a soft brush to easily remove all the electrolyte and mineral salts from the terminals, the cover, and the sides of the cell cases.

Wipe the cell with a cloth and let dry.

##### 5-1-2. Cover complete

Clean the box assembly ([010](#)) with soapy water [M03](#), wipe with a cloth and let dry.

##### 5-1-3. Box assembly

Clean the box assembly ([020](#)) with soapy water [M03](#), wipe with a cloth and let dry.

## CLEANING

**5-1-4. Nuts, screws, washers, and links**

Clean the nuts ([110](#) and [115](#)), screws ([210](#)), washers ([120](#), [150](#), [220](#)), and links ([030](#) to [095](#)) in lightly soapy water [M03](#) with a brush.

Rinse well with clean water and let dry.

**5-1-5. Liner-spacer kit**

Clean the liner-spacer kit ([200](#)) in warm water and let dry.

**5-1-6. Sensor connector complete (if applicable)**

**CAUTION: DO NOT SUBMERGE THE SENSOR CONNECTOR**

Wipe the sensor connector complete ([260](#)) clean using a dry cloth.

**5-1-7. Power connector complete**

**CAUTION: DO NOT SUBMERGE THE POWER CONNECTOR**

Wipe the power connector complete ([230](#)) clean using a damp cloth and let dry.

**5-1-8. Vent-valves**

**CAUTION: THE CLEANING OF THE VENT-VALVE MUST BE DONE WHEN THE CELLS ARE INSTALLED IN THE BOX.**

**CAUTION: VENT-VALVES SHALL REMAIN INSTALLED ON THE CELLS WHEN EVER THE CELLS ARE NOT INSTALLED IN THE BATTERY BOX.**

**5-1-8-1. Removal of the vent-valve assembly**

Remove the vent-valve assembly ([160](#)) with the universal vent-valve wrench [T01](#).

Cover cell vent-valve hole using a lint free cloth to prevent unwanted debris from entering the cell.

Soak vent-valves in distilled water [M01](#) for 30 min to 4 hours to remove electrolyte salts from vent holes.

**5-1-8-2. Installation of the vent-valve assembly**

Make sure the vent-valve assembly ([160](#)) is in good condition. Replace vent-valve assembly ([160](#)) if it is worn.

Install the vent-valve assembly ([160](#)) with the universal vent-valve wrench [T01](#) according to [FITS AND CLEARANCES](#).

**5-1-9. One-way valve (if applicable)**

**CAUTION: IF THE ONE-WAY VALVE IS LOOSE, CRACKED, SHOWS SIGNS OF DAMAGES, OR IF THE TAPE IS MISSING (FROM THE TOP OF THE VALVE), DISCARD THE VALVE AND REPLACE WITH NEW ONE.**

Clean the one-way valve ([-270](#)) in distilled water [M01](#), rub dry with a lint free cloth and let dry.

**NOTE: The one-way valve ([-270](#)) must not be soaked in the same solution as the vent-valve assemblies ([160](#)).**

**5-2. Lubrication**

When the battery is clean (and after installation of the vent-valve), coat all upper nuts ([110](#)) and links ([030](#) to [095](#)) with [M02](#) (use a non-metallic brush).

## INSPECTION/CHECK

### 1. Introduction

This chapter includes the checks, maintenance procedures, and functional tests that must be done to use Saft batteries in flight and on the ground.

**NOTE:** All (###) part identification numbers herein are IPL figure [10001 - Ni-Cd aircraft battery](#) item numbers and are using hypertext facility.

### 2. Maintenance intervals

The aircraft manufacturer and / or operator is responsible for defining the usage and function, including maintenance intervals, for aircraft batteries installed in its aircraft. Saft only provides recommendations that require the agreement of the aircraft manufacturer and / or operator.

**NOTE:** Maintenance steps should be completed in a battery shop.

Saft distinguishes between three types of maintenances: periodical check, regular check and general overhaul.

#### 2-1. Periodical check

The periodical check essentially consists of voltage and insulation checks, discharge of residual capacity and charge with electrolyte level adjustment. The main purpose of this periodical check is to add water which is consumed by electrolysis during battery overcharge. It is normally applied between regular checks but can be omitted if the water consumption measured at the regular check is within allowable limits.

#### 2-2. Regular check

The regular check is the same as the periodical check except that the battery is also deep discharged ("balancing"), followed by a capacity check cycle.

#### 2-3. General overhaul

**NOTE:** The general overhaul is the same as the regular check except that the battery is also disassembled and thoroughly cleaned and inspected.

### 3. Recording

It is very important to record the battery check values (capacity, end of charge voltage, water consumption) for each cell as required in the battery logbook (or equivalent) for each maintenance. It is recommended that an operator tracks these maintenance data in order to verify the interval is correct relative to that particular operation. This may also allow the interval to be extended if the data justifies it.

### 4. Safety

Refer to chapter [Safety](#) in [INTRODUCTION](#).

### 5. Equipment

#### 5-1. Standard tools

Refer to chapter [Standard tools](#) in [SPECIAL TOOLS, FIXTURES, EQUIPMENT AND CONSUMABLES](#).

#### 5-2. Special tools

When special tools are used in this chapter, they are identified by a code number listed in [SPECIAL TOOLS, FIXTURES, EQUIPMENT AND CONSUMABLES](#) chapter.

6. Periodical check

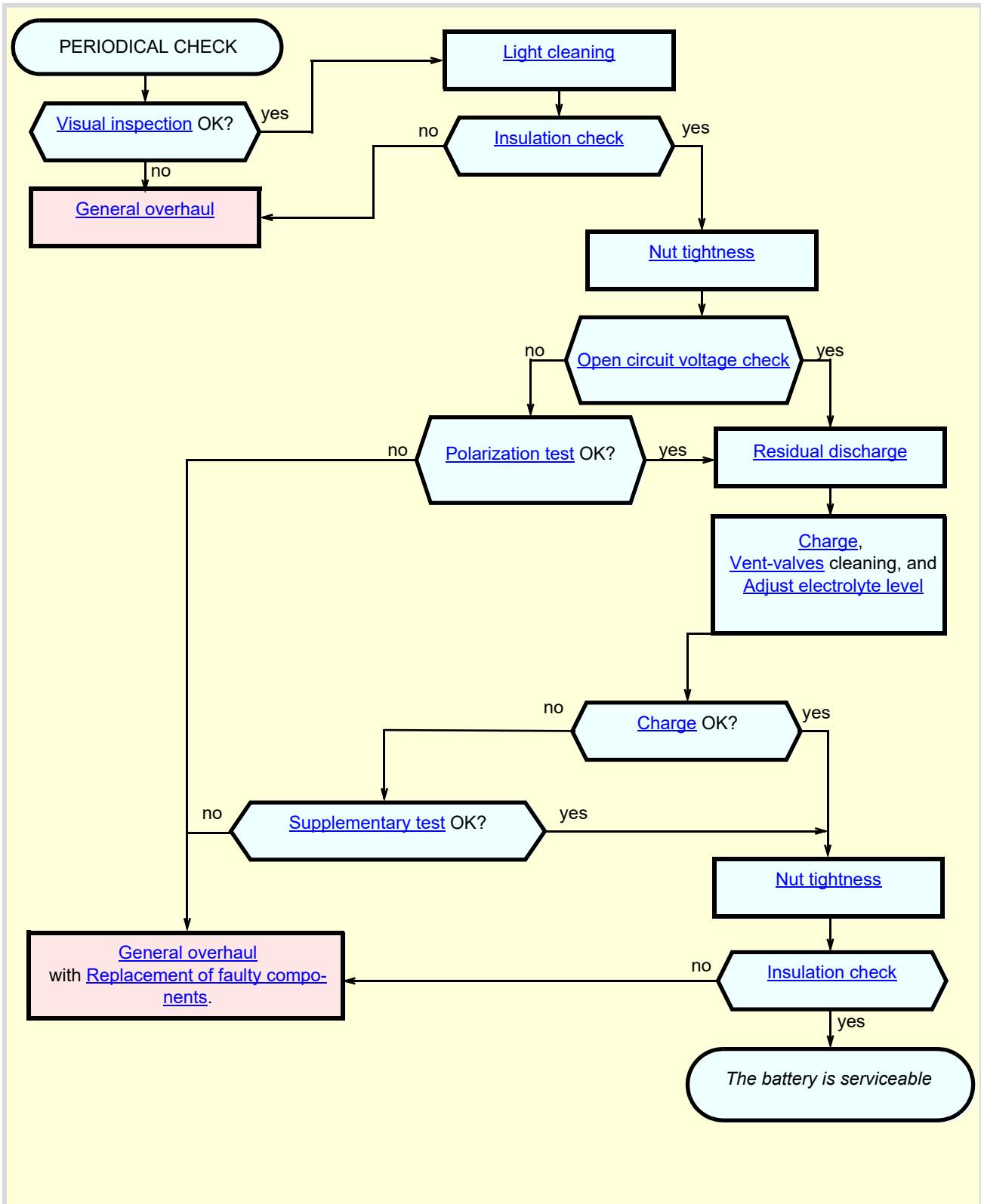

Figure 5001 - Periodical check

**NOTE:** Time periods are given as a guideline. Modify in accordance with operational experience.

**NOTE:** Periodic and regular maintenance checks may be combined if operating hours permit.

At specific intervals according to aircraft use or every 3 months, test the battery according to the above figure. Consult the aircraft manufacturer for specific maintenance intervals or special procedures to be followed.

INSPECTION/CHECK

6-1. Visual inspection

**CAUTION: WORN AIRCRAFT POWER CONNECTORS AND/OR LOOSE CONNECTIONS CAN GREATLY AFFECT THE PERFORMANCE OF THE BATTERY. A DEFECTIVE POWER CONNECTOR CAN CAUSE OVERHEATING, BATTERY SELF-DISCHARGE AND LOW VOLTAGE IN SERVICE.**

Visual inspection should be done each time the battery is removed from the equipment for maintenance.

- Remove the cover complete (010)
- Visually check each cell assembly (100) for evidence of electrolyte leakage. If OK proceed to [Light cleaning](#). If salt or traces of electrolyte are detected, identify as NOT OK, proceed to [General overhaul](#). Excessive salt around terminal posts indicates possible leakage from the terminal O-ring. During [General overhaul](#), verify torque of the lower nut (115) (refer to chapter [ASSEMBLY](#)).
- Inspect the links (030 to 095), upper nuts (110), and washers (120 to 150). The hardware should be free of bends, tarnish, corrosion, burns, or any loss of nickel plating. Minor tarnish can be polished off with a fine wire brush. If OK, proceed to [Light cleaning](#). If NOT OK, proceed to [General overhaul](#) and replace defective hardware.
- Check the power connector complete (230) for evidence of arcing, corrosion, cracks, or cross-threaded terminals. If OK, proceed to [Light cleaning](#). If NOT OK, proceed to [General overhaul](#) and replace the defective power connector.
- (IF APPLICABLE) Inspect the sensor connector complete (260) for bent or loose pins, corrosion, cracks, faulty wire connections, evidence of arcing, or cracked or loose potting material. If OK, proceed to [Light cleaning](#). If NOT OK, proceed to [General overhaul](#) and replace the defective sensor connector.
- (IF APPLICABLE) Inspect the temperature sensor and blanket harness assembly for obvious damage. This in no way replaces the full testing procedures found hereafter which ensures full operation of the sensor assembly. If OK, proceed to [Light cleaning](#). If NOT OK proceed to [General overhaul](#) and replace the defective sensor connector complete (260).
- (IF APPLICABLE) Inspect the thermostat assemblies for any damaged or loose wire connections, cracks, dents, or other physical damage. If OK proceed to [Light cleaning](#). If NOT OK, proceed to [General overhaul](#) and replace the defective sensor connector complete (260).
- (IF APPLICABLE) Visually check all wiring insulation to ensure there is no evidence of cracks, cuts, or bubbling. If OK, proceed to [Light cleaning](#). If NOT OK, proceed to [General overhaul](#) and replace the defective sensor connector. Any evidence of damage to the temperature sensor and/or heater blanket harness assembly requires the sensor connector complete (260) replacement.
- Inspect the battery box assembly (020) and cover complete (010) for any damage. Make sure the cover gasket (011) is undamaged and fully secured to the cover complete (010). If OK, proceed to [Light cleaning](#). If NOT OK, proceed to [General overhaul](#) and replace the damaged box assembly (020) or cover complete (010).

6-2. Insulation check

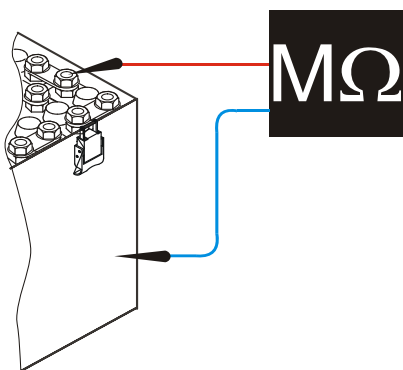

**NOTE: A breakdown in electrical insulation between the cell assemblies (100) and the battery box assembly (020) will result in a “leakage” current, which over time will discharge the battery.**

- Set the megohmmeter to 250 V DC.
- Measure the insulation between the positive terminal of each cells and the battery box assembly (020).
- Measure the insulation between the connector positive pin and the battery box assembly (020).
- Measure the insulation between each pin of the sensor connector and the battery box assembly (020).

Refer to the table below for the acceptance criteria.

250 KΩ	2 MΩ	10 MΩ
250 KΩ	2 MΩ	10 MΩ
Do a <a href="#">General overhaul</a> . Check the cause per <a href="#">TESTING AND FAULT ISOLATION</a>	Acceptable but <a href="#">Thorough cleaning</a> is recommended	Acceptable for in service battery For a new battery (direct from factory with no charge made by the customer) a <a href="#">Thorough cleaning</a> is recommended
		Mandatory level of insulation for new or in service battery after <a href="#">Thorough cleaning</a>

## INSPECTION/CHECK

**6-3. Nut tightness**

Tighten and check the torque of all cell terminal upper nuts ([110](#)) and connector terminal nuts ([110](#)) (refer to [FITS AND CLEARANCES](#)).

**6-4. Open circuit voltage check**

Measure the open circuit voltage of each cell assembly ([100](#)). If all the cells are > 1.05 V, continue with [Residual discharge](#). Otherwise, do a [Polarization test](#).

**6-5. Polarization test**

Charge the battery at 0.1C<sub>1</sub>A for 1 hour and 30 min.

Leave the battery on open circuit for 1 hour.

Measure the open circuit voltage of each cell. If any cell is zero volt or negative polarity, do a [General overhaul](#) with [Replacement of faulty components](#). If all cells are above zero volt, continue with [Residual discharge](#).

**6-6. Residual discharge**

Discharge the battery at the 1C<sub>1</sub>A or 0.5C<sub>1</sub>A rate until each cell in the battery is discharged to 1.0 V or below.

**6-7. Adjust electrolyte level**

**WARNING:** Take care not to tilt cells while vent-valves are loosened or removed. Contact of electrolyte with skin can cause burns (refer to chapter [Safety](#)). If contact occurs, flush area with large amounts of water for 15 to 30 minutes. Electrolyte in the eyes is very serious. Flush with water and contact a doctor immediately.

**CAUTION:** USING ANYTHING OTHER THAN DISTILLED OR DEIONIZED WATER [M01](#) IN NI-CD CELLS WILL CAUSE ELECTROLYTE CONTAMINATION AND IRREVERSIBLE DAMAGE TO THE CELLS.

**CAUTION:** THE BATTERY MUST BE FULLY CHARGED BEFORE ADJUSTING THE ELECTROLYTE LEVEL. USE ONLY DISTILLED OR DEIONIZED WATER [M01](#) (REFER TO CHAPTER [SPECIAL TOOLS, FIXTURES, EQUIPMENT AND CONSUMABLES](#)).

**DO NOT RE-USE WATER REMOVED FROM CELLS.**

**THE VOLUME REQUIRED TO LEVEL THE FIRST CELL WILL SERVE AS A GUIDE FOR REQUIREMENTS OF THE REMAINING CELLS BUT THE AMOUNT OF WATER REQUIRED FOR EACH CELL CAN VARY, SO CARRY OUT THIS CHECK ON A CELL BY CELL BASIS. EACH CELL MUST BE LEVELED INDIVIDUALLY. IF THE QUANTITY OF WATER ADDED PER CELL IS ABOVE 80 % OF THE ELECTROLYTE WATER VOLUME SHOWN IN THE SPECIFICATION TABLES (REFER TO SECTION [Battery specifications](#)), CHECK THE CHARGING SYSTEM. IF IT IS FUNCTIONING PROPERLY, SHORTEN THE TIME PERIOD BETWEEN SERVICING.**

Always take appropriate precautions to prevent any foreign substances from entering the cell. Anything other than distilled or deionized water [M01](#) that enters the cells will cause electrolyte contamination and will affect overall performance.

The amount of time that the vent-valve assemblies ([160](#)) are removed from the cell assembly ([100](#)) for maintenance should be limited to prevent as much air as possible from entering the cell. Carbon dioxide in the air will combine with the electrolyte to form potassium carbonate. Potassium carbonate will increase the internal resistance of the cells and thus decrease the performance at low temperatures and during high rate discharges. Always make sure that the vent-valve assemblies ([160](#)) are properly secured while the battery is in use.

Electrolyte level adjustment must be done during the last 15-30 minutes of the 4 hours overcharge at 0.1C<sub>1</sub> A rate of charge or last 15-30 minutes of the 5 hours at 0.1C<sub>1</sub> A for the supplementary test.



## INSPECTION/CHECK

Adjust the level of electrolyte, one cell at a time, using the following instructions:

- 1. Remove the vent-valve assembly (160) (with the O-ring) with the universal vent-valve wrench (T01).
- 2. Check the nozzle length before fitting it to the syringe (refer to paragraph [Special tools](#) for proper nozzle).
- 3. Insert the syringe (T02) into the cell assembly (100) opening until the shoulder of the nozzle rests on the vent-valve seat per figure [5002 - Position of syringe in cell vent seat](#).

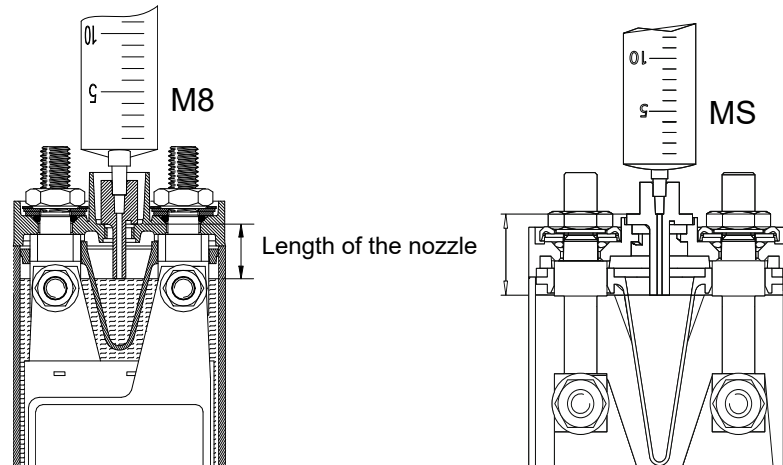

Figure 5002 - Position of syringe in cell vent seat

- 4. Withdraw the plunger and check for any liquid in the syringe. Any excess liquid in the cell will be drawn into the syringe until the electrolyte is level with the end of the nozzle. This is the correct level for the electrolyte.  
If the liquid level is too low, the syringe will remain empty, indicating that the end of the syringe nozzle did not reach the liquid in the cell. In this case, replenish low electrolyte using distilled water [M01](#).  
If the liquid level is too low, the syringe will remain empty, indicating that the end of the syringe nozzle did not reach the liquid in the cell. In this case, replenish low electrolyte.
- 5. Draw 5 cm<sup>3</sup> (0.3 in<sup>3</sup>) of the distilled water [M01](#) into the syringe and inject it into the cell and,
- 6. With the syringe nozzle remaining on the vent-valve assembly (160) seat, slowly withdraw the plunger in the syringe one time again.
- 7. If the syringe remains empty, repeat steps 5 and 6, counting the total volume required to achieve the correct level. Record the amount of water added to each cell on the maintenance record.
- 8. At the point in step 6 when some excess liquid is drawn into the syringe, the correct level for that cell has been reached. Expel the excess liquid into a separate container for disposal. **Do not re-use the liquid removed from cells.** Check with local authorities for proper disposal of hazardous waste.

### 6-8. Supplementary test

This test is used to confirm cell(s) faults:

- Do a charge of the battery with the main and the final charge (refer to [Charge](#)).
- Continue to charge for 5 hours at 0.1C<sub>1</sub>A.
- The individual cell voltage must be greater than:
  - $U \geq 1.5 \text{ V}$  for VO/VP/VHP/VXP
  - $U \geq 1.55 \text{ V}$  for CVH/CVD/CVK
- Adjust the electrolyte level (refer to [Adjust electrolyte level](#)).
- If the cell voltage is still not met within the 5 hours, replace the defective cell assemblies (100). Follow [General overhaul](#).
- If the cell(s) voltage(s) decreases by at least 0.03 V between the beginning and the end of the supplementary test, then replace the defective cell assemblies (100). Follow [General overhaul](#).

**NOTE: Cell voltage should be checked every 30 min. If the voltage criteria is reached before 5 hours, you can stop the supplementary test.**

7. Regular check

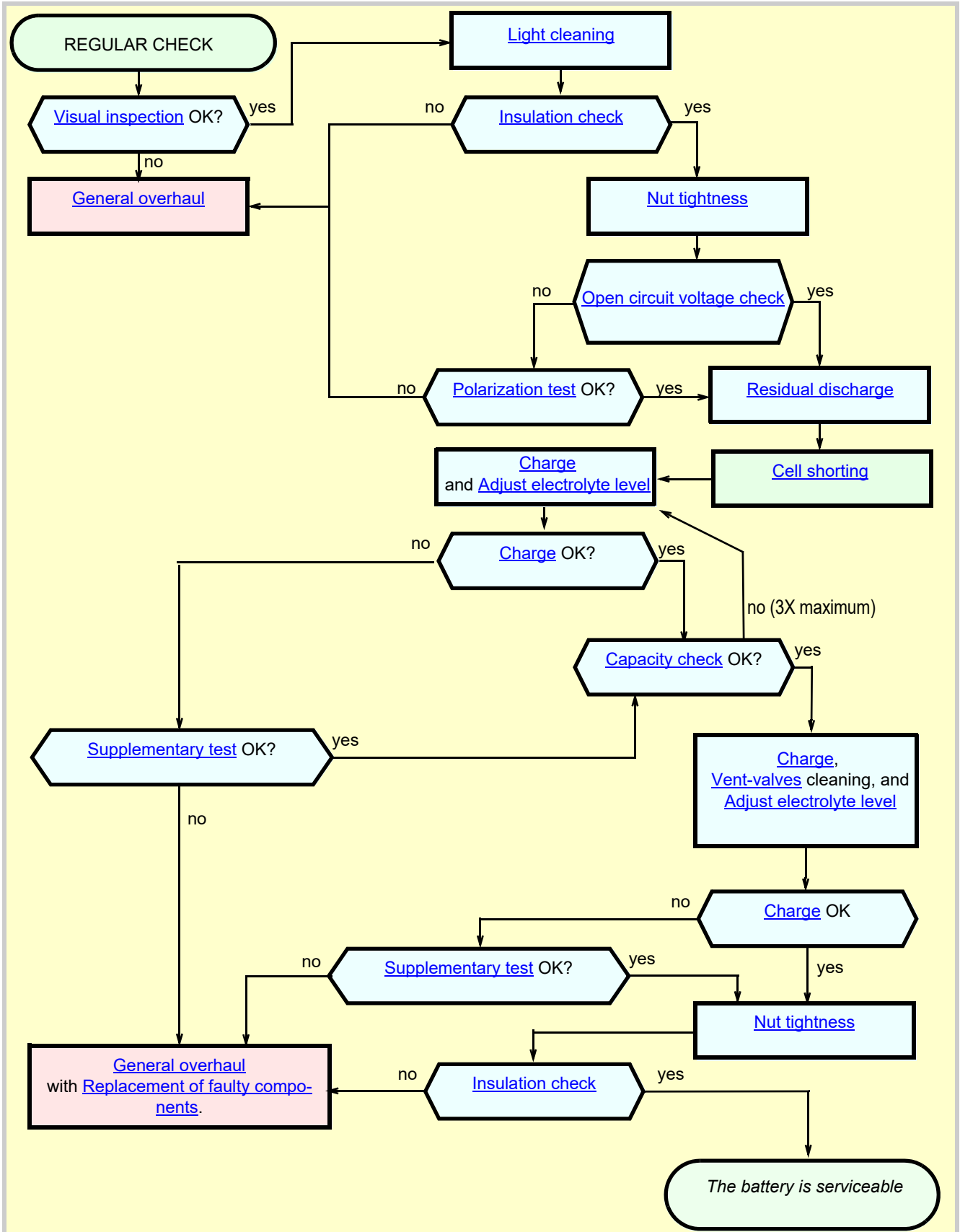

Figure 5003 - Regular check

NOTE: Time periods are given as a guideline. Modify in accordance with operational experience.

NOTE: Periodic and regular maintenance checks may be combined if operating hours permits.

At specific intervals according to aircraft use, or after a maximum of one year, test the battery according to the above figure. Consult the aircraft manufacturer for specific maintenance intervals or special procedures to be followed.

## INSPECTION/CHECK

**7-1. Cell shorting**

As each cell's voltage drops below 1.0 V, connect an equalizing resistor ([T03](#)) across each cell's terminals. Leave the resistors in position for 12 to 24 hours to allow each cell to completely discharge and the battery to cool.

**NOTE: As an alternative to the resistor a shorting clip can be applied when the voltage has dropped to 0.5 V per cell.**

**NOTE: It is suggested to use a low charge 0.1 C<sub>1</sub>A rate after cell shorting.**

**7-2. Capacity check**

This procedure is used to calculate the battery capacity. It can be done in 2 different methods.

**NOTE: If the capacity check is NOT OK, do: [Charge](#), [Adjust electrolyte level](#), and [Capacity check](#) loop 3 times maximum. If capacity check is still NOT OK, then follow [General overhaul](#) to replace defective cell assemblies ([100](#)).**

**7-2-1. Method 1**

This method is suitable for devices that can record individual cell voltages and discharge current continuously over time.

- Discharge the battery at 1C<sub>1</sub>A and record the individual voltages of all cells.
- Record the time when each cell falls to 1.0 V. Once the cell voltage falls between 0.5 V and 1.0 V, apply equalizing resistor ([T03](#)) across the low-voltage-cell terminals.
  - If the recorded time is greater than or equal to 51 min for VO and VP or 1 hour for VHP, VXP, CVH, CVD and CVK cells, the capacity test is OK.
  - If the recorded time is less than 51 min for VO and VP or 1 hour for VHP, VXP, CVH, CVD and CVK cells, the capacity test is NOT OK.

**7-2-2. Method 2**

This method is especially suitable for battery shop that manually records the voltage using a multimeter.

- Discharge the battery at 1C<sub>1</sub>A. during 51 min for VO and VP and 1 hour for VHP, VXP, CVH, CVD and CVK cells.
- Record the voltage of each cell at the end of the discharge:
  - If the recorded voltage of each cell is greater than or equal to 1.0 V, the capacity test is OK.
  - If any cell voltage is less than 1.0 V, the capacity test is NOT OK.

8. General overhaul

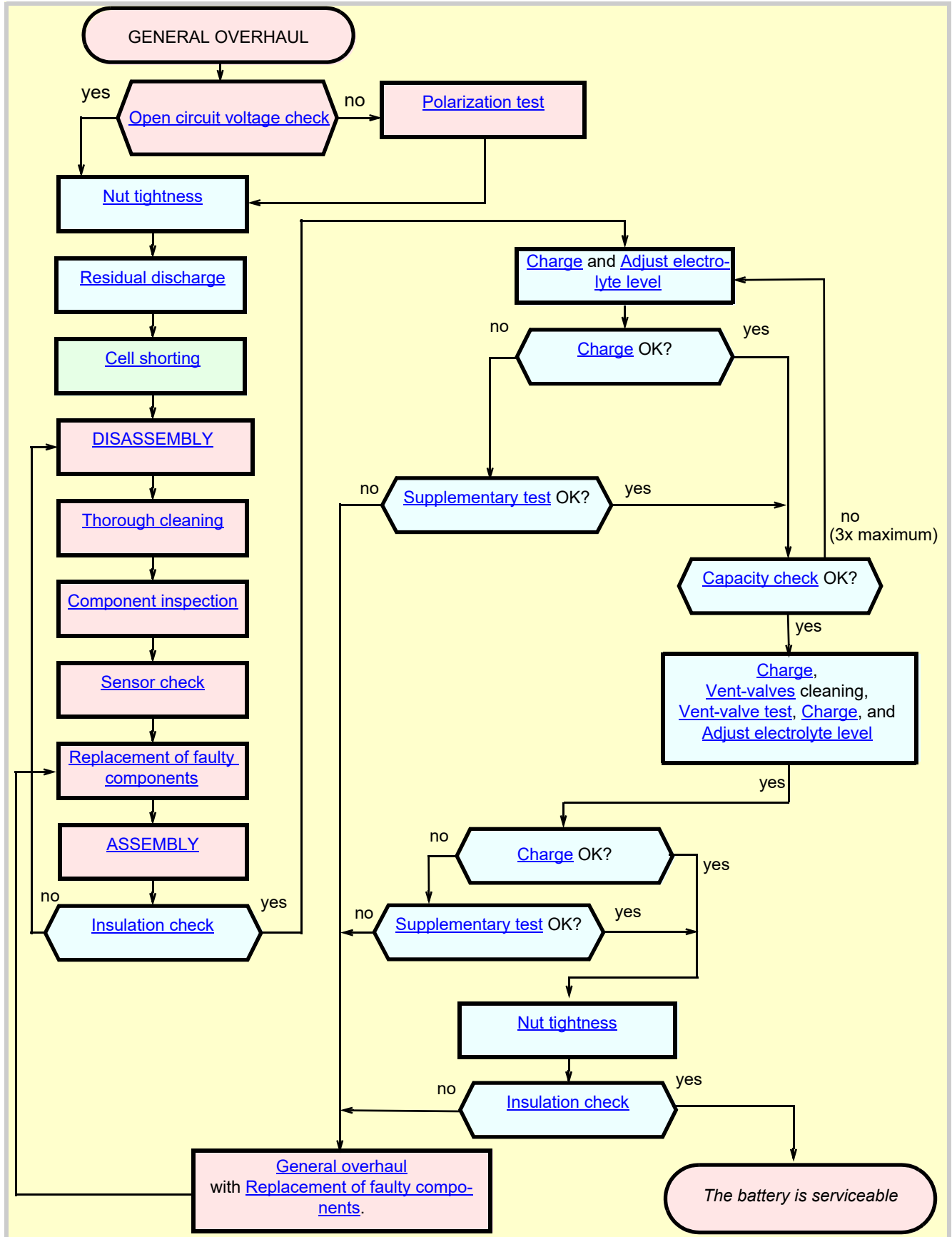

Figure 5004 - General overhaul

**NOTE:** Time periods are given as a guideline. Modify in accordance with operational experience.

At specific intervals according to aircraft use, or after a maximum of one year, test the battery according to the above figure. Consult the aircraft manufacturer for specific maintenance intervals or special procedures to be followed.

## INSPECTION/CHECK

**8-1. Component inspection****8-1-1. Cell assemblies**

Make sure that the lower terminal nuts ([115](#)) are tight (refer to [FITS AND CLEARANCES](#) chapter).

Make sure that cell containers show no leakage.

**8-1-2. Box assembly**

Make sure the sides of the box assembly ([020](#)) are straight and free of dents.

**8-1-3. Nuts, screws, links and washers**

Discard nuts ([110](#) and [115](#)), washers ([120](#) to [150](#), and [220](#)), screws ([210](#)), and links ([030](#) to [095](#)) that show signs of corrosion or damage.

**8-1-4. Power connector complete**

Check the power connector complete ([230](#)) for evidence of arcing, corrosion, cracks, or cross-threaded terminals. Replace the defective power connector complete ([230](#)).

**8-2. Replacement of faulty components****8-2-1. Cells - 3/5 cells rule**

Saft strongly recommends to change all the cells or replace the complete battery if:

- **One or more cells are found to be faulty and 5 of the original cells in the battery had previously been changed during the previous maintenance**

or

- **Three or more cells are found to be faulty during the same maintenance.**

The 3/5 cells rule does not apply to the following failures:

- Mechanical failure such as terminal thread damage.
- Cell leakage.
- Cell short-circuit.

**NOTE: All cells that are changed must be replaced by a new Saft cell assembly.**

**8-2-2. Other components**

Any other components that are to be changed must be replaced by a new Saft component.

**8-3. Sensor check**

**NOTE: Erratic measurements observed constitute a failure of the sensor check.**

**8-3-1. Insulation check**

Make sure that the insulation between each pin of the sensor connector assembly ([260](#)) and all metal parts of the sensor connector is > 10 MΩ at 250 VDC.

**8-3-2. Sensor connector check**

Do this test in a climatic chamber or equivalent device with the sensor disassembled from the battery. Check the sensor, if applicable, according to table [5001 - Sensor connector check](#).

When a sensor includes a thermostat with the sentence “closes on rise” or “opens on rise,” test the thermostat switching temperature while the temperature in the climatic chamber is increasing.

When a sensor includes a thermostat with the sentence “closes on fall,” test the thermostat switching temperature while the temperature in the climatic chamber is decreasing.

## INSPECTION/CHECK

Battery description	Sensor (260) P/N (F6177)	Sensor (260) P/N (09052)	Sensor connector check criteria
151CH2	414425	-	A-B: closes on rise @ +71 °C ± 5 °C (+160 °F ± 9 °F) A-B: 2.2 KΩ @ +25 °C ± 2 °C (+77 °F ± 4 °F) C-D: 276 to 327 KΩ @ +25 °C ± 2 °C (+77 °F ± 4 °F)
	415235	-	A-B: opens on rise @ +8 °C ± 5 °C (+46 °F ± 9 °F) A-B: 138 Ω @ +5 °C (+61 °F) or less
176CH	-	019271-000	A-B: closes on rise @ +63 °C ± 5 °C (+146 °F ± 9 °F) C-D: closes on rise @ +63 °C ± 5 °C (+146 °F ± 9 °F)
176CH6	-	023669-000	A-B: 276 to 327 KΩ @ +25 °C ± 2 °C (+77 °F ± 4 °F) C-D: closes on rise @ +71 °C ± 5 °C (+160 °F ± 9 °F)
178CH1	410218	-	A-B: 276 to 327 KΩ @ +25 °C ± 2 °C (+77 °F ± 4 °F) C-D: closes on rise @ +71 °C ± 5 °C (+160 °F ± 9 °F)
272CH1	412757	023258-000	1-2: closes on rise @ +71 °C ± 5 °C (+160 °F ± 9 °F) 1-3: closes on rise @ +71 °C ± 5 °C (+160 °F ± 9 °F) 2-3: short circuit
276CH7	413032 replaced by 416433	-	A-B: 198 to 202 Ω @ +60 °C ± 1 °C (+141 °F ± 2.8 °F) A-B: 169 to 179 Ω @ +24 °C ± 3 °C (+75 °F ± 5 °F)
276CH10	166900	018802-000	A-B: 49.4 to 50.4 KΩ @ +25 °C ± 2 °C (+77 °F ± 4 °F) B-C: 276 to 327 KΩ @ +25 °C ± 2 °C (+77 °F ± 4 °F)
276CH23	166900	018802-000	A-B: 49.75 KΩ @ +25 °C ± 2 °C (+77 °F ± 4 °F) B-C: 276 to 327 KΩ @ +25 °C ± 2 °C (+77 °F ± 4 °F)
	114722	017125-000	C-D: closes on rise @ +71 °C ± 5 °C (+160 °F ± 9 °F)
277CH1	161297	-	B-E: closes on rise @ +57 °C ± 5 °C (+135 °F ± 9 °F) D-L1: short circuit
310VX-2	411980	-	A-B: 3 KΩ @ +25 °C ± 2 °C (+77 °F ± 4 °F) C: middle point with 4.94 to 5.04 KΩ resistor D-E: closes on rise @ +71 °C ± 5 °C (+160 °F ± 9 °F)
345CD1	411991	-	B-C: closes on rise @ +65 °C ± 5 °C (+149 °F ± 9 °F) B-D: short circuit
405CH3	415512	-	A-B: 2.04 to 2.48 kΩ @ +25 °C ± 2 °C (+77 °F ± 4 °F) C-+: 4.95 to 5.05 kΩ D-middle point: 4.95 to 5.05 kΩ E-F: opens on rise @ +71 °C ± 5 °C (+160 °F ± 9 °F) G--: 4.95 to 5.05 kΩ
407CH-2	-	023697-000	A-B: opens on rise @ +71 °C ± 5 °C (+160 °F ± 9 °F) C-D: close after open +60 °C ± 5 °C (+140 °F ± 9 °F)
407CH5	114722	017125-000	C-D: closes on rise @ +71 °C ± 5 °C (+160 °F ± 9 °F)
407CH9	410929	019756-000	A-C/D-F: 95 to 105 Ω @ +25 °C ± 2 °C (+77 °F ± 4 °F) B-C/E-F: 28 to 32 KΩ @ +25 °C ± 2 °C (+77 °F ± 4 °F)
407CH-11	-	019422-000	4-6: short circuit 8-9: opens on rise @ +67 °C ± 5 °C (+153 °F ± 9 °F) 11-12: 2.04 to 2.48 kΩ @ +25 °C ± 2 °C (+77 °F ± 4 °F)
407CH13	413861	019504-000	A-B: 171 to 177 Ω @ +24 °C ± 3 °C (+75 °F ± 5 °F) A-B: 197 to 203 Ω @ +60 °C ± 3 °C (+140 °F ± 5 °F) C-D: 171 to 177 Ω @ +24 °C ± 3 °C (+75 °F ± 5 °F) A-B: 197 to 203 Ω @ +60 °C ± 3 °C (+140 °F ± 5 °F)
437CH14	413861	019504-000	A-B: 171 to 177 Ω @ +24 °C ± 3 °C (+75 °F ± 5 °F) A-B: 197 to 203 Ω @ +60 °C ± 3 °C (+140 °F ± 5 °F) C-D: 171 to 177 Ω @ +24 °C ± 3 °C (+75 °F ± 5 °F) A-B: 197 to 203 Ω @ +60 °C ± 3 °C (+140 °F ± 5 °F)
438CH2	-	023669-000	
442CH2	114722	017125-000	C-D: closes on rise @ +71 °C ± 5 °C (+160 °F ± 9 °F)

Table 5001 - Sensor connector check

## INSPECTION/CHECK

Battery description	Sensor (260) P/N (F6177)	Sensor (260) P/N (09052)	Sensor connector check criteria
447CH1	414976	-	A-B: closes on rise @ +71 °C ± 5 °C (+160 °F ± 9 °F) A-C: closes on rise @ +71 °C ± 5 °C (+160 °F ± 9 °F)
447CH3	416443	-	A-eyelet: middle point with 4.99 KΩ 1% resistor B-eyelet -: 4.94 to 5.04 KΩ resistor H-eyelet +: 4.94 to 5.04 KΩ resistor C-D: thermistor 89.98 to 90.78 Ω @ 0 °C (+32 °F) E-F: thermistor 89.98 to 90.78 Ω @ 0 °C (+32 °F)
447CH8	410218	-	A-B: 276 to 327 KΩ @ +25 °C ± 2 °C (+77 °F ± 4 °F) C-D: closes on rise @ +71 °C ± 5 °C (+160 °F ± 9 °F)
505CH3	114722	017125-000	C-D: closes on rise @ +71 °C ± 5 °C (+160 °F ± 9 °F)
616	411157	-	A-B: closes on rise @ +57 °C ± 5 °C (+135 °F ± 9 °F) B-C: closes on rise @ +71 °C ± 5 °C (+160 °F ± 9 °F)
1277-1	114722	017125-000	C-D: closes on rise @ +71 °C ± 5 °C (+160 °F ± 9 °F)
1277-2	-	019656-000	
1277-3	414139	-	A-B: 28 to 32 KΩ @ +25 °C ± 2 °C (+77 °F ± 4 °F) C-D: closes on rise @ +71 °C ± 5 °C (+160 °F ± 9 °F)
1608-1	412757	023258-000	1-2: closes on rise @ +71 °C ± 5 °C (+160 °F ± 9 °F) 1-3: closes on rise @ +71 °C ± 5 °C (+160 °F ± 9 °F) 2-3: short circuit
1656-1	114722	017125-000	C-D: closes on rise @ +71 °C ± 5 °C (+160 °F ± 9 °F)
1656-2	162901	-	C-D: closes on rise @ +57 °C ± 5 °C (+135 °F ± 9 °F)
1656-5	117497	019220-000	A-B: closes on rise @ +57 °C ± 5 °C (+135 °F ± 9 °F) C-D: closes on rise @ +71 °C ± 5 °C (+160 °F ± 9 °F)
1658-2	162901	-	C-D: closes on rise @ +57 °C ± 5 °C (+135 °F ± 9 °F)
1666-1	116051	018652-000	A-B: closes on rise @ +71 °C ± 5 °C (+160 °F ± 9 °F) B-C: short circuit
1756	-	019271-000	A-B: closes on rise @ +63 °C ± 5 °C (+146 °F ± 9 °F) C-D: closes on rise @ +63 °C ± 5 °C (+146 °F ± 9 °F)
1756-2	-	023808-500	A-B: closes on rise @ +57 °C ± 5 °C (+135 °F ± 9 °F) C-D: closes on rise @ +71 °C ± 5 °C (+160 °F ± 9 °F)
2353-1	114722	017125-000	C-D: closes on rise @ +71 °C ± 5 °C (+160 °F ± 9 °F)
2371-1	114722	017125-000	C-D: closes on rise @ +71 °C ± 5 °C (+160 °F ± 9 °F)
2371-2	162901	-	C-D: closes on rise @ +57 °C ± 5 °C (+135 °F ± 9 °F)
2371-4	166900	018802-000	A-B: 49.4 to 50.4 KΩ @ +25 °C ± 2 °C (+77 °F ± 4 °F) B-C: 276 to 327 KΩ @ +25 °C ± 2 °C (+77 °F ± 4 °F)
2371-5	162366	019437-000	AF-BC: closes on rise @ +71 °C ± 5 °C (+160 °F ± 9 °F) AF-DE: closes on rise @ +57 °C ± 5 °C (+135 °F ± 9 °F)
2371-6	410156	-	A-B: closes on rise @ +57 °C ± 5 °C (+135 °F ± 9 °F) B-E: closes on rise @ +57 °C ± 5 °C (+135 °F ± 9 °F) C-D: closes on rise @ +65 °C ± 5 °C (+145 °F ± 9 °F) C-E: closes on rise @ +65 °C ± 5 °C (+145 °F ± 9 °F)
2371-7	411345	-	A-C: 108 to 111 Ω @ +23 °C (+73 °F) B-C: 30 KΩ @ +23 °C (+73 °F) D-E: 100 Ω @ +23 °C (+73 °F) E-F: 30 KΩ @ +23 °C (+73 °F)
2376-1	114722	017125-000	C-D: closes on rise @ +71 °C ± 5 °C (+160 °F ± 9 °F)
2376-2	117497	019220-000	A-B: closes on rise @ +57 °C ± 5 °C (+135 °F ± 9 °F) C-D: closes on rise @ +71 °C ± 5 °C (+160 °F ± 9 °F)
2376-3	-	018484-000	1-2: closes on rise @ +57 °C ± 5 °C (+135 °F ± 9 °F) 3-4: closes on rise @ +57 °C ± 5 °C (+135 °F ± 9 °F)

Table 5001 - Sensor connector check (continued)

## INSPECTION/CHECK

Battery description	Sensor (260) P/N (F6177)	Sensor (260) P/N (09052)	Sensor connector check criteria
2376-4	166900	018802-000	A-B: 49.4 to 50.4 K $\Omega$ @ +25 °C $\pm$ 2 °C (+77 °F $\pm$ 4 °F) B-C: 276 to 327 K $\Omega$ @ +25 °C $\pm$ 2 °C (+77 °F $\pm$ 4 °F)
2376-7	413032 replaced by 416433	-	A-B: 200 $\Omega$ $\pm$ 2 $\Omega$ @ +60 °C $\pm$ 1 °C (+141 °F $\pm$ 2.8 °F) A-B: 174 $\Omega$ $\pm$ 5 $\Omega$ @ +24 °C $\pm$ 3 °C (+75 °F $\pm$ 5 °F)
2376-8	413469	-	AB: closes on rise @ +71 °C $\pm$ 5 °C (+160 °F $\pm$ 9 °F)
2376-9	-	018932-000	A-B: 174 $\Omega$ @ +24 °C (+75 °F) A-B: 200 $\Omega$ @ +60 °C (+140 °F) C-D: 174 $\Omega$ @ +24 °C (+75 °F) C-D: 200 $\Omega$ @ +60 °C (+140 °F)
2376-10	-	019498-000	A-B: closes on rise @ +63 °C $\pm$ 5 °C (+146 °F $\pm$ 9 °F)
2386-1	117497	019220-000	A-B: closes on rise @ +57 °C $\pm$ 5 °C (+135 °F $\pm$ 9 °F) C-D: closes on rise @ +71 °C $\pm$ 5 °C (+160 °F $\pm$ 9 °F)
2506-1	116051	018652-000	A-B: closes on rise @ +71 °C $\pm$ 5 °C (+160 °F $\pm$ 9 °F) B-C: short circuit
2506-2	116051	018652-000	A-B: closes on rise @ +71 °C $\pm$ 5 °C (+160 °F $\pm$ 9 °F) B-C: short circuit
2708-1	411758		C-D: closes on rise @ +71 °C $\pm$ 5 °C (+160 °F $\pm$ 9 °F)
2708-2	114722	017125-000	C-D: closes on rise @ +71 °C $\pm$ 5 °C (+160 °F $\pm$ 9 °F)
2778-2	117497	019220-000	A-B: closes on rise @ +57 °C $\pm$ 5 °C (+135 °F $\pm$ 9 °F) C-D: closes on rise @ +71 °C $\pm$ 5 °C (+160 °F $\pm$ 9 °F)
2778-5	166578	-	A-B: 40 K $\Omega$ @ +23 °C (+73 °F) E-F: 40 K $\Omega$ @ +23 °C (+73 °F) D-G: short circuit
2778-10	413032 replaced by 416433	-	A-B: 198 to 202 $\Omega$ @ +60 °C $\pm$ 1 °C (+141 °F $\pm$ 2.8 °F) A-B: 169 to 179 $\Omega$ @ +24 °C $\pm$ 3 °C (+75 °F $\pm$ 5 °F)
2778-15	413330	-	A-B: closes on rise @ +71 °C $\pm$ 5 °C (+160 °F $\pm$ 9 °F) C-D: closes on rise @ +71 °C $\pm$ 5 °C (+160 °F $\pm$ 9 °F) E-F: opens on rise @ +71 °C $\pm$ 5 °C (+160 °F $\pm$ 9 °F)
2778-18	413032 replaced by 416433	-	A-B: 198 to 202 $\Omega$ @ +60 °C $\pm$ 1 °C (+141 °F $\pm$ 2.8 °F) A-B: 169 to 179 $\Omega$ @ +24 °C $\pm$ 3 °C (+75 °F $\pm$ 5 °F)
4000A1-1	116051	018652-000	A-B: closes on rise @ +71 °C $\pm$ 5 °C (+160 °F $\pm$ 9 °F) B-C: short circuit
4006A-1	116051	018652-000	A-B: closes on rise @ +71 °C $\pm$ 5 °C (+160 °F $\pm$ 9 °F) B-C: short circuit
4008-1	116051	018652-000	A-B: closes on rise @ +71 °C $\pm$ 5 °C (+160 °F $\pm$ 9 °F) B-C: short circuit
4015CH-11	-	019422-000	4-6: short circuit 8-9: opens on rise @ +67 °C $\pm$ 5 °C (+153 °F $\pm$ 9 °F) 11-12: 2.04 to 2.48 k $\Omega$ @ +25 °C $\pm$ 2 °C (+77 °F $\pm$ 4 °F)
4017CH-1	116109	016420-000	1-2: closes on rise @ +57 °C $\pm$ 5 °C (+135 °F $\pm$ 9 °F) 3-4: opens on rise @ +8 °C $\pm$ 5 °C (+46 °F $\pm$ 9 °F)
4050A1-1	114722	017125-000	C-D: closes on rise @ +71 °C $\pm$ 5 °C (+160 °F $\pm$ 9 °F)
4071-1	114722	017125-000	C-D: closes on rise @ +71 °C $\pm$ 5 °C (+160 °F $\pm$ 9 °F)
4071-2	117497	019220-000	A-B: closes on rise @ +57 °C $\pm$ 5 °C (+135 °F $\pm$ 9 °F) C-D: closes on rise @ +71 °C $\pm$ 5 °C (+160 °F $\pm$ 9 °F)
4071-3	-	023046-000	A-B: closes on rise @ +63 °C $\pm$ 5 °C (+146 °F $\pm$ 9 °F) C-D: closes on rise @ +63 °C $\pm$ 5 °C (+146 °F $\pm$ 9 °F)
4071-10	166900	018802-000	A-B: 49.4 to 50.4 K $\Omega$ @ +25 °C $\pm$ 2 °C (+77 °F $\pm$ 4 °F) B-C: 276 to 327 K $\Omega$ @ +25 °C $\pm$ 2 °C (+77 °F $\pm$ 4 °F)

Table 5001 - Sensor connector check (continued)



## INSPECTION/CHECK

Battery description	Sensor (260) P/N (F6177)	Sensor (260) P/N (09052)	Sensor connector check criteria
4076-1	114722	017125-000	C-D: closes on rise @ +71 °C ± 5 °C (+160 °F ± 9 °F)
4076-2	161057	-	C-D: closes on rise @ +57 °C ± 5 °C (+135 °F ± 9 °F)
4076-8	-	019757-000	A-L1: short circuit B-C: 3 KΩ @ +25 °C ± 2 °C (+77 °F ± 4 °F)
4076-9	410929	019756-000	A-C/D-F: 95 to 105 Ω @ +25 °C ± 2 °C (+77 °F ± 4 °F) B-C/E-F: 28 to 32 KΩ @ +25 °C ± 2 °C (+77 °F ± 4 °F)
4076-11	-	019422-000	4-6: short circuit 8-9: opens on rise @ +67.8 °C ± 2.8 °C (+154 °F ± 5 °F) 11-12: 1854 Ω to 3116 Ω @ +22.8 °C ± 5 °C (+73 °F ± 9 °F)
4076-12	-	019498-000	A-B: closes on rise @ +63 °C ± 5 °C (+146 °F ± 9 °F)
4076-13	413861	019504-000	A-B: 171 to 177 Ω @ +24 °C ± 3 °C (+75 °F ± 5 °F) A-B: 197 to 203 Ω @ +60 °C ± 3 °C (+140 °F ± 5 °F) C-D: 171 to 177 Ω @ +24 °C ± 3 °C (+75 °F ± 5 °F) C-D: 197 to 203 Ω @ +60 °C ± 3 °C (+140 °F ± 5 °F)
4076-15	-	023046-000	A-B: closes on rise @ +63 °C ± 5 °C (+146 °F ± 9 °F) C-D: closes on rise @ +63 °C ± 5 °C (+146 °F ± 9 °F)
4076-16	412160	-	A-B: closes on rise @ +71 °C ± 5 °C (+160 °F ± 9 °F)
4076-17	413033 replaced by 416434	-	A-B: 200 Ω @ +60 °C ± 5 °C (+140 °F ± 9 °F) A-B: 174 Ω @ +24 °C ± 3 °C (+75 °F ± 5 °F)
4076-18	-	-	A-B: closes on rise @ +57 °C ± 5 °C (+135 °F ± 9 °F) C-D: closes on rise @ +71 °C ± 5 °C (+160 °F ± 9 °F) D-E: short circuit
4076-19	-	023627-000	A-L1: short circuit B-C: 3 KΩ @ 25 °C (77 °F)
4076-21	412299	-	A-B: closes on rise @ +71 °C ± 5 °C (+160 °F ± 9 °F) C-D: closes on rise @ +71 °C ± 5 °C (+160 °F ± 9 °F) D-E: short circuit
4078-1	114722	017125-000	C-D: closes on rise @ +71 °C ± 5 °C (+160 °F ± 9 °F)
4078-5	117497	019220-000	A-B: closes on rise @ +57 °C ± 5 °C (+135 °F ± 9 °F) C-D: closes on rise @ +71 °C ± 5 °C (+160 °F ± 9 °F)
4078-6	-	019422-000	4-6: 0 Ω @ +23 °C (+73 °F) 8-9: opens on rise @ +67 °C ± 5 °C (+153 °F ± 9 °F) 11-12: 2.04 to 2.48 kΩ @ +25 °C ± 2 °C (+77 °F ± 4 °F)
4078-9	410669	021936-000	A-B: closes on rise @ +57 °C ± 5 °C (+135 °F ± 9 °F) C-D: closes on rise @ +71 °C ± 5 °C (+160 °F ± 9 °F) E-F: 98 Ω @ +20 °C (+68 °F)
4078-10	410929	019756-000	A-C/D-F: 95 to 105 Ω @ +25 °C ± 2 °C (+77 °F ± 4 °F) B-C/E-F: 28 to 32 KΩ @ +25 °C ± 2 °C (+77 °F ± 4 °F)
4078-11	413351	-	A-B: closes on rise @ +57 °C ± 5 °C (+135 °F ± 9 °F) C-D: closes on rise @ +71 °C ± 5 °C (+160 °F ± 9 °F) E-F: 140 Ω @ +25 °C ± 2 °C (+77 °F ± 4 °F)
4078-13	166900	018802-000	A-B: 49.4 to 50.4 KΩ @ +25 °C ± 2 °C (+77 °F ± 4 °F) B-C: 276 to 327 KΩ @ +25 °C ± 2 °C (+77 °F ± 4 °F)
4078-15	413011	-	A-B: opens on rise @ -12 ± 5 °C (+10 °F ± 9 °F) B-C: opens on rise @ -12 ± 5 °C (+10 °F ± 9 °F), R=13 Ω D-E: closes on rise @ +71 °C ± 5 °C (+160 °F ± 9 °F)
4078-16	413339	-	A-B: closes on rise @ +65 °C ± 5 °C (+149 °F ± 9 °F) C-D: closes on rise @ +65 °C ± 5 °C (+149 °F ± 9 °F)
4078-18	412812	024558-000	B-C: closes on rise @ +57 °C ± 5 °C (+135 °F ± 9 °F) E-F: closes on rise @ +57 °C ± 5 °C (+135 °F ± 9 °F)

Table 5001 - Sensor connector check (continued)

## INSPECTION/CHECK

Battery description	Sensor (260) P/N (F6177)	Sensor (260) P/N (09052)	Sensor connector check criteria
4078-19	-	023697-000	A-B: opens on rise @ +71 °C ± 5 °C (+160 °F ± 9 °F) C-D: close after open +60 °C ± 5 °C (+140 °F ± 9 °F)
4078-21	413033 replaced by 416434	-	A-B: 200 Ω @ +60 °C ± 5 °C (+140 °F ± 9 °F) A-B: 174 Ω @ +24 °C ± 3 °C (+75 °F ± 5 °F)
4078-25	415137	-	A: middle point C-D: opens on rise @ +71 °C (+160 °F) E-F: 2.25 KΩ @ +25 °C ± 2 °C (+77 °F ± 4 °F)
4079-1	161057	-	C-D: closes on rise @ +57 °C ± 5 °C (+135 °F ± 9 °F)
4079-2	117497	019220-000	A-B: closes on rise @ +57 °C ± 5 °C (+135 °F ± 9 °F) C-D: closes on rise @ +71 °C ± 5 °C (+160 °F ± 9 °F)
4079-4	-	019757-000	A-L1: short circuit B-C: 3 KΩ @ +25 °C ± 2 °C (+77 °F ± 4 °F)
4079-6	114722	017125-000	C-D: closes on rise @ +71 °C ± 5 °C (+160 °F ± 9 °F)
4079-9	413084	-	A: + B: - C-D: 15 kΩ @ +25 °C ± 2 °C (+77 °F ± 4 °F) E-F: 15 kΩ @ +25 °C ± 2 °C (+77 °F ± 4 °F) G-H: 15 kΩ @ +25 °C ± 2 °C (+77 °F ± 4 °F)
4079-10	-	024979-000	A-B: 255.3 to 344.7 kΩ @ +25 °C ± 2.8 °C (+77 °F ± 5 °F) C-E: close on rise @ +60 °C ± 2.2 °C (+140 °F ± 4 °F) D-F: close on rise @ +71 °C ± 2.8 °C (+160 °F ± 5 °F)
4317CH1	-	016420-000	1-2: closes on rise @ +57 °C ± 5 °C (+135 °F ± 9 °F) 3-4: closes on fall @ +8 °C ± 5 °C (+46 °F ± 9 °F)
4410CH1	415378	-	A-B: closes on rise @ +57 °C ± 5 °C (+135 °F ± 9 °F) C-D: closes on rise @ +71 °C ± 5 °C (+160 °F ± 9 °F)
4417CH14	413861	019504-000	A-B: 171 to 177 Ω @ +24 °C ± 3 °C (+75 °F ± 5 °F) A-B: 197 to 203 Ω @ +60 °C ± 3 °C (+140 °F ± 5 °F) C-D: 171 to 177 Ω @ +24 °C ± 3 °C (+75 °F ± 5 °F) C-D: 197 to 203 Ω @ +60 °C ± 3 °C (+140 °F ± 5 °F)
5035CH4	410218	-	A-B: 276 to 327 KΩ @ +25 °C ± 2 °C (+77 °F ± 4 °F) C-D: closes on rise @ +71 °C ± 5 °C (+160 °F ± 9 °F)
5512CH1	-	022036-000	C-E: 1.98 to 2.02 KΩ @ +25 °C ± 2 °C (+77 °F ± 4 °F) G-+: 0.99 to 1.01 KΩ @ +25 °C ± 2 °C (+77 °F ± 4 °F) C-battery case: > 20 MΩ F-battery case: > 20 MΩ
12277-1	-	017125-000	C-D: closes on rise @ +71 °C ± 5 °C (+160 °F ± 9 °F)
12277-2	-	019787-000	A-B: 30.1 KΩ @ +25 °C ± 2 °C (+77 °F ± 4 °F) A-C: 95 to 105 Ω @ +25 °C ± 2 °C (+77 °F ± 4 °F) B-C: 26 to 34 KΩ @ +25 °C ± 2 °C (+77 °F ± 4 °F) D-E: 30.1 KΩ @ +25 °C ± 2 °C (+77 °F ± 4 °F) D-F: 95 to 105 Ω @ +25 °C ± 2 °C (+77 °F ± 4 °F) E-F: 26 to 34 KΩ @ +25 °C ± 2 °C (+77 °F ± 4 °F)
16106-1	412759	-	A-B: closes on rise @ +71 °C ± 5 °C (+160 °F ± 9 °F) B-C: 0 Ω @ +23 °C (+73 °F)
16108-1	412759	-	A-B: closes on rise @ +71 °C ± 5 °C (+160 °F ± 9 °F) B-C: 0 Ω @ +23 °C (+73 °F)
16156-1	117497	-	A-B: closes on rise @ +57 °C ± 5 °C (+135 °F ± 9 °F) C-D: closes on rise @ +71 °C ± 5 °C (+160 °F ± 9 °F)
16256-3	-	019384-000	A: + B: L3 close on rise @ +71 °C ± 2.8 °C (+160 °F ± 5 °F) C: - D: L3 close on rise @ +60 °C ± 2.2 °C (+140 °F ± 4 °F)

Table 5001 - Sensor connector check (continued)

## INSPECTION/CHECK

Battery description	Sensor (260) P/N (F6177)	Sensor (260) P/N (09052)	Sensor connector check criteria
16258	410922	-	A: middle point B-C: 2.97 to 3.03 K $\Omega$ @ +25 °C $\pm$ 2 °C (+77 °F $\pm$ 4 °F) E-F: closes on rise @ +71 °C $\pm$ 5 °C (+160 °F $\pm$ 9 °F)
20126-2	-	018582-000	A-B: 174 $\Omega$ @ +24 °C (+75 °F) A-B: 200 $\Omega$ @ +60 °C $\pm$ 5 °C (+140 °F $\pm$ 9 °F)
20126-3	-	018581-000	A-B: 174 $\Omega$ @ +24 °C (+75 °F) A-B: 200 $\Omega$ @ +60 °C (+140 °F) C-D: 174 $\Omega$ @ +24 °C (+75 °F) C-D: 200 $\Omega$ @ +60 °C (+140 °F)
23171-4	166900	018802-000	A-B: 49.4 to 50.4 K $\Omega$ @ +25 °C $\pm$ 2 °C (+77 °F $\pm$ 4 °F) B-C: 276 to 327 K $\Omega$ @ +25 °C $\pm$ 2 °C (+77 °F $\pm$ 4 °F)
23175	116312	015949-000	1-2: closes on rise @ +57 °C $\pm$ 5 °C (+135 °F $\pm$ 9 °F)
23176	116312	015949-000	1-2: closes on rise @ +57 °C $\pm$ 5 °C (+135 °F $\pm$ 9 °F)
23376	161297	-	B-E: closes on rise @ +57 °C $\pm$ 5 °C (+135 °F $\pm$ 9 °F) D-L1: short circuit
23476	161057	-	C-D: closes on rise @ +57 °C $\pm$ 5 °C (+135 °F $\pm$ 9 °F)
23478	161057	-	C-D: closes on rise @ +57 °C $\pm$ 5 °C (+135 °F $\pm$ 9 °F)
23491	117497	017753-000	A-B: closes on rise @ +57 °C $\pm$ 5 °C (+135 °F $\pm$ 9 °F) C-D: closes on rise @ +71 °C $\pm$ 5 °C (+160 °F $\pm$ 9 °F)
23491-3	413049	-	A-B: closes on rise @ +57 °C $\pm$ 5 °C (+135 °F $\pm$ 9 °F) C-D: closes on rise @ +71 °C $\pm$ 5 °C (+160 °F $\pm$ 9 °F) E-F: 143 $\Omega$ @ +25 °C $\pm$ 2 °C (+77 °F $\pm$ 4 °F)
23491-4	414890	-	A-B: closes on rise @ +57 °C $\pm$ 5 °C (+135 °F $\pm$ 9 °F) C-D: closes on rise @ +71 °C $\pm$ 5 °C (+160 °F $\pm$ 9 °F) E-F: 143 $\Omega$ @ +25 °C $\pm$ 2 °C (+77 °F $\pm$ 4 °F) G-H: opens on rise @ +8 °C $\pm$ 5 °C (+46 °F $\pm$ 9 °F)
23498-1	117497	019220-000	A-B: closes on rise @ +57 °C $\pm$ 5 °C (+135 °F $\pm$ 9 °F) C-D: closes on rise @ +71 °C $\pm$ 5 °C (+160 °F $\pm$ 9 °F)
23576-1	-	018802-000	A-B: 49.75 K $\Omega$ @ +25 °C $\pm$ 2 °C (+77 °F $\pm$ 4 °F) B-C: 276 to 327 K $\Omega$ @ +25 °C $\pm$ 2 °C (+77 °F $\pm$ 4 °F)
23576-2	-	019493-000	between lugs: opens on rise @ +66 °C $\pm$ 2.2°C (+150 °F $\pm$ 4 °F)
23676-1	166900	018802-000	A-B: 49.4 to 50.4 K $\Omega$ @ +25 °C $\pm$ 2 °C (+77 °F $\pm$ 4 °F) B-C: 276 to 327 K $\Omega$ @ +25 °C $\pm$ 2 °C (+77 °F $\pm$ 4 °F)
23676-2		019747-000	L1: opens on rise @ +65 °C $\pm$ 5 °C (+149 °F $\pm$ 9 °F)
23678-1	162901	-	C-D: closes on rise @ +57 °C $\pm$ 5 °C (+135 °F $\pm$ 9 °F)
23678-2	411345	-	A-C: 108 to 111 $\Omega$ @ +23 °C (+73 °F) B-C: 30 K $\Omega$ @ +23 °C (+73 °F) D-E: 100 $\Omega$ @ +23 °C (+73 °F) E-F: 30 K $\Omega$ @ +23 °C (+73 °F)
23678-3	413031	-	A-B: closes on rise @ +57 °C $\pm$ 5 °C (+135 °F $\pm$ 9 °F) C-D: opens on rise @ +71 °C $\pm$ 5 °C (+160 °F $\pm$ 9 °F)
25106-2	165226	-	A-B: closes on rise @ +57 °C $\pm$ 5 °C (+135 °F $\pm$ 9 °F) C-D: closes on rise @ +71 °C $\pm$ 5 °C (+160 °F $\pm$ 9 °F) F: box
26108-3	414093	-	A-B: closes on rise @ +71 °C $\pm$ 5 °C (+160 °F $\pm$ 9 °F)
26108-4	414137	-	A-B: closes on rise @ +71 °C $\pm$ 5 °C (+160 °F $\pm$ 9 °F) C-D: closes on rise @ +57 °C $\pm$ 5 °C (+135 °F $\pm$ 9 °F)
26108-5	414182	-	A-B: closes on rise @ +71 °C $\pm$ 5 °C (+160 °F $\pm$ 9 °F)
26108-7	415280	-	A-B: closes on rise @ +71 °C $\pm$ 5 °C (+160 °F $\pm$ 9 °F) C-D: 276 to 327 K $\Omega$ @ +25 °C $\pm$ 2 °C (+77 °F $\pm$ 4 °F)
26308-1	114722	017125-000	C-D: closes on rise @ +71 °C $\pm$ 5 °C (+160 °F $\pm$ 9 °F)

Table 5001 - Sensor connector check (continued)

## INSPECTION/CHECK

Battery description	Sensor (260) P/N (F6177)	Sensor (260) P/N (09052)	Sensor connector check criteria
26308-5	166900	018802-000	A-B: 49.4 to 50.4 K $\Omega$ @ +25 °C $\pm$ 2 °C (+77 °F $\pm$ 4 °F) B-C: 276 to 327 K $\Omega$ @ +25 °C $\pm$ 2 °C (+77 °F $\pm$ 4 °F)
26408-1	114722	017125-000	C-D: closes on rise @ +71 °C $\pm$ 5 °C (+160 °F $\pm$ 9 °F)
26508-1	116051	-	A-B: closes on rise @ +71 °C $\pm$ 5 °C (+160 °F $\pm$ 9 °F) C-D: short circuit
27168-1	411345	-	A-C: 108 to 111 $\Omega$ @ +25 °C $\pm$ 2 °C (+77 °F $\pm$ 4 °F) B-C: 30 K $\Omega$ @ +25 °C $\pm$ 2 °C (+77 °F $\pm$ 4 °F) D-F: 100 $\Omega$ @ +25 °C $\pm$ 2 °C (+77 °F $\pm$ 4 °F) E-F: 30 K $\Omega$ @ +25 °C $\pm$ 2 °C (+77 °F $\pm$ 4 °F)
27278-2	117497	017753-000	A-B: closes on rise @ +57 °C $\pm$ 5 °C (+135 °F $\pm$ 9 °F) C-D: closes on rise @ +71 °C $\pm$ 5 °C (+160 °F $\pm$ 9 °F)
27478	412804	-	A-E: opens on rise @ +12 °C $\pm$ 5 °C (+54 °F $\pm$ 9 °F) E-F: opens on rise @ +12 °C $\pm$ 5 °C (+54 °F $\pm$ 9 °F), R = 22 $\Omega$ $\pm$ 2 $\Omega$ B-C: opens on rise @ +71 °C $\pm$ 5 °C (+160 °F $\pm$ 9 °F) G-H: 96 $\Omega$ to 99 $\Omega$ @ +20 °C $\pm$ 2 °C (+68 °F $\pm$ 3.6 °F)
27578-2	117497	019220-000	A-B: closes on rise @ +57 °C $\pm$ 5 °C (+135 °F $\pm$ 9 °F) C-D: closes on rise @ +71 °C $\pm$ 5 °C (+160 °F $\pm$ 9 °F)
40100-1	114722	017125-000	C-D: closes on rise @ +71 °C $\pm$ 5 °C (+160 °F $\pm$ 9 °F)
40176-10	-	023172-000	
40178-7	410669	021564-000	A-B: closes on rise @ +57 °C $\pm$ 5 °C (+135 °F $\pm$ 9 °F) C-D: closes on rise @ +71 °C $\pm$ 5 °C (+160 °F $\pm$ 9 °F) E-F: 91 $\Omega$ @ 0 °C (+32 °F)
40178-21	413033 replaced by 416410	-	A-B: 200 $\Omega$ @ +60 °C $\pm$ 5 °C (+140 °F $\pm$ 9 °F) A-B: 174 $\Omega$ @ +24 $\pm$ 3 °C (+75 $\pm$ 5 °F)
40179-7	116109	016420-000	1-2: closes on rise @ +57 °C $\pm$ 5 °C (+135 °F $\pm$ 9 °F) 3-4: opens on rise @ +8 °C $\pm$ 5 °C (+46 °F $\pm$ 9 °F)
40200-1	413455	-	A-B: closes on rise @ +57 °C $\pm$ 5 °C (+135 °F $\pm$ 9 °F) C-D: closes on rise @ +71 °C $\pm$ 5 °C (+160 °F $\pm$ 9 °F)
40206-2	114722	017125-000	C-D: closes on rise @ +71 °C $\pm$ 5 °C (+160 °F $\pm$ 9 °F)
40208-1	166854	-	A-B: 111 $\Omega$ $\pm$ 4 $\Omega$ @ +20 °C $\pm$ 2 °C (+68 °F $\pm$ 3.6 °F) B-C: 111 $\Omega$ $\pm$ 4 $\Omega$ @ +20 °C $\pm$ 2 °C (+68 °F $\pm$ 3.6 °F)
40208-2	114722	017125-000	C-D: closes on rise @ +71 °C $\pm$ 5 °C (+160 °F $\pm$ 9 °F)
40208-4	410718	-	A-B: T1 OPEN @ -12 °C (-56 °F) A-B: R1 23 $\Omega$ @ +23 °C (+73 °F)
40208-5	411124	-	A-B: 107 to 115 $\Omega$ @ +20 °C $\pm$ 2 °C (+68 °F $\pm$ 3.6 °F) B-C: 107 to 115 $\Omega$ @ +20 °C $\pm$ 2 °C (+68 °F $\pm$ 3.6 °F) D-E: opens on rise @ -5 °C (+23 °F) E-F: opens on rise @ -15 °C (+5 °F) with R = 20.7 to 25.3 $\Omega$
40208-6	411980	-	A-B: 32.7 to 33.3 k $\Omega$ @ +25 °C $\pm$ 2 °C (+77 °F $\pm$ 4 °F) C: middle point E-F: closes on rise @ +71 °C $\pm$ 5 °C (+160 °F $\pm$ 9 °F)
40208-7	413455	-	A-B: closes on rise @ +57 °C $\pm$ 5 °C (+135 °F $\pm$ 9 °F) C-D: closes on rise @ +71 °C $\pm$ 5 °C (+160 °F $\pm$ 9 °F)
40209-2	166900	018802-000	A-B: 49.4 to 50.4 K $\Omega$ $\pm$ @ +25 °C $\pm$ 2 °C (+77 °F $\pm$ 4 °F) B-C: 276 to 327 K $\Omega$ @ +25 °C $\pm$ 2 °C (+77 °F $\pm$ 4 °F)
40278-2	117497	019220-000	A-B: closes on rise @ +57 °C $\pm$ 5 °C (+135 °F $\pm$ 9 °F) C-D: closes on rise @ +71 °C $\pm$ 5 °C (+160 °F $\pm$ 9 °F)
40278-14	413861	019504-000	A-B: 171 to 177 $\Omega$ @ +24 °C $\pm$ 3 °C (+75 °F $\pm$ 5 °F) A-B: 197 to 203 $\Omega$ @ +60 °C $\pm$ 3 °C (+140 °F $\pm$ 5 °F) C-D: 171 to 177 $\Omega$ @ +24 °C $\pm$ 3 °C (+75 °F $\pm$ 5 °F) C-D: 197 to 203 $\Omega$ @ +60 °C $\pm$ 3 °C (+140 °F $\pm$ 5 °F)

Table 5001 - Sensor connector check (continued)

INSPECTION/CHECK

Battery description	Sensor (260) P/N (F6177)	Sensor (260) P/N (09052)	Sensor connector check criteria
40478-1	-	021613-000	A-B: opens on rise @ +60 °C ± 5 °C (+140 °F ± 9 °F) D-G: opens on rise @ +65 °C ± 5 °C (+149 °F ± 9 °F) E-F: 2.04 to 2.48 kΩ @ +25 °C ± 2 °C (+77 °F ± 4 °F)
40508-1	410929	019756-000	A-C/D-F: 95 to 105 Ω @ +25 °C ± 2 °C (+77 °F ± 4 °F) B-C/E-F: 28 to 32 KΩ @ +25 °C ± 2 °C (+77 °F ± 4 °F)
40576-3	-	017694-000	BC: 3 KΩ @ +25 °C ± 2 °C (+77 °F ± 4 °F)
40576-14	-	017446-000	A-B: 49.75 KΩ @ +25 °C ± 2 °C (+77 °F ± 4 °F) B-C: 276 to 327 KΩ @ +25 °C ± 2 °C (+77 °F ± 4 °F)
40678-1	-	017446-000	A-B: 49.75 KΩ @ +25 °C ± 2 °C (+77 °F ± 4 °F) B-C: 276 to 327 KΩ @ +25 °C ± 2 °C (+77 °F ± 4 °F)
40678-4	-	023451-000	A-CONN: closes on rise @ +60 °C ± 5 °C (+140 °F ± 9 °F) C-CONN: closes on rise @ +71 °C ± 5 °C (+160 °F ± 9 °F) E-F: 0.93 to 1.07 KΩ ± 70 Ω @ +25 °C ± 2 °C (+77 °F ± 4 °F)
40778-11	413351	-	A-B: closes on rise +57 °C ± 5 °C (+135 °F ± 9 °F) C-D: closes on rise @ +71 °C ± 5 °C (+160 °F ± 9 °F) E-F: 140 Ω @ +25 °C ± 2 °C (+77 °F ± 4 °F)
40876-10	-	017446-000	A-B: 49.75 KΩ @ +25 °C ± 2 °C (+77 °F ± 4 °F) B-C: 276 to 327 KΩ @ +25 °C ± 2 °C (+77 °F ± 4 °F)
401076	-	019640-000	A-C: closes on rise @ +71 °C ± 5 °C (+160 °F ± 9 °F)
A2609-1	416275	-	A-B: closes on rise @ +71 °C ± 5 °C (+160 °F ± 9 °F) C-D: closes on rise @ +57 °C ± 5 °C (+135 °F ± 9 °F) E-F: 169 to 179 Ω ± 5 Ω @ +24 °C ± 3 °C (+75 °F ± 5 °F) E-F: 199.5 to 200.5 Ω @ +60 °C ± 1 °C (+140 °F ± 2 °F)
A26908	415537	-	A-B: closes on rise @ +57 °C ± 5 °C (+135 °F ± 9 °F) C-D: closes on rise @ +71 °C ± 5 °C (+160 °F ± 9 °F)
A275CH1	415826	-	A-C: opens on rise @ +71 °C ± 5 °C (+160 °F ± 9 °F) A-B: 2043 Ω to 2717 Ω @ +24 °C ± 3 °C (+75 °F ± 5 °F)
A40209-1	413175	-	B-C: closes on rise @ +71 °C ± 5 °C (+160 °F ± 9 °F) B-D: short circuit
A407CH	412299	-	A-B: closes on rise @ +71 °C ± 5 °C (+160 °F ± 9 °F) C-D: closes on rise @ +71 °C ± 5 °C (+160 °F ± 9 °F) D-E: short circuit
A407CH-3	412299	-	A-B: closes on rise @ +71 °C ± 5 °C (+160 °F ± 9 °F) C-D: closes on rise @ +71 °C ± 5 °C (+160 °F ± 9 °F) D-E: short circuit
A4076-21	412299	-	A-B: closes on rise @ +71 °C ± 5 °C (+160 °F ± 9 °F) C-D: closes on rise @ +71 °C ± 5 °C (+160 °F ± 9 °F) D-E: short circuit
A4078-12	412299	-	A-B: closes on rise @ +71 °C ± 5 °C (+160 °F ± 9 °F) C-D: closes on rise @ +71 °C ± 5 °C (+160 °F ± 9 °F) D-E: short circuit
B153CH1	415445	-	A-B: opens on rise @ +71 °C ± 5 °C (+160 °F ± 9 °F) C: middle point with 4.99 KΩ 1% resistor D-E: opens on rise @ +8 °C ± 5 °C (+46 °F ± 9 °F) D-F: opens on rise @ +8 °C ± 5 °C (+46 °F ± 9 °F) with 13 Ω resistor
B1513CH1	415445	-	A-B: opens on rise @ +71 °C ± 5 °C (+160 °F ± 9 °F) C: middle point with 4.99 KΩ 1% resistor D-E: opens on rise @ +8 °C ± 5 °C (+46 °F ± 9 °F) D-F: opens on rise @ +8 °C ± 5 °C (+46 °F ± 9 °F) with 13 Ω resistor

Table 5001 - Sensor connector check (continued)

## INSPECTION/CHECK

## 8-4. Vent-valve test

**NOTE:** The Vent-valve test is not necessary if the full set of used vent-valves is replaced by a brand new one each year during the [General overhaul](#) or when there is evidence of electrolyte overflow.

**NOTE:** Vent-valves should be cleaned before testing (refer to [Vent-valves cleaning](#)).

**NOTE:** If the vent-valve does not open during the test, increase the pressure slowly until the vent-valve opens (one time, to 1.4 bar or (20 psi) maximum) to ensure functionality, then repeat the full test.

This test should be done while the battery is on charge.

Check the operation of the vent-valve assembly as follows:

- Put the vent-valve assembly (160) with its O-ring finger tight into the vent-valve adapter (T05\*) of the pressure test fixture.
- Immerse the vent-valve assembly (160) in water and slowly raise the air pressure.
- Test according to the table below, and change all vent-valves if they do not pass the test.

Test	Check
O-ring	No distortion, split, or cracks
Air pressure < 0.14 bar (2 psi)	Vent-valve is closed (no bubbles observed)
0.14 bar (2 psi) < air pressure < 0.7 bar (10 psi)	Vent-valve opens (bubbles observed)

Table 5002 - Vent-valve test

## ASSEMBLY

### 1. Introduction

This section covers basic battery assembly procedures. In all cases, when reassembling a battery, all components should be clean and dry.

### 2. Safety

Refer to chapter [Safety](#) in [INTRODUCTION](#).

### 3. Equipment

#### 3-1. Standard tools

Refer to chapter [Standard tools](#) in [SPECIAL TOOLS, FIXTURES, EQUIPMENT AND CONSUMABLES](#).

#### 3-2. Special tools

When special tools are used in this chapter, they are identified by a code number listed in [SPECIAL TOOLS, FIXTURES, EQUIPMENT AND CONSUMABLES](#) chapter.

### 4. Battery assembly

**NOTE:** All (###) part identification numbers herein are IPL Figure [10001 - Ni-Cd aircraft battery](#) item numbers.

#### 4-1. Installation of the sensor connector complete (if applicable)

**CAUTION:** CARE MUST BE TAKEN NOT TO PULL ON WIRES, TWIST OR BEND THE HEATER TABS (IF APPLICABLE) BACK AND FORTH.

**CAUTION:** DO NOT PINCH CABLE HARNESS AGAINST SHARP EDGES.

**NOTE:** Handle sensor connector complete with care to prevent damage to the temperature sensors and heater tabs (if applicable)

**NOTE:** (If applicable) The heaters will be installed once the liner-spacer kit ([200](#)) is in place. Do not install heaters at this time.

**NOTE:** Some temperature sensors and/or heater blankets include components that require installation between cells and/or within the battery box. Ensure these items are installed properly prior to the first cell in each row being installed.

Install the sensor connector complete ([260](#)) on the box assembly ([020](#)) opening using the proper hardware.

Lubricate any temperature sensor nuts using [M02](#).

Install the temperature sensors on the appropriate links ([030](#) to [095](#)) using the proper hardware.

Carefully set the wire harness and heater blankets (if applicable) outside of the battery box assembly ([020](#)).

#### 4-2. Installation of the power connector complete

Install the power connector complete ([230](#)) and gasket ([-240](#)) from outside the box assembly ([020](#)) into position with the screws ([210](#)) and the washers ([220](#)) assemblies per figure [10001 - Ni-Cd aircraft battery](#).

Install the power connector cover ([235](#)). - if available-

**NOTE:** Remove power connector cover before flight.

## ASSEMBLY

## 4-3. Installation of the one-way valve (if applicable)

**CAUTION: THE ONE-WAY VALVE MUST BE INSTALLED, ORIENTED PROPERLY, AND MUST NOT TOUCH OTHER COMPONENTS; SENSOR CONNECTOR HARNESS OR METAL SPACER. REFER TO FIGURE [7001 - One-way valve installation](#)**

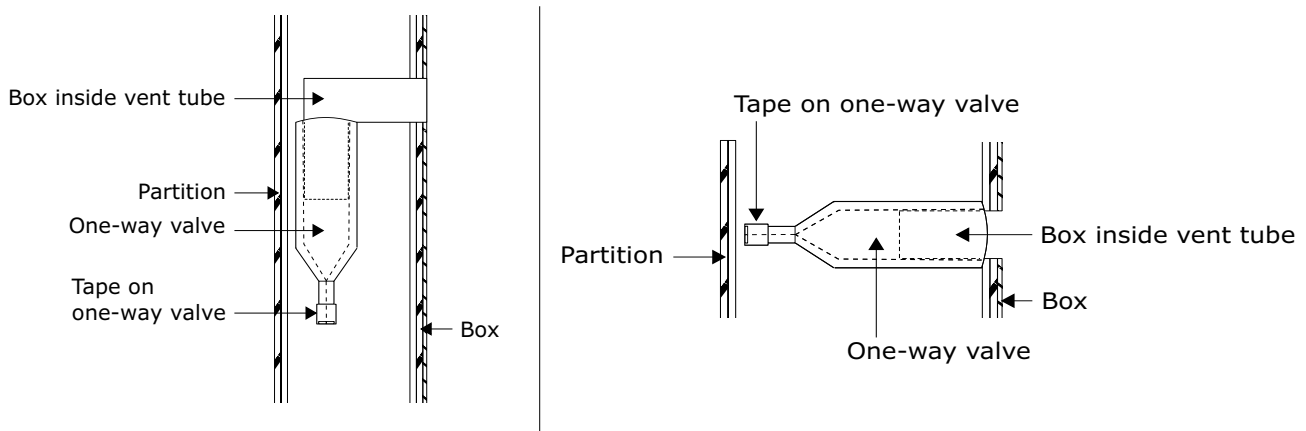

**Figure 7001 - One-way valve installation**

Install the one-way valve (-270) on battery box assembly (020) vent tube per figure [7001 - One-way valve installation](#).

Install the metal spacer inside the box assembly (020) in front of the one-way valve.

## 4-4. Installation of the liner-spacer kit

**CAUTION: SOME LINERS OR SPACERS ARE SLOTTED. MAKE SURE THE VENT TUBES OF THE BOX IS UNOBSTRUCTED.**

**NOTE: To facilitate liner-spacer kit (200) placement, place cell assemblies (100) at both ends of each row.**

**NOTE: Liner-spacer kit (200) is used to make sure the cell assembly (100) are tightly held in place. Adjust liner-spacer count as required.**

Put the liner-spacer kit (200) in the battery box assembly (020).

(if applicable) Install the heaters.

## 4-5. Installation of the cell assembly

**CAUTION: MAKE SURE CELL POLARITY IS CORRECT, DOUBLE CHECK CELL ORIENTATION PER table [Battery connection layouts](#).**

**NOTE: To facilitate cell installation and make sure cell orientation is respected, first layout the cells outside the box per table [Battery connection layouts](#).**

Insert the cell assemblies (100) in the battery box assembly (020) making sure to maintain proper polarity. For easier installation, the center cell in each row should be the last one installed. Press firmly on the last cell in each row with a block of soft wood to seat it firmly in position.

**NOTE: Torque the lower nuts (115) according to [FITS AND CLEARANCES](#) chapter.**

Lightly lubricate the terminals and the links (030 to 095) with M02 (use a non-metallic paintbrush).

Lightly lubricate the upper nuts (110) and the washers (120) with M02 (use a non-metallic paintbrush).

Put the links (030 to 095), the washers (120), and the nuts (110 and 115) on the cell terminals.

Torque the upper nuts (110) to desired torque (refer to [FITS AND CLEARANCES](#) chapter).

Install cable ties (-250) (if applicable) making sure wire harness cables are not pinched.

## 4-6. Installation of the cover complete

Put the cover complete (010) on the battery and secure it with the retaining latches.

## 4-7. Recording

Fill out the log book (or equivalent).



## FITS AND CLEARANCES

### 1. Introduction

The table [8002 - Battery specifications](#) in this section is designed to provide basic information about each battery. The table includes the capacity rating necessary for charge and discharge procedures, the type of cells, the torque values for each cell type and important electrolyte volume and consumable volume information. A legend is provided below that contains the power connector type codes.

The torque values in tables [8002 - Battery specifications](#) and [8004 - BAC102 power connector torque values](#) are lubricated torque values. The thread of the terminals and attaching nuts should be lightly coated with a neutral petroleum jelly ([M02](#)) prior to assembly and applying torque.

The “electrolyte level” corresponds to the height between the valve seat (without the O-ring) and the electrolyte level at the end of charge. It is equivalent to the length of the nozzle to use to do the electrolyte level.

### 2. Power connector types

Power connector type	Description
A	ARINC 404
B	Cannon CA.3102.R.24.9S.F80
C	Female threaded M8 x 1.25
D	EN2570 fig. 2 & 3; <a href="#">BAC102 power connector assembly</a>
E	MIL B 83769 fig. 2
F	ISO 5064-2 or MS 3509 style
G	Non-standard
H	MIL C 5015
I	Non-standard
J	Non-standard
K	Special, contact factory 72-19-4
L	Russian standard

**Table 8001 - Power connector types**

3. Battery specifications

Battery	Number of cells	Cell type	Rated capacity C <sub>10</sub> A (Ah)	Dimension mm (in)	Weight kg (lbs)	Power connector type	Lower Nut torque value N.m (lbf.in)	Upper Nut torque value N.m (lbf.in)	Nozzle length mm	Electrolyte water volume cm <sup>3</sup>
19VO23KHB	19	<a href="#">VO3KHB</a>	3	254x109x106 (10x4.3x4.2)	3.9 (8.6)	<a href="#">G</a>	1 to 2 (17 to 18)	2.95 to 3.05 (22 to 30)	20	5
20VO3KHB	20	<a href="#">VO3KHB</a>	3	254x109x106 (10x4.3x4.2)	4.1 (9)	<a href="#">G</a>	1 to 2 (17 to 18)	2.95 to 3.05 (22 to 30)	20	5
25HV01.1	25	<a href="#">HVO1.1</a>	11	117.9x86.6x84.3 (4.64x3.41x3.32)	2.6 (5.8)	<a href="#">G</a>	0.5 (4.4)	1 (8.7)	-	-
151CH2	20	<a href="#">CVH150KH</a>	15	306.5x139.5x210	15.2 (33.5)	<a href="#">J</a>	4.5 to 5.5 (39.8 to 48.7)	7 to 9 (62 to 80)	20	15
176CH	20	<a href="#">CVH170KA</a>	17	322.6x163.1x200.0 (12.7x6.4x7.9)	18.1 (40.3)	<a href="#">F</a>	4.5 to 5.5 (39.8 to 48.7)	7 to 9 (62 to 80)	20 MS	30
176CH6	20	<a href="#">CVH170KA</a>	17	294.7x176.8x206.5 (11.60x6.61x8.13)		<a href="#">F</a>	4.5 to 5.5 (39.8 to 48.7)	7 to 9 (62 to 80)	20 MS	30
178CH1	20	<a href="#">CVH170KA</a>	17	301.6x169.0x208.0 (11.87x6.65x8.19)	18.3 (40.3)	<a href="#">F</a>	4.5 to 5.5 (39.8 to 48.7)	7 to 9 (62 to 80)	20 MS	30
181CH	20	<a href="#">CVH180KH</a>	18	310.0x167.0x200.0 (12.20x6.83x7.87)	18.5 (40.78)	<a href="#">G</a>	4.5 to 5.5 (39.8 to 48.7)	7 to 9 (62 to 80)	20	12
187CH	20	<a href="#">CVH180KH</a>	18	223.0x244.0x171.0 (8.78x9.61x6.73)	18.5 (40.78)	<a href="#">G</a>	4.5 to 5.5 (39.8 to 48.7)	9.6 (83.5)	20	12
272CH1	20	<a href="#">CVH271KH</a>	27	350x140.0x254.0 (13.79x5.51x10.0)	23.9 (52.7)	<a href="#">G</a>	4.5 to 5.5 (39.8 to 48.7)	7 to 9 (62 to 80)	20	21
276CH	20	<a href="#">CVH271KH</a>	27	254.0x198.0x224.0 (10.00x7.80x8.82)	25.2 (55.5)	<a href="#">G</a>	4.5 to 5.5 (39.8 to 48.7)	7 to 9 (62 to 80)	20	21
276CH7	20	<a href="#">CVH271KH</a>	27	276.0x250.0x226.0	25.5 (56)	<a href="#">F</a>	4.5 to 5.5 (39.8 to 48.7)	7 to 9 (62 to 80)	20	21
276CH10	20	<a href="#">CVH271KH</a>	27	276.0x250.0x226.0	25.4 (56)	<a href="#">F</a>	4.5 to 5.5 (39.8 to 48.7)	7 to 9 (62 to 80)	20	21
276CH23	20	<a href="#">CVH271KH</a>	27	276.0x250.0x22.06	25.4 (56)	<a href="#">F</a>	4.5 to 5.5 (39.8 to 48.7)	7 to 9 (62 to 80)	20	21
277CH1	20	<a href="#">CVH271KH</a>	27	254.0x198.0x224.0 (10.00x7.80x8.82)	25.2 (55.5)	<a href="#">G</a>	4.5 to 5.5 (39.8 to 48.7)	7 to 9 (62 to 80)	20	21
310VX2	20	<a href="#">VXP310KH</a>	31	420.0x216.0x250.0	32.6 (71.9)	<a href="#">G</a>	4.5 to 5.5 (39.8 to 48.7)	7 to 9 (62 to 80)	20	25
340CD	20	<a href="#">CVD34KH</a>	32	407.5x120.5x211.0 (16.04x4.74x8.31)	24.1 (53.1)	<a href="#">G</a>	4.5 to 5.5 (39.8 to 48.7)	7 to 9 (62 to 80)	20	20
340CD-2	20	<a href="#">CVD34KH</a>	32	407.5x120.5x211.0 (16.04x4.74x8.31)	24.1 (53.1)	<a href="#">G</a>	4.5 to 5.5 (39.8 to 48.7)	7 to 9 (62 to 80)	20	20
345CD1	20	<a href="#">CVD34KH</a>	32	407.5x120.5x211.0 (16.04x4.74x8.31)	24.1 (53.1)	<a href="#">G</a>	4.5 to 5.5 (39.8 to 48.7)	7 to 9 (62 to 80)	20	20
438CH2		<a href="#">CVH430KA</a>	43	261.4x300.0x261.9 (10.29x11.81x10.31)		<a href="#">G</a>	4.5 to 5.5 (39.8 to 48.7)	7 to 9 (62 to 80)	20 MS	70

Table 8002 - Battery specifications

## FITS AND CLEARANCES

Battery	Number of cells	Cell type	Rated capacity C <sub>10</sub> (Ah)	Dimension mm (in)	Weight kg (lbs)	Power connector type	Lower Nut torque value N.m (lbf.in)	Upper Nut torque value N.m (lbf.in)	Nozzle length mm	Electrolyte water volume cm <sup>3</sup>
405CH3	20	<a href="#">CVH400KA</a>	40	269.0x300.x262.0	35.0 (77.2)	D	4.5 to 5.5 (39.8 to 48.7)	12.4 to 13 (110 to 115)	20 MS	60
407CH2	20	<a href="#">CVH400KA</a>	40	254.0x248.0x262.0 (10.00x9.76x10.31)	34.0 (75.0)	G	4.5 to 5.5 (39.8 to 48.7)	12.4 to 13 (110 to 115)	20 MS	60
407CH5	20	<a href="#">CVH400KA</a>	40	268.4x300.0x262.0 (10.57x25.44x10.31)	34.8 (78.8)	G	4.5 to 5.5 (39.8 to 48.7)	12.4 to 13 (110 to 115)	20 MS	60
407CH9	20	<a href="#">CVH400KA</a>	40	254.0x248.0x262.0 (10.00x9.76x10.31)	35.4 (78.0)	F	4.5 to 5.5 (39.8 to 48.7)	12.4 to 13 (110 to 115)	20 MS	60
407CH11	20	<a href="#">CVH400KA</a>	40	248.4x254.0x254.0 (9.78x10.00x254.0)	35.8 (79.0)	G	4.5 to 5.5 (39.8 to 48.7)	12.4 to 13 (110 to 115)	20 MS	60
407CH13	20	<a href="#">CVH400KA</a>	40	248.4x254.0x254.0 (9.78x10.00x254.0)	34.6 (76.0)	G	4.5 to 5.5 (39.8 to 48.7)	12.4 to 13 (110 to 115)	20 MS	60
407CH19	20	<a href="#">CVH400KA</a>	40	254.0x248.0x262.0 (10.00x9.76x10.31)	35.8 (79.0)	G	4.5 to 5.5 (39.8 to 48.7)	12.4 to 13 (110 to 115)	20 MS	60
437CH14	20	<a href="#">CVH430KA</a>	40	248.4x254.0x254.0 (9.78x10.00x254.0)	34.6 (76.0)	G	4.5 to 5.5 (39.8 to 48.7)	7 to 9 (62 to 80)	20 MS	70
442CH2	20	<a href="#">CVH441KH</a>	44	363.0x169.0x270.0 (6.65x10.63x81.6)	37.0 (81.6)	G	4.5 to 5.5 (39.8 to 48.7)	12 to 14 (106 to 124)	20	25
447CH1	20	<a href="#">CVH441KH</a>	44	268.4x300.0x262.0 (10.57x11.81x10.31)	37.2 (82)	F	4.5 to 5.5 (39.8 to 48.7)	12 to 14 (106 to 124)	20	25
447CH3	20	<a href="#">CVH441KH</a>	44	279.5x302.0x262.0 (11.00x11.89x10.31)	37.0 (81.6)	F	4.5 to 5.5 (39.8 to 48.7)	12 to 14 (106 to 124)	20	25
447CH8	20	<a href="#">CVH441KH</a>	44	274.0x302.0x262.0 (10.78x11.81x10.31)	37.2 (81.6)	F	4.5 to 5.5 (39.8 to 48.7)	12 to 14 (106 to 124)	20	25
606	20	<a href="#">VP65K</a>	6	366x125.5x155.5	9.1 (20.1)	I	4.5 to 5.5 (39.8 to 48.7)	7 to 9 (62 to 80)	17	8
615	19	<a href="#">VP65K</a>	6	267.7x117.5x121.0	7.8 (17.1)	I	4.5 to 5.5 (39.8 to 48.7)	7 to 9 (62 to 80)	17	8
616	20	<a href="#">VP65K</a>	6	267.7x117.5x121.0	8.0 (17.6)	I	4.5 to 5.5 (39.8 to 48.7)	7 to 9 (62 to 80)	17	8
653	21	<a href="#">VP65K</a>	6	204.0x168.0x142.0	8.9 (19.6)	I	4.5 to 5.5 (39.8 to 48.7)	7 to 9 (62 to 80)	17	8
666	20	<a href="#">VP65K</a>	6	177.0x174.0x158.0	8.2 (17.8)	I	4.5 to 5.5 (39.8 to 48.7)	7 to 9 (62 to 80)	17	8
1277	19	<a href="#">VP120KH-MS</a>	14	193.5x197.0x198.4 (7.62x7.75x7.81)	15.3x33.7	F	-	2.5 to 3.5 (22 to 31)	24	15
1277-1	19	<a href="#">VP120KHB</a>	14	193.5x197.0x198.4 (7.62x7.75x7.81)	15.3x33.7	F	-	2.5 to 3.5 (22 to 31)	24 MS	15
1277-2	19	<a href="#">VP120KHB</a>	14	193.5x197.0x198.4 (7.62x7.75x7.81)	15.3x33.7	F	-	2.5 to 3.5 (22 to 31)	24 MS	15
1277-3	19	<a href="#">VP120KHB</a>	14	193.5x197.0x198.4 (7.62x7.75x7.81)	15.3x33.7	F	-	2.5 to 3.5 (22 to 31)	24 MS	15

Table 8002 - Battery specifications

FITS AND CLEARANCES

Battery	Number of cells	Cell type	Rated capacity C <sub>10</sub> A (Ah)	Dimension mm (in)	Weight kg (lbs)	Power connector type	Lower Nut torque value N.m (lbf.in)	Upper Nut torque value N.m (lbf.in)	Nozzle length mm	Electrolyte water volume cm <sup>3</sup>
1606	20	<a href="#">VP160KM</a>	16	370.0x118.6x204.5	17.3 (38.1)	C	4.5 to 5.5 (39.8 to 48.7)	7 to 9 (62 to 80)	20	20
1608	20	<a href="#">VHP170KH-3</a>	17	370.0x118.6x207.5	17.8 (39.2)	C	4.5 to 5.5 (39.8 to 48.7)	7 to 9 (62 to 80)	20	20
1608-1	20	<a href="#">VHP170KH-3</a>	17	370.0x120.1x207.5	17.7 (39)	I	4.5 to 5.5 (39.8 to 48.7)	7 to 9 (62 to 80)	20	20
1656	20	<a href="#">VP160KH</a>	15	271.6x163.6x205.0	17.4 (38.3)	F	4.5 to 5.5 (39.8 to 48.7)	7 to 9 (62 to 80)	20	20
1656-1	20	<a href="#">VP160KH</a>	15	271.6x163.6x205.0	17.4 (38.6)	F	4.5 to 5.5 (39.8 to 48.7)	7 to 9 (62 to 80)	20	20
1656-2	20	<a href="#">VP160KH</a>	15	271.6x163.6x205.0	17.4 (38.6)	F	4.5 to 5.5 (39.8 to 48.7)	7 to 9 (62 to 80)	20	20
1656-5	20	<a href="#">VP160KH-SQ</a>	15	271.6x163.6x205.0	17.9 (39.5)	F	4.5 to 5.5 (39.8 to 48.7)	7 to 9 (62 to 80)	33	8
1658	20	<a href="#">VHP170KH-3</a>	17	271.6x163.6x205.0	17.8 (39.2)	F	4.5 to 5.5 (39.8 to 48.7)	7 to 9 (62 to 80)	20	20
1658-2	20	<a href="#">VHP170KH-3</a>	17	271.6x163.6x205.0	17.8 (39.2)	F	4.5 to 5.5 (39.8 to 48.7)	7 to 9 (62 to 80)	20	20
1666	20	<a href="#">VP160KM</a>	15	233.5x181.0x195.0	17.0 (37.5)	C	4.5 to 5.5 (39.8 to 48.7)	7 to 9 (62 to 80)	20	20
1666-1	20	<a href="#">VP160KM</a>	15	233.5x181.0x195.0	17.0 (37.5)	C	4.5 to 5.5 (39.8 to 48.7)	7 to 9 (62 to 80)	20	20
1718	10	<a href="#">VHP170KH-3</a>	17	206.0x126.0x187.0	10.7 (23.6)	G	4.5 to 5.5 (39.8 to 48.7)	7 to 9 (62 to 80)	20	20
1756	20	<a href="#">VP170KH</a>	17	322.6x163.1x199.9	18.1 (39.9)	G	4.5 to 5.5 (39.8 to 48.7)	7 to 9 (62 to 80)	20	20
1756-2	20	<a href="#">VP170KH</a>	17	322.6x163.1x199.9	18.1 (39.9)	G	4.5 to 5.5 (39.8 to 48.7)	7 to 9 (62 to 80)	20*	20
1758	20	<a href="#">VHP170KH-3</a>	17	308.3x163.1x199.9	18.1 (39.9)	G	4.5 to 5.5 (39.8 to 48.7)	7 to 9 (62 to 80)	20	20
1811CH	20	CVH180SK	18	310.0x167.0x200.0 (12.2x6.83x6.7)	18.3 (40.4)	I	4.5 to 5.5 (39.8 to 48.7)	7 to 9 (62 to 80)	20	12
2026	20	<a href="#">VP200KHB</a>	22	298.5x245.1x165.1 (11.75x9.65x6.50)	23.7 (52.5)	F	-	4 (40.0)	24	33
2318	20	<a href="#">VHP230KA3</a>	23	427.0x154.0x214.9	23.7 (52.5)	C	4.5 to 5.5 (39.8 to 48.7)	7 to 9 (62 to 80)	20	60
2353	19	<a href="#">VO23KH</a>	23	252.6x194.6x228.0	23.2 (51.1)	E	4.5 to 5.5 (39.8 to 48.7)	7 to 9 (62 to 80)	20	21
2353-1	19	<a href="#">VO23KH</a>	23	252.6x194.6x228.0	23.2 (51.1)	E	4.5 to 5.5 (39.8 to 48.7)	7 to 9 (62 to 80)	20	21
2371	20	<a href="#">VO23KH</a>	23	249.2x268.4x224.0	25.4 (54)	F	4.5 to 5.5 (39.8 to 48.7)	7 to 9 (62 to 80)	20	21

Table 8002 - Battery specifications

FITS AND CLEARANCES

Battery	Number of cells	Cell type	Rated capacity C <sub>10</sub> (Ah)	Dimension mm (in)	Weight kg (lbs)	Power connector type	Lower Nut torque value N.m (lbf.in)	Upper Nut torque value N.m (lbf.in)	Nozzle length mm	Electrolyte water volume cm <sup>3</sup>
2371-1	20	<a href="#">VO23KH</a>	23	249.2x276.0x224.0	24.5 (54)	F	4.5 to 5.5 (39.8 to 48.7)	7 to 9 (62 to 80)	20	21
2371-2	20	<a href="#">VO23KH</a>	23	249.2x276.0x224.0	24.5 (54)	F	4.5 to 5.5 (39.8 to 48.7)	7 to 9 (62 to 80)	20	21
2371-4	20	<a href="#">VO23KH</a>	23	249.2x276.0x224.0	25.4 (54)	F	4.5 to 5.5 (39.8 to 48.7)	7 to 9 (62 to 80)	20	21
2371-5	20	<a href="#">VO23KH</a>	23	249.2x276.0x224.0	24.9 (54.9)	F	4.5 to 5.5 (39.8 to 48.7)	7 to 9 (62 to 80)	20	21
2371-6	20	<a href="#">VO23KH</a>	23	249.2x276.0x224.0	24.5 (54)	F	4.5 to 5.5 (39.8 to 48.7)	7 to 9 (62 to 80)	20	21
2371-7	20	<a href="#">VO23KH</a>	23	249.2x276.0x224.0	24.5 (54)	F	4.5 to 5.5 (39.8 to 48.7)	7 to 9 (62 to 80)	20	21
2376	20	<a href="#">VP230KH</a>	22	249.2x268.4x224.0	25.5 (56.2)	F	4.5 to 5.5 (39.8 to 48.7)	7 to 9 (62 to 80)	20	21
2376-1	20	<a href="#">VP230KH</a>	22	249.2x276.0x224.0	25.5 (56.2)	F	4.5 to 5.5 (39.8 to 48.7)	7 to 9 (62 to 80)	20	21
2376-2	20	<a href="#">VP230KH</a>	22	249.2x276.0x224.0	25.5 (56.2)	F	4.5 to 5.5 (39.8 to 48.7)	7 to 9 (62 to 80)	20	21
2376-3	20	<a href="#">VP230KH</a>	22	249.2x276.0x224.0	25.5 (56.2)	F	4.5 to 5.5 (39.8 to 48.7)	7 to 9 (62 to 80)	20	21
2376-4	20	<a href="#">VP230KH</a>	22	249.2x276.0x224.0	25.5 (56.2)	F	4.5 to 5.5 (39.8 to 48.7)	7 to 9 (62 to 80)	20	21
2376-7	20	<a href="#">VP230KH</a>	22	249.2x276.0x224.0	25.5 (56.2)	F	4.5 to 5.5 (39.8 to 48.7)	7 to 9 (62 to 80)	20	21
2376-8	20	<a href="#">VP230KH</a>	22	249.2x276.0x224.0	25.5 (56.2)	F	4.5 to 5.5 (39.8 to 48.7)	7 to 9 (62 to 80)	20	21
2376-9	20	<a href="#">VP230KH</a>	22	249.2x276.0x224.0	25.5 (56.2)	F	4.5 to 5.5 (39.8 to 48.7)	7 to 9 (62 to 80)	20	21
2376-10	20	<a href="#">VP230KH</a>	22	249.2x276.0x224.0	25.5 (56.2)	F	4.5 to 5.5 (39.8 to 48.7)	7 to 9 (62 to 80)	20	21
2378	20	<a href="#">VHP260KH-3</a>	26	249.2x276.0x224.0	26 (57.3)	F	4.5 to 5.5 (39.8 to 48.7)	7 to 9 (62 to 80)	20	21
2386-1	20	<a href="#">VP200KHB</a>	22	298.5x245.1x165.1 (11.75x9.65x6.50)	23.8 (52.5)	G	-	4 (40.0)	24 MS	33
2500	20	<a href="#">VO25KA</a>	25	497.0x129.0x182.0	27.2 (60)	H	4.5 to 5.5 (39.8 to 48.7)	7 to 9 (62 to 80)	20	60
2506-1	20	<a href="#">VP250KH</a>	23	363.0x172.0x222.0	28.0	D	4.5 to 5.5 (39.8 to 48.7)	7 to 9 (62 to 80)	20	21
2506-2	20	<a href="#">VP250KH</a>	23	363.0x172.0x222.0	28.0	D	4.5 to 5.5 (39.8 to 48.7)	7 to 9 (62 to 80)	20	21
2522	20	<a href="#">VO25KA-C</a>	25	549.0x129.0x221.5	31.3	F	4.5 to 5.5 (39.8 to 48.7)	7 to 9 (62 to 80)	20	60

Table 8002 - Battery specifications



Battery	Number of cells	Cell type	Rated capacity C <sub>10</sub> (Ah)	Dimension mm (in)	Weight kg (lbs)	Power connector type	Lower Nut torque value N.m (lbf.in)	Upper Nut torque value N.m (lbf.in)	Nozzle length mm	Electrolyte water volume cm <sup>3</sup>
2608	20	<a href="#">VHP260KH-3</a>	26	418.0x113.0x223.0	25.0	<a href="#">G</a>	4.5 to 5.5 (39.8 to 48.7)	7 to 9 (62 to 80)	20	21
2708	20	<a href="#">VHP270KH-3</a>	27	363.0x198.0x212.0	29.6	<a href="#">D</a>	4.5 to 5.5 (39.8 to 48.7)	12 to 14 (106 to 124)	20	25
2708-1	20	<a href="#">VHP270KH-3</a>	27	363.0x198.0x212.0	29.6	<a href="#">D</a>	4.5 to 5.5 (39.8 to 48.7)	12 to 14 (106 to 124)	20	25
2708-2	20	<a href="#">VHP270KH-3</a>	27	363.0x216x212.0	29	<a href="#">D</a>	4.5 to 5.5 (39.8 to 48.7)	12 to 14 (106 to 124)	20	25
2778	20	<a href="#">VHP270KH-3</a>	27	268.4x300.0x201.0 (10.5x11.8x7.9)	28.0	<a href="#">F</a>	4.5 to 5.5 (39.8 to 48.7)	12 to 14 (106 to 124)	20	25
2778-2	20	<a href="#">VHP270KH-3</a>	27	268.4x300.0x201.0 (10.5x11.8x7.9)	28.2 (62.2)	<a href="#">F</a>	4.5 to 5.5 (39.8 to 48.7)	12 to 14 (106 to 124)	20	25
2778-5	20	<a href="#">VHP270KH-3</a>	27	268.4x300.0x201.0 (10.5x11.8x7.9)	28.2	<a href="#">F</a>	4.5 to 5.5 (39.8 to 48.7)	12 to 14 (106 to 124)	20	25
2778-10	20	<a href="#">VHP270KH-3</a>	27	268.4x300.0x201.0 (10.5x11.8x7.9)	28.2	<a href="#">F</a>	4.5 to 5.5 (39.8 to 48.7)	12 to 14 (106 to 124)	20	25
2778-15	20	<a href="#">VHP270KH-3</a>	27	268.4x300.0x201.0 (10.5x11.8x7.9)	28.4	<a href="#">F</a>	4.5 to 5.5 (39.8 to 48.7)	12 to 14 (106 to 124)	20	25
2778-18	20	<a href="#">VHP270KH-3</a>	27	268.4x300.0x201.0 (10.5x11.8x7.9)	28.3	<a href="#">F</a>	4.5 to 5.5 (39.8 to 48.7)	12 to 14 (106 to 124)	20	25
2778-20	20	<a href="#">VHP270KH-3</a>	27	268.4x300.0x201.0 (10.5x11.8x7.9)	28.6	<a href="#">F</a>	4.5 to 5.5 (39.8 to 48.7)	12 to 14 (106 to 124)	20	25
4000A1	20	<a href="#">VO40KH</a>	40	420.0x216.0x275.0	36.5 (80.6)	<a href="#">D</a>	4.5 to 5.5 (39.8 to 48.7)	12 to 14 (106 to 124)	20	25
4000A1-1	20	<a href="#">VO40KH</a>	40	420.0x216.0x275.0	36.6 (80.6)	<a href="#">D</a>	4.5 to 5.5 (39.8 to 48.7)	12 to 14 (106 to 124)	20	25
4002	20	<a href="#">VO40KH-C</a>	40	420.0x216.0x270.0	36.3	<a href="#">D</a>	4.5 to 5.5 (39.8 to 48.7)	12 to 14 (106 to 124)	20	25
4006A	20	<a href="#">VP400KH*</a>	36	363.0x169.0x270.0	37.3	<a href="#">D</a>	4.5 to 5.5 (39.8 to 48.7)	12 to 14 (106 to 124)	20	25
4006A1-1	20	<a href="#">VP400KH*</a>	36	363.0x169.0x270.0	37.3	<a href="#">D</a>	4.5 to 5.5 (39.8 to 48.7)	12 to 14 (106 to 124)	20	25
4008-1	20	<a href="#">VHP430KH-3</a>	43	363.0x169.0x275.0	37.9	<a href="#">D</a>	4.5 to 5.5 (39.8 to 48.7)	12 to 14 (106 to 124)	20	25
4010CH	20	<a href="#">CVH400KA</a>	40	363.0x169.0x270.0 (14.29x6.65x10.63)	34.7 (76.3)	<a href="#">G</a>	4.5 to 5.5 (39.8 to 48.7)	12.4 to 13 (110 to 115)	20 MS	60
4015CH-11	20	<a href="#">CVH400KA</a>	40	254.0x248.0x262.0 (10.00x9.76x10.31)	36.0 (79.3)	<a href="#">G</a>	4.5 to 5.5 (39.8 to 48.7)	12.4 to 13 (110 to 115)	20 MS	60
4017CH-1	20	<a href="#">CVH400KA</a>	36	247.9x253.0x257.0 (9.76x9.96x10.11)	33.5 (73.7)	<a href="#">F</a>	4.5 to 5.5 (39.8 to 48.7)	12.4 to 13 (110 to 115)	20 MS	60
4017CH-3	20	<a href="#">CVH400KA</a>	36	247.9x253.0x257.0 (9.76x9.96x10.11)	36.4 (80.0)	<a href="#">F</a>	4.5 to 5.5 (39.8 to 48.7)	12.4 to 13 (110 to 115)	20 MS	60

Table 8002 - Battery specifications

## FITS AND CLEARANCES

Battery	Number of cells	Cell type	Rated capacity C <sub>10</sub> (Ah)	Dimension mm (in)	Weight kg (lbs)	Power connector type	Lower Nut torque value N.m (lbf.in)	Upper Nut torque value N.m (lbf.in)	Nozzle length mm	Electrolyte water volume cm <sup>3</sup>
4050A1-1	20	<a href="#">VO40KH</a>	40	268.4x300.0x262.0	35.5	E	4.5 to 5.5 (39.8 to 48.7)	12 to 14 (106 to 124)	20	25
4071	20	<a href="#">VO40KH</a>	40	268.4x300.0x228.6	36.8 (81)	F	4.5 to 5.5 (39.8 to 48.7)	12 to 14 (106 to 124)	20	25
4071-1	20	<a href="#">VO40KH</a>	40	268.4x300.0x262.0	36.0 (79.5)	F	4.5 to 5.5 (39.8 to 48.7)	12 to 14 (106 to 124)	20	25
4071-2	20	<a href="#">VO40KH</a>	40	268.4x300.0x262.0	36.0	F	4.5 to 5.5 (39.8 to 48.7)	12 to 14 (106 to 124)	20	25
4071-3	20	<a href="#">VO40KH</a>	40	268.4x300.0x262.0	36.2	F	4.5 to 5.5 (39.8 to 48.7)	12 to 14 (106 to 124)	20	25
4071-10	20	<a href="#">VO40KH</a>	40	268.4x300.0x262.0	36.7 (81)	F	4.5 to 5.5 (39.8 to 48.7)	12 to 14 (106 to 124)	20	25
4072	20	<a href="#">VO40KH-C</a>	40	268.4x300.0x262.0	36.9	F	4.5 to 5.5 (39.8 to 48.7)	12 to 14 (106 to 124)	20	25
4076	20	<a href="#">VP400KH*</a>	36	268.4x300.0x262.0	37.8 (83.3)	F	4.5 to 5.5 (39.8 to 48.7)	12 to 14 (106 to 124)	20	25
4076-1	20	<a href="#">VP400KH*</a>	36	268.4x300.0x262.0	37.8 (83.3)	F	4.5 to 5.5 (39.8 to 48.7)	12 to 14 (106 to 124)	20	25
4076-2	20	<a href="#">VP400KH*</a>	36	268.4x300.0x262.0	37.7	F	4.5 to 5.5 (39.8 to 48.7)	12 to 14 (106 to 124)	20	25
4076-3	20	<a href="#">VP400KH*</a>	36	268.4x300.0x262.0	37.7	F	4.5 to 5.5 (39.8 to 48.7)	12 to 14 (106 to 124)	20	25
4076-8	20	<a href="#">VP400KH*</a>	36	268.4x300.0x262.0	37.7	F	4.5 to 5.5 (39.8 to 48.7)	12 to 14 (106 to 124)	20	25
4076-9	20	<a href="#">VP400KH*</a>	36	268.4x300.0x262.0	37.8 (83.3)	F	4.5 to 5.5 (39.8 to 48.7)	12 to 14 (106 to 124)	20	25
4076-11	20	<a href="#">VP400KH*</a>	40	268.4x300.0x262.0	37.8	F	4.5 to 5.5 (39.8 to 48.7)	12 to 14 (106 to 124)	20	25
4076-12	20	<a href="#">VP400KH*</a>	40	268.4x300.0x262.0	37.8	F	4.5 to 5.5 (39.8 to 48.7)	12 to 14 (106 to 124)	20	25
4076-13	20	<a href="#">VP400KH*</a>	40	268.4x300.0x262.0	37.8	F	4.5 to 5.5 (39.8 to 48.7)	12 to 14 (106 to 124)	20	25
4076-15	20	<a href="#">VP400KH*</a>	36	268.4x300.0x262.0	37.7	F	4.5 to 5.5 (39.8 to 48.7)	12 to 14 (106 to 124)	20	25
4076-16	20	<a href="#">VP400KH*</a>	36	268.4x300.0x262.0	37.8	F	4.5 to 5.5 (39.8 to 48.7)	12 to 14 (106 to 124)	20	25
4076-17	20	<a href="#">VP400KH*</a>	36	268.4x300.0x262.0	37.8	F	4.5 to 5.5 (39.8 to 48.7)	12 to 14 (106 to 124)	20	25
4076-18	20	<a href="#">VP400KH-SQ</a>	36	268.4x300.0x262.0	37.8	F	4.5 to 5.5 (39.8 to 48.7)	12 to 14 (106 to 124)	38	25
4076-19	20	<a href="#">VP400KH*</a>	36	268.4x300.0x262.0	37.7	F	4.5 to 5.5 (39.8 to 48.7)	12 to 14 (106 to 124)	20	25

Table 8002 - Battery specifications



Battery	Number of cells	Cell type	Rated capacity C <sub>10</sub> A (Ah)	Dimension mm (in)	Weight kg (lbs)	Power connector type	Lower Nut torque value N.m (lbf.in)	Upper Nut torque value N.m (lbf.in)	Nozzle length mm	Electrolyte water volume cm <sup>3</sup>
4076-21	20	<a href="#">VP400KH*</a>	36	268.4x300.0x262.0	38 (83.7)	F	4.5 to 5.5 (39.8 to 48.7)	12 to 14 (106 to 124)	20	25
4077	19	<a href="#">VP400KH-MS</a>	34	268.4x300.0x262.0	36.3 (80)	G	-	4 to 5 (35 to 44)	20	25
4078	20	<a href="#">VHP430KH-3</a>	43	268.4x300.0x262.0	38.5	F	4.5 to 5.5 (39.8 to 48.7)	12 to 14 (106 to 124)	20	25
4078-1	20	<a href="#">VHP430KH-3</a>	43	268.4x300.0x262.0	38.5	F	4.5 to 5.5 (39.8 to 48.7)	12 to 14 (106 to 124)	20	25
4078-5	20	<a href="#">VHP430KH-3</a>	43	268.4x300.0x262.0	38.4	F	4.5 to 5.5 (39.8 to 48.7)	12 to 14 (106 to 124)	20	25
4078-6	20	<a href="#">VHP430KH-3</a>	43	268.4x300.0x262.0	38.4	F	4.5 to 5.5 (39.8 to 48.7)	12 to 14 (106 to 124)	20	25
4078-9	20	<a href="#">VHP430KH-3</a>	43	268.4x300.0x262.0	38.4	F	4.5 to 5.5 (39.8 to 48.7)	12 to 14 (106 to 124)	20	25
4078-10	20	<a href="#">VHP430KH-3</a>	43	268.4x300.0x262.0	38.4	F	4.5 to 5.5 (39.8 to 48.7)	12 to 14 (106 to 124)	20	25
4078-11	20	<a href="#">VHP430KH-3</a>	43	268.4x300.0x262.0	38.6 (85.1)	F	4.5 to 5.5 (39.8 to 48.7)	12 to 14 (106 to 124)	20	25
4078-13	20	<a href="#">VHP430KH-3</a>	43	268.4x300.0x262.0	38.5	F	4.5 to 5.5 (39.8 to 48.7)	12 to 14 (106 to 124)	20	25
4078-15	20	<a href="#">VHP430KH-3</a>	43	268.4x300.0x262.0	38.5	F	4.5 to 5.5 (39.8 to 48.7)	12 to 14 (106 to 124)	20	25
4078-16	20	<a href="#">VHP430KH-3</a>	43	268.4x300.0x262.0	38.6	F	4.5 to 5.5 (39.8 to 48.7)	12 to 14 (106 to 124)	20	25
4078-18	20	<a href="#">VHP430KH-3</a>	43	268.4x300.0x262.0	38.4 (84.7)	F	4.5 to 5.5 (39.8 to 48.7)	12 to 14 (106 to 124)	20	25
4078-19	20	<a href="#">VHP430KH-3</a>	43	268.4x300.0x262.0	38.4 (84.7)	F	4.5 to 5.5 (39.8 to 48.7)	12 to 14 (106 to 124)	20	25
4078-21	20	<a href="#">VHP430KH-3</a>	43	268.4x300.0x262.0	38.4	F	4.5 to 5.5 (39.8 to 48.7)	12 to 14 (106 to 124)	20	25
4078-25	20	<a href="#">VHP430KH-3</a>	43	268.4x300.0x262.0	38.4	F	4.5 to 5.5 (39.8 to 48.7)	12 to 14 (106 to 124)	20	25
4079	20	<a href="#">VHP370KA-3</a>	37	268.4x300.0x262.0	38.3	F	4.5 to 5.5 (39.8 to 48.7)	12 to 14 (106 to 124)	20	60
4079-1	20	<a href="#">VHP370KA-3</a>	37	268.4x300.0x262.0	38.9	F	4.5 to 5.5 (39.8 to 48.7)	12 to 14 (106 to 124)	20	60
4079-2	20	<a href="#">VHP370KA-3</a>	37	268.4x300.0x262.0	38.9	F	4.5 to 5.5 (39.8 to 48.7)	12 to 14 (106 to 124)	20	60
4079-4	20	<a href="#">VHP370KA-3</a>	37	268.4x300.0x262.0	38.9	F	4.5 to 5.5 (39.8 to 48.7)	12 to 14 (106 to 124)	20	60
4079-6	20	<a href="#">VHP370KA-3</a>	37	268.4x300.0x262.0	38.9	F	4.5 to 5.5 (39.8 to 48.7)	12 to 14 (106 to 124)	20	60

Table 8002 - Battery specifications



## FITS AND CLEARANCES

Battery	Number of cells	Cell type	Rated capacity C <sub>10</sub> (Ah)	Dimension mm (in)	Weight kg (lbs)	Power connector type	Lower Nut torque value N.m (lbf.in)	Upper Nut torque value N.m (lbf.in)	Nozzle length mm	Electrolyte water volume cm <sup>3</sup>
4079-9	20	<a href="#">VHP370KA-3</a>	37	268.4x300.0x262.0	38.9	F	4.5 to 5.5 (39.8 to 48.7)	12 to 14 (106 to 124)	20	60
4079-10	20	<a href="#">VHP370KA-3</a>	37	268.4x300.0x262.0	38.9	F	4.5 to 5.5 (39.8 to 48.7)	12 to 14 (106 to 124)	20	60
4080	20	<a href="#">VO40KH</a>	40	252.6x246.6x262.2	37.2	D	4.5 to 5.5 (39.8 to 48.7)	12 to 14 (106 to 124)	20	25
4317CH1	20	<a href="#">CVH430KA</a>	43	249.0x254.0x256.5 (9.8x 10.0x10.1)	37.7 (83)	F	4.5 to 5.5 (39.8 to 48.7)	7 to 9 (62 to 80)	20*	70
4410CH1	20	<a href="#">CVH441KH</a>	44	420.0x216.0x270	36.4 (80.3)	F	4.5 to 5.5 (39.8 to 48.7)	12 to 14 (106 to 124)	38	10
5035CH4	20	<a href="#">CVH500KA</a>	50	298.0x299.0x270.0 (11.7x11.8x10.6)	42.5 (93.7)	F	4.5 to 5.5 (39.8 to 48.7)	12 to 14 (106 to 124)	20	60
6206	20	<a href="#">VP65K</a>	6	372.5x124.5x161.5	9.2 (20.2)	I	4.5 to 5.5 (39.8 to 48.7)	7 to 9 (62 to 80)	17	8
8050	10	<a href="#">VO80KH</a>	80	358.2x184.0x315.0 14.10x7.24x12.40	37.0	J	4.5 to 5.5 (39.8 to 48.7)	12 to 14 (106 to 124)	15	60
12150	20	<a href="#">VO23KH</a>	23	255.6x199.6x225.6	23.4	G	4.5 to 5.5 (39.8 to 48.7)	7 to 9 (62 to 80)	20	21
12277	19	<a href="#">VP120KHB</a>	15	193.5x197.0x198.4 (7.62x7.75x7.81)	15.4x34	G	-	2.5 to 3.5 (22 to 31)	24 MS	15
12277-1	19	<a href="#">VP120KHB</a>	15	193.5x197.0x198.4 (7.62x7.75x7.81)	15.4x34	G	-	2.5 to 3.5 (22 to 31)	24 MS	15
12277-2	19	<a href="#">VP120KHB</a>	15	193.5x197.0x198.4 (7.62x7.75x7.81)	15.4x34	G	-	2.5 to 3.5 (22 to 31)	24 MS	15
16100	20	<a href="#">VO16KH</a>	16	337.0x129.0x182.0	18.7	B	4.5 to 5.5 (39.8 to 48.7)	7 to 9 (62 to 80)	20	20
16106-1	20	<a href="#">VP160KM-SQ</a>	16	356.5x132.0x204.5	17.1 (37.7)		4.5 to 5.5 (39.8 to 48.7)	7 to 9 (62 to 80)	33	8
16108-1	20	<a href="#">VHP170KH-3-SQ</a>	17	356.0x125.0x204.5	17.7	I	4.5 to 5.5 (39.8 to 48.7)	7 to 9 (62 to 80)	33	8
16156	20	<a href="#">VP160KH</a>	15	271.6x163.1x185.5	18.1	F	4.5 to 5.5 (39.8 to 48.7)	7 to 9 (62 to 80)	20	20
16156-1	20	<a href="#">VP160KH</a>	15	271.6x163.1x185.5	18.1	F	4.5 to 5.5 (39.8 to 48.7)	7 to 9 (62 to 80)	20	20
16158	20	<a href="#">VHP170KH-3</a>	17	273.8x165.1x187.0	18.7	I	4.5 to 5.5 (39.8 to 48.7)	7 to 9 (62 to 80)	20	20
16256	20	<a href="#">VP160KH</a>	15	273.0x164.6x187.2	18.0	J	4.5 to 5.5 (39.8 to 48.7)	7 to 9 (62 to 80)	20	20
16256-3	20	<a href="#">VP160KH</a>	17	273.0x164.6x187.2	18.0	J	4.5 to 5.5 (39.8 to 48.7)	7 to 9 (62 to 80)	20	20
16258	20	<a href="#">VHP170KH-3</a>	17	271.6x215.0x181.0	18.3	I	4.5 to 5.5 (39.8 to 48.7)	7 to 9 (62 to 80)	20	20

Table 8002 - Battery specifications

FITS AND CLEARANCES

Battery	Number of cells	Cell type	Rated capacity C <sub>10</sub> (Ah)	Dimension mm (in)	Weight kg (lbs)	Power connector type	Lower Nut torque value N.m (lbf.in)	Upper Nut torque value N.m (lbf.in)	Nozzle length mm	Electrolyte water volume cm <sup>3</sup>
16356	20	<a href="#">VP160KH</a>	15	273.0x164.6x187.2	18.0	<a href="#">G</a>	4.5 to 5.5 (39.8 to 48.7)	7 to 9 (62 to 80)	20	20
16556	20	<a href="#">VP160KM</a>	16	267.0x179.5x183.5	19.1	<a href="#">G</a>	4.5 to 5.5 (39.8 to 48.7)	7 to 9 (62 to 80)	20	20
20126	20	<a href="#">VP200KHB</a>	22	298.5x245.1x165.1 11.75x9.65x6.50	23.8	<a href="#">G</a>	-	4 (40.0)	24	33
20126-2	20	<a href="#">VP200KHB</a>	22	298.5x245.1x165.1 11.75x9.65x6.50	23.5	<a href="#">G</a>	-	4 (40.0)	24	33
20126-3	20	<a href="#">VP200KHB</a>	22	298.5x245.1x165.1 11.75x9.65x6.5	23.5	<a href="#">G</a>	-	4 (40.0)	24	33
23171-4	20	<a href="#">VO23KH-SQ</a>	23	254.0x198.0x224.0	24.5	<a href="#">G</a>	4.5 to 5.5 (39.8 to 48.7)	7 to 9 (62 to 80)	20	21
23175	19	<a href="#">VP230KH</a>	22	249.2x276x224	23.7 (52.3)	<a href="#">F</a>	4.5 to 5.5 (39.8 to 48.7)	7 to 9 (62 to 80)	20	21
23176	20	<a href="#">VP230KH</a>	22	249.2x276x224	25 (55.1)	<a href="#">F</a>	4.5 to 5.5 (39.8 to 48.7)	7 to 9 (62 to 80)	20	21
23376	20	<a href="#">VP230KH</a>	22	254.0x198.0x224.0	25.5	<a href="#">G</a>	4.5 to 5.5 (39.8 to 48.7)	7 to 9 (62 to 80)	20	21
23378	20	<a href="#">VHP260KH-3</a>	26	254.0x198.0x224.0	25.8	<a href="#">G</a>	4.5 to 5.5 (39.8 to 48.7)	7 to 9 (62 to 80)	20	21
23476	20	<a href="#">VP230KH</a>	22	254.0x198.0x224.0	25.5	<a href="#">G</a>	4.5 to 5.5 (39.8 to 48.7)	7 to 9 (62 to 80)	20	21
23478	20	<a href="#">VHP260KH-3</a>	26	254.0x198.0x224.0	26.4	<a href="#">G</a>	4.5 to 5.5 (39.8 to 48.7)	7 to 9 (62 to 80)	20	21
23491	20	<a href="#">VO23KH</a>	23	276.0x250.0x224.0	24.7 (54.4)	<a href="#">G</a>	4.5 to 5.5 (39.8 to 48.7)	7 to 9 (62 to 80)	20	21
23491-3	20	<a href="#">VO23KH</a>	23	276.0x250.0x224.0	24.7 (54.4)	<a href="#">G</a>	4.5 to 5.5 (39.8 to 48.7)	7 to 9 (62 to 80)	20	21
23491-4	20	<a href="#">VO23KH</a>	23	276.0x250.0x224.0	23.6	<a href="#">G</a>	4.5 to 5.5 (39.8 to 48.7)	7 to 9 (62 to 80)	20	21
23498-1	20	<a href="#">VHP260KH-3</a>	26	276.0x250.0x224.0	25.6 (56.4)	<a href="#">G</a>	4.5 to 5.5 (39.8 to 48.7)	7 to 9 (62 to 80)	20	21
23576	20	<a href="#">VP230KH</a>	22	254.0x198.0x224.0	25.5	<a href="#">G</a>	4.5 to 5.5 (39.8 to 48.7)	7 to 9 (62 to 80)	20	21
23576-1	20	<a href="#">VP230KH</a>	22	252.5x195.3x222.3	25.0	<a href="#">G</a>	4.5 to 5.5 (39.8 to 48.7)	7 to 9 (62 to 80)	20	21
23576-2	20	<a href="#">VP230KH</a>	22	252.5x195.3x222.3	25.0	<a href="#">G</a>	4.5 to 5.5 (39.8 to 48.7)	7 to 9 (62 to 80)	20	21
23676	20	<a href="#">VP230KH</a>	24	457.2x114.6x224.0	25.9	<a href="#">G</a>	4.3 to 5.2 (38 to 46)	9 to 9.9 (80 to 88)	20	21
23676-1	20	<a href="#">VP230KH</a>	24	457.2x114.6x224.0	25.9	<a href="#">G</a>	4.3 to 5.2 (38 to 46)	9 to 9.9 (80 to 88)	20	21

Table 8002 - Battery specifications

FITS AND CLEARANCES

Battery	Number of cells	Cell type	Rated capacity C <sub>10</sub> (Ah)	Dimension mm (in)	Weight kg (lbs)	Power connector type	Lower Nut torque value N.m (lbf.in)	Upper Nut torque value N.m (lbf.in)	Nozzle length mm	Electrolyte water volume cm <sup>3</sup>
23676-2	20	<a href="#">VP230KH</a>	24	457.2x114.6x224.0	25.9	<a href="#">G</a>	4.3 to 5.2 (38 to 46)	9 to 9.9 (80 to 88)	20	21
23678-1	20	<a href="#">VHP260KH-3-SQ</a>	26	254.0x198.0x224.0	26.1	<a href="#">G</a>	4.5 to 5.5 (39.8 to 48.7)	7 to 9 (62 to 80)	33	8
23678-2	20	<a href="#">VHP260KH-3-SQ</a>	26	254.0x198.0x224.0	25.5	<a href="#">G</a>	4.5 to 5.5 (39.8 to 48.7)	7 to 9 (62 to 80)	33	8
23678-3	20	<a href="#">VHP260KH-3-SQ</a>	26	254.0x198.0x224.0	26.7	<a href="#">G</a>	4.5 to 5.5 (39.8 to 48.7)	7 to 9 (62 to 80)	33	8
25106	20	<a href="#">VP250KH</a>	23	363.0x172.0x222.0	28.0	<a href="#">G</a>	4.5 to 5.5 (39.8 to 48.7)	7 to 9 (62 to 80)	20	21
25106-2	20	<a href="#">VP250KH</a>	23	363.0x172.0x222.0	28.0	<a href="#">G</a>	4.5 to 5.5 (39.8 to 48.7)	7 to 9 (62 to 80)	20	21
26108-3	20	<a href="#">VHP260KH-3</a>	26	301.5x174.0x230.0	24.5	<a href="#">G</a>	4.5 to 5.5 (39.8 to 48.7)	7 to 9 (62 to 80)	20	21
26108-4	20	<a href="#">VHP260KH-3</a>	26	301.5x174.0x230.0	24.5	<a href="#">G</a>	4.5 to 5.5 (39.8 to 48.7)	7 to 9 (62 to 80)	20	21
26108-5	20	<a href="#">VHP260KH-3</a>	26	301.5x174.0x230.0	24.5	<a href="#">G</a>	4.5 to 5.5 (39.8 to 48.7)	7 to 9 (62 to 80)	20	21
26108-7	20	<a href="#">VHP260KH-3</a>	26	301.5x174.0x230.0	24.5 (54)	<a href="#">G</a>	4.5 to 5.5 (39.8 to 48.7)	7 to 9 (62 to 80)	20	21
26308-1	20	<a href="#">VHP260KH-3</a>	26	281.0x166.0x229.0	25.4	<a href="#">G</a>	4.5 to 5.5 (39.8 to 48.7)	7 to 9 (62 to 80)	20	21
26308-5	20	<a href="#">VHP260KH-3</a>	26	281.0x166.0x229.0	25.4	<a href="#">G</a>	4.5 to 5.5 (39.8 to 48.7)	7 to 9 (62 to 80)	20	21
26408-1	20	<a href="#">VHP260KH-3</a>	26	281.0x166.0x229.0	25.4	<a href="#">G</a>	4.5 to 5.5 (39.8 to 48.7)	7 to 9 (62 to 80)	20	21
26508	20	<a href="#">VHP260KH-3</a>	26	466.0x170.0x245.2	26.8	<a href="#">J</a>	4.5 to 5.5 (39.8 to 48.7)	7 to 9 (62 to 80)	20	21
26608	20	<a href="#">VHP260KH-3</a>	26	466.0x170.0x245.2	26.8	<a href="#">J</a>	4.5 to 5.5 (39.8 to 48.7)	7 to 9 (62 to 80)	20	21
26608-1	20	<a href="#">VHP260KH-3</a>	26	476.6x188x245.2	26.9 (59.3)	<a href="#">J</a>	4.5 to 5.5 (39.8 to 48.7)	7 to 9 (62 to 80)	20	21
26708	20	<a href="#">VHP260KH-3</a>	26	464.0x170.0x245.2	26.9	<a href="#">J</a>	4.5 to 5.5 (39.8 to 48.7)	7 to 9 (62 to 80)	20	21
26808		<a href="#">VHP260KH-3</a>	26	482.0x170.0x236.8	26.9 (58.4)	<a href="#">J</a>	4.5 to 5.5 (39.8 to 48.7)	7 to 9 (62 to 80)	20	21
27168-1	20	<a href="#">VHP270KH-3-SQ</a>	27	360.5x170.0x202.0	28.3	<a href="#">G</a>	4.5 to 5.5 (39.8 to 48.7)	12 to 14 (106 to 124)	38	10
27278	20	<a href="#">VHP270KH-3</a>	27	254.0x248.0x201.0	28.3	<a href="#">G</a>	4.5 to 5.5 (39.8 to 48.7)	12 to 14 (106 to 124)	20	25
27278-2	20	<a href="#">VHP270KH-3-SQ</a>	27	254.0x248.0x201.0	28.3	<a href="#">G</a>	4.5 to 5.5 (39.8 to 48.7)	12 to 14 (106 to 124)	38	10

Table 8002 - Battery specifications

## FITS AND CLEARANCES

Battery	Number of cells	Cell type	Rated capacity C <sub>10</sub> (Ah)	Dimension mm (in)	Weight kg (lbs)	Power connector type	Lower Nut torque value N.m (lbf.in)	Upper Nut torque value N.m (lbf.in)	Nozzle length mm	Electrolyte water volume cm <sup>3</sup>
27478	20	<a href="#">VHP270KH-3</a>	27	268.4x300.0x216.0	28.3	F	4.5 to 5.5 (39.8 to 48.7)	12 to 14 (106 to 124)	20	25
27578-2	20	<a href="#">VHP270KH-3</a>	27	254.0x248.0x201.0	28.3	G	4.5 to 5.5 (39.8 to 48.7)	12 to 14 (106 to 124)	20	25
40042	10	<a href="#">VOEC40KH</a>	40	223.0x184.0x248.0	21.5	G	4.5 to 5.5 (39.8 to 48.7)	12 to 14 (106 to 124)	20	25
40100A	20	<a href="#">VO40KH</a>	40	363.0x169.0x275.0	35.5	G	4.5 to 5.5 (39.8 to 48.7)	12 to 14 (106 to 124)	20	25
40100-1	20	<a href="#">VO40KH</a>	40	363.0x169.0x275.0	35.5	G	4.5 to 5.5 (39.8 to 48.7)	12 to 14 (106 to 124)	20	25
40142	11	<a href="#">VOEC40KH</a>	40	223.0x184.0x248.0	21.5	G	4.5 to 5.5 (39.8 to 48.7)	12 to 14 (106 to 124)	20	25
40152	11	<a href="#">VO40KH</a>	40	233.7x231.2x290.6	11 (24.2)	G	4.5 to 5.5 (39.8 to 48.7)	12 to 14 (106 to 124)	20	25
40153	11	<a href="#">VP400KH*</a>	36	224.0x181.6x253.6	21.9	G	4.5 to 5.5 (39.8 to 48.7)	12 to 14 (106 to 124)	20	25
40176-10	20	<a href="#">VP400KH*</a>	36	254.0x248.0x262.0	37.4	G	4.5 to 5.5 (39.8 to 48.7)	12 to 14 (106 to 124)	20	25
40178	20	<a href="#">VHP430KH-3</a>	43	340.0x248.0x262.0	41.0	G	4.5 to 5.5 (39.8 to 48.7)	12 to 14 (106 to 124)	20	25
40178-7	20	<a href="#">VHP430KH-3</a>	43	340.0x248.0x262.0	41.0	G	4.5 to 5.5 (39.8 to 48.7)	12 to 14 (106 to 124)	20	25
40178-21	20	<a href="#">VHP430KH-3</a>	43	254.0x248.0x262.0	38.4	G	4.5 to 5.5 (39.8 to 48.7)	12 to 14 (106 to 124)	20	25
40179-7	20	<a href="#">VHP370KA-3</a>	37	268.4x304.8x264.0	38.5 (84.9)	G	4.5 to 5.5 (39.8 to 48.7)	12 to 14 (106 to 124)	20	60
40200	20	<a href="#">VO40KH</a>	40	420.0x169.0x270.0	35.9	D	4.5 to 5.5 (39.8 to 48.7)	12 to 14 (106 to 124)	20	25
40200-1	20	<a href="#">VO40KH</a>	40	420.0x169.0x270.0	36.6	D	4.5 to 5.5 (39.8 to 48.7)	12 to 14 (106 to 124)	20	25
40206-2	20	<a href="#">VP400KH*</a>	36	420.0x169.0x270.0	37.3	D	4.5 to 5.5 (39.8 to 48.7)	12 to 14 (106 to 124)	20	25
40208	20	<a href="#">VHP430KH-3</a>	43	420.0x216.0x270.0	38.0	D	4.5 to 5.5 (39.8 to 48.7)	12 to 14 (106 to 124)	20	25
40208-1	20	<a href="#">VHP430KH-3</a>	43	420.0x216.0x270.0	38.2 (84.1)	D	4.5 to 5.5 (39.8 to 48.7)	12 to 14 (106 to 124)	20	25
40208-2	20	<a href="#">VHP430KH-3</a>	43	420.0x216.0x270.0	38.2 (84.1)	D	4.5 to 5.5 (39.8 to 48.7)	12 to 14 (106 to 124)	20	25
40208-4	20	<a href="#">VHP430KH-3</a>	43	420.0x216.0x270.0	38.2 (84.1)	D	4.5 to 5.5 (39.8 to 48.7)	12 to 14 (106 to 124)	20	25
40208-5	20	<a href="#">VHP430KH-3</a>	43	420.0x216.0x270.0	38.2 (84.1)	D	4.5 to 5.5 (39.8 to 48.7)	12 to 14 (106 to 124)	20	25

Table 8002 - Battery specifications

## FITS AND CLEARANCES

Battery	Number of cells	Cell type	Rated capacity C <sub>10</sub> (Ah)	Dimension mm (in)	Weight kg (lbs)	Power connector type	Lower Nut torque value N.m (lbf.in)	Upper Nut torque value N.m (lbf.in)	Nozzle length mm	Electrolyte water volume cm <sup>3</sup>
40208-6	20	<a href="#">VHP430KH-3</a>	43	420.0x216.0x270.0	38.3	<a href="#">D</a>	4.5 to 5.5 (39.8 to 48.7)	12 to 14 (106 to 124)	20	25
40208-7	20	<a href="#">VHP430KH-3SQ</a>	43	420.0x216.0x270.0	38.3	<a href="#">D</a>	4.5 to 5.5 (39.8 to 48.7)	12 to 14 (106 to 124)	38	10
40209-2	20	<a href="#">VHP370KA-3</a>	37	412.0x209.0x230.0	37.0	<a href="#">D</a>	4.5 to 5.5 (39.8 to 48.7)	12 to 14 (106 to 124)	20	60
40253	11	<a href="#">VP340KA</a>	34	224.0x181.6x254.5	21.0	<a href="#">G</a>	4.5 to 5.5 (39.8 to 48.7)	12 to 14 (106 to 124)	20	55
40278-2	20	<a href="#">VHP430KH-3SQ</a>	43	254.0x248.0x262.0	38.5	<a href="#">G</a>	4.5 to 5.5 (39.8 to 48.7)	12 to 14 (106 to 124)	38	10
40278-14	20	<a href="#">VHP430KH-3</a>	43	300.0x268.4x262.0	38.4 (84.7)	<a href="#">D</a>	4.5 to 5.5 (39.8 to 48.7)	12 to 14 (106 to 124)	20	25
40300	20	<a href="#">VO40KH-3</a>	40	363.0x169.0x270.0	33.0	<a href="#">J</a>	4.5 to 5.5 (39.8 to 48.7)	12 to 14 (106 to 124)	20	25
40306	20	<a href="#">VP400KH-SQ</a>	36	363.0x169.0x270.0	37.0	<a href="#">D</a>	4.5 to 5.5 (39.8 to 48.7)	12 to 14 (106 to 124)	38	25
40342	10	<a href="#">VOEC40KH</a>	40	219.0x166.0x250.0	18.5	<a href="#">G</a>	4.5 to 5.5 (39.8 to 48.7)	12 to 14 (106 to 124)	20	25
40353	11	<a href="#">VP380KH</a>	42	224.0x181.6x254.5	21.0	<a href="#">G</a>	4.5 to 5.5 (39.8 to 48.7)	12 to 14 (106 to 124)	20	25
40371	20	<a href="#">VOEC40KH</a>	40	253.0x247.5x249.0	36.0	<a href="#">G</a>	4.5 to 5.5 (39.8 to 48.7)	12 to 14 (106 to 124)	20	25
40376	20	<a href="#">VP400KH*</a>	36	303.0x247.4x262.0	37.7	<a href="#">G</a>	4.5 to 5.5 (39.8 to 48.7)	12 to 14 (106 to 124)	20	25
40378	20	<a href="#">VHP430KH-3</a>	43	277.6x213.9x256.0	36.3	<a href="#">G</a>	4.5 to 5.5 (39.8 to 48.7)	12 to 14 (106 to 124)	20	25
40379	20	<a href="#">VHP370KH-3-SQ</a>	37	254.0x248.0x262.0	38.4	<a href="#">G</a>	4.5 to 5.5 (39.8 to 48.7)	12 to 14 (106 to 124)	38	25
40408	20	<a href="#">VHP430KH-3</a>	43	363.0x169.0x270.0	37.9	<a href="#">D</a>	4.5 to 5.5 (39.8 to 48.7)	12 to 14 (106 to 124)	20	25
40478-1	20	<a href="#">VHP430KH-3</a>	43	254.0x248.3x249.0	36.6	<a href="#">G</a>	4.5 to 5.5 (39.8 to 48.7)	12 to 14 (106 to 124)	20	25
40508-1	20	<a href="#">VHP430KH-3SQ</a>	43	398.5x169.0x265.0	38.3	<a href="#">G</a>	4.5 to 5.5 (39.8 to 48.7)	12 to 14 (106 to 124)	38*	10
40576	20	<a href="#">VP400KH-AC</a>	36	254.0x248.0x262.0	36.8	<a href="#">G</a>	4.5 to 5.5 (39.8 to 48.7)	12 to 14 (106 to 124)	24 MS	25
40576-3	20	<a href="#">VP400KH-AC</a>	36	254.0x248.0x262.0	36.8	<a href="#">G</a>	4.5 to 5.5 (39.8 to 48.7)	12 to 14 (106 to 124)	24 MS	25
40576-14	20	<a href="#">VP400KH-AC</a>	36	254.0x248.0x262.0	36.8	<a href="#">G</a>	4.5 to 5.5 (39.8 to 48.7)	12 to 14 (106 to 124)	24 MS	25
40578-1	20	<a href="#">VHP430KH-3</a>	43	254.0x248.0x248.8	37.4	<a href="#">G</a>	4.5 to 5.5 (39.8 to 48.7)	12 to 14 (106 to 124)	20	25

Table 8002 - Battery specifications

## FITS AND CLEARANCES

Battery	Number of cells	Cell type	Rated capacity C <sub>10</sub> (Ah)	Dimension mm (in)	Weight kg (lbs)	Power connector type	Lower Nut torque value N.m (lbf.in)	Upper Nut torque value N.m (lbf.in)	Nozzle length mm	Electrolyte water volume cm <sup>3</sup>
40676	20	<a href="#">VP400KH-AC</a>	36	254.0x247.7x266.7	36.3	<a href="#">G</a>	4.5 to 5.5 (39.8 to 48.7)	12 to 14 (106 to 124)	24 MS	25
40678	20	<a href="#">VHP430KH-3</a>	43	254.0x248.0x262.0	38.6	<a href="#">G</a>	4.5 to 5.5 (39.8 to 48.7)	12 to 14 (106 to 124)	20	25
40678-1	20	<a href="#">VHP430KH-3</a>	45	254.0x248.0x262.0	38.6	<a href="#">G</a>	4.5 to 5.5 (39.8 to 48.7)	12 to 14 (106 to 124)	20	25
40678-4	20	<a href="#">VHP450KH-1</a>	45	254.0x248.0x262.0	38.4	<a href="#">G</a>	4.5 to 5.5 (39.8 to 48.7)	12 to 14 (106 to 124)	20	25
40776	20	<a href="#">VP400KH-AC</a>	40	254.0x248.4x262.0	37.6	<a href="#">G</a>	4.5 to 5.5 (39.8 to 48.7)	12 to 14 (106 to 124)	24 MS	25
40778-11	20	<a href="#">VHP430KH-3</a>	43	254.0x248.0x262.0 (10.00x9.76x10.31)	38.6	<a href="#">G</a>	4.5 to 5.5 (39.8 to 48.7)	12 to 14 (106 to 124)	20	25
40876	20	<a href="#">VP400KH*</a>	36	252.0x246.0x260.0	37.0	<a href="#">G</a>	4.5 to 5.5 (39.8 to 48.7)	12 to 14 (106 to 124)	20	25
40876-10	20	<a href="#">VP400KH*</a>	36	252.0x246.0x260.0	37.0	<a href="#">G</a>	4.5 to 5.5 (39.8 to 48.7)	12 to 14 (106 to 124)	20	25
401076	20	<a href="#">VP400KH-AC</a>	40	254.0x247.5x264.8	36.3	<a href="#">G</a>	4.5 to 5.5 (39.8 to 48.7)	12 to 14 (106 to 124)	24 MS	25
401176-10	20	<a href="#">VP400KH*</a>	40	254.0x247.5x260.0	37.0	<a href="#">G</a>	4.5 to 5.5 (39.8 to 48.7)	12 to 14 (106 to 124)	20	25
A185CH	20	<a href="#">CVH180KH-SQ</a>	18	253.0x197.0x162.0 (9.9x7.8x6.4)	18.3 (40.4)	<a href="#">I</a>	4.5 to 5.5 (39.8 to 48.7)	7 to 9 (62 to 80)	26	9
A275CH1	20	<a href="#">CVH271KH-SQ</a>	27	254.0x265.5x230.0	23.7 (52.3)	<a href="#">F</a>	4.5 to 5.5 (39.8 to 48.7)	7 to 9 (62 to 80)	33	8
A407CH-3	20	<a href="#">CVH400KH-SQ</a>	40	300.0x269.0x280.0(1 1.8x10.6x11.0)	34.3 (75.7)	<a href="#">D</a>	4.5 to 5.5 (39.8 to 48.7)	12.4 to 13 (110 to 115)	38 MS	25
A408CH	20	<a href="#">CVH400KH-SQ</a>	40	252.6x246.6x266.6 (9.94x9.71x10.50)	35.1 (77.4)	<a href="#">D</a>	4.5 to 5.5 (39.8 to 48.7)	12.4 to 13 (110 to 115)	38 MS	25
A2609-1	20	<a href="#">VHP260KH-3-SQ</a>	26	-	21.5 (47.4)	<a href="#">G</a>	4.5 to 5.5 (39.8 to 48.7)	7 to 9 (62 to 80)	33	8
A26908	20	<a href="#">VHP260KH-3-SQ</a>	26	-	27.7 (61.1)	<a href="#">G</a>	4.5 to 5.5 (39.8 to 48.7)	7 to 9 (62 to 80)	33	8
A4076-21	20	<a href="#">VP400KH-SQ</a>	36	268.4x300.0x262.0 (10.56x11.81x10.31)	37.4 82.5	<a href="#">F</a>	4.5 to 5.5 (39.8 to 48.7)	12 to 14 (106 to 124)	38	25
A4078-12	20	<a href="#">VHP430KH-3SQ</a>	43	268.4x300x262	38.5 (84.8)	<a href="#">F</a>	4.5 to 5.5 (39.8 to 48.7)	12 to 14 (106 to 124)	38	10
A40209	20	<a href="#">VHP370KH-3-SQ</a>	37	363.0x169.0x270.0	37.9	<a href="#">D</a>	4.5 to 5.5 (39.8 to 48.7)	12 to 14 (106 to 124)	38	25
A40209-1	20	<a href="#">VHP370KH-3-SQ</a>	37	363.0x169.0x270.0	37.9	<a href="#">D</a>	4.5 to 5.5 (39.8 to 48.7)	12 to 14 (106 to 124)	38	25
B153CH1	20	<a href="#">CVH150KH</a>	15	364.0x138.5x196.0	15.3 (33.7)	<a href="#">J</a>	4.5 to 5.5 (39.8 to 48.7)	7 to 9 (62 to 80)	20	15

Table 8002 - Battery specifications

Battery	Number of cells	Cell type	Rated capacity C <sub>1</sub> A (Ah)	Dimension mm (in)	Weight kg (lbs)	Power connector type	Lower Nut torque value N.m (lbf.in)	Upper Nut torque value N.m (lbf.in)	Nozzle length mm	Electrolyte water volume cm <sup>3</sup>
B1513CH1	20	<a href="#">CVH150KH</a>	15	364.0x138.5x196.0	15.3 (33.7)	↓	4.5 to 5.5 (39.8 to 48.7)	7 to 9 (62 to 80)	20	15
GB170	19	<a href="#">KO7.5KH</a>	7	251.6x117.3x117.5 (9.91x4.63x4.63)	7.6x16.8	↓	1.4 (12.15)	1.4 (12.15)	17	8

Table 8002 - Battery specifications

MS: Bayonet type vent-valves

#### 4. Vent-valve torque data

The table below lists the torque values for the different vent-valve types.

Vent-valve type	Torque	
	N.m	lbf.in
M8 vent-valves for VO3KHB, VP65KM, and VO12LKB cells	0.18 to 0.27	1.55 to 2.43
Other M8 vent-valves	0.29 to 0.31	2.57 to 2.74
MS vent-valves	Quarter-turn	Quarter-turn

Table 8003 - Vent-valve torque values

#### 5. BAC102 power connector torque table

The table below lists the torque values for all sub-components of the [BAC102 power connector assembly](#) style (P/N 100708) power connectors type [D](#) (refer to column [Power connector type](#) in table [8002 - Battery specifications](#)).

Part number	Description	Torque	
		N.m	lbf.in
011614	Nut, M22 x 1	16.0 to 20.0	142 to 176
011615	Nut, M18 x 1	12.0 to 14.0	106 to 124
160699	Screw, F/90, M4 x 8	1.0 to 1.4	9 to 12
101699	Screw, F/90, M4 x 12	1.0 to 1.4	9 to 12

Table 8004 - BAC102 power connector torque values

PAGE INTENTIONALLY LEFT BLANK



**SPECIAL TOOLS, FIXTURES, EQUIPMENT AND CONSUMABLES****1. Introduction**

This chapter is divided into two parts:

- The first part provides the list of special tools, fixtures and equipment needed to do the steps listed in the other chapters.
- The second part provides the listing of consumable materials used in this manual.

All listed items are identified in this manual by a standard code number:

- T## for tools, fixtures and equipment
- M## for consumable materials

**2. Standard tools**

The following items are recommended to do the procedures described in this manual. When necessary, equivalent substitutes may be used.

- Safety gloves
- Protective goggles
- Safety shoes
- Eye wash
- Protective apron
- Constant current charger (DC current range 0-60 A, minimum open DC voltage 40 V)
- Constant current load bank (DC current range 0-60 A, DC voltage range 1-40 V)
- Meg-ohmmeter (0-50 M $\Omega$  @ 250 VDC)
- Multimeter (Volt,  $\Omega$ , mA) 3.5 digits, 2,000 counts 1 % or better
- Climatic chamber (if the battery has a sensor)
- Torque wrench (insulated) 0-15 N.m (0-133 lbf.in)
- Standard mechanic's tools (insulated)
- Stiff bristle brush (non-metallic)
- Small paintbrush (non-metallic)
- Dry, compressed air source [less than 1.4 bar (20 psi)]
- Soft, lint free, clean cloth (at least two required)

### 3. Special tools

**NOTE: Equivalent tools can be used.**

#### 3-1. Special tool list

Tool #	Description	P/N (F6177)	P/N (09052)
T01	Universal vent-valve wrench	413876	093365-000
T02	Syringe with M8 nozzle 12 mm assembly	416228	020915-002
T02	Syringe with M8 nozzle 15 mm assembly	416229	-
T02	Syringe with M8 nozzle 17 mm assembly	411407	-
T02	Syringe with M8 nozzle 20 mm assembly	416231	020915-004
T02*	Syringe with M8 nozzle 20 mm assembly (specialized for CVH170KA cells)	-	025860-000
T02	Syringe with M8 nozzle 24 mm assembly	416233	-
T02	Syringe with M8 nozzle 33 mm assembly	416235	-
T02	Syringe with M8 nozzle 38 mm assembly	416236	-
T02	Syringe with MS nozzle 20 mm assembly	416232	020916-001
T02*	Syringe with MS nozzle 24 mm assembly	-	020916-002
T02*	Syringe with MS nozzle 38 mm assembly	416331	-
T03	Equalizing resistors	164829	022069-000
T04	Universal cell extraction tool	416159	017556-000
T05*	Vent-valve adapter for M8 vent-valve	458723	025098-000
T05*	Vent-valve adapter for quarter turn vent-valve (MS)	458728	024398-000
T05*	Vent-valve adapter for CVH170KA (quarter turn vent-valve / MS)	-	026756-000
-	Syringe	105112	-
-	M8 nozzle 12 mm (NP)	014590	-
-	M8 nozzle 15 mm (NP)	014591	-
-	M8 nozzle 17 mm (NP)	411407	-
-	M8 nozzle 20 mm (NP)	016544	-
*	M8 nozzle 20 mm (specialized for CVH170KA cells) (NP)	-	025859-000
-	M8 nozzle 24 mm (NP)	015778	-
-	M8 nozzle 33 mm (NP)	410199	-
-	M8 nozzle 38 mm (NP)	410233	-
-	MS nozzle 20 mm (NP)	104184	-
-	Wrench M18 for connector	414152	-
-	Wrench M22 for connector	414151	-

**Table 9001 - Special tool list**

\*Tool is not available in tool kits (must be purchased separately).

#### 3-2. Special tool kits

A special tool kit is available from Saft with the P/N 416161 (detailed in section [Special tool kit \(standard\)](#)) containing most special tools. An additional version of the tool kit designed for [BAC102 power connector assembly](#) is available with P/N 416160 (detailed in section [Special tool kit \(for BAC102 power connector assembly\)](#)).



**Figure 9001 - Tool kit**

3-2-1. Special tool kit (standard)

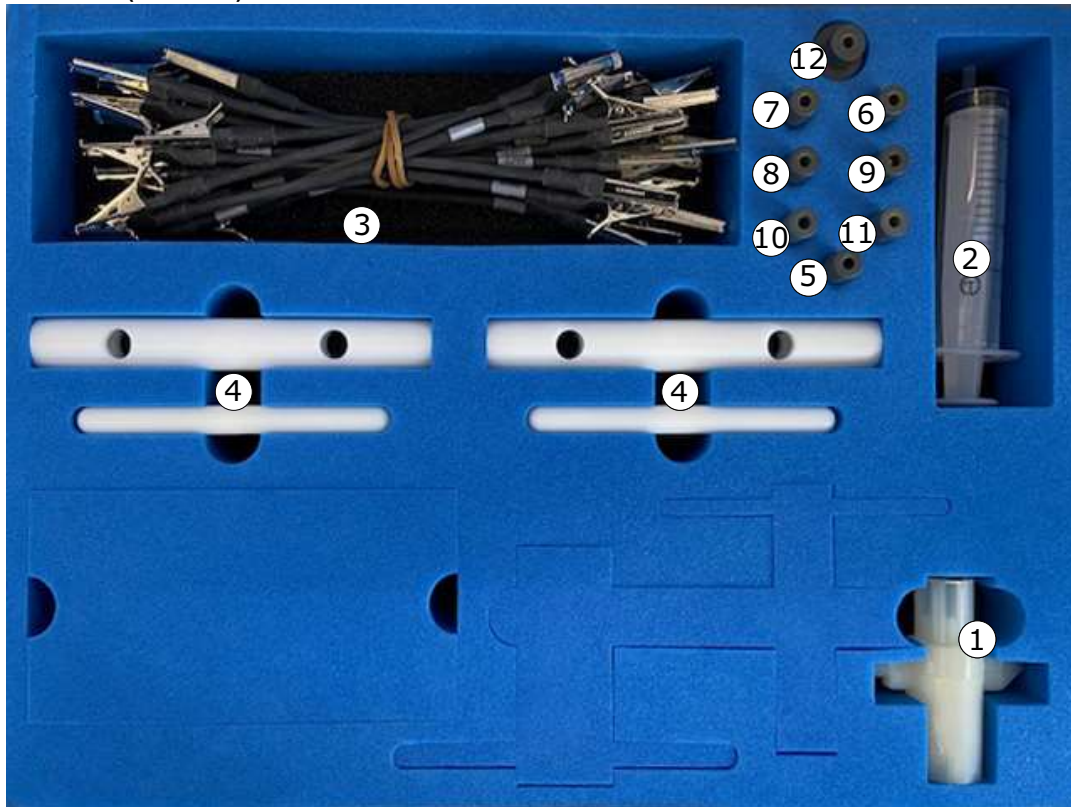

Figure 9002 - Special tool kit (P/N 416161)

Item #	Tool #	Description	P/N (F6177)	P/N (09052)
1	T01	Universal vent-valve wrench	413876	093365-000
2	-	Syringe	105112	-
2+5	T02	Syringe with M8 nozzle 12 mm assembly	416228	020915-002
2+6	T02	Syringe with M8 nozzle 15 mm assembly	416229	-
2+7	T02	Syringe with M8 nozzle 17 mm assembly	416230	-
2+8	T02	Syringe with M8 nozzle 20 mm assembly	416231	020915-004
2+9	T02	Syringe with M8 nozzle 24 mm assembly	416233	-
2+10	T02	Syringe with M8 nozzle 33 mm assembly	416235	-
2+11	T02	Syringe with M8 nozzle 38 mm assembly	416236	-
2+12	T02	Syringe with MS nozzle 20 mm assembly	416232	020916-001
3	T03	Equalizing resistors	164829	022069-000
4	T04	Universal cell extraction tool	416159	017556-000
5	-	M8 nozzle 12 mm (NP)	014590	-
6	-	M8 nozzle 15 mm (NP)	014591	-
7	-	M8 nozzle 17 mm (NP)	411407	-
8	-	M8 nozzle 20 mm (NP)	016544	-
9	-	M8 nozzle 24 mm (NP)	015778	-
10	-	M8 nozzle 33 mm (NP)	410199	-
11	-	M8 nozzle 38 mm (NP)	410233	-
12	-	MS nozzle 20 mm (NP)	104184	-

Table 9002 - Special tool kit (416161)

3-2-2. Special tool kit (for [BAC102 power connector assembly](#))

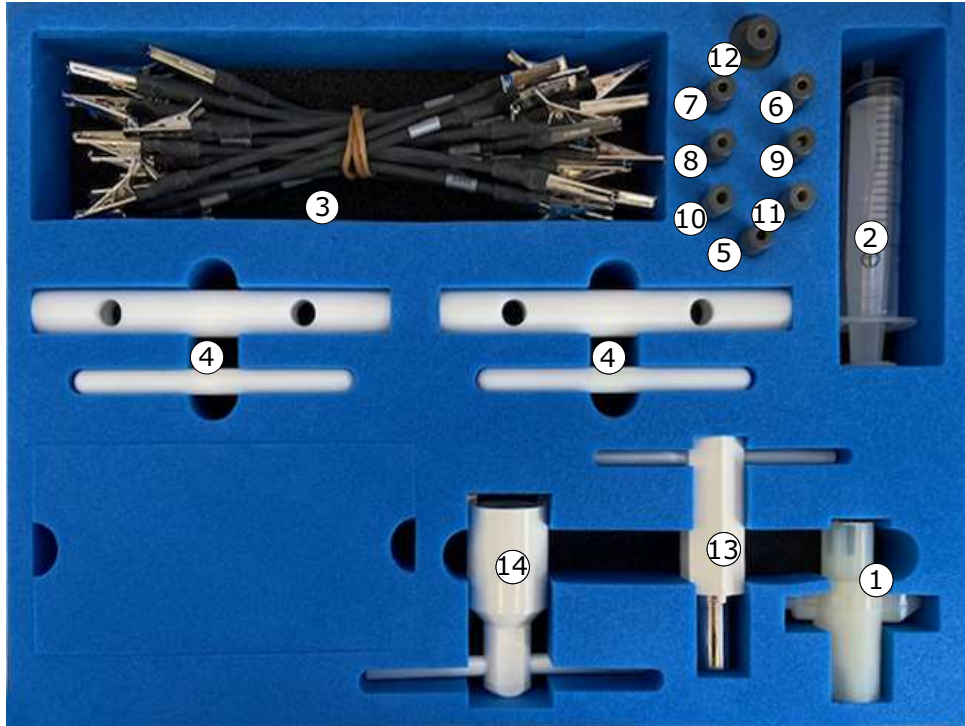

Figure 9003 - Special tool kit (P/N 416160)

Item #	Tool #	Description	P/N (F6177)	P/N (09052)
1	T01	Universal vent-valve wrench	413876	093365-000
2	-	Syringe	105112	-
2+5	T02	Syringe with M8 nozzle 12 mm assembly	416228	020915-002
2+6	T02	Syringe with M8 nozzle 15 mm assembly	416229	-
2+7	T02	Syringe with M8 nozzle 17 mm assembly	416230	-
2+8	T02	Syringe with M8 nozzle 20 mm assembly	416231	020915-004
2+9	T02	Syringe with M8 nozzle 24 mm assembly	416233	-
2+10	T02	Syringe with M8 nozzle 33 mm assembly	416235	-
2+11	T02	Syringe with M8 nozzle 38 mm assembly	416236	-
2+12	T02	Syringe with MS nozzle 20 mm assembly	416232	020916-001
3	T03	Equalizing resistors	164829	022069-000
4	T04	Universal cell extraction tool	416159	017556-000
5	-	M8 nozzle 12 mm (NP)	014590	-
6	-	M8 nozzle 15 mm (NP)	014591	-
7	-	M8 nozzle 17 mm (NP)	411407	-
8	-	M8 nozzle 20 mm (NP)	016544	-
9	-	M8 nozzle 24 mm (NP)	015778	-
10	-	M8 nozzle 33 mm (NP)	410199	-
11	-	M8 nozzle 38 mm (NP)	410233	-
12	-	MS nozzle 20 mm (NP)	104184	-
13	-	Wrench M18 for connector	414152	-
14	-	Wrench M22 for connector	414151	-

Table 9003 - Special tool kit (P/N 416160)

#### 4. Consumables

**NOTE: Equivalent alternatives can be used for list items.**

This paragraph describes the consumables used in the OMM.

MATERIAL CODE	DESIGNATION PARTNUMBER AND SPECIFICATION	MANUFACTURER OR SUPPLIER (NAME, ADDRESS, CODE)
M01	Distilled or deionized water (specification at +20 °C (+68 °F)): Clear, colorless and odorless while boiling Conductivity < 33 µS/cm 5 < pH < 7 Mn-COD < 30 mg/l (1.7 X 10 <sup>-5</sup> oz/in <sup>3</sup> ) (Chemical Oxygen Demand under potassium permanganate methodology): methodology to evaluate organic or mineral pollution) Chlorines Cl- < 5 mg/l (2.9 X 10 <sup>-6</sup> oz/in <sup>3</sup> ) Sulfates SO4-- < 10 mg/l (5.8 X 10 <sup>-6</sup> oz/in <sup>3</sup> ) Temperature for analysis and specifications are at +20 °C (+68 °F).  STORAGE: dry and clean container without any corrosion and damage; Temperature: +15 °C to +25 °C (+56 °F to +70 °F). Over 1 year of storage, do an analysis of the liquid.	Local vendor or in house production
M02	Neutral petroleum jelly Density @ +60 °C (+140 °F) Range = 0.840 - 0.866 kg/l (0.486 - 0.500 oz/in <sup>3</sup> ) Melting Point Range = +46 °C to +52 °C (+115 °F to +126 °F) Acidity/Alkalinity = Neutral to Litmus	Mineral Vaseline NATO: S 743 F: AIR 3565 US: VV-P-236A UK: DEF 2333
M03	Mild soap (pH 6.5 - 7.5)	Local vendor

**Table 9004 - Consumables**



PAGE INTENTIONALLY LEFT BLANK

## ILLUSTRATED PARTS LIST

### 1. Description

The Illustrated Parts List (IPL) contains a list and illustrations of the assemblies and detailed parts of the unit in disassembly sequence.

Table 10001 - [Illustrated Parts List \(IPL\) generic example](#) can be used to construct an illustrated parts list for a battery.

To determine the part number of a given part, refer to the provided illustration (figure [10001 - Ni-Cd aircraft battery](#)) and refer to the item number describing the part. The item number is used to locate the row for the respective part in table 10001 - [Illustrated Parts List \(IPL\) generic example](#).

To find the part number for a specific part, refer to the column [Reference Page](#) and navigate the hyperlinked page numbers to find the part number specific for that item number of the battery.

**NOTE: 6 digit part numbers formatted as ##### are sold under supplier cage code F6177. 9 digit part numbers formatted as #####-### are sold under supplier cage code 09052.**

Blank rows in the [Quantity per Assembly](#) column are specific to each battery. Fill these rows in with information specific to the battery.

**NOTE: Not all batteries are equipped with every part listed in the table [Illustrated Parts List \(IPL\) generic example](#). If a battery is not equipped with a specific part, the row for that part can be crossed out or ignored.**

Numbered parts of assemblies and sub-assemblies included in the list but not illustrated are identified by a hyphen (-) preceding the item number.

Nomenclature: the nomenclature is given with an indenture, to show how the parts and the assemblies are related to the overall assembly. These are the details:

1 2 3 4 5 6 7

Assembly

. Detailed parts for assembly

. Sub-assembly

. . Detailed parts for sub-assembly

. . Sub-sub-assembly

Non-procurable parts are denoted by the abbreviation NP placed at the extreme right-hand side of the last line of the item nomenclature.

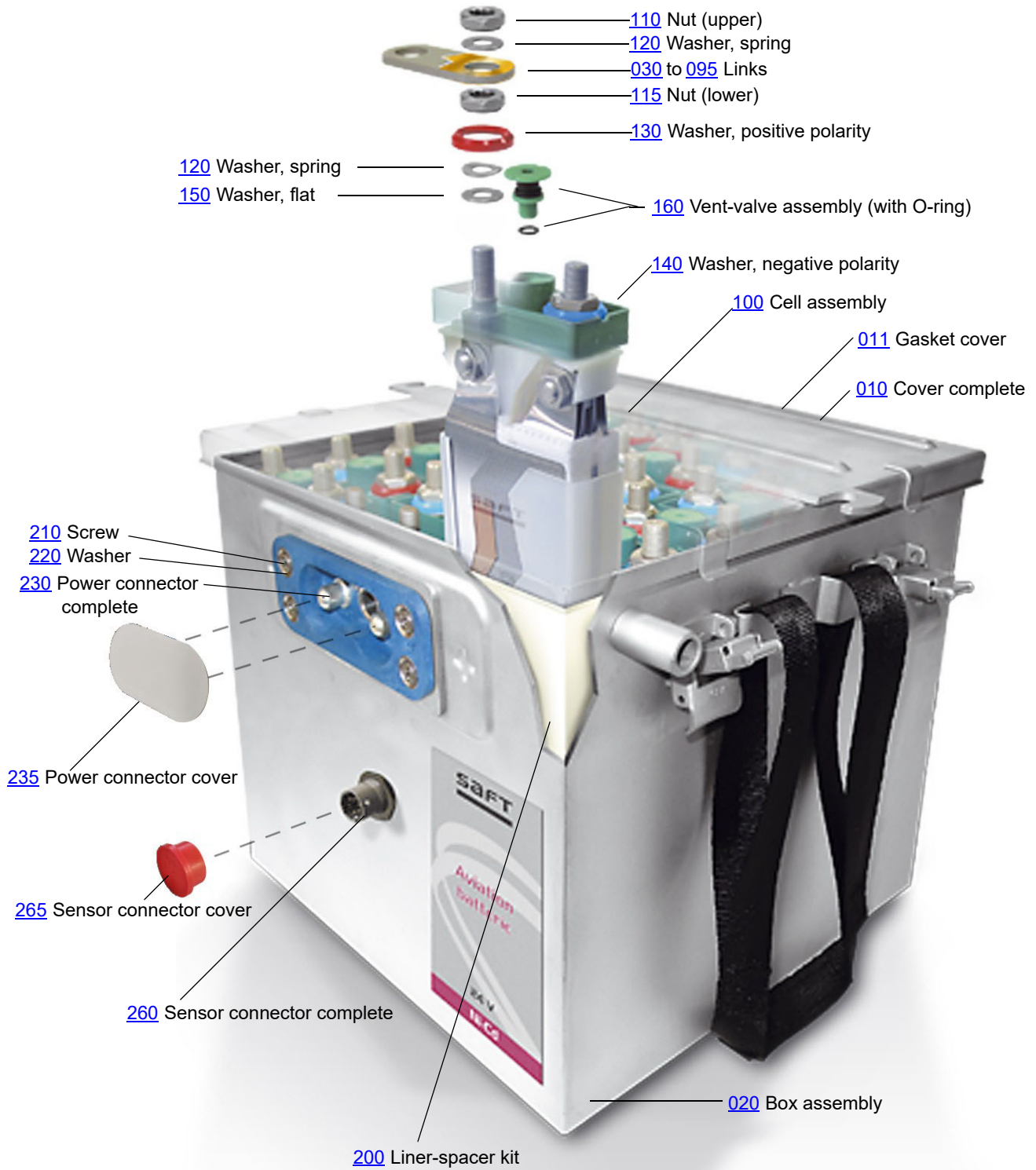

Figure 10001 - Ni-Cd aircraft battery



Figure Number	Item Number	Part Number	Airline Stock Number	Nomenclature 1 2 3 4 5 6 7	Quantity per Assembly	Reference Page
10001	<a href="#">-001</a>			BATTERY	-	<a href="#">page 10004</a>
	<a href="#">010</a>			. COVER COMPLETE	1	<a href="#">page 10004</a>
	<a href="#">011</a>			. . GASKET COVER NP	1	-
	<a href="#">020</a>			. BOX ASSEMBLY	1	<a href="#">page 10004</a>
	<a href="#">030</a>			. LINK INTER-CELL		<a href="#">page 10012</a>
	<a href="#">040</a>			. LINK INTER-CELL		<a href="#">page 10012</a>
	<a href="#">050</a>			. LINK INTER-CELL		<a href="#">page 10012</a>
	<a href="#">060</a>			. LINK INTER-CELL		<a href="#">page 10012</a>
	<a href="#">070</a>			. LINK INTER-CELL		<a href="#">page 10012</a>
	<a href="#">080</a>			. LINK INTER-CELL		<a href="#">page 10012</a>
	<a href="#">090</a>			. LINK INTER-CELL		<a href="#">page 10012</a>
	<a href="#">095</a>			. LINK INTER-CELL		<a href="#">page 10012</a>
	<a href="#">100</a>			. CELL ASSEMBLY		<a href="#">page 10004</a>
	<a href="#">110</a>			. . NUT, UPPER		<a href="#">page 10024</a>
	<a href="#">115</a>			. . NUT, LOWER		<a href="#">page 10024</a>
	<a href="#">120</a>			. . WASHER, SPRING		<a href="#">page 10024</a>
	<a href="#">130</a>			. . WASHER, POSITIVE POLARITY		<a href="#">page 10024</a>
	<a href="#">140</a>			. . WASHER, NEGATIVE POLARITY		<a href="#">page 10024</a>
	<a href="#">150</a>			. . WASHER, FLAT		<a href="#">page 10024</a>
	<a href="#">160</a>			. . VENT-VALVE ASSEMBLY (VENT-VALVE WITH O-RING)		<a href="#">page 10024</a>
	<a href="#">200</a>			. LINER-SPACER KIT		<a href="#">page 10004</a>
	<a href="#">210</a>			. SCREW		<a href="#">page 10004</a>
	<a href="#">220</a>			. WASHER		<a href="#">page 10004</a>
	<a href="#">230</a>			. POWER CONNECTOR COMPLETE		<a href="#">page 10004</a>
	<a href="#">235</a>			. POWER CONNECTOR COVER		*
	<a href="#">-240</a>			. GASKET		<a href="#">page 10004</a>
	<a href="#">-250</a>			. CABLE TIES		**
	<a href="#">260</a>			. SENSOR CONNECTOR COMPLETE		<a href="#">page 5010</a>
	<a href="#">265</a>			. SENSOR CONNECTOR COVER NP		<a href="#">page 10026</a>
	<a href="#">-270</a>	415690		. ONE-WAY VALVE		-

Table 10001 - Illustrated Parts List (IPL) generic example

\*Replacement power connector covers for MS3509 style connectors (refer to Type of Connector in table [8002 - Battery specifications](#)) can be procured by purchasing Saft part number 415059, 166925, or 093362-000, or purchased from an approved supplier of Rebling part number 700220.

\*\*Cable ties can be purchased by ordering Saft part number 116056 or 092815-000 or procured from another supplier of military standard reference MS18034-4.

## ILLUSTRATED PARTS LIST

## 2. Battery parts list

Battery	Battery part number	Cell assembly (100)	(010) + (020) Box and cover	(010) Cover	(020) Box	(200) Liner-spacer kit	(210) Screw	(220) Washer	(230) Power connector complete	(-240) Gasket
19VO3KHB	414547	<a href="#">VO3KHB</a>	414550	414557	414551	414562	413207	-	414570	-
20VO3KHB	414548	<a href="#">VO3KHB</a>	414550	414557	414551	414562	413207	-	414570	-
151CH2	415237	<a href="#">CVH150KH</a>	413926	414426	414417	414453	-	-	414482	-
176CH	025897-000	<a href="#">CVH170KA</a>	-	016204-001	025915-000	020874-000	013616-000	-	021791-000	100713 009384-000
176CH6	025898-000	<a href="#">CVH170KA</a>	-	015722-000	025931-000	020874-000	093616-000	-	021741-000	100713 009384-000
178CH1	416488	<a href="#">CVH170KA</a>	416491	106337	416490	410996	100523	100430	102226	100713 009384-000
181CH	414254 024587-000	<a href="#">CVH180KH</a>	414288	414287	414284	414289	100431	100430	410251	100713 009384-000
272CH1	415188	<a href="#">CVH271KH</a>	415910	415912	415911	415202	-	-	414482	-
276CH	414732	<a href="#">CVH271KH</a>	414801	114318	413075	412650	100431	100430	160510	100713 009384-000
276CH7	415779	<a href="#">CVH271KH</a>	415782	114318	415781	415783	100431	100430	102226	-
276CH10	415957	<a href="#">CVH271KH</a>	415782	114318	415781	411827	100431	100430	102226	-
276CH23	415959	<a href="#">CVH271KH</a>	416104	114318 015697-00	415960 025944-000	411827 020795-000	100431 093616-000	100430	102226 021741-000	-
345CD1	415241	<a href="#">CVD34KH</a>	415304			415345	100431	100430	411075	-
405CH3	415956	<a href="#">CVH400KA</a>	416011	413791	416012	413714	100431	100430	102392 021740-000	415059
407CH5	415007	<a href="#">CVH400KA</a>	415786	413791	415784	413714	100431	100430	102392 021740-000	100713 009384-000
407CH9	024947-000	023413-000	-	015599-000	024949-000	022369-000	092178-000	091924-000	022078-000	100713 009384-000
437CH14	025776-000	<a href="#">CVH430KA</a>	-	025778-000	025777-000	-	093616-000	-	021740-000	100713 009384-000
438CH2	025899-000	<a href="#">CVH430KA</a>	-	025396-000	025932-000	019919-000	093616-000	-	021740-000	100713 009384-000
447CH1	415538	<a href="#">CVH441KH</a>	412733	114278	412744	411424	100431	100430	102392 021740-000	100713 009384-000
447CH3	416441	<a href="#">CVH441KH</a>	416445	114300	416444	416496	100431	100430	102392 021740-000	100713 009384-000
447CH8	416487	<a href="#">CVH441KH</a>	412743	114300	412744	416496	100431	100430	102392 021740-000	100713 009384-000
505CH3	415907	<a href="#">CVH500KA</a>	-	415014	415106	415016	100431	100430	415156	415059
606	410689	<a href="#">VP65K</a>	165701	165699	120148	411684	120170	100166	163292	-
615	410766	<a href="#">VP65K</a>	167738	167726	167722	-	-	167520	167727	-
616	411146	<a href="#">VP65K</a>	411147	411306	411151	411343	108045	410456	411303	-
653	167327	<a href="#">VP65K</a>	410181	-	-	412656	108045	107644	160809	-
666	410705	<a href="#">VP65K</a>	415705	410707	410706	415659	-	-	-	-
1277	100504	<a href="#">VP120KH-MS</a>	114453	100514	100505	411707	102129	078011	102057	100713 009384-000
1277-1	115944	<a href="#">VP120KHB</a>	118105	100514	118101	411707	100523	100430	102057	100713 009384-000
1277-3	414140	<a href="#">VP120KHB</a>	118105	100514	118101	411707	100523	100430	102057	100713 009384-000

Table 10002 - Battery parts list



Battery	Battery part number	Cell assembly (100)	(010) +(020) Box and cover	(010) Cover	(020) Box	(200) Liner-spacer kit	(210) Screw	(220) Washer	(230) Power connector complete	(-240) Gasket
1606	161185	<a href="#">VP160KM</a>	410825	410823	410822	412230	-	-	-	-
1608	410407	<a href="#">VHP170KH-3</a>								
1608-1	410075	<a href="#">VHP170KH-3</a>	410825	410824	410822	412230	-	-	-	-
1656	015700-000	<a href="#">VP160KH</a>	-	015722-000	021760-000	020874-000	093616-000	-	021741-000	100713 009384-000
1656-1	114769 017390-000	<a href="#">VP160KH</a>	167601	106337	115737 021761-000	410996	100523	100430	102226	-
1656-2	164747	<a href="#">VP160KH</a>	167601	106316	115737 021761-000	410996	100523	100430	102226	-
1656-5	410378	<a href="#">VP160KH-SQ</a>	167601	106316	115737 021761-000	410996	100523	100430	102226	-
1658	410385 024770-000	<a href="#">VHP170KH-3</a>	114607	106337	106312	410996	100523	100430	102226 021741-000	009384-000
1658-2	410231	<a href="#">VHP170KH-3</a>	167601	106316	115737 021761-000	412637	100523	100430	102226	-
1666-1	167598	<a href="#">VP160KM</a>	166893	166892	166815	411226	-	-	-	-
1718	414445	<a href="#">VHP170KH-3</a>	414468	414469	414446	414456	100431	100430	102226	100713 009384-000
1756	023470-000	<a href="#">VP170KH</a>	-	023467-000	021765-000 018248-000	020874-000 025340-000	093616-000	-	021741-000	100713 009384-000
2353-1	114733	<a href="#">VO23KH</a>	114571	114910	114572	412648	-	-	100897	-
2371	100429	<a href="#">VO23KH</a>		100421	100419	411425	100431	100430	160510	-
2371-1	114763	<a href="#">VO23KH</a>	115917	114318	115731	411940	100431	100430	102226	100713 009384-000
2371-2	162899	<a href="#">VO23KH</a>	115917	114318	115731	411940	100431	100430	102226	100713 009384-000
2371-5	411247 018465-000	<a href="#">VO23KH</a>	115917	114318	115731	412649	100431	100430	102226	100713 009384-000
2371-6	410696	<a href="#">VO23KH-SQ</a>	115917	114318	115731	411827	100431	100430	102226	100713 009384-000
2371-7	411777	<a href="#">VO23KH-SQ</a>	411792	114318	411791	411425	100431	100430	102226	100713 009384-000
2376	105428	<a href="#">VP230KH</a>	114301	114318	100419	411425	100431	100430	102226	100713 009384-000
2376-1	114765 017490-000	<a href="#">VP230KH</a>	115917	114318	115731	411940	100431	100430	102226	100713 009384-000
2376-2	165603 019330-000	<a href="#">VP230KH</a>	115917	114318	115731	412649	100431	100430	102226	100713 009384-000
2376-4	410862 018804-000	<a href="#">VP230KH</a>	410536	114318 015697-000	410535 021757-000	411426	100431 093616-000	100430	102226 021741-000	100713 009384-000
2376-7	412942	<a href="#">VP230KH</a>	410536	114318	410535	413459	100431	100430	102226	100713 009384-000
2376-8	413465	<a href="#">VP230KH</a>	413074	114318	413077	412642	100431	100430	102226	100713 009384-000
2376-10	023828-000	<a href="#">VP230KH</a>	-	015697-000	024042-000	020795-000	093616-000	-	021741-000	100713 009384-000

Table 10002 - Battery parts list (continued)



Battery	Battery part number	Cell assembly (100)	(010) +(020) Box and cover	(010) Cover	(020) Box	(200) Liner-spacer kit	(210) Screw	(220) Washer	(230) Power connector complete	(-240) Gasket
2378	166851	<a href="#">VHP260KH-3</a>	166863	166593	100419	411225	100431	100430	102226	100713 009384-000
2386-1	023773-000	<a href="#">VP200KHB</a>	-	023797-000	023794-000	-	092100-000	091607-000	006631-026	009384-000
2500	103261	<a href="#">VO25KA</a>	161010	102001	103262	412651	102013	100433	043124	-
2506-1	116129	<a href="#">VP250KH</a>	116128	115593	116127	412652	116386	126387	100708*	-
2506-2	412670	<a href="#">VP250KH</a>	412698	115593	412699	413355	116386	116367	100708*	-
2522	412920	<a href="#">VO25KA-C</a>	114363	103388	103377	412458	100431	100430	102226	-
2708-1	411621	<a href="#">VHP270KH-3</a>	411754	165888	411755	411757	160699 [3] 101699 [1]	-	100708*	-
2708-2	412212	<a href="#">VHP270KH-3</a>	412218	165888	412217	412213	160699 [3] 101699 [1]	-	100708*	-
2778	166130	<a href="#">VHP270KH-3</a>	166259	166260	166316	411428	100431	100430	102392 021740-000	100713 009384-000
2778-2	410001	<a href="#">VHP270KH-3</a>	411287	102295	166549	411941	100431	100430	102392 021740-000	100713 009384-000
2778-5	410868	<a href="#">VHP270KH-3</a>	410867	114300	410866	411941	100431	100430	102392 021740-000	100713 009384-000
2778-10	413211	<a href="#">VHP270KH-3</a>	166457	166260	412158	411941	100431	100430	102392 021740-000	100713 009384-000
2778-15	413329	<a href="#">VHP270KH-3</a>	411287	114300	166459	411941	100431	100430	102392 021740-000	100713 009384-000
2778-18	413658	<a href="#">VHP270KH-3</a>	413816	114300	413826	413817	100431	100430	102392 021740-000	100713 009384-000
4000A1	114098 114099 018383-000	<a href="#">VO40KH</a>	112804	113995	106516	412653	116386	116387	100708*	-
4000A1-1	116104 116105 018684-000	<a href="#">VO40KH</a>	116103	113995	116102	412653	116386	116387	100708*	-
4002	414162	<a href="#">VO40KH-C</a>	112804	113915	106516	412653	116386	116387	100708*	-
4006A	162041	<a href="#">VP400KH*</a>	112804	106521	106516	412653	116386	116387	100708*	-
4006A-1	162707 162708	<a href="#">VP400KH*</a>	116103	106521	116102	412653	116386	116387	100708*	-
4008-1	411248	<a href="#">VHP430KH-3</a>	116103	113995	116102	412653	116386	116387	100708*	-
4015CH11	024227-000	<a href="#">CVH400KA</a>	-	024456-000	024455-000	-	093616-000	-	021740-000	-
4017CH-1	023789-000	<a href="#">CVH400KA</a>	-	015924-003	024050-000	-	015579-000	015577-000	022078-000	-
4050A1-1	114760	<a href="#">VO40KH</a>	115991	102922	115992	412657	-	-	100897	-
4071	102390 016592-000	<a href="#">VO40KH</a>	114278	114300 015599-000	102391	411424	100431 093616-000	100430	102392 021740-000	100713 009384-000
4071-1	114725 018100-000	<a href="#">VO40KH</a>	115963	114300 015599-000	115732 021786-000	411424	100431	100430	102392 021740-000	100713 009384-000
4071-2	166731 019513-000	<a href="#">VO40KH</a>	115963	114300 015599-000	115732 021701-000	411424 019919-000	100431 093616-000	100430	102392 021740-000	100713 009384-000
4071-3	023044-000	<a href="#">VO40KH</a>	-	021003-000	023058-000	019919-000	093616-000	-	021740-000	009384-000
4072	412931	<a href="#">VO40KH-C</a>	114278	114300	102391	411424	100431	100430	102392 021740-000	100713 009384-000

Table 10002 - Battery parts list (continued)

ILLUSTRATED PARTS LIST

Battery	Battery part number	Cell assembly (100)	(010) +(020) Box and cover	(010) Cover	(020) Box	(200) Liner-spacer kit	(210) Screw	(220) Washer	(230) Power connector complete	(-240) Gasket
4076-2	160229	<a href="#">VP400KH*</a>	115963	114300	161088	411424	100431	100430	102392 021740-000	100713 009384-000
4076	102446 015580-000	<a href="#">VP400KH*</a>	114278	114300 015599-000	117928 021495-000	411424 019919-000	100431 093616-000	100430	102392 021740-000	100713 009384-000
4076-1	115967 016987-000	<a href="#">VP400KH*</a>	115963	114300 015599-000	115732 021494-000	411424 019919-000	100431 093616-000	100430	102392 021740-000	100713 009384-000
4076-3	117926 017445-000	<a href="#">VP400KH*</a>	117927	114300 015599-000	117928 021495-000	411424 019919-000	100431 093616-000	100430	102392 021740-000	100713 009384-000
4076-8	017690-000	<a href="#">VP400KH*</a>	117927	114300 015599-000	117928 021495-000	411424 019919-000	100431 093616-000	100430	102392 021740-000	100713 009384-000
4076-9	167556 017692-000	<a href="#">VP400KH*</a>	167711	102295	167633	411424	100431	100430	102392 021740-000	-
4076-11	019368-000 023515-000	<a href="#">VP400KH*</a>	-	015599-000	021500-000 023516-000.	019919-000	093616-000	-	021740-000	100713 009384-000
4076-12	019500-000	<a href="#">VP400KH*</a>	-	015599-000	021501-000	019919-000	093616-000	-	021740-000	100713 009384-000
4076-13	023322-000	<a href="#">VP400KH*</a>	-	021003-000	023316-000	019919-000	093616-000	-	021740-000	100713 009384-000
4076-15	024555-000	<a href="#">VP400KH*</a>	-	015599-000	024556-000	019919-000	093616-000	-	021740-000	100713 009384-000
4076-16	413014	<a href="#">VP400KH*</a>	413015	114300	413016	411424	100431	100430	102392 021740-000	100713 009384-000
4076-17	413042	<a href="#">VP400KH*</a>	413237	114300	413238	411424	100431	100430	102392 021740-000	100713 009384-000
4076-18	-	<a href="#">VP400KH-SQ</a>	-	-	-	-	-	-	-	-
4077	102289	<a href="#">VP400KH-MS</a>	114268	102295	102290	412658	100523	100430	410690	100713 009384-000
4078	410408 018718-000	<a href="#">VHP430KH-3</a>	114278	114300	102391	021714-000	100431	100430	102392 021740-000	100713 009384-000
4078-1	410090	<a href="#">VHP430KH-3</a>	410036	166260	410035	411424	100431	411430	102392 021740-000	100713 009384-000
4078-5	410421	<a href="#">VHP430KH-3</a>	410036	166260	116732	411424	100431	100430	102392 021740-000	100713 009384-000
4078-6	020678-000	<a href="#">VHP430KH-3</a>	-	015599-000	021747-000	019919-000	093616-000	-	021740-000	100713 009384-000
4078-9	021937-000	<a href="#">VHP430KH-3</a>	-	015599-000	022042-000	019919-000	093616-000	-	021740-000	100713 009384-000
4078-10	022019-000	<a href="#">VHP430KH-3</a>	-	015599-000	022023-000	019919-000	093616-000	-	021740-000	100713 009384-000
4078-11	413347	<a href="#">VHP430KH-3</a>	115963	114300	115732	411424	100431	100430	102392 021740-000	100713 009384-000
4078-13	022658-000 412437	<a href="#">VHP430KH-3</a>	410778	114300	410764	411424	100431	100430	102392 021740-000	100713 009384-000
4078-16	413337	<a href="#">VHP430KH-3</a>	412743	114300	412744	411424	100431	100430	102392 021740-000	100713 009384-000
4078-18	413228	<a href="#">VHP430KH-3</a>	115963	114300 015599-000	115732 023695-000	411424	100431 015579-000	100392 022228-000	102392 021740-000	100713 009384-000

Table 10002 - Battery parts list (continued)



Battery	Battery part number	Cell assembly (100)	(010) +(020) Box and cover	(010) Cover	(020) Box	(200) Liner-spacer kit	(210) Screw	(220) Washer	(230) Power connector complete	(-240) Gasket
4078-19	023694-000	<a href="#">VHP430KH-3</a>	-	015599-000	023695-000	021714-000	093616-000	-	021740-000	100713 009384-000
4078-21	413659	<a href="#">VHP430KH-3</a>	413237	114300	413238	411424	100431	100430	102392 021740-000	100713 009384-000
4079	166131	<a href="#">VHP370KA-3</a>	166262	166324	166232	411424	100431	100430	102392 021740-000	100713 009384-000
4079-1	410138	<a href="#">VHP370KA-3</a>	410147	114300	410145	411124	100431	100430	102392 021740-000	100713 009384-000
4079-6	413210	<a href="#">VHP370KA-3</a>	412743	114300	412744	411424	100431	100430	102392 021740-000	100713 009384-000
4079-9	413034	<a href="#">VHP370KA-3</a>	413094	114300	413086	411424	100431	100430	102392 021740-000	100713 009384-000
4079-10	024976-000	<a href="#">VHP370KA-3</a>	-	015599-000	025750-000	021714-000	093616-000	-	021740-000	100713 009384-000
4080	100162	<a href="#">VO40KH</a>	018301			412660	contact saft	contact saft	contact saft	-
4317CH1	025930-000	<a href="#">CVH430KA</a>	-	015924-003	025929-000	019736-000	093616-000	-	022078-000	100713 009384-000
4410CH1	416017	<a href="#">CVH441KH</a>	112804	113995	106516	411344	100431	100430	116426	-
4417CH14	024904-000	<a href="#">CVH441KH</a>	-	021003-000	024971-000	021714-000	093616-000	-	021740-000	100713 009384-000
5035CH4	416614	<a href="#">CVH500KA</a>	416629	415014	416628	415016	100431	100430	102392 021740-000	415059
5512CH1	025654-000	<a href="#">CVH500KA</a>	-	022043-000	025656-000	025656-000	093616-000	-	022012-000	093422-000
6206	412917	<a href="#">VP65K</a>	411125			411684	411685	100430	411667	
8050	100344	<a href="#">VO80KH</a>	114831	106598	014459	-	-	-	-	-
12277-2	020413-000	<a href="#">VP120KHB</a>	-	020425-000	021767-000	024731-000	093616-000	-	006631-026	100713 009384-000
16106-1	167554	<a href="#">VP160KM-SQ</a>	410831	410830	410826	412230	-	-	-	-
16108-1	412826	<a href="#">VHP170KH-3-SQ</a>	410831	410830	410826	412230	-	-	-	-
16156	017230-000	<a href="#">VP160KH</a>	-	018263-000	021763-000	020875-000	093616-000	-	022423-000	-
16156-1	411103 018090-000	<a href="#">VP160KH</a>	-	018263-000	021764-000	020875-000	093616-000	-	022423-000	-
16158	411105	<a href="#">VHP170KH-3</a>	411024	411020	411022	411301	100523	100430	411075	-
16256-3	023510-000	<a href="#">VP160KH</a>	-	023692-000	023511-000	020875-000	093015-004	091938-000	019384-000	019403-000
16258	411431	<a href="#">VHP170KH-3</a>	411266	410855	411449	411423	100523	100430	411422	-
23171-4	410530	<a href="#">VO23KH</a>	410536	114318	410535	411425	100431	100430	102226	100713
23175	112972	<a href="#">VP230KH</a>	114557	114318 015697-000	116767 021777-000	412642 020795-000	100431 093616-000	100430	102226 021741-000	100713 009384-000
23176	112695 016585-000	<a href="#">VP230KH</a>	114557	114318 015697-000	116767 021777-000	412642 020795-000	100431 093616-000	100430	102226 021741-000	100713 009384-000
23378	410022	<a href="#">VHP260KH-3</a>	410021	410020	161282	411335	165696	100430	102226	100713 009384-000
23476	160786	<a href="#">VP230KH</a>	161656	161637	161639	412646	165696	100430	102226	100713 009384-000

Table 10002 - Battery parts list (continued)



Battery	Battery part number	Cell assembly (100)	(010) +(020) Box and cover	(010) Cover	(020) Box	(200) Liner-spacer kit	(210) Screw	(220) Washer	(230) Power connector complete	(-240) Gasket
23478	412811	<a href="#">VP230KH</a>	161656	161637	161639	412646	165696	100430	102226	100713 009384-000
23491	410426	<a href="#">VO23KH</a>	415609	410436	415596	412647	100431	100430	102226	-
23491-3	410861	<a href="#">VO23KH</a>	415609	410436	415596	412647	100431	100430	102226	-
23491-4	414915	<a href="#">VO23KH</a>	414924	414925	414903	414916	100431	100430	102226	-
23498-1	413555	<a href="#">VHP260KH-3</a>	415609	410436	415596	412647	100431	100430	102226	-
23576-1	023521-000	<a href="#">VP230KH</a>	-	015697-000	021781-000	020795-000	093616-000	-	021741-000	100713 009384-000
23576-2	023525-000	<a href="#">VP230KH</a>	-	015697-000	023576-000	020795-000	027741-000	-	021741-000	100713 009384-000
23676-2	023498-000	<a href="#">VP230KH</a>	-	019268-000	023497-000	022745-000	093616-000	-	022367-000	100713 009384-000
23678-1	411826	<a href="#">VHP260KH-3-SQ</a>	115917	114318	115731	411827	100431	100430	102226	100713 009384-000
23678-2	412546	<a href="#">VHP260KH-3-SQ</a>	411792	114318	411791	411425	100431	100430	102226	100713 009384-000
23678-3	413021	<a href="#">VHP260KH-3-SQ</a>	413074	114318	413077	411827	100431	100430	102226	100713 009384-000
25106	116110	<a href="#">VP250KH</a>	115591	115593	115592	412652	100431	100430	115947	-
25106-2	119708	<a href="#">VP250KH</a>	115591	115593	115592	412652	100431	100430	115947	-
26108-3	414092	<a href="#">VHP260KH-3</a>	414096	-	-	413471	-	-	-	-
26108-4	414136	<a href="#">VHP260KH-3</a>	413892	-	-	413471	-	-	-	-
26108-5	414184	<a href="#">VHP260KH-3</a>	413892	-	-	416200	-	-	-	-
26108-7	415243	<a href="#">VHP260KH-3</a>	416322	-	-	416200	-	-	-	-
26308-1	413335	<a href="#">VHP260KH-3</a>	413396	413387	413378	413397	100431	100430	102226	100713 009384-000
26408-1	413384	<a href="#">VHP260KH-3</a>	413438	413387	413434	413397	100431	100430	102226	100713 009384-000
26508	414512	<a href="#">VHP260KH-3</a>	414877	414876	414881	414535	-	-	414953	-
26608	414742	<a href="#">VHP260KH-3</a>	414878	414876	414750	414535	-	-	414953	-
26708	414743	<a href="#">VHP260KH-3</a>	414878	414876	414750	414535	-	-	414952	-
27278-2	411282	<a href="#">VHP270KH-3-SQ</a>	411287	114300	166459	411941	100431	100430	102392 021740-000	100713 009384-000
27478	412755	<a href="#">VHP270KH-3</a>	412802	412803	412791	412806	100431	100430	102392	100713 009384-000
27578-2	024470-000	<a href="#">VHP270KH-3</a>	-	015599-000	024472-000	-	093616-000	-	021740-000	100713 009384-000
40042	411200	<a href="#">VOEC40KH</a>	411322	411325		411297	100431	100430	411925	-
40100A	410000	<a href="#">VO40KH</a>	112804	113995	106516	411344	100431	100430	116426	-

Table 10002 - Battery parts list (continued)

## ILLUSTRATED PARTS LIST

Battery	Battery part number	Cell assembly (100)	(010) + (020) Box and cover	(010) Cover	(020) Box	(200) Liner-spacer kit	(210) Screw	(220) Washer	(230) Power connector complete	(-240) Gasket
40100-1	166768	<a href="#">VO40KH</a>	112804	113995	106516	412654	100431	100430	116426	-
40100-2	414279	<a href="#">VHP430KH-3</a>	112804	113995	106516	411344	100431	100430	116426	-
40152	100453	<a href="#">VO40KH</a>	114520	100476	100455	412655	100431	100430	160510	100713 009384-000
40180-2	414279	<a href="#">VHP430KH-3</a>	112804	113995	106516	411344	100431	100430	116426	-1656-21
40142	411179	<a href="#">VOEC40KH</a>	411322	-	-	411297	100431	100430	411295	-
40153	114628	<a href="#">VP400KH*</a>	114520	100476	100455	412655	100431	100430	102227	100713 009384-000
40178	414219	<a href="#">VHP430KH-3</a>	411171	411172	411111	411424	100431	100430	102392 021740-000	100713 009384-000
40178-7	412586	<a href="#">VHP430KH-3</a>	412600	412601	412589	412618	100431	100430	102392 021740-000	100713 009384-000
40178-21	414377	<a href="#">VHP430KH-3</a>	415433	415443	414521	411424	100431	100430	102392 021740-000	100713 009384-000
40200	430801	<a href="#">VO40KH</a>	165889	165888	166277	410995	160699	-	100708*	-
40200-1	414690	<a href="#">VO40KH</a>	414692	165888	414691	410995	160699	-	100708*	-
40206-2	167468	<a href="#">VP400KH*</a>		165877	167543	410995	-	-	100708*	-
40208	166185	<a href="#">VHP430KH-3</a>	166265	166269	166266	410995	160699 101699	-	100708*	-
40208-1	166409	<a href="#">VHP430KH-3</a>	167523	165888	167522	410995	-	-	100708*	-
40208-2	410089	<a href="#">VHP430KH-3</a>	167523	165888	167522	410995	-	-	100708*	-
40208-4	410677	<a href="#">VHP430KH-3</a>	167523	165888	167543	410995	160699 101699	-	100708*	-
40208-5	410687	<a href="#">VHP430KH-3</a>	167523	165888	167543	411314	160699 101699	-	100708*	-
40208-6	411978	<a href="#">VHP430KH-3</a>	167523	165888	167522	410995	160699 101699	-	100708*	-
40208-7	413095	<a href="#">VHP430KH-3SQ</a>	167523	165888	167522	410995	-	-	100708*	-
40209-2	410118	<a href="#">VHP370KA-3</a>	167523	165888	167522	410995	160699 101699	-	100708*	-
40278-2	411289	<a href="#">VHP430KH-3SQ</a>	115963	114300	115732	411424	100431	100430	102392 021740-000	100713 009384-000
40278-14	415738	<a href="#">VHP430KH-3</a>	412767	102295	412768	411424	100431	100430	413861	100713 009384-000
40253	019654-000	<a href="#">VP340KA</a>	021424-000	020719-000	021424-000	022041-000	093616-000	-	022078-000	009384-000
40300	412473	<a href="#">VO40KH-3</a>	412537	412536	412529	412535	116386	116387	100708*	-
40306	166906	<a href="#">VP400KH-SQ</a>	112804	113995	106516	412653	116386	116387	100708*	-
40342	411652	<a href="#">VOEC40KH</a>	411664	411663	411654	411665	100431	100430	411419	-
40371	411393	<a href="#">VOEC40KH</a>	411420	411408	411372	411298	100431	100430	411419	-

Table 10002 - Battery parts list (continued)





Battery	Battery part number	Cell assembly (100)	(010) +(020) Box and cover	(010) Cover	(020) Box	(200) Liner-spacer kit	(210) Screw	(220) Washer	(230) Power connector complete	(-240) Gasket
40408	410422	<a href="#">VHP430KH-3</a>	167523	165888	167522	-?-	160699 101699	-	100708*	-
40478-1	021173-000	<a href="#">VHP430KH-3</a>	-	021607-000	021605-000	022006-000	093616-000	-	021740-000	009384-000
40508-1	413203	<a href="#">VHP430KH-3SQ</a>	414224	414223	413177	413204	100431	100430	411715	-
40576	410860 459509 023311-000	<a href="#">VP400KH-AC</a>	411090	411089 018262-000	411076 023313-000	411508 021442-000	100431 093616-000	100430 -	167174 022077-000	100713 009384-000
40576-3	017710-000	<a href="#">VP400KH-AC</a>	-	018262-000	021792-000	021442-000	093616-000	-	022077-000	100713 009384-000
40576-14	023663-000	<a href="#">VP400KH*</a>	023664-000	018262-000	021793-000	021442-000	093616-000	-	022077-000	100713 009384-000
40578-1	022667-000	<a href="#">VHP430KH-3</a>	-	015599-000	022666-000		093616-000	-	021740-000	009384-000
40678-4	023450-000	<a href="#">VHP450KH-1</a>	-	015599-000	023486-000	019919-000	093616-000	-	021740-000	100713 009384-000
40776	023673-000	<a href="#">VP400KH-AC</a>	-	018262-000	023674-000	020581-000	093616-000	-	022077-000	100713 009384-000
40778-11	413041	<a href="#">VHP430KH-3</a>	413054	411405	413055	411428	100431	100430	102392 021740-000	100713 009384-000
401076	023677-000	<a href="#">VP400KH-AC</a>	-	018128-000	021797-000	021442-000	097197-000	091607-000	017689-000	100713 009384-000
A275CH1	415808	<a href="#">CVH271KH-SQ</a>	415815	415811	415809	416158	100431	100430	102226	415059
A407CH-3	413627	<a href="#">CVH400KH-SQ</a>	413992	412479	413988	413714	100431	100430	102392 021740-000	100713 009384-000
A2609-1	416266	<a href="#">VHP260KH-3-SQ</a>	-	-	-	-	-	-	-	-
A4076-21	413605	<a href="#">VP400KH-SQ</a>	412300	114300	161088	411424	100431	100430	102392 021740-000	100713 009384-000
A4078-12	412263	<a href="#">VHP430KH-3SQ</a>	412300	114300	161088	411424	100431	100430	102392 021740-000	100713 009384-000
A26908	415509	<a href="#">VHP260KH-3-SQ</a>	-	-	-	415665	-	-	-	-
A40209	166186	<a href="#">VHP370KH-3-SQ</a>	166265	166269	166266	411447	160699 101699	-	100708*	-
A40209-1	413174	<a href="#">VHP370KH-3-SQ</a>	167523	165888	167522	410995	160699 101699	-	100708*	-
B153CH1	415223	<a href="#">CVH150KH</a>	415262	415268	415264	415346	108045	104960	415251	-
B1513CH1	415444	<a href="#">CVH150KH</a>	415557	415268	415554	415564	108045	104960	415251	-
GB170	011360-000	<a href="#">KO7.5KH</a>		018254-000	021825-000	020970-000	092178-006	092724-000	018447-000	-
M81757/9-2	023476-000	M81737/1-6	-	021009-000	023740-000	-	093616-000	-	022297-000	019239-000

Table 10002 - Battery parts list (continued)

\*Power connector assembly 100708 is comprised of procurable components listed in paragraph [BAC102 power connector assembly](#).

ILLUSTRATED PARTS LIST

2-1. BAC102 power connector assembly

Item	P/N (F6177)	Description	Quantity
A	100708	Connector	1
B	165884	. Connector base	1
C	165885	. Gasket	1
D	165881	. Terminal, positive	1
E	165882	. Terminal, negative	1
F	165887	. O-ring	2
G	011614	. Nut, M22x1	2
H	011615	. Nut, M18x1	2
I	160699	. Screw, F/90, M4x8	3
J	101699	. Screw, F/90, M4x12	1
K	102939	. Protector	2

Table 10003 - BAC102 power connector assembly

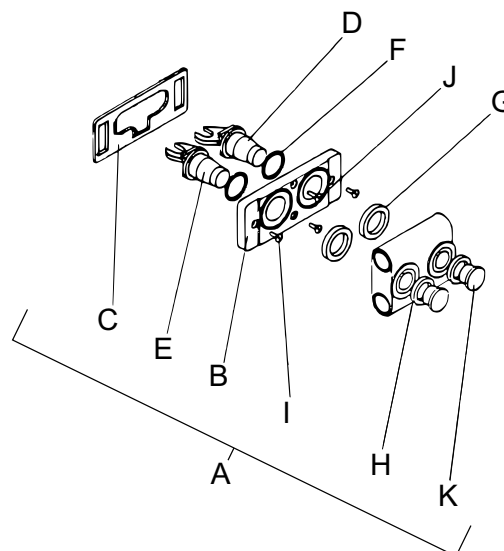

Figure 10002 - BAC102 power connector assembly

3. Inter-cell connections

3-1. Inter-cell connections parts list

Battery	Cell connections	(030) Link	(040) Link	(050) Link	(060) Link	(070) Link	(080) Link	(090) Link
19VO3KHB	<a href="#">VA1901</a>	011949	-	-	-	-	-	-
20VO3KHB	<a href="#">VI2001</a>	011949	414573	-	-	-	-	-
151CH2	<a href="#">VD2002</a>	101279	101229	101279	414480	-	-	-
176CH	<a href="#">VA2003</a>	015737-000	015735-000	015736-000	015734-000	015728-000	-	-
176CH6	<a href="#">VA2002</a>	015737-000	015735-000	015736-000	015734-000	019728-000	016895-000	-
178CH1	<a href="#">VA2002</a>	013678	012944	013633	012943	416504	114735	-
181CH	<a href="#">VG2002</a>	101229	101228	-	-	-	-	-
272CH1	<a href="#">HD2001</a>	012802	014403	114735	-	-	-	-
276CH7	<a href="#">VC2003</a>	101229	100880	101228	101231	057012	101230	-
276CH10	<a href="#">VC2003</a>	014403	012944	012943	014404	057012	014703	-
276CH23	<a href="#">VC2002</a>	014403 015684-000	012944 021090-000	012943 015693-000	014404 015685-000	057012 015682-000	014703 015679-000	114735 015681-000
345CD1	<a href="#">HE2001</a>	012943	013633	013678	014404	413419	415315	415316
405CH3	<a href="#">CA2005</a>	012374	015539	116112	411691	114767	-	-
438CH2	<a href="#">CA2002</a>	015575-000	015577-000	015578-000	015576-000	015926-000	-	-
407CH5	<a href="#">CA2002</a>	012374	015539	015266	411691	114767	-	-
407CH9	<a href="#">CA2002</a>	015575-000	015577-000	015578-000	015926-000	015576-000	-	-
447CH1	<a href="#">CA2002</a>	012374	015539	015266	057014	114767	012374	-
447CH3	<a href="#">CA2002</a>	012374	015539	015266	411691	012374	412421	-
447CH8	<a href="#">CA2002</a>	012374	015539	015266	411691	114767	-	-
505CH3	<a href="#">CA2005</a>	414994	414993	114767	012374	012606	-	-
616	<a href="#">VG2003</a>	101279	410285	-	-	-	-	-
666	<a href="#">CA1903</a>	101279	410708					
1277	<a href="#">CB1901</a>	100516	100517	100518	100519	100520	102256	-
1277-1	<a href="#">CB1901</a>	100516	100517	100518	118096	100520	102256	-

Table 10004 - Links parts list

## ILLUSTRATED PARTS LIST

Battery	Cell connections	(030) Link	(040) Link	(050) Link	(060) Link	(070) Link	(080) Link	(090) Link
1277-3	<a href="#">CB1901</a>	414142	414141	100518	414143	414144	414242	-
1606	<a href="#">VD2002</a>	013678	012943	-	013678	-	-	-
1608	<a href="#">VD2002</a>	013678	012943	-	-	-	-	-
1608-1	<a href="#">VD2002</a>	013678	012943	114735	013678	-	-	-
1656	<a href="#">VA2001</a>	013678	012944	013633	012943	014703	-	-
1656-1	<a href="#">VA2002</a>	013678	012944	013633	012943	014703	114735	-
1656-2	<a href="#">VA2002</a>	012943	012944	013633	013678	014703	-	-
1656-5	<a href="#">VA2002</a>	012943	012944	013633	013678	014703	-	-
1658	<a href="#">VA2001</a>	012943	012944	013633	013678	014703	-	-
1658-2	<a href="#">VA2002</a>	012943	012944	013633	013678	014703	-	-
1666-1	<a href="#">VB2001</a>	012943	014702	166878	114735	-	-	-
1718	<a href="#">VA1001</a>	012943	414453	100874	013678	-	-	-
1756	<a href="#">VA2001</a>	015734-000	015735-000	015736-000	015737-000	019728-000	-	-
2353-1	<a href="#">CB1902</a>	101231	101229	101228	100890	057012	018043	018044
2371	<a href="#">CB2002</a>	101228	101229	101230	101231	057012	100880	101230
2371-1	<a href="#">CB2001</a>	101228	101229	101230	101231	057012	100880	114735
2371-2	<a href="#">CB2001</a>	101228	101229	101230	101231	057012	100880	114735
2371-5	<a href="#">CB2001</a>	101228	101229	101230	101231	057012	100880	114735
2371-6	<a href="#">CB2001</a>	101228	101229	101230	101231	057012	100880	114735
2371-7	<a href="#">CB2003</a>	101228	101229	101230	101231	057012	100880	-
2376	<a href="#">CB2002</a>	101228	101229	101230	101231	057012	100880	101229
2376-1	<a href="#">CB2001</a>	101228	101229	101230	101231	057012	100880	114735
2376-2	<a href="#">CB2001</a>	101228	101229	101230	101231	057012	100880	114735
2376-4	<a href="#">CB2001</a>	101228	101229	101230	101231	057012	100880	101228
2376-7	<a href="#">CB2002</a>	101228	101229	101230	101231	057012	100880	-
2376-8	<a href="#">CB2001</a>	101228	101229	101230	101231	057012	100880	114735
2376-10	<a href="#">CB2001</a>	015679-000	015681-000	015682-000	015683-000	015684-000	015685-000	021090-000
2378	<a href="#">CB2002</a>	101228	101229	101230	101231	057012	100880	-
2386-1	<a href="#">CA2002</a>	005787-005	005787-013	013087-009	012520-000	023803-000	005787-011	-
2500	<a href="#">VD2001</a>	014709	103267	014702	-	-	-	-
2506-1	<a href="#">HB2001</a>	013678	013955	115601	115598	-	-	-
2506-2	<a href="#">HB2002</a>	013678	013955	115601	115598	116060	-	-
2522	<a href="#">VF2001</a>	013955	103459	014702	014404	-	-	-
2708-1	<a href="#">HA2001</a>	012374	165881	165882	-	-	-	-
2708-2	<a href="#">HA2002</a>	012374	165881	165882	114767	-	-	-
2778	<a href="#">CA2001</a>	012374	015539	015266	057014	-	-	-
2778-2	<a href="#">CA2002</a>	012374	015539	116112	057014	114767	012374	-
2778-5	<a href="#">CA2002</a>	012374	015539	166686	057014	166687	-	-
2778-10	<a href="#">CA2002</a>	012374	015539	015266	057014	114767	-	-
2778-15	<a href="#">CA2002</a>	012374	015539	116112	057014	114767	114767	-
2778-18	<a href="#">CA2001</a>	012374	015539	015266	411691	-	-	-

Table 10004 - Links parts list (continued)

## ILLUSTRATED PARTS LIST

Battery	Cell connections	(030) Link	(040) Link	(050) Link	(060) Link	(070) Link	(080) Link	(090) Link
4000A1	<a href="#">HA2001</a>	012374	100079	100080	-	-	-	-
4002	<a href="#">HA2002</a>	012374	100079	100080	-	-	-	-
4006A	<a href="#">HA2001</a>	012374	100079	100080	-	-	-	-
4006A-1	<a href="#">HA2002</a>	012374	100079	100080	-	-	-	-
4008-1	<a href="#">HA2003</a>	012374	100079	100080	114767	-	-	-
4015CH-11	<a href="#">CA2001</a>	015575-000	015577-000	015578-000	015576-000	-	-	-
4017CH-1	<a href="#">CA1901</a>	015575-000	015577-000	015576-000	-	-	-	-
4050A1-1	<a href="#">CA2002</a>	012374	100098	012521	057014	100097	014184	-
4071	<a href="#">CA2001</a>	012374 015575-000	015539 015577-000	015266 015578-000	057014 015576-000	-	-	-
4071-1	<a href="#">CA2002</a>	012374 015575-000	015539 015577-000	015266 015578-000	057014 015576-000	114767	-	-
4071-2	<a href="#">CA2002</a>	012374 015575-000	015539 015577-000	116112 016423-000	057014 015576-000	114767	-	-
4071-3	<a href="#">CA2002</a>	012374 015575-000	015539 015577-000	116112 016423-000	057014 015576-000	114767	-	-
4072	<a href="#">CA2001</a>	012374 015575-000	015539 015577-000	015266 015578-000	057014 015576-000	-	-	-
4076	<a href="#">CA2001</a>	012374 015575-000	015539 015577-000	015266 015578-000	057014 015576-000	-	-	-
4076-1	<a href="#">CA2002</a>	012374 015575-000	015539 015577-000	015266 015578-000	057014 015576-000	114767	012374 015575-000	-
4076-2	<a href="#">CA2002</a>	012374 015575-000	015539 015577-000	015266 015578-000	057014 015576-000	114767	-	-
4076-3	<a href="#">CA2002</a>	012374 015575-000	015539 015577-000	015266 015578-000	057014 015576-000	114767	-	-
4076-9	<a href="#">CA2002</a>	012374	015539	015266	057014	114767	012374	-
4076-11	<a href="#">CA2001</a>	015575-000	015577-000	015578-000	015576-000	-	-	-
4076-12	<a href="#">CA2001</a>	015575-000	015577-000	015578-000	015576-000	-	-	-
4076-13	<a href="#">CA2001</a>	015575-000	015577-000	015578-000	015576-000	-	-	-
4076-15	<a href="#">CA2002</a>	012374 015575-000	015539 015577-000	116112 016423-000	057014 015576-000	114767	-	-
4076-16	<a href="#">CA2002</a>	012374	015539	015266	057014	114767	-	-
4076-17	<a href="#">CA2001</a>	012374	015539	015266	411691	-	-	-
4077	<a href="#">CA1902</a>	102298	102299	102300	102301	-	-	-
4078	<a href="#">CA2001</a>	012374	015539	015266	057014	-	-	-
4078-1	<a href="#">CA2002</a>	012374	015539	015266	057014	114767	-	-
4078-5	<a href="#">CA2002</a>	012374	015539	116112	057014	114767	-	-
4078-6	<a href="#">CA2001</a>	015575-000	015577-000	015578-000	015576-000	-	-	-
4078-9	<a href="#">CA2002</a>	015575-000	015577-000	016423-000	015576-000	015926-000	-	-
4078-10	<a href="#">CA2002</a>	015575-000	015577-000	015578-000	015576-000	015926-000	-	-
4078-11	<a href="#">CA2004</a>	012374	015539	116112	411691	114767	413051	-
4078-13	<a href="#">CA2001</a>	012374	015539	015266	057014	-	-	-
4078-16	<a href="#">CA2002</a>	012374	015539	116112	411691	114767	-	-
4078-18	<a href="#">CA2002</a>	012374	015539	116112	411691	114767	-	-

Table 10004 - Links parts list (continued)

## ILLUSTRATED PARTS LIST

Battery	Cell connections	(030) Link	(040) Link	(050) Link	(060) Link	(070) Link	(080) Link	(090) Link
4078-19	<a href="#">CA2002</a>	015575-000	015577-000	016423-000	015576-000	015926-000	015575-000	-
4079-19	<a href="#">CA2002</a>	015575-000	015577-000	016423-000	015576-000	015926-000	-	-
4078-21	<a href="#">CA2001</a>	012374	015539	015266	411691	-	-	-
4079	<a href="#">CA2001</a>	012374	015536	015266	057014	-	-	-
4079-1	<a href="#">CA2002</a>	012374	015539	015266	057214	102393	-	-
4079-6	<a href="#">CA2002</a>	012374	015539	015266	411691	114767	-	-
4079-9	<a href="#">CA2001</a>	012374	015539	015266	411691	-	-	-
4078-10	<a href="#">CA2001</a>	015575-000	015577-000,	016423-000,	015576-000,	015926-000	-	-
4080	<a href="#">CA2001</a>	014184	015539	012521	057014	012374	-	-
4317CH1	<a href="#">CA2002</a>	015575-000	015577-000	016423-000	015576-000	015926-000	-	-
4417CH14	<a href="#">CA2001</a>	015575-000	015577-000	015578-000	015576-000	-	-	-
4076-13	<a href="#">CA2001</a>	015575-000	015577-000	015578-000	015576-000	-	-	-
5035CH4	<a href="#">CA2009</a>	012374	012606	416630	414993	414994	015539	-
5512CH1	<a href="#">VA1101</a>	022002-000	022001-000	022003-000	-	-	-	-
6206	<a href="#">VD2003</a>	101279	-	-	-	-	-	-
12277-2	<a href="#">CB1901</a>	017342-001	017342-002	017343-000	017342-003	017342-004	017342-003	-
16106-1	<a href="#">VD2002</a>	013678	012943	114735	-	-	-	-
16108-1	<a href="#">VD2002</a>	013678	012943	114735	-	-	-	-
16156		015735-000	015734-000	015737-000	017303-000	019728-000	-	-
16156-1	<a href="#">HC2001</a>	012802	013678	014704	014404	012943	114735	-
16258	<a href="#">VA2002</a>	013678	012944	013633	012943	014703	114735	-
23171-4	<a href="#">CB2002</a>	101228	101229	101230	101231	057012	100880	-
23175	<a href="#">CB1903</a>	101228	101229	101230	101231	057012	100880	114735 [95] 103489
23176	<a href="#">CB2001</a>	101228 015681-000	101229 015685-000	101230 015679-000	101231 021090-000	057012 015684-000	100880	114735
23378	<a href="#">CB2002</a>	101228	101229	101230	101231	057012	100880	-
23476	<a href="#">CB2001</a>	101228	101229	101230	101231	057012	100880	114735
23478	<a href="#">CB2002</a>	101228	101229	101230	101231	057012	100880	114735
23491	<a href="#">VC2001</a>	101229	101230	101228	057012	105623	114735	-
23491-3	<a href="#">VC2001</a>	101229	101230	101228	057012	105623	114735	-
23491-4	<a href="#">VC2001</a>	057012	100880	101228	101229	101230	105623	413243
23498-1	<a href="#">VC2001</a>	101229	101230	101228	057012	105623	114735	-
23576-1	<a href="#">CB2002</a>	015676-000	015681-000	-	015683-000	015684-000	015685-000	015682-000
23576-2	<a href="#">CB2003</a>	015679-000	015681-000	015682-000	015683-000	015684-000	015685-000	019746-000
23676-2	<a href="#">VH2001</a>	015681-000	015679-000	019277-000	019746-000	-	-	-
23678-1	<a href="#">CB2002</a>	101228	101229	101230	101231	057012	100880	114735
23678-2	<a href="#">CB2002</a>	101228	101229	101230	101231	057012	100880	-
23678-3	<a href="#">CB2001</a>	101228	101229	101230	101231	057012	100880	114735
25106	<a href="#">HB2001</a>	013678	013955	115601	115598	115948	115949	-
25106-2	<a href="#">HB2002</a>	013678	013955	115601	115598	116060	115948	115949
26108-3	<a href="#">VG2001</a>	101230	101228	413894	-	-	-	-

Table 10004 - Links parts list (continued)

## ILLUSTRATED PARTS LIST

Battery	Cell connections	(030) Link	(040) Link	(050) Link	(060) Link	(070) Link	(080) Link	(090) Link
26108-4	<a href="#">VG2001</a>	101230	101228	413894	-	-	-	-
26108-5	<a href="#">VG2001</a>	101230	101228	413894	-	-	-	-
26108-7	<a href="#">VG2001</a>	101230	101228	413894	-	-	-	-
26308-1		101228	101230	114735	100784	-	-	-
26408-1	<a href="#">VG2001</a>	114735	101228	101229	-	-	-	-
26508	<a href="#">VG2002</a>	101228	101229	414847	414848	-	-	-
26608	<a href="#">VG2002</a>	101228	101229	414847	414848	-	-	-
26708	<a href="#">VG2002</a>	101228	101229	414847	414848	-	-	-
27278-2	<a href="#">CA2002</a>	012374	015539	116112	057014	114767	-	-
27478	<a href="#">CA2008</a>	012374	015266	015539	411691	114767	-	-
27578-2	<a href="#">CA2002</a>	015575-000	015577-000	016423-000	015926-000	015575-000	-	-
40042	<a href="#">VA1001</a>	015266	012606	012374	411017	015545	057014	-
40100A	<a href="#">HA2002</a>	012374	116127	116428	-	-	-	-
40100-1	<a href="#">HA2002</a>	012374	116427	116428	114767	-	-	-
40142	<a href="#">VA1101</a>	012374	015266	012606	411017	-	-	-
40143	<a href="#">VA1101</a>	014184	012374	015539	057014	-	-	-
40152	<a href="#">VA1101</a>	014184	012374	015539	057014	-	-	-
40178	<a href="#">CA2001</a>	012374	057014	015539	015266	-	-	-
40178-7	<a href="#">CA2004</a>	012374	412610	015539	412598	114767	412599	-
40178-21	<a href="#">CA2001</a>	012374	015539	015266	411691	-	-	-
40200	<a href="#">HA2001</a>	012374	-	-	-	-	-	-
40200-1	<a href="#">HA2004</a>	012374	114767	-	-	-	-	-
40206-2	<a href="#">HA2002</a>	012374	165881	165882	114767	-	-	-
40208	<a href="#">HA2001</a>	012374	165881	165882	-	-	-	-
40208-1	<a href="#">HA2001</a>	012374	165881	165882	-	-	-	-
40208-2	<a href="#">HA2002</a>	012374	165881	165882	114767	-	-	-
40208-4	<a href="#">HA2002</a>	012374	165881	165882	114767	-	-	-
40208-5	<a href="#">HA2005</a>	012374	165881	165882	114767	-	-	-
40208-7	<a href="#">HA2004</a>	012374	165881	165882	114767	-	-	-
40209-2	<a href="#">HA2001</a>	012374	165881	165882	-	-	-	-
40253		015576-000	015575-000	015579-000	-	-	-	-
40278-2	<a href="#">CA2002</a>	012374	015539	116112	057014	114767	-	-
40278-14	<a href="#">CA2001</a>	012374	015539	015266	411691	-	-	-
40300	<a href="#">HA2002</a>	012944	411999	412000	-	-	-	-
40306	<a href="#">HA2002</a>	012374	100079	100080	-	-	-	-
40342	<a href="#">VA1002</a>	012374	057014	012374	-	-	-	-
40371	<a href="#">CA2001</a>	012374	015539	015266	057014	-	-	-
40408	<a href="#">HA2002</a>	012374	165881	165882	114767	-	-	-
40508-1	<a href="#">VD2002</a>	012374	108172	413187	012374	-	-	-
40576	<a href="#">CA2001</a>	012374 015575-000	015539 015577-000	015266 015578-000	057014 015576-000	-	-	-
40576-3	<a href="#">CA2001</a>	015575-000	015577-000	015578-000	015576-000	-	-	-

Table 10004 - Links parts list (continued)

## ILLUSTRATED PARTS LIST

Battery	Cell connections	(030) Link	(040) Link	(050) Link	(060) Link	(070) Link	(080) Link	(090) Link
40576-14	<a href="#">CA2001</a>	015575-000	015577-000	015578-000	015576-000	-	-	-
40678-4	<a href="#">CA2002</a>	015575-000	015577-000	023488-000	023489-000	015576-000	-	-
40776	<a href="#">CA2002</a>	015575-000	015577-000	015578-000	015576-000	015926-000	-	-
40778-11	<a href="#">CA2004</a>	012374	411691	015539	116112	114767	413051	-
401076	<a href="#">CA2002</a>	015575-000	015577-000	015578-000	015576-000	015926-000	-	-
A275CH1	<a href="#">CA2006</a>	416216	413983	014704	014703	014404	014403	90 : 012943 91 : 411730
A407CH-3	<a href="#">CA2002</a>	015539	015539	116112	411691	012374	-	-
A2609-1	<a href="#">VD2003</a>	012943	014403	413983	-	-	-	-
A4076-21	<a href="#">CA2002</a>	012374	015539	116112	057014	114767	012374	-
A4078-12	<a href="#">CA2002</a>	012374	015539	116112	057014	114767	-	-
A26908	<a href="#">VE2001</a>	415569	415568	014403	012943	414917	-	-
A40209	<a href="#">HA2001</a>	012374	165881	165882	-	-	-	-
A40209-1	<a href="#">HA2002</a>	012374	165881	165882	114767	-	-	-
GB170	<a href="#">VA1902</a>	007812-001	007812-003	-	-	-	-	-
M81757/9-2		017225-001	017225-002	014368-004	-	-	-	-

Table 10004 - Links parts list (continued)

ILLUSTRATED PARTS LIST

3-2. Battery connection layouts

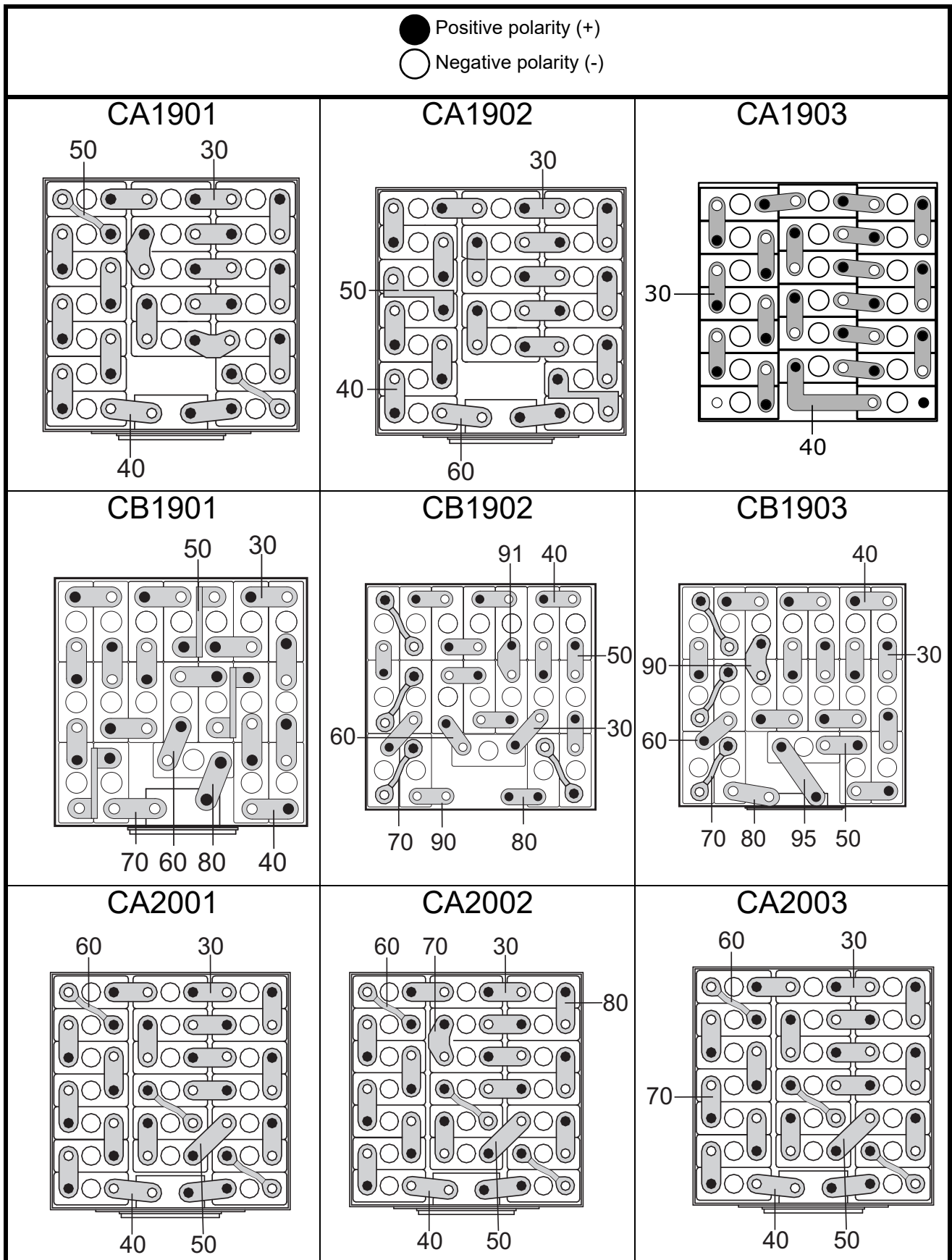

Table 10005 - Battery connection layouts



● Positive polarity (+)  
○ Negative polarity (-)

<p><b>CA2004</b></p>	<p><b>CA2005</b></p>	<p><b>CA2006</b></p>
<p><b>CA2007</b></p>	<p><b>CA2008</b></p>	<p><b>CA2009</b></p>
<p><b>CB2001</b></p>	<p><b>CB2002</b></p>	<p><b>CB2003</b></p>

Table 10005 - Battery connection layouts (continued)

ILLUSTRATED PARTS LIST

<p>● Positive polarity (+) ○ Negative polarity (-)</p>		
<p><b>HA2001</b></p>	<p><b>HA2002</b></p> <p>60</p>	<p><b>HA2003</b></p>
<p><b>HA2004</b></p> <p>60</p>	<p><b>HA2005</b></p> <p>60</p>	
<p><b>HB2001</b></p> <p>60 40</p>	<p><b>HB2002</b></p> <p>60 40 70</p>	
<p><b>HC2001</b></p> <p>30 40</p> <p>80</p>	<p><b>HD2001</b></p> <p>30</p>	<p><b>HE2001</b></p> <p>50</p>

Table 10005 - Battery connection layouts (continued)

● Positive polarity (+)  
○ Negative polarity (-)

<p>VA1001</p>	<p>VA1002</p>	<p>VA1101</p>
<p>VA1901</p>	<p>VA1902</p>	
<p>VA2001</p>	<p>VA2002</p>	<p>VA2003</p>

Table 10005 - Battery connection layouts (continued)

ILLUSTRATED PARTS LIST

<p>● Positive polarity (+) ○ Negative polarity (-)</p>		
<p><b>VB1001</b></p>	<p><b>VB1101</b></p>	<p><b>VB2001</b></p>
<p><b>VC2001</b></p>	<p><b>VC2002</b></p>	<p><b>VC2003</b></p>
<p><b>VD2001</b></p>	<p><b>VD2002</b></p>	<p><b>VD2003</b></p>

Table 10005 - Battery connection layouts (continued)

<p>● Positive polarity (+) ○ Negative polarity (-)</p>		
<p><b>VE2001</b></p>	<p><b>VF2001</b></p>	
<p><b>VG2001</b></p>	<p><b>VG2002</b></p>	<p><b>VG2003</b></p>
<p><b>VH2001</b></p>	<p><b>VI2001</b></p>	

Table 10005 - Battery connection layouts (continued)

## ILLUSTRATED PARTS LIST

## 4. Cell assembly parts list

Cell type	(100) Cell P/N	(110)/(115) Nut upper/ lower	(120) Washer, Spring	(130) Washer, +polarity	(140) Washer, -polarity	(150) Washer, flat	(160) Vent-valve + O-ring
CVD34KH	413481	413445	100111	100695	100696	100479	415219
CVH150KH	414400	411810 (upper) 413445 (lower)	100111	100695	100696	100479	415215
CVH170KA	025852-000 416492	015995-000	018124-000	-	-	015999-000	458788 023641-000
CVH180KH	414244 024600-000	411810 015995-000	100111	100695	100696	100479	415215
CVH180KH-SQ	413105	411810	100111	100695	100696	100479	415221
CVH271KH	415227	062000 015995-000	100111 018124-000	100695	100696	100479	415215
CVH271KH-SQ	415230	062000	100111	100695	100696	100479	
CVH400KA	413597 023413-000	062007 015579-000	100094 022228-000	100694 023388-001	100693 023388-002	100078 021870-000	413600 023619-000
CVH400KH-SQ	413598	062007	100094	100694	100693	100078	413618
CVH430KA	025853-000	015579-000	022228-000	023388-001	023388-002	021870-000	023619-000
CVH441KH	414470	062007	100094	100694	100693	100078	415213 015957-000
CVH441KH-SQ	414491	062007	100094	100694	100693	100078	415217
CVH500KA	414984	062007	100094	100694	100693	100078	415213 015957-000
CVH531KA							
CVH550KA	025866-000	093707-000	092456-000	-	-	092488-000	023619-000
HVO1.1							
KO7.5KH	019872-000	090312-000	091179-014				
VHP170KH-3	166129	062000	100111	100695	100696	100479	415219
VHP170KH-3-SQ	412827	062023	100110	100695	100696	100479	415220
VHP230KA3	410406	062007	100094	100694	-	100078	023400-000 415218
VHP260KH-3	166300	062000	100111	100695	100696	100479	415219
VHP260KH-3-SQ	410232						
VHP270KH-3	165949	062007	100094	100694	100693	100078	023400-000 415218
VHP270KH-3-SQ	410155	062007	100094	100694	100693	100078	415217
VHP370KA-3	165823	062007	100094	100694	100693	100078	023400-000 415218
VHP370KH-3-SQ	166127	062007	100094	100694	100693	100078	415217
VHP430KH-3	165797 019858-000	062007 015579-000	100094 022228-000	100694 023388-001	100693 023388-002	100078 021870-000	023400-000 415218
VHP430KH-3SQ	411288	062007	100094	100694	100693	100078	415217
VHP450KA-3	411480	062007	100094	100694	100693	100078	415213 015957-000
VHP450KH-1	023065-000	015579-000	021871-000	023388-001	023388-002	021870-000	015957-000

Table 10006 - Cell assembly parts list

## ILLUSTRATED PARTS LIST

Cell type	(100) Cell P/N	(110)/(115) Nut upper/ lower	(120) Washer, Spring	(130) Washer, +polarity	(140) Washer, -polarity	(150) Washer, flat	(160) Vent-valve + O-ring
VO3KHB	102875	062005	100132	102158	102159	-	102880 + 100656
VO16KH	063409	062000	100111	100973	013998	013999	415215
VO23KH	063410 016726-000	062000 015995-000	100111 018124-000	100695 023935-001	100696 023935-002	100479 015999-000	415215 015990-000
VO23KH-SQ	410537	062000	100111	100695	100696	100479	415220
VO25KA	103247	062000	100111	100695	100696	100479	415215
VO25KA-C	412948	062000	100111	100695	-	100479	415215
VO40KH	063428 016650-000	062007 015579-000	100094 022228-000	100694 023388-001	100693 023388-002	100078 021870-000	415213 015957-000
VO40KH-3	412462	062023	100111	100695	100696	100479	
VO40KH-C	412933	062007	100094	100694	100693	100078	415213 015957-000
VO80KH	102555	062013	011649	100325	100326	412269	
VOEC40KH	411366	411362	100094	100694	-	100078	
VP120KHB	018910-000	009772-000	091179-035	-	-	008021-002	093625-000
VP120KH-MS	063424		102883	-	-	-	
VP160KH	063417	062023	100111	100695	100696	100479	415215
VP160KH-SQ	410379	062000	100111				415220
VP160KM	161144	062003	100111	100695	100696	100479	415215
VP160KM-SQ	167590	062003	100111	100695	100696	100479	415220
VP170KH	163937	062002	100111	100695	100696	100479	415215
VP200KHB	459842	062000	100111	100695	100696	100479	093625-000
VP230KH	063415 015698-000	062000 015995-000	100111 018124-000	023935-001	023935-002	100479 015999-000	415215
VP250KH	063413	062023	100111	100695	100696	100479	415215
VP340KA	021684-000	015579-000	022228-000	023388-001	023388-002	021870-000	415213 015957-000
VP380KH	021685-000	015579-000	022228-000	023388-001	023388-002	021870-000	415213 015957-000
VP400KH*	063412 015602-000	062007 015579-000	100094 022228-000	100694 023388-001	100693 023388-002	100078 021870-000	415213 015957-000
VP400KH-AC	017360-000	015579-000	022228-000	023388-001	023388-002	021870-000	017621-000
VP400KH-MS	410583	083003	078011	-	-	-	
VP400KH-SQ	166927	062007	100111	100694	100693	100094	415217
VP65K	100742	100736	100111	-	-	100735	415214
VXP310KH	412960	062007	100094	100694	-	100094	415218 023400-000

Table 10006 - Cell assembly parts list (continued)

\*Components of VP400KH cell assemblies purchased under cage code F6177 are not interchangeable with components of cell assemblies purchased under cage code 09052.

## ILLUSTRATED PARTS LIST

### 5. Sensor connector covers

Refer to the table [Sensor connector cover sizing chart](#) to find a military standard reference for a cover that fits the battery's sensor connector. To ensure proper retention of the sensor connector cover on the sensor connector, the diameter of the sensor connector cover should be slightly smaller than the outermost diameter of the sensor connector.

**NOTE: Saft does not sell these parts. They must be procured from an external supplier of the military standard reference.**

Military standard reference	Diameter (mm)	Diameter (inches)
MS93076-8Y	10.5	0.413
MS93076-8R	12.2	0.480
MS93076-10Y	13.5	0.530
MS93076-10R	15.4	0.605
MS93076-12Y	16.6	0.655
MS93076-12R	18.3	0.720
MS93076-14Y	19.9	0.785
MS93076-14R	21.6	0.850
MS93076-16Y	22.7	0.893
MS93076-16R	24.7	0.973
MS93076-18Y	26.1	1.028
MS93076-18R	27.8	1.093
MS93076-20Y	29.2	1.150
MS93076-20R	31.3	1.231
MS93076-22Y	32.3	1.270
MS93076-22R	34.0	1.340
MS93076-24Y	35.3	1.390
MS93076-24R	37.2	1.463

Table 10007 - Sensor connector cover sizing chart



## STORAGE (INCLUDING TRANSPORTATION)

### 1. Introduction

#### 1-1. General

This document describes different methods of storage conditions recommended for a battery which has been cleaned and serviced and is not immediately placed in service on-board an aircraft.

Proper storage conditions and packaging makes sure that the equipment is protected against environmental damages.

#### 1-2. Storage room

Keep the batteries and spares in a dry and clean room isolated from detrimental agents such as: dirt, dust, dampness, vibration, and corrosive atmosphere.

Lead-acid batteries must not be stored in the same room as Saft Ni-Cd batteries.

#### 1-3. Climatic conditions

The recommended temperature range is  $+20\text{ °C} \pm 15\text{ °C}$  ( $+68\text{ °F} \pm 27\text{ °F}$ ).

Pressure 750 to 1060 hPa (22.15 to 31.3 in.Hg).

Relative humidity  $< 85\%$ .

### 2. Storage

#### 2-1. Inactive long-term storage

##### 2-1-1. Procedure

Before placing a battery into inactive long-term storage, the battery must successfully complete [Regular check](#) or [General overhaul](#) and be in a discharged condition (refer to [Residual discharge](#) and [Cell shorting](#)). There is no need of maintenance operation during the storage period. It is not necessary to short circuit the battery. No revalidation is required during the storage.

**NOTE: If [Climatic conditions](#) are met and the packaging protects the battery from mechanical damages, environmental contaminants (i.e.: dirt, dust, vibrations, or corrosive atmosphere), and is airtight, then a 10 year storage period is allowed (if not airtight, a 2 year storage period is allowed).**

The batteries are stored in a normal vertical position as described in paragraphs [Storage room](#) and [Climatic conditions](#).

##### 2-1-2. Action at the end of long-term storage

For batteries under long-term storage and before installation of the battery into the aircraft for service:

- If storage time is less than or equal to 12 months, then do [Visual inspection](#), [Insulation check](#), [Nut tightness](#), [Charge](#), [Adjust electrolyte level](#), and repeat [Insulation check](#).
- If storage time is over 12 months do [Charge](#) followed by [Regular check](#).

#### 2-2. Inactive standby storage

##### 2-2-1. Scope

The inactive standby storage allows the battery to be stored in a “ready to be installed on the aircraft” condition.

##### 2-2-2. Procedure

**CAUTION: IF THE FOLLOWING CONDITIONS ARE NOT MET, THERE IS A RISK OF PLACING A BATTERY ON BOARD AN AIRCRAFT THAT DOES NOT MEET THE EMERGENCY REQUIREMENTS.**

**NOTE: The temperature is the average temperature during the storage period.**

**NOTE: If the battery was previously stored at a temperature below the ambient temperature, condensation may occur. Before installing do [Insulation check](#).**

Maintain the battery per CMM procedures. Store the battery fully charged (refer to [Charge](#)) in a dedicated room (refer to [Storage room](#) and [Climatic conditions](#)) to be able to be installed in the aircraft without further check any time during an inactive standby storage period. The battery may be kept in inactive standby storage for a period of 90 days maximum corresponding to 80 % available capacity (refer to figure [15001 - Standby storage period](#)).

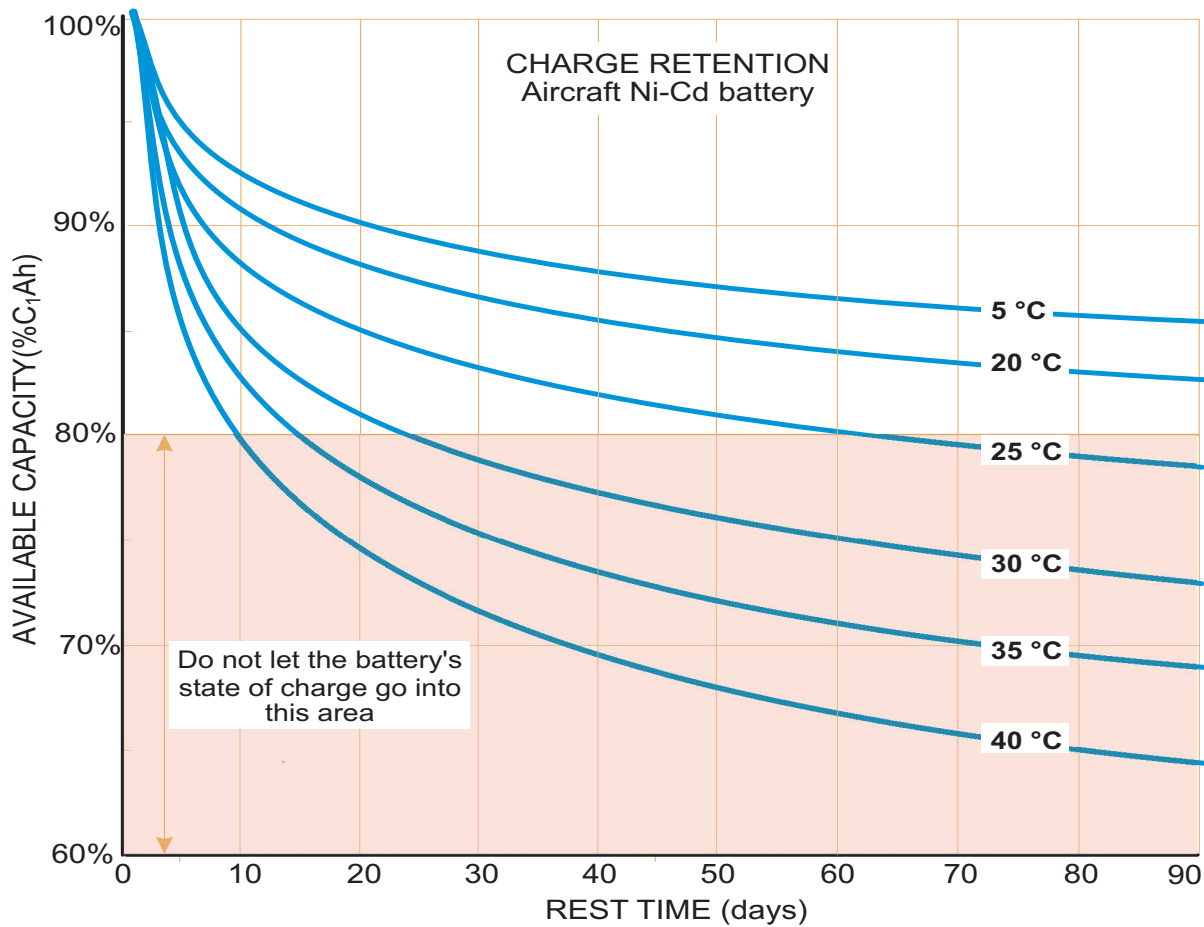

Figure 15001 - Standby storage period

**2-2-2-1. Definitions**

- The [inactive standby storage](#) period is a maximum 90 days (3 months) for average room temperature < +23 °C (+73.4 °F)
- Total standby storage duration is 9 standby storage periods or 810 days (27 months)

**2-2-2-2. Examples of standby storage period**

- 24 days at an average room temperature of +30 °C (+86 °F)
- 60 days at an average room temperature of +25 °C (+77 °F)

**2-2-3. Refresh charge**

The [inactive standby storage](#) period can be prolonged by applying refresh charge (at the end of the period). The refresh charge is defined as a short charge at 0.1C<sub>1</sub>A, 0.5C<sub>1</sub>A, or 1C<sub>1</sub>A until the voltage reaches the values given in the Table [15002 - Inactive standby storage](#) below.

CHARGE rate	VOLTAGE (end of refresh charge)
0.1 C <sub>1</sub> A	1.50 V x number of cells
0.5 C <sub>1</sub> A	1.55 V x number of cells
1.0 C <sub>1</sub> A	1.57 V x number of cells

Table 15001 - Charge rate for refresh charge

The battery can receive the refresh charge two (2) times maximum during each standby storage period. The time necessary to reach the required voltage should be very short. **Do not overcharge at 0.1C<sub>1</sub>A for 4 hours.**

**2-2-4. Action at the end of standby storage periods (refer to figure [15002 - Inactive standby storage](#))**

**NOTE: During any standby storage periods the battery is serviceable.**

STORAGE (INCLUDING TRANSPORTATION)

**2-2-4-1. At the end of standby storage period 1, 2, 4, 5, 7, or period 8**

- Do a [Refresh charge](#) and continue 1 more standby storage period
- Or install the serviceable battery into the aircraft without any further maintenance
- Or place the battery into [Inactive long-term storage](#) refer to the procedure

**2-2-4-2. At the end of standby storage period 3 and period 6**

- Install the serviceable battery into the aircraft without any further maintenance
- Or continue standby storage:
  - if the temperature is  $\leq +30\text{ }^{\circ}\text{C}$  ( $+86\text{ }^{\circ}\text{F}$ ), do [Insulation check](#) + [Residual discharge](#) + [Charge](#) + [Adjust electrolyte level](#) + [Insulation check](#) to continue [Inactive standby storage](#)
  - if the temperature is  $> +30\text{ }^{\circ}\text{C}$  ( $+86\text{ }^{\circ}\text{F}$ ) then do a [Regular check](#) to continue [Inactive standby storage](#)
- Or place the battery into [Inactive long-term storage](#)

**2-2-4-3. At the end of standby storage period 9**

- Install the serviceable battery into the aircraft without any further maintenance
- Or do a [Regular check](#) and place the battery into [Inactive long-term storage](#)

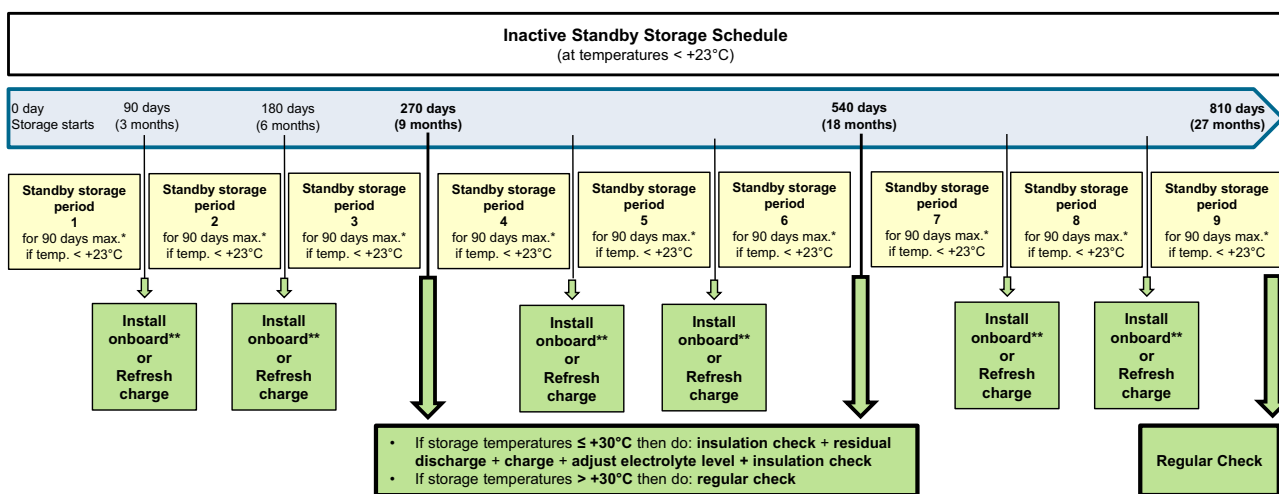

\* If temperatures are  $\geq +23^{\circ}\text{C}$  standby storage periods will be shorter, refer to Figure 15001  
 \*\* The battery can be installed on board the aircraft at any time during the standby storage period

Figure 15002 - Inactive standby storage

**2-2-4-4. Example (figure 15002 - Inactive standby storage)**

**NOTE: Standby storage period is shorter if the temperature is higher; refer to figure 15001 - Standby storage period to adjust the standby storage period duration based on average storage room temperature.**

- The initial standby storage period @  $+20\text{ }^{\circ}\text{C}$  ( $+77\text{ }^{\circ}\text{F}$ ) of a fully charged battery is 90 days (3 months) maximum without any other required operations the capacity will remain over 80 % state of charge
- After 90 days (3 months) of storage @  $+20\text{ }^{\circ}\text{C}$  ( $+77\text{ }^{\circ}\text{F}$ ), 1st [Refresh charge](#). An additional 90 days (3 months) of storage can then be added for a total duration of 180 days (6 months)
- After 180 days (6 months) of storage @  $+20\text{ }^{\circ}\text{C}$  ( $+77\text{ }^{\circ}\text{F}$ ), 2nd [Refresh charge](#). An additional 90 days (3 months) of storage can then be added for a total duration of 270 days (9 months)
- At the end of standby storage period of 90 days (3 months) or 180 days (6 months) either:
  - Do a [Refresh charge](#) to continue 1 more standby storage period
  - Or install the serviceable battery into the aircraft without any further maintenance
  - Or place the battery into [Inactive long-term storage](#)
- At the end of standby storage period of 270 days (9 months) or 540 days (18 months) either:
  - Install the serviceable battery into the aircraft without any further maintenance
  - Or continue standby storage:
    - If the temperature is  $\leq +30\text{ }^{\circ}\text{C}$  ( $+86\text{ }^{\circ}\text{F}$ ) do [Insulation check](#) + [Residual discharge](#) + [Charge](#) + [Adjust electrolyte level](#) + [Insulation check](#) to continue [Inactive standby storage](#)
    - If the temperature is  $> +30\text{ }^{\circ}\text{C}$  ( $+86\text{ }^{\circ}\text{F}$ ) then do a [Regular check](#) to continue standby storage
  - Or place the battery into [Inactive long-term storage](#)
- At the end of standby storage period 810 days (27 months):
  - Install the serviceable battery into the aircraft without any further maintenance
  - Or do a [Regular check](#) and place the battery into [Inactive long-term storage](#)

### 3. Storage of spare parts

#### 3-1. Spare cell assemblies

Spare cells must be stored in a vertical upright position, filled, and discharged condition (electrolyte levels are not visible in discharged cells). It is not necessary to short circuit the cells. The vent-valves must be installed. The storage conditions are the same as those given in paragraph [Inactive long-term storage](#). No maintenance operation is needed during storage. Before installation in a battery, cells must be visually inspected for damage or leakage and cleaned and maintained as necessary in accordance with [Visual inspection](#).

#### 3-2. Spare O-rings, gaskets, and vent-valves assemblies

##### 3-2-1. O-rings and gaskets

Six (6) years of storage period starts from the date of manufacture unless otherwise specified on the packaging. The O-rings and gaskets should be protected from exposure to the air, light, and high humidity < 85 %. Storage life depends on temperature. It is recommended to store the parts in a cool area < +25 °C (+77 °F). Above +35 °C (+95 °F), storage life is reduced to 5 years. Before use the O-rings or gaskets it must be inspected. In case of visible signs of damage, distortion, or deterioration, the part must be discarded.

##### 3-2-2. Vent-valves with O-rings

Six (6) years of storage period starts from the date of manufacture unless otherwise specified on the packaging. The vent-valves and O-rings should be protected from exposure of air, light and high humidity (< 85 %). Storage life depends on temperature. It is recommended to store the parts in a sealed container (non-PVC) in a cool area < +25 °C (+77 °F). Above +35 °C (+95 °F), storage life is reduced to 5 years. Before use the vent-valves and O-rings it must be inspected. In case of visible signs of damage, deformation, or deterioration, the vent-valve and O-ring must be discarded.

##### 3-2-3. Other spares parts

Other spare parts protected from external contamination (i.e. dirt, dust, dampness, vibration, corrosive atmosphere) and high humidity (> 85 %), may be stored for unlimited periods. Before use, parts must be inspected. Parts showing any visible signs of damage, distortions, or deteriorations must be discarded.

### 4. Transportation procedure

The battery is normally discharged before packing. If it is necessary to transport a charged battery, make sure that the output terminals are protected against short circuit.

The battery should be packed vertically in its original container. If the original container is not available, the international and/or local packaging regulations applicable to the mode of transport and destination must be followed.

According to the IATA / IMDG dangerous goods regulations, Saft ships all existing Ni-Cd batteries or cells for aircraft under the classification UN2795 (wet, filled with alkali).



---

NOTES

A series of horizontal dashed lines for taking notes.

