

TITLE

STABILIZERS - HORIZONTAL FASTENER REPLACEMENT

EFFECTIVITY

MODEL	SERIAL NUMBERS
B200GT	BY-434 thru BY-444
B300	FL-1301 thru FL-1309
B300C	FM-108, FM-109

REASON

Magnetic fasteners might have been installed in the left or right horizontal stabilizers, which might cause interference with the left or right flux detector unit.

DESCRIPTION

This service document provides parts and instructions to inspect the trailing edge fasteners and if required replace with non-magnetic fasteners.

COMPLIANCE

RECOMMENDED. This service document should be accomplished at a scheduled maintenance period or inspection.

A service document published by Textron Aviation may be recorded as *completed* in an aircraft log only when the following requirements are satisfied:

- 1) The mechanic must complete all of the instructions in the service document, including the intent therein.
- 2) The mechanic must correctly use and install all applicable parts supplied with the service document kit. Only with written authorization from Textron Aviation can substitute parts or rebuilt parts be used to replace new parts.
- 3) The mechanic or airplane owner must use the technical data in the service document only as approved and published.
- 4) The mechanic or airplane owner must apply the information in the service document only to aircraft serial numbers identified in the *Effectivity* section of the document.
- 5) The mechanic or airplane owner must use maintenance practices that are identified as acceptable standard practices in the aviation industry and governmental regulations.

No individual or corporate organization other than Textron Aviation is authorized to make or apply any changes to a Textron Aviation-issued service document or flight manual supplement without prior written consent from Textron Aviation.

Textron Aviation is not responsible for the quality of maintenance performed to comply with this document, unless the maintenance is accomplished at a Textron Aviation-owned Service Center.

CONSUMABLE MATERIAL

You must use the consumable materials that follow, or their equivalent, to complete this service document.

October 17, 2023

MTL-55-02
Page 1 of 6

Textron Aviation Customer Service, P.O. Box 7706, Wichita, KS 67277, U.S.A. 1-316-517-5800

This document contains technical data and is subject to U.S. export regulations. This information has been exported from the United States in accordance with export administration regulations. Diversion contrary to U.S. law is prohibited. ECCN: 9E991

NAME	NUMBER	MANUFACTURER	USE
Color Chemical Film Treatment	U074093 (Alodine 1132 Touch n Prep)	Textron Aviation Parts Distribution 7121 Southwest Boulevard Wichita, KS 67215	To prepare bare aluminum surface for intermediate primer.
Corrosion Resistant Epoxy Primer	K000574 (2oz kit)	Textron Aviation Parts Distribution 7121 Southwest Boulevard Wichita, KS 67215	Touch up primer kit.

TOOLING

No specialized tooling is required to complete this service document.

REFERENCES

Super King Air B200GT/B200CGT Fusion Maintenance Manual

Super King Air B300/B300C Fusion Maintenance Manual

King Air Structural Inspection and Repair Manual

PUBLICATIONS AFFECTED

None

ACCOMPLISHMENT INSTRUCTIONS

1. Prepare the airplane for maintenance.
 - A. Make sure that the airplane is electrically grounded.
 - B. Make sure that all switches are in the OFF/NORM position.
 - C. Disconnect electrical power from the airplane.
 - (1) Disconnect external electrical power.
 - (2) Disconnect the main airplane battery.
 - D. Attach maintenance warning tags to the battery and external power receptacle that have **"DO NOT CONNECT ELECTRICAL POWER - MAINTENANCE IN PROGRESS"** written on them.
2. (Refer to Figure 1, Sheet 1.) Using a magnet, do an inspection of the fasteners installed on the left upper horizontal stabilizer surface between HSS 35.00 to HSS 74.00 and on the trail edge of left horizontal stabilizer upper surface between HSS 35.00 and HSS 66.00. (Refer to the applicable Maintenance Manual, Chapter 6, Airplane Stations - Description and Operation.)

NOTE: The highlighted red areas of Figure 1, Sheet 1 located on the upper surfaces of the left and right horizontal stabilizers are the areas that need to be inspected with a magnet.

- A. If all the fasteners are non-magnetic, then go to Step 4.
 - B. If any of the fasteners are magnetic between HSS 35.00 and HSS 74.00 on the upper surface and between HSS 35.00 and HSS 66.00 on the trailing edge of the left horizontal stabilizer, go to Step 3.
3. (Refer to Figure 1, Sheet 2.) Replace any of the magnetic fasteners as follows:
 - A. For magnetic fasteners on the upper surface of the left horizontal stabilizer between HSS 35.00 and HSS 74.00 do as follows:
 - (1) Remove the access panels 352EBR, 352DBR, 352CBR as required from the left horizontal stabilizer. (Refer to the applicable Maintenance Manual, Chapter 6, Airplane Access Panels - Description and Operation.)

NOTE: If the fasteners needs to be removed from the right hand stabilizer, remove the 351DBL, 351EBL, and 351FBL Access Panels as required.

- (2) Remove all magnetic fasteners from the left horizontal stabilizer between HSS 35.00 to HSS 74.00. (Refer to the King Air Structural Inspection and Repair Manual, Chapter 20, Fastener Installation and Removal.)
- (3) Remove all foreign object debris (FOD).
- (4) Apply Color Chemical Film Treatment to the rivet holes.
- (5) Apply Corrosion-Resistant Epoxy Primer to the rivet holes.
- (6) (Refer to Figure 1, Sheet 1.) Install either a 132368AD4-4 Rivet or a 132370AD4-4 Rivet as required, into all open rivet holes. (Refer to the King Air Structural Inspection and Repair Manual, Chapter 20, Fastener Installation and Removal.)

NOTE: It is permitted to install a 132368AD4-4 Rivet or a 132370AD4-4 Rivet. Prior to installation of any rivet match the fastener heads to the countersunk or dimples size.

NOTE: If the removed fasteners are oversized, it is permitted to use oversized 132368AD5 Rivet or a 132370AD5 Rivet into the oversized holes.

- B. For magnetic fasteners on the trailing edge of the left between HSS 35.00 and HSS 66.00 on the trailing edge of the left horizontal stabilizer do as follows:

- (1) Remove the left elevator if required. (Refer to the applicable Maintenance Manual, Chapter 27, Elevator - Removal/Installation.)
- (2) Remove all attach fasteners from the 101-620010-9 Cove Closure. (Refer to the King Air Structural Inspection and Repair Manual, Chapter 20, Fastener Installation and Removal.)
- (3) Remove all foreign object debris (FOD).
- (4) Apply Color Chemical Film Treatment to the rivet holes.
- (5) Apply Corrosion-Resistant Epoxy Primer to the rivet holes.
- (6) Install the 101-620010-9 Cove Closure with a NAS1739E-4-4 Rivet into all open rivet holes. (Refer to the King Air Structural Inspection and Repair Manual, Chapter 20, Fastener Installation and Removal.)

4. Repeat Step 2 for the right horizontal stabilizer.
5. Touch up paint using shop and local practices.
6. Install the left and right elevators if removed. (Refer to the applicable Maintenance Manual, Chapter 27, Elevator - Removal/Installation.)
7. Install all access panels that were removed for this service letter. (Refer to the applicable Maintenance Manual, Chapter 6, Airplane Access Panels - Description and Operation.)
8. Remove the maintenance warning tags and connect the airplane battery.
9. Make an entry in the airplane logbook that states compliance and method of compliance with this service document.

NOTE: Textron Aviation recommends that compliance with all service documents is reported to a maintenance tracking system provider.

- Complete a record of compliance. (Maintenance Transaction Report, Log Book Entry, or other record of compliance.)
- Put a copy of the completed record of compliance in the airplane logbook.
- Send a copy of the completed record of compliance to the maintenance tracking system provider used.

E77628

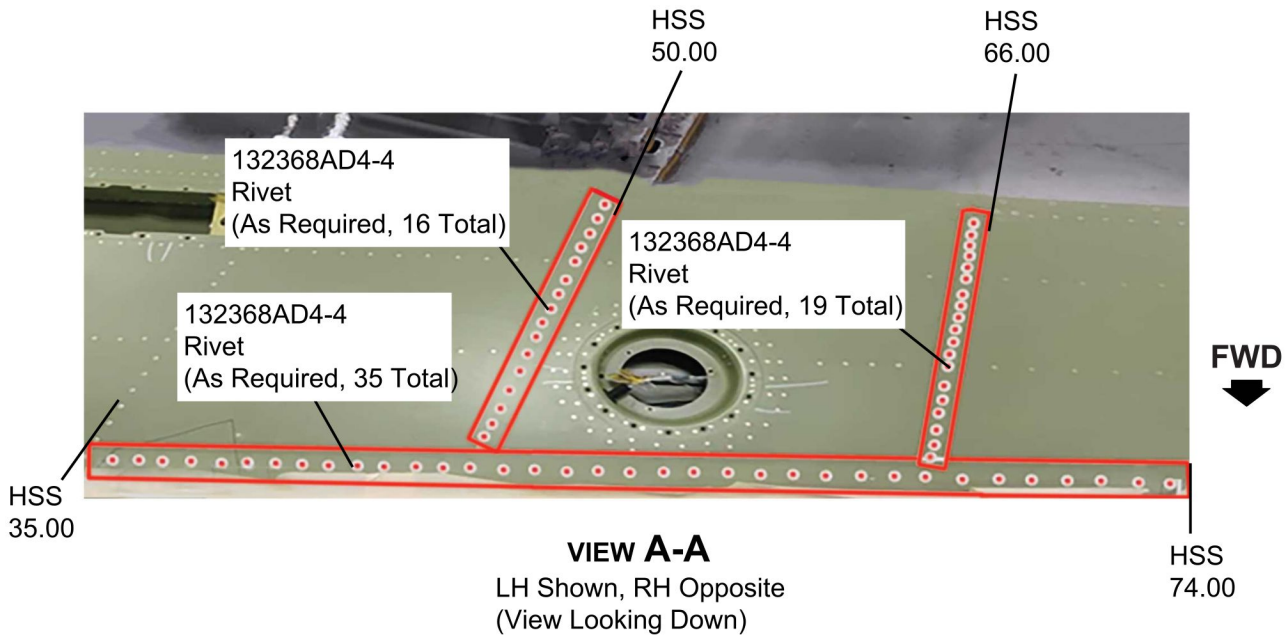
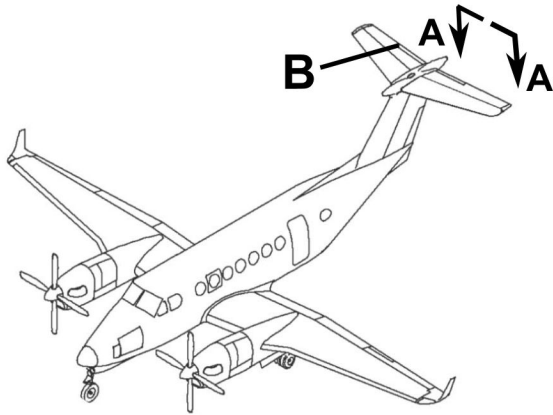

NOTE: Only the areas highlighted in red needs to be inspected for magnetic fasteners.

Figure 1. Horizontal Fastener Location (Sheet 1)

E77922



DETAIL B

RH Shown, LH Opposite
(View Looking Down)

NOTE: Only the rivets that attach the 101-620010-9 Cove Closure needs to be inspected on the upper surface.

Figure 1. Horizontal Fastener Location (Sheet 2)

MATERIAL INFORMATION

The part below may be required to complete this service letter.

NEW P/N	QUAN- TITY	KEY WORD	OLD P/N	INSTRUCTIONS/ DISPOSITION
132368AD4-4	As Required	Rivet	N/A	Discard old. Install new.
132370AD4-4	As Required	Rivet	N/A	Discard old. Install new.
NAS1739E-4-4	As Required	Rivet	N/A	Discard old. Install new.

* Please contact your Regional Textron Aviation Parts Distribution Customer Support Team for current cost and availability of parts listed in this service document. Phone at 1-800-835-4000 (Domestic) or 1-316-517-5603 (International).

For more information, please visit the TAPD Support & Aftermarket Account Management website at <https://ww2.txtav.com/Parts/Promos/TAPD>.

Based on availability and lead times, parts may require advanced scheduling.

TITLE

STABILIZERS - HORIZONTAL FASTENER REPLACEMENT

TO:

Beechcraft Model B200GT, B300, and B300C Aircraft Owner

REASON

Magnetic fasteners might have been installed in the left or right horizontal stabilizers, which might cause interference with the left or right flux detector unit.

COMPLIANCE

RECOMMENDED. This service document should be accomplished at a scheduled maintenance period or inspection.

LABOR HOURS

WORK PHASE	LABOR-HOURS
Modification	17
Inspection	1

MATERIAL AVAILABILITY

PART NUMBER	AVAILABILITY	COST
132368AD4-4	*	*
132370AD4-4	*	*
NAS1739E-4-4	*	*

* Please contact your Regional Textron Aviation Parts Distribution Customer Support Team for current cost and availability of parts listed in this service document. Phone at 1-800-835-4000 (Domestic) or 1-316-517-5603 (International).

For more information, please visit the TAPD Support & Aftermarket Account Management website at <https://ww2.txtav.com/Parts/Promos/TAPD>.

Based on availability and lead times, parts may require advanced scheduling.

WARRANTY

This service document is *recommended*. Eligible airplanes may qualify for parts and labor coverage to the extent noted in the *Labor Hours* and *Material Availability* sections of this document.

October 17, 2023

MTL-55-02
Page 1 of 2

 Textron Aviation Customer Service, P.O. Box 7706, Wichita, KS 67277, U.S.A. 1-316-517-5800

This document contains technical data and is subject to U.S. export regulations. This information has been exported from the United States in accordance with export administration regulations. Diversion contrary to U.S. law is prohibited. ECCN: 9E991

Eligibility: Airplanes identified within the serial number effectivity of this service document must have active Airframe warranty coverage on the original issue date of this document and the coverage must be active on the day the work is accomplished.

Parts Coverage: Textron Aviation-owned and Textron Aviation-authorized Service Facilities, operators, or other maintenance facilities may submit a claim for the parts required to accomplish this service document as defined in the *Material Availability* section of this document.

Labor Coverage: Textron Aviation-owned and Textron Aviation-authorized Service Facilities rated to perform maintenance on the specific model of Beechcraft Aircraft may submit a claim for the labor necessary to accomplish this service document as defined in the *Labor Hours* section of this document.

Credit Application: After this service document has been accomplished, a claim must be submitted to Textron Aviation within 30 days of the service document completion. Claims for compliance of this service document are to be filed as a W4 type claim.

Please submit your claim form online at ww2.txtav.com/Parts or email the completed Textron Aviation Claim Form to warranty@txtav.com. If submitted on-line a Return Authorization will be provided. If a paper claim is submitted your claim will be entered into the system and a Return Authorization will be sent to you.

The Return Authorization must accompany any required return parts (see *Material Availability*), to the point of purchase.

Parts to be returned to Textron Aviation Parts Distribution should be forwarded to:

TEXTRON AVIATION INC
CORE RETURNS
201 N GREENWICH RD BLDG 94
Wichita, KS 67206-2558

Expiration: October 17, 2025 (after this date the owner/operator assumes the responsibility for compliance costs)

Textron Aviation reserves the right to void continued airplane warranty coverage for the parts affected by this service document until the service document is accomplished.

NOTE: As a convenience, service documents are now available online to all our customers through a simple, free-of-charge registration process. If you would like to sign up, please visit the Customer Access link at support.txtav.com to register.