

TITLE

PNEUMATIC - ENGINE FLOW PACK T-FITTING INSPECTION

EFFECTIVITY

MODEL	SERIAL NUMBERS
B300C	FM-66, FM-67, FM-71, FM-73, FM-74, FM-76, FM-78, FM-79, FM-82, FM-84, FM-85, FM-86, FM-90, FM-91
B300	FL-1080, FL-1083, FL-1112, FL-1114, FL-1118, FL-1120, FL-1157, FL-1164, FL-1167, FL-1190, FL-1191, FL-1192, FL-1198, FL-1221, FL-1225, FL-1232

REASON

The T-fitting on the left and right engine bleed air system flow pack may not have been installed properly, thus causing engine bleed air to leak into the left and right cowlings.

DESCRIPTION

This service document provides parts and instructions to replace the tube assembly in the engine bleed air system.

COMPLIANCE

RECOMMENDED. This service document should be accomplished at a scheduled maintenance period or inspection.

A service document published by Textron Aviation may be recorded as *completed* in an aircraft log only when the following requirements are satisfied:

- 1) The mechanic must complete all of the instructions in the service document, including the intent therein.
- 2) The mechanic must correctly use and install all applicable parts supplied with the service document kit. Only with written authorization from Textron Aviation can substitute parts or rebuilt parts be used to replace new parts.
- 3) The mechanic or airplane owner must use the technical data in the service document only as approved and published.
- 4) The mechanic or airplane owner must apply the information in the service document only to aircraft serial numbers identified in the *Effectivity* section of the document.
- 5) The mechanic or airplane owner must use maintenance practices that are identified as acceptable standard practices in the aviation industry and governmental regulations.

No individual or corporate organization other than Textron Aviation is authorized to make or apply any changes to a Textron Aviation-issued service document or flight manual supplement without prior written consent from Textron Aviation.

Textron Aviation is not responsible for the quality of maintenance performed to comply with this document, unless the maintenance is accomplished at a Textron Aviation-owned Service Center.

November 3, 2023

MTL-36-01
Page 1 of 6

Textron Aviation Customer Service, P.O. Box 7706, Wichita, KS 67277, U.S.A. 1-316-517-5800

This document contains technical data and is subject to U.S. export regulations. This information has been exported from the United States in accordance with export administration regulations. Diversion contrary to U.S. law is prohibited. ECCN: 9E991

CONSUMABLE MATERIAL

You must use the consumable materials that follow, or their equivalent, to complete this service document.

NAME	NUMBER	MANUFACTURER	USE
Fiberglass Insulation	BS272-HH	Textron Aviation Parts Distribution 7121 Southwest Boulevard Wichita, KS 67215	
Aluminum Foil Tape	002X3W	Textron Aviation Parts Distribution 7121 Southwest Boulevard Wichita, KS 67215	

TOOLING

No specialized tooling is required to complete this service document.

REFERENCES

Beechcraft Super King Air B300/B300C Fusion Maintenance Manual

Beechcraft King Air Chapter 20 Standard Practices Manual - Airframe

PUBLICATIONS AFFECTED

None

ACCOMPLISHMENT INSTRUCTIONS

1. Prepare the airplane for maintenance.
 - A. Make sure that the airplane is electrically grounded.
 - B. Make sure that all switches are in the OFF/NORM position.
 - C. Disconnect electrical power from the airplane.
 - (1) Disconnect external electrical power.
 - (2) Disconnect the main airplane battery.
 - D. Attach maintenance warning tags to the battery and external power receptacle that have **"DO NOT CONNECT ELECTRICAL POWER - MAINTENANCE IN PROGRESS"** written on them.
2. Open the left engine cowl door. (Refer to the Beechcraft Super King Air B300/B300C Fusion Maintenance Manual, Chapter 71, Upper Aft Cowling - Removal/Installation.)
3. Depending upon the customer's engine model go to the steps as follows:
 - A. Customers with a PT6A-67 engine installed, go to Step 4.
 - B. Customer's with a PT6A-60A engine installed, go to Step 5.
4. (Refer to Figure 1, Sheet 1 and 2.) For airplanes fitted with PT6A-67 engine, do an inspection of the LH engine bleed air system tube assembly.
 - A. If 101-910150-67 Tube Assembly is installed, go to Step 6.
 - B. If 101-910150-67 Tube Assembly is not installed, do as follows:
 - (1) Remove and keep the heat shield that surrounds the T-Fitting.
 - (2) Disconnect both ends of the 101-910150-85 Tube Assembly from the bulkhead union and T-fitting.
 - (a) Remove and discard the 101-910150-85 Tube Assembly.
 - (3) Tighten the T-Fitting. (Refer to the Beechcraft King Air Standard Practices Manual, Chapter 20, Tubing, Hose and Fittings - Maintenance Practices.)

- (4) Insulate the 101-910150-67 Tube Assembly with BS272-HH Fiberglass Insulation and wrap with 002X3W Aluminum Foil Tape.
 - (5) Connect new 101-910150-67 Tube Assembly to the bulkhead union and T-fitting.
 - (a) Torque the nuts at both ends. (Refer to the Beechcraft King Air Standard Practices Manual, Chapter 20, Torque Application - Maintenance Practices.)
 - (6) Go to Step 6.
5. (Refer to Figure 1, Sheet 1 and 2.) For airplanes fitted with PT6A-60A engine, do an inspection of the LH engine bleed air system tube assembly.
- A. If 101-910150-85 Tube Assembly is installed, go to Step 6.
 - B. If 101-910150-85 Tube Assembly is not installed, do as follows:
 - (1) Remove and keep the heat shield that surrounds the T-Fitting.
 - (2) Disconnect both ends of the 101-910150-67 Tube assembly from the bulkhead union and T-fitting.
 - (a) Remove and discard the 101-910150-67 Tube Assembly.
 - (3) Tighten the T-Fitting. (Refer to the Beechcraft King Air Standard Practices Manual, Chapter 20, Tubing, Hose and Fittings - Maintenance Practices.)
 - (4) Connect new 101-910150-85 Tube Assembly to the bulkhead union and T-fitting.
 - (a) Torque the nut at both ends. (Refer to the Beechcraft King Air Standard Practices Manual, Chapter 20, Torque Application - Maintenance Practices.)
 - (5) Go to Step 6.
6. Repeat Step 2 for the RH engine bleed air system.
7. Do the Bleed Air Flow Rate Test (On Ground). (Refer to the Beechcraft Super King Air B300/B300C Fusion Maintenance Manual, Chapter 21, Bleed Air Flow Rate - Adjustment/Test.)
8. Install the kept heat shields onto the left and right engines, as necessary.
9. Close the left and right engine cowl door. (Refer to the Beechcraft Super King Air B300/B300C Fusion Maintenance Manual, Chapter 71, Upper Aft Cowling - Removal/Installation.)
10. Remove the maintenance warning tags and connect the airplane battery.
11. Make an entry in the airplane logbook that states compliance and method of compliance with this service document.

NOTE: Textron Aviation recommends that compliance with all service documents is reported to a maintenance tracking system provider.

- Complete a record of compliance. (Maintenance Transaction Report, Log Book Entry, or other record of compliance.)
- Put a copy of the completed record of compliance in the airplane logbook.
- Send a copy of the completed record of compliance to the maintenance tracking system provider used.

E77699

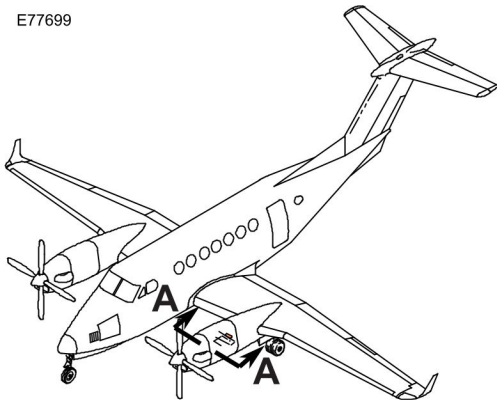

For PT6A-67 Engine,
101-910150-85 (LH)
101-910150-86 (RH)
Tube Assembly
(Discard)
101-910150-67 (LH)
101-910150-69 (RH)
Tube Assembly
(1 Each Required)

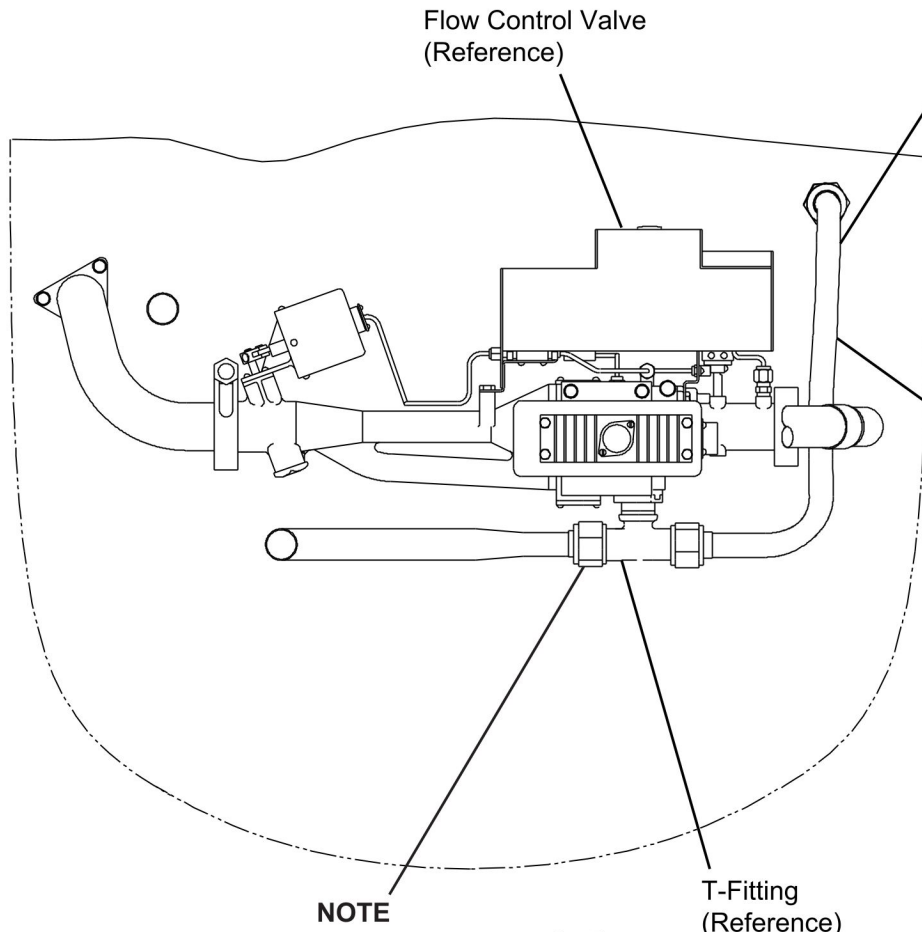

For PT6A-60A Engine,
101-910150-67 (LH)
101-910150-69 (RH)
Tube Assembly
(Discard)
101-910150-85 (LH)
101-910150-86 (RH)
Tube Assembly
(1 Each Required)

NOTE
VIEW A-A
View Looking Aft
(LH Shown, RH Opposite)

NOTE: The heat shield is not shown for clarity.

Figure 1. Engine Bleed Air System Tube Assembly Replacement (Sheet 1)

E77889

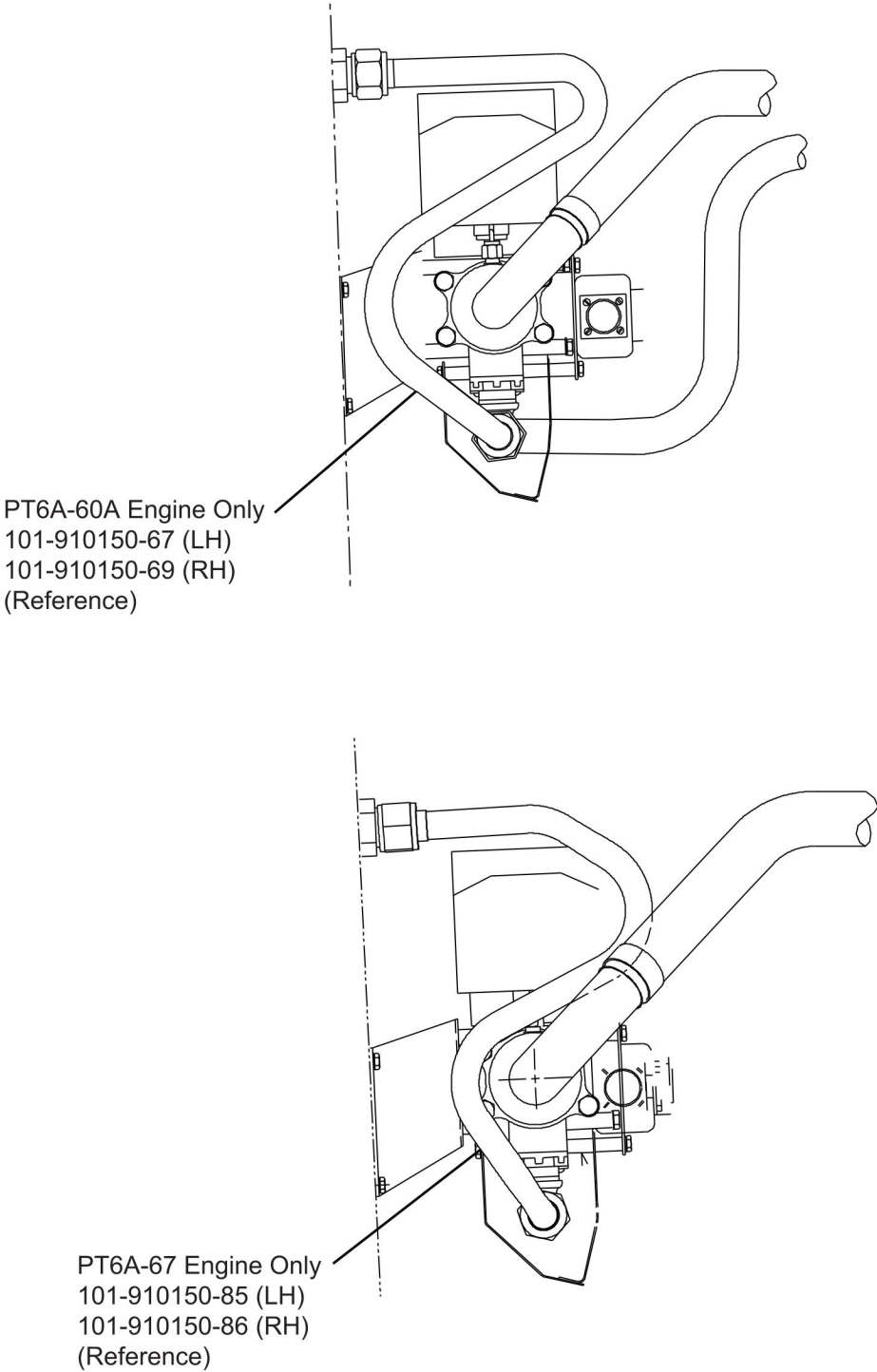

101-910150

Figure 1. Engine Bleed Air System Tube Assembly Replacement (Sheet 2)

MATERIAL INFORMATION

Order the part below to install this modification.

NEW P/N	QUAN- TITY	KEY WORD	OLD P/N	INSTRUCTIONS/ DISPOSITION
101-910150-67 (Airplanes with PT6A-67 engine)	1	LH Tube Assembly	101-910150-85	Discard
101-910150-69 (Airplanes with PT6A-67 engine)	1	RH Tube Assembly	101-910150-86	Discard
101-910150-85 (Airplanes with PT6A-60A engine)	1	LH Tube Assembly	101-910150-67	Discard
101-910150-86 (Airplanes with PT6A-60A engine)	1	RH Tube Assembly	101-910150-69	Discard

* Please contact your Regional Textron Aviation Parts Distribution Customer Support Team for current cost and availability of parts listed in this service document. Phone at 1-800-835-4000 (Domestic) or 1-316-517-5603 (International).

For more information, please visit the TAPD Support & Aftermarket Account Management website at <https://ww2.txtav.com/Parts/Promos/TAPD>.

Based on availability and lead times, parts may require advanced scheduling.

TITLE

PNEUMATIC - ENGINE FLOW PACK T-FITTING INSPECTION

TO:

Beechcraft Model B300 and B300C Aircraft Owner

REASON

The T-fitting on the left and right engine bleed air system flow pack may not have been installed properly, thus causing engine bleed air to leak into the left and right cowlings.

COMPLIANCE

RECOMMENDED. This service document should be accomplished at a scheduled maintenance period or inspection.

LABOR HOURS

WORK PHASE	LABOR-HOURS
Modification	8
Test and Inspection	1

MATERIAL AVAILABILITY

PART NUMBER	AVAILABILITY	COST
101-910150-67 (Airplanes with PT6A-67 engine)	*	*
101-910150-69 (Airplanes with PT6A-67 engine)	*	*
101-910150-85 (Airplanes with PT6A-60A engine)	*	*
101-910150-86 (Airplanes with PT6A-60A engine)	*	*

* Please contact your Regional Textron Aviation Parts Distribution Customer Support Team for current cost and availability of parts listed in this service document. Phone at 1-800-835-4000 (Domestic) or 1-316-517-5603 (International).

For more information, please visit the TAPD Support & Aftermarket Account Management website at <https://ww2.txtav.com/Parts/Promos/TAPD>.

Based on availability and lead times, parts may require advanced scheduling.

WARRANTY

This service document is *recommended*. Eligible airplanes may qualify for parts and labor coverage to the extent noted in the *Labor Hours* and *Material Availability* sections of this document.

November 3, 2023

MTL-36-01
Page 1 of 2

Textron Aviation Customer Service, P.O. Box 7706, Wichita, KS 67277, U.S.A. 1-316-517-5800

This document contains technical data and is subject to U.S. export regulations. This information has been exported from the United States in accordance with export administration regulations. Diversion contrary to U.S. law is prohibited. ECCN: 9E991

Eligibility: Airplanes identified within the serial number effectivity of this service document must have active Airframe warranty coverage on the original issue date of this document and the coverage must be active on the day the work is accomplished.

Parts Coverage: Textron Aviation-owned and Textron Aviation-authorized Service Facilities, operators, or other maintenance facilities may submit a claim for the parts required to accomplish this service document as defined in the *Material Availability* section of this document.

Labor Coverage: Textron Aviation-owned and Textron Aviation-authorized Service Facilities rated to perform maintenance on the specific model of Beechcraft Aircraft may submit a claim for the labor necessary to accomplish this service document as defined in the *Labor Hours* section of this document.

Credit Application: After this service document has been accomplished, a claim must be submitted to Textron Aviation within 30 days of the service document completion. Claims for compliance of this service document are to be filed as a W4 type claim.

Please submit your claim form online at ww2.txtav.com/Parts or email the completed Textron Aviation Claim Form to warranty@txtav.com. If submitted on-line a Return Authorization will be provided. If a paper claim is submitted your claim will be entered into the system and a Return Authorization will be sent to you.

The Return Authorization must accompany any required return parts (see *Material Availability*), to the point of purchase.

Parts to be returned to Textron Aviation should be forwarded to:

TEXTRON AVIATION INC
CORE RETURNS
201 N GREENWICH RD BLDG 94
Wichita, KS 67206-2558

Expiration: November 3, 2025 (after this date the owner/operator assumes the responsibility for compliance costs)

Textron Aviation reserves the right to void continued airplane warranty coverage for the parts affected by this service document until the service document is accomplished.

NOTE: As a convenience, service documents are now available online to all our customers through a simple, free-of-charge registration process. If you would like to sign up, please visit the Customer Access link at support.txtav.com to register.