

**TITLE**

LIGHTS - LED TAIL STROBE LIGHT INSTALLATION

**EFFECTIVITY**

<b>MODEL</b>	<b>SERIAL NUMBERS</b>
F90	LA-226 and On
B200	BB-1133, BB-1141, BB-1145 and On
B200C	BL-69 and On
B200CT	BN-5 and On
B200T	BT-30 and On
B200GT	BY-1 thru BY-408
B200CGT	BZ-1 thru BZ-3
300/300LW	FA-2 and On
B300C	FN-1
B300	FL-1 thru FL-1273
B300C	FM-1 thru FM-103
1900C	UB-62 thru UB-74, UC-1 and On

The equivalent of this service document has been incorporated on production airplanes: BY-409 and On, BZ-4 and ON, FL-1274 and ON, and FM-104 and ON.

**REASON**

The original tail nav/strobe light is no longer available. A new LED tail nav/strobe light is available as a replacement.

**DESCRIPTION**

This service document provides parts and instructions to remove the original tail nav/strobe light and associated wiring. Then install a new wiring harness and LED tail nav/strobe light assembly with the associated brackets.

**COMPLIANCE**

OPTIONAL. This service document can be accomplished at the discretion of the owner.

A service document published by Textron Aviation may be recorded as *completed* in an aircraft log only when the following requirements are satisfied:

- 1) The mechanic must complete all of the instructions in the service document, including the intent therein.
- 2) The mechanic must correctly use and install all applicable parts supplied with the service document kit. Only with written authorization from Textron Aviation can substitute parts or rebuilt parts be used to replace new parts.
- 3) The mechanic or airplane owner must use the technical data in the service document only as approved and published.

November 14, 2022

MTB-33-03  
Page 1 of 15

Textron Aviation Customer Service, P.O. Box 7706, Wichita, KS 67277, U.S.A. 1-316-517-5800

This document contains technical data and is subject to U.S. export regulations. This information has been exported from the United States in accordance with export administration regulations. Diversion contrary to U.S. law is prohibited. ECCN: 9E991

- 4) The mechanic or airplane owner must apply the information in the service document only to aircraft serial numbers identified in the *Effectivity* section of the document.
- 5) The mechanic or airplane owner must use maintenance practices that are identified as acceptable standard practices in the aviation industry and governmental regulations.

No individual or corporate organization other than Textron Aviation is authorized to make or apply any changes to a Textron Aviation-issued service document or flight manual supplement without prior written consent from Textron Aviation.

Textron Aviation is not responsible for the quality of maintenance performed to comply with this document, unless the maintenance is accomplished at a Textron Aviation-owned Service Center.

### APPROVAL

Textron Aviation received FAA approval for the technical data in this publication that changes the airplane type design.

### FLIGHT CREW OPERATIONS

No Changes

### CONSUMABLE MATERIAL

You must use the consumable materials that follow, or their equivalent, to complete this service document.

NAME	NUMBER	MANUFACTURER	USE
Adhesive	EA9309, Type I, Class B (EA9309.3NA 25 Grams)	Textron Aviation Parts Distribution 7121 Southwest Boulevard Wichita, KS 67215	To attach mounts to the tail fairing.
Sealant	U470638 Type I, Class B-1/2, (3.5 oz Simkit)	Textron Aviation Parts Distribution 7121 Southwest Boulevard Wichita, KS 67215	To electrically bond light assembly to the tail fairing.
Isopropyl Alcohol		Commercially Available	To clean access sealant between the light assembly and tail fairing.

### TOOLING

No specialized tooling is required to complete this service document.

### WEIGHT AND BALANCE INFORMATION

The weight and moment changes for the Models F90 and 1900C are negligible.

<b>MODEL</b>	All B200 Models	All 300/B300 Models
<b>WEIGHT CHANGE</b>	- 1.8 pounds	- 2.6 pounds
<b>RESULTANT MOMENT</b>	- 918 inch-pounds	- 1413 inch-pounds
<b>MOMENT/100</b>	- 9.18 inch-pounds	- 14.13 inch-pounds

### REFERENCES

Beechcraft King Air F90 Series Maintenance Manual

Beechcraft 200 Series Aircraft Maintenance Manual

Beechcraft Super King Air B200GT/B200CGT Fusion Maintenance Manual

Beechcraft 300/300LW Maintenance Manual

Beechcraft Super King Air B300/B300C Maintenance Manual

Beechcraft Super King Air B300/B300C Fusion Maintenance Manual

Beechcraft Model 1900/1900C Airliner Maintenance Manual

Beechcraft Model 1900 Airliner Series Structural Repair Manual

Beechcraft King Air Chapter 20 Standard Practices - Airframe

#### **PUBLICATIONS AFFECTED**

Beechcraft King Air F90 Series Maintenance Manual

Beechcraft King Air F90 Illustrated Parts Catalog

Beechcraft King Air F90 Wiring Diagram Manual 109-590010-79

Beechcraft 200 Series Aircraft Maintenance Manual

Beechcraft 200/200T/200C/200CT Illustrated Parts Catalog

Beechcraft B200/B200T/B200C/B200CT Illustrated Parts Catalog

Beechcraft Super King Air B200GT/B200CGT Fusion Maintenance Manual

Beechcraft B200GT/B200CGT Illustrated Parts Catalog

Beechcraft B200/T Wiring Diagram Manual

Beechcraft 200C/CT, B200C/CT Series Wiring Diagram Manual

Beechcraft B200/T/CT/GT/CGT WDM (Pro Line 21 Avionics)

Beechcraft B200GT/B200CGT Fusion Wiring Diagram Manual

Beechcraft 300/300LW Maintenance Manual

Beechcraft Super King Air B300/B300C Maintenance Manual

Beechcraft Super King Air B300/B300C Fusion Maintenance Manual

Beechcraft 300/300LW Illustrated Parts Catalog

Beechcraft B300/B300C Illustrated Parts Catalog FL-1 thru FL-600, FI-602 thru FL-671, FL-673 thru FL-687; FM-1 thru FM-35

Beechcraft B300/B300C Illustrated Parts Catalog FL-601, FL-672, FL-688, and After, FM-36 and After

Beechcraft 300/300LW Wiring Diagram

Beechcraft 350i Wiring Diagram Manual with Cabinet Management System

Beechcraft B300/B300C Avionics Wiring Diagram Manual

Beechcraft Super King Air Model B300/B300C Fusion Wiring Diagram Manual

Beechcraft Model 1900/1900C Airliner Maintenance Manual

Beechcraft Model 1900/1900C Illustrated Parts Catalog UA-1 and After, UB-1 and After

Beechcraft Model 1900C Wiring Diagram Manual UB-1 and After

Beechcraft Model 1900C Wiring Diagram Manual UC-1 and After

#### **ACCOMPLISHMENT INSTRUCTIONS**

1. Prepare the airplane for maintenance.
  - A. Make sure that the airplane is electrically grounded.
  - B. Make sure that all switches are in the OFF/NORM position.

- C. Disconnect electrical power from the airplane.
- (1) Disconnect external electrical power.
  - (2) Disconnect the airplane battery.
- D. Attach maintenance warning tags to the battery and external power receptacle that have "**DO NOT CONNECT ELECTRICAL POWER - MAINTENANCE IN PROGRESS**" written on them.
- E. Depending upon the customer's airplane model use the references below as follows:

**MODEL F90**

- Refer to the Beechcraft King Air F90 Series Maintenance Manual, Chapter 55, Horizontal Stabilizers - Maintenance Practices (Effectivity: All)
- Refer to the Beechcraft King Air F90 Series Maintenance Manual, Chapter 20, Standard Practices - Airframe, Electrical Wiring - Description and Operation.
- Refer to the Beechcraft King Air F90 Series Maintenance Manual, Chapter 20, Standard Practices - Airframe, Electrical Connectors - Maintenance Practices.
- Refer to the Beechcraft King Air F90 Series Maintenance Manual, Chapter 20, Standard Practices - Airframe, Sealing/Bonding - Maintenance Practices.
- Refer to the Beechcraft King Air F90 Series Maintenance Manual, Chapter 20, Standard Practices - Airframe, Electrical Bonding - Maintenance Practices.

**MODEL B200, B200C, B200CT, and B200T**

- Refer to the Beechcraft 200 Series Aircraft Maintenance Manual, Chapter 33, Lights - Tail Strobe Power Supply - Maintenance Practices (Airplanes with Power Supply P/N C70178-1 or 100-384118-XX Installed)
- Refer to the Beechcraft King Air Chapter 20 Standard Practices - Airframe, Electrical Wiring - Maintenance Practices.
- Refer to the Beechcraft King Air Chapter 20 Standard Practices - Airframe, Connectors - Maintenance Practices.
- Refer to the Beechcraft King Air Chapter 20 Standard Practices - Airframe, Sealing/Bonding - Maintenance Practices.
- Refer to the Beechcraft King Air Chapter 20 Standard Practices - Airframe, Electrical Bonding - Maintenance Practices.

**MODEL B200GT and B200CGT**

- Beechcraft Super King Air B200GT/B200CGT Fusion Maintenance Manual, Chapter 33, Lights - Tail Strobe Power Supply (If Installed) - Maintenance Practices.
- Refer to the Beechcraft King Air Chapter 20 Standard Practices - Airframe, Electrical Wiring - Maintenance Practices.
- Refer to the Beechcraft King Air Chapter 20 Standard Practices - Airframe, Connectors - Maintenance Practices.
- Refer to the Beechcraft King Air Chapter 20 Standard Practices - Airframe, Sealing/Bonding - Maintenance Practices.
- Refer to the Beechcraft King Air Chapter 20 Standard Practices - Airframe, Electrical Bonding - Maintenance Practices.

**MODEL 300 and 300LW**

- Refer to the Beechcraft 300/300LW Maintenance Manual, Chapter 55, Stabilizers - Vertical Stabilizers - Maintenance Practices.
- Refer to the Beechcraft 300/300LW Maintenance Manual, Chapter 20, Standard Practices - Airframe, Electrical Wiring - Description and Operation.
- Refer to the Beechcraft 300/300LW Maintenance Manual, Chapter 20, Standard Practices - Airframe, Electrical Connectors - Maintenance Practices.

- Refer to the Beechcraft 300/300LW Maintenance Manual, Chapter 20, Standard Practices - Airframe, Sealing/Bonding Description.
- Refer to the Beechcraft 300/300LW Maintenance Manual, Chapter 20, Standard Practices - Airframe, Electrical Bonding Description and Operation.

#### MODEL B300 and B300C

- Refer to the Beechcraft Super King Air B300/B300C Maintenance Manual, Chapter 33, Lights - Strobe Power Supply - Maintenance Practices.
- Refer to the Beechcraft King Air Chapter 20 Standard Practices - Airframe, Electrical Wiring - Maintenance Practices.
- Refer to the Beechcraft King Air Chapter 20 Standard Practices - Airframe, Connectors - Maintenance Practices.
- Refer to the Beechcraft King Air Chapter 20 Standard Practices - Airframe, Sealing/Bonding - Maintenance Practices.
- Refer to the Beechcraft King Air Chapter 20 Standard Practices - Airframe, Electrical Bonding - Maintenance Practices.

#### MODEL B300 and B300C (Fusion)

- Refer to the Beechcraft Super King Air B300/B300C Fusion Maintenance Manual, Chapter 33, Lights - Strobe Power Supply - Maintenance Practices.
- Refer to the Beechcraft King Air Chapter 20 Standard Practices - Airframe, Electrical Wiring - Maintenance Practices.
- Refer to the Beechcraft King Air Chapter 20 Standard Practices - Airframe, Connectors - Maintenance Practices.
- Refer to the Beechcraft King Air Chapter 20 Standard Practices - Airframe, Sealing/Bonding - Maintenance Practices.
- Refer to the Beechcraft King Air Chapter 20 Standard Practices - Airframe, Electrical Bonding - Maintenance Practices.

#### MODEL 1900C

- Refer to the Beechcraft Model 1900/1900C Airliner Maintenance Manual, Chapter 55, Stabilizers - Vertical Stabilizer - Maintenance Practices.
- Refer to the Beechcraft Model 1900/1900C Airliner Maintenance Manual, Chapter 20, Standard Practices - Airframe, Electrical Bonding - Maintenance Practices.
- Refer to the Beechcraft Model 1900 Airliner Series Structural Repair Manual, Chapter 51, Standard Practices - Structures, Sealing - Maintenance Practices.
- Refer to the Beechcraft Model 1900/1900C Airliner Maintenance Manual, Chapter 20, Standard Practices - Airframe, Electrical Wiring - Description and Operation.

2. Remove the aft tail fairing as follows: (Refer to the applicable maintenance manual for the aft horizontal/vertical stabilizer fairing location.)
  - A. Remove the aft cover plate from the top surface of the tail fairing.
  - B. Prior to disconnecting the electrical connectors, secure the harness as necessary to prevent the harness from dropping out of reach and into the vertical stabilizer.

**WARNING:** Although a bleed-off resistor is incorporated in the power supply circuit, high voltage is involved in the circuit between the power supply and light assemblies. For this reason, turn the control switch for the strobe lights OFF and wait for at least ten minutes to elapse before disconnecting the cables at the power supply and before handling or disassembling these units in any way. Failure to observe these precautions may result in physical injury or shock.

- C. Disconnect the electrical connectors from the strobe light power supply and the ground straps.

**NOTE:** Not all airplanes listed in this service document will have a power supply unit.

- D. Remove the aft tail fairing.
3. (Refer to Figure 1, Sheets 1 and 2.) Remove the aft tail strobe light assembly and wiring as follows:
  - A. Airplanes equipped with a 101-384118 Strobe Light Power Supply, go to Step 3 C.
  - B. Airplanes not equipped with a 101-384118 Strobe Light Power Supply, go to Step 3 F.
  - C. Remove and discard the four screws that attach the 101-384118 Strobe Light Power Supply.
  - D. Remove and discard the two mounting screws and washers that attach 101-3611549-0007 Strap Assembly to the bulkhead.
  - E. Discard the 101-3611549-0007 Strap Assembly.
  - F. Remove and discard the hardware that attaches the 101-361159-005 Light Assembly to the tail fairing.
  - G. Discard the 101-361159-005 Light Assembly and the associated harness.
4. (Refer to Figure 2, Sheets 1, 2, and 3.) Do the wiring modification to the airplane wiring harness as follows:
  - A. Remove and discard the P495 Connector.
  - B. Install a SJS840400 Pin Receptacle two M39029/58-364 Contact Pins and two MS27488-16 Sealing Plugs onto the existing airplane wiring harness.
  - C. Install a SJS840410 Pin Plug with three M39029/57-358 Sockets and one MS27488-16 Sealing Plug onto the existing airplane wiring harness.
  - D. Install and label each connector using one 131741-3 Marker Band onto the airplane wiring harness.
5. (Refer to Figure 3, Sheets 1 and 2.) Install the 130-366006-0001 Strobe Light and Wiring Harness Assembly as follows:
  - A. Apply EA9309 Adhesive to the two CB3019AA3NP Mounts.
  - B. Install the two CB3019AA3NP Mounts onto the upper surface of the tail fairing approximately 10.0 inches from the bulkhead and from each other.
  - C. Apply EA9309 Adhesive to the CB4020G3N8 Mount and install the CB4020G3N8 Mount to the forward side of the bulkhead in the tail fairing.
    - (1) Make sure the EA9309 Adhesive has had time to cure.
  - D. Install the wiring harness of the 130-366006-0001 Strobe Light and Wiring Harness Assembly from the aft end of the tail fairing.
  - E. Electrically bond the 130-366006-0001 Strobe Light and Wiring Harness Assembly to the aft end of the tail fairing.
    - (1) Apply adequate U470638 Sealant between the 130-366006-0001 Strobe Light and Wiring Harness Assembly and tail fairing.

**NOTE:** The U470638 Sealant should squeeze out when the two MS35206-235 Screws are installed.
    - (2) Install two MS35206-235 Screws through the 130-366006-0001 Strobe Light and Wiring Harness Assembly and the tail fairing.
    - (3) Make sure to clean off access sealant between the 130-366006-0001 Strobe Light and Wiring Harness Assembly and the tail fairing with Isopropyl Alcohol.
    - (4) Make sure that the electrical bond is no more than 0.01 Ohms.
  - F. Attach the wiring harness from the 130-366006-0001 Strobe Light and Wiring Harness Assembly with one MS3367-7-9 Cable Tie to each of the mounts that were attached to the tail fairing and bulkhead.
  - G. Install the tail fairing.

- H. Connect the wiring connectors as follows:
- (1) Connect J495 to P495.
  - (2) Connect P514 to J514.
6. Do an operational check of the 130-366006-0001 Strobe Light and Wiring Harness Assembly as follows:
- A. Remove the maintenance warning tags and connect the airplane battery.
  - B. Put the Master Avionics Switches to the ON Position.
  - C. Put the NAV LIGHT Switch to the ON Position.
    - (1) Make sure the tail position light illuminates a steady white light.
  - D. Put the STROBE LIGHT Switch to the ON Position
    - (1) Make sure the tail strobe light illuminates with a flashing white light.
  - E. Put the STROBE LIGHT and the NAV LIGHT Switches to the OFF position.
  - F. Put the Master Avionics Switches to the OFF Position.
7. Do an elevator control sweep and make sure that the wiring does not contact the moving control surface parts.
8. Install the aft cover plate onto the top surface of the tail fairing.
9. Make an entry in the airplane logbook that states compliance and method of compliance with this service document.

**NOTE:** Textron Aviation recommends that compliance with all service documents is reported to a maintenance tracking system provider.

- Complete a record of compliance. (Maintenance Transaction Report, Log Book Entry, or other record of compliance.)
- Put a copy of the completed record of compliance in the airplane logbook.
- Send a copy of the completed record of compliance to the maintenance tracking system provider used.



E77073

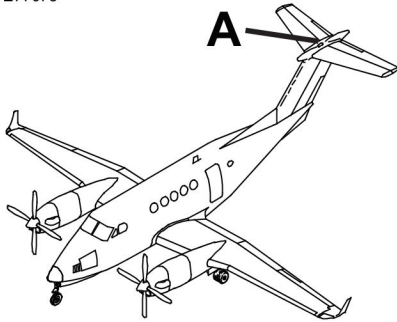

Aircraft Harness  
(Reference)

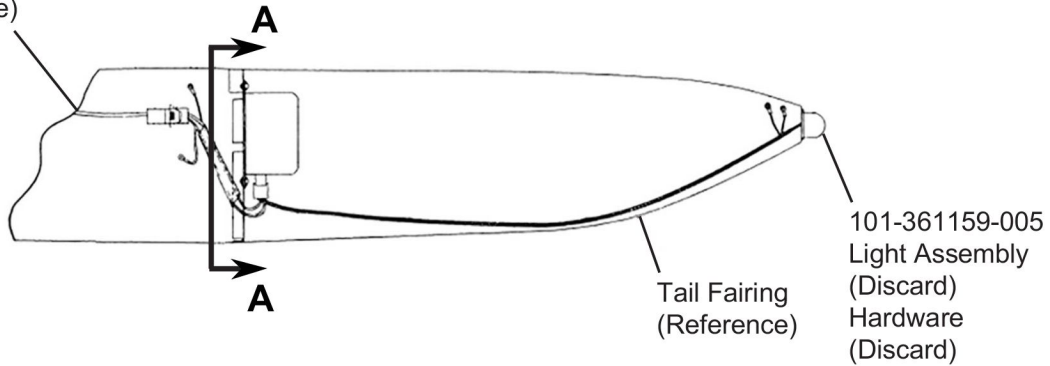

**DETAIL A**

(View Looking Outboard)

**NOTE:** The model shown is a B300, yet the location of the tail strobe light assembly is the same across all models.

130M366010

Figure 1. Before Modification (Sheet 1)



E77074

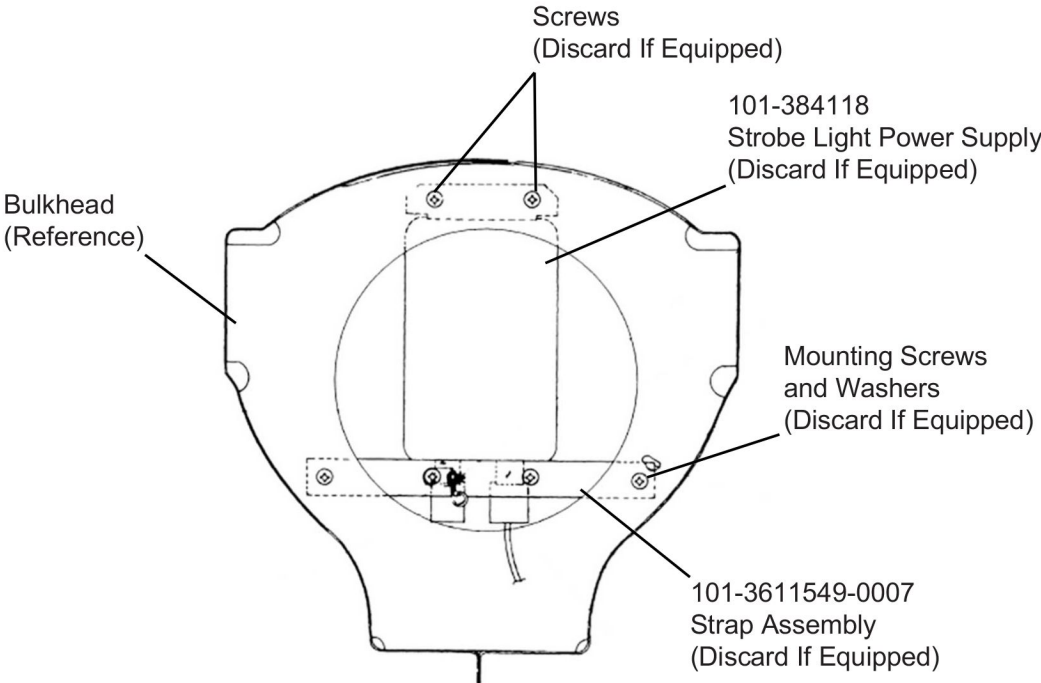

**VIEW A-A**  
(View Looking Aft)

130M366010

Figure 1. Before Modification (Sheet 2)

E77075

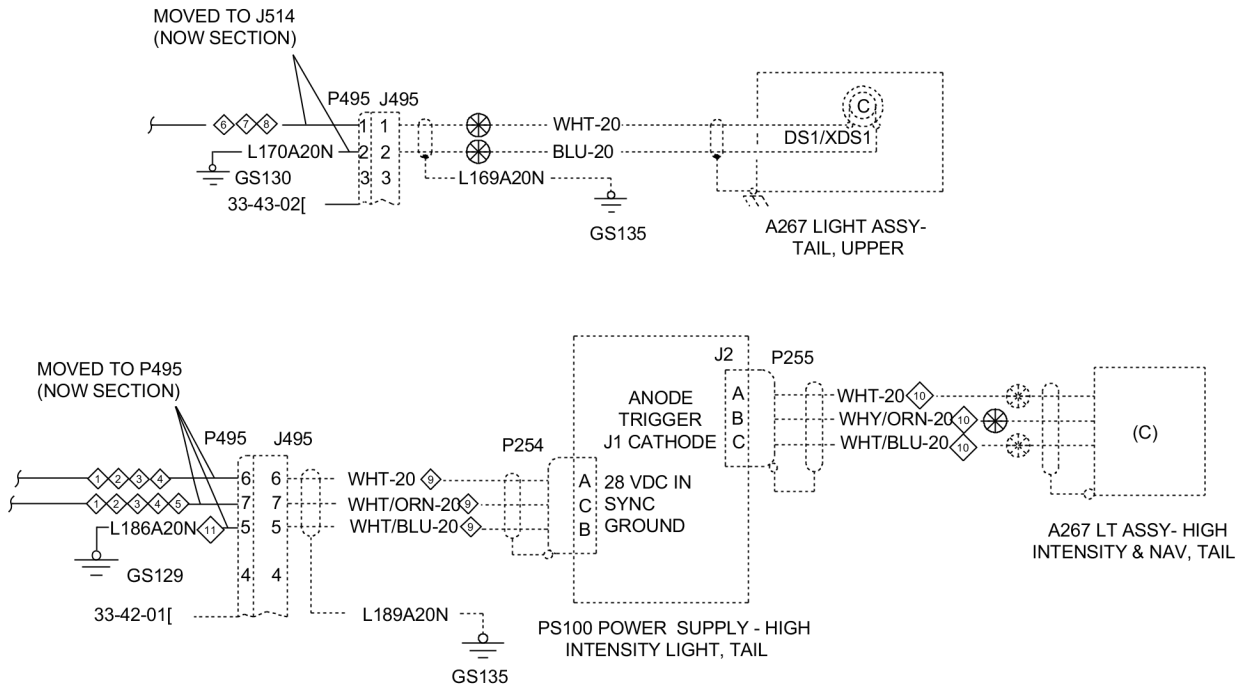

**NOTE:** All models listed may not be equipped with a strobe light power supply.

Legend	
-----	Removed Wiring

130M366010

Figure 2. Wiring Modifications (Sheet 1)

E77076

- SJS840400
- Pin Housing
- (1 Required)
- M39029/58-364
- Contact Pin
- MS27488-16
- Sealing Plug
- (2 Each Required)
- 131741-3
- Marker Band
- (1 Required)

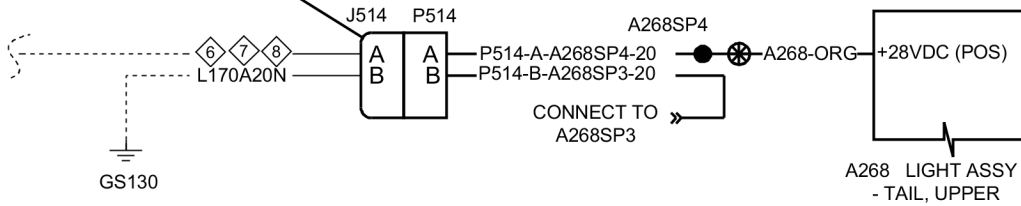

- SJS840410
- Pin Housing
- (1 Required)
- M39029/57-358
- Socket
- (3 Required)
- MS27488-16
- Sealing Plug
- 131741-3
- Marker Band
- (1 Each Required)

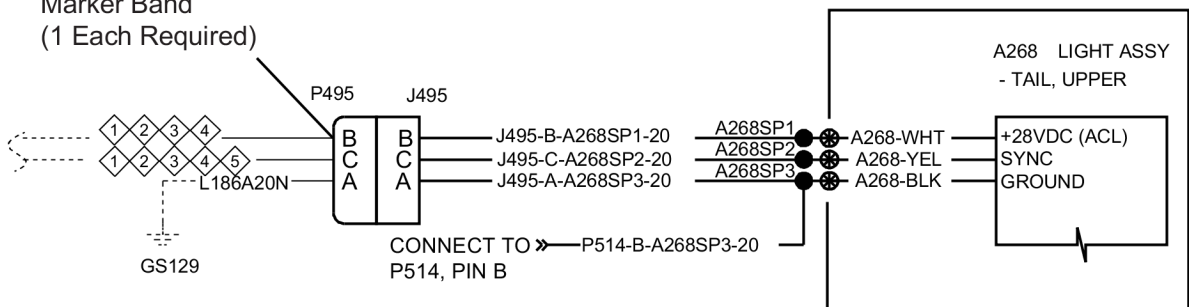

Legend	
—	New Wiring

130M366010

Figure 2. Wiring Modifications (Sheet 2)

E77077

① L182D20 } FL, FM  
 L184C20 }

② L182F20 } BB, BY, BZ, BL,  
 L184G20 } BT, BN, FA

③ L182F20 } UB, UC  
 L184F20 }

④ L182F20 } LA  
 L184G20 }

- ⑤ WIRE CAPPED & STOWED ON:
- FL-6 THRU FL-78
  - BB-1242 THRU BB-1833,  
BB-1835 THRU BB-1842
  - BT-31 & AFTER
  - FA-87 & AFTER
  - UB AIRCRAFT NOT COMPLYING  
WITH SERVICE BULLETIN 2332
  - UC-1 & AFTER

⑥ L168D20 } FL, FM, BB, BY, BZ,  
 BL, BT, BN, FA

⑦ L168E18 } UB

⑧ L168E20 } UC, LA

L182G20 }  
 ⑨ L184H20 } UB, LA  
 L186B20 }

⑩ RED } LA, UB, UC  
 BLU }  
 YEL }

⑪ INSTALLED IN PIN 7  
 FOR UC-54 & AFTER

Wiring Code Notes

130M366010

Figure 2. Wiring Modifications (Sheet 3)

E77078

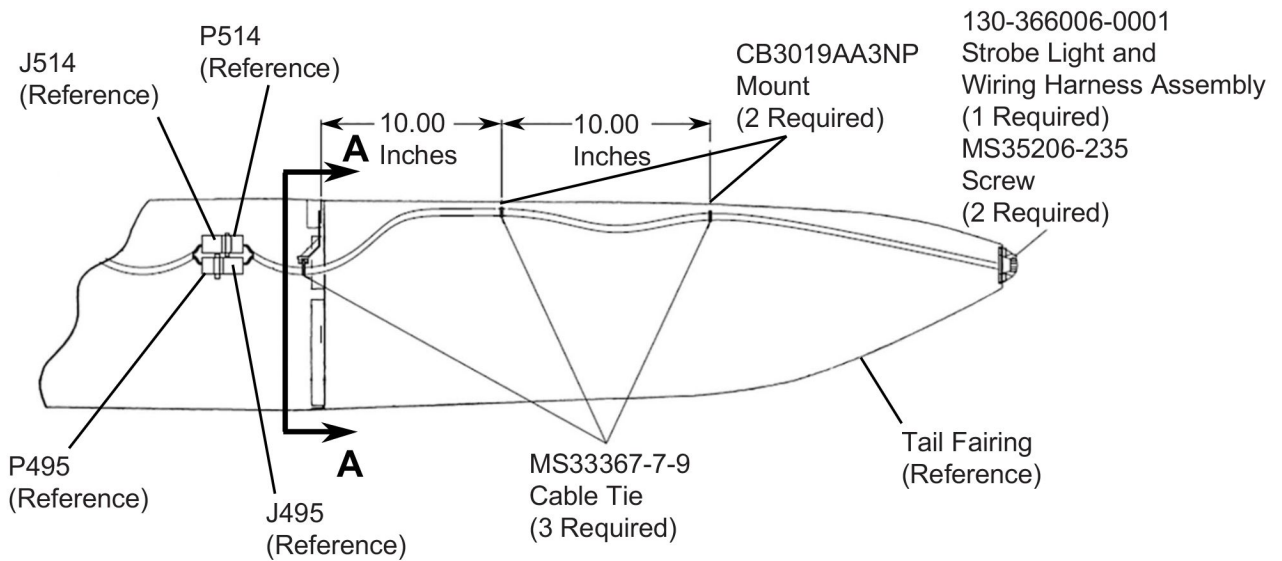
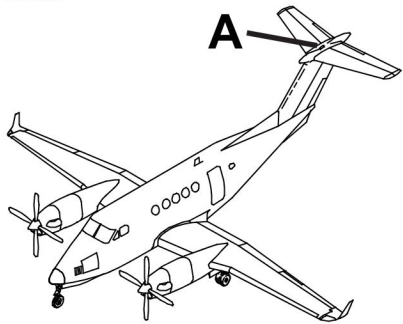

**DETAIL A**  
 (View Looking Outboard)

**NOTE:** The model shown is a B300, yet the installation of the 130-366006-0001 Strobe Light and Wiring Harness Assembly is the same across all models.

130M366010

Figure 3. After Modification (Sheet 1)

E77079

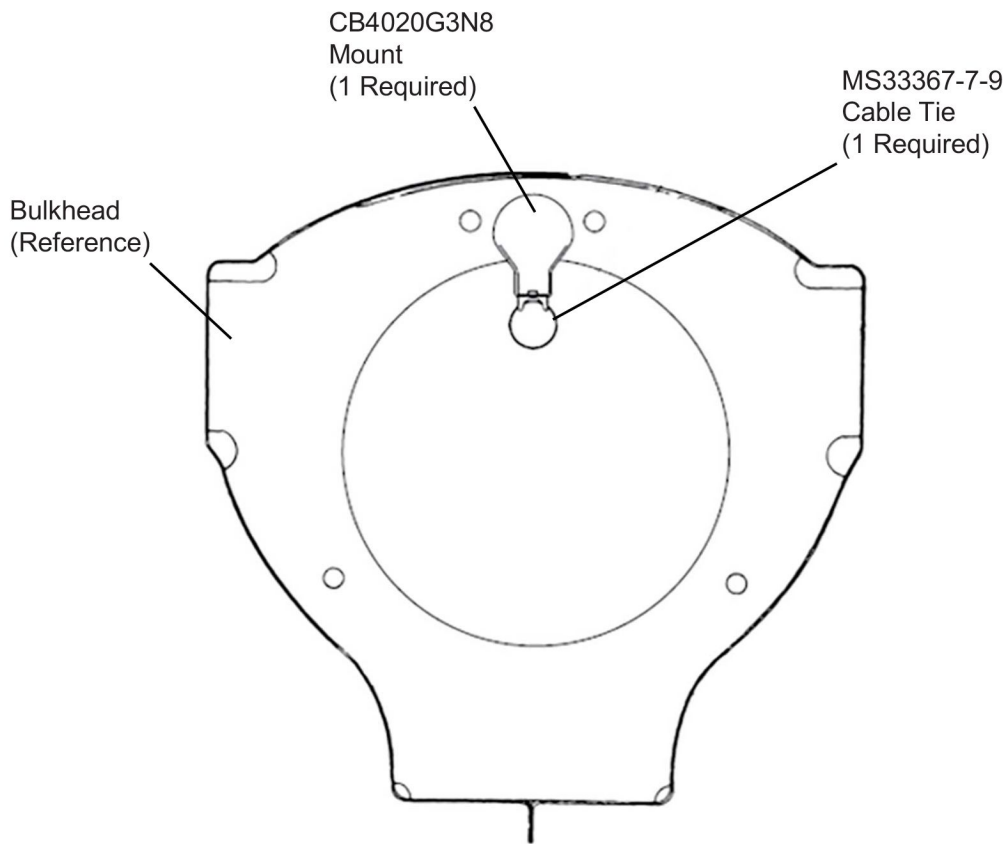

**VIEW A-A**  
(View Looking Aft)

Figure 3. After Modification (Sheet 2)

130M366010

**MATERIAL INFORMATION**

Order the kit below to install this modification.

NEW P/N	QUAN- TITY	KEY WORD	OLD P/N	INSTRUCTIONS/ DISPOSITION
<b>MTB-33-03</b>	1	<b>Kit</b> , consisting of the following parts:		
CB3019AA3NP	2	Mount	N/A	Install
CB4020G3N8	1	Mount	N/A	Install
MS27488-16	3	Sealing Plug	N/A	Install
MS3367-7-9	3	Cable Tie	N/A	Install
MS35206-235	2	Screw	N/A	Install
M39029/57-358	3	Socket	N/A	Install
M39029/58-364	2	Contact Pin	N/A	Install
SJS840400	1	4 Pin Receptacle	N/A	Install
SJS840410	1	4 Pin Plug	N/A	Install
130-366006-0001	1	Strobe Light and Wiring Harness Assembly	N/A	Install
131741-3	2	Marker Band	N/A	Install
MTB-33-03	1	Instructions		

\* Please contact your Regional Textron Aviation Parts Distribution Customer Support Team for current cost and availability of parts listed in this service document. Phone at 1-800-835-4000 (Domestic) or 1-316-517-5603 (International).

For more information, please visit the TAPD Support & Aftermarket Account Management website at <https://ww2.txtav.com/Parts/Promos/TAPD>.

Based on availability and lead times, parts may require advanced scheduling.





**TITLE**

LIGHTS - LED TAIL STROBE LIGHT INSTALLATION

**TO:**

Beechcraft Models F90, B200, B200C, B200CT, B200T, B200GT, B200CGT, 300, 300LW, B300C, B300, B300C, 1900C Aircraft Owners

**REASON**

The original tail nav/strobe light is no longer available. A new LED tail nav/strobe light is available as a replacement.

**COMPLIANCE**

OPTIONAL. This service document can be accomplished at the discretion of the owner.

**LABOR HOURS**

WORK PHASE	LABOR-HOURS
Modification	As Necessary
Test and Inspection	As Necessary

**MATERIAL AVAILABILITY**

PART NUMBER	AVAILABILITY	COST
MTB-33-03	*	*

\* Please contact your Regional Textron Aviation Parts Distribution Customer Support Team for current cost and availability of parts listed in this service document. Phone at 1-800-835-4000 (Domestic) or 1-316-517-5603 (International).

For more information, please visit the TAPD Support & Aftermarket Account Management website at <https://ww2.txtav.com/Parts/Promos/TAPD>.

Based on availability and lead times, parts may require advanced scheduling.

**WARRANTY**

None

**NOTE:** As a convenience, service documents are now available online to all our customers through a simple, free-of-charge registration process. If you would like to sign up, please visit the Customer Access link at [www.txtavsupport.com](http://www.txtavsupport.com) to register.

