



CT7-2E INCREMENTAL CHANGE

Release Notification Date: 11/01/2022

IPC 72-30-00 FIG. 01 COLD SECTION MODULE

GE Designated: -CONFIDENTIAL-

The information contained in this document is GE proprietary information and is disclosed in confidence. It is the property of GE and shall not be used, disclosed to others or reproduced without the express written consent of GE, including, but without limitation, it is not to be used in the creation, manufacture, development, or derivation of any repairs, modifications, spare parts, designs, or configuration changes or to obtain FAA or any other government or regulatory approval to do so. If consent is given for reproduction in whole or in part, this notice and the notice set forth on each page of this document shall appear in any such reproduction in whole or part.

This technical data is considered subject to the Export Administration Regulations (EAR) pursuant to 15 CFR Parts 730-774. Transfer of this data by any means to a Non-U.S. Person, whether in the United States or abroad, without the proper U.S. Government authorization (e.g., License, exemption, NLR, etc.), is strictly prohibited.

Copyright (2022) General Electric Company, U.S.A.

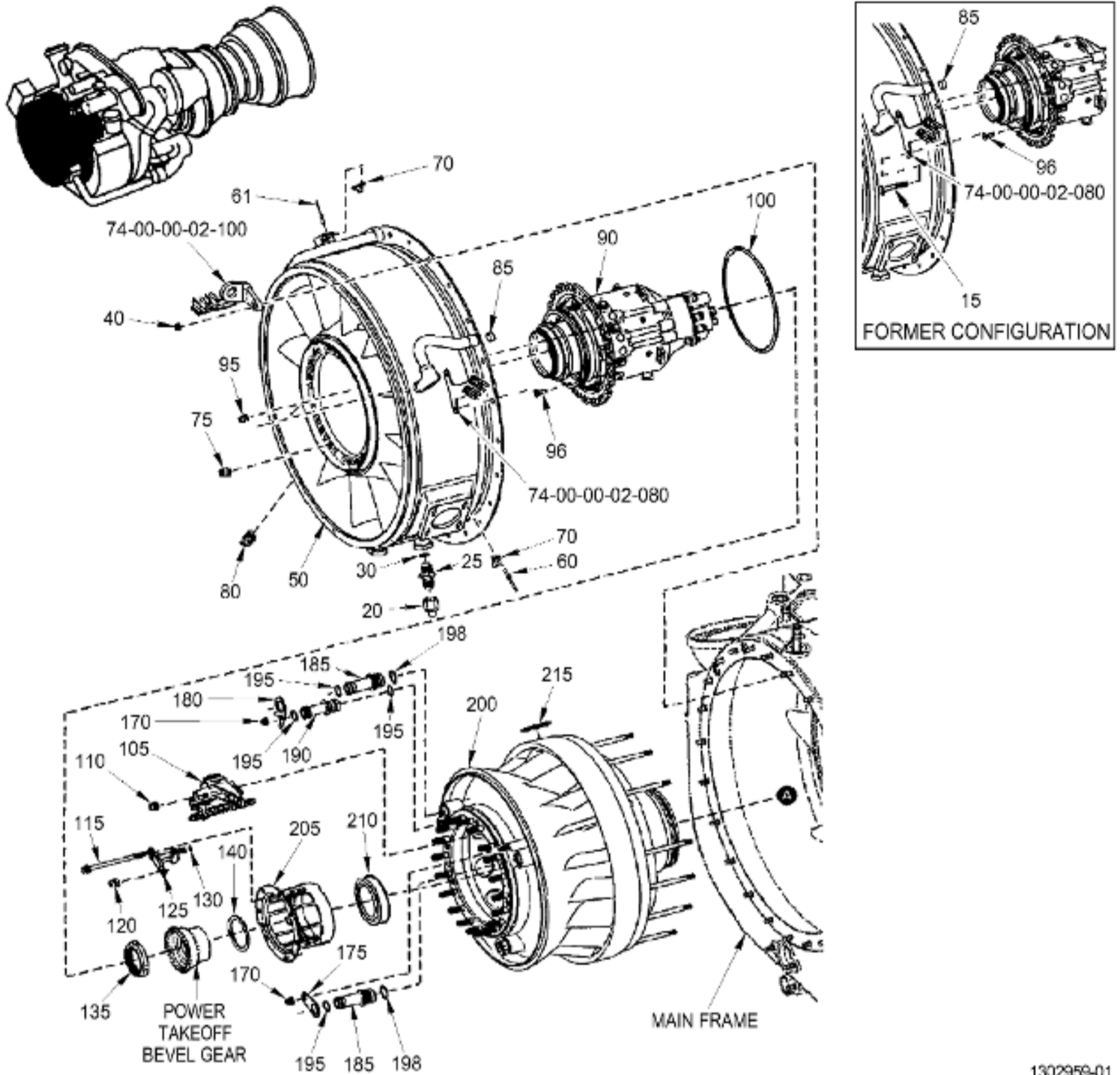

COLD SECTION MODULE
 Figure 01 (Sheet 1)

1302959-01

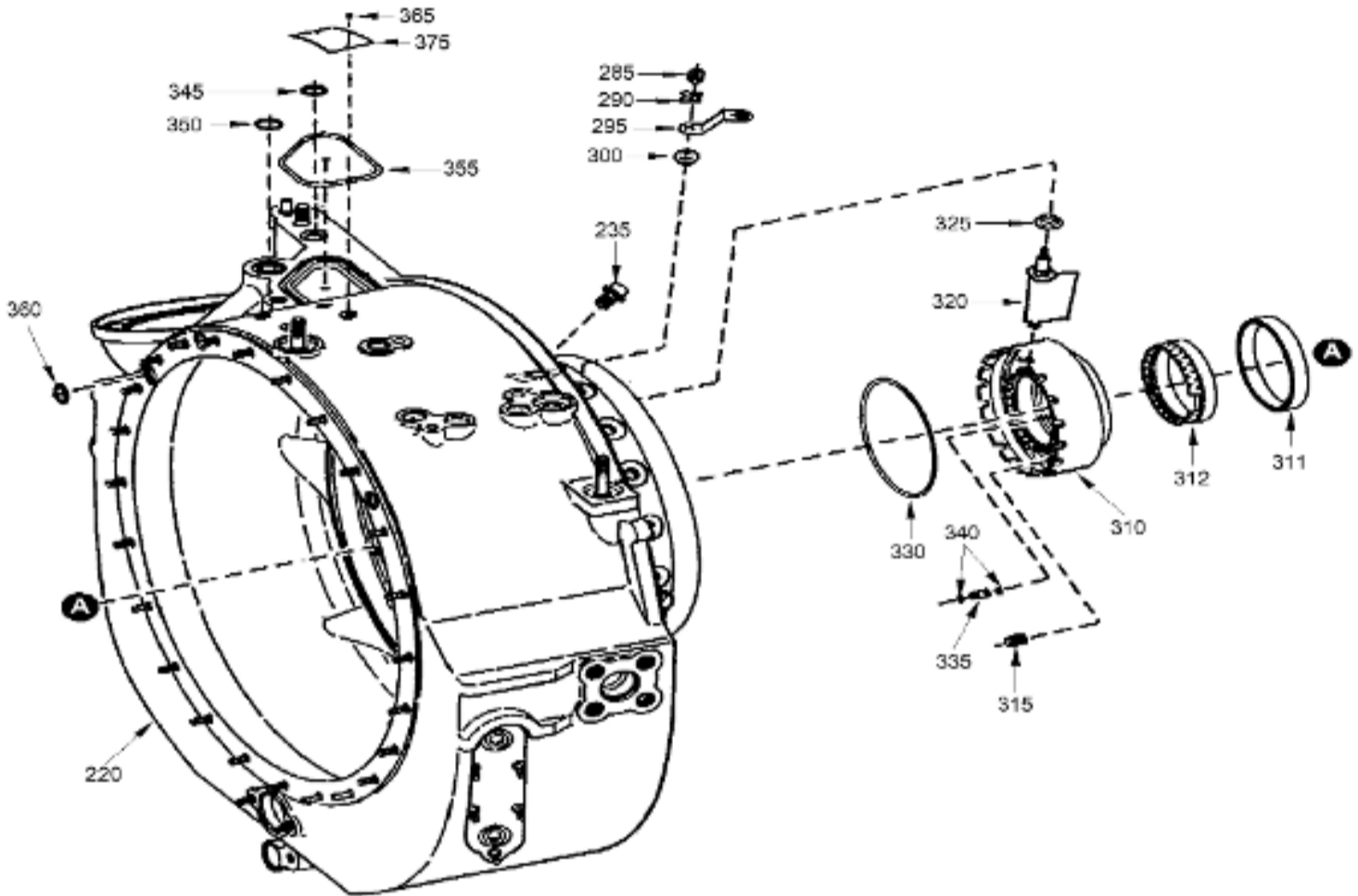
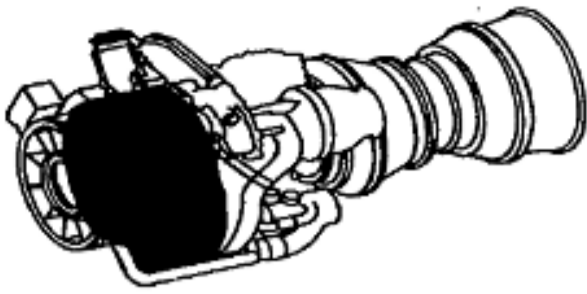

1302961-00

COLD SECTION MODULE
Figure 01 (Sheet 2)

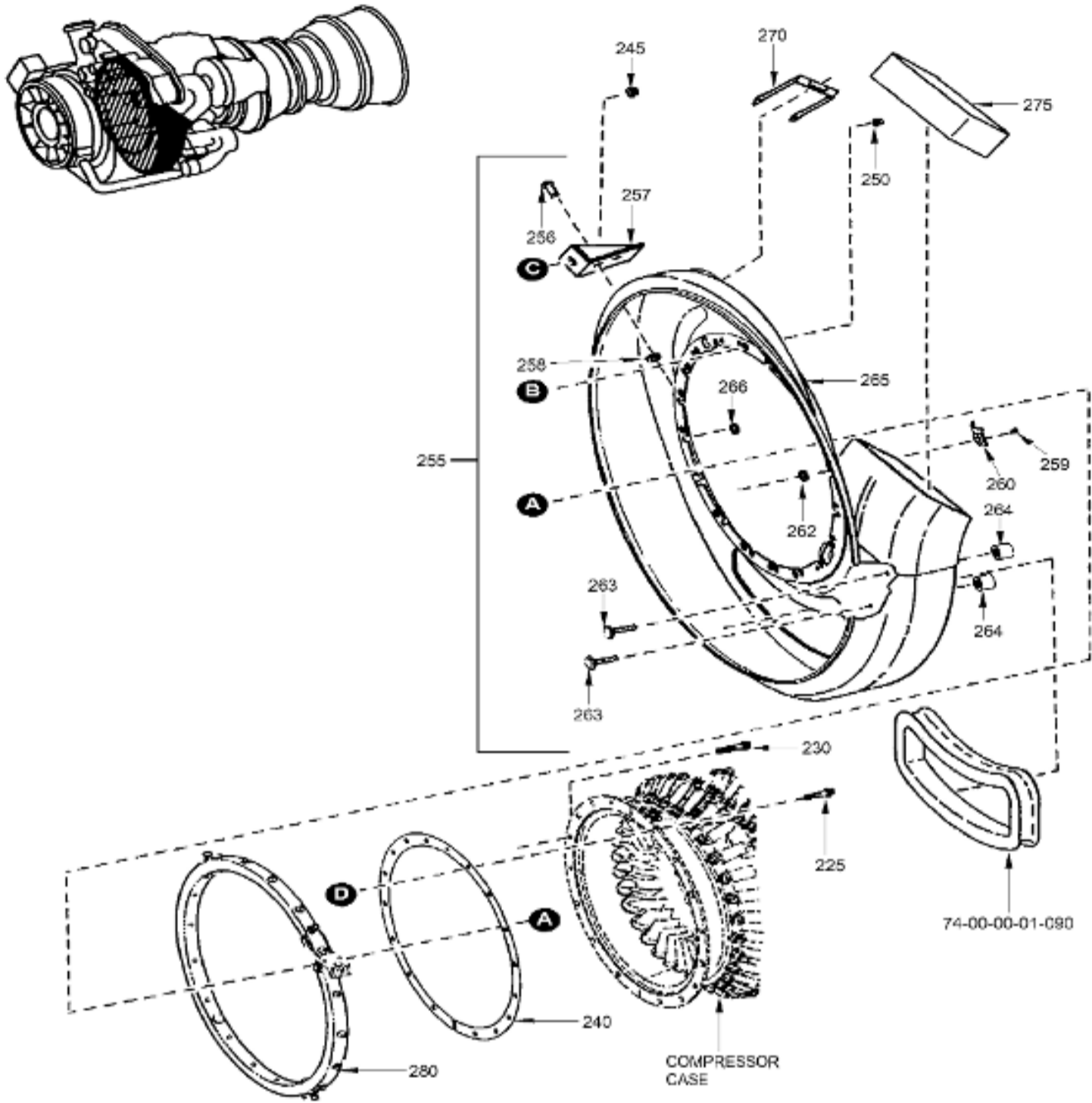

1302962-00

COLD SECTION MODULE
 Figure 01 (Sheet 3)

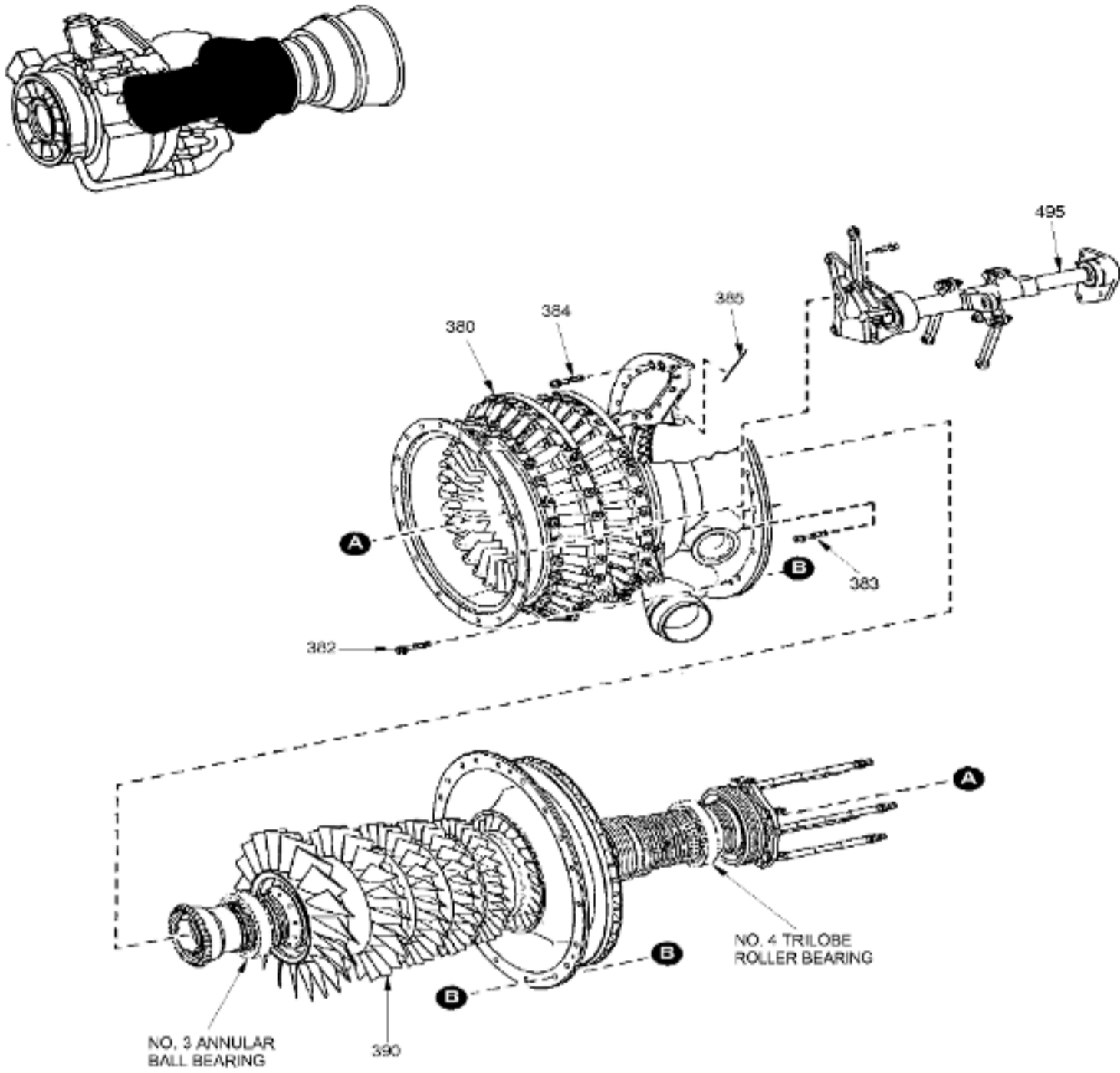

1302963-00

COLD SECTION MODULE
Figure 01 (Sheet 4)

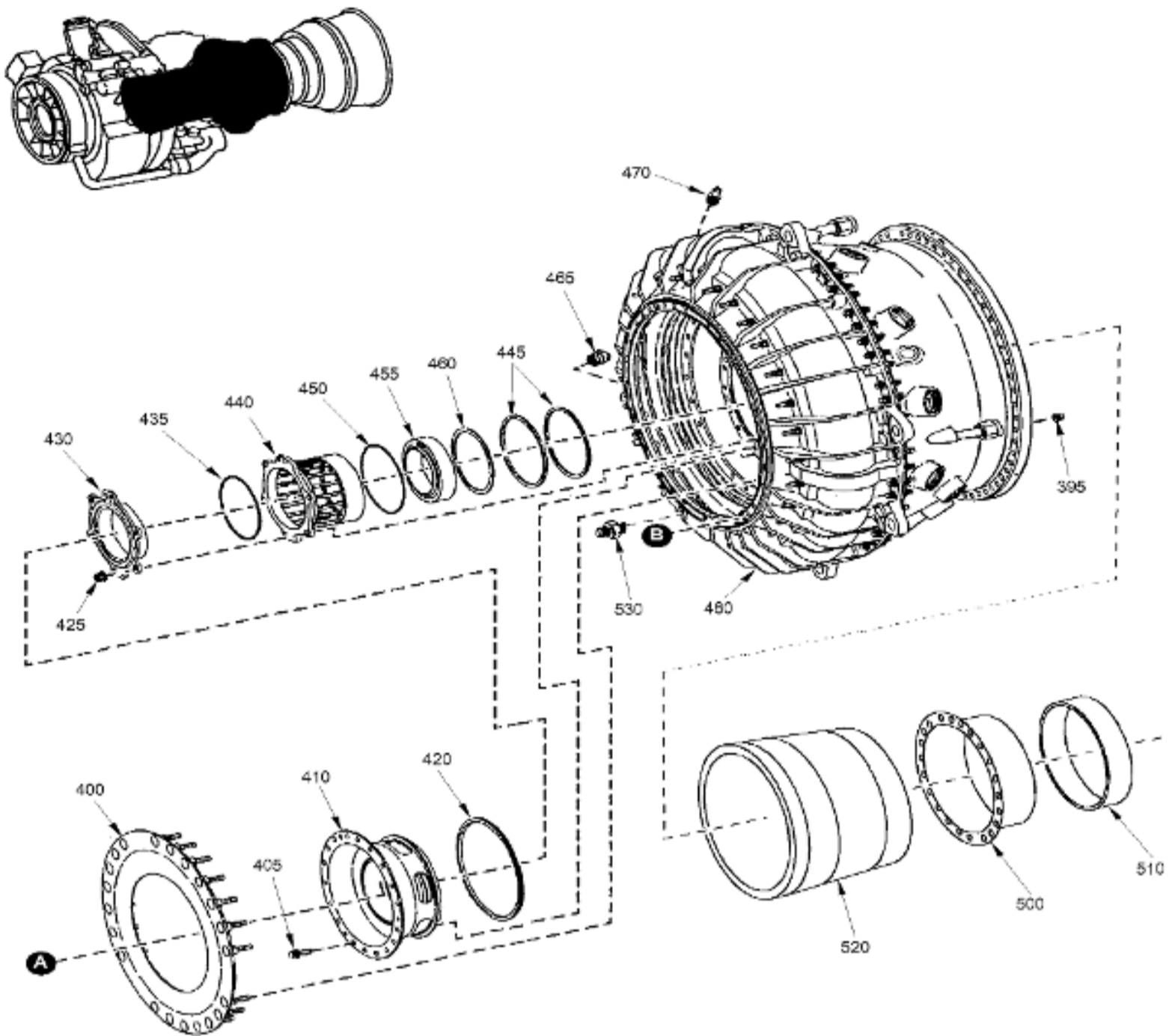

1302964-00

COLD SECTION MODULE
Figure 01 (Sheet 5)

ITEM	PART NUMBER	NOMENCLATURE					USAGE CODE	UNITS PER ASSY
		1	2	3	4	5		
- 001	NHA	COLD SECTION MODULE SIN 00900 SEE 72-00-00-01-160 FOR NHA						RF
- 010	NO-NUMBER	FUEL SYSTEM SEE 73-00-00-01 FOR DET						RF
- 011	NO-NUMBER(2)	ELECTRICAL SYSTEM SEE 74-00-00-01 FOR DET						RF
- 012	NO-NUMBER(3)	AIR SYSTEM SEE 75-00-00-01 FOR DET						RF
- 013	NO-NUMBER(4)	OIL SYSTEM SEE 79-00-00-01 FOR DET						RF
015	J643P06A	. BOLT-MACHINE SIN 0E620 DEL BY SB 72-0013						DEL
020	AN929-5	. CAP ASSY SIN 02290						1

025	AN815-5S	. TUBE-FLARED SIN 02240 REPL BY AS5174R0505	1
-025A	AS5174R0505	. FITTING-FLARED UNION AND REDUCER SIN 02240 POST SB 72-0003 REPLS AN815-5S	1
030	J221P905	. PACKING-PREFORMED SIN 02250	1
040	5153T44P01	. NUT-LOCK SIN 02140	24
-040A	4046T32P02	. NUT-LOCK SIN 02140	ALT
-040B	4046T32P03	. NUT-LOCK SIN 02140	ALT
050	6053T29G01	. SWIRL FRAME-PARTICLE SEPARATOR SIN 02200	1
060	4052T00P02	. . RIVET-FLAT HEAD BLIND SIN 02200 72	8
061	4052T00P02	. . RIVET-FLAT HEAD BLIND SIN 02200 72	6
070	4051T99P01	. . NUT-FLOATING SIN 02200 71	7
075	3036T89P01	. . NUT-SHANK SIN 02200 18	15
-075A	3036T89P02	. . NUT-SHANK SIN 02200 18	ALT
080	MS51830CA201L	. . INSERT-THREADED SIN 02200 38	2
085	6053T29P22	. . SPACER-SLEEVE SIN 02200 44	3
-085A	3904T11P01	. . SLEEVE-SWIRL FRAME (SPAD) POST SB 72-0011	AR
090	3065T21G01	. SHAFT ASSY-A-SUMP OUTPUT SIN 04300 SEE 72-31-00-01 FOR DET SUPSD BY 3065T21G04	1
-090A	3065T21G04	. SHAFT ASSY-A-SUMP OUTPUT SIN 04300 SEE 72-31-00-01 FOR DET POST SB 72-0010 REPL BY 3065T21G06	1
-090B	3065T21G06	. SHAFT ASSY-A-SUMP OUTPUT SIN 04300 SEE 72-31-00-01 FOR DET POST SB 72-0017	1
095	4042T93P01	. NUT-SELF-LOCKING SIN 04340	20
-095A	4042T93P03	. NUT-SELF-LOCKING SIN 04340	ALT
096	R1473P005	. SCREW-MACHINE SIN 04320	2
100	J221P158	. PACKING-PREFORMED SIN 04350	1
105	5056T66G02	. POWER TAKEOFF ASSY SIN 04200 SEE 72-32-00-01 FOR DET	1
110	5153T44P01	. NUT-LOCK SIN 04240	4
-110A	4046T32P02	. NUT-LOCK SIN 04240	ALT
-110B	4046T32P03	. NUT-LOCK SIN 04240	ALT
-110C	4046T32P04	. NUT-LOCK SIN 04240	ALT
115	J643P35A	. BOLT-MACHINE SIN 07220	4
120	5153T44P01	. NUT-LOCK SIN 01340	4
-120A	4046T32P02	. NUT-LOCK SIN 01340	ALT
-120B	4046T32P03	. NUT-LOCK SIN 01340	ALT

-120C	4046T32P04	. NUT-LOCK SIN 01340		ALT
125	5043T91G02	. NOZZLE-PRIME OIL SIN 0130B		1
130	J221P007	. PACKING-PREFORMED SIN 01351		1
135	4040T69P01	. NUT-NO.3 BEARING SELF-LOCKING SIN 01304		1
-135A	4040T69P02	. NUT-NO.3 BEARING SELF-LOCKING SIN 01304		ALT
140	4052T69P01	. SPACER-GEAR-PTO SIN 0130W 0.080-0.085 IN. THK		1
-141	4052T69P02	. SPACER-GEAR-PTO SIN 0130W 0.0683-0.0642 IN. THK		AR
-142	4052T69P03	. SPACER-GEAR-PTO SIN 0130W 0.0628-0.0632 IN. THK		AR
-143	4052T69P04	. SPACER-GEAR-PTO SIN 0130W 0.0618-0.0622 IN. THK		AR
-144	4052T69P05	. SPACER-GEAR-PTO SIN 0130W 0.0608-0.0612 IN. THK		AR
-145	4052T69P06	. SPACER-GEAR-PTO SIN 0130W 0.0598-0.0602 IN. THK		AR
-146	4052T69P07	. SPACER-GEAR-PTO SIN 0130W 0.0588-0.0592 IN. THK		AR
-147	4052T69P08	. SPACER-GEAR-PTO SIN 0130W 0.0578-0.0582 IN. THK		AR
-148	4052T69P09	. SPACER-GEAR-PTO SIN 0130W 0.0568-0.0572 IN. THK		AR
-149	4052T69P10	. SPACER-GEAR-PTO SIN 0130W 0.0558-0.0562 IN. THK		AR
-150	4052T69P11	. SPACER-GEAR-PTO SIN 0130W 0.0548-0.0552 IN. THK		AR
-151	4052T69P12	. SPACER-GEAR-PTO SIN 0130W 0.0538-0.0542 IN. THK		AR
-152	4052T69P13	. SPACER-GEAR-PTO SIN 0130W 0.0528-0.0532 IN. THK		AR
-153	4052T69P14	. SPACER-GEAR-PTO SIN 0130W 0.0518-0.0522 IN. THK		AR
-154	4052T69P15	. SPACER-GEAR-PTO SIN 0130W 0.0508-0.0512 IN. THK		AR
-155	4052T69P16	. SPACER-GEAR-PTO SIN 0130W 0.0498-0.0502 IN. THK		AR
-156	4052T69P17	. SPACER-GEAR-PTO SIN 0130W 0.0640-0.0800 IN. THK		AR
-157	4052T69P18	. SPACER-GEAR-PTO SIN 0130W 0.0488-0.0498 IN. THK		AR
-158	4052T69P19	. SPACER-GEAR-PTO SIN 0130W 0.0478-0.0488 IN. THK		AR
-159	4052T69P20	. SPACER-GEAR-PTO SIN 0130W 0.0468-0.0478 IN. THK		AR
-160	4052T69P21	. SPACER-GEAR-PTO SIN 0130W 0.0458-0.0468 IN. THK		AR
-161	4052T69P22	. SPACER-GEAR-PTO SIN 0130W		AR

		0.0448-0.0458 IN. THK		
-162	4052T69P23	. SPACER-GEAR-PTO SIN 0130W 0.0438-0.0448 IN. THK		AR
170	5153T44P01	. NUT-LOCK SIN 02340		2
-170A	4046T32P02	. NUT-LOCK SIN 02340		ALT
-170B	4046T32P03	. NUT-LOCK SIN 02340		ALT
-170C	4046T32P04	. NUT-LOCK SIN 02340		ALT
175	3036T30P01	. RETAINER-SCAVENGE FORWARD SIN 02301		1
180	3036T31P01	. RETAINER-OIL INLET AND SCAVENGE AFT SIN 02302		1
185	3049T14P01	. TUBE-DISCHARGE SCAVENGE OIL SIN 02201		2
190	4052T95P01	. TUBE-OIL INLET SIN 02202		1
195	J221P013	. PACKING-PREFORMED SIN 02251		4
198	J221P112	. PACKING-PREFORMED SIN 02253		2
200	6039T65G03	. FRAME-PARTICLE SEPARATOR FRONT SIN 02300		1
205	6038T56P01	. SUPPORT-NO.3 BEARING SIN 01301		1
210	6038T48P02	. BEARING-NO.3 BALL SIN 01300		1
-210A	6064T35P01	. BEARING-NO.3 BALL SIN 01300		ALT
-210B	6064T35P02	. BEARING-NO.3 BALL SIN 01300		ALT
215	4041T59P03	. GASKET-POWER TAKE-OFF SIN 02151		1
-215A	4041T59P04	. GASKET-POWER TAKE-OFF SIN 02151		ALT
220	6039T00G05	. FRAME ASSY-MAIN SIN 02100		1
225	J643P10A	. BOLT-MACHINE SIN 07020		13
230	J643P12A	. BOLT-MACHINE SIN 07026		3
235	3032T12P02	. PLUG-BOREScope SIN 02121		1
240	3031T84P04	. SHIM-COMPRESSOR SIN 07070 0.002 IN. THK		AR
-241	3031T84P05	. SHIM-COMPRESSOR SIN 07071 0.005 IN. THK		AR
-242	3031T84P06	. SHIM-COMPRESSOR SIN 07072 0.010 IN. THK		AR
-245	5153T44P01	. NUT-LOCK SIN 02441		3
-245A	4046T32P02	. NUT-LOCK SIN 02441		ALT
-245B	4046T32P03	. NUT-LOCK SIN 02441		ALT
-245C	4046T32P04	. NUT-LOCK SIN 02441		ALT
250	5153T44P01	. NUT-LOCK SIN 02441		17
-250A	4046T32P02	. NUT-LOCK SIN 02441		ALT
-250B	4046T32P03	. NUT-LOCK SIN 02441		ALT
-250C	4046T32P04	. NUT-LOCK SIN 02441		ALT
255	6039T02G01	. SCROLL CASE-PARTICLE SEPARATOR SIN 02400		1
256	MS20426AD4-6	. . RIVET-SOLID		4

		SIN 02400 10		
257	6039T02P09	. . BRACKET SIN 02400 9		2
258	6039T02P14	. . WASHER SIN 02400 17		4
259	NAS1398D4-4	. . RIVET-BLIND SIN 02400 12		2
260	6039T02P10	. . BRACKET SIN 02400 11		1
262	6039T02P14	. . WASHER SIN 02400 17		2
263	6039T02P12	. . STUD SIN 02400 15		2
264	6039T02P11	. . BOSS SIN 02400 14		2
265	6039T02P02	. . SCROLL CASE SIN 02400 2		1
266	6039T02P08	. . BUSHING SIN 02400 8		15
270	4052T90P01	. HANDLE-T2 SENSOR LATCH SIN 02403		1
275	4078T06P01	. BOOT-INLET DUCT SIN 02401		1
280	6039T22G01	. RING-ACTUATING SIN 07202		1
285	3031T29P01	. NUT-SLFLKG SIN 07240		18
- 285A	3031T29P03	. NUT-SLFLKG SIN 07240		ALT
- 285B	3031T29P04	. NUT-SLFLKG SIN 07240		ALT
290	3031T28P01	. WASHER-KEY SIN 07231		18
295	5043T26G01	. LEVER-IGV VANE ACTUATOR SIN 07201		18
300	3031T67P01	. BUSHING-SLEEVE SIN 07204		18
310	6043T59G02	. SUPPORT-IGV - A-SUMP SIN 07203		1
311	6043T59P02	. . HOUSING-SEAL SIN 07203 4		1
- 311A	4902T34P01	. . SEAL-A-SUMP AFT (SPAD) POST SB 72-0011		AR
312	6043T59P04	. . SEAL-FWD A-SUMP SIN 07203 7		1
- 312A	6900T58P01	. . SEAL-A-SUMP FWD (SPAD) POST SB 72-0011		AR
315	5078T02P02	. . INSERT-SCRTHD SIN 07203 5		4
- 315A	5078T02P01	. . INSERT-SCRTHD SIN 07203 5		ALT
320	6043T87G01	. VANE-COMPRESSOR INLET GUIDE SIN 07200		18
325	3033T25P01	. BUSHING-SLEEVE SIN 07205		18
330	J221P154	. PACKING-PREFORMED SIN 01350		1
335	4041T52P01	. TUBE-OIL-EMERG SIN 0130C		1
340	J221P007	. PACKING-PREFORMED SIN 01352		2
345	J221P015	. PACKING-PREFORMED SIN 02155		1
350	J221P114	. PACKING-PREFORMED SIN 02152		1
355	J221P144	. PACKING-PREFORMED SIN 02153		1
360	J221P013	. PACKING-PREFORMED SIN 02252		3
365	AS3568-20	. SCREW-DRIVE SIN 10620		2
375	1022T20P01	. NAMEPLATE		1

		SIN 10600		
380	6039T60G27	. STATOR ASSEMBLY-COMPRESSOR SIN 07000 RWK TO 6039T60G28 SEE 72-36-00-01 FOR DET		1
- 380A	6039T60G28	. STATOR ASSEMBLY-COMPRESSOR SIN 07000 RWK FROM 6039T60G27 POST SB 72-0030 SEE 72-00-00-01 FOR DET		1
382	J644P15A	. BOLT-MACHINE SIN 07024		4
383	J644P14A	. BOLT-MACHINE SIN 07022		7
384	J644P12A	. BOLT-MACHINE SIN 07023		17
385	3036T04P01	. SEAL-PLAIN SIN 07050		2
390	6064T05G09	. ROTOR ASSY-COMPRESSOR SIN 05000 SEE 72-38-00-01 FOR DET		1
395	5153T44P01	. NUT-LOCK SIN 09842		21
400	6053T43G06	. PLATE-SWIRL SIN 09804		1
405	J643P06A	. BOLT-MACHINE SIN 09821		18
410	6071T19G01	. SEAL-COMPRESSOR DISCHARGE AIR SIN 09801		1
- 410A	6071T19G02	. SEAL-COMPRESSOR DISCHARGE AIR SIN 09801		ALT
420	3031T78P01	. SEAL-E SIN 09802		1
425	5153T44P01	. NUT-LOCK SIN 01440		6
- 425A	4046T32P02	. NUT-LOCK SIN 01440		ALT
- 425B	4046T32P03	. NUT-LOCK SIN 01440		ALT
- 425C	4046T32P04	. NUT-LOCK SIN 01440		ALT
430	5044T23G01	. SEAL-NO.4 BEARING FWD OIL SIN 01403		1
435	9169M40P138	. PACKING-PREFORMED SIN 01451		1
440	6035T26P02	. SUPPORT-NO.4 BEARING SIN 01401		1
445	3033T61P02	. RING-PISTON SIN 0140V		2
450	9169M40P140	. PACKING-PREFORMED SIN 01450		1
455	6064T14P01	. BEARING-NO.4 TRILOBE ROLLER SIN 01400		1
- 455A	6064T15P01	. BEARING-NO.4 TRILOBE ROLLER SIN 01400		ALT
- 455B	6064T15P03	. BEARING-NO.4 TRILOBE ROLLER SIN 01400		ALT
460	J206P0287	. RING-RETAINING SIN 01408		1
465	MS21914-4J	. CAP-PRESSURE SEAL SIN 09861		1
- 465A	MS21914-4K	. CAP-PRESSURE SEAL SIN 09861		ALT
- 465B	MS21914-4S	. CAP-PRESSURE SEAL SIN 09861		ALT
470	MS21914-2J	. CAP-PRESSURE SEAL SIN 09860		1
- 470A	MS21914-2K	. CAP-PRESSURE SEAL SIN 09860		ALT
- 470B	MS21914-2S	. CAP-PRESSURE SEAL SIN 09860		ALT
480	6071T55G07	. ASSEMBLY-CASING DIFFUSER AND MIDFRAME SIN 09800		1
495	6039T41G04	. LINKAGE ASSY-ACTUATING SYSTEM		1

		SIN 07100 SEE 72-35-00-01 FOR DET		
500	6071T03G07	. SEAL-OUTER BALANCE PISTON SIN 09805		1
-500A	6071T03G08	. SEAL-OUTER BALANCE PISTON SIN 09805	a	ALT
510	5060T51G01	. . RING SEAL-PISTON SIN 09805 6		1
-510A	5060T51G03	. . RING SEAL-PISTON SIN 09805 6	a	ALT
520	6035T55G01	. SHROUD-INNER COMBUSTOR SIN 09806		1
530	4052T08P01	. FITTING-FUEL DR SIN 0F500		1

- ITEM NOT ILLUSTRATED

GE Designated: - CONFIDENTIAL Subject to the restrictions on the media