

HARTZELL PROPELLER INC.
SERVICE INSTRUCTION
TRANSMITTAL SHEET
HC-SI-61-214

DT-1724-5 Rolling Machine - Packaging Instructions

October 06, 2021

This page transmits a revision to Service Instruction HC-SI-61-214.

- Original Issue, dated Sep 27/19
- Revision 1, dated Nov 01/19
- Revision 2, dated Dec 17/20
- Revision 3, dated Oct 06/21

Changes are shown by a change bar in the left margin of the revised pages.

Revision 3 is issued to change the following in the Service Instruction:

- Revised A-6741-347 Anticorit corrosion inhibitor to corrosion inhibitor CM347 where applicable.

This Service Instruction is reissued in its entirety.

HARTZELL PROPELLER INC.

SERVICE INSTRUCTION

TRANSMITTAL SHEET

HC-SI-61-214

DT-1724-5 Rolling Machine - Packaging Instructions

(This page is intentionally blank.)

HARTZELL PROPELLER INC.
SERVICE INSTRUCTION
HC-SI-61-214

DT-1724-5 Rolling Machine - Packaging Instructions

1. General Information

A. Description

- (1) This Service Instruction provides the procedure for packaging the DT-1724-5 rolling machine for shipment.
- (2) The Appendix of this Service Instruction provides the specifications for the shipping crate (p/n 7810784836) used for the DT-1724-5 rolling machine.

B. Approval

- (1) This technical document is approved by Hartzell Propeller Inc.

CAUTION: DO NOT USE OBSOLETE OR OUTDATED INFORMATION. PERFORM ALL INSPECTIONS OR WORK IN ACCORDANCE WITH THE MOST RECENT REVISION OF A DOCUMENT.

C. References

- (1) Hartzell Propeller Inc. Standard Practices Manual 202A (61-01-02) - Volume 7, Consumable Materials is available on the Hartzell Propeller Inc. website at www.hartzellprop.com

2. Material Information

A. Materials Required for Packaging the DT-1724-5 Rolling Machine

<u>Description</u>	<u>Qty</u>
Shipping crate (p/n 7810784836) - Refer to the Appendix of this Service Instruction for crate specifications	1
Screws, Torx/star drive, #9 x 2-1/2 in. long (T25)	AR
Foam, 1-1/2 in. thick (closed cell polyethylene or equivalent)	AR
Foam, 1/8 in. thick (closed cell polyethylene or equivalent)	AR
Aluminum foil tape CM64 (or equivalent)	AR
Spray Adhesive (Camie 363 or equivalent)	AR
Stretch wrap	AR
Plywood 2 in. x 4 in. x 8 ft. long (IPP compliant)	5
Clear plastic shipping bag, 8-1/2 in. x 11 in.	1

NOTE: All CM numbers in this Service Instruction refer to the Consumable Materials chapter of Hartzell Propeller Inc. Standard Practices Manual 202A (61-01-02).

B. Required Tools

<u>Description</u>
3/16 in. allen wrench
Drill with Torx/star drive bit (T25)
Utility knife

C. Documents Included with Packaging (Hartzell Propeller Inc. only)

<u>Description</u>	<u>Qty</u>
7998-178 DT-1724-5 Automated Rolling Machine Maintenance Manual178 - Contact the Hartzell Technical Publications Department for printed copy.	1
7998-HC-SI-61-213 Uncrating Instructions for the DT-1724-5 Automated Rolling Machine - Contact the Hartzell Technical Publications Department for printed copy.	1
Rolling Machine Certification sheet	1

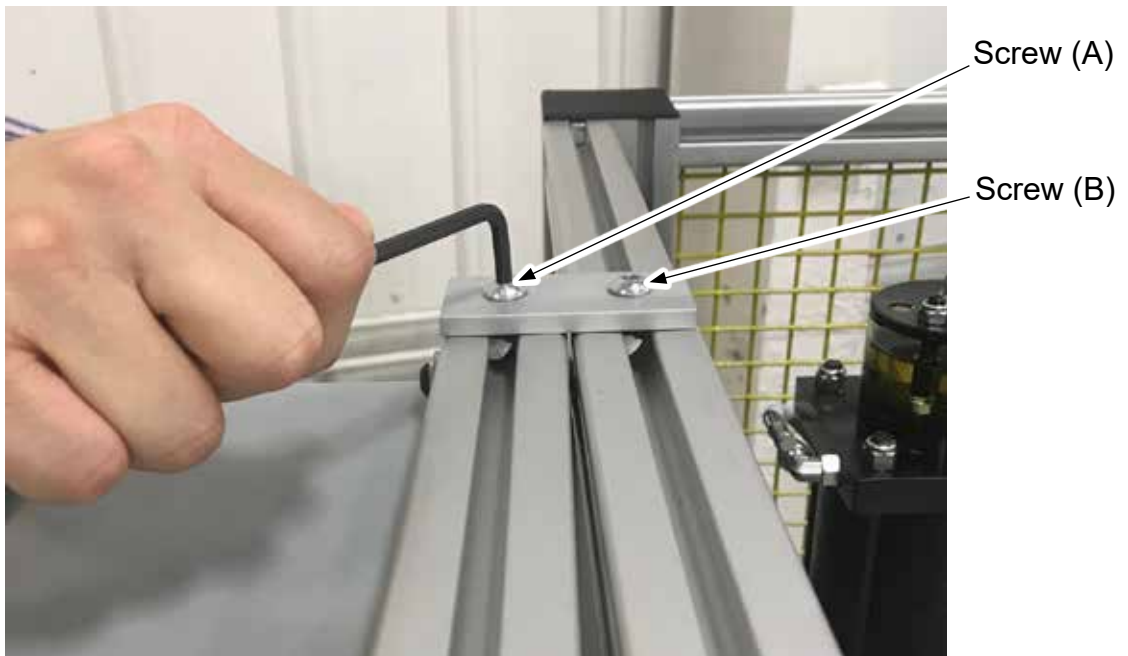
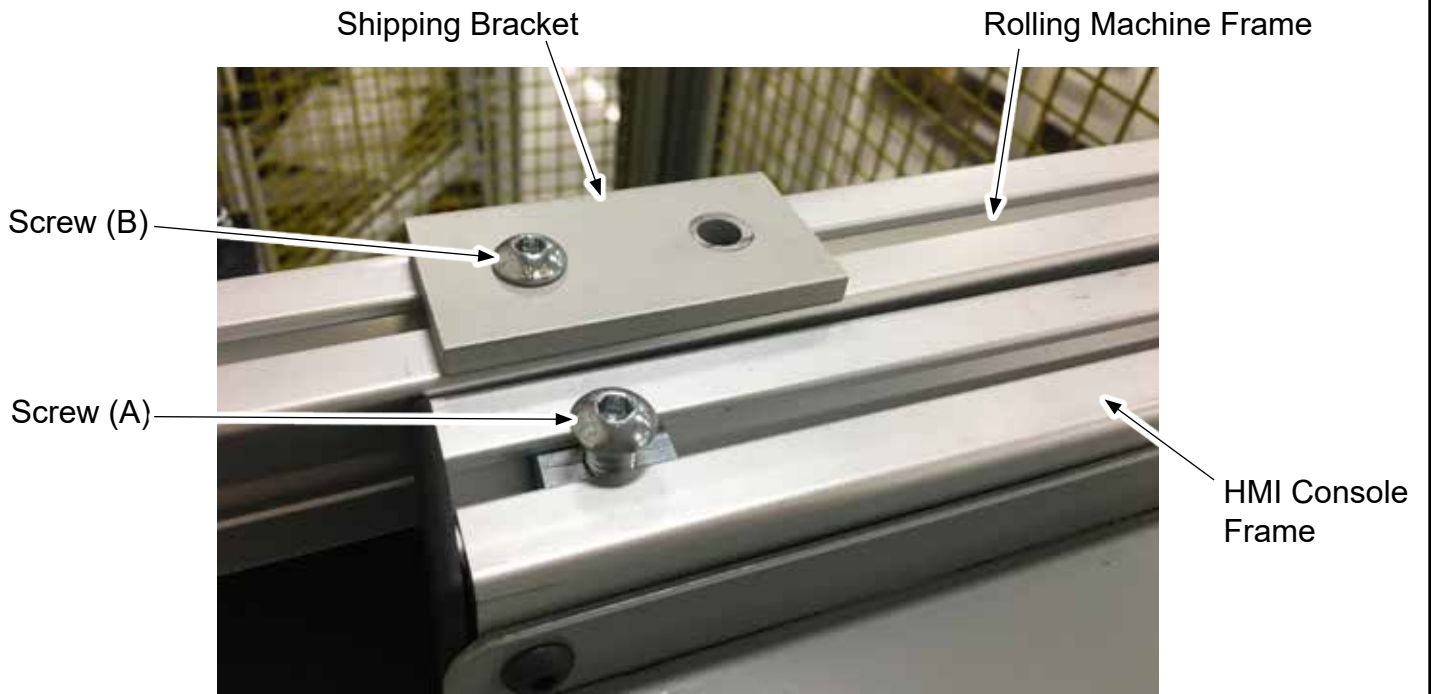

**HMI Console Shipping Bracket
Figure 1**

3. Packaging the DT-1724-5 Rolling Machine for Shipment

A. Prepare the Rolling Machine for Shipment

- (1) Lock the HMI console frame to the rolling machine frame. Refer to Figure 1.
 - (a) Rotate the HMI console frame so that it is parallel to the rolling machine frame.
 - (b) Using a 3/16 inch allen wrench, remove screw (A) from the HMI console frame.
 - (c) Loosen screw (B), then rotate the shipping bracket so that it aligns with the hole in the HMI console frame as shown in Figure 1.
 - (d) Install screw (A) in accordance with Figure 1 to secure the HMI console frame to the rolling machine frame, then tighten screw (B).
- (2) Cover the oil filter hole of the air/oil booster. Refer to Figure 2.
 - (a) Using acetone CM11, clean the area around the oil filter hole of the air/oil booster.
 - (b) Using aluminum foil tape CM64, cover the oil filter hole of the air/oil booster.
 - 1 Make a tab by folding one end of the tape over onto itself.
 - (c) Make sure the tape is secure.



**Covering the Oil Filter Hole
Figure 2**

- (3) Wrap the air/oil booster with a piece of PIGmat or equivalent absorbant material cut to the appropriate size.
 - (a) Secure the PIGmat by wrapping tape completely around the air/oil booster as shown in Figure 3.
 - (b) The PIGmat must completely surround the glass cylinder, including where the glass cylinder base contacts the black booster housing.
 - (c) The PIGmat will minimize the spread of oil that may leak from the air/oil booster.
- (4) Examine all exposed bare steel and black oxide-plated parts/fasteners for a light coating of corrosion inhibitor CM341. Painted metal parts, aluminum parts, and zinc-plated fasteners do not require corrosion inhibitor.

NOTE: In accordance with IM-314, corrosion inhibitor CM341 is applied during the initial machine build, but can get wiped off during the assembly process.

CAUTION: DO NOT SPRAY CORROSION INHIBITOR CM341 DIRECTLY ONTO THE MACHINE PARTS. THIS CAN RESULT IN EXCESSIVE APPLICATION AND/OR DAMAGE TO ELECTRONIC COMPONENTS.

- (a) Using a clean cloth dampened with corrosion inhibitor CM341, wipe any bare steel and/or black oxide-plated parts/fasteners that are not coated.
- (b) Use a clean cloth to remove excess corrosion inhibitor CM341 (pooling, runs, drips, etc.).

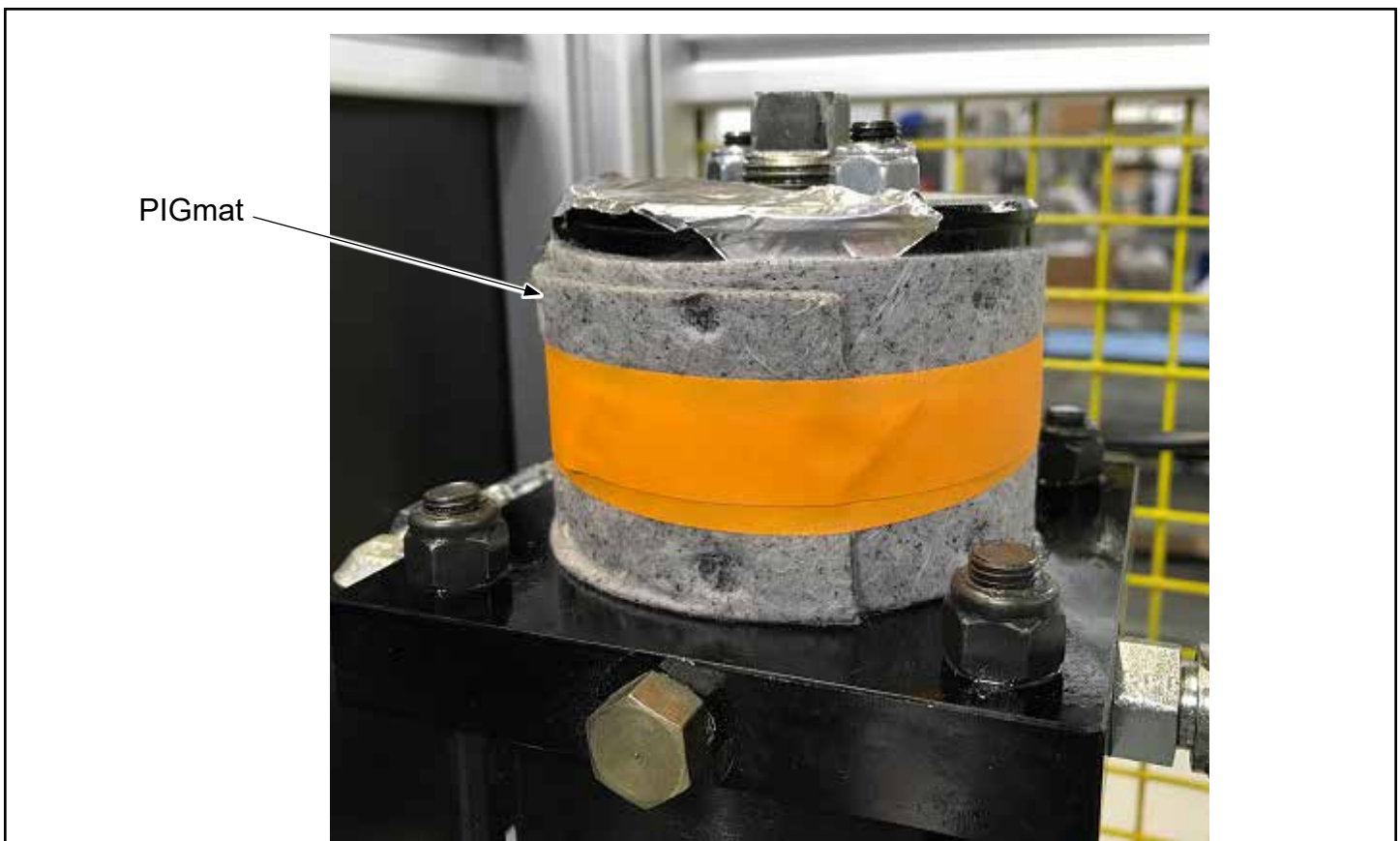

**Wrapping the Air/Oil Booster
Figure 3**



Shipping foam (1/8" thick)



Shrink wrap

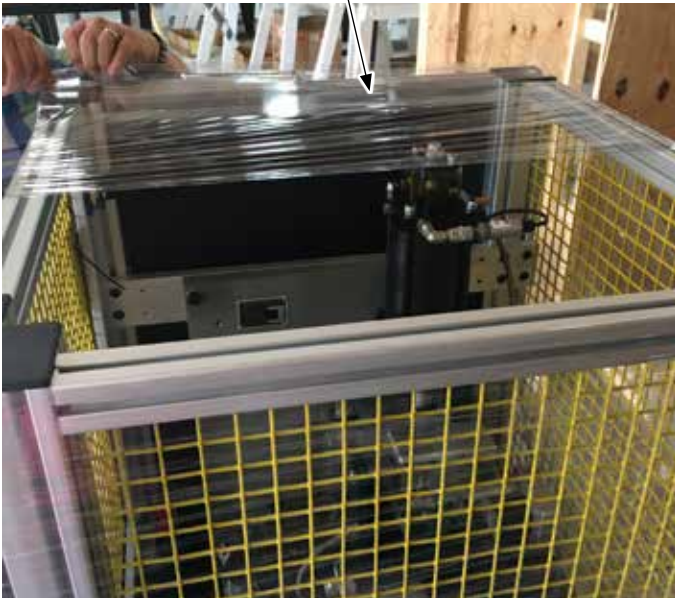

Stretch Wrapping the Rolling Machine
Figure 4

- (5) Stretch wrap the rolling machine. Refer to Figure 4.
 - (a) Wrap 1/8" thick foam around the bottom of the rolling machine as shown in Figure 4.
 - (b) Put the Rolling Machine Certification sheet inside the binder of the 7998-178, "DT-1724-5 Automated Rolling Machine Maintenance Manual 178".
 - (c) Put the 7998-178, "DT-1724-5 Automated Rolling Machine Maintenance Manual 178" in a ziplock bag.
 - 1 Attach the manual to the rolling machine when stretch wrapping.
 - 2 Contact the Hartzell Propeller Inc. Technical Publications Department for a printed copy, if necessary.

CAUTION: TO PREVENT DAMAGE DURING SHIPMENT THE STRETCH WRAP MUST COMPLETELY COVER THE ROLLING MACHINE.

- (d) Starting from the handle, stretch wrap the sides of the rolling machine from top to bottom.
- (e) Put stretch wrap over the top of the rolling machine overlapping the sides as shown in Figure 4.
 - 1 Stretch wrap the sides of the rolling machine again to hold the stretch wrap on top in place.

B. Cut and Install Shipping Braces

- (1) Remove the front panel from the shipping crate (p/n 7810784836).
 - (a) Remove the Torx/star drive screws marked in orange marking paint.
 - (b) Remove the front crate panel.
- (2) Measure and cut the plywood 2 x 4 braces to size.

NOTE: These sizes are approximate. Measure the space before cutting.

Location	Size (Approximate)	Qty.
Top Brace	46-3/8 inches	2
Side Brace	29-1/2 inches	4
Front Brace	45 inches	2
Back Brace	45 inches	2

- (3) Install two back braces [refer to chart in step 3.B.(2)] using Torx/star drive screws through the side panels in accordance with Figure 5 and the following steps:
 - (a) Set the lower back brace on the base of the crate flush against the back panel.
 - (b) Position the upper back brace approximately 36 inches from the bottom of the crate flush against the back panel.
- (4) Remove the back panel from the shipping crate.
- (5) Install two side braces [refer to chart in step 3.B.(2)] to the RH side of the crate in accordance with Figure 5 and the following steps:
 - (a) Set the lower side brace on the base of the crate flush against the back brace.
 - 1 Secure the lower side brace using Torx/star drive screws through the back brace at one end and through the side panel at the other end.
 - (b) Position the upper side brace approximately 36 inches from the bottom of the crate flush against the back brace.
 - 1 Secure the upper side brace using Torx/star drive screws through the back brace at one end and through the side panel at the other end.
- (5) Install the back panel of the crate using enough screws to hold the panel in place temporarily.

NOTE: The back panel will be removed after installing the 1-1/2 inch foam.

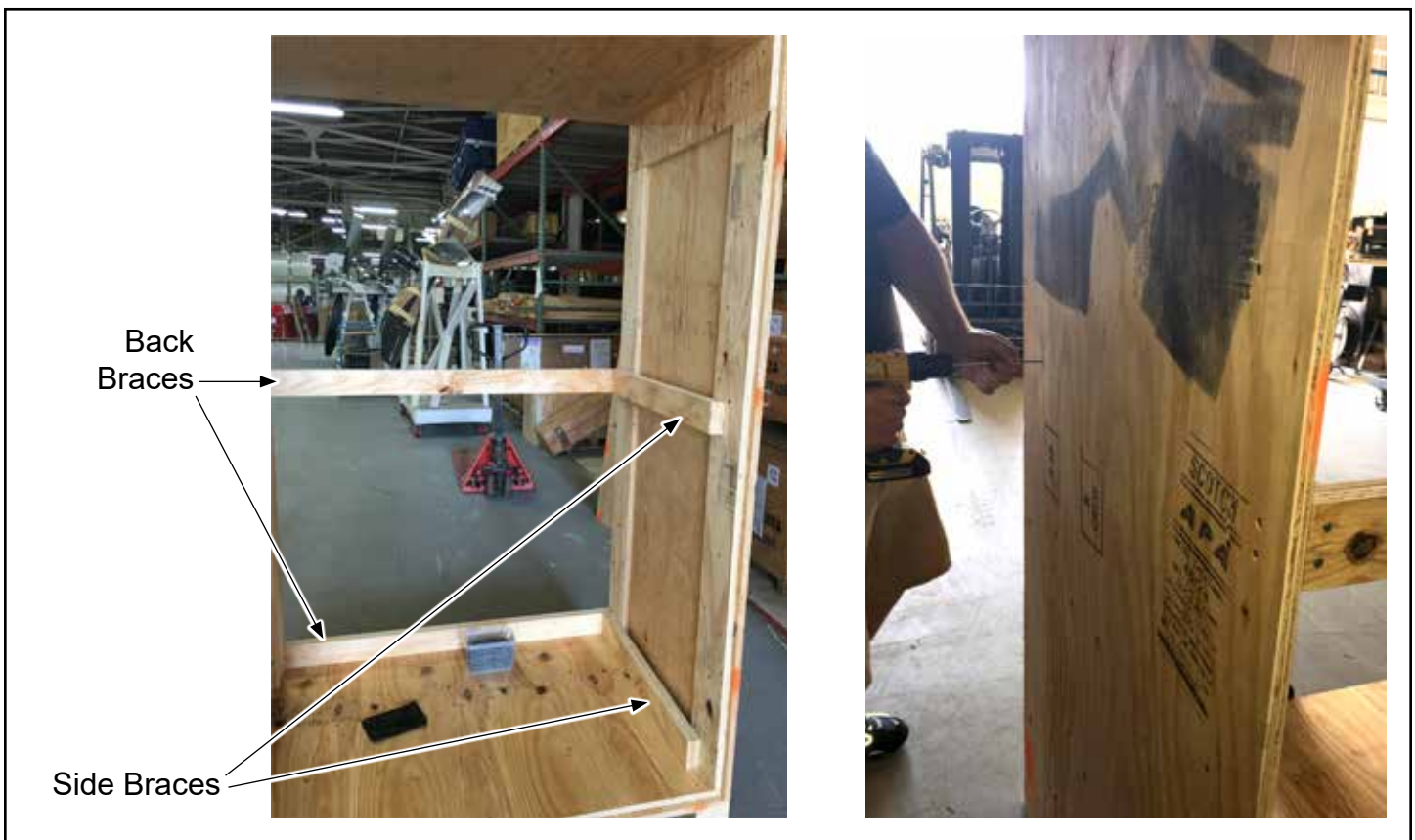

**Back and Side Braces
Figure 5**

- (6) Measure and cut the 1-1/2 inch thick foam to fit the RH side panel of the crate and the upper RH side brace (installed in the crate) in accordance with Figure 6 and the following steps:
- (a) RH Side Panel: Measure the space between the bottom side brace and the upper side brace installed in the crate, then cut 1-1/2 inch thick foam to fit.
 - 1 Optional: Measure the space between the upper side brace and the top of the crate, then cut 1-1/2 inch thick foam to fit.
 - (b) Upper RH Side Brace: Measure the length and width of the upper side brace (installed in the crate) then cut the 1-1/2 inch thick foam to fit.

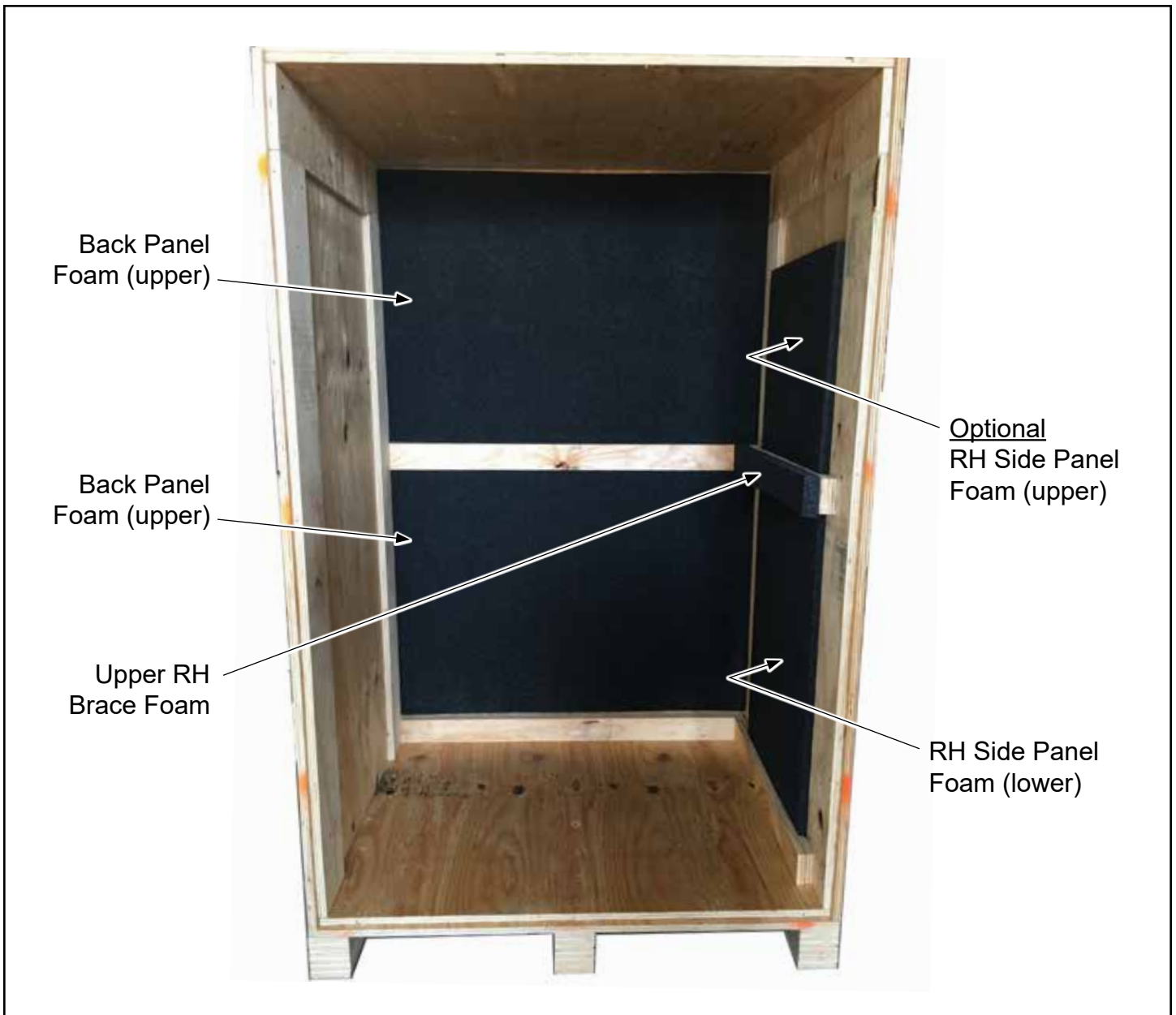

RH Side/Back Panel Foam
Figure 6

- (7) Measure and cut the 1-1/2 inch thick foam to fit the back panel of the crate in accordance with Figure 6 and the following steps:
 - (a) Back Panel (lower): Measure the space between the lower back brace and the upper back brace installed in the crate, then cut 1-1/2 inch thick foam to fit.
 - (b) Back Panel (upper): Measure the space between the upper back brace and the top of the crate, then cut 1-1/2 inch thick foam to fit.
- (8) Attach the 1-1/2 inch foam pieces to the RH side panel, upper RH side brace, and the back panel (upper and lower) using Camie Spray Adhesive 363 or equivalent in accordance with Figure 6, and the following steps:
 - (a) Make sure the foam is clean before applying the spray adhesive.
 - (b) Bond the smooth side of the foam to the plywood.
 - (c) Apply the spray adhesive in accordance with the manufacturer's instructions.
 - (d) Put the foam pieces in the applicable location and apply pressure until bonded.

C. Load the DT-1724-5 Rolling Machine into the Shipping Crate (p/n 7810784836)

WARNING: THE DT-1724-5 ROLLING MACHINE WEIGHS APPROXIMATELY 700 LBS.

CAUTION 1: USING A HOIST WITH STRAPS MAY DAMAGE CAGE OF THE ROLLING MACHINE.

CAUTION 2: LOAD THE ROLLING MACHINE INTO THE SHIPPING CRATE SO THAT THE HMI CONSOLE IS ON THE LEFT SIDE OF THE CRATE AS SHOWN IN FIGURE 7.

NOTE 1: Hartzell Propeller Inc. recommends using a tow motor to move the DT-1724-5 rolling machine.

NOTE 2: Lift the DT-1724-5 rolling machine from the bottom to prevent damage.

- (1) Remove the back panel of the crate.

- (2) Load the rolling machine into the crate.
 - (a) If using a tow motor, put the tow motor forks under the rolling machine from the front and make sure there is no interference with the forks.
 - 1 Lift the rolling machine up slowly.
 - CAUTION:** MAKE SURE THE ROLLING MACHINE STAYS ON THE TOW MOTOR FORKS WHEN LOADING INTO THE CRATE.
 - 2 Carefully move the rolling machine into the crate until the back of the rolling machine is against the lower back brace as shown in Figure 7.
- (3) Measure and cut the 1-1/2 inch thick foam to fit two LH side braces, two front braces, and two top braces [refer to chart in step 3.B.(2) for brace sizes] in accordance with the following steps:
 - (a) LH Side Braces: Measure the length and width of the LH side braces, then cut the 1-1/2 inch thick foam to fit.
 - (b) Front Braces: Cut two pieces of 1-1/2 inch thick foam 27 inches long then trim to fit the width of the front braces.
 - (c) Top Braces: Measure the length and width of the top braces, then cut the 1-1/2 inch thick foam to fit.



Back Brace (lower)

**Loading the Rolling Machine into the Shipping Crate
Figure 7**



**Front Brace - Lower
Figure 8**



**Front Brace - Upper
Figure 9**

- (4) Mark the foam location on the front braces in accordance with the following steps:
- (a) Front Brace (lower): Set the front brace on the base of the crate against the lower RH side brace (attached to the crate) as shown in Figure 8.
 - 1 Make two marks on the front brace to indicate the location of the rolling machine.
 - a When attaching the 1-1/2 inch foam, position it between the two marks.
 - (b) Front Brace (upper): Hold the front brace against upper RH side brace (attached to the crate) as shown in Figure 9.
 - 1 Make two marks on the front brace to indicate the location of the rolling machine.
 - a When attaching the 1-1/2 inch foam, position it between the two marks.
- (5) Attach the 1-1/2 inch foam pieces to the two LH side braces, and the two front braces (upper and lower) using Camie Spray Adhesive 363 or equivalent in accordance with Figure 8, Figure 9, and the following steps:
- (a) Make sure the foam is clean before applying the spray adhesive.
 - (b) Bond the smooth side of the foam to the plywood.
 - (c) Apply the spray adhesive in accordance with the manufacturer's instructions.
 - (d) Put the foam pieces in the applicable location and apply pressure until bonded.

- (6) Install the lower front brace and the lower LH side brace in accordance with the following steps:
- (a) Put the lower front brace on the base of the crate against the lower RH side brace (attached to the crate) as shown in Figure 8.
 - (b) Put the lower LH side brace on the base of the crate against the rolling machine between the lower front/back braces as shown in Figure 10.
 - (c) Using Torx/star drive screws through the lower front brace, attach the RH side of the lower front brace to the lower RH side brace (attached to the crate).
 - (d) Using Torx/star drive screws through the side panel of the crate, attach the LH side of the lower front brace to the side panel.
 - (e) Using Torx/star drive screws through the lower front/back braces, attach the lower LH side brace to the lower front/back braces.

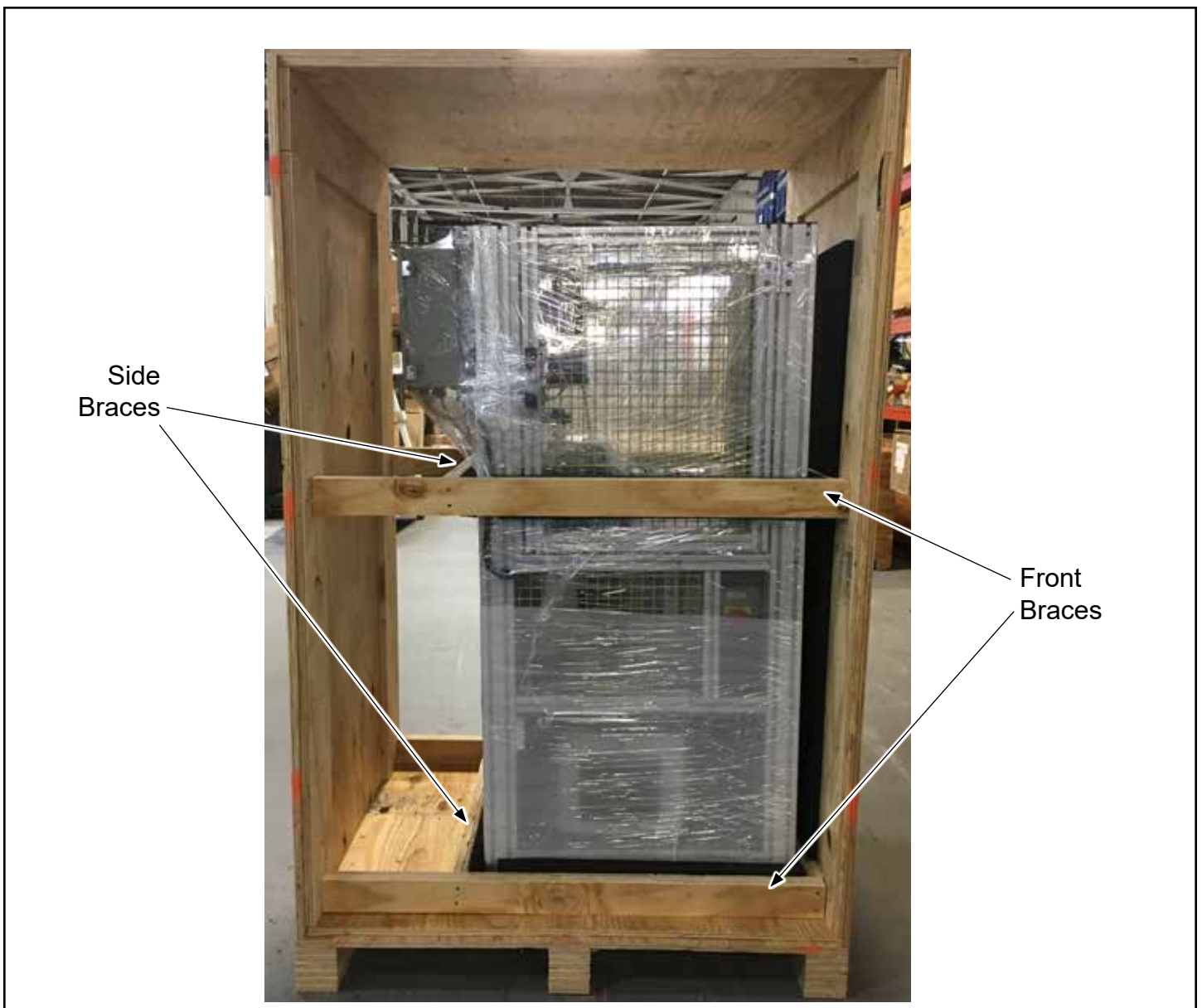

Front/Side Braces
Figure 10

- (7) Install the upper front brace and the upper LH side brace in accordance with the following steps:
 - (a) Put the upper front brace against the upper RH side brace (attached to the crate) as shown in Figure 9.
 - (b) Using Torx/star drive screws through the upper front brace, attach the RH side of the upper front brace to the upper RH side brace (attached to the crate).
 - (c) Using Torx/star drive screws through the side panel of the crate, attach the LH side of the upper front brace to the side panel.
 - (d) Put the upper LH side brace against the rolling machine between the upper front/back braces as shown in Figure 10.
 - (e) Using Torx/star drive screws through the upper front/back braces, attach the upper LH side brace to the upper front/back braces.
- (8) Install the front/back top braces in accordance with Figure 11 and the following steps:
 - (a) Put top braces on top of the rolling machine as shown in Figure 11.

NOTE: Figure 11 shows the back top brace. The installation process for the front top brace is the same.



**Top Braces
Figure 11**

- (b) Push down on the top brace until it is snug against the rolling machine, then using Torx/star drive screws through the side panels of the crate, attach the top brace to the side panels of the crate.
- (9) Using Torx/star drive screws, attach the back panel of the crate.
- (10) Using Torx/star drive screws, attach the front panel of the crate.
- (11) Put one 7998-HC-SI-61-213, Uncrating Instructions for the Hartzell Propeller Inc. DT-1724-5 Automated Rolling Machine into a clear plastic shipping bag.

NOTE: Contact the Technical Publications Department for a printed copy, if necessary.

- (12) Attach the clear plastic bag to the front of the crate.
- (13) Attach a “This Side Up” label to the front and back of the crate.
- (14) Attach a “Fragile” label to the front and back of the crate.

4. Contact Information

Hartzell Propeller Inc.
Attn.: Hartzell Propeller Inc. Product Support
One Propeller Place
Piqua, Ohio 45356-2634 USA
Phone: (001) 937.778.4379
Fax: (001) 937.778.4215
E-mail: techsupport@hartzellprop.com

HARTZELL PROPELLER INC.
SERVICE INSTRUCTION APPENDIX
HC-SI-61-214
Shipping Crate (p/n 7810784836) Specifications

1. General Information

A. Description

- (1) This Appendix provides specifications for the shipping crate (p/n 7810784836) used for the DT-1724-5 rolling machine.

2. Material Information

A. Shipping Crate (p/n 7810784836) Materials

<u>Description</u>	<u>Qty</u>
4 ft. x. 8 ft. sheets of 3/4 in. plywood (IPP compliant)	7
3-1/2 in. x 4-1/2 in. plywood blocks, 36 in. long (IPP compliant)	3
Screws, Torx/star drive, #8 x 1-1/4 in. long (T17)	AR
Screws, Torx/star drive, #9 x 2-1/2 in. long (T25)	AR
Framing nails (optional - for base assembly only)	AR
Paint (orange)	AR

Rolling Machine Crate (p/n 7810784836) Base Assembly

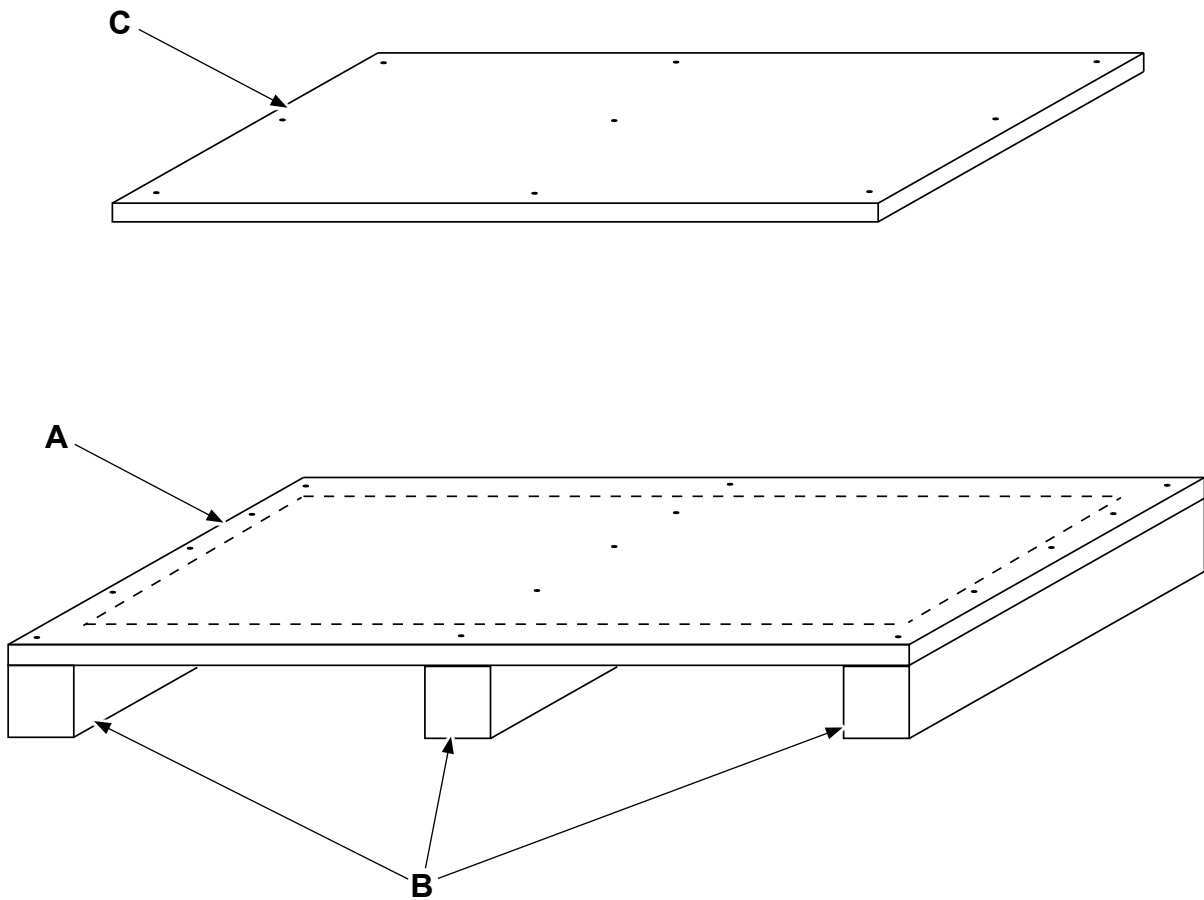

TPI-MB-0391

Callout	Specifications	Qty.	Instructions
A	3/4" plywood, 48 in. x 36 in.	1	-
B	3-1/2 in. x 4-1/2 in. plywood blocks, 36 in. long	3	Attach three (B) pieces to (A) as shown, using evenly spaced framing nails or screws.
C	3/4" plywood, 46-1/2 in. x 34-1/2 in.	1	Position (C) on (A) with a 3/4" gap on each side, then attach (C) to (A) using evenly spaced framing nails or screws.

Rolling Machine Crate (p/n 7810784836)

Side Panel Assembly

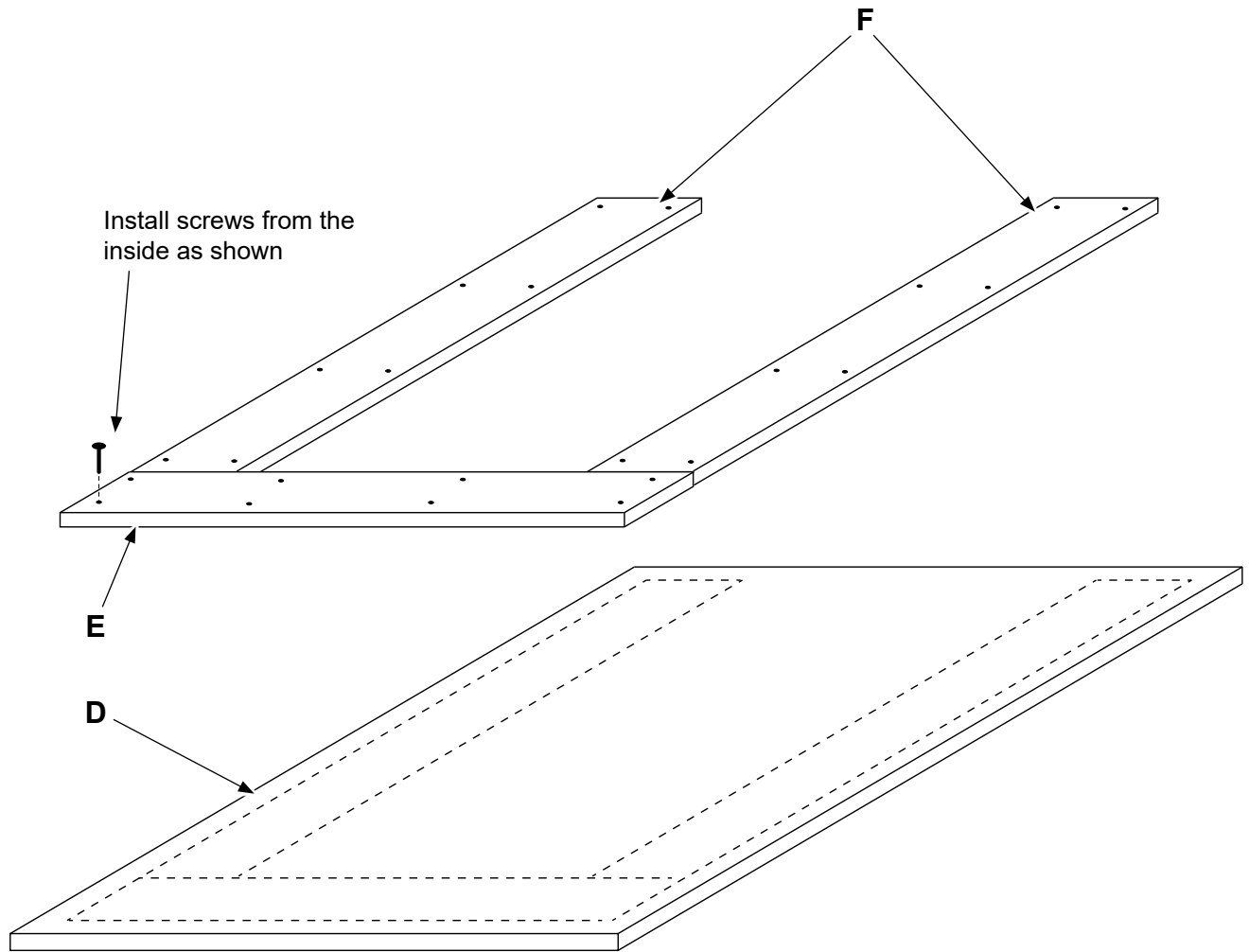

TPI-MB-0392

Callout	Specifications	Qty.	Instructions
D	3/4" plywood, 36 in. x 72 in.	2	-
E	3/4" plywood, 34-1/2 in. x 6 in.	2	Position (E) on (D) with a 3/4" gap on each side and a 3/4" gap at the top edge as shown, then attach (E) to (D) using evenly spaced 1-1/4" Torx/star drive screws. Repeat for the other side panel (D).
F	3/4" plywood, 64-1/2 in. x 6"	4	Position two (F) pieces on (D) with the top edge against (E) and a 3/4" gap on the outside edge as shown, then attach two (F) pieces to (D) using evenly spaced 1-1/4" Torx/star drive screws. Repeat for the other side panel (D).

Rolling Machine Crate (p/n 7810784836)

Top Panel Assembly

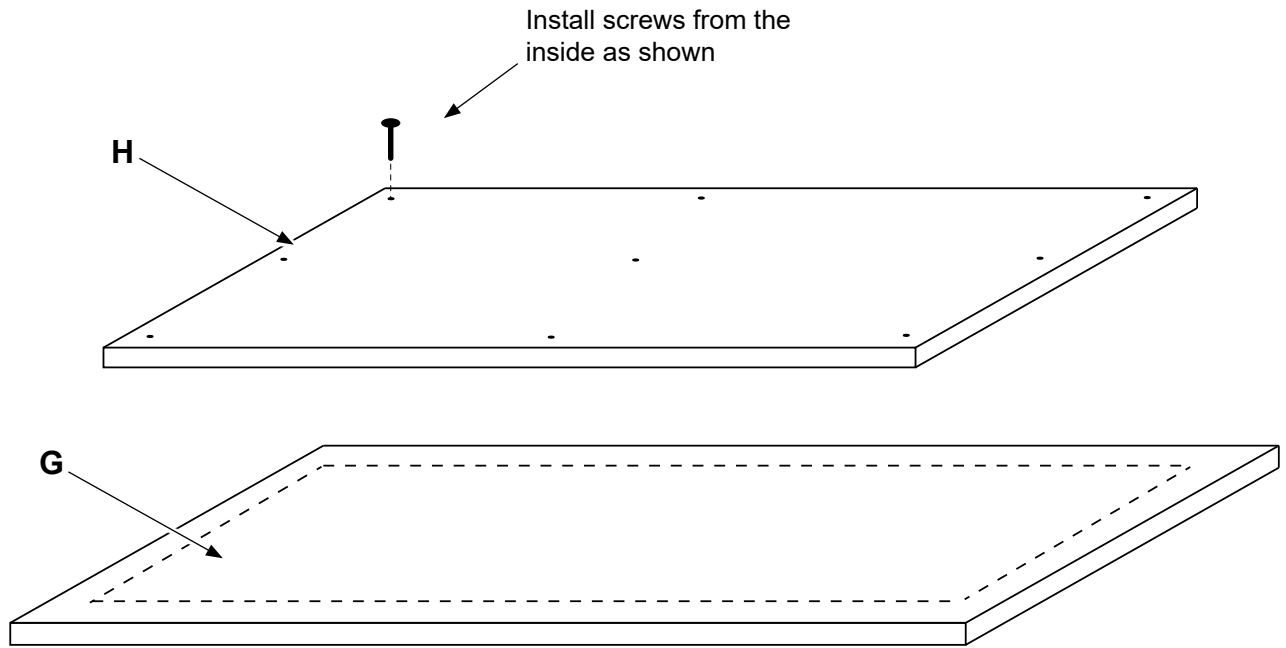

TPI-MB-0393

Callout	Specifications	Qty.	Instructions
G	3/4" plywood, 48 in. x 34-1/2 in.	1	-
H	3/4" plywood, 46-1/2 in. x 34-1/2 in.	2	Position (H) on (G) with a 3/4" gap on each side as shown, then attach (H) to (G) using evenly spaced 1-1/4" Torx/star drive screws.

Rolling Machine Crate (p/n 7810784836)

Side/Top Panel Installation

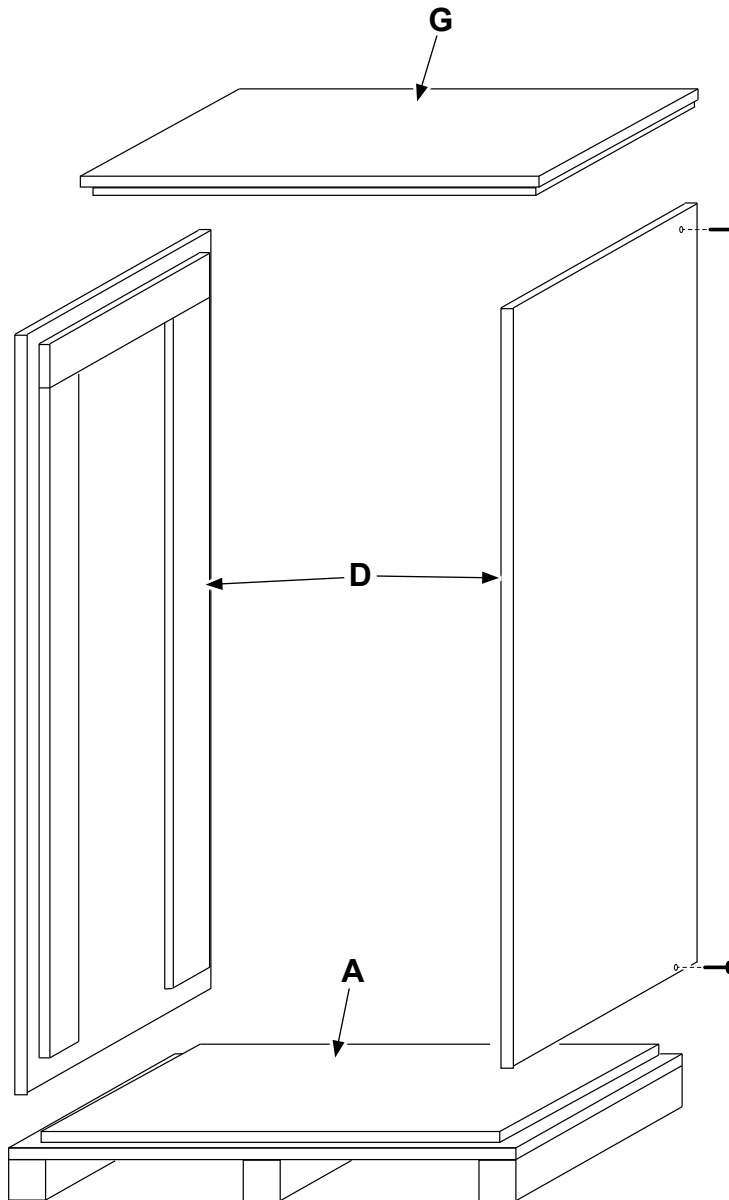

Use bright colored paint to highlight location of the screws attaching the side/top panels.

TPI-MB-0394

Callout	Specifications	Qty.	Instructions
A	Refer to the "Base Assembly" page of this document	1	-
D	Refer to the "Side Panel Assembly" page of this document	2	Set the bottom of side panel (D) on base (A) and align the edges. Attach (D) to (A) using evenly spaced 2-1/2" Torx/star drive screws. Repeat for the other side panel (D).
G	Refer to the "Top Panel Assembly" page of this document	1	Position the top panel (G) on top of the side panels (D) as shown, then attach (G) to (D) using evenly spaced 2-1/2" Torx/star drive screws.

Rolling Machine Crate (p/n 7810784836)

Front/Back Panels

Use bright colored paint to highlight location of the screws attaching the front/back panels.

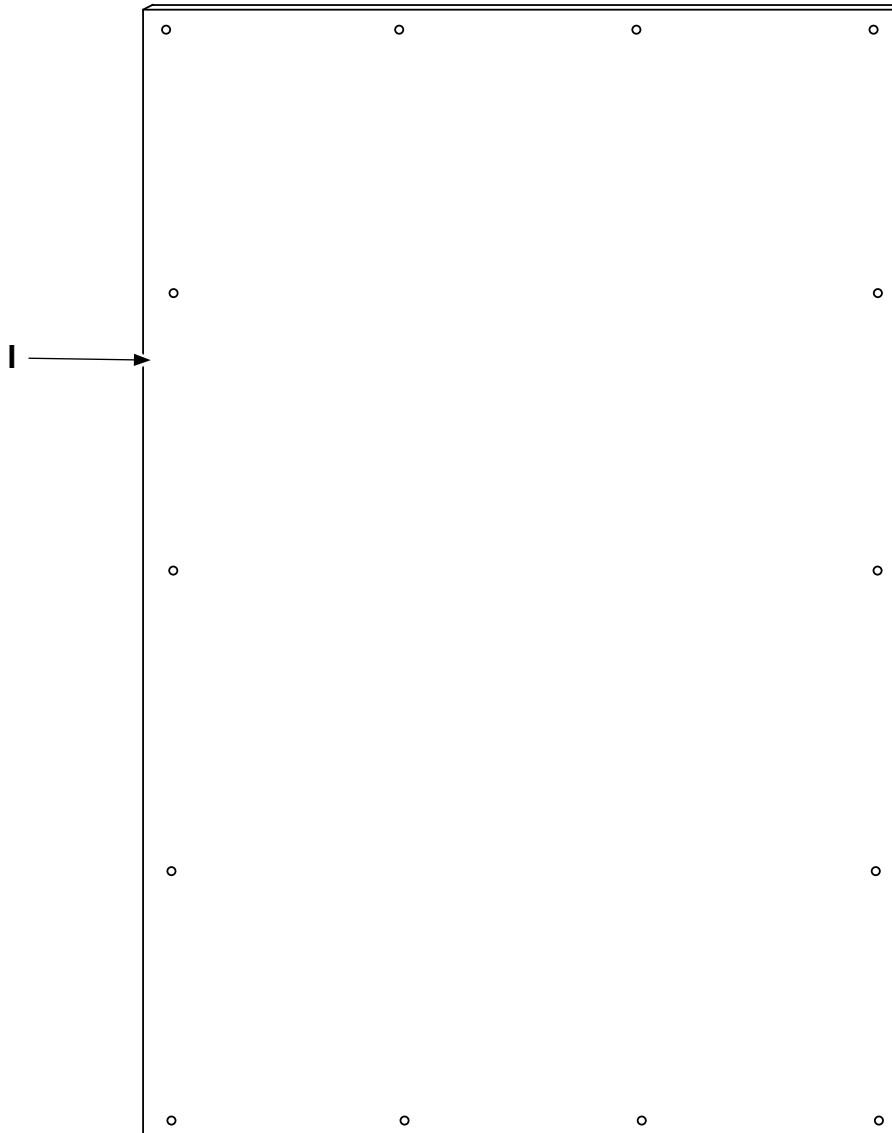

TP1-MB-0395

Callout	Specifications	Qty.	Instructions
I	3/4" plywood, 46-1/2 in. x 73 in.	2	Position the front/back panels (I) between the side panels (D), then attach front/back panels (I) to the side panels (D), top panel (G), and base (A) using evenly spaced 2-1/2" Torx/star drive screws.

Rolling Machine Crate (p/n 7810784836)
Outside Dimensions

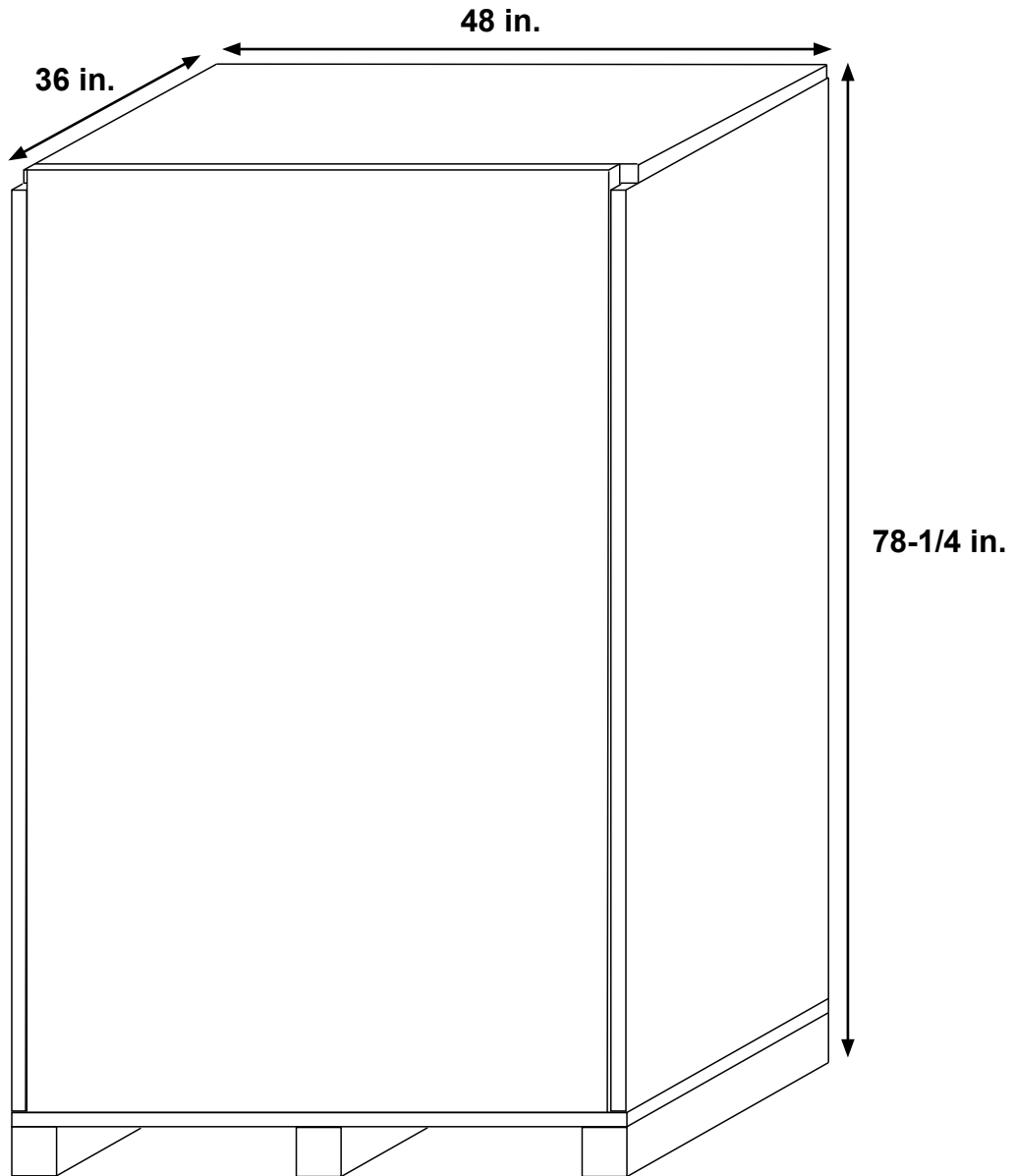

NOTE: Tolerance for the outside dimensions is $\pm 1/4$ inch

TPI-MB-0396

(This page is intentionally blank.)