

HARTZELL PROPELLER INC.
SERVICE BULLETIN
TRANSMITTAL SHEET
HC-SB-61-392

108298 Cylinder Bushing and 108346 Hub Bushing

July 07, 2021

This page transmits a revision to Service Bulletin HC-SB-61-392.

- Original Issue, dated Apr 05/21
- Revision 1, dated Jul 07/21

Propeller assemblies that have already complied with the cylinder/hub bushing replacement in the previous revision of this Service Bulletin are not affected.

Changes are shown by a change bar in the left margin of the revised pages.

Revision 1 is issued to change the following in the Service Bulletin:

- Revised the section, "Reason"
- Revised the section, "Description"
- Revised the section, "Material Information"
- Revised the section, "Cylinder Leak Check Procedure" and Figure 6
- Revised the section, "108346 Hub Bushing Installation"
- Added the section, "Hub Modification" and Figure 9

This Service Bulletin is reissued in its entirety.

HARTZELL PROPELLER INC.
SERVICE BULLETIN
TRANSMITTAL SHEET
HC-SB-61-392

108298 Cylinder Bushing and 108346 Hub Bushing

(This page is intentionally blank.)

HARTZELL PROPELLER INC.
SERVICE BULLETIN
HC-SB-61-392

108298 Cylinder Bushing and 108346 Hub Bushing

1. Planning Information

A. Effectivity

- (1) Hartzell Propeller Inc. lightweight turbine propeller models HC-E5A-(2,3,31)(), HC-E5B-5(), HC-E5N-(3,5)(), HC-E5(P,W)-3(), are affected by this Service Bulletin.

WARNING: DO NOT USE OBSOLETE OR OUTDATED INFORMATION. PERFORM ALL INSPECTIONS OR WORK IN ACCORDANCE WITH THE MOST RECENT REVISION OF THIS SERVICE BULLETIN. INFORMATION CONTAINED IN THIS SERVICE BULLETIN MAY BE SIGNIFICANTLY CHANGED FROM EARLIER REVISIONS. FAILURE TO COMPLY WITH THIS SERVICE BULLETIN OR THE USE OF OBSOLETE INFORMATION MAY CREATE AN UNSAFE CONDITION THAT MAY RESULT IN DEATH, SERIOUS BODILY INJURY, AND/OR SUBSTANTIAL PROPERTY DAMAGE. REFER TO THE SERVICE BULLETIN INDEX FOR THE MOST RECENT REVISION LEVEL OF THIS SERVICE BULLETIN.

B. Concurrent Requirements

- (1) Additional service documents may apply to the components/propellers affected by this Service Bulletin. Compliance with additional service documents may be necessary in conjunction with the completion of the Accomplishment Instructions in this Service Bulletin. Refer to the Hartzell Propeller Inc. website at www.hartzellprop.com for a cross-reference of service documents.

C. Reason

- (1) Hartzell Propeller Inc. has received reports of oil leaking at the A-3784 cylinder bushing on affected propellers.
 - (a) Hartzell is introducing the 108298 cylinder bushing as a replacement for the A-3784 cylinder bushing on affected propellers.
 - 1 The 108298 cylinder bushing has a machined O-ring groove on the OD of the bushing. This provides a more consistent seal between the bushing and the cylinder to prevent oil leaks. Refer to Figure 1.

HARTZELL PROPELLER INC.
SERVICE BULLETIN

HC-SB-61-392

108298 Cylinder Bushing and 108346 Hub Bushing

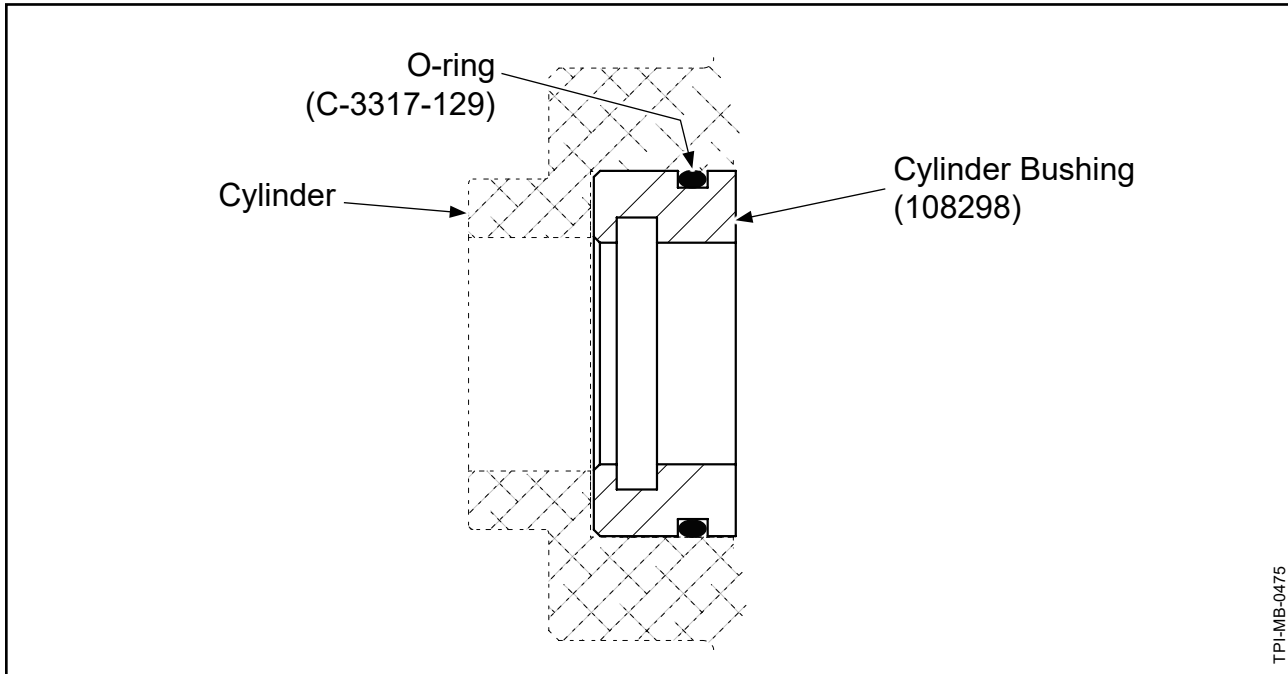

**108298 Cylinder Bushing
Figure 1**

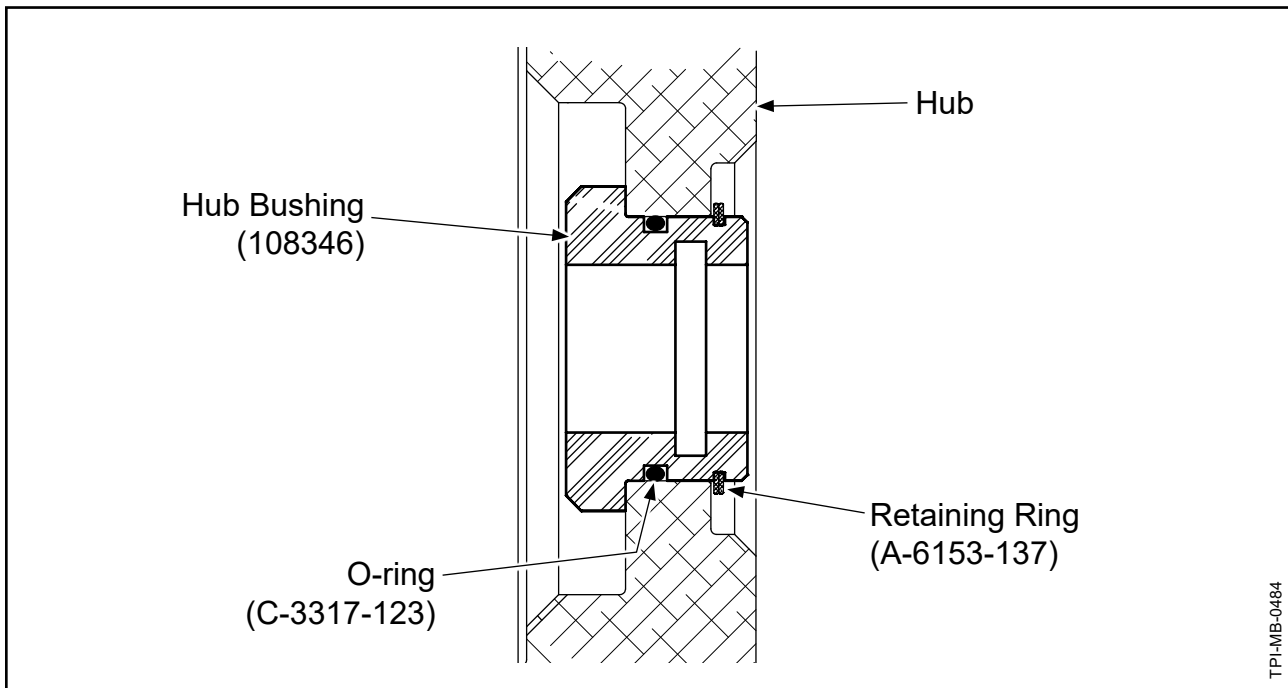

**108346 Hub Bushing
Figure 2**

HARTZELL PROPELLER INC.
SERVICE BULLETIN
HC-SB-61-392

108298 Cylinder Bushing and 108346 Hub Bushing

- (2) Hartzell Propeller Inc. has received reports of oil leaking at the hub bushing [p/n 104903 or A-3789()] on affected propellers.
 - (a) Hartzell is introducing the 108346 hub bushing as a replacement for the 104903 and A-3789() hub bushings on affected propellers.
 - 1 The 108346 hub bushing has a larger O-ring groove on the OD of the bushing.
 - 2 The larger O-ring (p/n C-3317-123) used with the 108346 hub bushing provides a more consistent seal between the bushing and the hub to prevent oil leaks. Refer to Figure 2.

D. Description

- (1) This Service Bulletin provides Instructions for Continued Airworthiness (ICA).
- (2) This Service Bulletin introduces the 108298 cylinder bushing as a replacement for the A-3784 cylinder bushing on affected propellers.
 - (a) Affected propellers manufactured by Hartzell after the release date of this Service Bulletin will incorporate the 108298 cylinder bushing.
 - (b) Existing inventory of A-3784 cylinder bushings must be discarded.
- (3) This Service Bulletin introduces the 108346 hub bushing and C-3317-123 O-ring as replacements for the 104903 hub bushing and C-3317-026-2 O-ring used on affected propellers.
 - (a) Affected propellers manufactured by Hartzell after the release date of this Service Bulletin will incorporate the 108346 hub bushing and C-3317-123 O-ring.
 - (b) Existing inventory of 104903 hub bushings must be discarded.
- (4) This Service Bulletin provides inspection criteria for the cylinders used on the affected propellers.
- (5) This Service Bulletin provides inspection criteria for the 108298 cylinder bushing.
- (6) This Service Bulletin provides installation instructions for the 108298 cylinder bushing.
 - (a) This Service Bulletin provides instructions for a cylinder pressure check that must be performed after installing the 108298 cylinder bushing.

HARTZELL PROPELLER INC.
SERVICE BULLETIN
HC-SB-61-392

108298 Cylinder Bushing and 108346 Hub Bushing

- (7) This Service Bulletin provides inspection criteria for the 108346 hub bushing.
- (8) This Service Bulletin provides installation instructions for the 108346 hub bushing.
- (9) Revision 1 of this Service Bulletin incorporates the hub modification instructions from Harzell Propeller Inc. Service Bulletin HC-SB-61-345 and Service Letter HC-SL-61-339.
 - (a) Hub assemblies that have an A-3789() hub bushing bonded into the hub must be modified in accordance with the "Hub Modification" section in this Service Bulletin before installing the 108346 hub bushing.
 - (b) Harzell Propeller Inc. Service Bulletin HC-SB-61-345 and Service Letter HC-SL-61-339 will be obsolete after the release date of this Service Bulletin (HC-SB-61-392, Rev. 1).

E. Compliance

NOTE: Overhaul intervals are specified in Hartzell Propeller Inc. Service Letter HC-SL-61-61Y.

- (1) At next propeller overhaul or major disassembly, whichever occurs first, remove the A-3784 cylinder bushing and install a 108298 cylinder bushing in accordance with the Accomplishment Instructions section in this Service Bulletin.
 - (a) When inspection is required, inspect the cylinder and the 108298 cylinder bushing in accordance with the Accomplishment Instructions section in this Service Bulletin.
- (2) At next propeller overhaul or major disassembly, whichever occurs first, remove the 104903 or A-3789() hub bushing and install a 108346 hub bushing and C-3317-123 O-ring in accordance with the Accomplishment Instructions section in this Service Bulletin.
 - (a) When inspection is required, inspect the 108346 hub bushing in accordance with the Accomplishment Instructions section in this Service Bulletin.

HARTZELL PROPELLER INC.
SERVICE BULLETIN
HC-SB-61-392

108298 Cylinder Bushing and 108346 Hub Bushing

F. Approval

- (1) FAA acceptance has been obtained on technical data in this publication that affects type design.

G. Manpower

- (1) No additional man-hours required when performed at overhaul.

H. Weight and Balance

- (1) Not changed

I. Electrical Load Data

- (1) Not changed

**CAUTION: DO NOT USE OBSOLETE OR OUTDATED INFORMATION.
PERFORM ALL INSPECTIONS OR WORK IN ACCORDANCE WITH
THE MOST RECENT REVISION OF A DOCUMENT.**

J. References

- (1) Hartzell Propeller Inc. Five Blade Lightweight Turbine Propeller Overhaul Manual 157 (61-10-57)
- (2) Hartzell Propeller Inc. Five Blade Lightweight Turbine Propeller Overhaul Manual 158A (61-10-58)

K. Other Publications Affected

- (1) Hartzell Propeller Inc. Five Blade Lightweight Turbine Propeller Overhaul Manual 157 (61-10-57)
- (2) Hartzell Propeller Inc. Five Blade Lightweight Turbine Propeller Overhaul Manual 158A (61-10-58)
- (3) Hartzell Propeller Inc. Service Bulletin HC-SB-61-345 (obsolete)
- (4) Hartzell Propeller Inc. Service Letter HC-SL-61-339 (obsolete)

HARTZELL PROPELLER INC.
SERVICE BULLETIN
HC-SB-61-392

108298 Cylinder Bushing and 108346 Hub Bushing

2. Material Information

A. Component Cross Reference

Part Number	Description	Replaces:
108298	Bushing, Cylinder	A-3784
108346	Hub Bushing	104903 or A-3789()*
B-7418-1	Bumper	B-7418*
C-3317-123	O-ring	C-3317-026-2

* Used with D-7432 hub assembly only.
The D-7432 hub assembly must be modified in accordance with this Service Bulletin before installing the 108346 hub bushing.

B. Special Tooling

TE Number	Description
TE436-2	Profilometer
TE652-1	Cylinder Leak Check Fixture (5.1250-20 UNS thread)
TE652-2	Cylinder Leak Check Fixture (5.8750-20 UNS thread)

NOTE: All TE numbers in this Service Bulletin refer to Hartzell Propeller Inc. Tool and Equipment Manual 165A (61-00-65).

HARTZELL PROPELLER INC.
SERVICE BULLETIN
HC-SB-61-392

108298 Cylinder Bushing and 108346 Hub Bushing

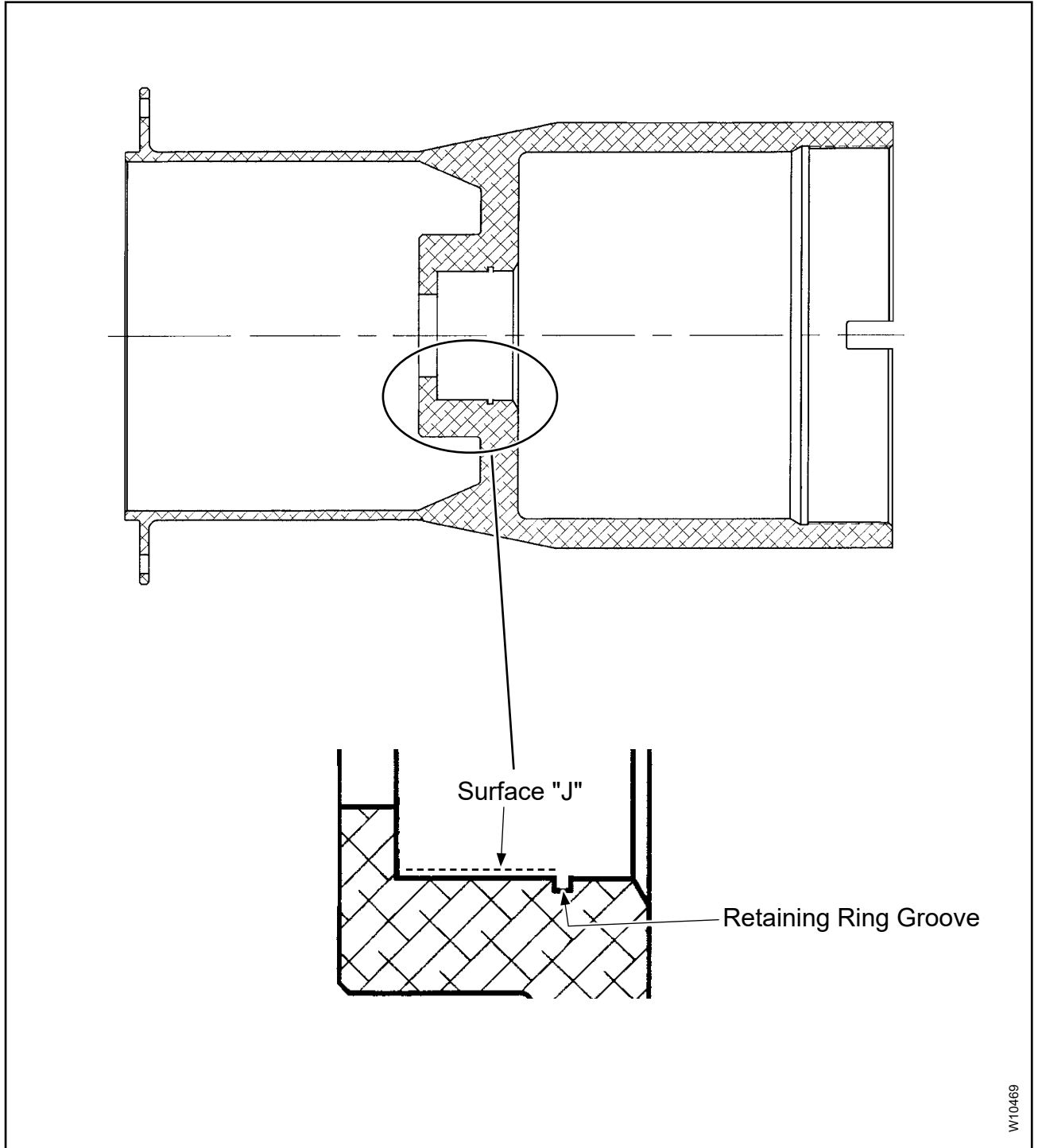

Cylinder Inspection: Surface "J"
Figure 3

HARTZELL PROPELLER INC.
SERVICE BULLETIN
HC-SB-61-392

108298 Cylinder Bushing and 108346 Hub Bushing

3. Accomplishment Instructions

CAUTION: INSTRUCTIONS AND PROCEDURES IN THIS SERVICE BULLETIN MAY INVOLVE PROPELLER CRITICAL PARTS. REFER TO THE APPLICABLE PROPELLER OVERHAUL OR OWNER'S MANUAL FOR INFORMATION ABOUT PROPELLER CRITICAL PARTS.

A. Cylinder Inspection Criteria

- (1) Inspect the cylinder in the affected propeller in accordance with the Check chapter of the applicable Hartzell Propeller Inc. overhaul manual, **except:**
 - (a) Inspect Surface "J" of the cylinder in accordance with Table 1 and Figure 3 in this Service Bulletin.

Inspect	Serviceable Limits	Corrective Action
<u>CYLINDER (Surface "J")</u> (Refer to Figure 3)		
(1) Using a Profilometer TE436-2 or equivalent, examine the finish on Surface "J".	The maximum permitted surface finish is 32Ra.	If the surface finish is greater than the permitted serviceable limits, polish Surface "J" using 3M microfinishing film (373L), or equivalent. The maximum permitted diameter of Surface "J" after repair is 1.7560 inch (44.602 mm).

Cylinder Inspection Criteria: Surface "J"
Table 1

HARTZELL PROPELLER INC.
SERVICE BULLETIN
HC-SB-61-392

108298 Cylinder Bushing and 108346 Hub Bushing

B. 108298 Cylinder Bushing Inspection Criteria

- (1) Inspect the 108298 cylinder bushing in accordance with Table 2 and Figure 4 in this Service Bulletin.

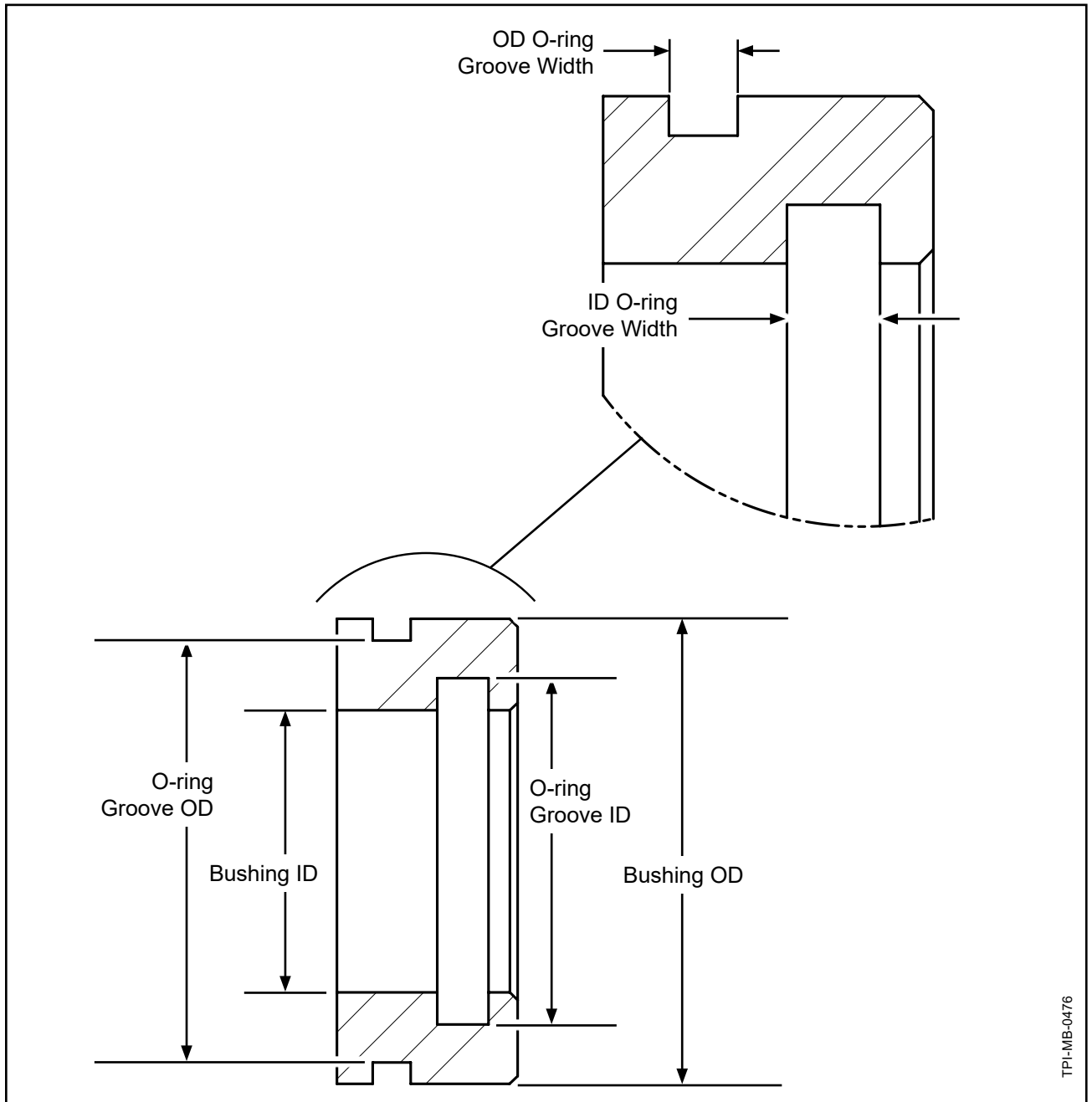

**108298 Cylinder Bushing Inspection
Figure 4**

HARTZELL PROPELLER INC.
SERVICE BULLETIN
HC-SB-61-392

108298 Cylinder Bushing and 108346 Hub Bushing

Inspect	Serviceable Limits	Corrective Action
<u>108298 CYLINDER BUSHING</u>		
(Refer to Figure 4)		
(1) Visually examine both sides of the cylinder bushing for wear, damage, and distortion.	Wear, damage, or distortion is not permitted.	If there is wear, damage, or distortion, replace the cylinder bushing.
(2) Measure the cylinder bushing OD.	The minimum permitted bushing OD is 1.750 inches (44.45 mm).	If the bushing OD is less than the permitted serviceable limit, replace the cylinder bushing.
(3) Measure the cylinder bushing ID and examine the surface finish.	The maximum permitted ID is 1.064 inches (27.02 mm). A smooth surface is required.	If the bushing ID is greater than the permitted serviceable limit, or if the surface finish is not smooth, replace the cylinder bushing.
(4) Measure the cylinder bushing O-ring groove ID and examine the surface finish.	The maximum permitted O-ring groove ID is 1.306 inches (33.17 mm). A smooth surface is required.	If the O-ring groove ID is greater than the permitted serviceable limit, or if the surface finish is not smooth, replace the cylinder bushing.
(5) Measure the cylinder bushing O-ring groove OD and examine the surface finish.	The minimum permitted O-ring groove OD is 1.586 inches (40.29 mm). A smooth surface is required.	If the O-ring groove OD is less than the permitted serviceable limit, or if the surface finish is not smooth, replace the cylinder bushing.
(6) Measure the width of the ID O-ring groove and examine the groove for wear, damage, and distortion.	The maximum permitted width of the ID O-ring groove is 0.170 inch (4.31 mm). Wear, damage, or distortion is not permitted.	If the width of the ID O-ring groove is greater than the permitted serviceable limit, or if there is wear, damage, or distortion, replace the the cylinder bushing.
(7) Measure the width of the OD O-ring groove and examine the groove for wear, damage, and distortion.	The maximum permitted width of the OD O-ring groove is 0.146 inch (3.70 mm). Wear, damage, or distortion is not permitted.	If the width of the OD O-ring groove is greater than the permitted serviceable limit, or if there is wear, damage, or distortion, replace the the cylinder bushing.

**108298 Cylinder Bushing Inspection Criteria
Table 2**

HARTZELL PROPELLER INC.
SERVICE BULLETIN
HC-SB-61-392

108298 Cylinder Bushing and 108346 Hub Bushing

C. 108298 Cylinder Bushing Installation

- (1) Remove/disassemble the propeller in accordance with the Disassembly chapter in the applicable Hartzell Propeller Inc. overhaul manual, **except**:
 - (a) Remove and discard the cylinder bushing (A-3784) and the O-ring (C-3317-129).
- (2) Before installing the 108298 cylinder bushing, inspect the cylinder in accordance with the section, "Cylinder Inspection Criteria" in this Service Bulletin.
- (3) Apply grease CM12 to the O-ring (C-3317-129).
 - (a) Install the O-ring (C-3317-129) in the O-ring groove on the OD of the cylinder bushing (108298).
- (4) Apply grease CM12 to the bore of the cylinder.
- (5) Position the cylinder bushing (108298) with the O-ring (C-3317-129) closest to the retaining ring groove as shown in Figure 5, then press the cylinder bushing into the bore of the cylinder.
 - (a) Install the retaining ring (B-6629-175PP) in the retaining ring groove of the cylinder to retain the cylinder bushing (108298).
- (6) Perform the Cylinder Leak Check Procedure in accordance with the instructions in this Service Bulletin.

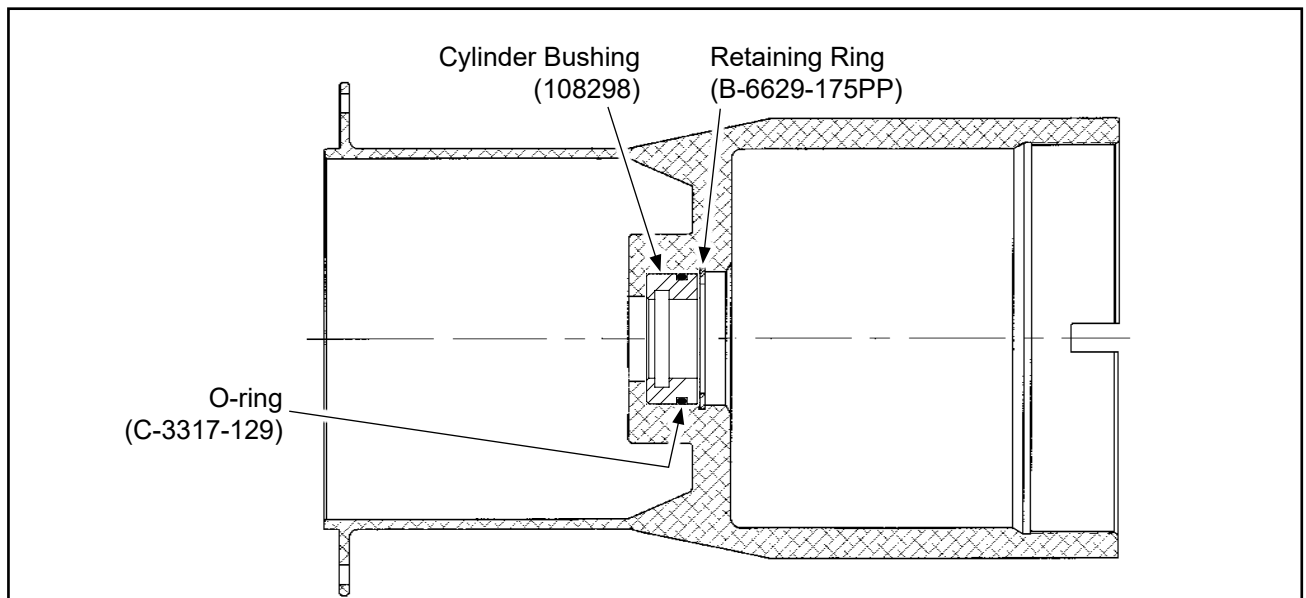

108298 Cylinder Bushing Installation

Figure 5

HARTZELL PROPELLER INC.
SERVICE BULLETIN
HC-SB-61-392

108298 Cylinder Bushing and 108346 Hub Bushing

D. Cylinder Leak Check Procedure (Refer to Figure 6)

- (1) Inspect the O-rings on the cylinder leak check fixture TE652().
 - (a) Install a new or serviceable C-3317-215-() O-ring in the groove on the ID of the 108346 hub bushing.
 - (b) All surfaces of the fixture, including the threads must be clean and free of nicks and scratches.

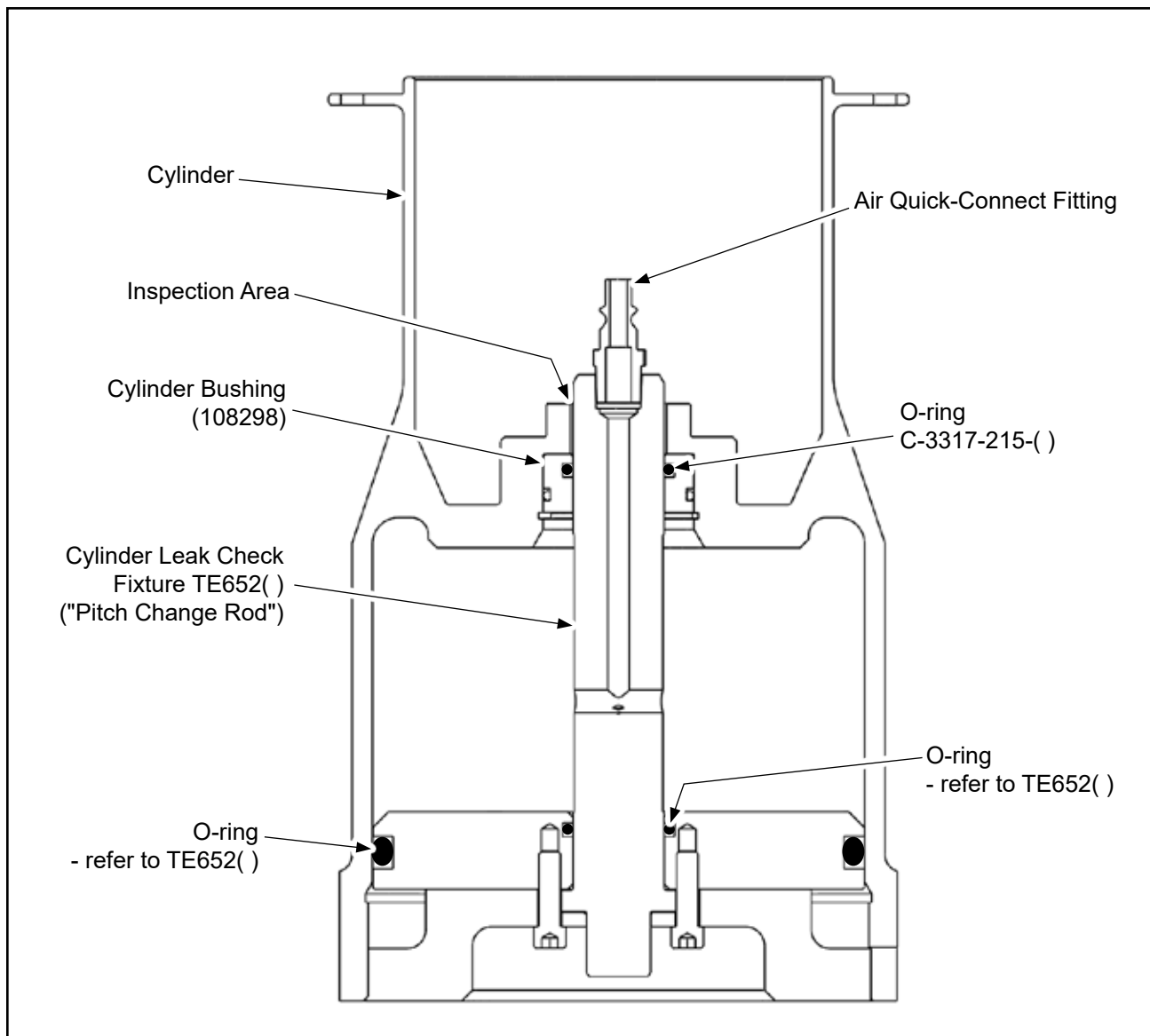

Cylinder Leak Check Procedure
Figure 6

HARTZELL PROPELLER INC.
SERVICE BULLETIN
HC-SB-61-392

108298 Cylinder Bushing and 108346 Hub Bushing

- (2) Apply a thin layer of grease CM12 to the O-rings, cylinder threads, and the diameter of the "pitch change rod" on the cylinder leak check fixture TE652().

CAUTION: DO NOT DAMAGE THE THREADS WHEN INSTALLING THE CYLINDER ONTO THE CYLINDER LEAK CHECK FIXTURE TE652().

- (3) Install the cylinder leak check fixture TE652() from the threaded end of the cylinder as shown in Figure 6.
- (a) Turn the fixture TE652() until the fixture threads are fully engaged with the cylinder.
- (4) Put the cylinder/fixture on a flat surface with the air quick-connect fitting facing up.
- (5) Apply 200 psi (13.79 bars) of air pressure to the air quick-connect fitting.
- (6) Check for leaks in the inspection area identified in Figure 6.
- (a) Apply leak detector CM122 to the inside of the cylinder where the "pitch change rod" of the cylinder leak check fixture TE652() contacts the cylinder.
- 1 Observe for approximately 10 seconds.
 - 2 A leak is indicated by continuous bubbling at the inspection area.
 - 3 A leak is not permitted.
- (b) If a leak is detected:
- 1 Inspect the O-rings for damage and unwanted material.
 - a Remove unwanted material.
 - b Replace the O-ring(s).
 - 2 Repeat the leak inspection procedure.
 - a If the leak cannot be stopped, replace the 108298 cylinder bushing, then repeat the leak inspection procedure.
- (7) After the test is complete, remove the cylinder from the cylinder leak check fixture TE652().
- (a) Remove and discard the O-ring (C-3317-215-2) from the ID of the 108298 cylinder bushing.
- (b) All fixtures and tools should be cleaned and stored to prevent contamination by airborne particles (dust, paint, etc.).

HARTZELL PROPELLER INC.
SERVICE BULLETIN
HC-SB-61-392

108298 Cylinder Bushing and 108346 Hub Bushing

E. 108346 Hub Bushing Inspection Criteria

- (1) Inspect the 108346 hub bushing in accordance with Table 3 and Figure 7 in this Service Bulletin.

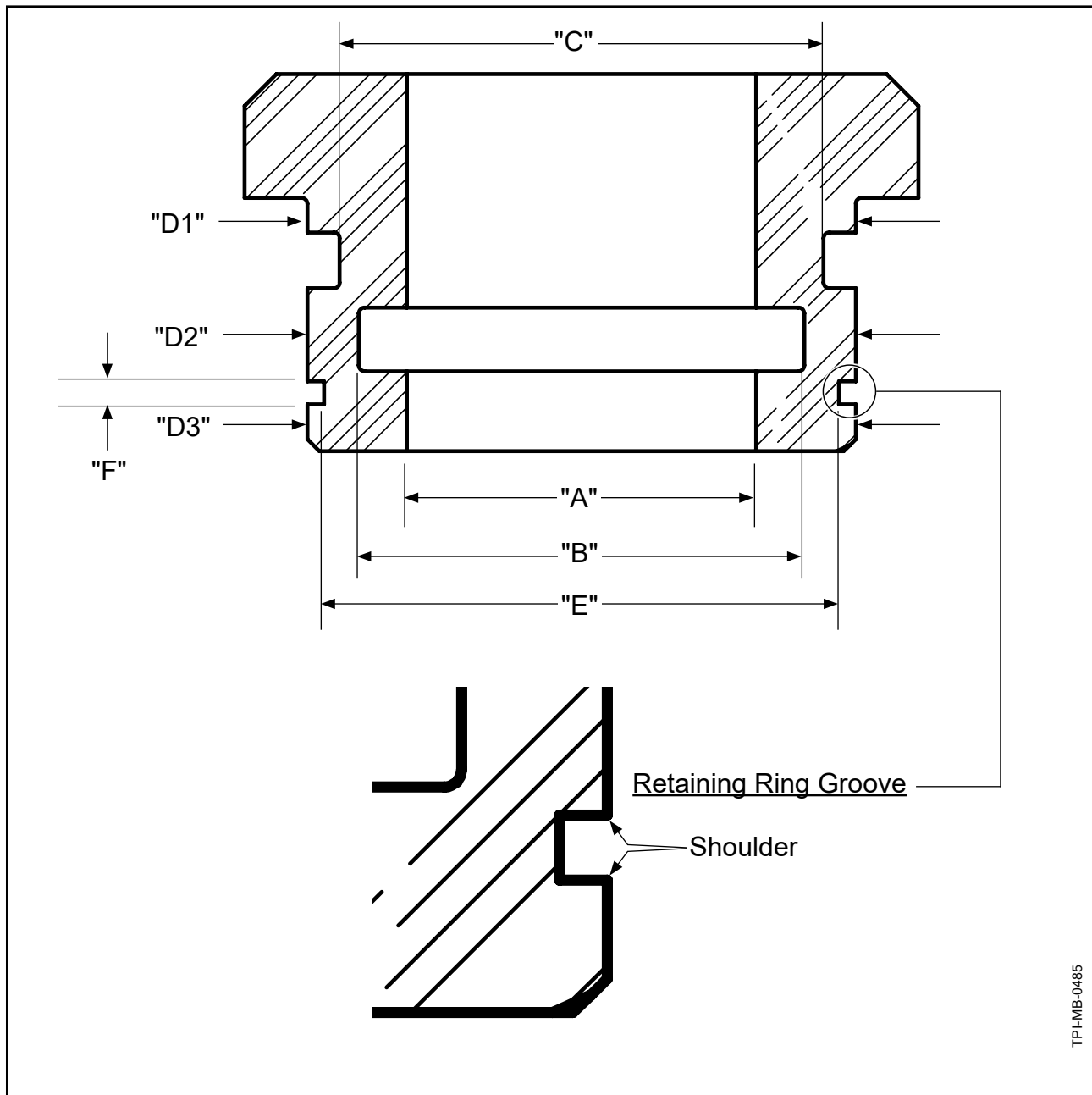

Inspection: 108346 Hub Bushing
Figure 7

HARTZELL PROPELLER INC.
SERVICE BULLETIN
HC-SB-61-392

108298 Cylinder Bushing and 108346 Hub Bushing

Inspect	Serviceable Limits	Corrective Action
<u>108346 Hub Bushing</u> (Refer to Figure 7)		
(1) Measure the ID of the hub bushing ("A").	The maximum permitted ID is 0.878 inch (22.30 mm). A smooth surface finish is required.	If the ID is greater than the permitted serviceable limits or the surface finish is not smooth, replace the hub bushing.
(2) Measure the ID of the hub bushing O-ring groove ("B").	The maximum permitted ID is 1.121 inches (28.47 mm). A smooth surface finish is required.	If the ID is greater than the permitted serviceable limits or the surface finish is not smooth, replace the hub bushing.
(3) Measure the OD of the hub bushing O-ring groove ("C").	The minimum permitted OD is 1.211 inches (30.76 mm).	If the OD is less than the permitted serviceable limits, replace the hub bushing.
(4) Measure the OD of the hub bushing at two locations ("D1") and ("D2").	The minimum permitted OD at each location is 1.373 inches (34.88 mm).	If the OD is less than the permitted serviceable limits, replace the hub bushing.
(5) Measure the OD of the hub bushing at location ("D3").	The minimum permitted OD is 1.368 inches (34.75 mm).	If the OD is less than the permitted serviceable limits, replace the hub bushing.
(6) Measure the OD of the retaining ring groove ("E").	The minimum permitted OD is 1.284 inches (32.62 mm).	If the OD is less than the permitted serviceable limits, replace the hub bushing.
(7) Visually examine each shoulder of the retaining ring groove for damage.	The maximum permitted total accumulated damage for each shoulder is 25% of the circumference.	If the damage for either shoulder is greater than the permitted serviceable limits, replace the hub bushing.
(8) Measure the width of the retaining ring groove ("F").	The maximum permitted width is 0.062 inch (1.57 mm).	If the width is greater than the permitted serviceable limits, replace the hub bushing.

Inspection Criteria: 108346 Hub Bushing
Table 3

HARTZELL PROPELLER INC.
SERVICE BULLETIN
HC-SB-61-392

108298 Cylinder Bushing and 108346 Hub Bushing

F. 108346 Hub Bushing Installation

NOTE: D-7432 hub assemblies that have an A-3789() hub bushing bonded into the hub must be modified in accordance with the "Hub Modification" section in this Service Bulletin before installing the 108346 hub bushing.

- (1) Remove/disassemble the propeller in accordance with the Disassembly chapter in the applicable Hartzell Propeller Inc. overhaul manual, **except:**
 - (a) Remove and discard the 104903 hub bushing.
- (2) Install the hub bushing (108346) and O-ring (C-3317-123) in accordance with Figure 8 and the following steps:
 - (a) Using a clean cloth dampened with MEK CM106, clean the OD of the 108346 hub bushing and the bore in the engine-side half of the hub.
 - (b) Install the O-ring (C-3317-123) in the groove on the OD of the hub bushing (108346).
 - (c) Install the hub bushing (108346) in the bore of the engine-side hub half.

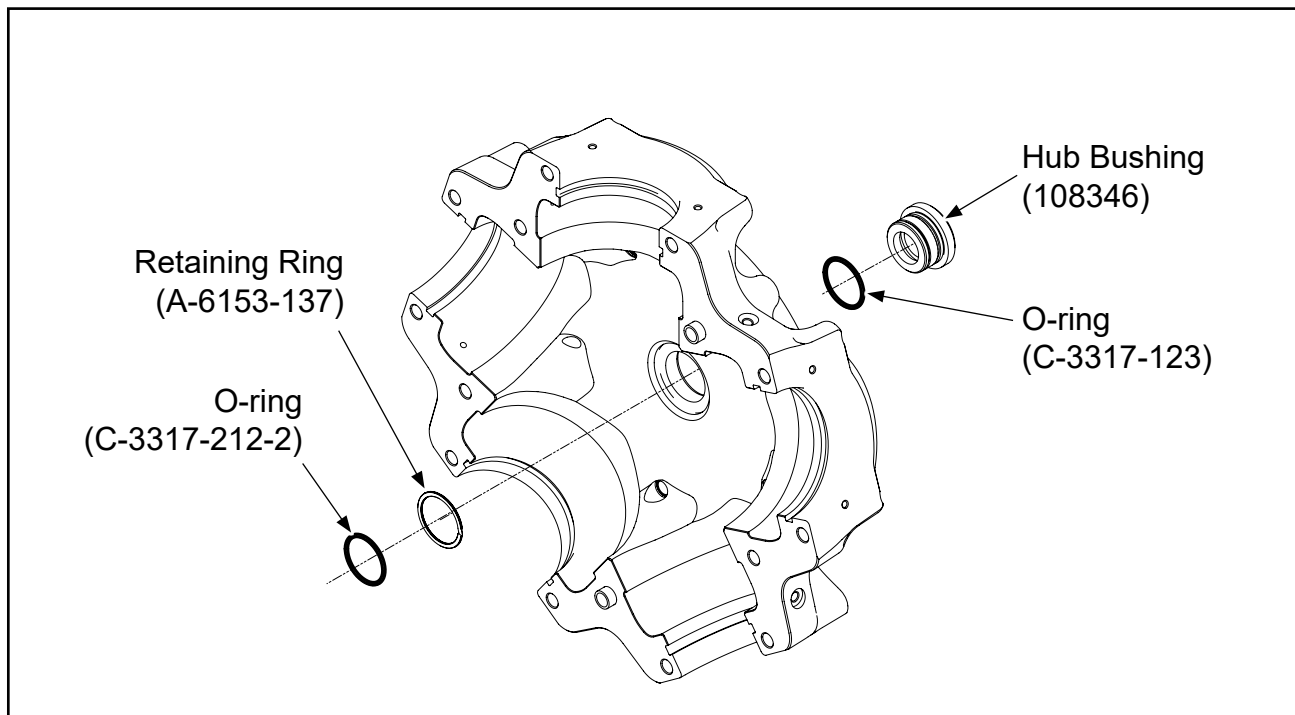

108346 Hub Bushing Installation
Figure 8

HARTZELL PROPELLER INC.
SERVICE BULLETIN
HC-SB-61-392

108298 Cylinder Bushing and 108346 Hub Bushing

- (d) Install the retaining ring (A-6153-137) in the groove on the hub bushing (108346).
 - (e) Install the O-ring (C-3317-212-2) in the groove on the ID of the hub bushing (108346).
- (3) Perform a leak inspection of the hub in accordance with the Aluminum Hub Overhaul chapter of Hartzell Propeller Inc. Standard Practices Manual 202A (61-01-02).

G. Propeller Assembly

- (1) After installing the 108298 cylinder bushing and the 108346 hub bushing, complete the assembly of the propeller in accordance with the Assembly chapter in the applicable Hartzell Propeller Inc. overhaul manual.
- (2) Make an entry in the propeller logbook indicating that the cylinder bushing and hub bushing replacement was performed in accordance with the procedures in this Service Bulletin.

HARTZELL PROPELLER INC.
SERVICE BULLETIN

HC-SB-61-392

108298 Cylinder Bushing and 108346 Hub Bushing

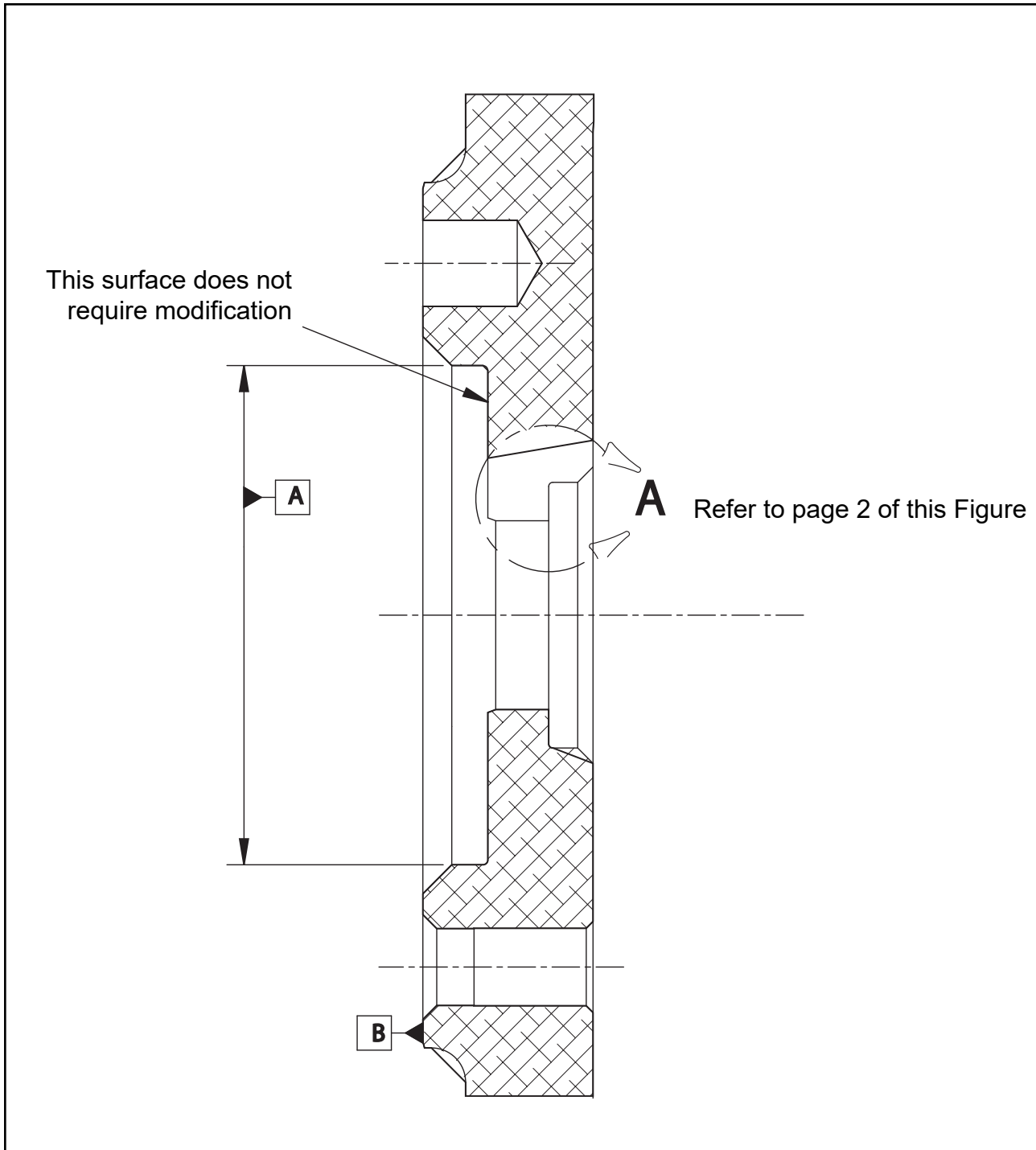

Hub Modification
Figure 9, page 1 of 2

HARTZELL PROPELLER INC.
SERVICE BULLETIN
HC-SB-61-392

108298 Cylinder Bushing and 108346 Hub Bushing

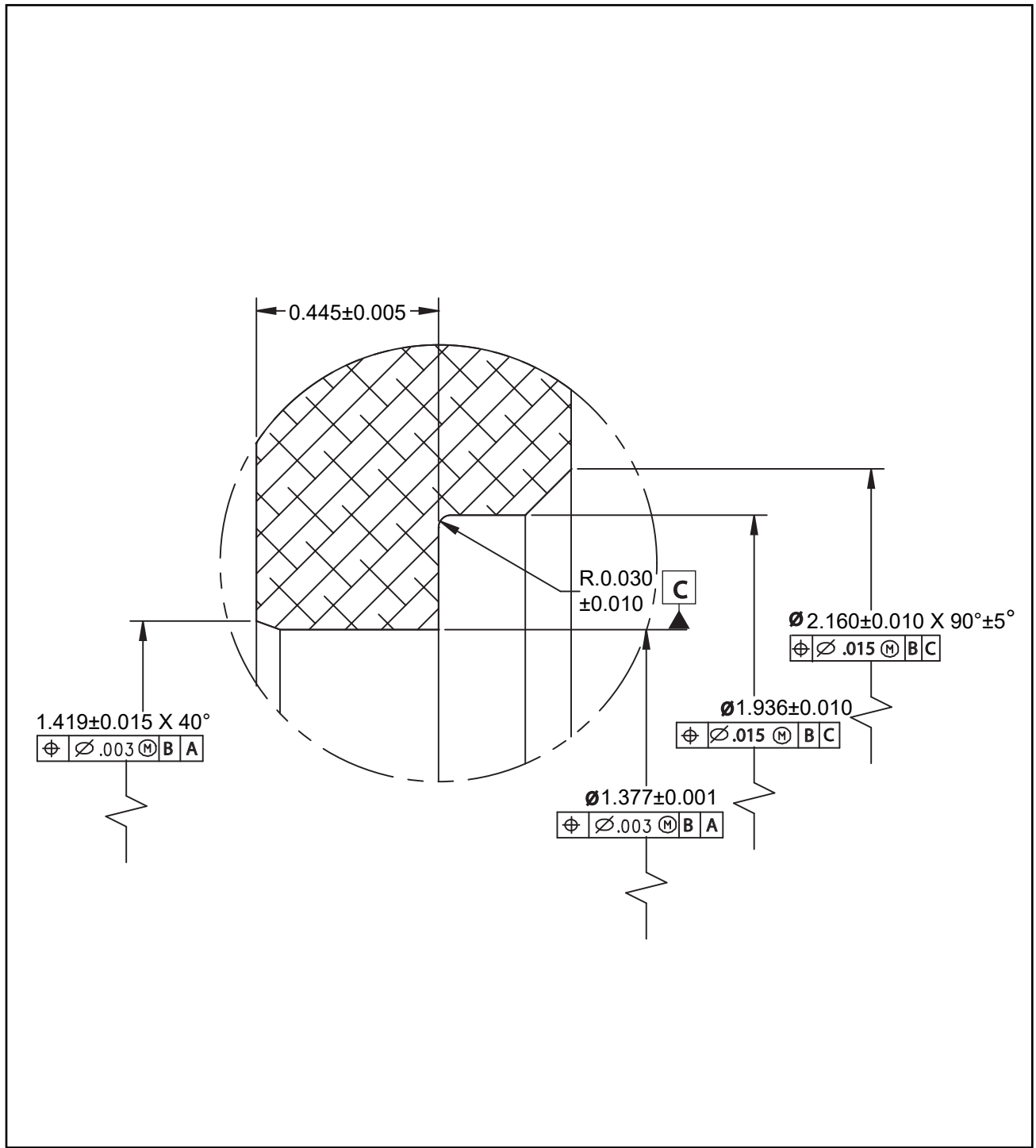

Hub Modification
Figure 9, page 2 of 2

HARTZELL PROPELLER INC.
SERVICE BULLETIN
HC-SB-61-392

108298 Cylinder Bushing and 108346 Hub Bushing

H. Hub Modification (if applicable)

NOTE: This procedure is required for D-7432 hub assemblies that have an A-3789() hub bushing bonded into the hub.

- (1) Remove the bonded A-3789() hub bushing in accordance with the applicable instructions in the Aluminum Hub Overhaul chapter of Hartzell Propeller Inc. Standard Practices Manual 202A (61-01-02).
- (2) Machine the propeller hub in accordance with Figure 9.
 - (a) Remove any burrs.
 - (b) Machined surfaces must have a surface finish of at least 63 micro inches (1.6 micro meters).
 - (c) Apply chemical conversion coating to the machined area in accordance with the Chromic Acid Anodizing chapter of Hartzell Propeller Inc. Standard Practices Manual 202A (61-01-02).

NOTE: After hub modification, the B-7418-1 bumper replaces the B-7418 bumper that was used with D-7432 hub assemblies.

I. Recommended Service Facilities

- (1) Hartzell Propeller Inc. has a worldwide network of Recommended Service Facilities for overhaul and repair of our products.
- (2) Each service facility must meet standard FAA requirements and additional Hartzell Propeller requirements before being recommended by Hartzell Propeller Inc. Each service facility is audited by Hartzell Propeller Inc. to verify the continuation of the standards.
- (3) Hartzell Propeller Inc. recommends that you use one of these service facilities when having your propeller overhauled or repaired.
- (4) For a current list of Hartzell Propeller Inc. Recommended Service Facilities, contact Hartzell Propeller Inc. Product Support or refer to the Hartzell Propeller Inc. website at www.hartzellprop.com.

J. Contact Information

Hartzell Propeller Inc.
Attn.: Hartzell Propeller Inc. Product Support
One Propeller Place
Piqua, Ohio 45356-2634 USA
Phone: (001) 937.778.4379
Fax: (001) 937.778.4215
E-mail: techsupport@hartzellprop.com