

**HARTZELL PROPELLER INC.**  
**ALERT SERVICE BULLETIN**  
**HC-ASB-61-404**  
**Propeller - A-321 Screw Inspection**

1. Planning Information

A. Effectivity

- (1) All Hartzell Propeller Inc. steel hub propeller models listed in Table 1 that were shipped new from Hartzell between April 18, 2023 and May 10, 2023 are affected by this Alert Service Bulletin - **except** propellers with serial numbers listed in Table 2.
- (2) All Hartzell Propeller Inc. steel hub propeller models listed in Table 1 that were overhauled between April 18, 2023 and May 10, 2023 are affected by this Alert Service Bulletin - **except** propellers with serial numbers listed in Table 2.
- (3) All A-321 screws, that were shipped from Hartzell Propeller Inc. between April 18, 2023 and May 10, 2023 are affected by this Alert Service Bulletin.
- (4) Hartzell Propeller Inc. steel hub propeller overhaul kits listed below, that were shipped from Hartzell Propeller Inc. between April 18, 2023 and May 10, 2023 are affected by this Alert Service Bulletin.

HC-B3TF-7A-OH	HC-B3TN-3D-OH	HC-B3TN-3M-OH	HC-B4TN-5(J,M)L
HC-B3TN-2-OH	HC-B3TN-3DY-OH1	HC-B4MP-3A-OH	HC-B5MA-3D-OH
HC-B3TN-3AF-OH	HC-B3TN-3DY-OH2	HC-B4MP-3C-OH	HC-B5MP-3F-OH
HC-B3TN-3B-OH	HC-B3TN-3G-OH		

**WARNING:** DO NOT USE OBSOLETE OR OUTDATED INFORMATION. PERFORM ALL INSPECTIONS OR WORK IN ACCORDANCE WITH THE MOST RECENT REVISION OF THIS ALERT SERVICE BULLETIN. INFORMATION CONTAINED IN THIS ALERT SERVICE BULLETIN MAY BE SIGNIFICANTLY CHANGED FROM EARLIER REVISIONS. FAILURE TO COMPLY WITH THIS ALERT SERVICE BULLETIN OR THE USE OF OBSOLETE INFORMATION MAY CREATE AN UNSAFE CONDITION THAT MAY RESULT IN DEATH, SERIOUS BODILY INJURY, AND/OR SUBSTANTIAL PROPERTY DAMAGE. REFER TO THE SERVICE BULLETIN INDEX FOR THE MOST RECENT REVISION LEVEL OF THIS ALERT SERVICE BULLETIN.

B. Concurrent Requirements

- (1) Additional service documents may apply to the components/propellers affected by this Alert Service Bulletin. Compliance with additional service documents may be necessary in conjunction with the completion of the Accomplishment Instructions in this Alert Service Bulletin. Refer to the Hartzell Propeller Inc. website at [www.hartzellprop.com](http://www.hartzellprop.com) for a cross-reference of service documents.

HARTZELL PROPELLER INC.

# ALERT SERVICE BULLETIN

HC-ASB-61-404

## Propeller - A-321 Screw Inspection

### C. Reason

- (1) An internal inspection of the A-321 screw by Hartzell Propeller Inc. found that some A-321 screws were out of specification.

### D. Description

- (1) This Alert Service Bulletin provides Instructions for Continued Airworthiness (ICA).
- (2) This Alert Service Bulletin provides instructions for an on-wing inspection of the A-321 screw for the affected propellers.
- (3) This Alert Service Bulletin provides instructions for inspecting A-321 screws in inventory/stock, including overhaul kits.
- (4) This Alert Service Bulletin provides instructions for replacing A-321 screws on affected propellers.
  - (a) Hartzell Propeller Inc. will provide the parts listed in the Material Information section and warrant the labor costs on affected propellers associated with replacement of the A-321 screw.
    - 1 Refer to the Appendix section of this Alert Service Bulletin for additional information about the warranty program.

### E. Compliance

- (1) Within 100 flight hours from the release date of this Alert Service Bulletin, perform the on-wing inspection and replace the affected A-321 screws in accordance with the Accomplishment section of this Alert Service Bulletin.
- (2) Before use or within 10 days from the release date of this Alert Service Bulletin, whichever occurs first, perform the inventory/stock inspection for all A-321 screws in accordance with the Accomplishment section of this Alert Service Bulletin.
  - (a) Immediately quarantine all affected screws for subsequent replacement.

### F. Approval

- (1) FAA acceptance has been obtained on technical data in this publication.

### G. Manpower

- (1) Approximately 3.0 man-hours is required to perform the on-wing inspection.
- (2) Additionally, a maximum of 1.0 man-hour per blade clamp is required to perform replacement of the A-321 screw.

# ALERT SERVICE BULLETIN

HC-ASB-61-404

## Propeller - A-321 Screw Inspection

H. Weight and Balance

(1) Not changed

I. Electrical Load Data

(1) Not changed

J. References

(1) Applicable Hartzell Propeller Inc. Propeller Owner's manuals - Available on the Hartzell Propeller Inc. website at [www.hartzellprop.com](http://www.hartzellprop.com)

(2) Applicable Hartzell Propeller Inc. Propeller Overhaul manuals

K. Other Publications Affected

(1) None

2. Material Information

A. Material Supplied by Hartzell Propeller (if replacement is necessary)

<u>Part Number</u>	<u>Description</u>	<u>Qty</u>
A-321	Screw, 3/8-24, Double 60° Head	As Required
A-3838-3-2	Cotter Pin	As Required

B. Special Tooling

None

HARTZELL PROPELLER INC.  
**ALERT SERVICE BULLETIN**  
HC-ASB-61-404  
Propeller - A-321 Screw Inspection

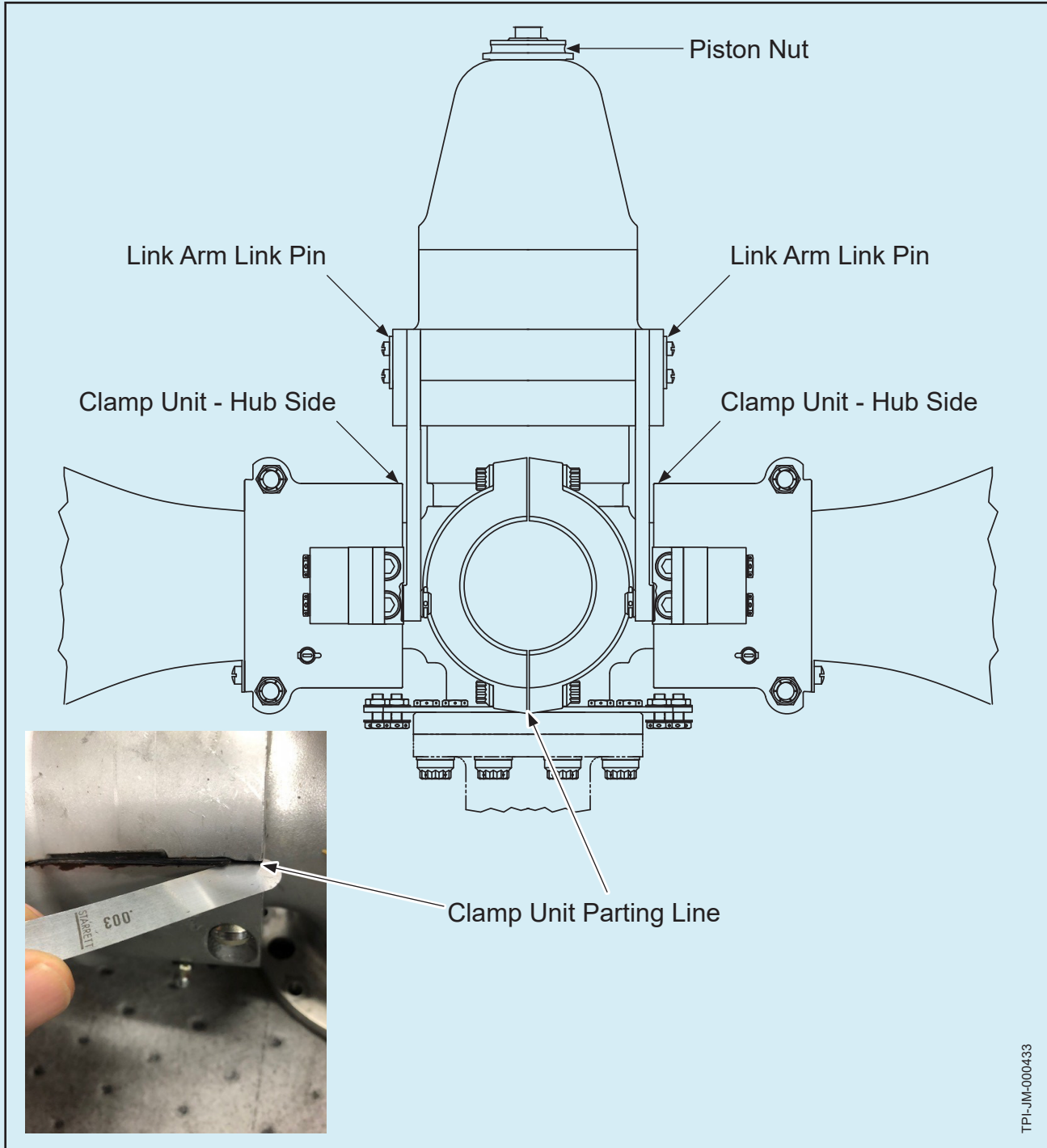

**Example of a Steel Hub Propeller**  
**Figure 1**

# ALERT SERVICE BULLETIN

HC-ASB-61-404

## Propeller - A-321 Screw Inspection

### 3. Accomplishment Instructions

#### A. On-Wing Inspection of A-321 Screw

- (1) Remove the spinner dome in accordance with the applicable Hartzell Propeller Inc. Owner's Manual.
- (2) Depending on propeller application, remove the piston nut from the pitch change rod and/or link arm link pin from the piston unit using appropriate tooling. Refer to Figure 1.  
NOTE 1: Make sure the pitch change rod does not move during removal of the piston nut.
  - (a) Cut and remove the safety wire, if applicable.
- (3) With the propeller in feathering position, insert a 0.003 (0.08 mm) feeler gauge into the clamp unit parting line on the hub side. Refer to Figure 1.
  - (a) If the feeler gauge inserts between the clamp unit parting line, the A-321 screw is affected by this Alert Service Bulletin and must be replaced.
    - 1 Mark the affected A-321 screw using a non-graphite pencil CM162 or paint marker.
- (4) Rotate the propeller into low pitch blade angle.
- (5) With the propeller in low pitch position, insert a 0.003 (0.08 mm) feeler gauge into the clamp unit parting line on the hub side. Refer to Figure 1.
  - (a) If the feeler gauge inserts between the clamp unit parting line, the A-321 screw is affected by this Alert Service Bulletin and must be replaced.
    - 1 Mark the affected A-321 screw using a non-graphite pencil CM162 or paint marker.
- (6) Inspect all remaining A-321 screws in each blade clamp unit in accordance with steps (3) through (5)(a)1.

HARTZELL PROPELLER INC.

# ALERT SERVICE BULLETIN

## HC-ASB-61-404

### Propeller - A-321 Screw Inspection

- (7) If no affected A-321 screws are found,
  - (a) Using appropriate tooling, install the piston nut onto the pitch change rod and/or install the link arm link pin onto the piston unit.
    - (1) If installing the piston nut, torque to 120 Ft-Lb (162 N·m).
    - (2) If installing the link arm link pin, install safety wire (if applicable).
  - (b) Install the spinner dome in accordance with the applicable Hartzell Propeller Inc. Owner's Manual.
  - (c) Make an entry in the propeller logbook indicating compliance with this Alert Service Bulletin.
- (8) If affected A-321 screws are found, the affected A-321 screws must be replaced by a certified propeller repair station with the appropriate rating in accordance with the Accomplishment section of this Alert Service Bulletin.

#### B. Replacing A-321 Screws on an Affected Propeller

**NOTE:** Replacement of A-321 screws must be performed by a certified propeller repair station with the appropriate rating.

- (1) Remove all affected A-321 screws in accordance with the applicable Hartzell Propeller Inc. Overhaul Manual.
  - (a) Return the affected A-321 screws to Hartzell Propeller Inc. in accordance with the Appendix section in this Alert Service Bulletin.
- (2) Install new A-321 screws in accordance with the applicable Hartzell Propeller Inc. Overhaul Manual.
- (3) Install the piston nut and/or the link arm in accordance with the applicable Hartzell Propeller Inc. Overhaul Manual.
- (4) Install the spinner dome in accordance with the applicable Hartzell Propeller Inc. Owner's manual.
- (5) Make an entry in the propeller logbook indicating the affected A-321 screws were replaced in accordance with this Alert Service Bulletin.

**HARTZELL PROPELLER INC.**  
**ALERT SERVICE BULLETIN**  
**HC-ASB-61-404**  
**Propeller - A-321 Screw Inspection**

C. Inventory/Stock Inspection of A-321 Screw

**NOTE:** All overhaul kits that are listed in the Effectivity section and A-321 screws that were shipped from Hartzell Propeller Inc. between April 18, 2023 and May 10, 2023 must be inspected. Affected screws must be returned to Hartzell Propeller Inc.

- (1) Measure the A-321 screw to the dimensions referenced in Figure 2.
  - (a) Using a non-graphite pencil CM162 or paint marker, mark all affected A-321 screws.

**NOTE:** An affected screw is one that does not meet the dimensions specified in Figure 2.

- (2) If affected A-321 screws are identified in inventory/stock, refer to the Appendix section in this Alert Service Bulletin for instructions to return the affected A-321 screws and receive replacements.

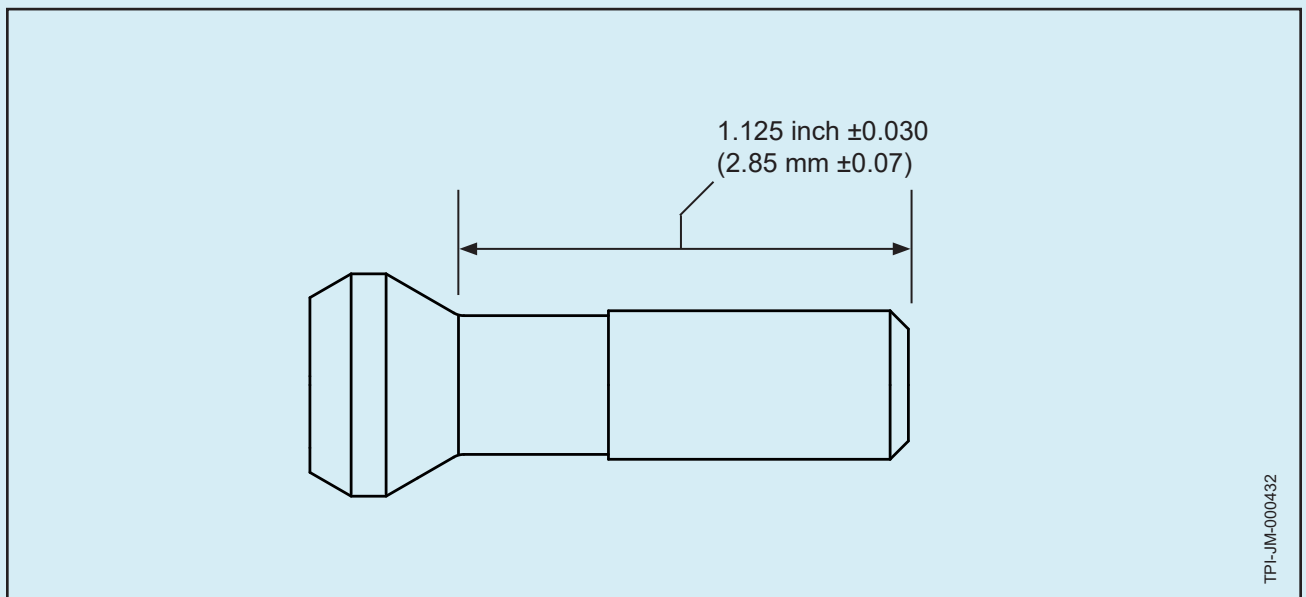

**A-321 Screw Dimensions**  
**Figure 2**

HARTZELL PROPELLER INC.

# ALERT SERVICE BULLETIN

## HC-ASB-61-404

### Propeller - A-321 Screw Inspection

<b>Affected Propeller Models</b>		
BHC-92WF-3G	HC-A3MV20-2	HC-B3TN-3AFY
BHC-92WF-3LG	HC-A3MV20-2L	HC-B3TN-3B
BHC-92ZF-1D1	HC-A3MV20-3L	HC-B3TN-3BY
HA-A2MV20-1B	EHC-A3MVF-2B	HC-B3TN-3C
HC-92WK-1D	HC-A3MVF-2D	HC-B3TN-3D
HC-92WK-2B	HC-A3MVF-3L	HC-B3TN-3DL
HC-92WK-8L	HC-A3MVF-5AL	HC-B3TN-3DY
HC-92ZK-2B	HC-A3MVF-7B	HC-B3TN-3G
HC-92ZK-8D	PHC-A3MVF-4	HC-B3TN-3H
HC-92ZK-8L	HC-A3MVK-2A	HC-B3TN-3K
HC-92ZK-1D	HC-A3MVK-2B	HC-B3TN-3M
HC-A2MV20-2	HC-A3MVK-4	HC-B3TN-3N
HC-A2MV20-2A	HC-B3R20-4	HC-B3TN-3NY
HC-A2MV20-4A1	HC-B3R30-2EA	HC-B3TN-3UL
HC-A2MV20-1A	HC-B3R30-4	HC-B3TN-3Z
HC-A2MV20-3L	HC-B3R30-4B	HC-B3TN-5C
HC-A2MV20-5L	HC-B3W30-2B	HC-B3TN-5E
HC-A2MVL-1	HC-B3Z20-1	HC-B3TN-5FL
HC-A2MVF-1A	HC-B3Z20-2A	HC-B3TN-5G
BHC-A2MVF-1A	HC-B3Z30-2EB	HC-B3TN-5K
HC-A2MVF-2	HC-B3MN-3	HC-B3TN-5M
BHC-A2MVF-3	HC-B3MN-5L	HC-B3TN-5NL
HC-A2MVK-1	HC-B3TF-7A	HC-B3TN-5P
HC-A2MVK-2	HC-B3TN-2	HC-B3TN-5U
HC-A2MVL-2	HC-B3TN-3AE	HC-B3TN-5V
HC-A3MV20-1D	HC-B3TN-3AEY	HC-B3TW-3
HC-A3MV20-1F	HC-B3TN-3AF	HC-B3TW-3Y

**Affected Propeller Models**  
**Table 1, page 1 of 2**



HARTZELL PROPELLER INC.

# ALERT SERVICE BULLETIN

## HC-ASB-61-404

### Propeller - A-321 Screw Inspection

<b>Affected Propeller Models</b>		
HC-B4MN-5AL	HC-B4TN-5KL	HC-B5MA-3DT
HC-B4MN-5B	HC-B4TN-5ML	HC-B5MA-3J
HC-B4MN-5BL	HC-B4TN-5NL	HC-B5MA-3M
HC-B4MP-3A	HC-B4TN-5PL	HC-B5MA-5A
HC-B4MP-3B	HC-B4TN-5QL	HC-B5MA-5H
HC-B4MP-3C	HC-B4TW-3	HC-B5MA-5HT
HC-B4TN-1	HC-B5MA-2	HC-B5MP-3F
HC-B4TN-3A	HC-B5MA-2A	HC-B5MP-5BL
HC-B4TN-3B	HC-B5MA-3	HC-B5MP-5CL
HC-B4TN-3C	HC-B5MA-3A	HC-D2MV20-3
HC-B4TN-5F	HC-B5MA-3B	HC-D2MV20-7
HC-B4TN-5FL	HC-B5MA-3C	HC-D2MV20-8
HC-B4TN-5GL	HC-B5MA-3D	HC-D3MV20-6L
HC-B4TN-5JL	HC-B5MA-3DA	HC-D3MV20-8D

**Affected Propeller Models**  
**Table 1, page 2 of 2**

HARTZELL PROPELLER INC.

# ALERT SERVICE BULLETIN

## HC-ASB-61-404

### Propeller - A-321 Screw Inspection

ATTENTION: PROPELLERS LISTED IN TABLE 2 HAVE PREVIOUSLY COMPLIED WITH THE REQUIREMENTS OF THIS ALERT SERVICE BULLETIN. NO FURTHER ACTION IS REQUIRED.

Propeller Model	Serial Numbers
B3N10454S/HC-B3TN-3D/T10282NS+4/3434-17P	BUA35211
B3N10454S/HC-B3TN-3D/T10282NS+4/3434-17P	BUA35213
B4N10375S/HC-B4TN-3C/T10702NS/D-3434-18P	CDA6121
B4N10375S/HC-B4TN-3C/T10702NS/D-3434-18P	CDA6122
B4N10375S/HC-B4TN-3C/T10702NS/D-3434-18P	CDA6124
B4N10375S/HC-B4TN-3C/T10702NS/D-3434-18P	CDA6126
B4N10375S/HC-B4TN-3C/T10702NS/D-3434-18P	CDA6127
B5P10311S/HC-B5MP-3F/M11276NS/E-7256-P	EVA3906
B5P10311S/HC-B5MP-3F/M11276NS/E-7256-P	EVA3908
B5A10247S/HC-B5MA-3D/M11691NS/D-5497-P	HBA2645
B5A10247S/HC-B5MA-3D/M11691NS/D-5497-P	HBA2651
B5A10247S/HC-B5MA-3D/M11691NS/D-5497-P	HBA2646
B5A10034S/HC-B5MA-3DT/M11691NS/D-5497	HBA2653
B5P10311S/HC-B5MP-3F/M11276NS/E-7256-P	EVA3907
B5P10311S/HC-B5MP-3F/M11276NS/E-7256-P	EVA3914
B5P10311S/HC-B5MP-3F/M11276NS/E-7256-P	EVA3915
B5P10311S/HC-B5MP-3F/M11276NS/E-7256-P	EVA3913
B3300077/HC-B3R30-4B/R10152N-5.5	EMA1397
B3300077/HC-B3R30-4B/R10152N-5.5	EMA1398
B3N21600S/HC-B3TN-3AF/T10890CNK-2(*2)	BUA35200
B5A10242S/HC-B5MA-3M/M11691NSK/D-5497P	HBA2650
B5A10242S/HC-B5MA-3M/M11691NSK/D-5497P	HBA2654

**Previously Complied Propellers/Serial Numbers  
Table 2**

**HARTZELL PROPELLER INC.**  
**ALERT SERVICE BULLETIN APPENDIX**  
**HC-ASB-61-404**  
**Propeller - A-321 Screw Inspection**

1. Warranty Program Information

A. Eligibility

- (1) All Hartzell Propeller Inc. steel hub propeller models listed in Table 1 that were shipped new from Hartzell between April 18, 2023 and May 10, 2023 are eligible for this warranty program - **except** propellers with serial numbers listed in Table 2.
- (2) All Hartzell Propeller Inc. steel hub propeller models listed in Table 1 that were overhauled between April 18, 2023 and May 10, 2023 are eligible for this warranty program - **except** propellers with serial numbers listed in Table 2.
- (3) Affected A-321 screws in inventory/stock are eligible for this warranty program.

B. Parts

- (1) Hartzell Propeller Inc. will replace affected A-321 screws with new A-321 screws free of charge.
  - (a) All affected A-321 screws must be returned to Hartzell Propeller Inc.
    - 1 Contact Hartzell Propeller Inc. Product Support department before returning the affected A-321 screws.
- (2) Complete and sign the Parts Order/Compliance Form in this Appendix section, then send the completed form to Hartzell Propeller Inc. for processing.

C. Labor

- (1) Hartzell Propeller Inc. will authorize payment for the allowable labor charges when the on-wing inspection and/or replacement of the A-321 screw is performed in accordance with the Accomplishment Instructions of this Alert Service Bulletin.
  - (a) Refer to the Manpower section of this Alert Service Bulletin for warranted procedures and allowable man-hours.
  - (b) Labor charges will be reimbursed at the service facility's CURRENT POSTED SHOP LABOR RATE, pending Hartzell Propeller Inc. approval.
- (2) Send the invoice for labor charges to Hartzell Propeller Inc. for processing.
  - (a) Reference the same warranty claim number issued by Hartzell for the replacement parts.

HARTZELL PROPELLER INC.

# ALERT SERVICE BULLETIN APPENDIX

HC-ASB-61-404

## Propeller - A-321 Screw Inspection

### D. Contact Information

- (1) Fax, Email, or mail the Parts Order/Compliance Form to:

Hartzell Propeller Inc.  
Attn: Alert Service Bulletin 404 Coordinator  
One Propeller Place  
Piqua, OH 45356 USA  
Phone: 937.778.4379  
Fax: 937.778.4215 (Intl. 001.937.778.4215)  
Email: techsupport@hartzellprop.com

**HARTZELL PROPELLER INC.**  
**ALERT SERVICE BULLETIN APPENDIX**  
**HC-ASB-61-404**  
**Propeller - A-321 Screw Inspection**

**Parts Order/Compliance Form**

<b>Warranty Claim Number:</b>		
<b>Propeller Information:</b>		
Propeller Model:	Propeller S/N:	
TSN (Time Since New):	TSO (Time Since Overhaul):	
<b>Aircraft Information</b>		
Aircraft Model:	Aircraft Registration #:	
<b>Owner Information:</b>		
Name:		
City:	State:	
Zip/Postal Code:	Country:	
E-mail:	Phone:	
<b>Repair Facility/Shipping Information:</b>		
Company:	Contact Name:	
Address:		
City:	State:	
Zip/Postal Code:	Country:	
E-mail:	Phone:	Fax:
<b>Replacement Parts:</b>		
Refer to the Material Information section of this Alert Service Bulletin for a list of parts that will be provided.		
<b>Signature:</b>		
Repair Technician's Signature:	Date:	
Send this completed <b>and signed</b> form to Hartzell Propeller Inc. Product Support Department: Fax - (001) 937.778.4215 or E-mail - techsupport@hartzellprop.com		

**DO NOT WRITE BELOW THIS LINE - FOR HARTZELL PROPELLER INC. USE ONLY**

Authorized By:
----------------

Document No. HC-ASB-61-404    Date of Issue: Jul 07/23    Revision: N/A    Rev. Date: N/A

HARTZELL PROPELLER INC.

# ALERT SERVICE BULLETIN APPENDIX

HC-ASB-61-404

Propeller - A-321 Screw Inspection

(Blank Page)