



To: HOLDERS OF COMPONENT MAINTENANCE MANUAL 24-32-21, 539CH2

Subject: CMM Revision No. 4 Dated Jan 23/2023

Replace revised pages by adding and removing pages for pages dated Jan 23/2023.

NOTE: The CMM can be downloaded from the internet at www.saftbatteries.com

HIGHLIGHTS

CHAPTER/SECTION PAGE NUMBER	DESCRIPTION OF CHANGE
Title Page T-1	Add Revision 4 with Date and removed confusing wording
Record of Revisions ROR 1	Add revision 4
Record of Temporary Revisions RTR 1	Update table headings
Service Bulletin List SBL 1	Removed page information
List of Effective Pages LEP 1	Corrected/Changed pages
List of Illustrations LOI 1	Updated Illustration page info
Introduction Intro 1	Clarification
Introduction Intro 2, 4	Update CAGE code, added abbreviation
Testing and Fault Isolation 1001, 1002	Updated IPL and table link
Testing and Fault Isolation 1003, 1004	Moved information from Repair section to replace O-ring on vent valve
Testing and Fault Isolation 1005	Repaginate
Testing and Fault Isolation 1006, 1008 - 1010, 1012	Added information on vent valve tool and clarification
Testing and Fault Isolation 1007, 1011	Clarifications and improvements
Testing and Fault Isolation 1013	Relocated Lower nut tightness to TESTING section
Testing and Fault Isolation 1014, 1016	Corrected links and descriptions to use DISASSEMBLY and ASSEMBLY for component replacement.
Disassembly 3001	Updated IPL figure link and provided clarification

24-32-21

Highlights Page 1 of 2
Jan 23/2023



CHAPTER/SECTION PAGE NUMBER	DESCRIPTION OF CHANGE
Cleaning 4001, 4002	Updated IPL figure link, added sensor harness step.
Check 5001	Updated IPL figure link and clarifications
Check 5002	Added thermostat plate information
Repair 6001 - 6002	Updated IPL figure link, removed duplicate information where DISASSEMBLY and ASSEMBLY sections are to be used.
Assembly 7001, 7003	Updated IPL figure link, add lubrication information
Fits and Clearances 8001	Corrected Item number
Special Tools, Fixtures, Equipment, and Consumables 9001	Updated CAGE code and added torque device
Illustrated Parts List 10002 - 10003, 10004 – 10007, 10008	Updated CAGE info and figure to IPL Figure
Storage (Including Transportation) 15003 - 15005	Updated information and removed obsolete information



ECCN: EAR99
CAGE Code 09052
711 GIL HARBIN INDUSTRIAL BOULEVARD
VALDOSTA, GEORGIA 31601
Phone: +1 (229) 247-2331 Fax: +1 (229) 247-8486

COMPONENT MAINTENANCE MANUAL

WITH ILLUSTRATED PARTS LIST

Nickel Cadmium Aircraft Battery

539CH2

Website: www.saftbatteries.com

24-32-21

T-1
Rev 4 Jan 23/2023



COMPONENT MAINTENANCE MANUAL
539CH2

This document and all information contained herein are the property of Saft. Its use is restricted solely to the maintenance of Saft batteries and may under no circumstances be used for any other manufacturer's products. No person may, in whole or in part, duplicate, use or disclose this information for any other purpose without the prior written consent of Saft.

24-32-21

T-2
May 19/2021



COMPONENT MAINTENANCE MANUAL
539CH2

RECORD OF REVISIONS

REV NO.	ISSUE DATE	INSERT DATE	BY	REV NO.	ISSUE DATE	INSERT DATE	BY
0	Aug 02/2010	Aug 02/2010	Saft				
1	Jan 29/2018	Jan 29/2018	Saft				
2	May 19/2021	May 19/2021	Saft				
3	May 4/2022	May 4/2022	Saft				
4	Jan 23/2023	Jan 23/2023	Saft				



COMPONENT MAINTENANCE MANUAL
539CH2

PAGE INTENTIONALLY LEFT BLANK

24-32-21

ROR 2
Jan 23/2023



COMPONENT MAINTENANCE MANUAL
539CH2

RECORD OF TEMPORARY REVISIONS

TEMPORARY REV NO	ISSUE DATE	INSERTED DATE / INSERTED BY	DATE REMOVED / REMOVED BY	DATE INCORPORATED



COMPONENT MAINTENANCE MANUAL
539CH2

PAGE INTENTIONALLY LEFT BLANK

24-32-21

RTR 2
May 4/2022



COMPONENT MAINTENANCE MANUAL
539CH2

SERVICE BULLETIN LIST

SERVICE BULLETIN		DATE	TITLE
NUMBER / REV	DATE	INCORPORATION OR NO EFFECT	

|

24-32-21

SBL 1
Jan 23/2023



COMPONENT MAINTENANCE MANUAL
539CH2

PAGE INTENTIONALLY LEFT BLANK

24-32-21

SBL 2
May 4/2022



COMPONENT MAINTENANCE MANUAL
539CH2

LIST OF EFFECTIVE PAGES

SUBJECT	PAGE	DATE	SUBJECT	PAGE	DATE
TITLE PAGE	T-1 T-2	Jan 23/2023 May 19/2021	DISASSEMBLY	3001 3002	Jan 23/2023 May 4/2022
RECORD OF REVISIONS	ROR 1 ROR 2	Jan 23/2023 Blank	CLEANING	4001 4002	Jan 23/2023 Jan 23/2023
RECORD OF TEMPORARY REVISIONS	RTR 1 RTR 2	Jan 23/2023 Blank	CHECK	5001 5002	Jan 23/2023 Jan 23/2023
SERVICE BULLETIN LIST	SBL 1 SBL 2	Jan 23/2023 Blank	REPAIR	6001 6002	Jan 23/2023 Jan 23/2023
LIST OF EFFECTIVE PAGES	LEP 1 LEP 2	Jan 23/2023 Blank	ASSEMBLY	7001 7002 7003 7004	Jan 23/2023 May 4/2022 Jan 23/2023 Blank
TABLE OF CONTENTS	TOC 1 TOC 2	May 19/2021 Blank	FITS AND CLEARANCES	8001 8002	Jan 23/2023 Blank
LIST OF ILLUSTRATIONS	LOI 1 LOI 2	Jan 23/2023 Blank	SPECIAL TOOLS, FIXTURES, EQUIPMENT, AND CONSUMABLES	9001 9002	Jan 23/2023 May 4/2022
LIST OF TABLES	LOT 1 LOT 2	May 19/2021 Blank	ILLUSTRATED PARTS LIST	10001 10002 10003 10004 10005 10006 10007 10008 10009 10010	May 19/2021 Jan 23/2023 Jan 23/2023 Jan 23/2023 Jan 23/2023 Jan 23/2023 Jan 23/2023 Jan 23/2023 Jan 23/2023 Blank
INTRODUCTION	Intro 1 Intro 2 Intro 3 Intro 4	Jan 23/2023 Jan 23/2023 May 4/2022 Jan 23/2023	STORAGE (INCLUDING TRANSPORTATION)	15001 15002 15003 15004 15005 15006	May 4/2022 May 19/2021 Jan 23/2023 Jan 23/2023 Jan 23/2023 Blank
DESCRIPTION AND OPERATION	1 2 3 4	May 19/2021 May 4/2022 May 4/2022 May 4/2022			
TESTING AND FAULT ISOLATION	1001 1002 1003 1004 1005 1006 1007 1008 1009 1010 1011 1012 1013 1014 1015 1016	Jan 23/2023 Jan 23/2023 Jan 23/2023 Jan 23/2023 Jan 23/2023 Jan 23/2023 Jan 23/2023 Jan 23/2023 Jan 23/2023 Jan 23/2023 Jan 23/2023 Jan 23/2023 Jan 23/2023 Jan 23/2023 May 4/2022 Jan 23/2023			

24-32-21

LEP 1
Jan 23/2023



COMPONENT MAINTENANCE MANUAL
539CH2

PAGE INTENTIONALLY LEFT BLANK

24-32-21

LEP 2
May 4/2022



COMPONENT MAINTENANCE MANUAL
539CH2

TABLE OF CONTENTS

PARAGRAPH TITLE	PAGE
INTRODUCTION	Intro 1
DESCRIPTION AND OPERATION	1
TESTING AND FAULT ISOLATION	1001
AUTOMATIC TEST REQUIREMENTS (ATLAS)	N/A
DISASSEMBLY	3001
CLEANING	4001
CHECK	5001
REPAIR	6001
ASSEMBLY	7001
FITS AND CLEARANCES	8001
SPECIAL TOOLS, FIXTURES, EQUIPMENT, AND CONSUMABLES	9001
ILLUSTRATED PARTS LIST	10001
STORAGE (INCLUDING TRANSPORTATION)	15001



COMPONENT MAINTENANCE MANUAL
539CH2

PAGE INTENTIONALLY LEFT BLANK

24-32-21

TOC 2
May 4/2022



COMPONENT MAINTENANCE MANUAL
539CH2

LIST OF ILLUSTRATIONS

FIGURE	DESCRIPTION	PAGE
Intro 1	Universal Recycling Symbols	Intro 3
1	Nickel Cadmium Battery	1
1001	Process Flow for Battery Restoration	1002
1002	Connector Pinout	1005
1003	Position of T02 in Cell Vent Seal	1009
1004	Special Testing Flow Chart	1013
7001	Cell and Spacer Installation	7002
7002	Cell Number and Polarity Orientation	7003
IPL Figure 1	Battery, Exploded View (#1 of 4)	10004
IPL Figure 1	Battery, Exploded View (#2 of 4)	10005
IPL Figure 1	Battery, Exploded View (#3 of 4)	10006
IPL Figure 1	Battery, Exploded View (#4 of 4)	10007
15001	Standby Period	15002
15002	Inactive Standby Storage Schedule	15003



COMPONENT MAINTENANCE MANUAL
539CH2

PAGE INTENTIONALLY LEFT BLANK

24-32-21

LOI 2
May 4/2022



COMPONENT MAINTENANCE MANUAL
539CH2

LIST OF TABLES

TABLE	DESCRIPTION	PAGE
1	Leading Particulars	2
1001	Sensor Harness Check Values	1005
1002	Initial Discharge (Off-wing Capacity)	1006
1003	Charge Table	1007
1004	Final Charge Voltage Limit	1008
1005	Capacity Check (Second Discharge)	1010
1006	Battery Faults	1014
1007	Cell Faults	1015
1008	Physical Faults	1016
8001	Torque Values	8001
9001	Special Tools	9001
9002	Consumables	9002
15001	Return to Service Following Storage	15001
15002	Refresh Charge	15003

24-32-21

LOT 1
May 19/2021



COMPONENT MAINTENANCE MANUAL
539CH2

PAGE INTENTIONALLY LEFT BLANK

24-32-21

LOT 2
May 4/2022



COMPONENT MAINTENANCE MANUAL
539CH2

INTRODUCTION

1. General

- A. This manual is written to the ATA Specification 100 and in ASD Simplified Technical English. International Standard units of measure are used in this manual, with imperial units in parentheses.
- B. This manual describes maintenance on components in a workshop. It does not describe maintenance on components when they are installed in aircraft.
- C. Only approved personnel with the necessary skills can do maintenance tasks described in this manual.
- D. This manual contains:
 - (1) Technical data for components
 - (2) Maintenance and replacement procedures for components
 - (3) An Illustrated Parts List (IPL) with data for parts of components. Parts are identified in all sections of the manual by IPL figure and item number.
- E. We make sure of DISASSEMBLY, TESTING AND FAULT ISOLATION, and ASSEMBLY procedures are correct by doing them.

The manual is divided into separate sections:

- (1) Title Page
- (2) Record of Revisions
- (3) Record of Temporary Revisions
- (4) List of Effective Pages
- (5) Table of Contents
- (6) Introduction
- (7) Procedures and IPL Sections

The disassembly and assembly sections contain only specific instructions used on the equipment covered herein. Most standard aerospace practices are not described herein.

This manual provides the information necessary for an experienced shop technician to maintain Saft nickel-cadmium batteries. It describes construction of the battery, as well as techniques used to operate, maintain, and provide care for the battery. Following these instructions will enhance the ability to obtain optimum performance and maximum life from Saft batteries.

All aircraft batteries require checking and maintenance to make sure they are safe when installed and they perform their required functions, especially in emergency conditions on-board the aircraft. Maintenance allows problems to be identified and corrected. The maintenance interval is the period for which correct operation is assured with a low probability of failure and allows elevated levels of MTBUR and MTBF.

Every effort has been made to provide complete and accurate instructions. If a situation arises that is not adequately described in this manual, please contact Saft via the internet at www.saftbatteries.com or at one of the following addresses:

24-32-21

Intro 1
Jan 23/2023



COMPONENT MAINTENANCE MANUAL
539CH2

Saft America, Inc. (09052)
711 Gil Harbin Industrial Boulevard
Valdosta, Georgia 31601, USA

Telephone: +1 (229) 247-2331
FAX: +1 (229) 247-8486

Saft (F6177)
26 quai Charles Pasqua
92300 Levallois-Perret, France

Telephone: +33 1 58 63 16 00
FAX: +33 1 58 63 16 18

2. Definitions

Warnings call attention to use of materials, procedures, or limits which must be followed precisely to avoid injury to persons.

Cautions call attention to procedures which should be followed to avoid damage to equipment.

Notes call attention to procedures which make the job easier.

3. Safety

WARNING: EXCEPT FOR THOSE STEPS THAT REQUIRE THE BATTERY TO BE CHARGED, DO ALL STEPS ON DISCHARGED BATTERIES (REFER TO [INITIAL DISCHARGE](#) AND [CELL SHORTING](#)) TO AVOID THE POSSIBILITY OF ELECTRIC SHOCK. TIGHTEN ¼ TURN VENT VALVES ([350](#)) USING [T01](#) PRIOR TO BEGINNING DISCHARGE. BATTERY CELLS DELIVER VERY HIGH CURRENT WHEN SHORT-CIRCUITED. EXERCISE CAUTION. REMOVE RINGS, WATCHES, NECKLACES, METALLIC BELTS AND OTHER JEWELRY TO AVOID ELECTRIC SHOCK.

WARNING: DO NOT TILT THE BATTERY DURING MAINTENANCE, ANY CONTACT OF SKIN WITH ELECTROLYTE CAN CAUSE SEVERE BURNS.

Safety rules differ from one country to another. Always follow local safety regulations.

There are three types of risks

A. Physical

- (1) Handling: the battery is heavy. When you lift it, bend your legs and not your back.
- (2) Use protective shoes.

B. Electrical

- (1) Do not wear rings, watches, chains, belt buckles, necklaces, or any other metallic objects.
- (2) Use insulated tools.

C. Chemical

- (1) For a complete listing of hazards, refer to the safety information sheet available on Saft's website at www.saftbatteries.com.
- (2) Electrolyte is very corrosive and can damage the skin: use gloves and an apron. If it touches the skin, flush affected part with large quantity of water. Remove contaminated clothing, after flushing begins.
- (3) Electrolyte is very dangerous for eyes, use protective goggles. If the electrolyte comes in contact with an eye, flush it with water and get immediate medical attention.

24-32-21

Intro 2
Jan 23/2023

COMPONENT MAINTENANCE MANUAL 539CH2

- (4) Saft recommends the use of an amphoteric solution (both acidic and basic behavior) and chelator (able to trap cations as a chelate complex) to neutralize electrolyte according to the local regulation.
- (5) Electrolyte ingestion can cause damage to the throat and respiratory tract. Do not try to vomit and get immediate medical attention.
- (6) Skin contact with nickel can cause chronic eczema.
- (7) Inhalation of cadmium oxide can cause dry throat, headaches, vomiting, chest pain. If inhaled, move to fresh air. If the affected person is not breathing, give artificial respiration. If breathing is difficult, give oxygen and get immediate medical attention.

4. New Battery Commissioning

Saft batteries are shipped discharged. All new Saft batteries that are receiving the initial commissioning within 12 months of the DOM refer to [Initial New Battery Commissioning](#) on page [5001](#) to place into service.

For all new Saft batteries that have not received an initial commissioning within 12 months of the DOM, then refer to [Servicing at end of long-term storage](#), [Table 15001](#).

5. Battery Ratings

A. Capacity

Nickel-cadmium batteries are rated in terms of capacity in ampere-hours (Ah) (rated capacity).

Other definitions for battery ratings can be found in EN2570, IEC 60952, and RTCA DO 293.

6. Recycling

All batteries eventually lose their ability to perform and are eligible for scrapping and recycling. Saft takes environmental matters seriously and advocates proper recycling of nickel-cadmium batteries and their components. To that end, Saft operates recycling facilities in both Europe and North America.

Nickel-cadmium batteries contain nickel, cadmium, and potassium hydroxide and should be disposed of properly. In all cases, rely on local and national regulations for proper battery disposal and/or shipping to an appropriate recycling location.



Universal Recycling Symbols
Figure Intro 1



COMPONENT MAINTENANCE MANUAL
539CH2

You can find the nearest recycling collection point on our website at www.saftbatteries.com.

7. End of Life

EASA and FAA regulations “Part 145” requires end of life cells to be disposed of in a manner prohibiting them to be returned to service. Other authorities may have requirements less explicit, Saft recommends the following procedure to be followed to provide a means of compliance.

- A. Make sure the appropriate protective measures (refer to [Safety](#) paragraph and Battery Information Sheet (BIS)) are taken.
- B. Make sure the cell is fully discharged (See [Cell shorting](#)).
- C. Break or cut the terminals from the cell. If any electrolyte leakage occurs, make sure the clean-up measures as described in the Battery Information Sheet (BIS).
- D. Dispose of the cell in accordance with applicable transport, health and safety, and recycling regulations. (Refer to [Recycling](#) paragraph)

All batteries eventually lose their ability to perform and are eligible for scrapping and recycling. Saft takes environmental matters seriously and advocates proper recycling of nickel-cadmium batteries and their components. To that end, Saft operates recycling facilities in both Europe and North America.

8. Abbreviations

A	Amperes
ASD	AeroSpace and Defence Industries Association of Europe
ATA	Air Transport Association of America
EASA	European Air Safety Authority
FAA	Federal Aviation Authority
IATA	International Transport Air Association
IEC	International Electrotechnical Commission
IMDG	International Maritime Dangerous Goods
IPL	Illustrated Parts List
Max.	Maximum
MTBF	Mean Time Between Failure
MTBUR	Mean Time Between Unscheduled Removal
P/N	Part Number
RTCA	Radio Technical Commission for Aeronautics
V	Voltage



COMPONENT MAINTENANCE MANUAL
539CH2

DESCRIPTION AND OPERATION

1. Description

The Nickel Cadmium Battery provides power either to the standby system or to start the auxiliary power unit. It is a nickel-cadmium type with sintered and plastic bonded electrode plate construction and uses a potassium hydroxide electrolyte. The battery consists of a case and cover, 20 cell assemblies and a sensor harness. The sensor harness includes a thermostat mounted on a plate against the face of the end cell of the center row of cells. A charge control thermistor is located between cells 6 and 9 in the center row of cells.

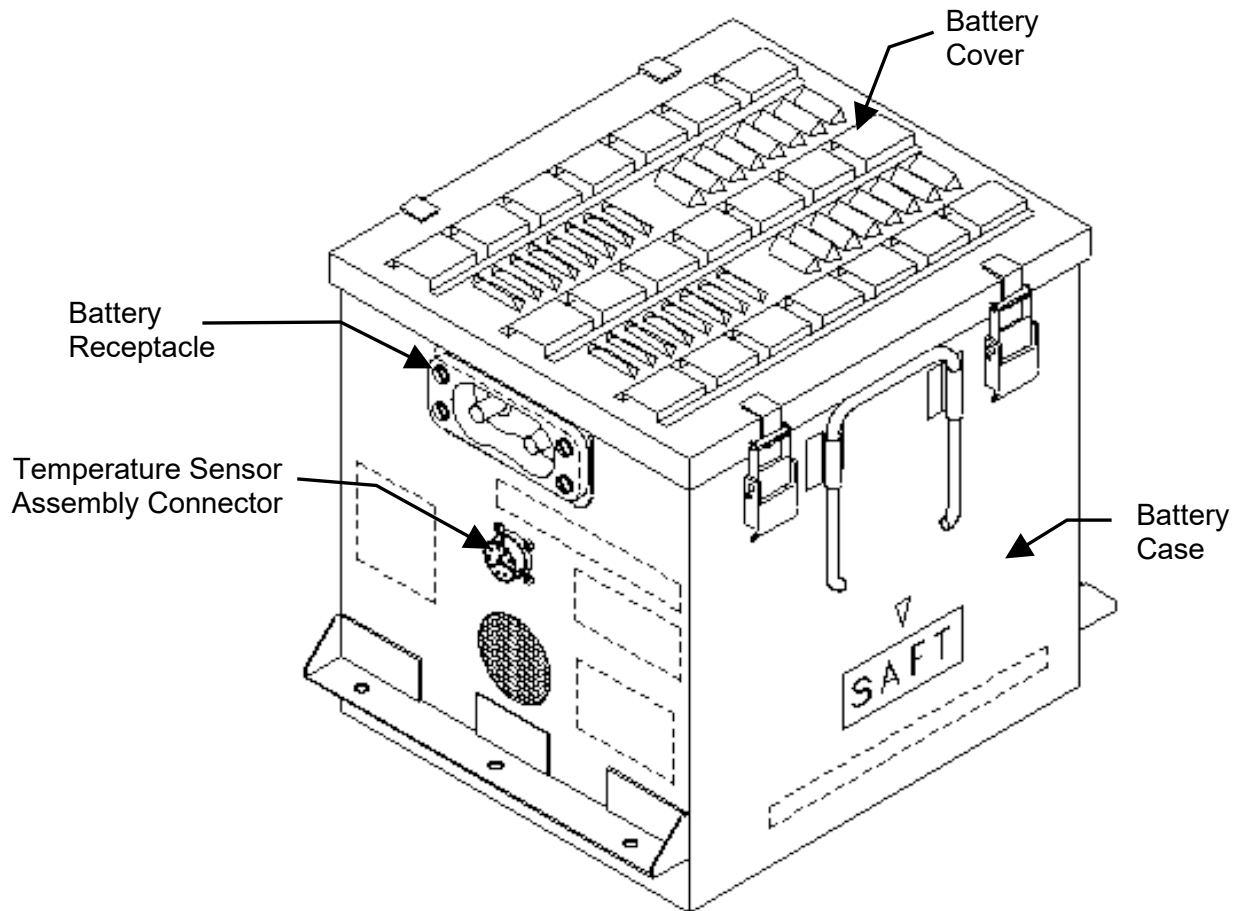

Nickel Cadmium Battery
Figure 1



COMPONENT MAINTENANCE MANUAL
539CH2

PARAMETER	VALUES
Voltage: Nominal	24.0 Volts
Weight	43.54 kg (96 pounds) maximum
Dimensions (Maximum):	
Height	289.56 mm (11.4 inches)
Length (including side brackets)	330.20 mm (13.0 inches)
Width (including handles)	279.40 mm (11.0 inches)
Cell Terminal	M10 X 1.25, externally threaded
Number of Cells	20
Cell Model	Saft-Type CVH531KA
1.0C ₁ A Rate	53.0A
0.5 C ₁ A Rate	26.5A
0.1 C ₁ A Rate	5.3A
Rated Capacity (C ₁)	53 Ampere-hours at 1.0C ₁ A
End of Life Capacity	48 Ampere-hours at 1.0C ₁ A
Maximum Consumable Water Reserve	88 cm ³ (5.37 in ³)
Venting valve	MS Style (¼ turn)
Venting Pressure	0.14 to 0.69 bar (2 to 10 psi)
Cell Case Material	Polyamide
Battery Case Material	Stainless Steel
Electrolyte	Potassium Hydroxide
Recommended Storage Temperatures	+5°C to +35°C (+41°F to +95°F)
Ambient Temperature	+15°C to +30°C (+59°F to +86°F)

Leading Particulars
Table 1

2. Operation

A. Flight charging

The battery is charged on the aircraft by an on-board charger. The charge control thermistor provides a signal to the charger to compensate the charge according to the battery temperature. The thermostat will cut off the charger if the battery temperature exceeds a safe operating limit.



COMPONENT MAINTENANCE MANUAL
539CH2

B. Maintenance

(1) Maintenance interval basis

The aircraft manufacturer and/or operator is responsible for the definition of maintenance interval based on the use profile of the batteries installed on the aircraft. The maintenance interval has two main factors:

- Energy available for emergency requirements
- Electrolyte consumable reserve.

Both factors depend on the battery charging system, operating temperature, discharge magnitude, charge cycles, flight duration, ground operation, and battery technology.

The higher voltage per cell applied, the higher overcharge current and capacity the battery receives.

The overcharged capacity is directly related to the electrolysis of water from the electrolyte, and hence the consumption of the electrolyte reserve. For every 3 Ah of overcharge, 1 cm³ (0.06 in³) of water is consumed via electrolysis. Once the water reserve has been consumed, the result is:

- Dried out cells with a significant risk of permanent damage
- Internal short circuit
- Overheating
- Thermal runaway.

(2) Maintenance interval extensions

To validate maintenance interval extension, the recommendation is to have the Operator and Saft review the maintenance records for a minimum period of 12 months.

The data includes, but is not limited to, the recording of aircraft flight hours accrued while installed, its removal date, inspection date, off-wing capacity, and water consumption as required by this CMM.

As with any maintenance extension, subsequent monitoring of the water addition and electrical performance upon removal from the aircraft must be done to detect any adverse effects and, if necessary, re-adjust the maintenance interval accordingly. To determine the electrical performance more readily after aircraft removal, the battery may be floated 31V for 1.5 hours if the aircraft uses a dedicated charger or 28.5V for 1.5 hours if it floats on the aircraft bus before performing the Initial discharge (off-wing capacity) test.



COMPONENT MAINTENANCE MANUAL
539CH2

C. Battery data requirements

Maintenance information is required for any Saft battery evaluation to determine its condition and health. Throughout this manual there are multiple steps requiring specific information be recorded to maintain a battery service history. The information provided not will only reflect the batteries airworthiness, but also provide information to assist in any battery issue investigations required at the factory. As a minimum the items identified below are required for each battery maintenance step/action.

- (1) Record the date the battery was received, and time testing started.
- (2) As required for all discharges, record the duration the first cell reaches 1.0V.
- (3) As required during charges,
 - (a) Record the cell voltages at the start of the charge, at the end of the main charge, and the last 30 minutes of the final charge.
 - (b) Record the water added to each cell during the last 30 minutes of the final charge.
- (4) As required for special testing, record location and reason for cell replacement either voltage or capacity.
- (5) Record the date the battery is returned to service.



COMPONENT MAINTENANCE MANUAL
539CH2

TESTING AND FAULT ISOLATION

1. General

This section contains battery functional tests and fault isolation information. Test procedures are written in step-by-step formats that follow the process flow outlined in [Figure 1001](#). Fault isolation is presented in chart form to identify faults, possible causes, and remedies, refer to [Table 1006](#), [Table 1007](#), or [Table 1008](#).

NOTE: The () part identification numbers herein are [IPL Figure 1](#) item numbers.

NOTE: All voltage readings are DC unless otherwise stated.

2. Required Test Equipment

NOTE: Test equipment with equivalent specifications can be used.

Refer to [Special Tools, Fixtures, Equipment, and Consumables](#) for listing of Standard Tools.

3. Maintenance Procedures

In addition to the checks specified for airborne or ground use, in normal service SAFT 539CH2 batteries require the following maintenance operations.

A. Restoration Procedure

Outlined in [Figure 1001](#) is a step-by-step process flow required. A request for overhaul or restoration should follow this same procedure.

NOTE: Overhaul by some airworthiness authorities is defined as an item that has been disassembled, cleaned, inspected, repaired as necessary, reassembled, and tested. To identify this process the entire battery must require total disassembly, thorough cleaning, inspection, assembly, and testing.

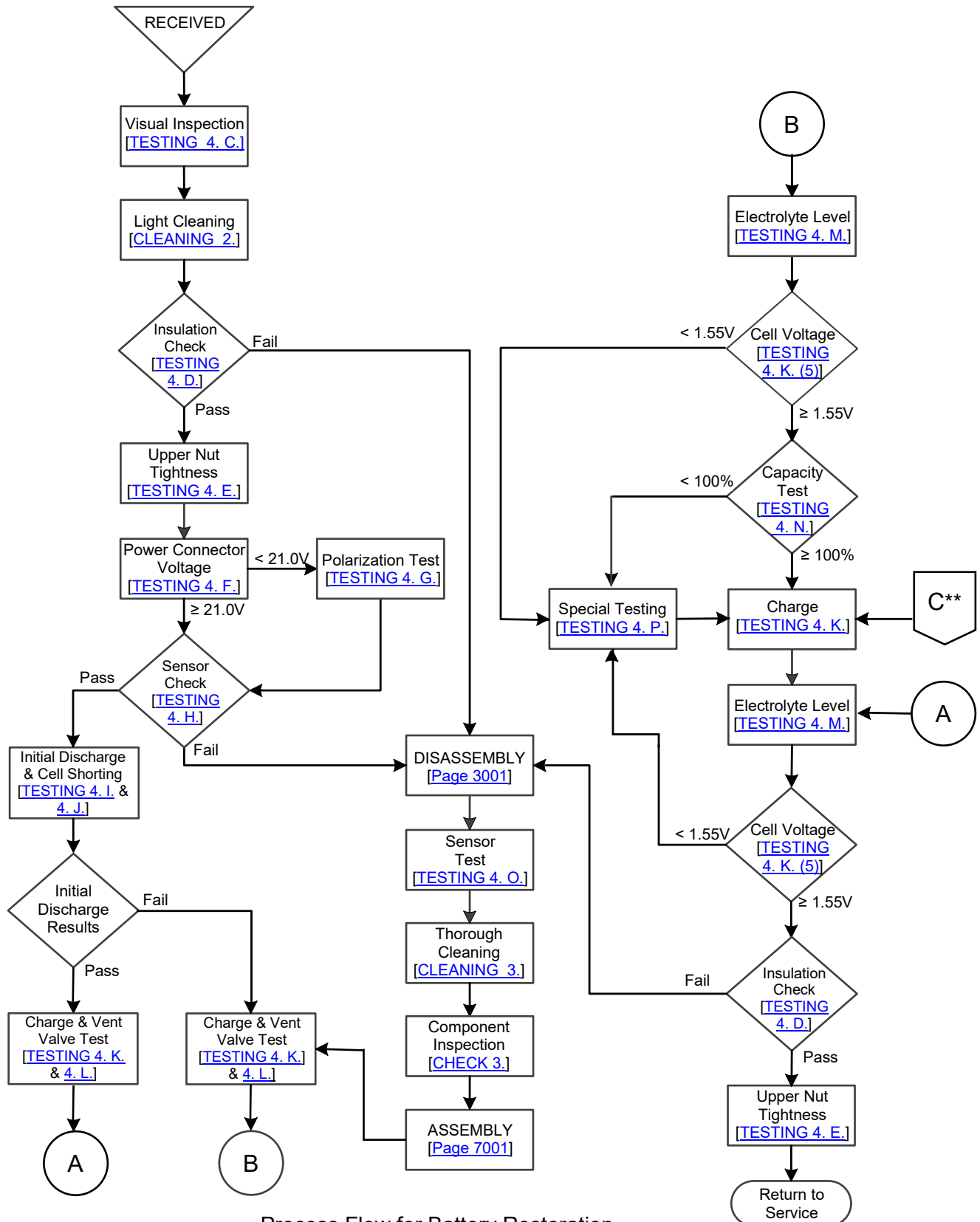

Process Flow for Battery Restoration
Figure 1001

**Table 15001

24-32-21



COMPONENT MAINTENANCE MANUAL
539CH2

4. Testing

A. Test conditions

(1) Facilities and equipment

CAUTION: FUMES FROM LEAD ACID BATTERIES OR SMALL TRACES OF SULFURIC ACID ENTERING A NI-CD BATTERY CAN CAUSE PERMANENT DAMAGE.

- (a) Service facilities for Ni-Cd batteries must be entirely separate from those for lead acid batteries.
 - (b) Equipment used to service lead acid batteries must not be used to maintain Ni-Cd batteries.
- (2) For optimum results conduct all tests with the battery temperature at Ambient Temperature, unless otherwise noted in this manual.

B. Test equipment

Refer to [Special Tools, Fixtures, and Equipment, and Consumables](#) for test equipment recommendations.

C. Visual Inspection

Items found may require doing immediate disassembly while the majority do not. If a finding does not require going to disassembly procedure, then specific instructions are provided after the battery has been received its initial discharge.

- (1) Visually inspect battery cover ([020](#)) for dents, distortion, or other damage and replace as needed with new Saft component.
- (2) Visually inspect battery case ([010](#)) for dents, distortion, or other damage. If found, identify the case for replacement.
- (3) Remove hold-down pad ([030](#)) and formed insulator ([040](#)) and visually inspect each for any evidence of damage or distortion, replace as needed with new Saft component.
- (4) Visually inspect the visible portions of each cell ([260](#)) for any evidence of electrolyte leakage or damage.
 - (a) Damaged cells ([260](#)) must be identified for replacement or further cleaning.

NOTE: Excessive electrolyte leakage will cause the battery to fail the Battery insulation test.

- (b) Excessive salts around the terminal posts gives an indication of possible terminal O-ring ([270](#)) leakage. Identify any cells with excessive salts for later torquing the lower nut ([320](#)).
- (c) When inspection reveals electrolyte leakage from the cell at the vent hole opening, replace the defective O-ring ([360](#)) as follows:

WARNING: USE CARE NOT TO TILT CELLS WHILE VENT VALVES ARE OPEN OR REMOVED; CONTACT OF ELECTROLYTE WITH CAN CAUSE SEVERE BURNS.

- 1 Using [T01](#), loosen and remove the ¼ turn vent valve ([350](#)) from the cell ([260](#)).

24-32-21

1003
Jan 23/2023



COMPONENT MAINTENANCE MANUAL
539CH2

- 2 Remove and replace defective O-rings (360) from the vent valve (350).
 - 3 Using T01, tighten the ¼ turn vent valve (350) onto the cell (260).
- (5) Inspect the upper nuts (120), (340), washers (110), (330), and links (140 to 180) to ensure it is free of bends, tarnish, corrosion, burns, or loss of plating. Minor tarnish can be polished off with a fine wire brush. Identify defective hardware for later replacement.
 - (6) Check all ventilation openings to make sure that they are clean and clear.
 - (7) Inspect the power connector (090) pins for defects, evidence of arcing or excessive oxidization. If observed, identify the power connector (090) for later replacement.

D. Battery insulation

NOTE: A breakdown in electrical insulation between the cells and the battery case will result in a “leakage” current, which, over a period of time, can discharge the battery.

NOTE: Method A or B may be used to check the insulation breakdown.

(1) Method A

- (a) Set up the multimeter and meter leads for a measurement of 250mA.
- (b) Connect the negative lead from the meter to the battery container then touch the positive lead from the meter to :
 - 1 the positive terminal of each cell.,
- (c) If there is a reading of zero, the insulation test is a “Pass”; otherwise, the insulation test is a “Fail”.

NOTE: If, after cleaning the battery and assuring that everything is dry, a leakage current is still indicated by a reading other than zero, then one or more cells (260) is defective. Isolate and replace the defective cell(s).

(2) Method B

- (a) On a completely assembled battery using megohmmeter under a continuous 250V, measure the insulation resistance between the metal box and
 - 1 the positive terminal of each cell.
- (b) The value measured must be $\geq 10M\Omega$ while under 250V continuous.
- (c) If the reading meets the above criteria ($\geq 10M\Omega$), the insulation is a “Pass”; otherwise, the insulation test is a “Fail”.

NOTE: If, after cleaning the battery and assuring that everything is dry, the resistance is still $< 10M\Omega$, one or more cells (260) is defective, isolate and identify for later replacement.

E. Upper nut tightness

Check the tightness on each upper nut (120), (340) per [Table 8001](#).

F. Battery voltage

Measure and verify the voltage at the battery power connector (090) is greater than or equal to 21.0V.

24-32-21

1004
Jan 23/2023

COMPONENT MAINTENANCE MANUAL 539CH2

G. Polarization Test

- (1) Charge the battery at $0.1C_1$ for 1.5 hours.
- (2) Keep the battery in open circuit for 1 hour.
- (3) Measure the open circuit voltage of each cell (260).
 - (a) Identify for replacement any cell (260) with zero volts or negative polarity. If any cell (260) is identified for replacement, the polarization test is a "Fail".
 - (b) If all cells are above zero volts, the polarization test is a "Pass".

H. Sensor harness check

NOTE: A climate chamber or alternate methods may be used provided the temperatures below are achieved.

NOTE: This check may be substituted with the paragraph [Sensor harness test](#) by assuming the check is a "Fail" and returning to [Figure 1001](#).

The harness should be tested on a biennial basis instead of doing this check (see [Sensor harness test](#))

NOTE: Refer to [Figure 1002](#) for pinout locations.

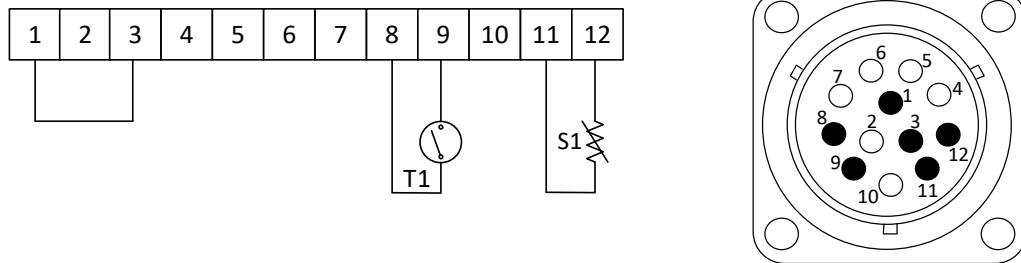

Connector Pinout
Figure 1002

- (1) If any part of the sensor harness (190) is damaged, the entire assembly must be replaced after disassembly.
- (2) Be sure the internal battery temperature is at $+22.8^{\circ}\text{C} \pm 5.0^{\circ}\text{C}$ ($+73^{\circ}\text{F} \pm 9^{\circ}\text{F}$). Test with an ohmmeter to auxiliary connector (240) per [Table 1001](#) on connector sensor harness (190). Any erratic or incorrect readings represents a failure and the entire assembly (190) must be replaced after disassembly.

ITEM	PINS	VALUES @ $+22.8 \pm 5^{\circ}\text{C}$ ($+73 \pm 9^{\circ}\text{F}$)
-	1 to 3	$<1\text{M}\Omega$
S1 (210)	11 to 12	1854Ω to 3116Ω
T1 (200)	8 to 9	$\geq 20\text{M}\Omega$

Sensor Harness Check Values
Table 1001

I. Initial discharge (off-wing capacity)

The purpose of this procedure is to discharge the battery to a known state of charge and determine the battery capacity from the aircraft.

- (1) Using [T01](#), verify the $\frac{1}{4}$ turn vent valve ([350](#)) is tightened on each cell ([260](#)).



COMPONENT MAINTENANCE MANUAL
539CH2

- (2) Discharge the battery at a rate listed in [Table 1002](#) until the battery reaches 20.0V and record the times the first cell reaches 1.0V and battery reaches 20.0V.

NOTE: It is important that the discharge current be continually maintained at the selected value, and that the time of discharge be measured accurately.

NOTE: If a cell goes to zero volts or reverses polarity during the discharge, short out the cell's terminals for the remainder of the discharge.

DISCHARGE		MINIMUM TIME FOR FIRST CELL TO 1.0V
RATE (C1)	CURRENT (AMPS)	
0.5	26.5	122.0 MINUTES
1.0	53.0	60.0 MINUTES
Initial Discharge (Off-wing Capacity) Table 1002		

- (3) If defective case ([010](#)), power connector ([090](#)), nuts ([120](#)), ([340](#)), washers ([110](#)), ([330](#)), or links ([140](#) to [180](#)) were identified for replacement, they are to be corrected by performing the appropriate [DISASSEMBLY](#) and [ASSEMBLY](#).
- (4) For each cell ([260](#)) identified for replacement, do [Cell replacement](#) in [REPAIR](#).
- (5) For each cell ([260](#)) with excessive salts around the terminals during visual inspection, do [Lower nut tightness](#).
- (6) If any cell hardware ([280](#)), ([290](#)), ([300](#) or [310](#)), ([320](#)) was identified as needing replacement, do [Cell hardware replacement](#) in [REPAIR](#).
- (7) If terminal O-ring ([270](#)) requires replacement, do [Terminal O-ring replacement](#) in [REPAIR](#).
- (8) Initial discharge results

NOTE: The results below will be used for a decision point in [Figure 1001](#).

- (a) If the discharge time the first cell reaches 1.0V equals or exceeds the value shown in [Table 1002](#) for the discharged rate, the battery capacity is a "Pass".
- (b) If the discharge time the first cell reaches 1.0V is less than the value shown in [Table 1002](#) for the discharged rate, the battery capacity is a "Fail".

J. Cell shorting

- (1) Using [T01](#), verify the ¼ turn vent valve ([350](#)) is tightened on each cell ([260](#)).
- (2) Discharge each cell in the battery to 0V using one of the two methods below:

NOTE: It is not necessary to have a rest period between a discharge and cell shorting.

(a) Method A

- 1 Continue to discharge the battery per [Table 1002](#) until each cell is < 1.0V, connect a [T03](#) across its terminals. After all the cells have been shorted, leave the devices in place for 12 to 24 hours.



COMPONENT MAINTENANCE MANUAL
539CH2

(b) Method B

- 1 Continue to discharge the battery per [Table 1002](#) until each cell is < 0.5V, then connect a shorting clip across its terminals. After all the cells have been shorted, leave these clips on for 16 to 24 hours.
- (3) At completion of Method A or B, remove the shorting devices.
- (4) If no cell(s) are identified for replacement, then return to [Figure 1001](#) utilizing the “Pass” or “Fail” results of the [Initial discharge](#).
- (5) If any cell ([260](#)) was identified for replacement, do [Cell replacement](#) in [REPAIR](#).

K. Charge

- (1) Allow the battery to cool to ambient temperature.
- (2) Remove the cover ([020](#)), pad ([030](#)) and formed insulator ([040](#)),
- (3) Prior to charging the battery, loosen (do not remove) all ¼ turn vent valves ([350](#)). Ensure that the shorting spring has been removed.

NOTE: If required by [Figure 1001](#), it is recommended to do [Vent valve test](#) during the charge.

- (4) Charge the battery using one of the methods in [Table 1003](#).
 - (a) Record the cell voltages at the start and end of the main charge (Step 1), and the last 30 minutes of the final charge (Step 2).
 - 1 If the start cell voltage of the main charge (Step 1) goes above 1.50V, add to the cell about 10 cm³ (0.61 in³) of [M01](#).
 - 2 During the last during the last 30 minutes of the final charge (Step 2), adjust the [Electrolyte level](#), and check the [Minimum final charge voltage](#).

Main Charge (Step 1)			Final Charge (Step 2)**
Current	Minimum Time*	End of Main Charge Criteria	Current and Time
0.1C ₁ A (5.3A)	10h	Every cell >1.5V or 12h*** whichever comes first	0.1C ₁ A (5.3A) for 4h
0.5C ₁ A (26.5A)	2h	Every cell >1.55V or 2.5h*** whichever comes first	0.1C ₁ A (5.3A) for 4h
1.0C ₁ A (53.0A)	1h	Every cell >1.57V or 1.25h*** whichever comes first	0.1C ₁ A (5.3A) for 4h

* Minimum time applies to a battery previously discharged to 20.0V.

** During the last 30 minutes do [Electrolyte level](#) and confirm minimum voltage criteria in [Table 1004](#).

*** New batteries may take 20% longer than the maximum time provided to reach the proper cell voltages.

Charge Table
Table 1003



COMPONENT MAINTENANCE MANUAL
539CH2

(5) Minimum final charge voltage

During the last 30 minutes of final charge (Step 2), measure and verify the voltage of each cell (260) meets the value shown in [Table 1004](#). Identify each cell that does not comply.

CELL VOLTAGE (Last 30 minutes at 0.1C ₁ A)
≥ 1.55V

Final Charge Voltage Limit
Table 1004

L. Vent valve test

NOTE: The vent valve test should be done once a year of battery operation or every maintenance interval, whichever is longer. This test is not necessary if all the vent valves (350) are replaced with new Saft valves each year or maintenance interval, whichever is longer.

NOTE: It is recommended to do this test while the battery is on charge.

CAUTION: THE CELL OPENINGS MUST BE COVERED WITH A CLEAN, DAMP CLOTH TO PREVENT ENTRY OF FOREIGN MATTER.

(1) Check the operation of the vent valve (350) as follows:

- Using [T01](#), install ¼ turn vent valve (350) that contains O-ring (360) onto the [T05](#) fixture.
- Attach the fixture [T05](#) to a compressed air line through an adjustable pressure reducing valve limited to 1.38 bar (20 psi).
- Slowly raise the air pressure to a 1.38 bar (20 psi) maximum to test the functionally below.
- Immerse the valve and end of fixture in water, and slowly raise the pressure. Make sure the valve opens between 0.14 to 0.69 bar (2 psi and 10 psi).
- Reuse only those vent valves found to open in the 0.14 to 0.69 bar (2 psi and 10 psi) range. Re-soak vent valves that do not open at 0.69 bar (10 psi) until they do open (refer to [CLEANING](#) on page [4001](#)). Discard vent valves which are not gas tight at low pressure.

M. Electrolyte level

This procedure is to be carried out during the last 30 minutes of the final charge (Step 2) at 0.1C₁A.

WARNING: USE CARE NOT TO TILT CELLS WHILE VENT VALVES ARE LOOSENED OR REMOVED; CONTACT OF ELECTROLYTE WITH SKIN CAN CAUSE SEVERE BURNS.

CAUTION: USING ANYTHING OTHER THAN [M01](#) IN NICKEL-CADMIUM CELLS WILL CAUSE ELECTROLYTE CONTAMINATION AND DAMAGE. DO NOT RE-USE WATER REMOVED FROM CELLS.

COMPONENT MAINTENANCE MANUAL 539CH2

- (1) Remove the ¼ turn vent valves (350) with T01, taking precautions to prevent foreign substances from entering the cell.
 - (a) Clean the vent valves (350) by immerse the valves and their O-rings (360) in M01 and let them soak to dissolve any salts.
- (2) Inserting T02 into the cell opening until the shoulder of the nozzle rests on the valve seat, see Figure 1003.

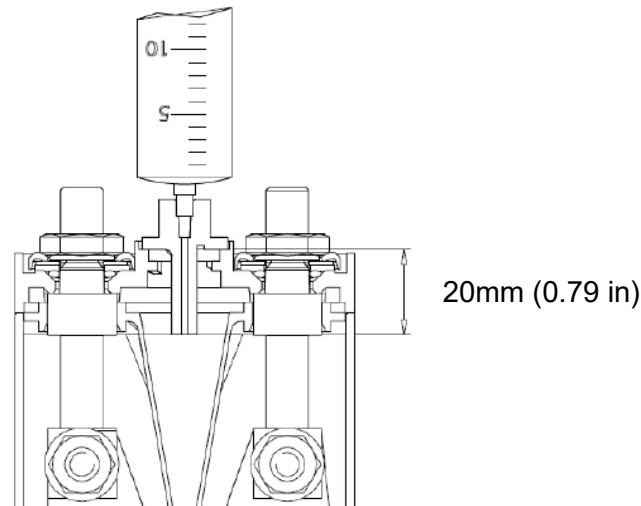

Position of T02 in Cell Vent Seat
Figure 1003

- (3) Withdraw the plunger and check for any liquid in the T02.
 - (a) Any excess liquid in the cell will be drawn into the syringe until the electrolyte is level is correct.
 - (b) If the liquid level is too low, the syringe will remain empty, indicating that the end of the syringe nozzle did not reach the liquid in the cell.

NOTE: If the quantity of water added per cell exceeds 88 cm³ (5.37 in³), then check the charging system. If the aircraft charging system is functioning properly, the maintenance period may need be reduced.

- 1 Draw a measured amount of M01, such as 5 cm³ (0.31 in³) into the T02 and inject it into the cell.
 - 2 With the syringe nozzle resting on the valve seat, slowly withdraw the plunger into T02.
 - 3 If T02 remains empty, repeat steps 1 and 2, counting the total number of cm³ required to achieve the correct level.
 - 4 At the point in step 2 when some excess liquid is drawn into T02, the correct level for that cell has been reached. Expel the excess liquid into a separate container for proper disposal of hazardous waste.
 - 5 Record the amount of water added/removed from each cell in the battery logbook or battery test sheet.
- (4) Using T01, tighten the ¼ turn vent valve (350) is tightened on each cell (260)



COMPONENT MAINTENANCE MANUAL
539CH2

N. Capacity check (second discharge)

The purpose of this discharge procedure is to verify minimum battery capacity.

- (1) Prior to doing the capacity check, do [Charge](#) and [Electrolyte level](#).
- (2) Using [T01](#), verify the ¼ turn vent valve ([350](#)) is tightened on each cell ([260](#)).
- (3) Discharge the battery at one of the current rates shown in [Table 1005](#) until the battery reaches 20.0V to determine and record the times the first cell reaches 1.0V and battery reaches 20.0V.

NOTE: It is important that the discharge current be continually maintained at the selected value, and that the time of discharge is measured accurately.

NOTE: If a cell goes to zero volts or reverses polarity during the discharge, short out that cell's terminals with a [T03](#) for the remainder of the discharge.

DISCHARGE		MINIMUM TIME FOR FIRST CELL TO 1.0V
RATE (C ₁)	CURRENT (AMPS)	
0.5	26.5	113.7 MINUTES
1.0	53.0	56.6 MINUTES

Capacity Check (Second Discharge)
Table 1005

- (4) If the time the first cell reached 1.0V equals or exceeds the values shown in [Table 1005](#) at the discharge rate, then the capacity is ≥ 100%. Allow the battery to rest at least 2 hours.
- (5) If the time the first cell reached 1.0V is less than the value shown in [Table 1005](#) at the discharge rate, then the capacity is < 100%.

O. Sensor harness test

This test shall be done for a [Battery insulation](#) check failure or disassembly, otherwise the test should be done on a biennial basis by doing [DISASSEMBLY](#) to allow the harness to be removed and tested.

WARNING: A FULLY ASSEMBLED BATTERY MUST BE IN A FULLY DISCHARGED CHARGE STATE TO PREVENT INJURY, REFER TO [CELL SHORTING](#).

NOTE: A climate chamber or alternate methods may be used, provided the temperatures below are achieved.

If any part of the sensor harness ([190](#)) is damaged or fails any portion of this test, the entire assembly must be replaced with new Saft sensor harness ([190](#)).

NOTE: Refer to [Figure 1002](#) for pinout locations.

- (1) Confirm the battery was discharged and disassembled.
- (2) Over Temperature Thermostat ([200](#)) is part of sensor harness ([190](#)). It is attached to the thermostat mounting plate ([060](#)). Disassembly is required in order to test the thermostat (refer to [DISASSEMBLY](#)).
- (3) Test with an ohmmeter the connector sensor harness ([190](#)) per [Table 1001](#). Any erratic readings represent a failure.



COMPONENT MAINTENANCE MANUAL
539CH2

- (4) Thermostat (200) functional testing as follows:
 - (a) Suspend the thermostat mounting plate shown in (060) with thermostat (200) in a beaker of water. Position the thermostat a minimum of 50.8mm (2 in) from the bottom and 25.4mm (1 in) from the top of the water surface.
 - (b) Insert a thermometer, or other suitable temperature-measuring device, in the water with the bulb adjacent to the thermostat.
 - (c) Slowly raise the water temperature to +66°C (+150°F) while observing the ohmmeter. Make sure contacts remain open ($\geq 20M\Omega$) at temperatures below +66°C (+150°F).
 - (d) Continue raising the water temperature and stabilize at 71°C \pm 5.0°C (160°F \pm 9°F), then make sure the thermostat closes ($< 10\Omega$) at a stabilized temperature of 71°C \pm 5.0°C (160°F \pm 9°F).
 - (e) Slowly add cool water to the beaker to reduce water temperature to 65°C \pm 2.8°C (149°F \pm 5°F). Make sure the thermostat opens ($\geq 20M\Omega$) within 6.1°C (11°F) of the closing temperature.
 - (f) If the thermostat fails to meet any of the above criteria, then replace with Saft new sensor harness (190).
- (5) Charge Control Thermistor is permanently mounted on a sensor plate (210). Check the function of the unit as follows:
 - (a) Immerse the thermistor plate in a beaker containing a mixture of ice and water.
 - (b) Insert a thermometer, or other suitable temperature-measuring device, in the container, in contact with the plate.
 - (c) Make sure the ohmmeter indicates 7355 \pm 672 Ω when the plate temperature is 0°C \pm 1.7°C (+32°F \pm 3°F).
 - (d) After the low temperature test, slowly raise the temperature to +71°C \pm 2.8°C (+160°F \pm 5°F).
 - (e) Make sure the ohmmeter indicates 382 \pm 23 Ω when the plate temperature is +71 \pm 1.7°C (+160 \pm 3°F).
 - (f) If the thermistor fails any of the above testing criteria, replace with new Saft sensor harness (190).



COMPONENT MAINTENANCE MANUAL
539CH2

P. Special testing

These procedures are to be followed for a battery that does not meet capacity or if the end of charge cell voltage < 1.55V during the final charge. Refer to [Figure 1004](#) flow chart.

NOTE: For a new battery or one removed from the aircraft that has not passed capacity after doing the Special Testing more than 3 times, it is recommended to replace noncompliant cells with new Saft cells ([260](#)), refer to [All cell replacement](#) recommendation in [REPAIR](#).

NOTE: For battery from long-term storage, several complete charge/discharge cycles may be needed to restore performance.

(1) Special testing decision

For a battery with < 100% capacity, do [Low capacity \(Special testing\)](#). Otherwise, for a battery with any cell voltage < 1.55V do [Supplementary test](#).

(2) Low capacity (Special testing)

(a) Loosen, but do not remove all ¼ turn vent valves ([350](#)) and fully charge the battery as outlined in [Charge](#).

(b) For a battery containing any cell voltage < 1.55V during the final charge, do [Supplementary test](#). Otherwise, do [Capacity test \(Special testing\)](#).

(3) Supplementary test

(a) Charge at 0.1C₁A for an additional 5 hours and monitor the voltage of the individual cells every 30 minutes.

NOTE: The additional 0.1C₁A 5-hour charge may be stopped once all the cells are ≥ 1.55V.

1 Identify for replacement any cell ([260](#)) with voltage < 1.55V.

2 During the last 30 minutes of this charge, adjust the [Electrolyte level](#).

3 Do [Cell replacement](#) in [REPAIR](#) for cells identified for replacement. Otherwise do [Capacity test \(Special testing\)](#).

NOTE: If more than one cell ([260](#)) was replaced due to low charge voltage during the current maintenance cycle, then the replacement of all cells should be considered. Refer to [Cell replacement](#) in [REPAIR](#).

(4) Capacity test (Special testing)

(a) Using [T01](#), verify the ¼ turn vent valve ([350](#)) is tightened on each cell ([260](#)).

(b) Discharge the battery at a rate shown in [Table 1005](#) until the battery reaches 20.0V. Record the time and current the battery reached 20.0V and identify the noncompliant cells with voltage less than 1.0V.

(c) If the time the first cell reached 1.0V equals or exceeds the values shown in [Table 1005](#) at the applicable discharge rate, then return to [Figure 1001](#). Otherwise, repeat this procedure [Low capacity \(Special testing\)](#) or refer to [Fault Isolation](#).

1 For noncompliant cells that failed this capacity test 3 times, replace with new Saft cells ([260](#)), refer to [Cell replacement](#) in [REPAIR](#)

COMPONENT MAINTENANCE MANUAL

539CH2

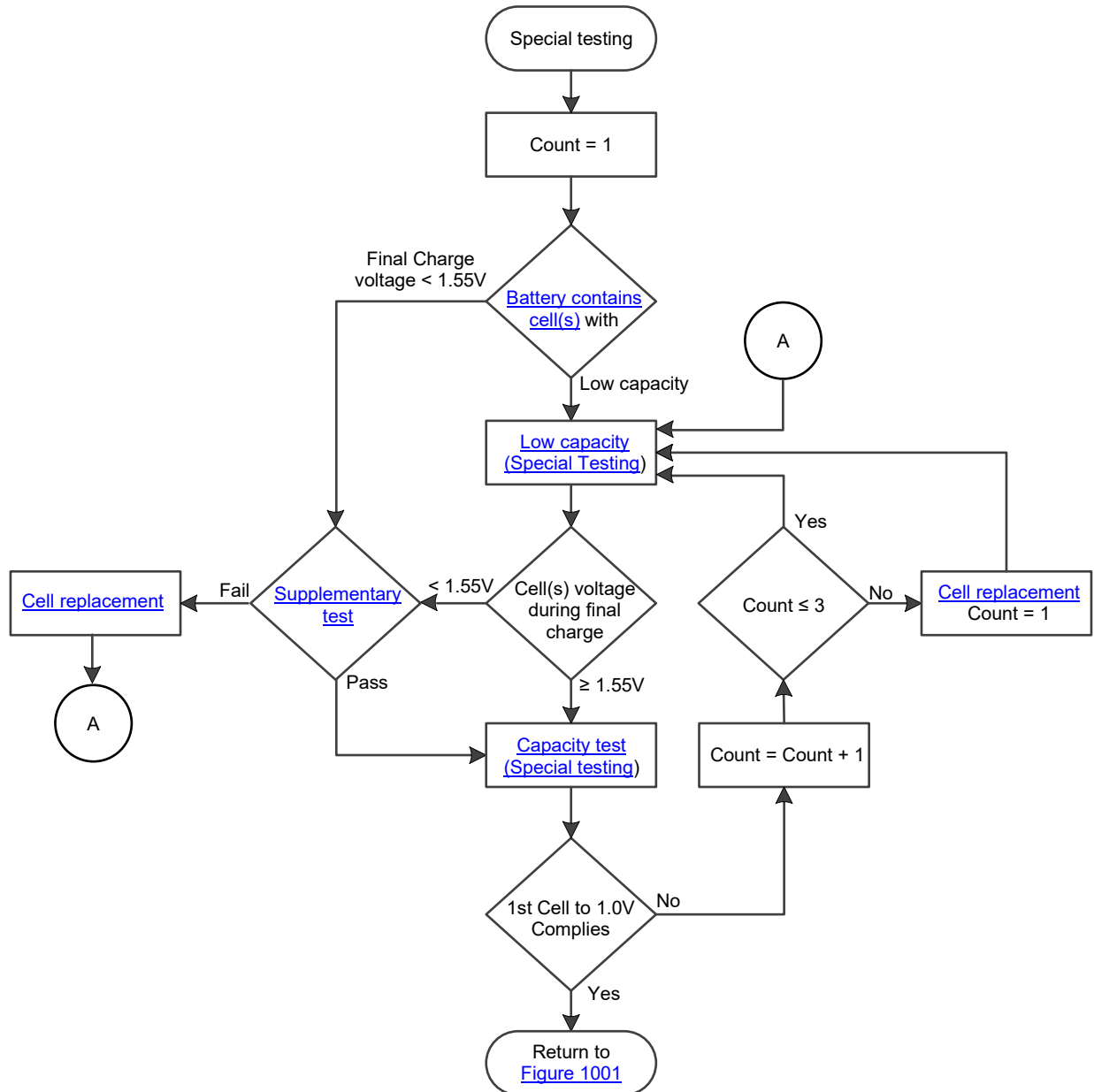

Special Testing Flow Chart
Figure 1004

Q. Lower nut tightness

- (1) Remove the necessary hardware; upper nuts (120), (340) and washers (110), (330) that attach the links (140 to 180) to confirm the lower nut (320) tightness per Table 8001.
- (2) Install the necessary hardware, links (140 to 180), washers (110), (330), and upper nuts (120), (340). Torque upper nuts (120), (340) per Table 8001.



COMPONENT MAINTENANCE MANUAL
539CH2

5. Fault Isolation

Fault isolation information is presented in [Table 1006](#) , [Table 1007](#), or [Table 1008](#) as a guide to locate the cause of malfunction and isolating the cause to a specific component.

TROUBLE	PROBABLE CAUSE	REMEDY
(1) No battery voltage	(a) Defective electrical connector (not making contact). (b) Broken or loose terminal links	Check electrical contacts, links Replace if required using DISASSEMBLY and ASSEMBLY
(2) Low Insulation	(a) Leakage of electrolyte (b) Incorrect electrolyte level (c) Reverse cell polarity (d) Condensation / Contamination (e) Improper cleaning (f) Loose or damage vent valve (g) Damaged cell case (h) Charge rate too high	Do Thorough Cleaning , ASSEMBLY , Charge , Electrolyte level Tighten or replace ¼ turn vent valve, do Thorough Cleaning , ASSEMBLY , Charge , Electrolyte level Do Thorough Cleaning , Cell replacement , ASSEMBLY , Charge , Electrolyte level Investigate the cause of the excessive charge. Do Thorough Cleaning , ASSEMBLY , Charge , Electrolyte level
(3) Loss of battery capacity	(a) Normal wear after long service (b) Exceptionally heavy use	Do Special testing

Battery Faults
Table 1006



COMPONENT MAINTENANCE MANUAL
539CH2

TROUBLE	PROBABLE CAUSE	REMEDY
(1) Cell water consumption is above the maximum allowed	(a) Charged more than allowed or charged at high temperature. (b) Previous maintenance has not been done (c) Maintenance interval too long	Examine the cause of the excessive charge. Do Charge , and Electrolyte level be sure what for the next maintenance interval. If this continues the maintenance interval should be done reduced.
(2) High water consumption in one or more cells	(a) Damaged separator when the water consumption is less than 30% below the average value of added water in all cells. (b) Cell imbalance when water addition is more than 30% above the average value of added water in all cells.	Do Charge , Supplementary test . Do Thorough Cleaning , Cell replacement , ASSEMBLY , Charge , Electrolyte level
(3) Abnormally high cell voltage at beginning of charge	(a) Dry cell	Add 5 to 10 cm ³ (0.31 to 0.61 in ³ of distilled water, do Electrolyte level
(4) Zero Voltage on cell	(a) Short-circuited cell	Do Cell replacement
(5) Low cell voltage at end of charge	(a) Separator damage	Do Cell replacement
(6) Low cell capacity	(a) Normal wear from long service	Do Cell replacement
(7) Cell with a swollen case	(a) Cell operated with low electrolyte level, deterioration of separator and damaged plates	Do Cell replacement

Cell Faults
Table 1007



COMPONENT MAINTENANCE MANUAL
539CH2

TROUBLE	PROBABLE CAUSE	REMEDY
(1) Tarnished or burned terminal connectors	(a) Loose terminal nuts and links	Clean and torque per Table 8001
(2) Exposed copper material on power connector pin	(a) Mechanical damage (b) Electrical arcing	Replace component using DISASSEMBLY and ASSEMBLY
(3) Melted plastic on connectors	(a) Overheat due to contact resistance	Replace component using DISASSEMBLY and ASSEMBLY
(4) Corroded links	(a) Operation in acidic atmosphere (b) Inadequate greasing (c) Mechanical damage to protective nickel-plating	Check room eliminate acid source, replace component using DISASSEMBLY and ASSEMBLY Replace component using DISASSEMBLY and ASSEMBLY Replace component using DISASSEMBLY and ASSEMBLY
(5) Battery case and cover damage with dents, deformations, and visible cracks which affect fit or impede performance.	(a) Various, transport (b) Mechanical stress, drop	Replace component using DISASSEMBLY and ASSEMBLY

Physical Faults
Table 1008



COMPONENT MAINTENANCE MANUAL
539CH2

DISASSEMBLY

1. General

This section provides step-by-step instructions on disassembling the complete battery.

NOTE: The () part identification numbers herein are [IPL Figure 1](#) item numbers.

2. Detailed Instructions

WARNING: BATTERY CELLS DELIVER VERY HIGH CURRENTS WHEN SHORT-CIRCUITED. EXERCISE CAUTION. REMOVE RINGS, WATCHES OR OTHER JEWELRY FROM HANDS AND ARMS.

WARNING: BATTERY MUST BE COMPLETELY DISCHARGED BEFORE CELL ASSEMBLIES CAN BE REMOVED DUE TO POSSIBILITY OF ELECTRIC SHOCK.

WARNING: USE CARE NOT TO TILT BATTERY WHILE ¼ TURN VENT VALVES ARE LOOSENED; CONTACT OF ELECTROLYTE WITH SKIN CAN CAUSE SEVERE BURNS.

A. Preparation

- (1) Discharge the battery at one of the current rates shown in [Table 1005](#) until each cell reaches 1.0V.
- (2) Remove cover ([020](#)), hold-down pad ([030](#)) and insulator ([040](#)) by opening latches and lifting cover from case ([010](#)).
- (3) Do [Cell shorting](#)

B. Cell ([260](#)) Removal

- (1) Remove nuts ([340](#)), ([120](#)), and washers ([330](#)), ([110](#)) from terminals of cells ([260](#)) and terminals of the terminal adapter connector ([090](#)).
- (2) Remove intercell terminal links ([140](#) through [180](#)) from terminals of cells ([260](#)).
- (3) Using [T04](#) remove cell assemblies ([260](#)) from the battery case ([010](#)) by tightening [T04](#) to cell terminals and removing cell with a steady straight up pull.

C. Disassembly of the cells ([260](#)) is restricted to replacing defective O-rings ([270](#)) of the cell terminal seals. Refer to [Cell hardware replacement](#) in [REPAIR](#).

D. Power connector ([090](#)) removal

- (1) Remove screws ([100](#)) from the connector.
- (2) Remove power connector ([090](#)) and its gasket ([130](#)) from the battery case ([010](#)).



COMPONENT MAINTENANCE MANUAL
539CH2

- E. Sensor harness ([190](#)) removal
 - (1) Remove the thermostat mounting nuts ([257](#)) from the thermostat plate ([060](#)).
 - (2) Remove the thermostat plate ([060](#)) and thermostat spacers ([057](#)) from the battery case ([010](#)).
 - (3) Remove the sensor harness connector mounting screws ([250](#)), nuts ([257](#)) and lift the sensor harness ([190](#)) out of the battery case ([010](#)).
- F. Remove all spacers ([050](#)) from the battery case ([010](#)).

24-32-21

3002
May 4/2022



COMPONENT MAINTENANCE MANUAL
539CH2

CLEANING

1. General

CAUTION: DO NOT USE PETROLEUM SPIRITS, TRICHLOROETHYLENE OR OTHER SOLVENTS FOR CLEANING THE BATTERY. USE OF THESE PRODUCTS MAY DETERIORATE THE INTEGRITY OF METAL PARTS.

NOTE: The () part identification numbers herein are [IPL Figure 1](#) item numbers.

- A. The following items are required for cleaning procedures (equivalent substitutes can be used):
- Stiff bristled brush (nonmetallic)
 - Dry compressed air source, less than 1.38 bar (20 psi)
 - Safety goggles
 - Lubricant, non-acid petroleum jelly, [M02](#)
 - Soft, clean cloth (two required)
 - Running water
 - Mild soap, [M03](#)
 - Distilled or de-ionized water, [M01](#)

2. Light Cleaning

- A. The following procedures are for an assembled battery with battery cover ([020](#)), hold down pad ([030](#)), and formed insulator ([040](#)) removed.
- B. Using [T01](#), make sure the ¼ turn vent valve ([350](#)) of each cell ([260](#)) is closed and secure. Do not over-tighten.

CAUTION: DO NOT USE A WIRE BRUSH TO CLEAN CELL TOPS. CELLS MAY BE DAMAGED.

- C. Remove white deposits (potassium carbonate) from tops of all cell assemblies ([260](#)) using a stiff bristled nonmetallic brush.

WARNING: TO PREVENT INJURY WHEN USING COMPRESSED AIR, DIRECT STREAM AWAY FROM BODY. USE SAFETY GOGGLES TO PREVENT EYE INJURIES FROM FINE DUST PARTICLES.

- D. Disperse residual dust and particles from the battery with blasts of clean, dry, compressed air not over 1.38 bar (20 psi).
- E. Coat all cell nuts ([340](#)), ([120](#)), and intercell links ([140](#) through [180](#)) with a light film of [M02](#).

CAUTION: SILICONE COATINGS ARE NOT SUITABLE DUE TO THE ALKALINE ELECTROLYTE.

- F. Clean the exterior surfaces of the battery cover ([020](#)) and battery case ([010](#)) using a soft, clean cloth, moistened with water. Dry with compressed air or a dry, clean cloth.

24-32-21

4001
Jan 23/2023



COMPONENT MAINTENANCE MANUAL
539CH2

3. Thorough Cleaning

- A. The battery must be discharged (refer to [Initial discharge](#) and [Cell shorting](#)) and disassembled (refer [DISASSEMBLY](#)).
- B. Remove greasy residue from power connector ([090](#)) with warm mild soapy [M03](#) water.
- C. After ensuring that the ¼ turn vent valves ([350](#)) are closed, wash each cell ([260](#)) in running water. Do not allow any water to enter the cell. Dry with compressed air or a dry, clean cloth.
- D. Without submerging the connector of sensor harness ([190](#)), wipe clean with damp cloth and let dry.
- E. Wash the battery case ([010](#)), cover ([020](#)), cover insulator ([040](#)), spacers ([050](#)) & ([057](#)), thermostat plate ([060](#)), gasket ([130](#)), nuts ([257](#)), ([120](#)), ([340](#)) washers ([110](#)), ([330](#)), intercell links ([140](#) through [180](#)), and screws ([100](#)), ([250](#)) in warm mild soapy [M03](#) water to remove dirt and salt deposits. A plastic scraper or a stiff bristled brush (nonmetallic) may be used to aid in the removal of heavy deposits. Rinse away [M03](#), and thoroughly dry with compressed air or a dry, clean cloth.



COMPONENT MAINTENANCE MANUAL
539CH2

CHECK

1. General

This section contains battery inspection information. The procedures are written in step-by-step formats that follow the process flow outlined in [Figure 1001](#).

NOTE: All voltage readings are DC unless otherwise stated.

NOTE: All () part identification numbers herein are [IPL Figure 1](#) item numbers.

2. Initial New Battery Commissioning

A. Before the initial charge, thoroughly inspect the battery assembly to ensure no damage has occurred during shipping or storage as follows:

NOTE: For a new battery not receiving its initial commission within one year of its DOM, then battery must follow [Figure 1001](#)

- (1) Inspect the battery case ([010](#)) and cover ([020](#)) for dents, distortion, or other damage. If found, replace case ([010](#)) and cover ([020](#)).
- (2) Remove the battery cover ([020](#)), pad ([030](#)), and formed insulator ([040](#)).
- (3) Visually confirm the power connector ([090](#)) is present and undamaged.
- (4) Visually confirm all cells ([260](#)) are positioned for proper polarity per [Figure 7002](#).
- (5) Visually confirm all cells ([260](#)) are equipped with a ¼ turn vent valve ([350](#)).
- (6) Tighten all upper cell nuts ([340](#)) and connector nuts ([120](#)) per [Table 8001](#).
- (7) Visually confirm the sensor harness ([190](#)) is present and undamaged.

B. Charge the battery per [Charge](#) on page [1007](#) and level electrolyte per [Electrolyte leveling](#) on page [1008](#).

C. Do successful [Battery insulation](#) test and install battery cover ([020](#)), pad ([030](#)), and formed insulator ([040](#)), then the battery is ready for service.

3. Component Inspection

A. Cell ([260](#))

- (1) Visually check for evidence of electrolyte leakage, cracks, corrosion, burns, holes, or cross-threaded terminals. Replace any defect cells with new Saft cells ([260](#)).
- (2) Excessive salt around a terminal post indicates leakage. Refer to [Cell hardware replacement](#) in [REPAIR](#) for replacement of lower terminal O-ring ([270](#)) if leakage is evident.
- (3) Visually check each cell ¼ turn vent valve ([350](#)) for defective O-rings ([360](#)), cracks, or other physical damage. Replace defective O-rings ([360](#)).
 - (a) Suspect vent valves should be tested in accordance with [Vent valve tests](#) on page [1008](#) and/or be discarded, if necessary.
- (4) Inspect nuts ([320](#)) and washers ([280](#)), ([290](#)), and polarity washers ([300](#)), ([310](#)) to ensure it is free of bends, tarnish, corrosion, burns, or loss of plating. Minor tarnish can be polished off with a fine wire brush for metallic components and a dry cloth for polarity washers ([300](#)), ([310](#)). Replace as necessary with new Saft components.

24-32-21

5001
Jan 23/2023



COMPONENT MAINTENANCE MANUAL
539CH2

- B. Inspect the nuts ([120](#)), ([340](#)) and washers ([110](#)), ([330](#)) to ensure it is free of bends, tarnish, corrosion, burns, or loss of plating. Minor tarnish can be polished off with a fine wire brush. Defective hardware should be replaced.
- C. Intercell terminal links ([140](#) through [180](#))
Inspect for bends, tarnish, loss of nickel plating, corrosion, or burns. Tarnish can be polished off with a fine wire brush. Replace any defective intercell links.
- D. Spacers ([050](#)), ([057](#))
Inspect for contamination and free of cracks or holes. Replace any that are defective.
- E. Power connector ([090](#))

CAUTION: A DEFECTIVE POWER CONNECTOR CAN CAUSE DANGEROUS OVERHEATING AND IN-SERVICE LOW VOLTAGE DURING DISCHARGE.

- (1) Check the power connector ([090](#)) for evidence of arcing, corrosion, cracks, or cross threaded terminals.
 - (2) Using the same methods in [Battery insulation](#) check on page [1004](#), check the insulation between the positive pin and the connector shell and the negative pin and connector shell.
 - (3) Discard any connector that is found to have any damage or fails the insulation test and replace with new Saft battery power connector ([090](#)).
- F. Sensor harness ([190](#))
 - (1) Inspect electrical connector for bent or loose pins, corrosion, cracks, faulty wire connections, and evidence of arcing.
 - (2) Visually check all wiring damage to insulation, cracked or broken wire, and other physical defects
 - (3) Inspect charge control thermistor and thermostat for damage, loose or broken wire connections, cracks, dents, or other physical defects.
 - (4) Any evidence of the above conditions, however minor, is grounds for rejection. Discard the damaged unit and replace with factory new.

NOTE: Sensor harness ([190](#)) is a non-repairable item and should be replaced if defective.

- G. Battery cover ([020](#)), case ([010](#)), thermostat plate ([060](#))
Inspect the components for minor for damage. If found, replace with new Saft cover ([020](#)), case ([010](#)), or thermostat plate ([060](#)) as needed.



COMPONENT MAINTENANCE MANUAL
539CH2

REPAIR

1. General

This section contains basic battery component procedures for removing and replacing components.

NOTE: The () part identification numbers herein are [IPL Figure 1](#) item numbers.

NOTE: All voltage readings are DC unless otherwise stated.

2. Required Test Equipment

NOTE: Test equipment with equivalent specifications can be used.

Refer to [Special Tools, Fixtures, Equipment, and Consumables](#) for listing of Standard Tools.

3. Component Replacement

A. Cell replacement

A battery containing cell(s) ([260](#)) require replacement. Note the [All cell replacement](#) recommendation below.

(1) All cell replacement

(a) For a battery compliant with the following, it is best to assume that all the original cells are or soon will be in unsatisfactory condition. Saft strongly recommends all cells ([260](#)) should be replaced with new Saft cells for a battery having:

1 3 or more defective cells are replaced during the same maintenance interval.

Or

2 1 or more cells are found to be faulty during this maintenance period and 5 of the original cells in the battery have been previously replaced due to faults.

NOTE: The recommendation does not apply to the following failures: terminal thread damage, cell leakage, or cell short-circuit.

(2) Do [DISASSEMBLY](#) and [ASSEMBLY](#) to replace cells.

B. Cell hardware replacement

WARNING: USE CARE NOT TO TILT CELLS WHILE LOWER HARDWARE ARE LOOSENED OR REMOVED; CONTACT OF ELECTROLYTE WITH CAN CAUSE SEVERE BURNS.

NOTE: The battery should be discharged prior to starting cell hardware replacement.

(1) Replace necessary cell hardware ([280](#)), ([290](#)), ([300](#)) or ([310](#)), ([320](#)) by removing and replacing the nuts ([120](#)), ([340](#)), washers ([110](#)), ([330](#)), and links ([140](#) to [180](#)). Torque nuts ([120](#)), ([320](#)), ([340](#)) per [Table 8001](#) as required.

24-32-21

6001

Jan 23/2023



COMPONENT MAINTENANCE MANUAL
539CH2

C. Terminal O-ring (270) replacement

- (1) Remove the necessary nuts (120), (340), washers (330), (110), and links (140 to 180).

WARNING: USE CARE NOT TO TILT CELLS WHILE LOWER HARDWARE ARE LOOSENED OR REMOVED; CONTACT OF ELECTROLYTE WITH CAN CAUSE SEVERE BURNS.

- (2) Remove lower terminal nut (320), the polarity washer (300) or (310), the washers (280), (290) and terminal O-ring (270) being careful to prevent anything from falling into the cell opening.
- (3) Replace O-ring (270), install washer (280), 2 belleville washers (290), polarity washer (300) or (310). Torque lower terminal nut (320) per Table 8001.

NOTE: Spring washers (290) should be put in parallel, stacked in same direction with the larger edge downward on the terminal.

- (4) Install the necessary links (140 to 180), washers (330), (110), and nuts (120), (340). Torque nuts (120), (340) per Table 8001 as required.



COMPONENT MAINTENANCE MANUAL
539CH2

ASSEMBLY

1. General

This section contains assembly instructions necessary after disassembly.

NOTE: Make sure all components are clean and dry before re-assembly.

NOTE: All () part identification numbers herein are [IPL Figure 1](#) item numbers.

2. Sensor harness (190)

- A. Insert the sensor harness (190) connector into its mounting hole on the case (010) and reinstall the connector mounting screws (250) and nuts (257) by torquing per [Table 8001](#).
- B. Insert the thermostat liner (057) and thermostat liner assembly on the inside face of the center partition, taking care to align the holes in the liner with the hole in the partition.
- C. Insert the thermostat plate (060) in back of spacer assembly so that the spacer assembly is between the thermostat plate (060) and the thermostat liner (057), which is against the partition.
- D. Pass the thermostat-end of sensor harness (190) through the hole in the partition, liner, and spacer assembly.
- E. Attach the thermostat to the thermostat plate (060) with thermostat mounting nuts (257). Torque per [Table 8001](#).

3. Spacers (050) and Cells (260)

Install spacers (050), sensor harness (190), and cell assemblies (260) into the battery case (010), using the following steps. Refer to [Figure 7001](#) and [Figure 7002](#).

- A. Insert one edge of bottom spacer into battery case (010) from the left or right side, then slide the spacer under the cell partition.
HINT: It is often easier to install the center cell of a row last.
- B. Install the left and right side row of cells and spacers in accordance with the following steps and as shown in [Figure 7001](#) and [Figure 7002](#).
 - (1) Install spacers (050) into the battery case (010) as shown in [Figure 7001](#).
NOTE: Spacers are used as required to ensure the left and right hand row of cells are retained securely in place to prevent free movement of the cells. The maximum quantity to be used is shown in [Figure 7001](#).
 - (2) Install seven cell assemblies (260) in the left and right side of the battery case, be sure to maintain the proper cell arrangement and polarity orientation (see [Figure 7002](#)). Insertion of the last cell on each side is sometimes difficult and can be assisted by pushing down on the terminals with a small block of soft wood.
- C. Install the center row spacers and cells in accordance with the following steps and as shown in [Figure 7001](#) and [Figure 7002](#).
 - (1) Install spacers (050) into the battery case (010) as shown in [Figure 7001](#).

COMPONENT MAINTENANCE MANUAL 539CH2

NOTE: Spacers (050) are used as required to ensure the center row cells are retained securely in place to prevent free movement of the cells. As indicated in Figure 7001, the maximum quantity to be used is as shown.

- (2) Install six cell subassemblies (260) in the center partition of battery case (010). Be sure to maintain the proper cell arrangement and polarity orientation, see Figure 7002. Install the charge control thermistor plate between cells 6 and 9, as shown in Figure 7002. Insertion of the last cell in a row is sometimes difficult and can be assisted by pushing down on the terminals with a small block of soft wood.
- D. Apply a small amount of M02 to the threads of the cell terminals.
 - E. Torque the lower terminals nuts (320) of the cell assemblies (260) per Table 8001.

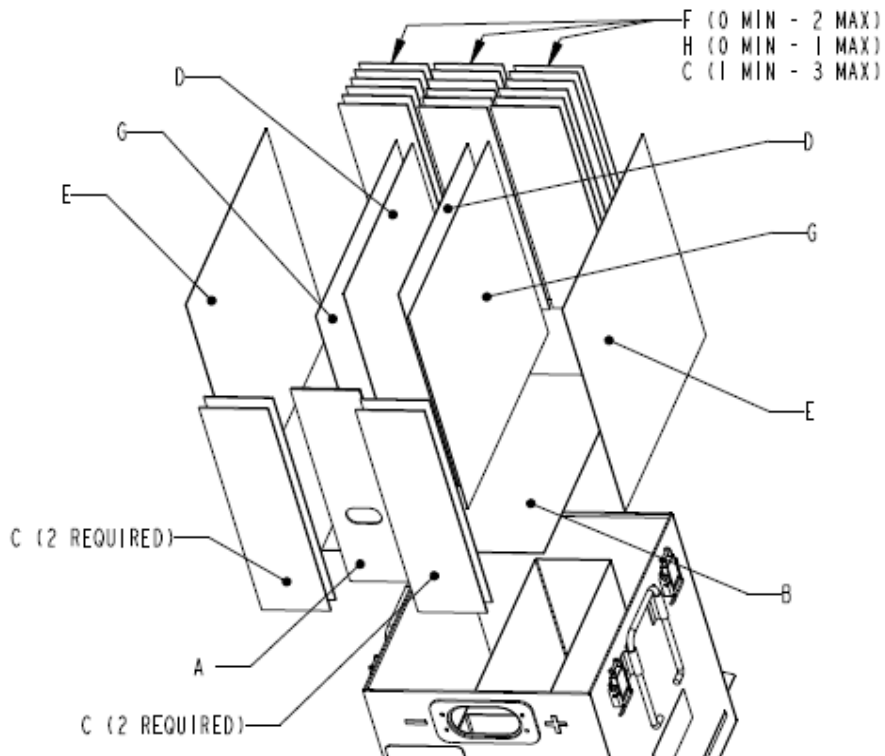

ITEM	DESCRIPTION	DIMENSION [IN]	MAX. UNIT PER ASSEMBLY
A or (057)	Spacer, Thermostat	9.86 x 2.95	1
B	SPACER	9.52 x 10.72 x 0.032	1
C	SPACER	2.953 x 10.373 x 0.062	13
D	SPACER	9.108 x 9.861 x 0.032	2
E	SPACER	10.629 x 10.373 x 0.032	2
F	SPACER	2.953 x 10.373 x 0.032	6
G	SPACER	10.629 x 9.861 x 0.020	2
H	SPACER	2.953 x 10.373 x 0.020	3

Cell and Spacer Installation
Figure 7001

COMPONENT MAINTENANCE MANUAL 539CH2

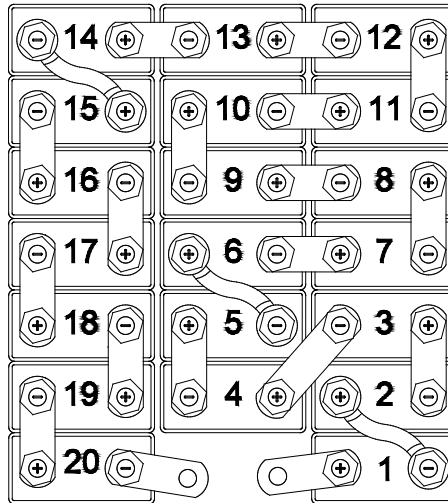

Cell Number and Polarity Orientation
Figure 7002

4. Power connector (090)
 - A. Assemble power connector gasket (130) to power connector (090).
 - B. Insert terminals of power connector (090) through the oval mounting hole in the front of the battery case (010).
 - C. Attach the power connector (090) to the battery case (010) with screws (100). Secure the power connector (090) by torquing the screws (100) per [Table 8001](#).
5. Complete Battery
 - A. Install intercell terminal links (140 through 180) on the terminals of the cell sub-assemblies (260) and power connector (090) as shown in [Figure 7002](#).
 - B. Install the two wire lead/lug assemblies of the sensor harness (190) on the terminal posts of the cell sub-assemblies (260) as shown in [Figure 7001](#).
 - C. Lightly lube with [M02](#) cell terminals, nuts, links, and connector contacts using a nonmetallic brush.

CAUTION: DO NOT CRIMP WIRE OF THE SENSOR HARNESS.
 - D. Install nuts (340), (120) and washers (330), (110) onto the terminals of the cell assemblies (260) and terminals of the power connector (090). Torque nuts (340), (120) per [Table 8001](#).
 - E. Lightly lube with [M02](#) any other components that might be susceptible to atmospheric corrosion
 - F. Install formed insulator (040) on top of the cells as shown in [IPL Figure 1](#).
 - G. Install the hold down pad (030) onto the cell assemblies, being sure that each vent hole mates properly with the cell assembly vent valve.
 - H. Install the battery cover (020) onto the battery case (010) and secure in place by fastening the latches.



COMPONENT MAINTENANCE MANUAL
539CH2

PAGE INTENTIONALLY LEFT BLANK

24-32-21

7004
May 4/2022



COMPONENT MAINTENANCE MANUAL
539CH2

FITS AND CLEARANCES

1. Torque Table

IPL FIGURE	ITEM NUMBER	TORQUE VALUE		NAME, LOCATION
		Nm	lb _f -in	
1	340 , 120	13.0 ± 1.0	115 ± 9	Nut, Terminal, Upper
1	320	5.0 ± 0.5	44 ± 4	Nut, Terminal, Lower
1	250	0.8 ± 0.1	7 ± 1	Screw, Connector Mounting
1	100	2.3 ± 0.2	20 ± 2	Screw, Sems
1	257	0.8 ± 0.1	7 ± 1	Nut Aux. Connector Mounting

Torque Values
Table 8001

2. Fits and Clearances Table

No fits and clearances required.



COMPONENT MAINTENANCE MANUAL
539CH2

PAGE INTENTIONALLY LEFT BLANK

24-32-21

8002
May 4/2022



COMPONENT MAINTENANCE MANUAL
539CH2

SPECIAL TOOLS, FIXTURES, EQUIPMENT, AND CONSUMABLES

1. Special Tools

A. Battery maintenance kit

NOTE: Equivalent tools can be used.

NOTE: A special tool kit (P/N 416161) is available from Saft containing special tools T01, T02, T03, and T04. The tools are housed in a polypropylene box.

- (1) T02 (P/N 416232) is assembled using syringe P/N 105112 and nozzle P/N 104184 or T02 (P/N 020916-001) is assembled using syringe P/N 018327-000 and nozzle P/N 020914-001.

ITEM	DESCRIPTION	09052 P/N	F6177 P/N
T01	Universal vent wrench	093365-000	413876
T02	Syringe assembly (with nozzle 20 mm (0.79 in))	020916-001	416232
T03	1.2Ω 3 W equalizing resistors	-	164829
T04	Universal cell extraction tool	-	416159
	M10x1.25 tool	017556-000	-
T05	Vent Valve adapter for MS valves	024398-000	-

Special Tools
Table 9001

2. Standard Tools

A. The following items are recommended to do the procedures described in this manual. When necessary equivalent substitutes may be used.

- Constant current charger (DC current range 0 – 60A, minimum open DC voltage 40V)
- Constant current load bank (DC current range 0 – 60 A, DC voltage range 1 – 40V)
- Megohmmeter (0 – 50 MΩ @ 250 V DC continuous)
- Precision Multimeter (Volt, Ω, mA) 2000 count, accuracy 1% or better
- Torque Wrench (Insulated) 0 to 15 N-m (0 to 133 lb_f-in)
- Torque Screwdriver 0 to 3.4 N-m (0 to 30 lb_f-in)
- Thermometer, Immersion
- Standard mechanic's tools.
- Safety gloves.
- Protective goggles.
- Safety shoes.
- Eye wash.
- Protective apron.
- Stiff bristle brush (non-metallic)
- Small paintbrush (non-metallic)
- Dry, compressed air source [less than 1.38 bar (20 psi)]
- Soft, clean cloth (at least two required)

24-32-21

9001
Jan 23/2023



COMPONENT MAINTENANCE MANUAL
539CH2

3. Consumables

This paragraph describes the consumables used in the CMM.

NOTE: Equivalent alternatives can be used for list items.

ITEM	DESIGNATION PART NUMBER AND SPECIFICATION DESCRIPTION	MANUFACTURER OR SUPPLIER (NAME, ADDRESS, CODE)
M01	Distilled or deionized water @ +20°C ± 5°C (+68°F ± 9°F): Clear, colorless, and odorless while boiling Conductivity < 33 µS/cm 5 < pH < 7 Mn-COD < 30 mg/l (1.7 x 10 ⁻⁵ oz/in ³) (Chemical Oxygen Demand, methodology to evaluate organic or mineral pollution) Chlorines Cl ⁻ < 5 mg/l (2.9 x 10 ⁻⁶ oz/in ³) Sulfates SO ₄ ²⁻ < 10 mg/l (5.8 x 10 ⁻⁶ oz/in ³) STORAGE: dry and clean container without any corrosion and damage; Temperature: +20°C ± 5°C (+68°F ± 9°F). Over 1 year of storage, do an analysis of the liquid.	Local Vendor
M02	Neutral petroleum jelly Density @ +60°C (+140°F) Range = 0.840 to 0.866 kg/l (0.486 to 0.501 oz/in ³) Melting Point Range = +46°C to +52°C (+115°F to +126°F) Acidity/Alkalinity = Neutral to Litmus	Mineral Vaseline NATO: S 743 F: AIR 3565 US: VV-P-236A UK: DEF 2333
M03	Mild soap	Local Vendor

Consumables
Table 9002

24-32-21

9002
May 4/2022



COMPONENT MAINTENANCE MANUAL
539CH2

ILLUSTRATED PARTS LIST

1. Introduction

A. Purpose

- (1) This section provides illustrations and parts breakdown of the 539CH2 batteries, which can be disassembled, replaced, and reassembled.

B. Explanation and usage of section

(1) Assembly order indenture system

The Indenture System used in the parts list shows the relationship of one part to another. For a given item, the number of indentures depicts the relationship of the item to the associated next higher assembly.

(2) Effectively code

Reference letters (A, B, C, etc.) are assigned in the EFF CODE column to each top assembly. The reference letter of the applicable top assembly is also shown in the EFF CODE column for each detail part and subassembly except that no reference letter is shown for detail parts and subassemblies used on all top assemblies.

(3) Quantity per assembly

The UNITS PER ASSY column shows the total number of units required per assembly, per subassembly, and per sub-subassembly as applicable. The letters REF indicates the item is listed for reference purposes.

(4) Parts replacement data

Interchangeability information will be provided in a future manual revision if it becomes applicable.

(5) Service Bulletin incorporation

Service Bulletin incorporation information applicable to the parts list will be provided in a future manual revision if it becomes applicable.

(6) Items not illustrated

Items not illustrated are indicated by a dash (-) ahead of the item numbers in the Figure and Index column.

(7) Alpha variant item numbers

- (a) Alpha variants A - Z (except I and O) are assigned to existing item numbers when necessary to show:

- 1 Added items
- 2 Service Bulletin modifications
- 3 Configuration differences
- 4 Optional parts
- 5 Product improvement parts (non-service bulletin)

- (b) Alpha variant item numbers are not shown on the exploded view when the appearance and location of the alpha variant item is the same as the basic item.

24-32-21

10001
May 19/2021



COMPONENT MAINTENANCE MANUAL
539CH2

(8) Vendors

The vendor of all parts shown in the parts list is as follows:

CAGE Code	NAME / ADDRESS	CAGE Code	NAME / ADDRESS
09052	Saft America Inc. 711 Gil Harbin Industrial Boulevard Valdosta, GA 31601 USA Phone: +1 (229) 247-2331 Fax: +1 (229) 247-8486	F6177	Saft 126 quai Charles Pasqua 92300 Levallois-Perret France Phone: +33 1 58 63 16 00 Fax: +33 1 58 63 16 18

<http://www.saftbatteries.com>

24-32-21

10002
Jan 23/2023



COMPONENT MAINTENANCE MANUAL
539CH2

2. Numeric Index

PART NUMBER	AIRLINE STOCK NUMBER	FIGURE NUMBER	ITEM NUMBER	UNIT	UNITS PER ASSY
MS21083C04 (09052 090064-000)			257	EA	6
009384-000			130	EA	1
012536-002			360	EA	20
015575-000			140	EA	5
015579-000			120, 320, 340	EA	82
018552-003			020	EA	1
018559-000			040	EA	1
018567-000			160	EA	10
018568-000			170	EA	1
018569-000			180	EA	3
018733-000			057	EA	1
018737-000			060	EA	1
018740-000			190	EA	1
018951-000			050	EA	1
021870-000			280	EA	40
021871-000			290	EA	80
022078-000			090	EA	1
022228-000			110, 330	EA	42
023388-002			310	EA	20
023388-001			300	EA	20
023619-000			350	EA	20
024142-000			030	EA	1
024190-000			010	EA	1
024257-000			260	EA	20
025902-000			010A	EA	1
025920-000			1A		RF
025962-000		1	1		RF
026705-000 REPLS 015577-000			150	EA	2
091181-002			270	EA	40
092178-008			250	EA	4
093616-000			100	EA	4

24-32-21

10003
Jan 23/2023

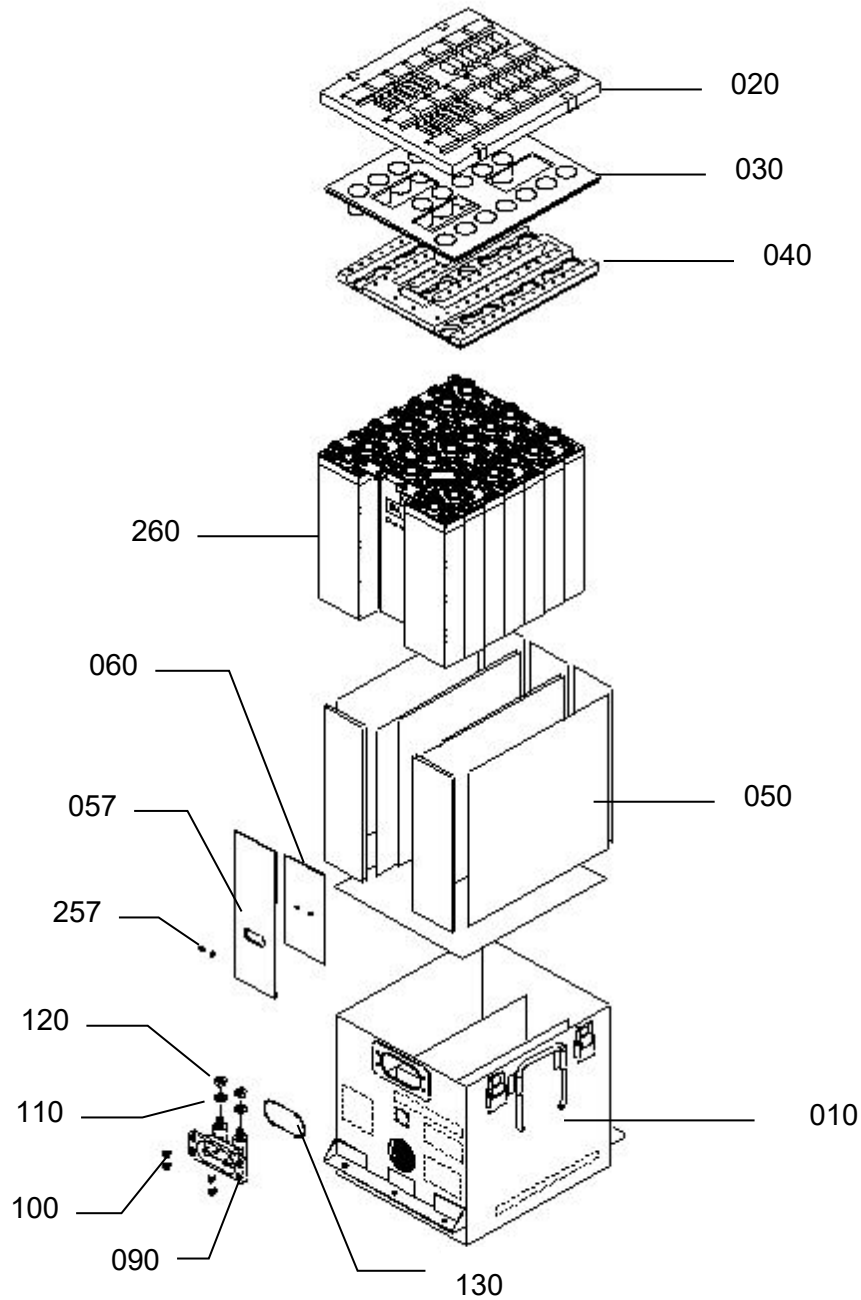

Battery, Exploded View
IPL Figure 1 (#1 of 4)

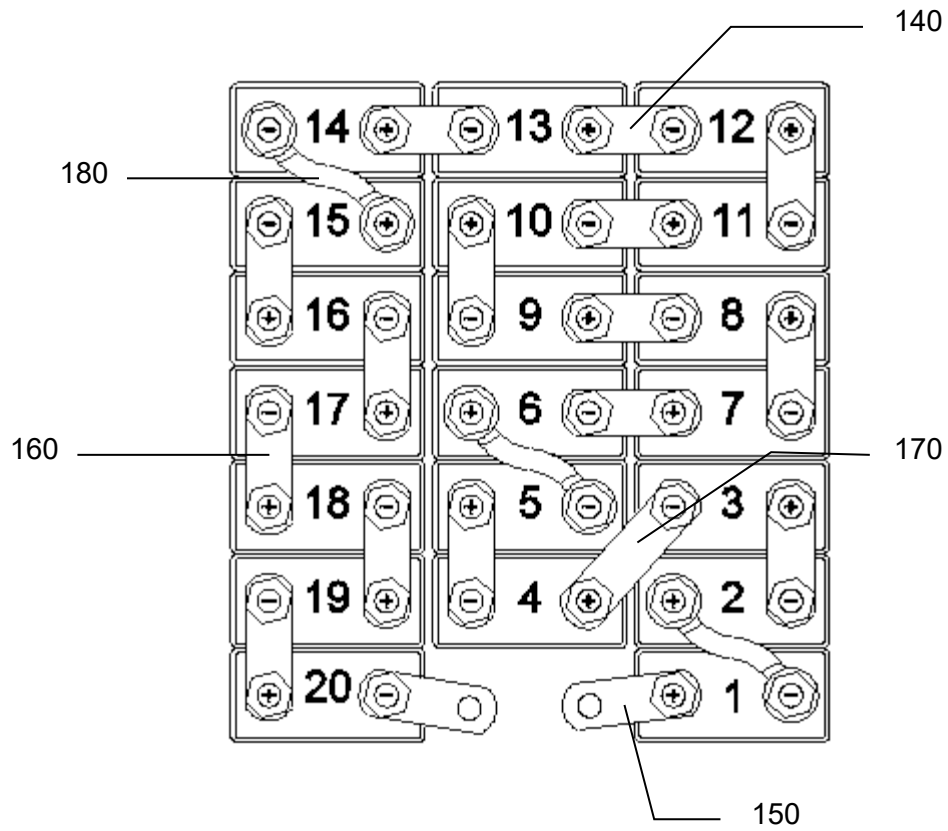

Battery, Exploded View
IPL Figure 1 (#2 of 4)



COMPONENT MAINTENANCE MANUAL
539CH2

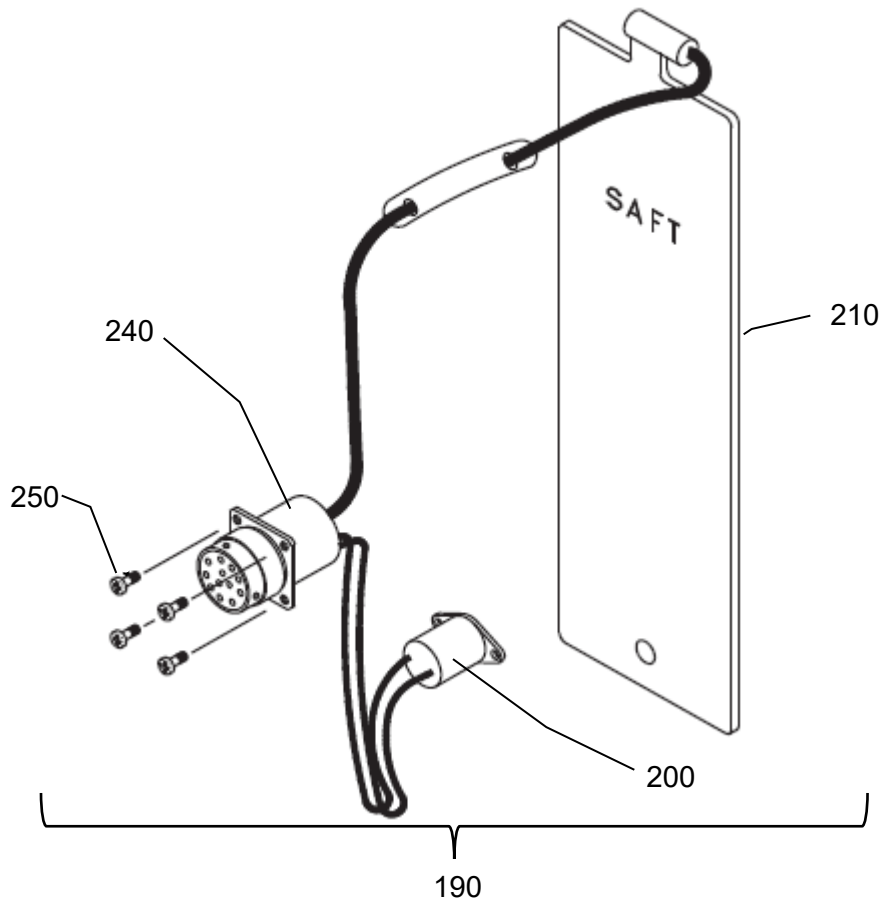

Battery, Exploded View
IPL Figure 1 (#3 of 4)

24-32-21

10006
Jan 23/2023

COMPONENT MAINTENANCE MANUAL 539CH2

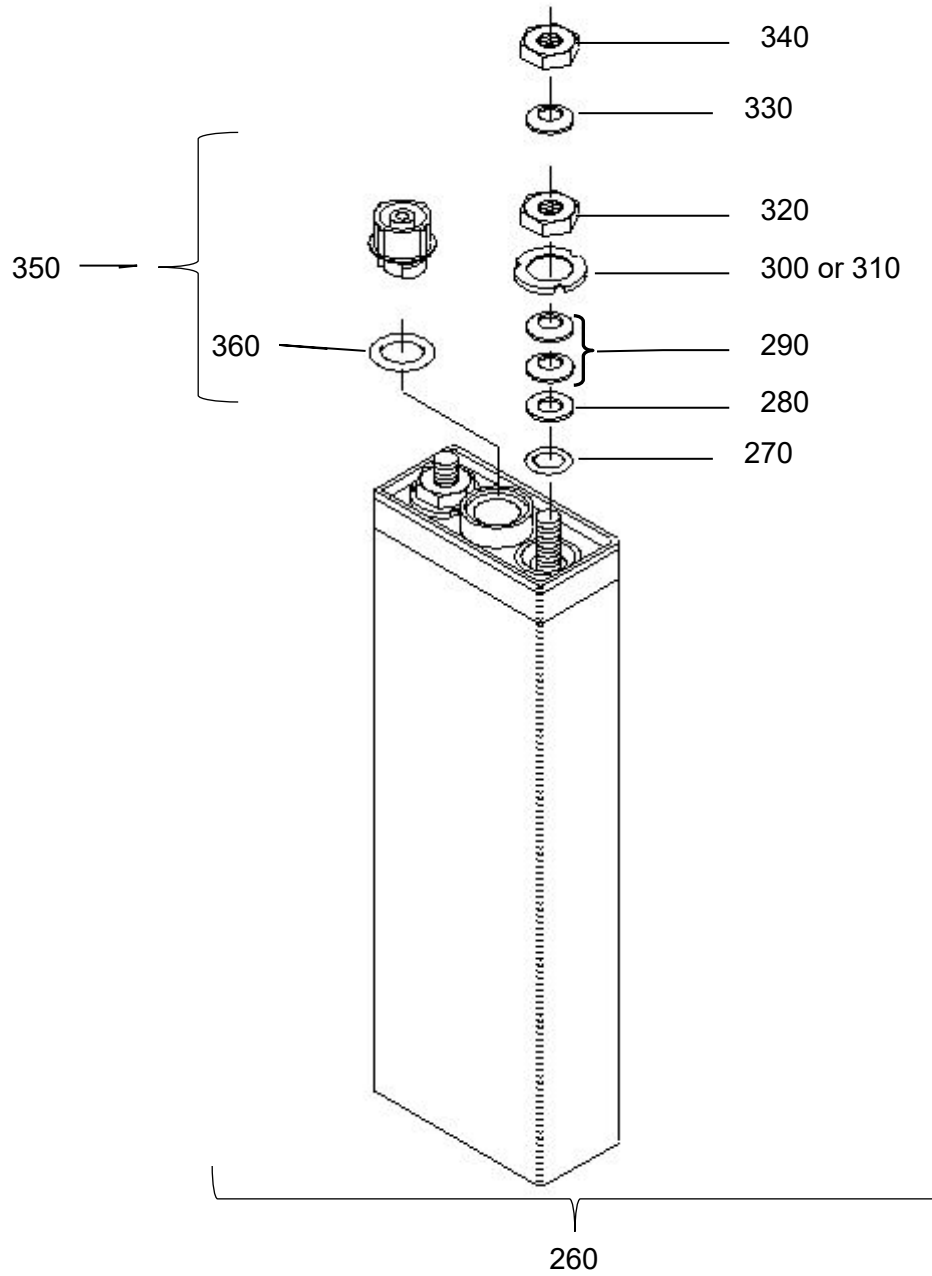

Battery, Exploded View
IPL Figure 1 (#4 of 4)



COMPONENT MAINTENANCE MANUAL
539CH2

3. Detail Parts List

FIGURE & ITEM NUMBER	PART NUMBER	AIRLINE PART NO.	NOMENCLATURE 1234567	EFF CODE	UNITS PER ASSY
1 - 1	025962-000		Battery, 539CH2		RF
010	025963-000		. Case, Marked		1
020	018552-003		. Cover		1
030	024142-000		. Pad, Hold Down		1
040	018559-000		. Insulator, Formed Top		1
050	018951-000		. Kit, Spacer		1
057	018733-000		. . Spacer, Thermostat		1
060	018737-000		. Plate, Thermostat		1
090	022078-000		. Connector, Power		1
100	093616-000		Attaching Parts . Screw, Sems * * *		4
110	022228-000		. Washer, Belleville		2
120	015579-000		. Nut, Connector		2
130	009384-000		. Gasket, Connector		1
140	015575-000		. Link, Intercell - 0.125 X 0.750 X 1.334		5
150	015577-000		. Link, Intercell - 0.125 X 0.750 X 1.516 REPLD BY ITEM 150A		2
-150A	026705-000		. Link, Intercell - 0.125 X 0.750 X 1.516 REPLS ITEM 150		2
160	018567-000		. Link, Intercell - 0.125 X 0.750 X 1.476		10
170	018568-000		. Link, Intercell - 0.125 X 0.750 X 2.023		1
180	018569-000		. Link, Intercell - 0.118 X 0.668 X 2.331		3
190	018740-000		. Harness, Sensor		1
200	NONPROC1		. . Thermostat, Temperature Sensing (NONPROCURABLE)		1
210	NONPROC2		. . Thermistor/Plate Assy (NONPROCURABLE)		1
240	NONPROC3		. . Connector, Sensor Harness (NONPROCURABLE)		1
250	092178-008		Attaching parts . Screw, Connector		4
257	MS21083C04		. Nut, Connector Mounting (09052 P/N 090064-000) * * *		6
260	024257-000		. Cell, CVH531KA (with hardware)		20
270	091181-002		. . O-Ring		2
280	021870-000		. . Washer, Flat		2
290	021871-000		. . Washer, Belleville		4
300	023388-001		. . Washer, Polarity, Red (+)		1
310	023388-002		. . Washer, Polarity, Blue (-)		1
320	015579-000		. . Nut, Lower		2

DASH (-) ITEM NOT ILLUSTRATED

24-32-21

10008
Jan 23/2023



COMPONENT MAINTENANCE MANUAL
539CH2

FIGURE & ITEM NUMBER	PART NUMBER	AIRLINE PART NO.	NOMENCLATURE 1234567	EFF CODE	UNITS PER ASSY
330	022228-000		. . Washer, Belleville		2
340	015579-000		. . Nut, Upper		2
350	023619-000		. . Valve, Vent		1
360	012536-002		. . . O-Ring		1

DASH (-) ITEM NOT ILLUSTRATED

24-32-21

10009
Jan 23/2023



COMPONENT MAINTENANCE MANUAL
539CH2

PAGE INTENTIONALLY LEFT BLANK

24-32-21

10010
Jan 23/2023



COMPONENT MAINTENANCE MANUAL
539CH2

STORAGE (INCLUDING TRANSPORTATION)

1. Introduction

- A. Storage preparation and packaging makes sure that the equipment is protected against any attack by atmospheric agents.
- B. For a battery which has been cleaned and serviced and is not directly put into service on board an aircraft, different methods can be recommended depending on the purpose and the environment conditions of the "storage".
- C. Keep the batteries and spares in a dry and clean room.

2. Inactive Long-Term Storage

A. Procedure

(1) The following must be done to any battery with prior service history.

- (a) [Charge](#), [Electrolyte level](#), [Vent valve test](#), and [Capacity test](#).

NOTE: It is not necessary that it be short circuited. There is no need of maintenance operation during the storage period.

NOTE: The standard cardboard packaging is considered unsealed and allows 2 years of storage. Storage is allowed for 10 years if the following conditions are met: sealed packaging and isolated from harmful agents (i.e.: dirt, dust, vibrations, or corrosive atmosphere).

- sealed packaging,
- temperature: +5°C to +35°C (+41°F to +95°F),
- humidity < 90%,
- normal vertical position,
- Isolated from detrimental agents: i.e., dirt, dust, dampness, vibration, corrosive atmosphere.

(2) Saft Ni-Cd batteries may be stored in temperatures ranging from -55°C to +5°C or +35°C to +60°C (-67°F to +41°F or +95°F to +140°F) for an accumulated exposure that does not exceed 30 days.

(3) Lead batteries must not be stored in the same room.

B. Servicing at end of long-term storage

STORAGE TIME	SERVICE PROCEDURE
Less than or equal to 12 months	Do Visual Inspection , and return to Figure 1001 entry point " C "
More than 12 months	Do Charge and return to Figure 1001 entry point " Received "

Return to Service Following Storage
Table 15001

3. Inactive Standby Storage

The battery is charged after being serviced then stored fully charged in a dedicated room in such a way that it can be installed in the aircraft without further maintenance except as provided within this section. Refer to [Figure 15002](#).

NOTE: At any time during the inactive standby storage shown in [Figure 15002](#), the battery may be installed on the aircraft or placed into [Inactive Long-Term Storage](#).

NOTE: For a battery previously stored at a temperature below ambient temperature, condensation within the battery may occur, do [Battery insulation](#) before installation.

A. Standby period is the rest time that corresponds to 80% available capacity shown in [Figure 15001](#), example, 24 days at +30°C (+86°F).

NOTE: The maximum time for the standby period is 90 days for temperatures ≤ +23°C (+73°F).

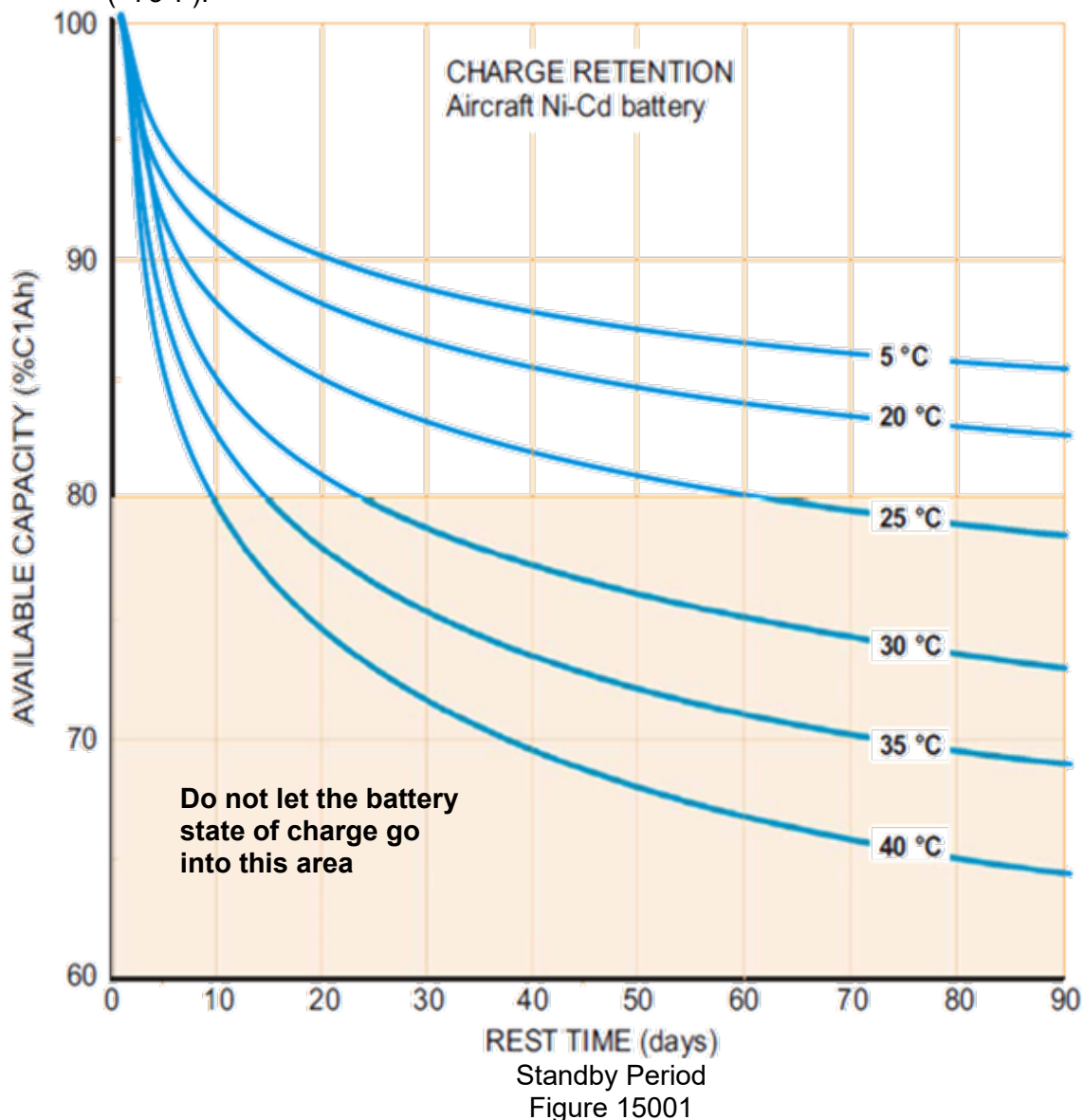



COMPONENT MAINTENANCE MANUAL
539CH2

B. Refresh charge is a quick constant current charge that can be done at the end of a [Standby period](#) to extend the time the battery is in inactive standby storage. The charge is given in the [Table 15002](#).

CAUTION: DO NOT DO THE 4 HOURS FINAL CHARGE AT 0.1 C₁A (REFER TO [CHARGE](#)) DURING THIS 'REFRESH' CHARGE OPERATION.

CHARGE RATE	VOLTAGE (END OF "REFRESH" CHARGE)
0.1C ₁ A	30.0V for 20 Cells
0.5C ₁ A	31.0V for 20 Cells
1.0C ₁ A	31.4V for 20 Cells

Refresh Charge
Table 15002

- C. Standby duration consists of a maximum of 3 standby periods with 2 refresh charges. The number of consecutive standby durations is limited to 3. Refer to [Figure 15002](#).
- (1) For a battery completing the first or second standby duration and not immediately installed in the aircraft or sent into long-term storage, do the one of the following:
 - (a) For environments ≤ +30°C (+86°F) do [Battery insulation](#), [Initial discharge](#), [Charge](#), [Electrolyte level](#), and [Battery insulation](#).
 - (b) For environments > +30°C (+86°F) do [Battery insulation](#), [Initial discharge](#), [Cell shorting](#), [Charge](#), [Electrolyte level](#), and [Battery insulation](#).
 - (2) For a battery completing the third consecutive standby durations, the battery can go into [Inactive Long-Term Storage](#) or return to [Figure 1001](#).
- D. Inactive standby storage schedule is limited to the [Standby duration](#) being conducted a maximum of 3 times as shown in [Figure 15002](#).

NOTE: At any time during this inactive standby storage schedule shown in [Figure 15002](#), the battery may be installed on the aircraft or placed into [Inactive Long-Term Storage](#).

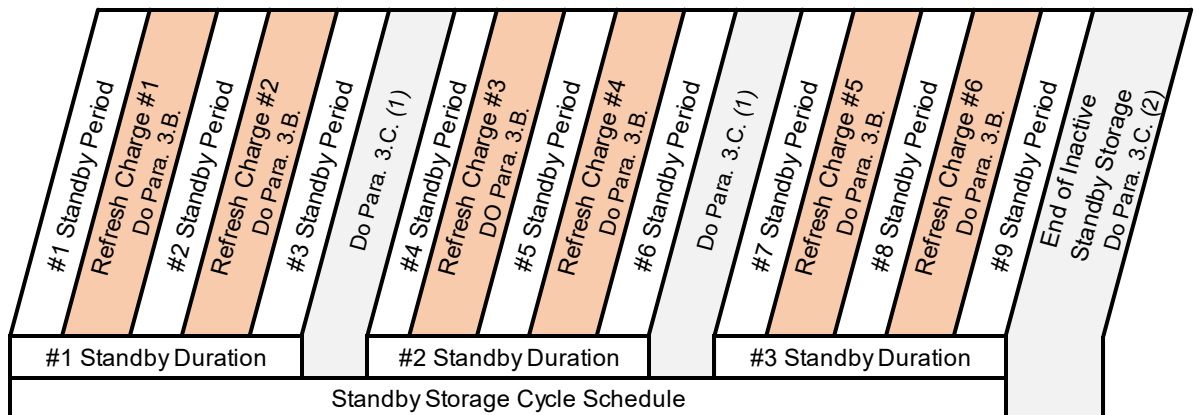

Inactive Standby Storage Schedule
Figure 15002



COMPONENT MAINTENANCE MANUAL
539CH2

4. Active Standby Mode (Trickle Charge)

CAUTION: WATER CONSUMPTION OCCURS WHEN THE BATTERY IS CONTINUOUSLY CHARGED, IN AN OVERCHARGE CONDITION. SAFT DOES NOT RECOMMEND THIS METHOD, HOWEVER SOME OPERATORS TAKE RESPONSIBILITY FOR ITS USE.

NOTE: This method is not reliable due to quantity and inaccuracy of water consumption.

Example: A 40 Ah battery on a continuous trickle charge of 3 mA/Ah for one month may consume over 35 cm³/cell (2.14 in³/cell) of water.

5. Storage of spare parts

A. Spare Cells

Spare cells must be stored in a vertical upright position, filled, and discharged condition (electrolyte levels are not visible in discharged cells). It is not necessary to short circuit the cells. The vent valves must be installed. The storage conditions are the same as those given in paragraph Inactive long-term storage. No maintenance operation is needed during storage. Before installation in a battery, cells must be visually inspected for damage or leakage and repaired as necessary in accordance with this CMM.

B. Spare O-rings, gaskets, and vent valves

(1) O-rings and gaskets

Six (6) years of storage period starts from the date of manufacture unless otherwise specified on the packaging. The O-rings and gaskets should be protected from exposure to the air, light, and high humidity < 85%. Storage life depends on temperature. It is recommended to store the parts in a cool area < +25°C (+77°F). Above +35°C (+95°F), storage life is reduced to 5 years. Before use the O-rings or gaskets it must be inspected. In case of visible signs of damage, distortion, or deterioration, the part must be discarded.

O-rings must be inspected before use and must be disregarded if there are visible signs of damage, distortion, or deterioration.

(2) Vent valves with O-rings

Six (6) years of storage period starts from the date of manufacture unless otherwise specified on the packaging. The vent valves and O-rings should be protected from exposure of air, light and high humidity (< 85%). Storage life depends on temperature. It is recommended to store the parts in a sealed container (non-PVC) in a cool area < +25°C (+77°F). Above +35°C (+95°F), storage life is reduced to 5 years. Before use the vent valves and O-rings it must be inspected. In case of visible signs of damage, deformation, or deterioration, the vent valve and O-ring must be discarded.

C. Other spares

Other spares, protected from external contamination (i.e. dirt, dust, dampness, vibration, corrosive atmosphere) and high humidity (> 85%), may be stored for unlimited periods. Before use, they must be inspected and any showing visible signs of damage, distortion or deterioration must be discarded.



COMPONENT MAINTENANCE MANUAL
539CH2

6. Transportation procedure

The battery is normally discharged before packing. If it is necessary to transport a charged battery, make sure that the output terminals are protected against short circuit.

The battery should then be packed vertically in its original container. If the original container is not available, the international and/or local packaging regulations applicable to the mode of transport and destination must be followed.

According to the IATA / IMDG dangerous goods regulations, Saft ships all existing nickel cadmium batteries or cells for aircraft under the classification UN2795 (wet, filled with alkali).

24-32-21

15005
Jan 23/2023



COMPONENT MAINTENANCE MANUAL
539CH2

PAGE INTENTIONALLY LEFT BLANK

24-32-21

15006
Jan 23/2023