



**To:** HOLDERS OF COMPONENT MAINTENANCE MANUAL 24-30-11, 43B050KB01 and 43B050KB02

**Subject:** CMM Revision No. 6 Dated May 23/2023

Replace revised pages by adding and removing pages for pages dated May 23/2023.

**NOTE:** The CMM can be downloaded from the internet at [www.saft.com](http://www.saft.com)

### **HIGHLIGHTS**

<b>CHAPTER/SECTION PAGE NUMBER</b>	<b>DESCRIPTION OF CHANGE</b>
Title Page T-1	Add Revision 5 with Date and removed confusing wording, updated website
Record of Revisions ROR 1	Add revision 5
List of Effective Pages LEP 1	Corrected/Changed pages
Service Bulletin List SBL 1	Update SB
Testing and Isolation 1002	Corrected Chart

**24-30-11**

Highlights Page 1 of 2

May 23/2023



PAGE OF INTENTIONALLY LEFT BLANK

**24-30-11**

Highlights Page 2 of 2  
May 23/2023



ECCN: EAR99  
CAGE Code 09052  
711 GIL HARBIN INDUSTRIAL BOULEVARD  
VALDOSTA, GEORGIA 31601  
Phone: +1 (229) 247-2331 Fax: +1 (229) 247-8486

# **COMPONENT MAINTENANCE MANUAL**

## **WITH**

## **ILLUSTRATED PARTS LIST**

### **Nickel Cadmium Aircraft Battery**

**43B050KB01**  
SAFT P/N 021931-000

**43B050KB02**  
SAFT P/N 024051-000

Website: [www.saft.com](http://www.saft.com)

**24-30-11**

T-1  
Rev 6 May 23/2023



COMPONENT MAINTENANCE MANUAL  
43B050KB01 / 43B050KB02

This document and all information contained herein are the property of Saft. Its use is restricted solely to the maintenance of Saft batteries and may under no circumstances be used for any other manufacturer's products. No person may, in whole or in part, duplicate, use or disclose this information for any other purpose without the prior written consent of Saft.

**24-30-11**

T- 2  
May 3/2021



COMPONENT MAINTENANCE MANUAL  
43B050KB01 / 43B050KB02

**RECORD OF REVISIONS**

REV NO.	ISSUE DATE	INSERT DATE	BY	REV NO.	ISSUE DATE	INSERT DATE	BY
1	03/31/97	03/31/97	Soft				
2	May 3/2021	May 3/2021	Soft				
3	Mar 25/2022	Mar 25/2022	Soft				
4	Nov 14/2022	Nov 14/2022	Soft				
5	May 15/2023	May 15/2023	Soft				
6	May 23/2023	May 23/2023	Soft				



COMPONENT MAINTENANCE MANUAL  
43B050KB01 / 43B050KB02

PAGE INTENTIONALLY LEFT BLANK

**24-30-11**

ROR 2  
Mar 25/2022



COMPONENT MAINTENANCE MANUAL  
43B050KB01 / 43B050KB02

**RECORD OF TEMPORARY REVISIONS**

TEMPORARY REV NO	ISSUE DATE	INSERTED DATE / INSERTED BY	DATE REMOVED / REMOVED BY	DATE INCORPORATED



COMPONENT MAINTENANCE MANUAL  
43B050KB01 / 43B050KB02

PAGE INTENTIONALLY LEFT BLANK

**24-30-11**

ROR 2  
Mar 25/2022





COMPONENT MAINTENANCE MANUAL  
43050KB01 / 43050KB02

**SERVICE BULLETIN LIST**

SERVICE BULLETIN NUMBER / REV		DATE INCORPORATION OR NO EFFECT	TITLE
SB0521 / 02	May 4/2021	May 25/2022	Field Replacement of sensor to 026709-000

**24-30-11**

SBL 1  
May 23/2023



COMPONENT MAINTENANCE MANUAL  
43B050KB01 / 43B050KB02

PAGE INTENTIONALLY LEFT BLANK

**24-30-11**

SBL 2  
Mar 25/2022



COMPONENT MAINTENANCE MANUAL  
43050KB01 / 43050KB02

**LIST OF EFFECTIVE PAGES**

<b>SUBJECT</b>	<b>PAGE</b>	<b>DATE</b>
TITLE PAGE	T-1 T-2	May 23/2023 May 3/2021
RECORD OF REVISIONS	ROR 1 ROR 2	May 23/2023 Blank
RECORD OF TEMPORARY REVISIONS	RTR 1 RTR 2	Nov 14/2022 Blank
SERVICE BULLETIN LIST	SBL 1 SBL 2	May 23/2023 Blank
LIST OF EFFECTIVE PAGES	LEP 1 LEP 2	May 23/2023 Blank
TABLE OF CONTENTS	TOC 1 TOC 2	May 3/2021 Blank
LIST OF ILLUSTRATIONS	LOI 1 LOI 2	Nov 14/2022 Blank
LIST OF TABLES	LOT 1 LOT 2	May 3/2021 Blank
INTRODUCTION	Intro 1 Intro 2 Intro 3 Intro 4	May 15/2023 May 15/2023 May 15/2023 Mar 25/2022
DESCRIPTION AND OPERATION	1 2 3 4	Mar 25/2022 Mar 25/2022 Mar 25/2022 Mar 25/2022
TESTING AND FAULT ISOLATION	1001 1002 1003 1004 1005 1006 1007 1008 1009 1010 1011 1012 1013 1014 1015	Nov 14/2022 May 23/2023 May 15/2023 May 15/2023 May 15/2023 May 15/2023 May 15/2023 May 15/2023 May 15/2023 May 15/2023 May 15/2023 May 15/2023 May 15/2023 May 15/2023 May 15/2023

<b>SUBJECT</b>	<b>PAGE</b>	<b>DATE</b>
	1016 1017 1018	Mar 25/2022 May 15/2023 Blank
DISASSEMBLY	3001 3002	Nov 14/2022 May 3/2021
CLEANING	4001 4002	Nov 14/2022 Nov 14/2022
CHECK	5001 5002	Nov 14/2022 Mar 25/2022
REPAIR	6001 6002	May 15/2023 Blank
ASSEMBLY	7001 7002	Nov 14/2022 Mar 25/2022
FITS AND CLEARANCES	8001 8002	May 3/2021 Blank
SPECIAL TOOLS, FIXTURES, EQUIPMENT, AND CONSUMABLES	9001 9002	Nov 14/2022 Mar 25/2022
ILLUSTRATED PARTS LIST	10001 10002 10003 10004 10005 10006 10007 10008 10009 10010	Mar 25/2022 May 15/2023 Mar 25/2022 May 3/2021 Nov 14/2022 Nov 14/2022 May 15/2023 Nov 14/2022 Nov 14/2022 May 15/2023
STORAGE (INCLUDING TRANSPORTATION)	15001 15002 15003 15004 15005 15006	Mar 25/2022 Mar 25/2022 Nov 14/2022 Nov 14/2022 Nov 14/2022 Blank

**24-30-11**

LEP 1  
May 23/2023



COMPONENT MAINTENANCE MANUAL  
43B050KB01 / 43B050KB02

PAGE INTENTIONALLY LEFT BLANK

**24-30-11**

LEP 2  
Mar 25/2022



COMPONENT MAINTENANCE MANUAL  
43050KB01 / 43050KB02

**TABLE OF CONTENTS**

<b>PARAGRAPH TITLE</b>	<b>PAGE</b>
INTRODUCTION	<a href="#">Intro 1</a>
DESCRIPTION AND OPERATION	<a href="#">1</a>
TESTING AND FAULT ISOLATION	<a href="#">1001</a>
AUTOMATIC TEST REQUIREMENTS (ATLAS)	N/A
DISASSEMBLY	<a href="#">3001</a>
CLEANING	<a href="#">4001</a>
CHECK	<a href="#">5001</a>
REPAIR	<a href="#">6001</a>
ASSEMBLY	<a href="#">7001</a>
FITS AND CLEARANCES	<a href="#">8001</a>
SPECIAL TOOLS, FIXTURES, EQUIPMENT, AND CONSUMABLES	<a href="#">9001</a>
ILLUSTRATED PARTS LIST	<a href="#">10001</a>
STORAGE (INCLUDING TRANSPORTATION)	<a href="#">15001</a>



COMPONENT MAINTENANCE MANUAL  
43B050KB01 / 43B050KB02

PAGE INTENTIONALLY LEFT BLANK

**24-30-11**

TOC 2  
Mar 25/2022



COMPONENT MAINTENANCE MANUAL  
43B050KB01 / 43B050KB02

**LIST OF ILLUSTRATIONS**

FIGURE	DESCRIPTION	PAGE
Intro 1	Universal Recycling Symbols	<a href="#">Intro 3</a>
1	Nickel Cadmium Battery	<a href="#">1</a>
1001	Process Flow for Battery Restoration	<a href="#">1002</a>
1002	Connector Pinout	<a href="#">1005</a>
1003	Modified <a href="#">T02</a>	<a href="#">1009</a>
1004	Modified <a href="#">T02</a> Level Position	<a href="#">1010</a>
1005	Circuit Diagram	<a href="#">1012</a>
1006	Special Testing Flow Chart	<a href="#">1014</a>
7001	Line and Foam Filler Orientation	<a href="#">7001</a>
7002	Cell Number and Polarity Orientation	<a href="#">7002</a>
IPL Figure 1	Battery, Exploded View (#1 of 4)	<a href="#">10005</a>
IPL Figure 1	Battery, Exploded View (#2 of 4)	<a href="#">10006</a>
IPL Figure 1	Battery, Exploded View (#3 of 4)	<a href="#">10007</a>
IPL Figure 1	Battery, Exploded View (#4 of 4)	<a href="#">10008</a>
15001	Standby Period	<a href="#">15002</a>
15002	Inactive Standby Storage Schedule	<a href="#">15003</a>

**24-30-11**

LOI 1  
Nov 14/2022



COMPONENT MAINTENANCE MANUAL  
43B050KB01 / 43B050KB02

PAGE INTENTIONALLY LEFT BLANK

**24-30-11**

LOI 2  
Mar 25/2022





COMPONENT MAINTENANCE MANUAL  
43B050KB01 / 43B050KB02

**LIST OF TABLES**

TABLE	DESCRIPTION	PAGE
1	Leading Particulars	<a href="#">2</a>
1001	Sensor Values	<a href="#">1006</a>
1002	Initial Discharge (Off-wing Capacity)	<a href="#">1006</a>
1003	Charge Table	<a href="#">1008</a>
1004	Final Charge Voltage Limit	<a href="#">1008</a>
1005	Capacity Check (Second Discharge)	<a href="#">1011</a>
1006	Battery Faults	<a href="#">1015</a>
1007	Cell Faults	<a href="#">1016</a>
1008	Physical Faults	<a href="#">1017</a>
8001	Torque Values	<a href="#">8001</a>
9001	Special Tools	<a href="#">9001</a>
9002	Consumables	<a href="#">9002</a>
15001	Return to Service Following Storage	<a href="#">15001</a>
15002	Refresh Charge	<a href="#">15003</a>

**24-30-11**

LOT 1  
May 3/2021



COMPONENT MAINTENANCE MANUAL  
43B050KB01 / 43B050KB02

PAGE INTENTIONALLY LEFT BLANK

**24-30-11**

LOT 2  
Mar 25/2022



COMPONENT MAINTENANCE MANUAL  
43B050KB01 / 43B050KB02

**INTRODUCTION**

1. General

- A. This manual is written to the ATA Specification 100 and in ASD Simplified Technical English. International Standard units of measure are used in this manual, with imperial units in parentheses.
- B. This manual describes maintenance on components in a workshop. It does not describe maintenance on components when they are installed in aircraft.
- C. Only approved personnel with the necessary skills can do maintenance tasks described in this manual.
- D. This manual contains:
  - (1) Technical data for components
  - (2) Maintenance and replacement procedures for components
  - (3) An Illustrated Parts List (IPL) with data for parts of components. Parts are identified in all sections of the manual by IPL figure and item number.
- E. We make sure of DISASSEMBLY, TESTING AND FAULT ISOLATION, and ASSEMBLY procedures are correct by doing them.

The manual is divided into separate sections:

- (1) Title Page
- (2) Record of Revisions
- (3) Record of Temporary Revisions
- (4) List of Effective Pages
- (5) Table of Contents
- (6) Introduction
- (7) Procedures and IPL Sections

The disassembly and assembly sections contain only specific instructions used on the equipment covered herein. Most standard aerospace practices are not described herein.

This manual provides the information necessary for an experienced shop technician to maintain Saft nickel-cadmium batteries. It describes construction of the battery, as well as techniques used to operate, maintain, and provide care for the battery. Following these instructions will enhance the ability to obtain optimum performance and maximum life from Saft batteries.

All aircraft batteries require checking and maintenance to make sure they are safe when installed and they perform their required functions, especially in emergency conditions on-board the aircraft. Maintenance allows problems to be identified and corrected. The maintenance interval is the period for which correct operation is assured with a low probability of failure and allows elevated levels of MTBUR and MTBF.

Every effort has been made to provide complete and accurate instructions. If a situation arises that is not adequately described in this manual, please contact Saft via the internet at [www.saft.com](http://www.saft.com) or at one of the following addresses:

**24-30-11**

Intro 1  
May 15/2023



COMPONENT MAINTENANCE MANUAL  
43B050KB01 / 43B050KB02

Saft America, Inc. (09052)  
711 Gil Harbin Industrial Boulevard  
Valdosta, Georgia 31601, USA

Saft (F6177)  
26 quai Charles Pasqua  
92300 Levallois-Perret, France

Telephone: +1 (229) 247-2331  
FAX: +1 (229) 247-8486

Telephone: +33 1 58 63 16 00  
FAX: +33 1 58 63 16 18

## 2. Definitions

Warnings call attention to use of materials, procedures, or limits which must be followed precisely to avoid injury to persons.

Cautions call attention to procedures which should be followed to avoid damage to equipment.

Notes call attention to procedures which make the job easier.

## 3. Safety

**WARNING:** EXCEPT FOR THOSE STEPS THAT REQUIRE THE BATTERY TO BE CHARGED, DO ALL STEPS ON DISCHARGED BATTERIES (REFER TO [INITIAL DISCHARGE](#) AND [CELL SHORTING](#)) TO AVOID THE POSSIBILITY OF ELECTRIC SHOCK. TIGHTEN ¼ TURN VENT VALVES ([250](#)) WITH [T01](#) OR ([020](#)) PRIOR TO BEGINNING DISCHARGE. BATTERY CELLS DELIVER VERY HIGH CURRENT WHEN SHORT-CIRCUITED. EXERCISE CAUTION. REMOVE RINGS, WATCHES, NECKLACES, METALLIC BELTS AND OTHER JEWELRY TO AVOID ELECTRIC SHOCK.

**WARNING:** DO NOT TILT THE BATTERY DURING MAINTENANCE, ANY CONTACT OF SKIN WITH ELECTROLYTE CAN CAUSE SEVERE BURNS.

Safety rules differ from one country to another. Always follow local safety regulations.

There are three types of risks

### A. Physical

- (1) Handling: the battery is heavy. When you lift it, bend your legs and not your back.
- (2) Use protective shoes.

### B. Electrical

- (1) Do not wear rings, watches, chains, belt buckles, necklaces, or any other metallic objects.
- (2) Use insulated tools.

### C. Chemical

- (1) For a complete listing of hazards, refer to the safety information sheet available on Saft's website at [www.saft.com](http://www.saft.com).
- (2) Electrolyte is very corrosive and can damage the skin: use gloves and an apron. If it touches the skin, flush the affected part with large quantity of water. Remove contaminated clothing, after flushing begins.
- (3) Electrolyte is very dangerous for eyes, use protective goggles. If the electrolyte comes in contact with an eye, flush it with water and get immediate medical attention.

**24-30-11**

Intro 2  
May 15/2023

## COMPONENT MAINTENANCE MANUAL 43B050KB01 / 43B050KB02

- (4) Saft recommends the use of an amphoteric solution (both acidic and basic behavior) and chelator (able to trap cations as a chelate complex) to neutralize electrolyte according to the local regulation.
- (5) Electrolyte ingestion can cause damage to the throat and respiratory tract. Do not try to vomit and get immediate medical attention.
- (6) Skin contact with nickel can cause chronic eczema.
- (7) Inhalation of cadmium oxide can cause dry throat, headaches, vomiting, chest pain. If inhaled, move to fresh air. If the affected person is not breathing, give artificial respiration. If breathing is difficult, give oxygen and get immediate medical attention.

#### 4. New Battery Commissioning

Saft batteries are shipped discharged. All new Saft batteries that are receiving the initial commissioning within 12 months of the DOM refer to [Initial New Battery Commissioning](#) on page [5001](#) to place into service.

For all new Saft batteries that have not received an initial commissioning within 12 months of the DOM, then refer to [Servicing at end of long-term storage, Table 15001](#).

#### 5. Battery Ratings

##### A. Capacity

Nickel-cadmium batteries are rated in terms of capacity in ampere-hours (Ah) (rated capacity).

Other definitions for battery ratings can be found in EN2570, IEC 60952, and RTCA DO 293.

#### 6. Recycling

All batteries eventually lose their ability to perform and are eligible for scrapping and recycling. Saft takes environmental matters seriously and advocates proper recycling of nickel-cadmium batteries and their components. To that end, Saft operates recycling facilities in both Europe and North America.

Nickel-cadmium batteries contain nickel, cadmium, and potassium hydroxide and should be disposed of properly. In all cases, rely on local and national regulations for proper battery disposal and/or shipping to an appropriate recycling location.



Universal Recycling Symbols  
Figure Intro 1

You can find the nearest recycling collection point on our website at [www.saft.com](http://www.saft.com).

# 24-30-11

Intro 3  
May 15/2023



COMPONENT MAINTENANCE MANUAL  
43B050KB01 / 43B050KB02

7. End of Life

EASA and FAA regulations “Part 145” requires end of life cells to be disposed of in a manner prohibiting them to be returned to service. Other authorities may have requirements less explicit, Saft recommends the following procedure to be followed to provide a means of compliance.

- A. Make sure the appropriate protective measures (refer to [Safety](#) paragraph and Battery Information Sheet (BIS)) are taken.
- B. Make sure the cell is fully discharged (See [Cell shorting](#)).
- C. Break or cut the terminals from the cell. If any electrolyte leakage occurs, make sure the clean-up measures as described in the Battery Information Sheet (BIS).
- D. Dispose of the cell in accordance with applicable transport, health and safety, and recycling regulations. (Refer to [Recycling](#) paragraph)

All batteries eventually lose their ability to perform and are eligible for scrapping and recycling. Saft takes environmental matters seriously and advocates proper recycling of nickel-cadmium batteries and their components. To that end, Saft operates recycling facilities in both Europe and North America

8. Abbreviations

A	Amperes
ASD	AeroSpace and Defence Industries Association of Europe
ATA	Air Transport Association of America
EASA	European Air Safety Authority
FAA	Federal Aviation Authority
Fig.	Figure
IATA	International Transport Air Association
IEC	International Electrotechnical Commission
IMDG	International Maritime Dangerous Goods
IPL	Illustrated Parts List
Max.	Maximum
MTBF	Mean Time Between Failure
MTBUR	Mean Time Between Unscheduled Removal
P/N	Part Number
RTCA	Radio Technical Commission for Aeronautics
V	Voltage

Verification:

Testing / Fault Isolation	March 30, 1997
Disassembly	March 30, 1997
Assembly	March 30, 1997



COMPONENT MAINTENANCE MANUAL  
43B050KB01 / 43B050KB02

**DESCRIPTION AND OPERATION**

1. Description

The Nickel Cadmium Battery (SAFT America Inc. type 50KB01/50KB02) provides power to the standby system or start the auxiliary power unit. It is a nickel-cadmium type with sintered plate construction and uses a potassium hydroxide electrolyte. The battery consists of a case, cover, ten (10) cell assemblies, one (1) dummy cell, and a temperature sensor harness.

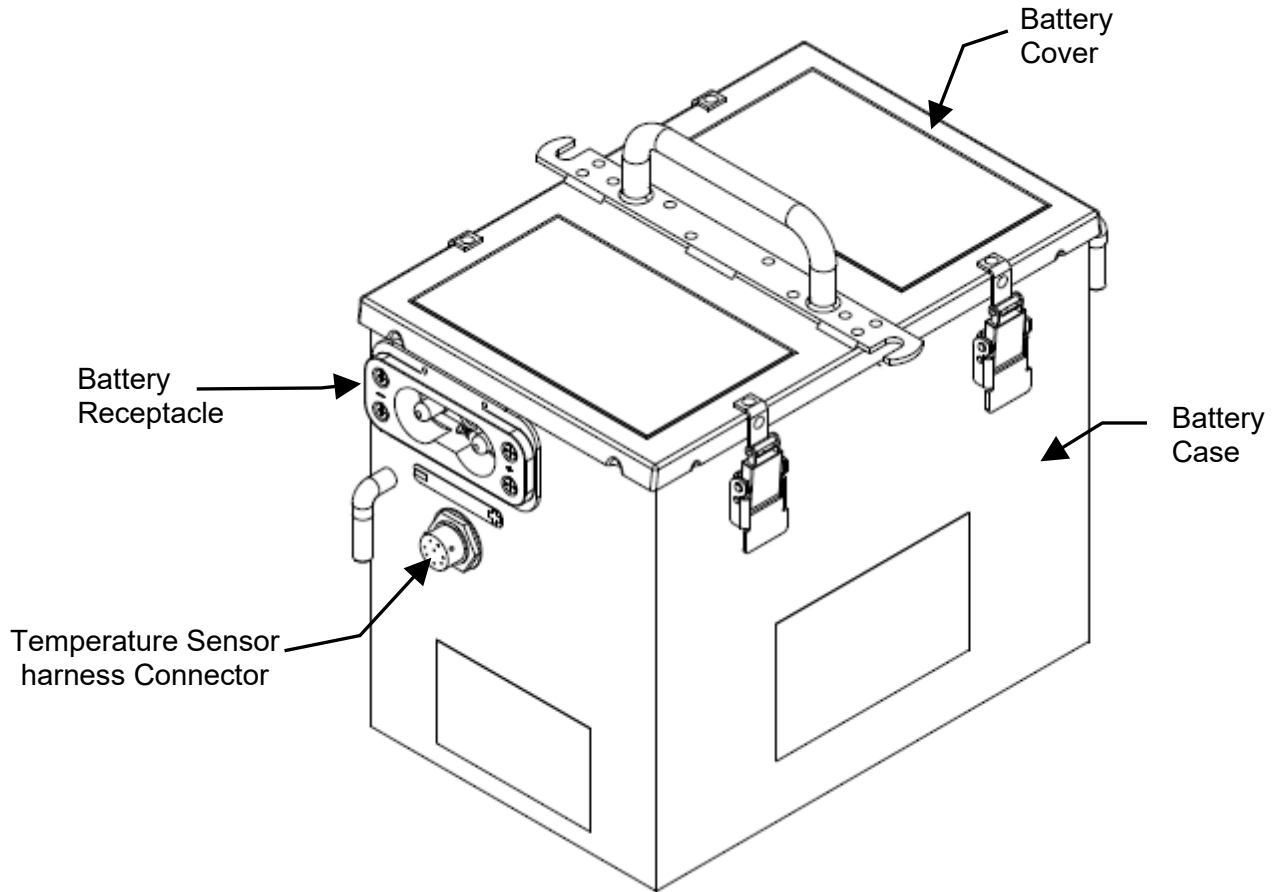

Nickel Cadmium Battery  
Figure 1



COMPONENT MAINTENANCE MANUAL  
43B050KB01 / 43B050KB02

PARAMETER	VALUES
Voltage: Nominal	12.0 Volts
Weight 43B050KB01 43B050KB02	28.58 kg (63 pounds) maximum 27.67 kg (61 pounds) maximum
Dimensions (Maximum): Height Length Width	261.62 mm (10.30 inches) 293.62 mm (11.56 inches) 194.31 mm (7.65 inches)
Dummy Cell	1
Number of Cell Assemblies	10
Cell Model	Saft-Type Cell, 43B050AC01-2
Vent Valve	MS Style (¼ turn)
1.0C <sub>1</sub> A Rate	50.0A
0.5 C <sub>1</sub> A Rate	25.0A
0.1 C <sub>1</sub> A Rate	5.0A
Rated Capacity (C <sub>1</sub> )	50 Ampere-hours at 1.0C <sub>1</sub> A
Venting Pressure	0.14 to 0.69 bar (2 to 10 psi)
Cell Assembly Case Material	Polyamide
Battery Case Material	Stainless Steel, Fluidized Black
Electrolyte	Potassium Hydroxide
Recommended Storage Temperatures	+5°C to +35°C (+41°F to +95°F)
Ambient Temperature	+15°C to +30°C (+59°F to +86°F)

Leading Particulars  
Table 1

2. Operation

A. Flight charging

The battery is charged on the aircraft by an on-board charger. The charge control device provides a voltage signal to the charger to charge according to the battery temperature range.

**24-30-11**





COMPONENT MAINTENANCE MANUAL  
43B050KB01 / 43B050KB02

B. Maintenance

(1) Maintenance interval basis

The aircraft manufacturer and/or operator is responsible for the definition of maintenance interval based on the use profile of the batteries installed on the aircraft. The maintenance interval has two main factors:

- Energy available for emergency requirements
- Electrolyte consumable reserve.

Both factors depend on the battery charging system, operating temperature, discharge magnitude, charge cycles, flight duration, ground operation, and battery technology.

The higher voltage per cell applied, the higher overcharge current and capacity the battery receives.

The overcharged capacity is directly related to the electrolysis of water from the electrolyte, and hence the consumption of the electrolyte reserve. For every 3 Ah of overcharge, 1 cm<sup>3</sup> (0.06 in<sup>3</sup>) of water is consumed via electrolysis. Once the water reserve has been consumed, the result is:

- Dried out cells with a significant risk of permanent damage
- Internal short circuit
- Overheating
- Thermal runaway.

(2) Maintenance interval extensions

To validate maintenance interval extension, the recommendation is to have the Operator and Saft review the maintenance records for a minimum period of 12 months.

The data includes, but is not limited to, the recording of aircraft flight hours accrued while installed, its removal date, inspection date, off-wing capacity, and water consumption as required by this CMM.

As with any maintenance extension, subsequent monitoring of the water addition and electrical performance upon removal from the aircraft must be done to detect any adverse effects and, if necessary, re-adjust the maintenance interval accordingly. To determine the electrical performance more readily after aircraft removal, the battery may be floated 31V for 1.5 hours if the aircraft uses a dedicated charger or 28.5V for 1.5 hours if it floats on the aircraft bus before performing the Initial discharge (off-wing capacity) test.



COMPONENT MAINTENANCE MANUAL  
43B050KB01 / 43B050KB02

C. Battery data requirements

Maintenance information is required for any Saft battery evaluation to determine its condition and health. Throughout this manual there are multiple steps requiring specific information be recorded to maintain a battery service history. The information provided not will only reflect the batteries airworthiness, but also provide information to assist in any battery issue investigations required at the factory. As a minimum the items identified below are required for each battery maintenance step/action.

- (1) Record the date the battery was received, and time testing started.
- (2) As required for all discharges, record the duration the first cell reaches 1.0V.
- (3) As required during charges,
  - (a) Record the cell voltages at the start of the charge, at the end of the main charge, and the last 30 minutes of the final charge.
  - (b) Record the water added to each cell during the last 30 minutes of the final charge.
- (4) As required for special testing, record location and reason for cell replacement either voltage or capacity.
- (5) Record the date the battery is returned to service.



COMPONENT MAINTENANCE MANUAL  
43B050KB01 / 43B050KB02

**TESTING AND FAULT ISOLATION**

1. General

This section contains battery functional tests and fault isolation information. Test procedures are written in step-by-step formats that follow the process flow outlined in [Figure 1001](#). Fault isolation is presented in chart form (refer to [Table 1006](#), [Table 1007](#), and [Table 1008](#)).

**NOTE:** The ( ) part identification numbers herein are [IPL Figure 1](#) item numbers.

**NOTE:** All voltage readings are DC unless otherwise stated.

2. Required Test Equipment

**NOTE:** Test equipment with equivalent specifications can be used.

Refer to [Special Tools, Fixtures, Equipment, and Consumables](#) for listing of Standard Tools.

3. Maintenance Procedures

In addition to the checks specified for airborne or ground use, in normal service SAFT 50KB01 or 50KB02 batteries require the following maintenance operations.

A. Restoration Procedure

Outlined in [Figure 1001](#) is a step-by-step process flow. A request for overhaul or restoration should follow this same procedure.

**NOTE:** Overhaul by some airworthiness authorities is defined as an item that has been disassembled, cleaned, inspected, repaired as necessary, reassembled, and tested. To identify this process the entire battery must require total disassembly, thorough cleaning, assembly, and testing.

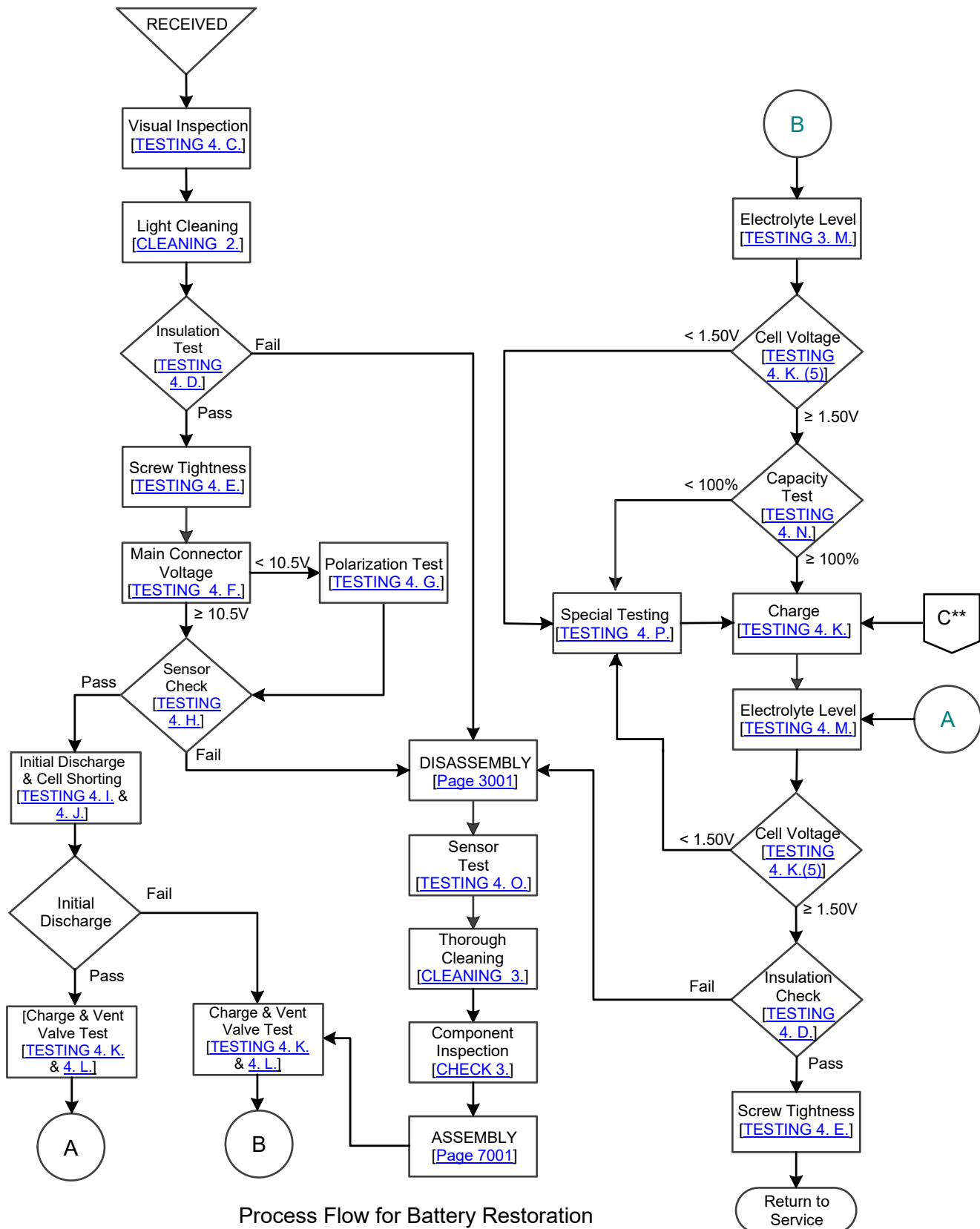

Process Flow for Battery Restoration  
Figure 1001

\*\*From [Table 15001](#)



COMPONENT MAINTENANCE MANUAL  
43B050KB01 / 43B050KB02

4. Testing

A. Test conditions

(1) Facilities and equipment

**CAUTION:** FUMES FROM LEAD ACID BATTERIES OR SMALL TRACES OF SULFURIC ACID ENTERING A NI-CD BATTERY CAN CAUSE PERMANENT DAMAGE.

- (a) Service facilities for Ni-Cd batteries must be entirely separate from those for lead acid batteries.
- (b) Equipment used to service lead acid batteries must not be used to maintain Ni-Cd batteries.

(2) For optimum results conduct all tests with the battery temperature at Ambient Temperature, unless otherwise noted in this manual.

B. Test equipment

Refer to [Special Tools, Fixtures, and Equipment, and Consumables](#) for test equipment recommendations.

C. Visual Inspection

Items found may require doing immediate disassembly while the majority do not. If a finding does not require going to disassembly procedure, then specific instructions are provided after the battery has been received its initial discharge.

- (1) Visually inspect battery cover ([050](#)) for dents, distortion, or other damage and replace as needed.
- (2) Visually inspect battery case ([010](#) or [010A](#)) for dents, distortion, or other damage. If found, identify the case for replacement.
- (3) Visually inspect visible portions of each cell ([240](#)) for any evidence of electrolyte leakage and damage.
  - (a) Damaged cells ([240](#)) or dummy cells ([230](#) or [230A](#)) must be marked for replacement or further cleaning.

**NOTE:** Excessive electrolyte leakage will cause the battery to fail the Battery insulation test.

- (b) Excessive salts around the terminal posts gives an indication of possible leakage from terminal O-ring.
- (c) When inspection reveals electrolyte leakage from the cell ([240](#)) at the vent hole opening, replace the defective O-ring ([260](#)).

**WARNING:** USE CARE NOT TO TILT CELLS WHILE VENT VALVES ARE OPEN OR REMOVED; CONTACT OF ELECTROLYTE WITH CAN CAUSE SEVERE BURNS.

- 1 Using [T01](#) or ([020](#)), ¼ turn to loosen and remove the vent valve ([250](#)) from the cell ([240](#)).
- 2 Remove and replace defective O-rings ([260](#)) from the vent valve ([250](#)).

**24-30-11**

1003  
May 15/2023



COMPONENT MAINTENANCE MANUAL  
43B050KB01 / 43B050KB02

- 3 Using [T01](#) or [\(020\)](#), tighten the ¼ turn vent valve ([250](#)) onto the cell ([240](#)).
  - (4) Inspect the screws ([160](#)), ([270](#)), lock washers ([170](#)), ([280](#)), washers ([180](#)), ([290](#)), and links ([300](#) to [320](#)) to ensure it is free of bends, tarnish, corrosion, burns, or loss of plating. Minor tarnish can be polished off with a fine wire brush. Identify defective hardware to be replaced after the initial discharge.
  - (5) Check all ventilation openings to make sure that they are clean and clear.
  - (6) Inspect the power connector ([130](#)) pins for condition; replace the power connector ([130](#)) if the pins show any trace of arcing or excessive oxidization.
- D. Battery insulation
- NOTE:** A breakdown in electrical insulation between the cells and the battery case will result in a “leakage” current, which, over a period of time, can discharge the battery.
- NOTE:** Method A or B may be used to check the insulation breakdown.
- (1) Method A
    - (a) Set up the multimeter and meter leads for a measurement of 250mA.
    - (b) The positive lead from the meter to:
      - 1 the positive terminal of each cell.
    - (c) If there is a reading of zero, the insulation test is a “Pass”; otherwise, the insulation test is a “Fail”.

**NOTE:** If, after cleaning the battery and assuring that everything is dry, a leakage current is still indicated by a deflection of the needle, then one or more cells ([240](#)) is defective. Isolate and replace the defective cell(s).
  - (2) Method B
    - (a) On a completely assembled battery using megohmmeter under a continuous 250V, measure the insulation resistance between the metal box and
      - 1 the positive terminal of each cell.
    - (b) The value measured must be  $\geq 10\text{M}\Omega$  while under continuous 250V.
    - (c) If the reading meets the above criteria ( $\geq 10\text{M}\Omega$ ), the insulation is a “Pass”; otherwise, the insulation test is a “Fail”.

**NOTE:** If, after cleaning the battery and assuring that everything is dry, the resistance is still  $< 10\text{M}\Omega$ , one or more cells ([240](#)) is defective. Isolate and replace the defective cell(s).
- E. Socket head screw ([160](#)), ([270](#)) tightness  
Check that the tightness on each socket head screw ([160](#)), ([270](#)) per [Table 8001](#).
- F. Battery voltage  
Measure and confirm the voltage at the battery connector is greater than or equal to 10.5V.

G. Polarization test

- (1) Charge the battery at  $0.1C_1$  for 1.5 hours.
- (2) Keep the battery in open circuit for 1 hour.
- (3) Measure the open circuit voltage of each cell.
  - (a) Mark for replacement each cell (240) with zero (0)V or negative polarity. If any cell (240) is marked for replacement, the polarization test is a "Fail".
  - (b) If all cells are above zero (0)V, the polarization test is a "Pass".

H. Sensor harness (190 or 340) check

- (1) If any part of the sensor harness (190 or 340) is damaged, the entire assembly must be replaced with sensor harness (340).
- (2) Identification of the sensor harness to be tested

Prior to performing this check, you must determine which style sensor is installed in the battery.

  - (a) Part Marking
    - 1 P/N 022036-000 (190) sensor housing is marked "022036-000"
    - 2 P/N 026709-000 (340) sensor housing is marked "P/N 026709-000"

**NOTE:** Refer to [Figure 1002](#) for pinout locations.

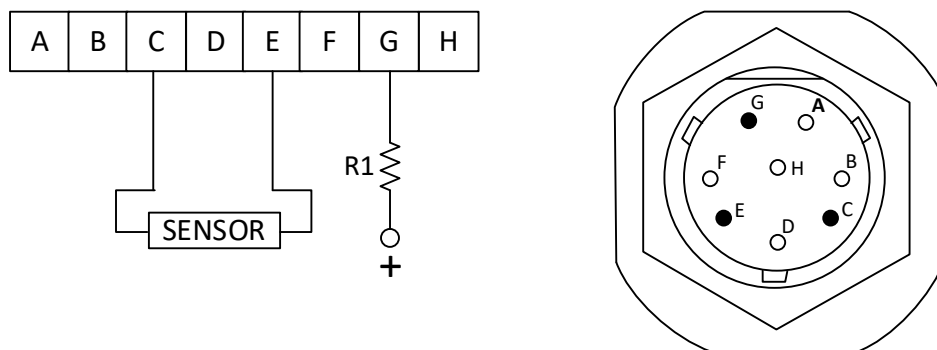

Connector Pinout  
Figure 1002

**NOTE:** A climate chamber or alternate methods may be used provided the temperatures below are achieved.

(3) Sensor harness (190)

Verify the sensor values at the temperature as required by [Table 1001](#).

- (a) Any erratic readings represent a failure and must be replaced with sensor harness (340) by ordering kit (330).



COMPONENT MAINTENANCE MANUAL  
43B050KB01 / 43B050KB02

PINS	VALUES @ 25 ± 10°C (77 ± 18°F)
Positive Terminal and Pin G	1000Ω ± 100Ω
Pins C and E	2000Ω ± 20Ω
Pins C to Battery Case	> 20MΩ
Pins E to Battery Case	> 20MΩ

Sensor Values  
Table 1001

- (4) Sensor harness (340)
- (a) Provide a voltage source of 13.3V ± 0.3V.  
**NOTE:** The battery voltage can be used if it is within this limit.
  - (b) Connect pin E of the sensor (340) connector to the negative terminal of the voltage source.
  - (c) Connect pin C of the sensor (340) connector to the positive terminal of the voltage source.
  - (d) The sensor harness (340) is defective if it does not meet the following:
    - 1 Voltage meter reading is > 1.0V
    - 2 Voltage difference > 1.0V for the source voltage – meter reading
  - (e) The sensor harness (340) is defective if the resistance between pin G and positive terminal of the battery is not equal to 1000Ω ± 100Ω.

I. Initial discharge (off-wing capacity)

The purpose of this procedure is to discharge the battery to a known state of charge and determine the battery capacity from the aircraft.

- (1) Using T01 or (020), verify the ¼ turn vent valve (250) is tightened on each cell (240).
- (2) Discharge the battery at a rate listed in Table 1002 until the battery reaches 10.0V. Record the times the first cell reaches 1.0V and battery reaches 10.0V.  
**NOTE:** It is important that the discharge current be continually maintained at the selected value, and that the time of discharge be measured accurately.
- (3) **NOTE:** If a cell goes to zero volts or reverses polarity during the discharge, short out the cell's terminals for the remainder of the discharge.

DISCHARGE		MINIMUM TIME FOR FIRST CELL TO 1.0V
RATE (C <sub>1</sub> )	CURRENT (AMPS)	
0.5	25.0	122.0 MINUTES
1.0	50.0	60.0 MINUTES

Initial Discharge (Off-wing Capacity)  
Table 1002

24-30-11

1006  
May 15/2023





COMPONENT MAINTENANCE MANUAL  
43B050KB01 / 43B050KB02

- (4) If defective case ([010](#) or [010A](#)), power connector ([130](#)), or links ([300](#) to [320](#)) were found during the visual inspection, do [DISASSEMBLY](#) AND [ASSEMBLY](#) to replacement.
  - (5) For each cell ([240](#)) marked for replacement, do [Cell replacement](#) in [REPAIR](#).
  - (6) Remove and replace as needed screws ([160](#)), ([270](#)), lock washers ([170](#)), ([280](#)) and washers ([180](#)), ([290](#)) using [Cell hardware replacement](#) in [REPAIR](#).
  - (7) Initial discharge results
    - (a) If the discharge time the first cell reaches 1.0V equals or exceeds the value shown in [Table 1002](#) for the discharged rate, then the battery capacity is a "Pass".
    - (b) If the discharge time the first cell reaches 1.0V is less than the value shown in [Table 1002](#) for the discharged rate, then the battery capacity is a "Fail".
- J. Cell shorting
- (1) Using [T01](#), verify the ¼ turn vent valves ([250](#)) are tightened on each cell ([240](#)).
  - (2) Discharge each cell in the battery to 0V using one of the two methods below:

**NOTE:** It is not necessary to have a rest period between a discharge and cell shorting.

    - (a) Method A
      - 1 Continue to discharge the battery per [Table 1002](#) until each cell is < 1.0V, then connect a [T03](#) across its terminals. After all the cells have been shorted, leave the devices in place for 12 to 24 hours.
    - (b) Method B
      - 1 Continue to discharge the battery per [Table 1002](#) until each cell is < 0.5V, then connect a shorting clip across its terminals. After all the cells have been shorted, leave these clips on for 16 to 24 hours.
  - (3) At completion of Method A or B, remove the shorting devices
  - (4) If no cell(s) are marked for replacement, then return to [Figure 1001](#) utilizing the "Pass" or "Fail" results of the [Initial discharge](#).
  - (5) If cell(s) were marked for replacement, do [Cell replacement](#) in [REPAIR](#).
- K. Charge
- (1) Allow the battery to cool to ambient temperature.
  - (2) Remove the cover ([050](#)).
  - (3) Prior to charging the battery, ¼ turn to loosen (do not remove) all vent valves ([250](#)) from cell ([240](#)). Ensure that the shorting spring has been removed.

**NOTE:** If required by [Figure 1001](#), it is recommended to do [Vent valve test](#) during the charge.
  - (4) Charge the battery using one of the methods in [Table 1003](#).
    - (a) Record the cell ([240](#)) voltages at the start and end of the main charge (Step 1), and the last 30 minutes of the final charge (Step 2).



COMPONENT MAINTENANCE MANUAL  
43B050KB01 / 43B050KB02

- 1 If the start cell voltage of the main charge (Step 1) goes above 1.50V, add to the cell about 10 cm<sup>3</sup> (0.61 in<sup>3</sup>) of [M01](#).
- 2 During the last during the last 30 minutes of the final charge (Step 2), adjust the [Electrolyte level](#), and check the [Minimum final charge voltage](#).

Charge Table			
Main Charge (Step1)			Final Charge (Step 2)**
Current	Minimum Time*	End of Main Charge Criteria	Current and Time
0.1C <sub>1</sub> A (5.0A)	10h	Every cell >1.5V or 12h whichever comes first	0.1C <sub>1</sub> A (5.0A) for 4h
0.5C <sub>1</sub> A (25.0A)	2h	Every cell >1.55V or 2.5h whichever comes first	0.1C <sub>1</sub> A (5.0A) for 4h
1.0C <sub>1</sub> A (50.0A)	1h	Every cell >1.57V or 1.25h whichever comes first	0.1C <sub>1</sub> A (5.0A) for 4h

\* Minimum time applies to a battery previously discharge to 10.0V.

\*\* During the last 30 minutes do [Electrolyte level](#) and confirm minimum voltage criteria in [Table 1004](#).

Charge Table  
Table 1003

(5) Minimum final charge voltage

During the last 30 minutes of final charge (Step 2) check that the cell ([240](#)) voltages are within the value shown in [Table 1004](#) (identify any cell ([240](#)) that does not comply), do [Special testing](#) per [Figure 1001](#).

CELL VOLTAGE (Last 30 minutes at 0.1C <sub>1</sub> A)
≥ 1.50V

Final Charge Voltage Limit  
Table 1004

L. Vent valve test

**NOTE:** The vent valve test should be done once a year of battery operation or every maintenance interval, whichever is longer. This test is not necessary if all the vent valves ([250](#)) are replaced with new Saft valves each year or maintenance interval, whichever is longer.

**NOTE:** It is recommended to do this test while the battery is on charge.

**CAUTION:** THE CELL OPENINGS MUST BE COVERED WITH A CLEAN, DAMP CLOTH TO PREVENT ENTRY OF FOREIGN MATTER.

- (1) Check the operation of the vent valve assemblies as follows:
  - (a) Using [T01](#) or ([020](#)), install the ¼ turn vent valve ([250](#)) that contains O-ring ([260](#)) onto the [T05](#) fixture.
  - (b) Attach the fixture [T05](#) to a compressed air line through an adjustable pressure reducing valve limited to 1.38 bar (20 psi).

## COMPONENT MAINTENANCE MANUAL 43B050KB01 / 43B050KB02

- (c) Slowly raise the air pressure to a 1.38 bar (20 psi) maximum to test the functionally below.
- (d) Immerse the valve and end of fixture in water, and slowly raise the pressure. Make sure the valve opens between 0.14 to 0.69 bar (2 psi and 10 psi).
- (e) Reuse only those vent valves found to open in the 0.14 to 0.69 bar (2 psi and 10 psi) range. Re-soak vent valves that do not open at 0.69 bar (10 psi) until they do open (refer to [CLEANING](#) on page [4001](#)). Discard vent valves ([250](#)) which are not gas tight at low pressure.

### M. Electrolyte level

This procedure is to be carried out during final charge at 0.1C<sub>1</sub> amps during the last 30 minutes of final charge.

**WARNING:** USE CARE NOT TO TILT CELLS WHILE VENT VALVES ARE LOOSENED OR REMOVED; CONTACT OF ELECTROLYTE WITH SKIN CAN CAUSE SEVERE BURNS.

**CAUTION:** USING ANYTHING OTHER THAN [M01](#) IN NICKEL-CADMIUM CELLS WILL CAUSE ELECTROLYTE CONTAMINATION AND DAMAGE. DO NOT RE-USE WATER REMOVED FROM CELLS.

- (1) Prior to using the indicator level assembly [T02](#) check to be sure that you have modified the tube by the following procedure
  - (a) Measure ¾ inches (19 mm) from the tip of the tube and make a mark.
  - (b) Drill a 3/32 (2.5mm) hole through one side of the tube at the mark as shown in [Figure 1003](#).

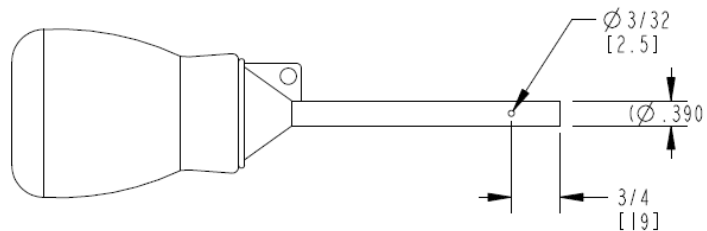

Modified [T02](#)  
Figure 1003

- (2) Before adjusting the electrolyte level, remove the ¼ turn vent valves ([250](#)) with [T01](#) or ([020](#)) from cells ([240](#)). Cover the cells with a clean damp cloth to prevent entry of foreign matter.
  - (a) Immerse the valves and their O-rings in [M01](#) and let them soak to dissolve any salts.
- (3) Inserting modified [T02](#) into the cell opening until the tip of the tube rests on the bottom of the plastic baffle inside the cell ([240](#)). Refer to [Figure 1004](#).

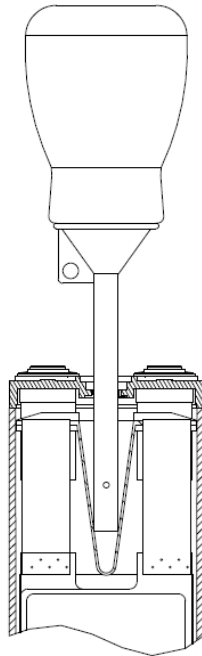

Modified [T02](#) Leveling Position  
Figure 1004

- (4) Squeeze the ball and check for any liquid in the modified [T02](#) indicator level while in cell ([240](#)).
  - (a) Any excess liquid in the cell ([240](#)) will be drawn into the indicator level until the electrolyte level is correct.
  - (b) If the liquid level is too low, the indicator level will remain empty in the cell.
    - 1 Draw an approximate amount of [M01](#), such as 5 cm<sup>3</sup> (0.31 in<sup>3</sup>) into the modified [T02](#) and inject it into the cell ([240](#)).
    - 2 With the modified [T02](#) tip of the tube resting on the bottom of the plastic baffle inside the cell, slowly squeeze the ball.
    - 3 If the modified [T02](#) remains empty, repeat steps 1 and 2.
    - 4 At the point in step 2 when some excess liquid is drawn into the modified [T02](#), the correct level for that cell ([240](#)) has been reached. Expel the excess liquid into a separate container for proper disposal of hazardous waste.
- (5) Using [T01](#) or ([020](#)), tighten the ¼ turn vent valve ([250](#)) on each cell ([240](#)).



COMPONENT MAINTENANCE MANUAL  
43B050KB01 / 43B050KB02

N. Capacity check (second discharge)

The purpose of this discharge procedure is to verify battery capacity.

- (1) Prior to doing the capacity check, [Charge](#) and [Electrolyte leveling](#) must be done.
- (2) Using [T01](#) or [\(020\)](#), verify the ¼ turn vent valve ([250](#)) is installed on each cell ([240](#)). Discharge the battery at one of the current rates shown in [Table 1005](#) until the battery reaches 10.0V to determine and record the times the first cell reaches 1.0V and battery reaches 10.0V.

**NOTE:** It is important that the discharge current be continually maintained at the selected value, and that the time of discharge is measured accurately.

**NOTE:** If a cell goes to zero volts or reverses polarity during the discharge, short out that cell's terminals by inserting a [T03](#) between its terminals for the remainder of the discharge.

DISCHARGE		MINIMUM TIME FOR FIRST CELL TO 1.0V
RATE (C <sub>1</sub> )	CURRENT (AMPS)	
0.5	25.0	104.0 MINUTES
1.0	50.0	51.0 MINUTES

Capacity Check (Second Discharge)  
Table 1005

- (3) If the time the first cell reached 1.0V equals or exceeds the values shown in [Table 1005](#) at the discharge rate, then the capacity is ≥ 100%. Allow the battery to rest at least 2 hours and return to [Figure 1001](#).
- (4) If the time the first cell reached 1.0V is less than the value shown in [Table 1005](#) at the discharge rate, then the capacity is < 100%. Do Special as shown in [Figure 1001](#).

O. Sensor harness ([190](#) or [340](#)) test

This test shall be done for a [Battery insulation](#) check failure or disassembly, otherwise the test should be done on an annual basis by doing [DISASSEMBLY](#) to allow the harness to be removed and tested.

**WARNING:** A FULLY ASSEMBLED BATTERY MUST BE IN A FULLY DISCHARGED CHARGE STATE TO PREVENT INJURY, REFER TO [CELL SHORTING](#).

**NOTE:** A climate chamber or alternate methods may be used, provided the temperatures below are achieved.

If any part of the sensor harness ([190](#) or [340](#)) is damaged or fails any portion of this test, the entire assembly must be replaced with new Saft Sensor harness ([340](#)).

**NOTE:** Refer to [Figure 1002](#) for pinout locations.

- (1) Confirm the battery was discharged and disassembled.
- (2) Connect the sensor harness as indicated in the circuit diagram of [Figure 1005](#).

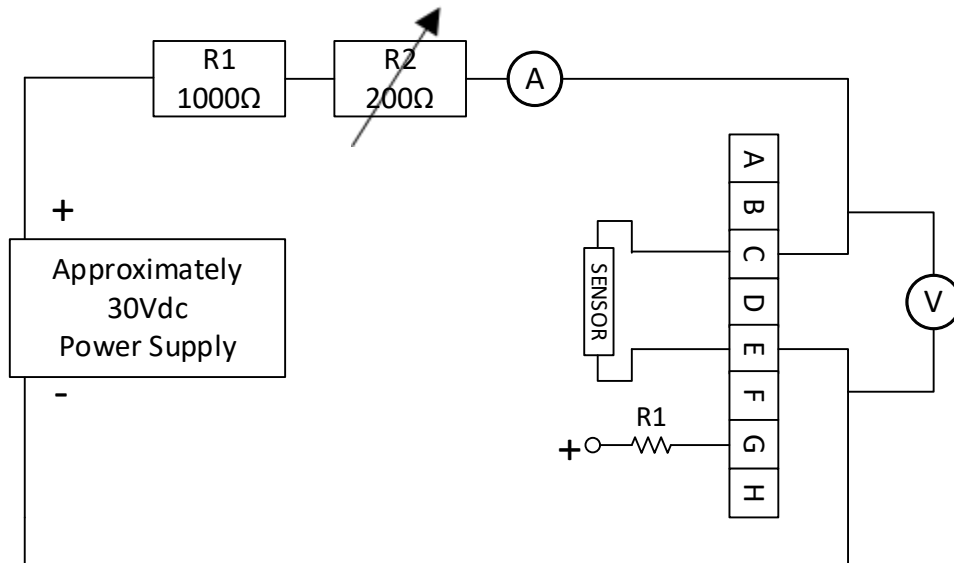

Circuit Diagram  
Figure 1005

- (3) Adjust the variable resistor to obtain a current of 17.5 milliamperes.
- (4) Immerse the sensor unit and NOT THE CONNECTOR in a mixture of ice and water that is contained in a glass or plastic container.
- (5) Allow the sensor unit to remain in the ice and water mixture for 10 minutes while stirring the mixture. Readjust the current, if necessary, to maintain 17.5 milliamperes.
  - (a) Read and note the voltage across the sensor. To be acceptable the voltage measurement must be between 11.045 and 11.280 volts.

If any part of the sensor harness ([190](#) or [340](#)) is damaged or fails any portion of this test, the entire assembly must be replaced with new Saft Sensor harness ([340](#)).

#### P. Special testing

These procedures are to be followed for a battery that does not meet capacity or if the end of charge cell voltage < 1.50V during the final charge. Refer to [Figure 1006](#) flow chart.

**NOTE:** For a new battery or one removed from the aircraft that has not passed capacity after doing the special testing more than 3 times, it is recommended to replace noncompliant cells with new Saft cells ([240](#)) (refer to [All cell replacement](#) recommendation in [REPAIR](#)).

**NOTE:** For battery from long-term storage, several complete charge/discharge cycles may be needed to restore performance.

#### (1) Special testing decision

For a battery with < 100% capacity, do [Low capacity \(Special testing\)](#). Otherwise for a battery with any cell voltage < 1.50V, do [Supplementary test](#).



COMPONENT MAINTENANCE MANUAL  
43B050KB01 / 43B050KB02

- (2) Low capacity (Special testing)
- (a) Loosen, but do not remove all ¼ turn vent valves (250) on cells (240) and fully charge the battery as outlined in [Charge](#) section.
  - (b) For a battery with any cell (240) voltage < 1.50V during the final charge, do [Supplementary test](#). Otherwise, do [Capacity test \(Special testing\)](#).
- (3) Supplementary test
- (a) Charge at 0.1C<sub>1</sub>A for an additional 5 hours and monitor the voltage of the individual cells (240) every 30 minutes.  
**NOTE:** The additional 0.1C<sub>1</sub>A 5-hour charge may be stopped once all the cells are ≥ 1.50V.
    - 1 Identify for replacement any cell (240) with voltage < 1.50V.
    - 2 During the last 30 minutes of this charge, adjust the [Electrolyte level](#) and tighten the ¼ turn vent valves (250) on top of each cell (240).
    - 3 Do [Cell replacement](#) for cells (240) marked for replacement. Otherwise, do [Capacity test \(Special testing\)](#).**NOTE:** If more than one cell (240) was replaced due to low charge voltage during the current maintenance cycle, then the replacement of all cells should be considered. Refer to [Cell replacement](#) in [REPAIR](#).
- (4) Capacity test (Special testing)
- (a) Using [T01](#) or (020), verify the ¼ turn vent valve (250) is installed on each cell (240).
  - (b) Discharge the battery at a rate shown in [Table 1005](#) until the battery reaches 10.0V. Record the time and current the battery reached 10.0V and identify the noncompliant cells with voltage < 1.0V.
  - (c) If the time the first cell (240) reached 1.0V equals or exceeds the values shown in [Table 1005](#) at the applicable discharge rate, then return to [Figure 1001](#). Otherwise, repeat this procedure [Low capacity \(Special testing\)](#) or refer to [Fault Isolation](#).
    - 1 For noncompliant cells (240) that failed this capacity test 3 times, replace with new Saft cells (240) (refer to [Cell replacement](#) in [REPAIR](#)).

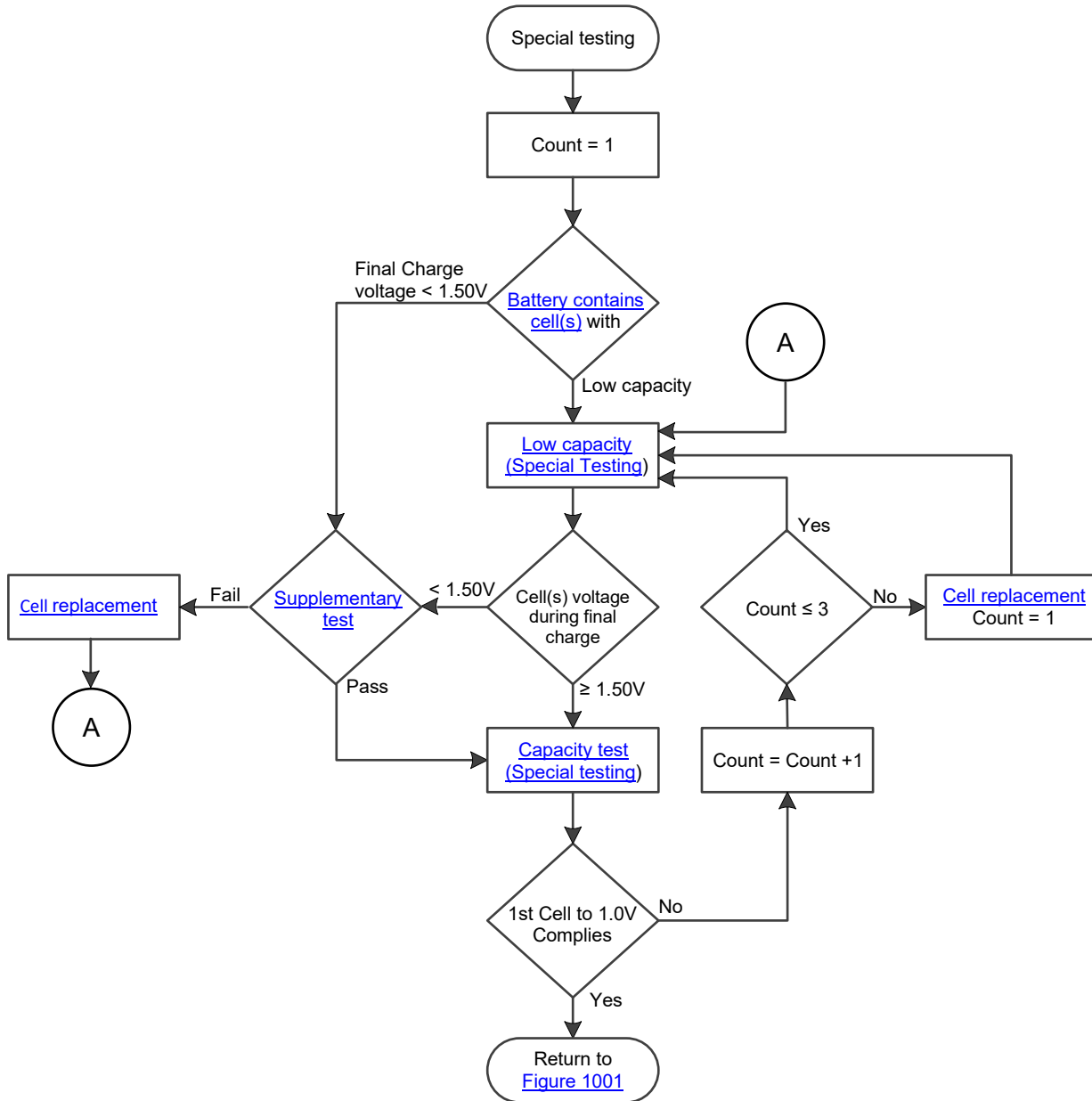

Special Testing Flow Chart  
Figure 1006





COMPONENT MAINTENANCE MANUAL  
43B050KB01 / 43B050KB02

5. Fault Isolation

Fault isolation information is presented in [Table 1006](#), [Table 1007](#), or [Table 1008](#) as a guide to locate the cause of malfunction and isolating the cause to a specific component.

TROUBLE	PROBABLE CAUSE	REMEDY
(1) No battery voltage	(a) Defective electrical connector (not making contact). (b) Broken or loose terminal links, socket head screws	Check electrical connections Replace if required using <a href="#">DISASSEMBLY</a> and <a href="#">ASSEMBLY</a>
(2) Low Insulation	(a) Leakage of electrolyte (b) Incorrect electrolyte level  (c) Reverse cell polarity (d) Condensation / Contamination (e) Improper cleaning (f) Loose or damage vent valve  (g) Damaged cell case  (h) Charge rate too high	Do <a href="#">Thorough Cleaning</a> , <a href="#">ASSEMBLY</a> , <a href="#">Charge</a> , <a href="#">Electrolyte level</a>  Tighten or replace vent valve, do <a href="#">Thorough Cleaning</a> , <a href="#">ASSEMBLY</a> , <a href="#">Charge</a> , <a href="#">Electrolyte level</a>  Do <a href="#">Thorough Cleaning</a> , <a href="#">Cell replacement</a> , <a href="#">ASSEMBLY</a> , <a href="#">Charge</a> , <a href="#">Electrolyte level</a>  Investigate the cause of the excessive charge. Do <a href="#">Thorough Cleaning</a> , <a href="#">ASSEMBLY</a> , <a href="#">Charge</a> , <a href="#">Electrolyte level</a>
(3) Loss of battery capacity	(a) Normal wear after long service (b) Exceptionally heavy use	Do <a href="#">Special testing</a>

Battery Faults  
Table 1006



COMPONENT MAINTENANCE MANUAL  
43B050KB01 / 43B050KB02

TROUBLE	PROBABLE CAUSE	REMEDY
(1) All cells have reserve consumed	(a) Charged more than allowed or charged at high temperature. (b) Previous maintenance has not been done (c) Maintenance interval too long	Examine the cause of the excessive charge. Do <a href="#">Charge</a> , and be sure what for the next maintenance interval.  If this continues the maintenance interval should be done reduced.
(2) High water consumption in one or more cells	(a) Damaged separator when the water consumption is less than 30% below the average value of added water in all cells. (b) Cell imbalance when water addition is more than 30% above the average value of added water in all cells.	Do <a href="#">Charge</a> , <a href="#">Supplementary test</a> .  Do <a href="#">Thorough Cleaning</a> , <a href="#">Cell replacement</a> , <a href="#">ASSEMBLY</a> , <a href="#">Charge</a> , <a href="#">Electrolyte level</a>
(3) Abnormally high cell voltage at beginning of charge	(a) Dry cell	Add 5 to 10 cm <sup>3</sup> (0.31 to 0.61 in <sup>3</sup> of distilled water, do <a href="#">Electrolyte level</a> after final charge
(4) Zero Voltage on cell	(a) Short-circuited cell	Do <a href="#">Cell replacement</a>
(5) Low cell voltage at end of charge	(a) Separator damage	Do <a href="#">Cell replacement</a>
(6) Low cell capacity	(a) Normal wear from long service	Do <a href="#">Cell replacement</a>
(7) Cell with a swollen case	(a) Cell operated with low electrolyte level, deterioration of separator and damaged plates	Do <a href="#">Cell replacement</a>

Cell Faults  
Table 1007



COMPONENT MAINTENANCE MANUAL  
43B050KB01 / 43B050KB02

TROUBLE	PROBABLE CAUSE	REMEDY
(1) Tarnished or burned terminal connectors	(a) Loose socket head screws and links	Clean and torque per <a href="#">Table 8001</a>
(2) Exposed copper material on power connector pin	(a) Mechanical damage (b) Electrical arcing	Replace component using <a href="#">DISASSEMBLY</a> and <a href="#">ASSEMBLY</a>
(3) Melted plastic on connectors	(a) Overheat due to contact resistance	Replace component using <a href="#">DISASSEMBLY</a> and <a href="#">ASSEMBLY</a>
(4) Corroded links	(a) Operation in acidic atmosphere  (b) Inadequate greasing  (c) Mechanical damage to protective nickel-plating	Check room eliminate acid source, replace component using <a href="#">DISASSEMBLY</a> and <a href="#">ASSEMBLY</a>  Replace component using <a href="#">DISASSEMBLY</a> and <a href="#">ASSEMBLY</a>  Replace component using <a href="#">DISASSEMBLY</a> and <a href="#">ASSEMBLY</a>
(5) Battery case and cover damage; dents, deformations, and visible cracks which affect fit or impede performance.	(a) Various, transport (b) Mechanical stress, drop	Replace component using <a href="#">DISASSEMBLY</a> and <a href="#">ASSEMBLY</a>

Physical Faults  
Table 1008



COMPONENT MAINTENANCE MANUAL  
43B050KB01 / 43B050KB02

PAGE INTENTIONALLY LEFT BLANK

**24-30-11**

1018  
Mar 25/2022



COMPONENT MAINTENANCE MANUAL  
43B050KB01 / 43B050KB02

**DISASSEMBLY**

1. General

This section provides step-by-step instructions on disassembling the complete battery.

**NOTE:** The ( ) part identification numbers herein are [IPL Figure 1](#) item numbers.

2. Detailed Instructions

**WARNING:** BATTERY CELLS DELIVER VERY HIGH CURRENTS WHEN SHORT-CIRCUITED. EXERCISE CAUTION. REMOVE RINGS, WATCHES OR OTHER JEWELRY FROM HANDS AND ARMS.

**WARNING:** BATTERY MUST BE COMPLETELY DISCHARGED BEFORE CELL ASSEMBLIES CAN BE REMOVED DUE TO POSSIBILITY OF ELECTRIC SHOCK.

**WARNING:** USE CARE NOT TO TILT BATTERY WHILE VENT VALVES ARE LOOSENED; CONTACT OF ELECTROLYTE WITH SKIN CAN CAUSE SEVERE BURNS.

- A. Discharge the battery at one of the current rates shown in [Table 1005](#) until each cell reaches 1.0V.
- B. Remove cover ([050](#)) by opening latches and lifting cover from case ([010](#) or [010A](#)).
- C. Do [Cell shorting](#)
- D. Cell ([240](#)) removal
  - (1) Remove screws ([160](#)), ([270](#)), lock washers ([170](#)), ([280](#)), and washers ([180](#)), ([290](#)) from terminals of cells ([240](#)) and the power connector ([130](#)).
  - (2) Remove intercell terminal links ([300](#) through [320](#)) from terminals of cells ([240](#)).
  - (3) Using [T04](#) remove cells ([240](#)) and dummy cell ([230](#) or [230A](#)) from the battery case ([010](#) or [010A](#)) by tightening [T04](#) into cell terminals and removing cell with a steady straight up pull.
- E. Power connector ([130](#)) removal
  - (1) Remove the attaching hardware screw ([200](#)), locking washer ([210](#)), and washer ([220](#)) from power connector ([130](#)).
  - (2) Remove screws ([150](#)), power connector ([130](#)), and power connector O-ring ([140](#)) from the battery case ([010](#) or [010A](#)).
- F. Foam fillers ([060](#) through [110](#)) or ([350](#) through [400](#)) and sensor harness ([190](#)) or ([340](#)).
  - (1) Remove foam fillers ([060](#) or [350](#)), ([080](#) or [370](#)), ([110](#) or [400](#)) from battery case ([010](#) or [010A](#)).
  - (2) Remove foam filler ([090](#) or [380](#)) by pushing it downward and then grasping the foam filler ([090](#) or [380](#)) at the bottom and removing from the left or right side through the gap between the bottom of the partition and the battery case ([010](#) or [010A](#)).



## COMPONENT MAINTENANCE MANUAL

43B050KB01 / 43B050KB02

- (3) Remove foam filler ([070](#) or [360](#)) from battery case ([010](#) or [010A](#)).
  - (4) Remove nut ([192](#)) and washer ([196](#)) from the sensor harness ([190](#) or [340](#)) connector and pull from case hole with gasket ([194](#)).
  - (5) Gently remove the temperature sensor unit from its mounting position being careful not to bend out of shape.
  - (6) Slide the sensor wires connected to the sensor harness ([190](#) or [340](#)) connector through the cut out in the battery case partition and remove through the top of the battery case ([010](#) or [010A](#)) to complete the sensor harness ([190](#) or [340](#)) removal.
- G. Remove spacer ([120](#)) from the battery case ([010](#) or [010A](#)).

**24-30-11**

3002  
May 3/2021



COMPONENT MAINTENANCE MANUAL  
43B050KB01 / 43B050KB02

**CLEANING**

1. General

**CAUTION:** DO NOT USE PETROLEUM SPIRITS, TRICHLOROETHYLENE OR OTHER SOLVENTS FOR CLEANING THE BATTERY. USE OF THESE PRODUCTS MAY DETERIORATE THE INTEGRITY OF METAL PARTS.

**NOTE:** The ( ) part identification numbers herein are [IPL Figure 1](#) item numbers.

A. The following items are required for cleaning procedures (equivalent substitutes can be used):

- Stiff bristled brush (nonmetallic)
- Dry compressed air source, less than 1.38 bar (20 psi)
- Safety goggles
- Lubricant, non-acid petroleum jelly, [M02](#)
- Soft, clean cloth (two required)
- Running water
- Mild Soap, [M03](#)
- Distilled or de-ionized water, [M01](#)

2. Light Cleaning

A. The following procedures are for an assembled battery with battery cover ([050](#)) removed.

**CAUTION:** VENT VALVES MUST BE CLOSED TO PREVENT DIRT AND FOREIGN MATTER FROM ENTERING CELLS DURING CLEANING. OVER EXPOSURE TO CO<sub>2</sub> WILL AFFECT BATTERY PERFORMANCE OVER TIME.

B. Using [T01](#) or ([020](#)) make sure that the ¼ turn vent valves ([250](#)) of all cells ([240](#)) are closed and secure. Do not over-tighten.

**CAUTION:** DO NOT USE A WIRE BRUSH TO CLEAN CELL TOPS. CELLS MAY BE DAMAGED.

C. Remove white deposits (potassium carbonate) from tops of all cells ([240](#)) using a stiff bristled nonmetallic brush.

**WARNING:** TO PREVENT INJURY WHEN USING COMPRESSED AIR, DIRECT STREAM AWAY FROM BODY. USE SAFETY GOGGLES TO PREVENT EYE INJURIES FROM FINE DUST PARTICLES.

D. Disperse residual dust and particles from the battery with blasts of clean, dry, compressed air not over 1.38 bar (20 psi).

E. Coat cell screws ([160](#)), ([270](#)), and all intercell terminal links ([300](#) through [320](#)) with a light film of [M02](#). Silicone coatings are not suitable due to the alkaline electrolyte.

F. Clean the exterior surfaces of the battery cover ([050](#)) and battery case ([010](#) or [010A](#)) using a soft, clean cloth, moistened with water. Dry with compressed air or a dry, clean cloth.

**24-30-11**

4001  
Nov 14/2022



COMPONENT MAINTENANCE MANUAL  
43B050KB01 / 43B050KB02

3. Thorough Cleaning

- A. The battery must be discharged (refer to [Initial discharge](#) and [Cell shorting](#)) and disassembled (refer [DISASSEMBLY](#)).
- B. Remove greasy residue from power connector ([130](#)) with warm mild soapy [M03](#) water.
- C. After ensuring that the ¼ turn vent valves ([250](#)) are closed, wash each cell ([240](#)) and dummy cell ([230](#) or [230A](#)) in running water. Do not allow any water to enter the cell. Dry with compressed air or a dry, clean cloth.
- D. Without submerging the connector of sensor harness ([190](#) or [340](#)), wipe clean with damp cloth and let dry.
- E. Wash the battery case ([010](#) or [010A](#)), cover ([050](#)), fillers ([060](#) through [110](#)) or ([350](#) through [400](#)), spacer ([120](#)), O-ring ([140](#)), and hardware ([160](#) through [180](#)), ([200](#) through [220](#)), ([270](#) through [290](#)), and links ([300](#) through [320](#)) in warm mild soapy [M03](#) water to remove dirt and salt deposits. A plastic scraper or a stiff bristled brush (nonmetallic) may be used to aid in the removal of heavy deposits. Rinse away [M03](#), and thoroughly dry with compressed air or a dry, clean cloth.

**NOTE:** Be sure the foam fillers ([060](#) through [110](#)) or ([350](#) through [400](#)) are completely dry.





COMPONENT MAINTENANCE MANUAL  
43B050KB01 / 43B050KB02

**CHECK**

1. General

This section contains battery inspection information. The procedures are written in step-by-step formats that follow the process flow outlined in [Figure 1001](#).

**NOTE:** All voltage readings are DC unless otherwise stated.

**NOTE:** All ( ) part identification numbers herein are [IPL Figure 1](#) item numbers.

2. Initial New Battery Commissioning

A. Before the initial charge, thoroughly inspect the battery assembly to ensure no damage has occurred during shipping or storage as follows:

**NOTE:** For a new battery not receiving its initial commission within one year of its DOM, then battery must follow [Figure 1001](#)

- (1) Inspect the battery case ([010](#) or [010A](#)) and cover ([050](#)) for dents, distortion, or other damage. If found, replace case ([010](#) or [010A](#)) or cover ([050](#)).
- (2) Remove the battery cover ([050](#)).
- (3) Visually confirm the power connector ([130](#)) is present and undamaged.
- (4) Visually confirm all cells ([240](#)) and dummy cell ([230](#) or [230A](#)) are positioned for proper polarity per [Figure 7002](#).
- (5) Visually confirm all cells ([240](#)) and dummy cell ([230](#) or [230A](#)) are equipped with a vent valve ([250](#)).
- (6) Tighten all screws ([160](#)) and ([270](#)) per [Table 8001](#).
- (7) Visually confirm the sensor harness ([340](#)) is present and undamaged.

B. Charge the battery per [Charge](#) on page [1007](#) and level electrolyte per [Electrolyte leveling](#) on page [1009](#).

C. Do successful [Battery insulation](#) test and install battery cover ([050](#)), then the battery is ready for service.

3. Component Inspection

A. Cell ([240](#))

- (1) Visually check for evidence of electrolyte leakage, cracks, corrosion, burns, holes, or damaged terminal treads. Replace any defect cells ([240](#)) and dummy cell ([230](#) or [230A](#)) with new Saft cells ([240](#)) or dummy cell ([230](#) or [230A](#)).
- (2) Visually check each cell vent valve ([250](#)) for defective O-rings ([260](#)) cracks, or other physical damage. Replace defective O-rings ([260](#)).
  - (a) Suspect vent valves should be tested in accordance with [Vent valve tests](#) on page [1008](#) and/or be discarded, if necessary.



COMPONENT MAINTENANCE MANUAL  
43B050KB01 / 43B050KB02

- B. Intercell terminal links ([300](#) through [320](#)) inspect for bends, tarnish, loss of nickel plating, corrosion, or burns. Tarnish can be polished off with a fine wire brush. Replace any defective intercell links.
- C. Foam fillers ([060](#) through [110](#)) or ([350](#) through [400](#)) and spacer ([120](#)) inspect contamination and free of cracks or holes. Replace any that are defective.
- D. Power connector ([130](#))

**CAUTION:** A DEFECTIVE POWER CONNECTOR CAN CAUSE DANGEROUS OVERHEATING AND IN-SERVICE LOW VOLTAGE DURING DISCHARGE.

- (1) Check the power connector ([130](#)) for evidence of arching, corrosion, cracks, or cross threaded terminals.
  - (2) Using the same methods in [Battery insulation](#) check on page [1004](#), check the insulation between the positive pin and the connector shell and the negative pin and connector shell.
  - (3) Discard any power connector ([130](#)) that is found to have any damage or fails the insulation test and replace with new Saft battery power connector ([130](#)).
- E. Sensor harness ([190](#) or [340](#))
- (1) Inspect electrical connector for bent or loose pins, corrosion, cracks, faulty wire connections, and evidence of arcing.
  - (2) Visually check all wiring damage to insulation, cracked or broken wire, and other physical defects
  - (3) Inspect charge control thermistor and thermostat for damage, loose or broken wire connections, cracks, dents, or other physical defects.
  - (4) Any evidence of the above conditions, however minor, is grounds for rejection. Discard the damaged unit and replace with factory new.
- NOTE:** Sensor harness ([190](#)) and ([340](#)) are non-repairable items and should be replaced if defective. The sensor harness is to be replaced with ([340](#)).
- F. Battery cover ([050](#)) and case ([010](#) or [010A](#))  
Inspect the components for damage. If found, replace with new Saft cover ([050](#)) or case ([010](#) or [010A](#)) as needed.



COMPONENT MAINTENANCE MANUAL  
43B050KB01 / 43B050KB02

**REPAIR**

1. General

This section contains basic battery component procedures.

**NOTE:** The ( ) part identification numbers herein are [IPL Figure 1](#) item numbers.

**NOTE:** All voltage readings are DC unless otherwise stated.

2. Required Test Equipment)

**NOTE:** Test equipment with equivalent specifications can be used.

Refer to [Special Tools, Fixtures, Equipment, and Consumables](#) for listing of Standard Tools.

3. Component Replacement

A. Cell replacement

A battery containing cell(s) ([240](#)) require replacement. Note the [All cell replacement](#) recommendation below.

(1) All cell replacement

(a) For a battery compliant with the following, it is best to assume that all the original cells are or soon will be in unsatisfactory condition. Saft strongly recommends all cells ([240](#)) should be replaced with new Saft cells for a battery having:

1 3 or more faulty cells are replaced during the same maintenance interval.

Or

2 1 or more cells are found to be faulty during this maintenance period and 5 of the original cells in the battery have been previously replaced due faults.

**NOTE:** The recommendation does not apply to the following failures: terminal thread damage, cell leakage, or cell short-circuit

(2) Do [DISASSEMBLY](#) and [ASSEMBLY](#) to replace cells.

B. Cell hardware replacement

(1) Replace as necessary washers ([180](#)), ([290](#)), lock washers ([170](#)), ([280](#)), and screws ([160](#)), ([270](#)) by removing screws ([160](#)), ([270](#)). Torque screws ([160](#)), ([270](#)) per [Table 8001](#).

**NOTE:** Do not attempt further disassembly of the cell subassembly as cells are non-repairable items and must be replaced as a unit if defective.

**24-30-11**

6001

May 15/2023



COMPONENT MAINTENANCE MANUAL  
43B050KB01 / 43B050KB02

PAGE INTENTIONALLY LEFT BLANK

**24-30-11**

6002  
Mar 25/2022

## ASSEMBLY

### 1. General

This section contains assembly step-by-step instructions.

**NOTE:** Make sure all components are clean and dry before re-assembly.

**NOTE:** All ( ) part identification numbers herein are [IPL Figure 1](#) item numbers.

### 2. Components

Refer to [Figure 7001](#) for installation.

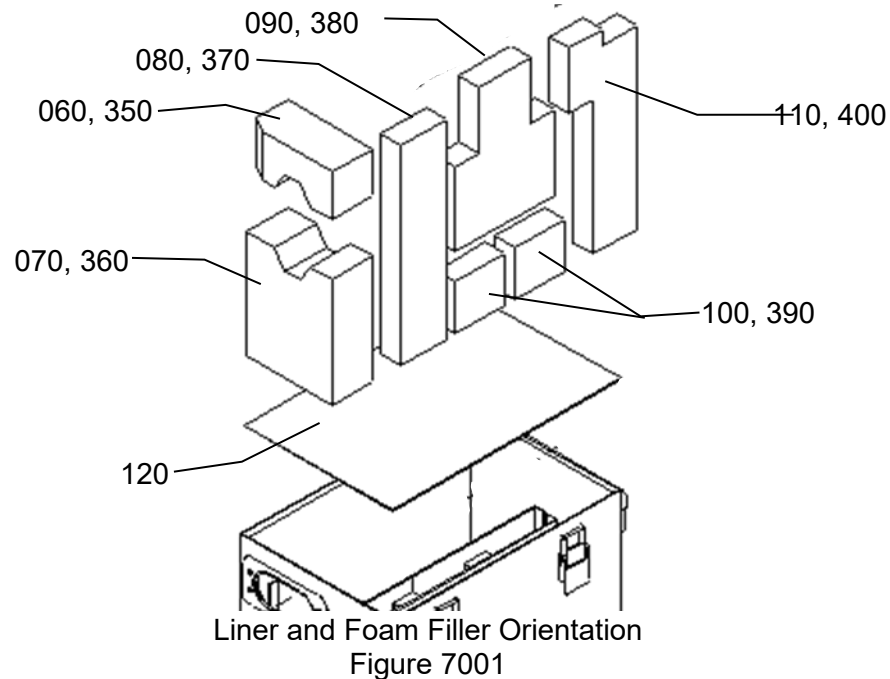

- A. Insert one edge of bottom liner ([120](#)) into battery case ([010](#) or [010A](#)) from either the left or right side, then slide the liner under the cell partition.
- B. Insert foam filler ([100](#) or [390](#)), 2 each, into battery case ([010](#) or [010A](#)).
- C. Insert sensor harness ([190](#) or [340](#)) with gasket ([194](#)) into battery case ([010](#) or [010A](#)). Ensure that the sensor plate is on the outside of the partitions of the battery case and the dimples on the sensor plate mate with the holes in the battery case partitions.
- D. Insert foam filler ([070](#) or [360](#)) into battery case ([010](#) or [010A](#)).
- E. Insert sensor harness ([190](#) or [340](#)) connector through hole in battery case ([010](#) or [010A](#)). Ensure that the two wire leads from the sensor plate are placed in the indentation of foam filler ([070](#) or [360](#)) and the third wire lead of the sensor harness that has the compression lug attached is free.
  - (1) Install washer ([194](#)) and nut ([192](#)) onto the sensor harness ([190](#) or [340](#)) connector. Torque nut ([192](#)) per [Table 8001](#).

## COMPONENT MAINTENANCE MANUAL 43B050KB01 / 43B050KB02

- F. Insert foam filler ([090](#) or [380](#)) in between center partition of battery case ([010](#) or [010A](#)) from the below the partition and pushing upward.
- G. Insert the remaining foam fillers ([060](#) or [350](#)), ([110](#) or [400](#)), ([080](#) or [370](#)) into battery case ([010](#) or [010A](#)).
- H. Insert power connector ([130](#)) with gasket ([140](#)) attached. Insert screws ([150](#)) and torque per [Table 8001](#).
  - (1) Insert the remaining wire from the sensor harness ([190](#) or [340](#)) to the power connector ([130](#)) using washer ([210](#)), lock washer ([220](#)) and pan head screw ([200](#)). Torque pan head screw ([200](#)) per [Table 8001](#).
- I. Cells ([240](#)) and Dummy Cell ([230](#) or [230A](#))
  - (1) Install dummy cell ([230](#) or [230A](#)) in position 1 the battery case ([010](#) or [010A](#)) directly to the right of the power connector ([130](#)) making sure of correct polarity. Refer to [Figure 7002](#).
  - (2) Install cells ([240](#)) as shown in [Figure 7002](#).

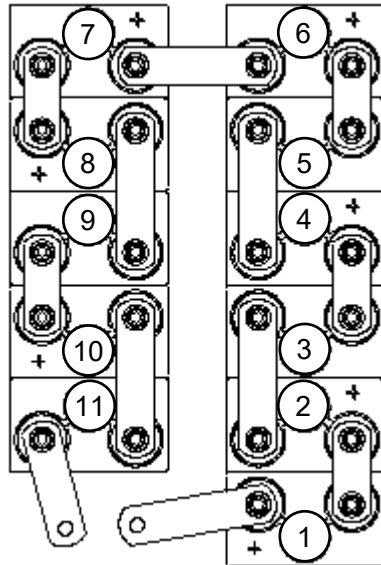

Cell Number and Polarity Orientation  
Figure 7002

### 3. Complete Battery

- A. Install intercell links ([300](#)), ([310](#)), ([320](#))
- B. Install washer ([180](#)), ([290](#)), lock washer ([170](#)), ([280](#)), and screws ([160](#)), ([270](#)). Torque screws ([160](#)), ([270](#)) per [Table 8001](#).
- C. Apply a small amount of [M02](#) to the hardware ([160](#)), ([170](#)), ([180](#)), ([270](#)), ([280](#)), ([290](#)), and links ([300](#) through [320](#)). Install intercell terminal links ([300](#) through [320](#)) on the terminals of the cells ([240](#)) and power connector ([130](#)) as shown in [Figure 7002](#).
- D. Install the battery cover ([050](#)) onto the battery case ([010](#) or [010A](#)) and secure in place by fastening the latches.



COMPONENT MAINTENANCE MANUAL  
43B050KB01 / 43B050KB02

**FITS AND CLEARANCES**

1. Torque Table

IPL FIGURE	ITEM NUMBER	TORQUE VALUE		NAME, LOCATION
		Nm	lb <sub>f</sub> -in	
1	<a href="#">160, 270</a>	9.9 ± 1.0	88 ± 9	Screw, Socket Head
1	<a href="#">200</a>	1.1 ± 0.1	10 ± 1	Screw
1	<a href="#">150</a>	2.3 ± 0.2	20 ± 2	Screw, Sems
1	<a href="#">196</a>	7.1 ± 0.7	63 ± 6	Nut Aux. Connector Mounting
1	<a href="#">030</a>	0.20 ± 0.06	2.0 ± 0.5	Screw

Torque Values  
Table 8001

2. Fits and Clearances Table

No fits and clearances required.



COMPONENT MAINTENANCE MANUAL  
43B050KB01 / 43B050KB02

PAGE INTENTIONALLY LEFT BLANK

**24-30-11**

8002  
Mar 25/2022





COMPONENT MAINTENANCE MANUAL  
43B050KB01 / 43B050KB02

**SPECIAL TOOLS, FIXTURES, EQUIPMENT, AND CONSUMABLES**

1. Special Tools

A. Battery maintenance kit

**NOTE:** Equivalent tools can be used.

**NOTE:** A special tool kit (P/N 023249-000) is available from Saft containing special tools T01, T02, and T04. The kit also includes 22 replacement vent valve O-rings ([260](#)), T06.

ITEM	DESCRIPTION	09052 P/N	F6177 P/N
T01	Vent valve wrench	004414-000	-
T02	Indicator Level, Electrolyte (To be modified by customer per <a href="#">Figure 1003</a> )	021961-000	-
T03	1.2Ω 3W equalizing resistors	-	164829
T04	Cell extraction tool	026745-000	-
T05	Vent Valve adapter for MS valves	024398-000	-
T06	O-rings ( <a href="#">260</a> ) – Qty 22	012536-002	-

Special Tools  
Table 9001

2. Standard Tools

A. The following items are recommended to do the procedures described in this manual. When necessary equivalent substitutes may be used.

- Constant current charger (DC current range 0 – 60A, minimum open DC voltage 40V)
- Constant current load bank (DC current range 0 – 60 A, DC voltage range 1 – 40V)
- Megohmmeter (0 – 50 MΩ @ 250 V DC continuous)
- Precision Multimeter (Volt, Ω, mA) 2000 count, accuracy 1% or better
- Torque Wrench (Insulated) 0 to 15 N-m (0 to 133 lb<sub>r</sub>-in)
- Torque Screwdriver 0 to 3.4 N-m (0 to 30 lb<sub>r</sub>-in)
- Thermometer, Immersion, Fisher Scientific Catalog # 14-990-B
- Standard mechanic's tools.
- Safety gloves.
- Protective goggles.
- Safety shoes.
- Eye wash.
- Protective apron.
- Stiff bristle brush (non-metallic)
- Small paintbrush (non-metallic)
- Dry, compressed air source [less than 1.38 bar (20 psi)]
- Soft, clean cloth (at least two required)

**24-30-11**

9001  
Nov 14/2022



COMPONENT MAINTENANCE MANUAL  
43B050KB01 / 43B050KB02

3. Consumables

This paragraph describes the consumables used in the CMM.

**NOTE:** Equivalent alternatives can be used for list items.

ITEM	DESIGNATION PART NUMBER AND SPECIFICATION DESCRIPTION	MANUFACTURER OR SUPPLIER (NAME, ADDRESS, CODE)
M01	Distilled or deionized water @ +20°C ± 5°C (+68°F ± 9°F): Clear, colorless, and odorless while boiling Conductivity < 33 µS/cm 5 < pH < 7 Mn-COD < 30 mg/l (1.7 x 10 <sup>-5</sup> oz/in <sup>3</sup> ) (Chemical Oxygen Demand, methodology to evaluate organic or mineral pollution) Chlorines Cl <sup>-</sup> < 5 mg/l (2.9 x 10 <sup>-6</sup> oz/in <sup>3</sup> ) Sulfates SO <sub>4</sub> <sup>2-</sup> < 10 mg/l (5.8 x 10 <sup>-6</sup> oz/in <sup>3</sup> )  STORAGE: dry and clean container without any corrosion and damage; Temperature: +20°C ± 5°C (+68°F ± 9°F). Over 1 year of storage, do an analysis of the liquid.	Local Vendor
M02	Neutral petroleum jelly Density @ +60°C (+140°F) Range = 0.840 to 0.866 kg/l (0.486 to 0.501 oz/in <sup>3</sup> ) Melting Point Range = +46°C to +52°C (+115°F to +126°F) Acidity/Alkalinity = Neutral to Litmus	Mineral Vaseline NATO: S 743 F: AIR 3565 US: VV-P-236A UK: DEF 2333
M03	Mild Soap	Local Vendor

Consumables  
Table 9002

**24-30-11**

9002  
Mar 25/2022



COMPONENT MAINTENANCE MANUAL  
43B050KB01 / 43B050KB02

**ILLUSTRATED PARTS LIST**

1. Introduction

A. Purpose

- (1) This section provides illustrations and parts breakdown of the batteries, which can be disassembled, replaced, and reassembled.

B. Explanation and usage of section

- (1) Assembly order indenture system

The Indenture System used in the parts list shows the relationship of one part to another. For a given item, the number of indentures depicts the relationship of the item to the associated next higher assembly.

- (2) Effectively code

Reference letters (A, B, C, etc.) are assigned in the EFF CODE column to each top assembly. The reference letter of the applicable top assembly is also shown in the EFF CODE column for each detail part and subassembly except that no reference letter is shown for detail parts and subassemblies used on all top assemblies.

- (3) Quantity per assembly

The UNITS PER ASSY column shows the total number of units required per assembly, per subassembly, and per sub-subassembly as applicable. The letters REF indicates the item is listed for reference purposes.

- (4) Parts replacement data

Interchangeability information will be provided in a future manual revision if it becomes applicable.

- (5) Service Bulletin incorporation

Service Bulletin incorporation information applicable to the parts list will be provided in a future manual revision if it becomes applicable.

- (6) Items not illustrated

Items not illustrated are indicated by a dash ( - ) ahead of the item numbers in the Fig. and Index column.

**24-30-11**

10001  
Mar 25/2022



COMPONENT MAINTENANCE MANUAL  
43B050KB01 / 43B050KB02

- (7) Alpha variant item numbers
  - (a) Alpha variants A – Z (except I and O) are assigned to existing item numbers when necessary to show:
    - 1 Added items
    - 2 Service Bulletin modifications
    - 3 Configuration differences
    - 4 Optional parts
    - 5 Product improvement parts (non-service bulletin)
  - (b) Alpha variant item numbers are not shown on the exploded view when the appearance and location of the alpha variant item is the same as the basic item.

(8) Vendors

The vendor of all parts shown in the parts list is as follows:

CAGE Code	NAME / ADDRESS	CAGE Code	NAME / ADDRESS
<b>09052</b>	Saft America Inc. 711 Gil Harbin Industrial Boulevard Valdosta, GA 31601 USA Phone: +1 (229) 247-2331 Fax: +1 (229) 247-8486	<b>F6177</b>	Saft 126 quai Charles Pasqua 92300 Levallois-Perret France Phone: +33 1 58 63 16 00 Fax: +33 1 58 63 16 18

[www.saft.com](http://www.saft.com)

**24-30-11**

10002  
May 15/2023



COMPONENT MAINTENANCE MANUAL  
43B050KB01 / 43B050KB02

2. Numeric Index

PART NUMBER	AIRLINE STOCK NUMBER	FIGURE NUMBER	ITEM NUMBER	UNIT	UNITS PER ASSY
MS3186C109P			192		1
MS35338-136			220		1
004414-001			020		1
012536-002			260		10
013357-049			120		1
021930-000			240		10
021931-000		1	-		RF
021985-000			070 or 360		1
022001-000			300		5
022002-000			310		5
022003-000			320		2
022012-000			130		1
022026-000			110		1
022037-000			080		1
022043-000			050		1
022105-000			030		1
022121-000			010		1
022172-000			100		2
022173-000			090		1
022221-000			250		10
022271-000			060 or 350		1
022275-000			230		1
022281-000			196		1
022290-000			194		1
024051-000		1	-		RF
024058-000			230A		1
024059-000			010A		1
026709-000			340		1
026710-000			390		2
026711-000			380		1
026712-000			370		1
026713-000			400		1
092456-000			170, 280		24
092461-005			210		1
092488-000			180, 290		24
093015-003			200		1

**24-30-11**

10003  
Mar 25/2022



COMPONENT MAINTENANCE MANUAL  
43B050KB01 / 43B050KB02

<b>PART NUMBER</b>	<b>AIRLINE STOCK NUMBER</b>	<b>FIGURE NUMBER</b>	<b>ITEM NUMBER</b>	<b>UNIT</b>	<b>UNITS PER ASSY</b>
093422-000			140		1
093616-000			150		4
093704-000			040		1
093707-002			160, 270		24

**24-30-11**

10004  
May 3/2021

## COMPONENT MAINTENANCE MANUAL 43B050KB01 / 43B050KB02

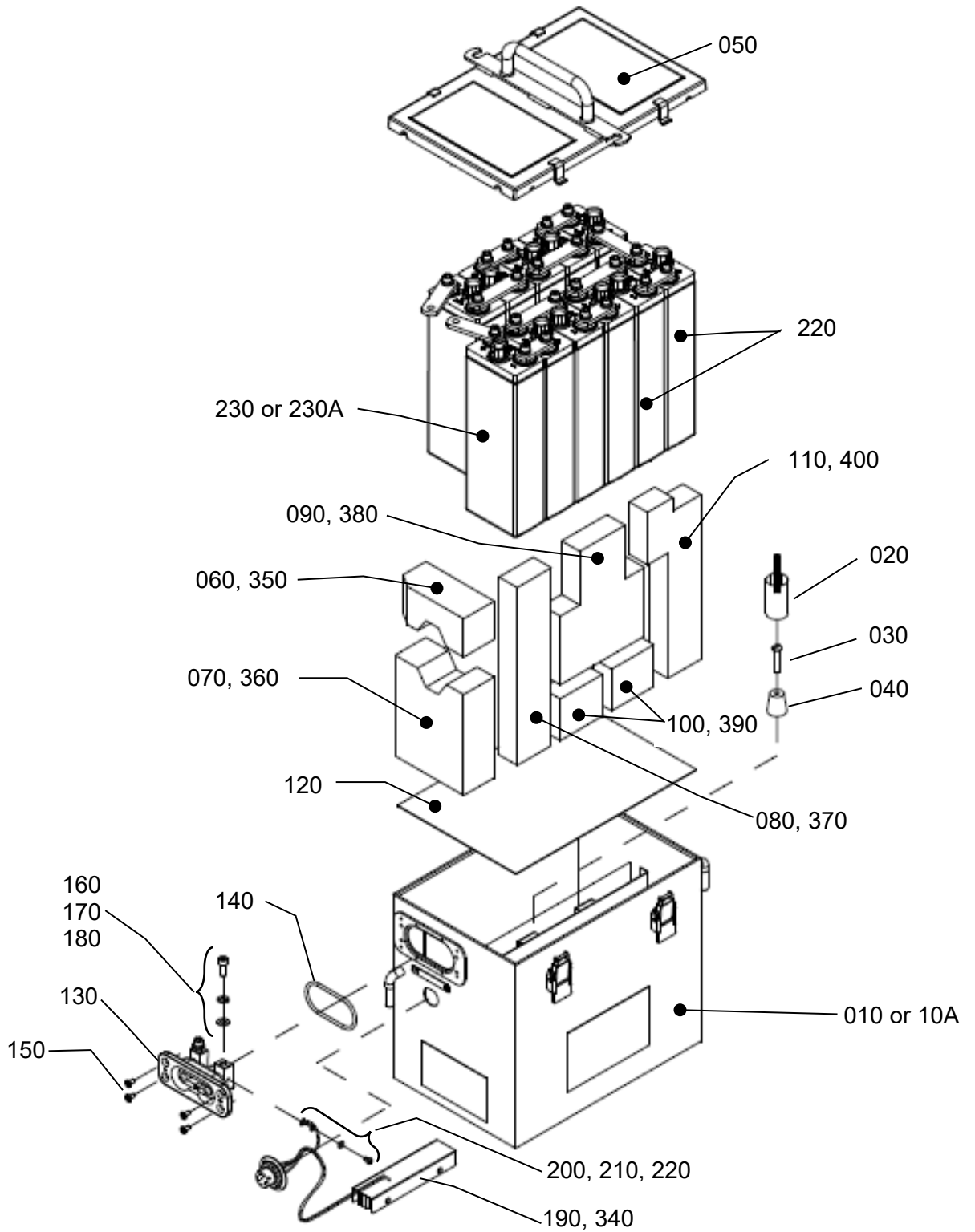

Battery, Exploded View  
IPL Figure 1 (#1 of 4)

**24-30-11**

10005  
Nov 14/2022

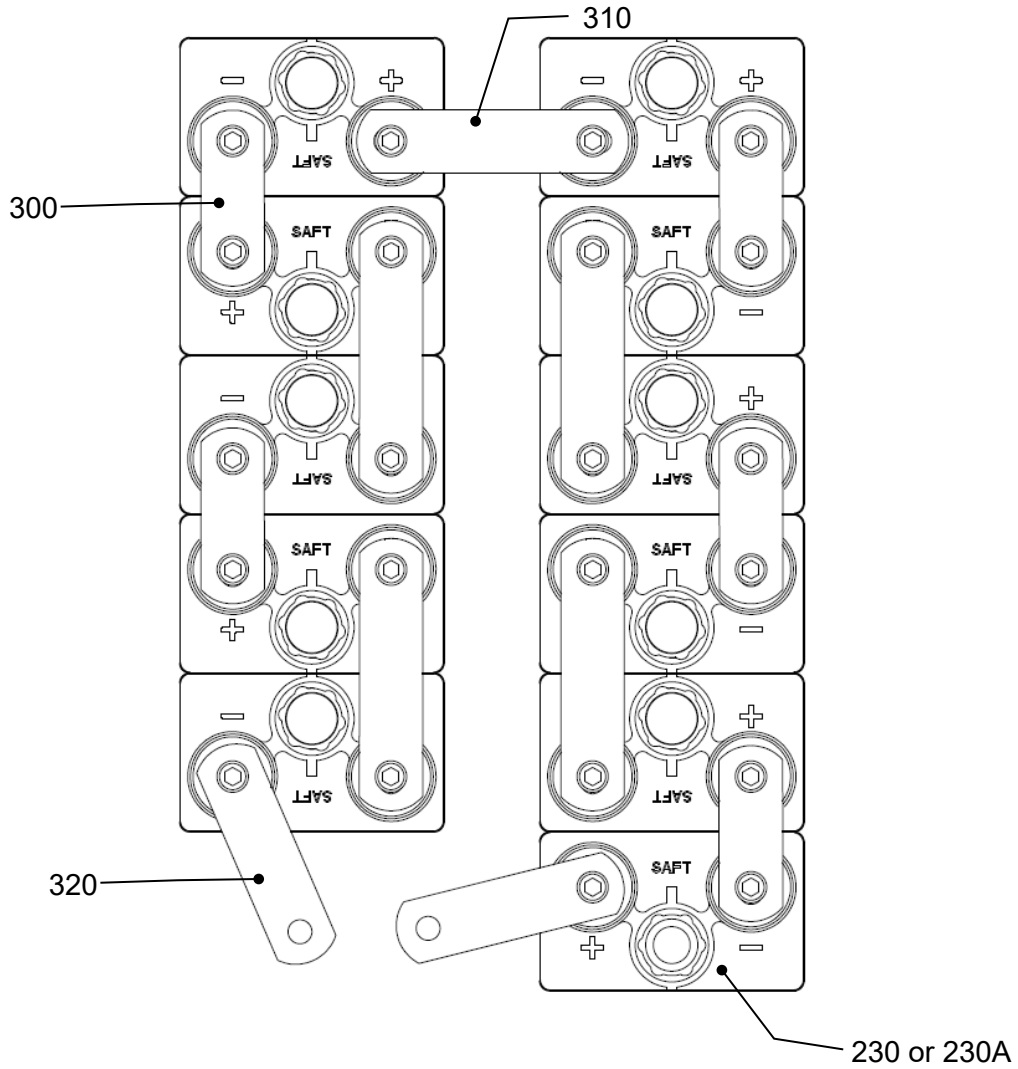

Battery, Exploded View  
IPL Figure 1 (#2 of 4)



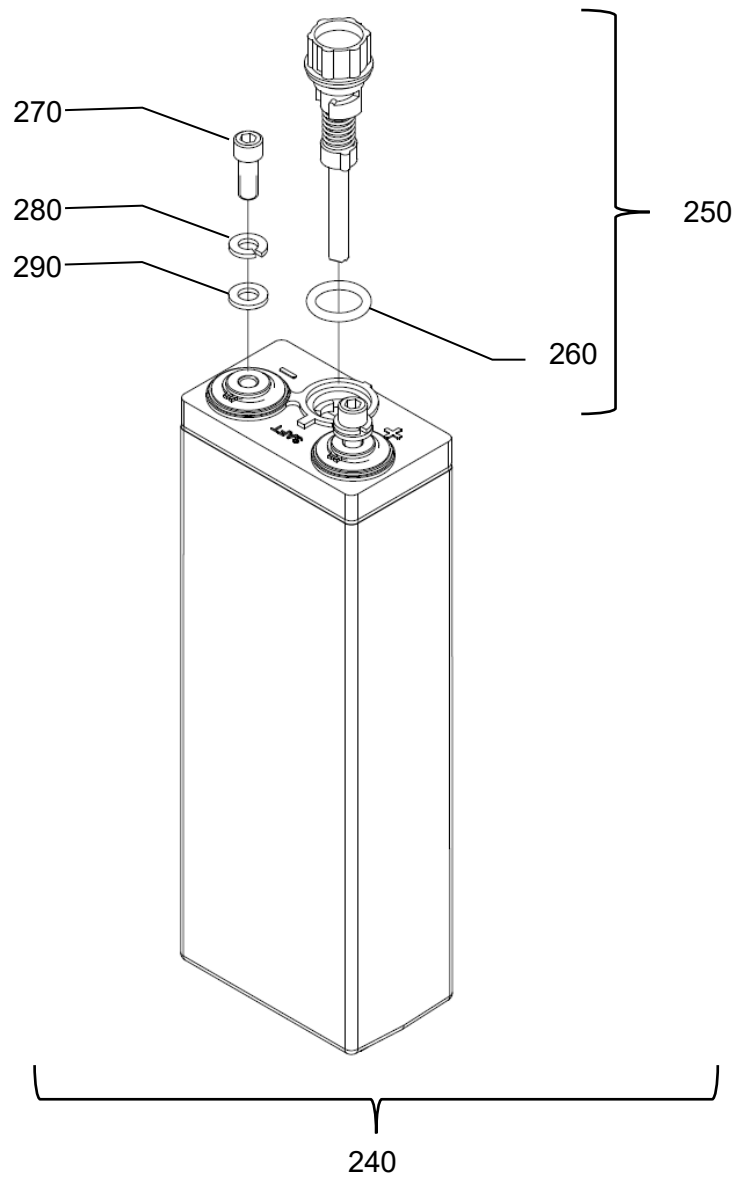

Battery, Exploded View  
IPL Figure 1 (#3 of 4)

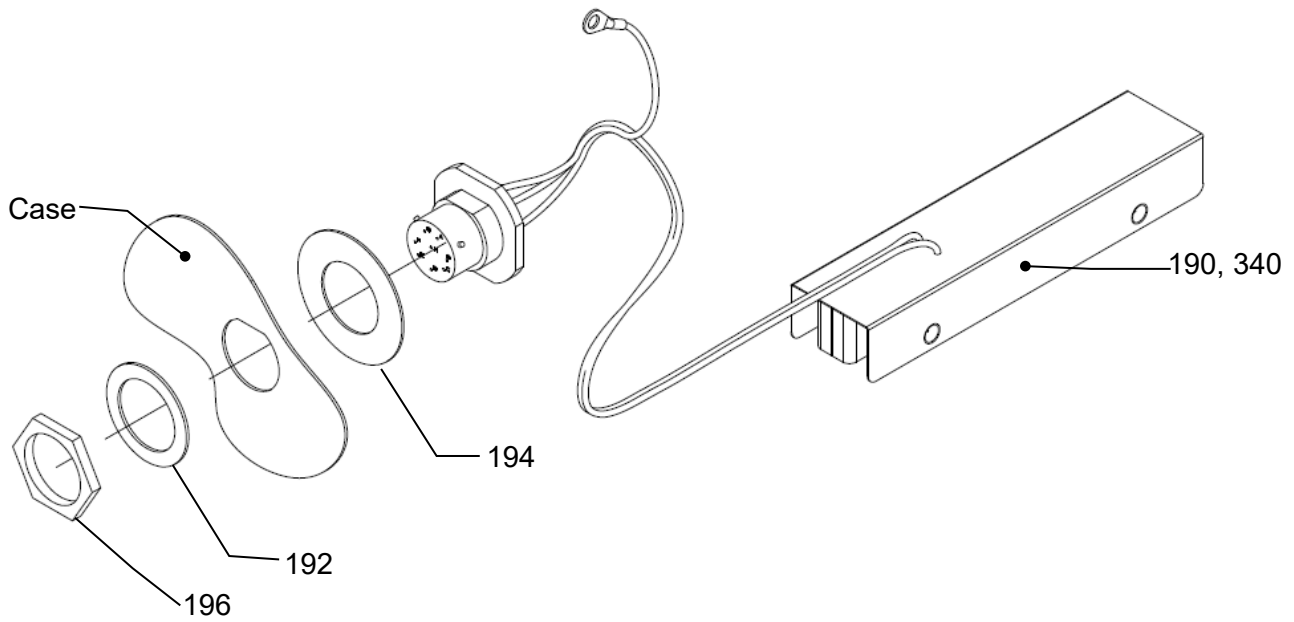

Battery, Exploded View  
IPL Figure 1 (#4 of 4)



COMPONENT MAINTENANCE MANUAL  
43B050KB01 / 43B050KB02

3. Details Parts List

FIG. & ITEM NUMBER	PART NUMBER	AIRLINE PART NO.	NOMENCLATURE 1234567 .....	EFF CODE	UNITS PER ASSY
1 -1	021931-000		<b>Nickel Cadmium Battery, 43B050KB01</b>	A	RF
-1A	021931-000		<b>Nickel Cadmium Battery, 43B050KB01</b>	B	RF
-1B	024051-000		<b>Nickel Cadmium Battery, 43B050KB02</b>	C	RF
-1C	024051-000		<b>Nickel Cadmium Battery, 43B050KB02</b>	D	RF
010	022121-000		. Case Marked	A, B	1
010A	024059-000		. Case Marked	C, D	1
020	004414-001		. Wrench, Vent Cap		1
030	022105-000		. Screw, Truss Head		1
040	093704-000		. Stopper, Rubber		1
050	022043-000		. Cover Assembly		1
060	022271-000		. Foam Filler	A, C	1
070	021985-000		. Foam Filler	A, C	1
080	022037-000		. Foam Filler	A, C	1
090	022173-000		. Foam Filler	A, C	1
100	022172-000		. Foam Filler	A, C	2
110	022026-000		. Foam Filler	A, C	1
120	013357-049		. Liner Bottom		1
130	022012-000		. Connector, Power		1
140	093422-000		. O-ring		1
150	093616-000		. Screw, Sems		4
160	093707-002		. Screw, Socket Head		2
170	092456-000		. Washer, Lock		2
180	092488-000		. Washer		2
190	022036-000		. Harness, Sensor REPLACED BY ITEM <a href="#">330</a>	A, C	1
192	MS3186C109P		. . Nut		1
194	022290-000		. . Gasket		1
196	022281-000		. Washer		1
200	093015-003		. Screw, Pan Head		1
210	092461-005		. Washer		1
220	MS35338-136		. Washer, Lock 09052 P/N 092375-000		1
230	022275-000		. Dummy Cell	A, B	1
230A	024058-000		. Dummy Cell	C, D	1
240	021930-000		. Cell, 43B050AC01-2		10
250	022221-000		. . Valve, Vent		1
260	012536-002		. . . O-ring		1
270	093707-002		. Screw, Socket Head		22

DASH (-) ITEM NOT ILLUSTRATED

**24-30-11**

10009  
Nov 14/2022



COMPONENT MAINTENANCE MANUAL  
43B050KB01 / 43B050KB02

FIG. & ITEM NUMBER	PART NUMBER	AIRLINE PART NO.	NOMENCLATURE 1234567 .....	EFF CODE	UNITS PER ASSY
280	092456-000		. Washer, Lock		22
290	092488-000		. Washer		22
300	022001-000		. Link		5
310	022002-000		. Link		5
320	022003-000		. Link		2
-330	026714-000		. Kit, Sensor Harness & Filler Blocks	B, D	1
340	026709-000		. . Harness, Sensor REPLACES ITEM <a href="#">190</a>	B, D	1
350	022271-000		. . Foam Filler	B, D	1
360	021985-000		. . Foam Filler	B, D	1
370	026712-000		. . Foam Filler	B, D	1
380	026711-000		. . Foam Filler	B, D	1
390	026710-000		. . Foam Filler	B, D	2
400	026713-000		. . Foam Filler	B, D	1

DASH (-) ITEM NOT ILLUSTRATED

**24-30-11**

10010  
May 15/2023



COMPONENT MAINTENANCE MANUAL  
43B050KB01 / 43B050KB02

**STORAGE (INCLUDING TRANSPORTATION)**

1. Introduction

- A. Storage preparation and packaging makes sure that the equipment is protected against any attack by atmospheric agents.
- B. For a battery which has been cleaned and serviced and is not directly put into service on board an aircraft, different methods can be recommended depending on the purpose and the environment conditions of the “storage”.
- C. Keep the batteries and spares in a dry and clean room.

2. Inactive Long-Term Storage

A. Procedure

(1) The following must be done to any battery with prior service history.

(a) [Charge](#), [Electrolyte level](#), [Vent valve test](#), and [Capacity test](#).

**NOTE:** It is not necessary that it be short circuited. There is no need of maintenance operation during the storage period.

**NOTE:** The standard cardboard packaging is considered unsealed and allows 2 years of storage. Storage is allowed for 10 years if the following conditions are met: sealed packaging and isolated from harmful agents (i.e.: dirt, dust, vibrations, or corrosive atmosphere).

- sealed packaging,
- temperature: +5°C to +35°C (+41°F to +95°F),
- humidity < 90%,
- normal vertical position,
- Isolated from detrimental agents: i.e., dirt, dust, dampness, vibration, corrosive atmosphere.

(2) Saft Ni-Cd batteries may be stored in temperatures ranging from -55°C to +5°C or +35°C to +60°C (-67°F to +41°F or +95°F to +140°F) for an accumulated exposure that does not exceed 30 days.

(3) Lead batteries must not be stored in the same room.

B. Servicing at end of long-term storage

STORAGE TIME	SERVICE PROCEDURE
Less than or equal to 12 months	Do <a href="#">Visual Inspection</a> and return to <a href="#">Figure 1001</a> entry point “ <a href="#">C</a> ”
More than 12 months	Do <a href="#">Charge</a> and return to <a href="#">Figure 1001</a> entry point “ <a href="#">Received</a> ”

Return to Service Following Storage  
Table 15001

### 3. Inactive Standby Storage

The battery is charged after being serviced then stored fully charged in a dedicated room in such a way that it can be installed in the aircraft without further maintenance except as provided within this section. Refer to [Figure 15002](#).

**NOTE:** At any time during the inactive standby storage shown in [Figure 15002](#), the battery may be installed on the aircraft or placed into [Inactive Long-Term Storage](#).

**NOTE:** For a battery previously stored at a temperature below ambient temperature, condensation within the battery may occur, do [Battery insulation](#) before installation.

A. Standby period is the rest time that corresponds to 80% available capacity shown in [Figure 15001](#), (example, 24 days at +30°C (+86°F)).

**NOTE:** The maximum time for the standby period is 90 days for temperatures ≤ +23°C (+73°F).

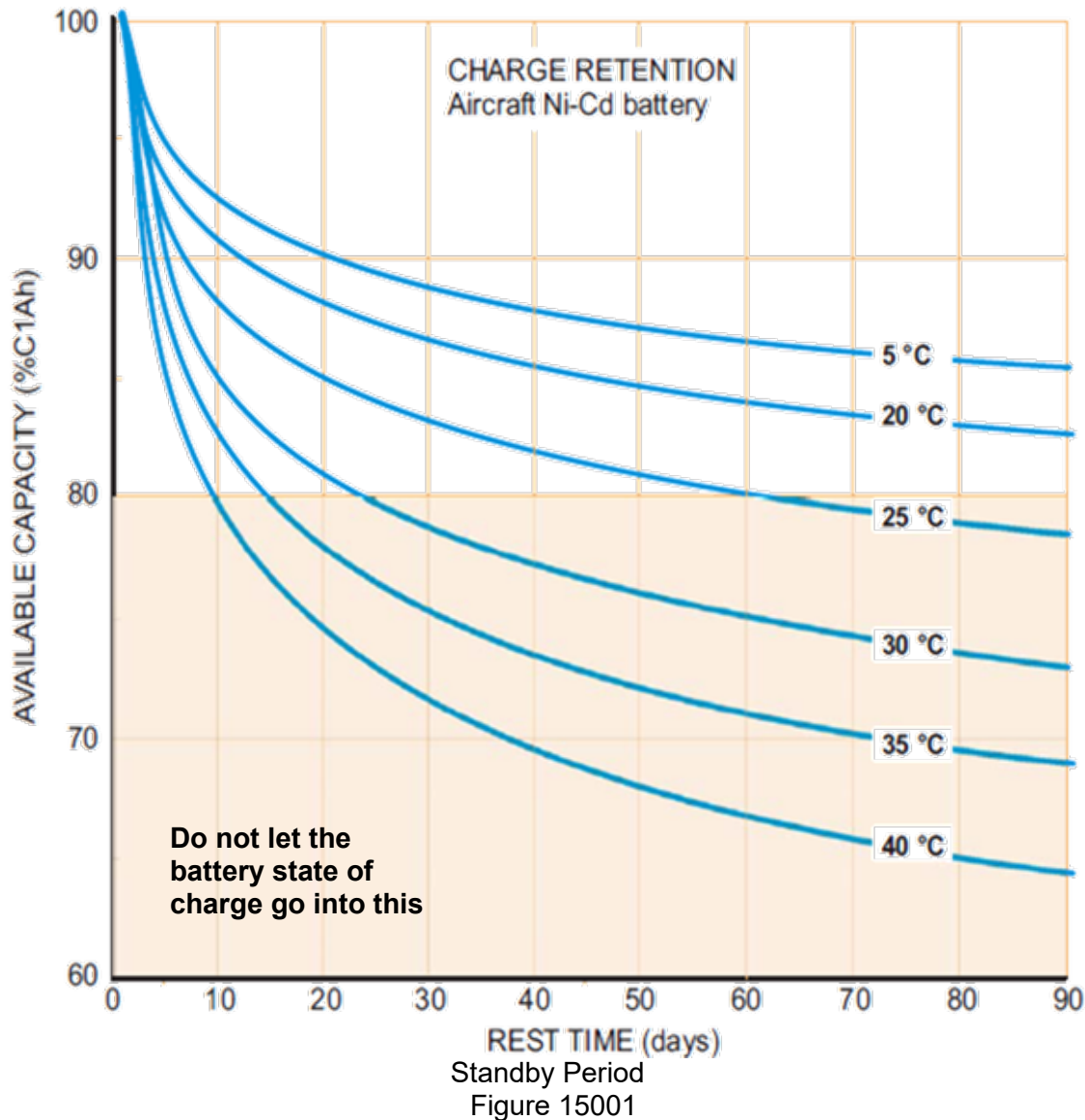

## COMPONENT MAINTENANCE MANUAL 43B050KB01 / 43B050KB02

- B. Refresh charge is a quick constant current charge that can be done at the end of a [Standby period](#) to extend the time the battery is in inactive standby storage. The charge is given in the [Table 15002](#).

**CAUTION:** DO NOT DO THE 4 HOURS FINAL CHARGE AT 0.1 C<sub>1</sub>A (REFER TO [CHARGE](#)) DURING THIS 'REFRESH' CHARGE OPERATION.

CHARGE RATE	VOLTAGE (END OF "REFRESH" CHARGE)
0.1C <sub>1</sub> A	15.0V for 10 Cells
0.5C <sub>1</sub> A	15.5V for 10 Cells
1.0C <sub>1</sub> A	15.7V for 10 Cells

Refresh Charge  
Table 15002

- C. Standby duration consists of a maximum of 3 standby periods with 2 refresh charges. The number of consecutive standby durations is limited to 3. Refer to [Figure 15002](#).
- (1) For a battery completing the first or second standby duration and not immediately installed in the aircraft or sent into long-term storage, do the one of the following:
    - (a) For environments ≤ +30°C (+86°F) do [Battery insulation](#), [Initial discharge](#), [Charge](#), [Electrolyte level](#), and [Battery insulation](#).
    - (b) For environments > +30°C (+86°F) do [Battery insulation](#), [Initial discharge](#), [Cell shorting](#), [Charge](#), [Electrolyte level](#), and [Battery insulation](#).
  - (2) For a battery completing the third consecutive standby durations, the battery can go into [Inactive Long-Term Storage](#) or return to [Figure 1001](#).
- D. Inactive standby storage schedule is limited to the [Standby duration](#) being conducted a maximum of 3 times as shown in [Figure 15002](#).

**NOTE:** At any time during this inactive standby storage schedule shown in [Figure 15002](#), the battery may be installed on the aircraft or placed into [Inactive Long-Term Storage](#).

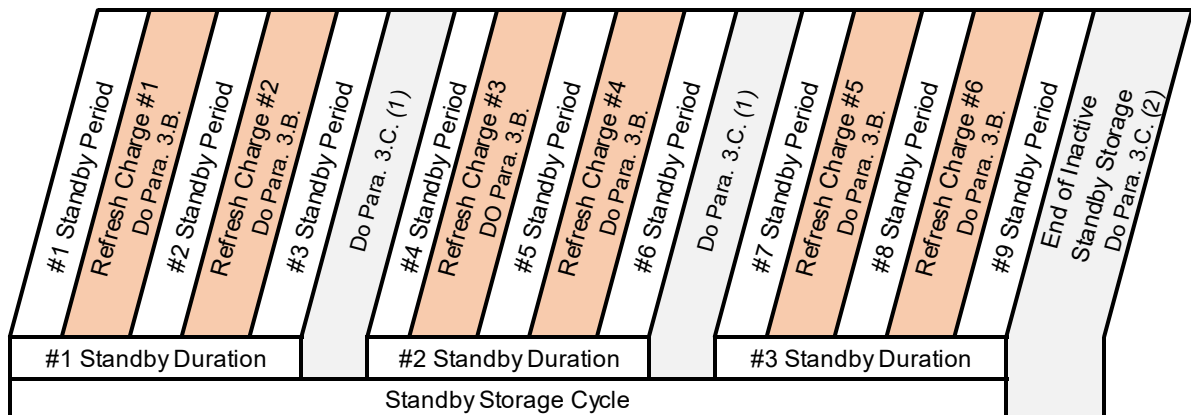

Inactive Standby Storage Schedule  
Figure 15002



COMPONENT MAINTENANCE MANUAL  
43B050KB01 / 43B050KB02

4. Active Standby Mode (Trickle Charge)

**CAUTION:** WATER CONSUMPTION OCCURS WHEN THE BATTERY IS CONTINUOUSLY CHARGED, IN AN OVERCHARGE CONDITION. SAFT DOES NOT RECOMMEND THIS METHOD, HOWEVER SOME OPERATORS TAKE RESPONSIBILITY FOR ITS USE.

**NOTE:** This method is not reliable due to quantity and inaccuracy of water consumption.

Example: A 40 Ah battery on a continuous trickle charge of 3 mA/Ah for one month may consume over 35 cm<sup>3</sup>/cell (2.14 in<sup>3</sup>/cell) of water.

5. Storage of spare parts

A. Spare Cells

Spare cells must be stored in a vertical upright position, filled, and discharged condition (electrolyte levels are not visible in discharged cells). It is not necessary to short circuit the cells. The vent valves must be installed. The storage conditions are the same as those given in paragraph Inactive long-term storage. No maintenance operation is needed during storage. Before installation in a battery, cells must be visually inspected for damage or leakage and repaired as necessary in accordance with this CMM.

B. Spare O-rings, gaskets, and vent valves

(1) O-rings and gaskets

Six (6) years of storage period starts from the date of manufacture unless otherwise specified on the packaging. The O-rings and gaskets should be protected from exposure to the air, light, and high humidity < 85%. Storage life depends on temperature. It is recommended to store the parts in a cool area < +25°C (+77°F). Above +35°C (+95°F), storage life is reduced to 5 years. Before use the O-rings or gaskets it must be inspected. In case of visible signs of damage, distortion, or deterioration, the part must be discarded.

O-rings must be inspected before use and must be disregarded if there are visible signs of damage, distortion, or deterioration.

(2) Vent valves with O-rings

Six (6) years of storage period starts from the date of manufacture unless otherwise specified on the packaging. The vent valves and O-rings should be protected from exposure of air, light and high humidity (< 85 %). Storage life depends on temperature. It is recommended to store the parts in a sealed container (non-PVC) in a cool area < +25°C (+77°F). Above +35°C (+95°F), storage life is reduced to 5 years. Before use the vent valves and O-rings it must be inspected. In case of visible signs of damage, deformation, or deterioration, the vent valve and O-ring must be discarded.

C. Other spares

Other spares, protected from external contamination (i.e., dirt, dust, dampness, vibration, corrosive atmosphere) and high humidity (> 85%), may be stored for unlimited periods. Before use, they must be inspected and any showing visible signs of damage, distortion or deterioration must be discarded.

**24-30-11**

15004  
Nov 14/2022





COMPONENT MAINTENANCE MANUAL  
43B050KB01 / 43B050KB02

6. Transportation procedure

The battery is normally discharged before packing. If it is necessary to transport a charged battery, make sure that the output terminals are protected against short circuit.

The battery should then be packed vertically in its original container. If the original container is not available, the international and/or local packaging regulations applicable to the mode of transport and destination must be followed.

According to the IATA / IMDG dangerous goods regulations, Saft ships all existing nickel cadmium batteries or cells for aircraft under the classification UN2795 (wet, filled with alkali).

**24-30-11**

15005  
Nov 14/2022



COMPONENT MAINTENANCE MANUAL  
43B050KB01 / 43B050KB02

PAGE INTENTIONALLY LEFT BLANK

**24-30-11**

15006  
Nov 14/2022