



(F6177)

26 quai C. Pasqua - 92300 Levallois-Perret - France
Tél. +33 1 58 63 16 90 - Fax: +33 1 58 63 16 18

MAINTENANCE MANUAL WITH ILLUSTRATED PARTS LIST

AIRCRAFT BATTERY

443CH1

P/N: 416470

date of creation: Nov 23/2020

24-36-06

edition 1
Jul 27/2021



**Component Maintenance Manual
443CH1**

This document and all information contained herein are the property of Saft. Its use is restricted solely to the maintenance of Saft batteries and may under no circumstances be used for any other manufacturer's products. No person may, in whole or in part, duplicate, use or disclose this information for any other purpose without the prior written consent of Saft.

RECORD OF REVISIONS

Rev. n°	Issue date	Inserted		Rev. n°	Issue date	Inserted	
		Date	By			Date	By
00	Nov 23, 2020	Nov 23, 2020	Saft				
01	Jul 27, 2021	Jul 27, 2021	Saft				



**Component Maintenance Manual
443CH1**

PAGE INTENTIONALLY LEFT BLANK

RECORD OF TEMPORARY REVISIONS

Rev. n°	Issue date	Inserted		Rev. n°	Issue date	Inserted	
		Date	By			Date	By



**Component Maintenance Manual
443CH1**

PAGE INTENTIONALLY LEFT BLANK



Component Maintenance Manual
443CH1

SERVICE BULLETIN LIST

Service bulletin		Incorporation into CMM		Title
Number	Rev.	Date	Rev.	



**Component Maintenance Manual
443CH1**

PAGE INTENTIONALLY LEFT BLANK



Component Maintenance Manual
443CH1

LIST OF EFFECTIVE PAGES

TITLE PAGE	1	Jul 27/2021	DESCRIPTION AND	1	Jul 27/2021
	2	Jul 27/2021	OPERATION	2	Jul 27/2021
				3	Jul 27/2021
RECORD	ROR-1	Jul 27/2021		4	Blank
OF REVISIONS	ROR-2	Blank			
			TESTING AND FAULT	1001	Jul 27/2021
RECORD OF TEMPO-	RTR-1	Jul 27/2021	ISOLATION	1002	Jul 27/2021
RARY REVISIONS	RTR-2	Blank		1003	Jul 27/2021
				1004	Blank
SERVICE BULLETIN	SBL-1	Jul 27/2021			
LIST	SBL-2	Blank	DISASSEMBLY	3001	Jul 27/2021
				3002	Jul 27/2021
LIST OF EFFECTIVE	LEP-1	Jul 27/2021			
PAGES	LEP-2	Jul 27/2021	CLEANING	4001	Jul 27/2021
				4002	Jul 27/2021
TABLE OF CON-	TOC-1	Jul 27/2021			
TENTS	TOC-2	Jul 27/2021			
	TOC-3	Jul 27/2021			
	TOC-4	Blank			
LIST OF ILLUSTR-	LOI-1	Jul 27/2021			
TIONS	LOI-2	Blank			
INTRODUCTION	Intro-1	Jul 27/2021			
	Intro-2	Jul 27/2021			
	Intro-3	Jul 27/2021			
	Intro-4	Jul 27/2021			
	Intro-5	Jul 27/2021			
	Intro-6	Blank			



**Component Maintenance Manual
443CH1**

INSPECTION/CHECK	5001	Jul 27/2021	ILLUSTRATED	10001	Jul 27/2021
	5002	Jul 27/2021	PARTS LIST	10002	Jul 27/2021
	5003	Jul 27/2021		10003	Jul 27/2021
	5004	Jul 27/2021		10004	Jul 27/2021
	5005	Jul 27/2021		10005	Jul 27/2021
	5006	Jul 27/2021		10006	Jul 27/2021
	5007	Jul 27/2021		10007	Jul 27/2021
	5008	Jul 27/2021		10008	Blank
	5009	Jul 27/2021			
	5010	Jul 27/2021	STORAGE	15001	Jul 27/2021
			(INCLUDING	15002	Jul 27/2021
ASSEMBLY	7001	Jul 27/2021	TRANSPORTATION)	15003	Jul 27/2021
	7002	Jul 27/2021		15004	Jul 27/2021
	7003	Jul 27/2021			
	7004	Jul 27/2021			
	7005	Jul 27/2021			
	7006	Blank			
FITS AND CLEARANCES	8001	Jul 27/2021			
	8002	Blank			
SPECIAL TOOLS, FIXTURES, EQUIPMENT AND CONSUMABLES	9001	Jul 27/2021			
	9002	Jul 27/2021			

TABLE OF CONTENTS

RECORD OF REVISIONS	ROR-1
RECORD OF TEMPORARY REVISIONS	RTR-1
SERVICE BULLETIN LIST	SBL-1
LIST OF EFFECTIVE PAGES	LEP-1
TABLE OF CONTENTS	TOC-1
LIST OF ILLUSTRATIONS	LOI-1
INTRODUCTION	-INTRO-1
1. General	INTRO-1
2. Definitions	INTRO-1
3. Safety	INTRO-1
3-1. Physical	INTRO-1
3-2. Electrical	INTRO-1
3-3. Chemical	INTRO-1
4. Ground applications	INTRO-2
5. Placing a new battery in service - initial commissioning	INTRO-2
6. Battery ratings capacity	INTRO-2
7. Recycling	INTRO-2
8. End of life cells	INTRO-2
9. Measurements	INTRO-3
9-1. Units of measure	INTRO-3
9-2. Measurement conversion table	INTRO-4
9-3. Temperature conversion table	INTRO-5
9-4. Abbreviations	INTRO-6
DESCRIPTION AND OPERATION	1
1. Description	1
2. Technical data	1
2-1. Characteristics	1
3. Description	1
4. Operation	2
4-1. Climatic requirement	2
4-2. Maintenance	2
5. Charge	2
5-1. Constant current charge	3
5-2. Other methods of charging	3
5-3. Active standby mode (= use of a trickle charge)	3
TESTING AND FAULT ISOLATION	1001
1. Introduction	1001
2. Battery faults	1001
2-1. Battery electrical faults	1001
2-2. Cell faults	1002
2-3. Physical faults	1003
DISASSEMBLY	3001
1. Introduction	3001
1-1. General	3001
1-2. Safety	3001
1-3. Job Set-up Information	3001
2. Disassembly of the battery	3001
2-1. Removal of the complete cover (020)	3001

2-2. Removal of the cells (180) -----	3001
2-3. Remove the liner-spacer kit (240), -----	3001
2-4. Remove the one-way valve (370) -----	3001
2-5. Removal of the power connector (280) -----	3001
2-6. Removal of the sensor connector (340) -----	3002

CLEANING ----- 4001

1. Introduction -----	4001
2. Safety -----	4001
3. Equipment -----	4001
3-1. Standard tools -----	4001
3-2. Special tools -----	4001
3-3. Consumables -----	4001
4. Light cleaning -----	4001
4-1. Procedure -----	4001
5. Thorough cleaning -----	4001
5-1. Procedure -----	4001
5-2. Lubrication -----	4002

INSPECTION/CHECK ----- 5001

1. Introduction -----	5001
2. Maintenance intervals -----	5001
2-1. Periodical check -----	5001
2-2. Regular check -----	5001
2-3. General overhaul -----	5001
3. Recording -----	5001
4. Safety -----	5001
5. Equipment -----	5001
5-1. Standard tools -----	5001
5-2. Special tools -----	5001
6. Periodical check -----	5002
6-1. Visual inspection -----	5003
6-2. Insulation check -----	5003
6-3. Nut tightness -----	5004
6-4. Open circuit voltage check -----	5004
6-5. Polarization test -----	5004
6-6. Residual discharge -----	5004
6-7. Adjust electrolyte level -----	5004
6-8. Supplementary test -----	5005
7. Regular check -----	5006
7-1. Cell shorting -----	5007
7-2. Capacity check -----	5007
8. General overhaul -----	5008
8-1. Component inspection -----	5009
8-2. Replacement of faulty components -----	5009
8-3. Sensor connector check -----	5009
8-4. Vent-valve test -----	5010

ASSEMBLY ----- 7001

1. Introduction -----	7001
2. Safety -----	7001
3. Equipment -----	7001
3-1. Standard tools -----	7001
3-2. Special tools -----	7001
4. Battery assembly -----	7001
4-1. Installation of the sensor connector assembly (330) -----	7001
4-2. Installation of the power connector (280) -----	7002
4-3. Installation of the one-way valve (370) -----	7002
4-4. Installation of the liner-spacer kit (240) -----	7003
4-5. Cells installation (180) -----	7005
4-6. Recording -----	7005



**Component Maintenance Manual
443CH1**

FITS AND CLEARANCES ----- 8001

- 1. Introduction ----- 8001
- 2. Torque table ----- 8001

SPECIAL TOOLS, FIXTURES, EQUIPMENT AND CONSUMABLES ----- 9001

- 1. Introduction ----- 9001
- 2. Standard tools ----- 9001
- 3. Special tools ----- 9001
- 4. Consumables ----- 9002

ILLUSTRATED PARTS LIST -----10001

- 1. Introduction ----- 10001
 - 1-1. General ----- 10001
 - 1-2. Alpha numerical index ----- 10001
 - 1-3. Detailed parts list ----- 10001
- 2. Alpha numerical index ----- 10003
- 3. Detailed part list ----- 10005

STORAGE (INCLUDING TRANSPORTATION) -----15001

- 1. Introduction ----- 15001
 - 1-1. General ----- 15001
 - 1-2. Storage room ----- 15001
 - 1-3. Climatic conditions ----- 15001
- 2. Storage ----- 15001
 - 2-1. Inactive long-term storage ----- 15001
 - 2-2. Inactive standby storage ----- 15001
- 3. Storage of spares ----- 15004
 - 3-1. Spare Cells ----- 15004
 - 3-2. Spare O-rings, gaskets and vent-valves ----- 15004
- 4. Transportation procedure ----- 15004



**Component Maintenance Manual
443CH1**

PAGE INTENTIONALLY LEFT BLANK

LIST OF ILLUSTRATIONS

INTRO-1	INTRO-1 - Universal recycling symbols	page INTRO-2
1	1 - 443CH1 Nickel-Cadmium aircraft battery	page 2
5001	5001 - Periodical check	page 5002
5002	5002 - Position of syringe in cell vent seat	page 5005
5003	5003 - Regular check	page 5006
5004	5004 - General overhaul	page 5008
7001	7001 - Connector sensor assembly	page 7001
7002	7002 - One-way valve installation	page 7002
7003	7003 - Liner-spacer kit	page 7003
7004	7004 - Battery layout	page 7005
10001	10001 - 443CH1 Nickel-Cadmium Aircraft Battery	page 10005
15001	15001 - Standby storage period	page 15002
15002	15002 - Inactive standby storage	page 15003



**Component Maintenance Manual
443CH1**

PAGE INTENTIONALLY LEFT BLANK

INTRODUCTION

1. General

This manual provides the information necessary for an experienced shop technician to maintain Saft nickel-cadmium batteries. It describes the construction of the battery as well as the techniques used to operate, maintain, overhaul, and generally care for the battery. Following these instructions will make sure of optimal performances and life of the Saft batteries.

All aircraft batteries require checking and maintenance in order to make sure they are safe when installed and perform their required functions, especially in emergency conditions on board the aircraft. Maintenance permit to identify and correct any issues to be identified. Proper battery maintenance assures a low probability of failure. It achieves high levels of MTBUR and MTBF. Failure prevention on board the aircraft make sure of safe operation, reduces delays and operational costs.

Every effort has been made to provide complete and accurate instructions. If a situation should arise that is not adequately described in this manual, please contact Saft via the Internet at www.saftbatteries.com/ or at one of the following addresses:

Saft America Inc. (V09052)
711 Gil Harbin Industrial Boulevard
Valdosta, Georgia 31601 - USA
Tel: +1 (229) 247-2331
Fax: +1 (229) 247-8486

Saft (F6177)
26 quai C. Pasqua
92300 Levallois-Perret - France
Tel: +33 1 58 63 16 00
fax: +33 1 58 63 16 18

Website All Saft technical documentation, distributors and repair shops can be found at www.saftbatteries.com/cmm.

2. Definitions

WARNING: WARNINGS ADVISE TO USE OF MATERIALS, PROCEDURES, OR LIMITS, WHICH MUST BE FOLLOWED PRECISELY TO AVOID PERSONAL INJURIES, OR EFFECT SAFETY OF FLIGHT.

CAUTION: CAUTIONS CALL ATTENTION TO PROCEDURES WHICH MUST BE FOLLOWED TO AVOID DAMAGE TO EQUIPMENT OR PARTS.

NOTE: NOTES call attention to procedures which make the job easier.

3. Safety

CAUTION: EXCEPT FOR THOSE STEPS THAT REQUIRE THE BATTERY TO BE CHARGED, DO ALL STEPS ON DISCHARGED BATTERIES (REFER TO [Residual discharge](#) PARAGRAPH) TO AVOID THE POSSIBILITY OF ELECTRIC SHOCK. TIGHTEN VENT-VALVES ([230](#)) BEFORE THE START OF THE DISCHARGE. BATTERY CELLS DELIVER VERY HIGH CURRENT WHEN SHORT-CIRCUITED. BE CAREFUL. REMOVE RINGS, WATCHES, NECKLACES, METALLIC BELTS OR OTHER JEWELRY TO AVOID ELECTRIC SHOCK.

CAUTION: DO NOT TILT THE BATTERY WHILE DOING MAINTENANCE, ANY CONTACT OF SKIN WITH ELECTROLYTE CAN CAUSE SEVERE BURNS.

Local safety regulations should be followed as safety regulations are country-dependent.

There are three types of risks:

3-1. Physical

- Handling: the battery is heavy. Use proper technique when lifting heavy loads. Bend your legs and not your back
- Wear protective shoes

3-2. Electrical

- Do not wear rings, watches, chains, belt buckles, necklaces or any other conductive objects
- Use insulated tools

3-3. Chemical

- For a complete listing of hazards, refer to the Battery Information Sheet (BIS) available on Saft's website at www.saftbatteries.com/cmm
- Electrolyte is very corrosive and can damage the skin. Use proper personal protective equipment (PPE) such as gloves and an apron. If it touches the skin, flush affected area with large quantities of water. After flushing begins, remove all contaminated clothing
- Electrolyte is very dangerous to the eyes, use protective goggles. If the electrolyte comes in contact with the eyes, flush with water for 15 to 30 minutes and get immediate medical aid
- Saft recommends the use of an amphoteric solution (both acidic and basic behavior) and chelator (able to trap cations as a chelate complex) to neutralize electrolyte according to the local regulation

- Electrolyte ingestion can cause damage to the throat and the respiratory tract. Do not try to vomit. Get medical aid immediately
- Skin contact with nickel can cause chronic eczema
- Inhalation of cadmium oxide can cause dry throat, headaches, vomiting, chest pain, and difficulties breathing. If inhaled, get fresh air. If stops breathing, give artificial respiration. If breathing becomes difficult, give oxygen. Get medical aid immediately
- Potassium hydroxide in the electrolyte can cause eczema

4. Ground applications

Saft batteries can be used in ground applications for starting gas turbine generators, powering ground mobile equipment, or in shop testing equipment. The same principles used in flight operations apply when the battery is used in ground applications. Ventilation of the battery during ground use can be accomplished through a ventilation system or by simply removing the cover (only in a well-ventilated area). Check with your local authorities for regulations in effect.

5. Placing a new battery in service - initial commissioning

NOTE: Whether or not the battery has been subject to disassembly and reassembly, before to issue in service and installation certificate, check the tightness of all upper nuts to verify that torque values correspond with those specified (refer to chapter [Nut tightness](#)).

Before installation of the battery into the aircraft for service:

- If initial commissioning is performed within 12 months then do [Visual inspection](#), [Insulation check](#), [Nut tightness](#), [Charge Adjust electrolyte level](#), and repeat [Insulation check](#)
- If initial commissioning is performed after 12 months do [Charge](#) and [Regular check](#)

Starting date for this period is the date of manufacturing (DMF).

6. Battery ratings capacity

Nickel-cadmium batteries are rated in terms of capacity in ampere-hours (Ah) (rated capacity).

American Standard AS8033 defines capacity as "the dischargeable ampere-hours (Ah) available from a fully charged cell/battery at any specified discharge rate/temperature condition".

Other definitions for battery ratings can be found in EN2570, IEC 60952 and RTCA DO 293.

A battery rated for 1C₁ Ah indicates that the battery is rated at a value based upon a discharge time of 1 hour at +23 °C ± 3 °C (+73.4 °F ± 5.4 °F).

7. Recycling

All batteries eventually lose their ability to perform and are eligible for scrap and recycling. Saft takes environmental matters seriously and advocates proper recycling of nickel-cadmium batteries and their components. To that end, Saft operates recycling facilities in both Europe and North America.

Nickel-cadmium batteries contain nickel, cadmium, and potassium hydroxide and should be disposed of properly. In all cases, rely on local and national regulations for proper battery disposal and/or shipping to an appropriate recycling location.

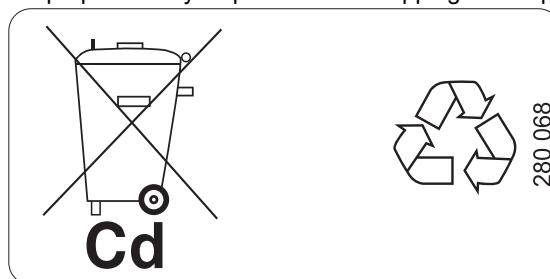

Figure INTRO-1 - Universal recycling symbols

You can find the nearest recycling collection point on our website at www.saftbatteries.com.

8. End of life cells

EASA and FAA regulations 'Part 145', require that end of life cells must be disposed of in a manner that does not allow them to be returned to service. The following procedure provides a means to comply with these regulations.

While other authority requirements may be less explicit, Saft recommends that the following procedures be adopted in order to make sure that end of life cells cannot be re-used:

- Make sure that appropriate protective measures (refer to [Safety](#) paragraph and the Battery Information Sheet (BIS)) are taken
- Make sure that the cell(s) is (are) fully discharged (refer to [Cell shorting](#) paragraph)
- Break or cut the terminals. In the event of electrolyte leakage, make sure that appropriate spill clean up measures are observed as described in the Battery Information Sheet (BIS)
- Individually bag each cell in a liquid proof bag and dispose of the cell in accordance with applicable transport, health and safety and recycling regulations (Refer to [Recycling](#) paragraph)

9. Measurements

The measurements given in this manual comes from the original manufacturer drawings.

This CMM uses the International System (SI) of units for quantities and values. Additionally US Imperial units are given in parenthesis.

9-1. Units of measure

9-1-1. SI units

A	Ampere
Ah	Ampere hours
Bar	Bar
C ₁ A	Rated current
C ₁ Ah	Rated capacity for an hour
cm ³	Centimeter cube
g	Gram
h	Hour
m	Meter
min	Minute
N	Newton
N.m	Newton meter
Pa	Pascal
VDC	Volt direct current
°C	Degree Celsius
%	Per cent
Ω	Ohm
μS/cm	Microsiemens per centimeter

9-1-2. US Imperial units

ft	Foot
in	Inch
in.Hg	inch of Mercury
lb	Pound
lbf.in	Pound force inch
PSI	Pound per Square Inch
°F	Degree Fahrenheit

9-1-3. Multiplying prefixes

da	deca
h	hecto
k	Kilo
M	Mega
m	Milli
μ	Micro

9-2. Measurement conversion table**9-2-1. From SI unit to US Imperial unit**

1 Bar	14.504 psi
1 cm	0.3937 in
1 cm ²	0.1550 in ²
1 cm ³	0.06 in ³
1 g	0.0353 oz
1 g/l	0.000578 oz/in ³
1 hPa	0.01450 psi
1 kg	2.2046 lb
1 kg/l	0.578 oz/in ³
1 mm	0.0394 in
1 N	0.2248 lbf
1 N.m	8.8507 lbf.in

9-2-2. From US Imperial unit to SI unit

1 gal (U.S.)	3.7854 l
1 in	2.54 cm
1 in	25,4 mm
1 in ²	6.4516 cm ²
1 in ³	16.4 cm ³
1 in.Hg	33.864 hPa
1 lb	0.4536 kg
1 lbf	4.4482 N
1 lbf.in	0.1130 N.m
1 lbf.ft	1.3558 N.m
1 oz	28.3495 g
1 oz/in ³	1,771.25 g/l
1 oz/in ³	1.771 kg/l
1 psi	68.948 hPa
1 psi	0.0689 Bar

9-3. Temperature conversion table

9-3-1. From degrees Fahrenheit (°F) to degrees Celsius (°C)

Celsius = (Fahrenheit - 32) x 0.5555

9-3-2. From degrees Celsius (°C) to degrees Fahrenheit (°F)

Fahrenheit = (Celsius x 1.8) + 32

9-4. Abbreviations

The abbreviations given below are used in this manual:

AECMA	European Association of Aerospace Industries
ATA	Air Transport Association of America
dia.	diameter
DMF	Date of Manufacturing
EASA	European Air Safety Authority
FAA	Federal Aviation Authority
fig.	figure
IATA	International Transport Air Association
IMDG	International Maritime Dangerous Goods
ipl	illustrated parts list
max.	maximum
mfr	manufacturer
min.	minimum
MTBF	Mean Time Between Failure
MTBUR	Mean Time Between Unscheduled Removal
n°	number
p/n	part number
para.	paragraph
PPE	Personal Protective Equipment
ref.	refer to
s/a	subassembly
SI	International System of Unit
TBD	To Be Defined
V	Voltage



**Component Maintenance Manual
443CH1**

PAGE INTENTIONALLY LEFT BLANK

DESCRIPTION AND OPERATION

1. Description

The batteries are connected to the aircraft system:

- According to the aircraft manufacturer and / or operator, to start the engine or the APU
- On the ground, to provide power before electrical power is supplied to the aircraft systems
- In flight, if a malfunction or a failure occurs in the power supply system

2. Technical data

2-1. Characteristics

Battery characteristics are indicated in the table below.

Technical data	Values
Type of cells	CVH441KH
Number of cells	20
Nominal voltage	24 V
Rated capacity C ₁	44 Ah
Charge or discharge current 1 C ₁	44 A
Charge current 0.5 C ₁	22 A
Charge current 0.1 C ₁	4.4 A
Electrolyte	Solution of KOH
Nozzle length	20 mm (0.79 in)
Consumable volume of electrolyte per cell	25 cm ³ (1.52 in ³)
Minimum end of charge voltage	1.55 V per cell
End of life criterion in %	100 %
End of life criteria in hour or minutes	1 hour
Battery maximum weight	38.5 kg (84.9 lb)
Battery terminals	Power connector according to ISO 5064/11 or MS 3509

Table 1 - Battery characteristics

3. Description

NOTE: The item numbers are those of the detailed parts list chapter (Refer to [Detailed part list](#)).

The [443CH1](#) Saft nickel-cadmium battery consists of a box ([380](#)), containing [20](#) individual cells [CVH441KH](#). These cells are connected in series to provide a [24 V](#) nominal system. Individual cells are enclosed in a polyamide container that provides insulation, allowing them to be fitted side-by-side in the battery box. Cells are interconnected with rigid, highly conductive, nickel-plated copper links ([110](#) to [170](#)). Each link is held in position by nuts ([070](#)) and washers ([080](#)) on the cells' terminals. Inside the battery box ([380](#)), individual cells ([180](#)) are held in position by partitions, liners and spacers ([240](#)), and a cover ([020](#)).

The power connector ([280](#)) connects the battery to the aircraft DC power.

The cover ([020](#)), which can be removed, is attached to the box ([380](#)) by latches.

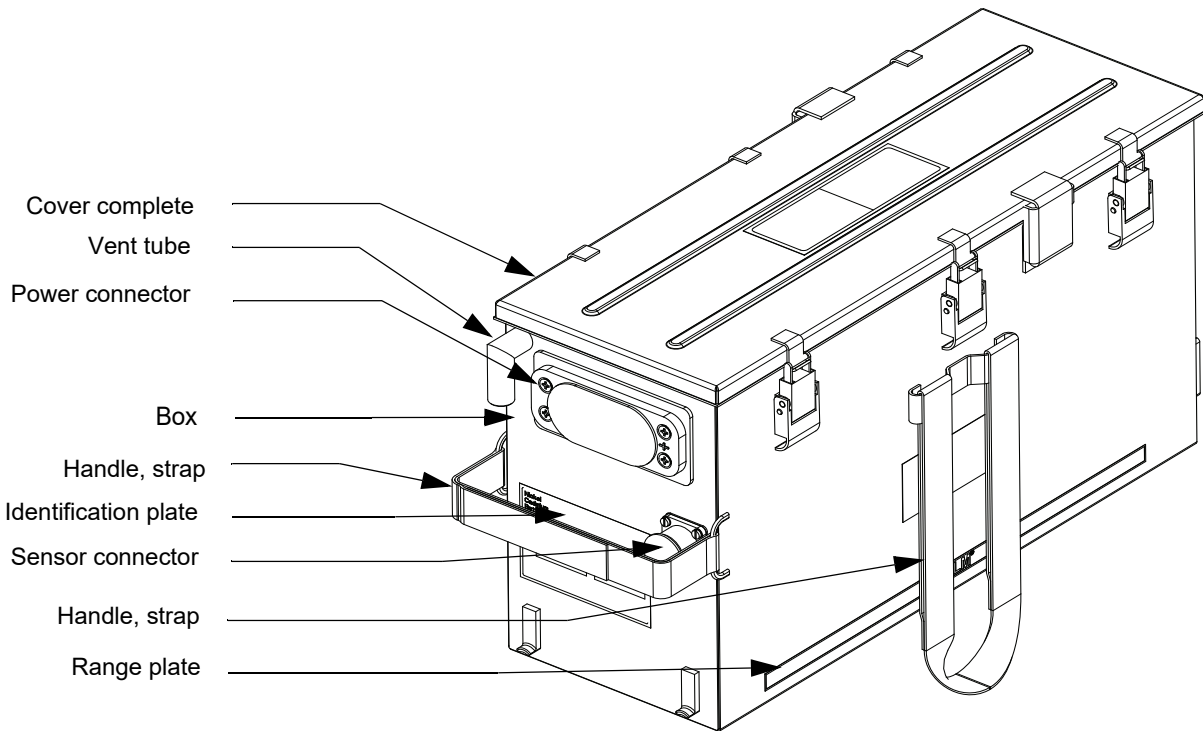

Figure 1 - [443CH1](#) Nickel-Cadmium aircraft battery

4. Operation

4-1. Climatic requirement

Although Saft nickel-cadmium batteries are capable of operating in a wide temperature range -40°C (-40°F) and $+71^{\circ}\text{C}$ ($+160^{\circ}\text{F}$), optimum performance is reached between $+5^{\circ}\text{C}$ ($+41^{\circ}\text{F}$) and $+45^{\circ}\text{C}$ ($+113^{\circ}\text{F}$). Charging is inefficient at temperatures below -30°C (-22°F) and is not recommended above $+57^{\circ}\text{C}$ ($+135^{\circ}\text{F}$). Charging must be stopped at temperatures above $+71^{\circ}\text{C}$ ($+160^{\circ}\text{F}$).

Unless otherwise stated, charge and discharge testing should be done when

- The battery temperature is between $+15^{\circ}\text{C}$ ($+59^{\circ}\text{F}$) and $+35^{\circ}\text{C}$ ($+95^{\circ}\text{F}$)
- Pressure 750 to 1060 hPa (22.15 to 31.3 in.Hg)
- Relative humidity $< 85\%$

4-2. Maintenance

All maintenance, including charging and discharging, should be done specifically in accordance with the instructions contained in this Component Maintenance Manual (CMM).

5. Charge

The charge, also called maintenance charge, is done in 2 steps:

- Step 1: called "charge" or "main charge", is a constant current charge with three possible charge rates
- Step 2: called "overcharge" or "final charge", is also a constant current charge with only one possible charge rate

5-1. Constant current charge

CAUTION: IN STEP 1, A CELL WITH A VOLTAGE OF MORE THAN 1.7 V AT 0.1C₁A OR MORE THAN 1.75 V AT 0.5C₁ OR MORE THAN 1.75 V AT 1C₁A IS DEFECTIVE. REPLACE THE DEFECTIVE CELL WITH A NEW SAFT CELL.

NOTE: Check cell voltage at the beginning of the charge. If any cell indicates an immediate voltage rise above 1.5 V, add 5 cm³ (0.3 in³) of distilled or deionized water [M01](#) to that cell.

NOTE: Always apply the main charge for no less than duration.

Starting with a discharged battery:

- Remove the cover complete ([020](#))
- Loosen, but do not remove, all vent-valves ([230](#))
- Remove power connector cover ([290](#)) -if present-
- Charge using one of the methods shown in the table below (step 1) main charge
- After the minimum charge duration is reached, measure the voltage on each cell ([180](#)) and compare the values with the end of (step 1) main charge criteria in the table below
- During the last 15-30 minutes of the (step 2) final charge cycle, [Adjust electrolyte level](#)

Charge of the battery				
(step 1) Main Charge			(step 2) Final Charge	
Current	Minimum duration	End of main charge criteria	Current and time	Minimum voltage criteria
0.1 C ₁ A* or 4.4 A	10 h	Every cell > 1.5 V or 12 h which ever comes first	4.4 A for 4 h	1.55 V per cell
0.5 C ₁ A or 22 A	2 h	Every cell > 1.55 V or 2.5 h which ever comes first	4.4 A for 4 h	1.55 V per cell
1 C ₁ A or 44 A	1 h	Every cell > 1.57 V or 1.25 h which ever comes first	4.4 A for 4 h	1.55 V per cell

Table 2 - Charge rates

(*) Low charge rate 0.1 C₁A or [4.4 A](#) is suggested after cell shorting.

Example: main charge (step 1) at [44 A](#) for 1 h:

- If the voltage of each cell is lower than 1.57 V, continue the charge for 15 minutes maximum (0.25 h) and stop if the voltage reach 1.57 V before 15 minutes. Then continue with the final charge (step 2)
- If the voltage of each cell is higher than 1.57 V, continue with the final charge (step 2)

5-2. Other methods of charging

NOTE: Do not use this procedure for charging the battery during normal maintenance

Other methods that fully charge the battery can be used, for example pulse charging. However, in any case, individual cell voltage checks ($U \geq 1.55 \text{ V per cell}$) and electrolyte adjustments must be carried out using a final overcharge sequence at constant current [4.4 A](#) for 4 hours. If specific instructions are not given in the charger operating manual, you must first contact Saft.

5-3. Active standby mode (= use of a trickle charge)

WARNING: THIS MAY CREATE CONDITIONS FOR A THERMAL RUNAWAY WITH ALL ITS CONSEQUENCES (UN-SCHEDULED REMOVAL WITH THE POSSIBILITY OF THE TOTAL LOSS OF THE BATTERY AND A DELAYED OR CANCELED FLIGHT).

CAUTION: WATER CONSUMPTION.

The battery is continuously charged to an overcharge condition. Saft does not recommend this method, however some operators take responsibility for its use.

This method is not reliable due to quantity and inaccuracy of water consumption.

Example: if a 40 Ah battery remains on a continuous trickle charge of 3 mA/Ah for one month, the total consumption of water is 35 cm³ (2.1 in³)cell.

The operator must adjust the electrolyte level before placing the battery on board the aircraft. Otherwise the risk of a battery incident exists (cells dry out before the normal end of the interval maintenance).



**Component Maintenance Manual
443CH1**

PAGE INTENTIONALLY LEFT BLANK

TESTING AND FAULT ISOLATION

1. Introduction

This chapter is a maintenance guide for the technician.

It shows, for the main causes of failure, either removed for unscheduled maintenance or during scheduled maintenance, the procedures to apply by referring to the corresponding chapter of the CMM. In no case can this diagnosis help replace the technician's expertise or a training on the functioning of the batteries.

2. Battery faults

2-1. Battery electrical faults

Problem	Probable cause	Correction
(1) Zero battery open-circuit voltage	(a) Defective electrical connector (no contact made) (b) Link broken	- Check electrical contacts, links and tightness of nuts (refer to Inspection/check)
(2) Zero volt with the battery set to "discharge"	(a) Battery fully discharged (b) Battery circuit open or contacts defective (c) Cell completely dry	- Do an insulation check (refer to Inspection/check) - Examine the contacts and links - Make sure the terminal nuts are tight (refer to Inspection/check) - Refer to related subsequent steps - Replace the cell
(3) Low insulation	(a) Leakage of electrolyte	- Disassemble and clean the battery (refer to Disassembly and Cleaning) - Do an electrolyte level check (refer to Inspection/check)

Table 1001 - Battery electrical faults

2-2. Cell faults

Problem	Probable cause	Correction
(1) Too much water decrease for all battery cells	(a) Charge much more than the limit or too much charge at high temperature (b) Previous maintenance has not been done	- Examine the cause of excessive charge - If necessary, adjust to normal operating temperature (refer to Description and operation) - Note the cell location and check the level of water consumption versus other cells at the next maintenance
(2) High water dispersion: water consumption in one or more cell(s) is very different from the other cells in the battery	(a) more than 30 % above the average value of added water in all cells: leaking cell(s) (b) less than 30 % below the average value of added water in all cells: cell(s) with damaged separator(s)	- Disassemble the battery (refer to Disassembly). Clean the battery (refer to Cleaning). Replace the cell(s). Charge and do an electrolyte level check (refer to Inspection/check) - Do the Supplementary test (refer to Inspection/check). If necessary, replace the cell(s)
(3) A cell has a higher voltage at the start of charge than is defined in para. Charge chapter Description and operation	(a) Dry cell	- When the defect occurs, add 5 cm ³ (0.3 in ³) of distilled water M01 to the cell. Do not adjust more accurately until the end of the charge
NOTE: If you charge a cell with a quantity of electrolyte which is not sufficient, this can cause the temperature to increase too much		
(4) A cell has a lower voltage at the end of charge than is defined in para. Charge chapter Description and operation	(a) The cell was operated at temperatures and charge rates outside the limits, and the separator is damaged (b) Usual wear after long operation	- Replace the cell (refer to Disassembly, Assembly AND Storage (including transportation))
(5) Low capacity cell	(a) insufficient balancing (b) Usual wear after long operation (c) Unusual operation, operation at high temperature or operation with low electrolyte	- Repeat Charge , discharge at 44 A and Cell shorting up to three times - Replace the cell (refer to Disassembly, Assembly AND Storage (including transportation)) - Do the applicable procedure (refer to Inspection/check)
(6) Cell with a swollen case	(a) Cell operated with low electrolyte level; deterioration of separators and damaged plates	- Replace the cell (refer to Disassembly)
(7) Cell with zero voltage when the battery circuit is open	(a) Short-circuited cell	- Replace the cell (refer to Disassembly)

Table 1002 - Cell faults

2-3. Physical faults

Problem	Probable cause	Correction
(1) Leakage of electrolyte	<p>(a) Incorrect adjustment of electrolyte level</p> <p>(b) Cell polarity incorrect during high-rate discharge (for example, during the engine start)</p> <p>(c) Too much charge at high temperature or too much current</p> <p>(d) The lower nut is not correctly tightened</p>	<ul style="list-style-type: none"> - Disassemble and clean the battery (refer to Disassembly and Cleaning chapters). Do an electrolyte level check (refer to Inspection/check) - Disassemble and clean the battery (refer to Disassembly and Cleaning) Do an electrolyte level check (refer to Inspection/check) - Investigate the cause of excessive charge. If necessary, adjust to normal operating temperature (refer to Description and operation) - Disassemble and clean the battery (refer to Disassembly and Cleaning) - Do an electrolyte level check (refer to Inspection/check) - Torque the lower nut (refer to Assembly chapter)
(2) Electrolyte found in the battery box	<p>(a) Damaged cell case</p> <p>(b) Leakage of electrolyte</p>	<ul style="list-style-type: none"> - Replace the cell if necessary and refer to related subsequent steps - Disassemble and clean the battery (refer to Inspection/check and Cleaning) - Do an electrolyte level check (refer to Inspection/check)
(3) Corrosion on the links	<p>(a) Operation in acidic air</p> <p>(b) Mechanical damage to nickel plating</p>	<ul style="list-style-type: none"> - Make sure the battery test bench and the storage areas have no materials which can give off acid fumes - Replace the damaged links (refer to Disassembly, Assembly)
(4) The links are too hot	(a) Loose terminals nuts	<ul style="list-style-type: none"> - Make sure the nuts are torqued (refer to Inspection/check)
(5) Battery case & cover damages; - Scratches - Dents, deformations which affect fit or impede the electrical performances of the battery or any of its components - Visible cracks to case or cover	<p>(a) Various, transport</p> <p>(b) Mechanical stress, drop, transport</p> <p>(c) Mechanical stress, drop, transport</p>	<ul style="list-style-type: none"> - Clean, make sure labels are readable, if not readable replace label(s) - Replace battery case, cover, and affected component(s) (refer to Disassembly) - Replace battery case and / or cover
(6) During flight, the battery produces high pitch sounds (whistle like)	<p>(a) Damaged one-way valve; cut, deformation, or tape at the vent tip is deteriorated or gone</p> <p>(b) Debris or foreign object in one-way valve</p> <p>(c) One-way valve not installed properly</p> <p>(d) One-way valve in contact with other components</p>	<ul style="list-style-type: none"> - Replace the damaged one-way valve (refer to Disassembly) - Disassemble and clean the one-way valve (refer to Disassembly and Cleaning) - Make sure the one-way valve is seated properly - Make sure the one-way valve is not in contact with other components such as wire harness.

Table 1003 - Physical faults



**Component Maintenance Manual
443CH1**

PAGE INTENTIONALLY LEFT BLANK

DISASSEMBLY

1. Introduction

1-1. General

CAUTION: BATTERY DISASSEMBLY SHOULD ONLY BE PERFORMED ON A FULLY DISCHARGED BATTERY. REFER TO CHAPTER [Residual discharge](#) and [Cell shorting](#).

NOTE: Refer to [Testing and fault isolation](#) to identify possible causes of problems. This chapter gives the necessary level of disassembly to identify and correct possible issues.

The instructions found in this chapter are designed to allow the maintenance personnel to completely disassemble the battery for the purpose of General Overhaul. However, some maintenance operations do not require complete disassembly.

The figure and item numbers are those of the [Illustrated parts list](#).

1-2. Safety

Refer to chapter [Safety](#) for caution, risks, and proper personal protective equipments (PPE).

1-3. Job Set-up Information

1-3-1. Standard tools

Refer to chapter [Standard tools](#) in [Special tools, fixtures, equipment and consumables](#).

1-3-2. Special tools

When special tools are used in this chapter, they are identified by a code number listed in [Special tools, fixtures, equipment and consumables](#) chapter.

2. Disassembly of the battery

NOTE: All item numbers from the Illustrated Part List (IPL, Fig. 1) are referred by "(###)". Item numbers are linked by hyper-text to the IPL. Decimal of item numbers referred by "(###.#)" are for illustration aid only and are not listed in the IPL

2-1. Removal of the complete cover (020)

CAUTION: AVOID CONTACT BETWEEN THE COVER AND THE CELL TERMINALS OR LINKS.

- Undo the retaining latches
- Remove the battery cover complete (020)

2-2. Removal of the cells (180)

CAUTION: DO NOT PINCH CABLE HARNESS AGAINST SHARP EDGES.

NOTE: Make note of the proper placement of the links (110 to 170) and each cells in relation to one another before removal (per log book).

NOTE: To facilitate cell removal, remove the center cell in each row first.

- Remove cable ties (090)
- Remove the nuts (070) and the washers (080) that attach links to the cells
- Remove the stirrups (100)
- Remove all links (110 to 170)
- Fully screw the cell extractor tool T04 onto a cell terminal then pull up to remove the cells (180)

2-3. Remove the liner-spacer kit (240),

- Remove each liner-spacer (240) taking note the location, position, and count (refer to figure: [7003 - Liner-spacer kit](#))
- Remove the partition (250)

2-4. Remove the one-way valve (370)

- Remove the one-way valve (370) by gently pulling on the valve to remove it from the box.

2-5. Removal of the power connector (280)

- Remove the power connector cover (290) -if present-
- Remove the screws (260) with the washers (270)
- Remove the power connector (280) and the gasket (300)

2-6. Removal of the sensor connector (340)

CAUTION: CARE MUST BE TAKEN NOT TO PULL ON WIRES.

- Remove the sensor connector cover (345) -if present-
- Remove the screws (310), the washers (320) and the sensor nut plate (360)
- Remove the sensor connector complete (340) and gasket (350)

CLEANING

1. Introduction

The instructions in this chapter are for the general cleaning of your Saft aircraft battery. The instructions under "Light Cleaning" are to be done each time the battery is removed from the aircraft, and can be accomplished with no disassembly of the battery. The section "[Thorough cleaning](#)" includes the instructions for the cleaning of a disassembled battery for the purpose of a General Overhaul.

2. Safety

Refer to chapter [Safety](#) for caution, risks, and proper personal protective equipments (PPE).

3. Equipment

3-1. Standard tools

Refer to chapter [Standard tools](#) in [Special tools, fixtures, equipment and consumables](#).

3-2. Special tools

When special tools are used in this chapter, they are identified by a code number listed in [Special tools, fixtures, equipment and consumables](#) chapter.

3-3. Consumables

When consumables are used in this chapter, they are identified by a code number listed in [Special tools, fixtures, equipment and consumables](#) chapter.

4. Light cleaning

On an assembled battery.

CAUTION: DO NOT USE SOLVENT, PETROLEUM SPIRITS (SOLVENTS) OR OTHER PRODUCT CONTAINING CHLORIDE FOR CLEANING THE BATTERY. THE USE OF SOLVENTS CAN DEGRADE METAL AND PLASTIC PARTS.

NOTE: All item numbers from the Illustrated Part List (IPL, Fig. 1) are referred by "(###)". Item numbers are linked by hyper-text to the IPL. Decimal of item numbers referred by "(###.#)" are for illustration aid only and are not listed in the IPL.

4-1. Procedure

WARNING: TO PREVENT INJURY WHEN USING COMPRESSED AIR, POINT AIRFLOW AWAY FROM THE BODY. USE SAFETY GOGGLES TO PREVENT EYE INJURY FROM AIRBORNE PARTICLES.

- Remove the battery cover complete ([020](#))
- Check the battery vent tubes to make sure that they are clean and clear
- Finger tight the vent-valves ([230](#)) with the universal vent wrench [T01](#)
- Remove potassium carbonates (white deposits) from the top of all cells ([180](#)) using a stiff bristle, non-metallic brush
- Disperse residual salts and dust particles from the battery using blasts of clean, dry compressed air
- Coat all nuts ([070](#)), washers ([080](#)), stirrups ([100](#)), and links ([110](#) to [170](#)) with [M02](#)

5. Thorough cleaning

5-1. Procedure

Fully disassemble the battery (refer to [Disassembly](#) chapter).

5-1-1. Cells ([180](#))

CAUTION: DO NOT SOAK THE CELLS IN WATER.

Make sure that the vent-valve ([230](#)) is tight using the universal vent wrench [T01](#) according to [Fits and clearances](#).

Clean with warm water and a soft brush to easily remove all the electrolyte and mineral salts from the terminals, the cover and the sides of the cell cases.

Wipe the cell with a cloth and let dry.

5-1-2. Box (380), cover (020), and partition (250)

Clean with slightly soapy water [M03](#), wipe with a cloth and let dry.

5-1-3. Nuts, spring washers and links

Clean in slightly soapy water [M03](#) with a brush, rinse well with clean water and let dry.

5-1-4. Liner-spacer kit (240)

Clean in warm water and let dry.

5-1-5. Power connector (280)

CAUTION: DO NOT SUBMERGE THE POWER CONNECTOR

Wipe clean the power connector using damp cloth and let dry.

5-1-6. Sensor connector harness (340)

CAUTION: DO NOT SUBMERGE THE SENSOR CONNECTOR

CAUTION: CARE MUST BE TAKEN NOT TO PULL ON WIRES

Wipe clean the wire harness and heater using damp cloth and let dry.

5-1-7. Vent-valve

CAUTION: THE CLEANING OF THE VENT-VALVE MUST BE DONE WHEN THE CELLS ARE INSTALLED IN THE BOX.

CAUTION: VENT VALVES SHALL REMAIN INSTALLED ON THE CELLS WHEN EVER THE CELLS ARE NOT INSTALLED IN THE BATTERY BOX.

5-1-7-1. Removal of the vent-valve (230)

Remove the vent-valve (230) with the universal vent wrench [T01](#).

Cover cell vent-valve hole using a lint free cloth to prevent unwanted debris from entering the cell.

Soak vent-valves in distilled water [M01](#) for 30 min to 4 h to remove electrolyte salts from vent holes.

5-1-7-2. Installation of the vent-valve (230)

Make sure the vent-valves (230) are in good condition. Replace the vent-valves (230) if they are worn.

Install the vent-valve (230) with the universal vent wrench [T01](#) according to [Fits and clearances](#) chapter.

5-1-8. One-way valve (370),

CAUTION: IF THE ONE-WAY VALVE IS LOOSE, OR CRACKED, SHOWS SIGNS OF DAMAGES OR IF THE TAPE IS MISSING (FROM THE TOP OF THE VALVE), DISCARD THE VALVE AND REPLACE WITH NEW ONE.

Clean the on-way valve (370) in distilled water [M01](#), rub dry with a lint free cloth and let dry.

NOTE: The one-way valve (370) must not be soaked in the same solution as the vent-valves (230).

5-2. Lubrication

When the battery is clean (and after installation of the vent-valve), coat all upper nuts ([070](#)), washer ([080](#)), and links ([110](#) to [170](#)) with [M02](#).

INSPECTION/CHECK

1. Introduction

This chapter includes the checks, the maintenance procedures, and the functional tests that must be done to use Saft batteries in flight and on the ground.

NOTE: All item numbers from the Illustrated Part List (IPL, Fig. 1) are referred by "(###)". Item numbers are linked by hyper-text to the IPL. Decimal of item numbers referred by "(###.#)" are for illustration aid only and are not listed in the IPL.

2. Maintenance intervals

The aircraft manufacturer and / or operator is responsible for defining the usage and function, including maintenance intervals, for aircraft batteries installed in its aircraft. Saft only provides recommendations that requires the agreement of the aircraft manufacturer and / or operator.

NOTE: Maintenance steps should be completed in a battery shop.

Saft distinguishes between three types of maintenances: periodical check, regular check and general overhaul.

2-1. Periodical check

The periodical check essentially consists of voltage and insulation checks, discharge of residual capacity and charge with electrolyte level adjustment. The main purpose of this periodical check is to add water which is consumed by electrolysis during battery overcharge. It is normally applied between regular checks but can be omitted if the water consumption measured at the regular check is within allowable limits.

2-2. Regular check

The regular check is the same as the periodical check except that the battery is also deep-discharged ('balancing'), followed by a capacity check cycle.

2-3. General overhaul

The general overhaul is the same as the regular check except that the battery is also disassembled and thoroughly cleaned and inspected.

3. Recording

It is very important to record the battery check values (capacity, end of charge voltage, water consumption) for each cell as required in the battery logbook for each maintenance. It is recommended that an operator tracks these maintenance data in order to verify the interval is correct relative to that particular operation. This may also allow the interval to be extended if the data justifies it.

4. Safety

Refer to chapter [Safety](#) for caution, risks, and proper personal protective equipments (PPE).

5. Equipment

5-1. Standard tools

Refer to chapter [Standard tools](#) in [Special tools, fixtures, equipment and consumables](#).

5-2. Special tools

When special tools are used in this chapter, they are identified by a code number listed in [Special tools, fixtures, equipment and consumables](#) chapter.

6. Periodical check

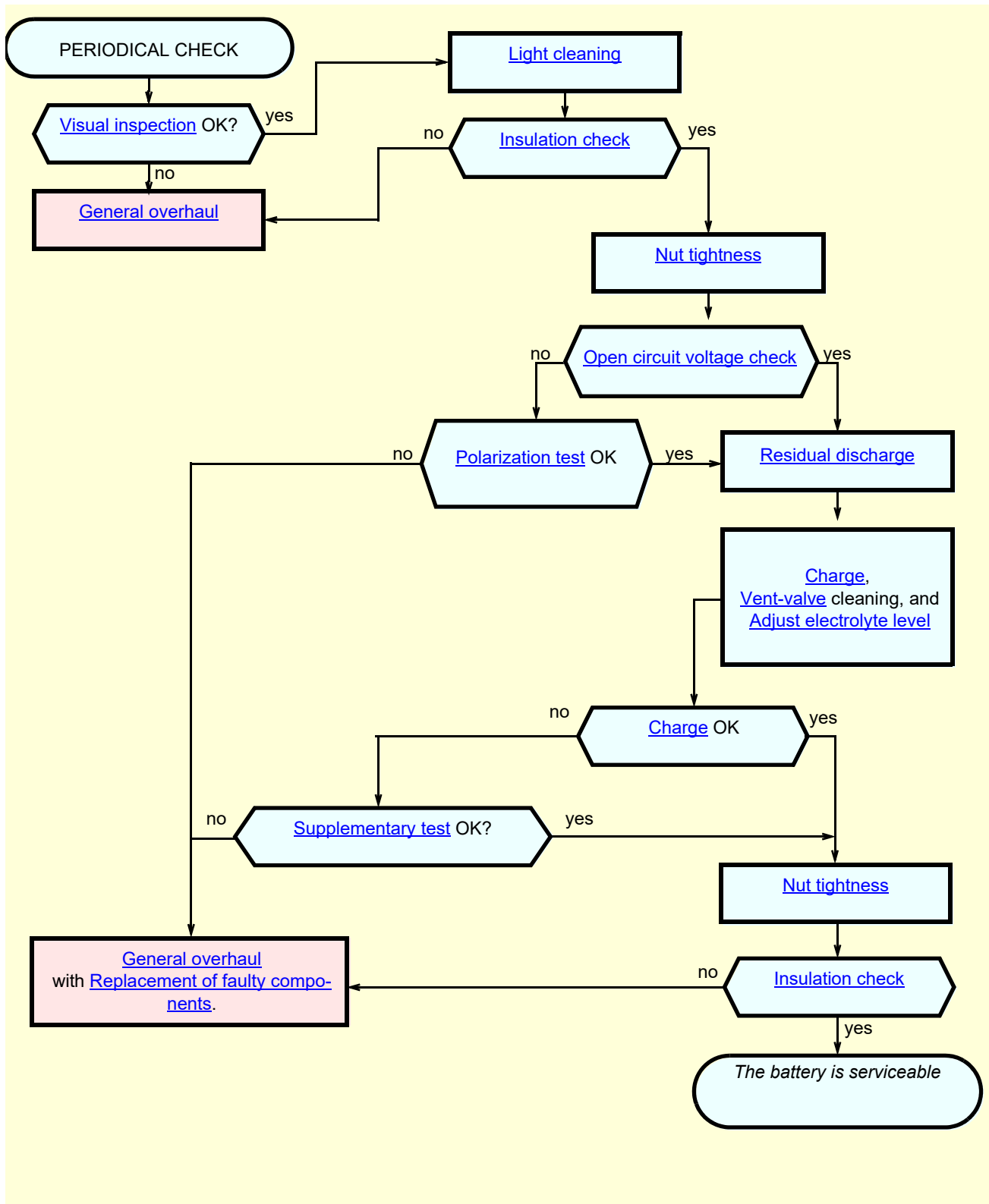

Figure 5001 - Periodical check

NOTE: Time periods are given as a guideline. Modify in accordance with operational experience. Periodic and Regular maintenance checks may be combined if operating hours permit.

At specific intervals according to aircraft use, or every 3 months, test the battery according to the above figure. Consult the airframe manufacturer for specific maintenance intervals or special procedures to be followed.

6-1. Visual inspection

CAUTION: WORN AIRCRAFT POWER CONNECTORS AND/OR LOOSE CONNECTIONS CAN GREATLY AFFECT THE PERFORMANCE OF THE BATTERY. A DEFECTIVE POWER CONNECTOR (280) CAN CAUSE OVERHEATING, BATTERY SELF-DISCHARGE AS WELL AS LOW VOLTAGE IN SERVICE.

Visual inspection should be done each time the battery is removed for maintenance from the equipment.

- Remove the cover (020)
- Visually check each cell (180) for evidence of electrolyte leakage. If OK proceed to [Light cleaning](#). If salt or traces of electrolyte is detected identify as NOT OK, proceed to [General overhaul](#). Excessive salt around terminal posts indicate possible leakage from the terminal O-ring. During [General overhaul](#), verify torque of the lower nut (190) (refer to chapter [Assembly](#)).
- Inspect the links (110 to 170), upper nuts (070), and washers (080). The hardware should be free of bends, tarnish, corrosion, burns, or any loss of nickel plating. Minor tarnish can be polished off with a fine wire brush. If OK proceed to [Light cleaning](#). If NOT OK proceed to [General overhaul](#) and replace defective hardware.
- Check the power connector (280) for evidence of arcing, corrosion, cracks, or cross-threaded terminals. If OK proceed to [Light cleaning](#). If NOT OK proceed to [General overhaul](#) and replace the defective power connector.
- Inspect the sensor connector complete (340) for bent or loose pins, corrosion, cracks, faulty wire connections, evidence of arcing, or cracked or loose potting material. If OK proceed to [Light cleaning](#). If NOT OK proceed to [General overhaul](#) and replace the defective sensor connector.
- Inspect the temperature sensor and blanket harness assembly for obvious damage. This in no way replaces the full testing procedures found hereafter which ensures full operation of the sensor assembly. If OK proceed to [Light cleaning](#). If NOT OK proceed to [General overhaul](#) and replace the defective sensor connector complete (340).
- Inspect the thermostat assemblies (as applicable) for any damaged or loose wire connections, cracks, dents, or other physical damage. If OK proceed to [Light cleaning](#). If NOT OK proceed to [General overhaul](#) and replace the defective sensor connector complete (340).
- Visually check all wiring insulation to ensure there is no evidence of cracks, cuts, or bubbling. If OK proceed to [Light cleaning](#). If NOT OK proceed to [General overhaul](#) and replace the defective sensor connector. Any evidence of damage to the temperature sensor and/or heater blanket harness assembly requires the sensor connector complete (340) replacement
- Inspect the battery box (380) and cover (020) for any damage. Make sure the cover gasket (040) is undamaged and fully secured to the cover (020). If OK proceed to [Light cleaning](#). If NOT OK proceed to [General overhaul](#) and replace the damaged box (380) or cover (020).

6-2. Insulation check

NOTE: A breakdown in electrical insulation between the cells (180) and the battery box (380) will result in a "leakage" current, which over time will discharge the battery.

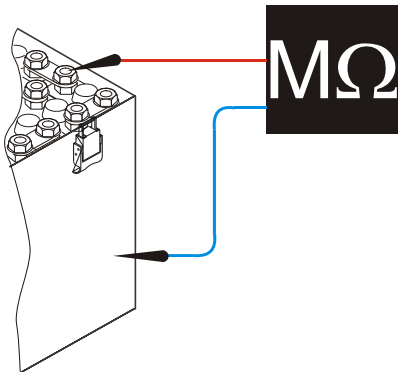

- Set the meg-ohmmeter to 250 V DC
- Measure the insulation between the positive terminal of each cells (180) and the battery box (380)
- Measure the insulation between the power connector (280) positive pin and the battery box (380)
- Measure the insulation between each pin of the sensor connector (340) and the battery box (380)

Refer to the table below for the acceptance criteria.

250 KΩ	2 MΩ	10 MΩ	
Do a General Overhaul Check cause(s) per Testing and fault isolation	Acceptable but Thorough cleaning is recommended	Acceptable for in service battery. For a new battery (direct from factory with no charge made by the customer) a Thorough cleaning is recommended	Mandatory level of insulation for new or in service battery after Thorough cleaning

Table 5001 - Acceptance criteria for insulation check

6-3. Nut tightness

Tighten and check the torque of all cell-terminals upper nuts (070) and power connector terminal nuts (070) (refer to [Fits and clearances](#)).

6-4. Open circuit voltage check

Measure the open circuit voltage of each cell (180). If all the cells are > 1.05 volt, continue with [Residual discharge](#). Otherwise, do a [Polarization test](#).

6-5. Polarization test

Charge the battery at [4.4 A](#) for 1.5 hours.

Leave the battery on open circuit for 1 hour.

Measure the open circuit voltage of each cell. If any cell is zero volt or has a negative polarity, do a [General overhaul](#) with [Replacement of faulty components](#). If all cells are above zero volt, continue with [Residual discharge](#).

6-6. Residual discharge

Discharge the battery at the [44 A](#) or [22 A](#) rate until each cell in the battery is discharged to 1.0 volt or below.

6-7. Adjust electrolyte level

WARNING: TAKE CARE NOT TO TILT CELLS WHILE VENT-VALVES ARE LOOSENED OR REMOVED. CONTACT OF ELECTROLYTE WITH SKIN CAN CAUSE BURNS (REFER TO CHAP. [Safety](#)). IF CONTACT OCCURS, FLUSH AREA WITH LARGE AMOUNTS OF WATER FOR 15 TO 30 MINUTES. ELECTROLYTE IN THE EYES IS VERY SERIOUS. FLUSH WITH WATER AND CONTACT A DOCTOR IMMEDIATELY.

CAUTION: USING ANYTHING OTHER THAN DISTILLED OR DEIONIZED WATER [M01](#) IN NICKEL-CADMIUM CELLS WILL CAUSE ELECTROLYTE CONTAMINATION AND IRREVERSIBLE DAMAGE TO THE CELLS.

CAUTION: THE BATTERY MUST BE FULLY CHARGED BEFORE ADJUSTING THE ELECTROLYTE LEVEL. USE ONLY DISTILLED OR DEIONIZED WATER [M01](#) (REFER TO CHAPTER [Special tools, fixtures, equipment and consumables](#)). DO NOT RE-USE WATER REMOVED FROM CELLS. THE VOLUME REQUIRED TO LEVEL THE FIRST CELL WILL SERVE AS A GUIDE FOR REQUIREMENTS OF THE REMAINING CELLS BUT THE AMOUNT OF WATER REQUIRED FOR EACH CELL CAN VARY, SO CARRY OUT THIS CHECK ON A CELL BY CELL BASIS. EACH CELL MUST BE LEVELED INDIVIDUALLY. IF THE QUANTITY OF WATER ADDED PER CELL IS ABOVE 80 % OF THE ELECTROLYTE WATER VOLUME SHOWN IN THE SPECIFICATION TABLES (REFER TO CHAPTER [Technical data](#)), CHECK THE CHARGING SYSTEM. IF IT IS FUNCTIONING PROPERLY, SHORTEN THE TIME PERIOD BETWEEN SERVICING.

CAUTION: THE MAXIMUM AMOUNT OF ADDED WATER IS [25 cm³ \(1.52 in³\)](#) per cell.

Always take appropriate precautions to prevent any foreign substances from entering the cell. Anything other than distilled or deionized water [M01](#) that enters the cells will cause electrolyte contamination and will affect overall performance.

The amount of time that the vent-valves (230) are removed from the cell (180) for maintenance should be limited to prevent as much air as possible from entering the cell. Carbon dioxide in the air will combine with the electrolyte to form potassium carbonate. Potassium carbonate will increase the internal resistance of the cells and thus decrease the performance at low temperatures and during high rate discharges. Always make sure that the vent-valves (230) are properly secured while the battery is in use.

Electrolyte level adjustment **must be done during the last 15-30 minutes** of the 4 hours overcharge at [4.4 A](#) rate of charge or last 15-30 minutes of the 5 hours at 0,1C₁ A or [4.4 A](#) for the supplementary test.

Adjust the level of electrolyte, one cell at a time, using the following instructions:

- 1. Remove the vent-valves (230) with its O-ring using the vent-valve wrench T01
- 2. Check the nozzle length before fitting it to the syringe (refer to para. Special tools for proper nozzle)
- 3. Insert the syringe T02 into the cell (180) opening until the shoulder of the nozzle rests on the vent-valve seat.

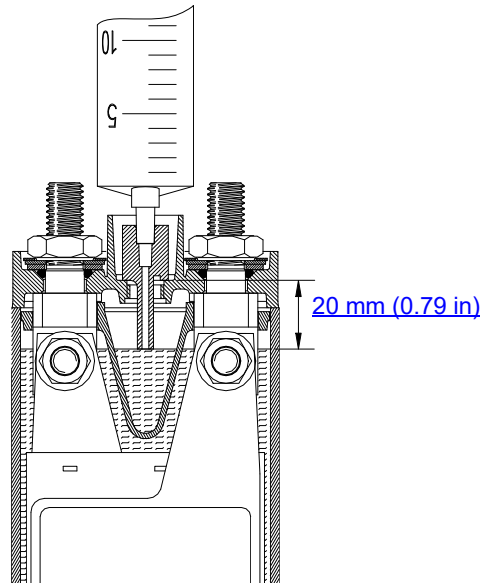

Figure 5002 - Position of syringe in cell vent seat

- 4. Withdraw the plunger and check for any liquid in the syringe. Any excess liquid in the cell will be drawn into the syringe until the electrolyte is level with the end of the nozzle. This is the correct level for the electrolyte.
If the liquid level is too low, the syringe will remain empty, indicating that the end of the syringe nozzle did not reach the liquid in the cell. In this case, replenish low electrolyte using distilled water M01.
- 5. Draw 5 cm³ (0.3 in³) of the distilled water M01 into the syringe and inject it into the cell and,
- 6. With the syringe nozzle remaining on the vent-valve (230) seat, slowly withdraw the plunger in the syringe one time again
- 7. If the syringe remains empty, repeat steps 5 and 6, counting the number of 5 cm³ (0.3 in³) injections required to achieve the correct level. Record the amount of water added to each cell on the maintenance record
- 8. At the point in step 6 when some excess liquid is drawn into the syringe, the correct level for that cell has been reached. Expel the excess liquid into a separate container for disposal. **Do not re-use the liquid removed from cells.** Check with local authorities for proper disposal of hazardous waste

6-8. Supplementary test

This test is used to confirm cell(s) fault(s):

- Continue to charge for an additional 5 h at 0.1C₁A or 4.4 A
 - The individual cell voltage (CVH441KH) must be ≥ 1.55 V per cell
 - [Adjust electrolyte level](#)
- If the voltage criteria is still not met within the 5h, replace the defective cell(s) (180). Follow [General overhaul](#)
- If cell(s) voltage(s) decreases by ≥ 0.03 V between the beginning and the end of the supplementary test, then replace the defective cell(s) (180). Follow [General overhaul](#).

NOTE: Cell voltage should be checked every 30 min. If the voltage criteria is reached before 5 h, you can stop the supplementary test.

7. Regular check

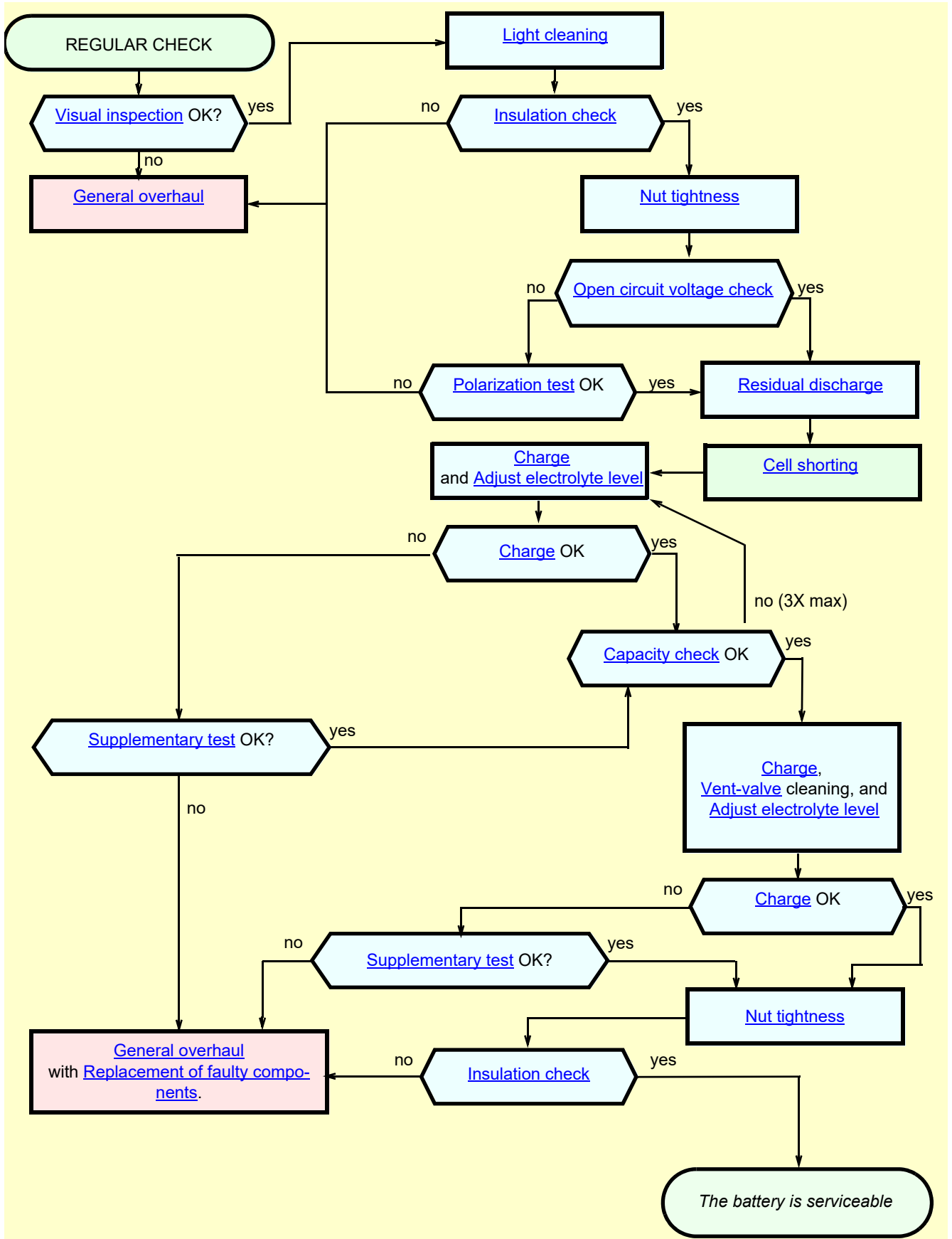

Figure 5003 - Regular check

Consult the airframe manufacturer for specific maintenance intervals or special procedures to be followed. Otherwise, at specific intervals according to aircraft use, or AFTER A MAXIMUM OF 6 MONTHS, test the battery according to figure [5003 - Regular check](#).

NOTE: Time periods are given as a guideline. Modify in accordance with operational experience. Periodic and regular maintenance checks may be combined if operating hours permit.

7-1. Cell shorting

As each cell's voltage drops below 1.0 V, connect an equalizing resistor [T03](#) across each cell terminals. Leave the resistors in position for 12 to 24 hours to allow each cell to completely discharge and the battery to cool.

NOTE: As an alternative to the resistor, a shorting clip can be applied when the voltage has dropped to 0.5 V per cell.

NOTE: It is suggested to use a low charge 0.1 C₁A or [4.4 A](#) rate after cell shorting.

7-2. Capacity check

This procedure is used to calculate the battery capacity. It can be done in 2 different methods.

NOTE: If the capacity check is not OK, do: [Charge](#), [Adjust electrolyte level](#), and [Capacity check](#) loop 3 times maximum. If capacity check is still not OK then follow [General overhaul](#) to replace defective cells.

7-2-1. Method 1

This method is suitable for devices that can record individual cell voltages and discharge current continuously over time.

- Discharge the battery at [44 A](#) and record the individual voltages of all cells
- Record the time when each cell falls to 1.0 V. Once the cell voltage falls between 0.5 V and 1.0 V, apply equalizing resistor [T03](#) across the low-voltage-cell terminals
- All cell voltages must be ≥ 1.0 V at [1 hour](#)

7-2-2. Method 2

This method is especially suitable for battery shop that manually records the voltage using a multimeter.

- Discharge the battery at [44 A](#) for [1 hour](#)
- Record the voltage of each cell at the end of [1 hour](#):
 - If the voltage of each cell is ≥ 1.0 V, then the capacity test is OK
 - If any cell voltage is < 1.0 V, the capacity test is NOT OK

8. General overhaul

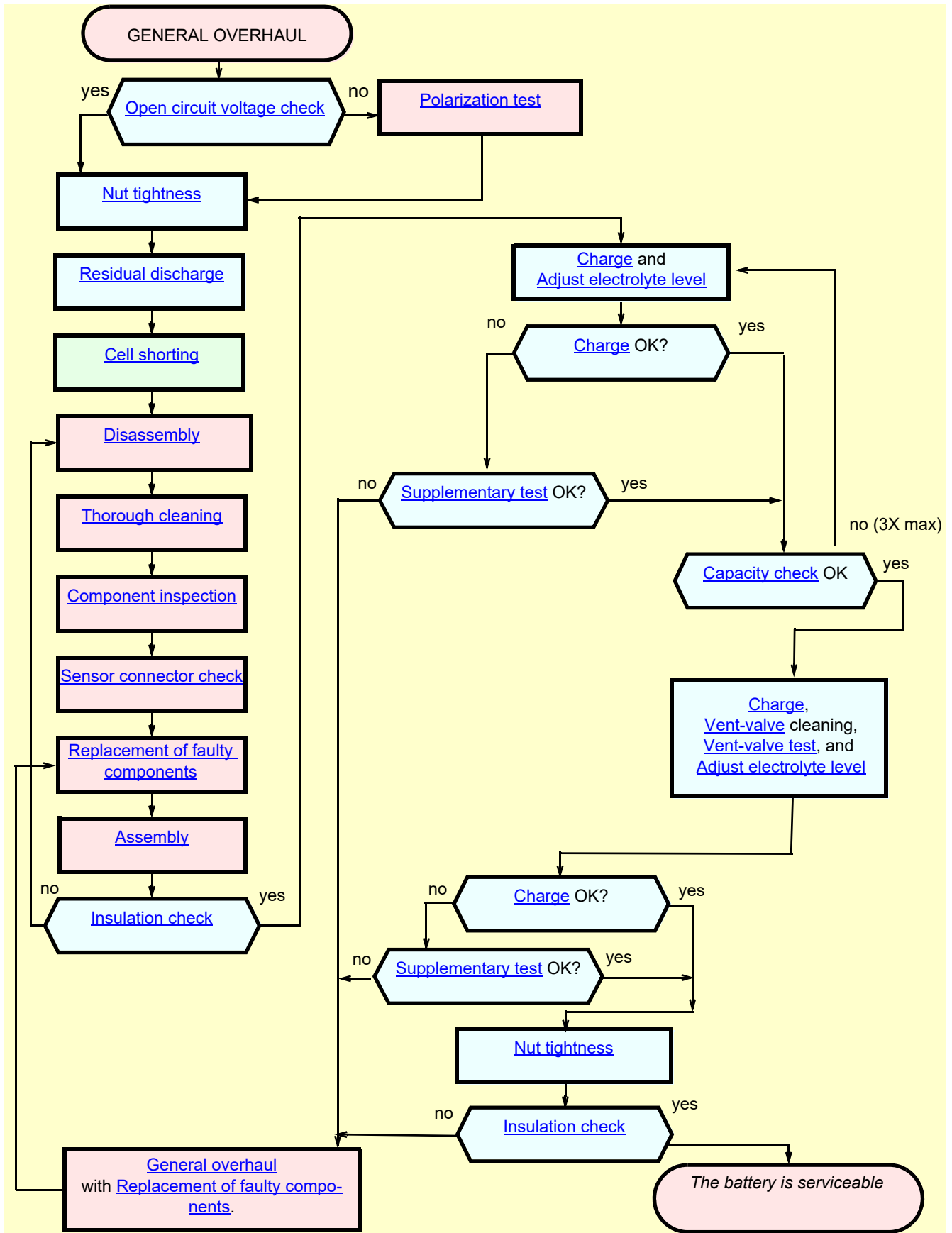

Figure 5004 - General overhaul

Consult the airframe manufacturer for specific maintenance intervals or special procedures to be followed. Otherwise, at specific intervals according to aircraft use, or AFTER A MAXIMUM OF ONE YEAR, test the battery according to the figure [5004 - General overhaul](#).

8-1. Component inspection

8-1-1. Cells (180)

Make sure that the lower terminal nuts (190) are tight (refer to [Fits and clearances](#) chapter).

Verify that cell-containers show no leakage.

8-1-2. Box (380)

Make sure the box (380) sides are straight.

8-1-3. Nuts (070), links (110 to 170), stirrups (100), and spring washers (080)

Discard components that show signs of corrosion or damage.

8-1-4. Power connector (280)

Check the power connector (280) for evidence of arcing, corrosion, cracks, or cross-threaded terminals. Replace the defective connector (280).

8-2. Replacement of faulty components

8-2-1. Cells - 3/5 cells rule

Saft strongly recommends to change all the cells or replace the complete battery if:

- One or more cells are found to be faulty and 5 of the original cells in the battery have been previously changed during the previous maintenance

or

- Three (3) or more cells are found to be faulty during the same maintenance

The 3/5 cells rule does not apply to the following failures:

- Mechanical failure such as terminal thread damage
- Cell leakage
- Cell short-circuit

NOTE: All cells to be replaced must be replaced by new Saft cells (180).

8-2-2. Other components

Any other components that are to be replaced must be replaced by new Saft components.

8-3. Sensor connector check

8-3-1. Insulation check

Make sure that the insulation between each pin of the sensor connector complete (340) and all metal parts of the sensor is > 10 MΩ @ 250 VDC

8-3-2. Sensor connector check

Do this test in a climatic chamber or equivalent device with the sensor connector complete (340) disassembled from the battery. Check the sensor connector according to the table below:

Check of	Between	Value
Thermistor T1	B-C	30 kΩ ± 2 kΩ @ +25 °C ± 2 °C (+77 °F ± 4 °F)
Thermistor T2	E-F	30 kΩ ± 2 kΩ @ +25 °C ± 2 °C (+77 °F ± 4 °F)
Insulation	Each pin of the sensor connector and all metal parts of the sensor	> 10 MΩ @ 250 VDC

Table 5002 - Sensor test

8-4. Vent-valve test

NOTE: The vent-valve test is not necessary if the full set of used vent-valves is replaced by a brand new one each year during the General Overhaul.

NOTE: Vent-valves should be cleaned before testing (refer to [Vent-valve](#) cleaning).

NOTE: If the vent-valve does not open during the test increase the pressure slowly until the vent-valve open (one time, to 1.4 Bar or 20 PSI max) to ensure functionality, then repeat the full test.

This test should be done while the battery is on charge.

Check the operation of the vent-valve assembly as follows:

- Install the vent-valve finger tight with its O-ring ([230](#)) into the vent-valve adapter [T05](#) of the pressure test fixture
- Immerse the vent-valve ([230](#)) in water and slowly raise the air pressure
- Test according to the table below, and change all vent-valves ([230](#)) that do not pass the test

Test	Check
O-ring	No distortion, split or cracks
air pressure < 0.14 bar (2 psi)	vent-valve is closed (no bubble)
0.14 bar (2 psi) < air pressure < 0.7 bar (10 psi)	vent-valve opens (bubbles observed)

Table 5003 - Vent-valve test

ASSEMBLY

1. Introduction

This section covers basic battery assembly procedures. In all cases, when reassembling a battery, all components should be clean and dry.

2. Safety

Refer to chapter [Safety](#) for caution, risks, and proper personal protective equipments (PPE).

3. Equipment

3-1. Standard tools

Refer to chapter [Standard tools](#) in [Special tools, fixtures, equipment and consumables](#).

3-2. Special tools

When special tools are used in this chapter, they are identified by a code number listed in [Special tools, fixtures, equipment and consumables](#) chapter.

4. Battery assembly

NOTE: All item numbers from the Illustrated Part List (IPL, Fig. 1) are referred by "(###)". Item numbers are linked by hyper-text to the IPL. Decimal of item numbers referred by "(###.#)" are for illustration aid only and are not listed in the IPL

4-1. Installation of the sensor connector assembly (330)

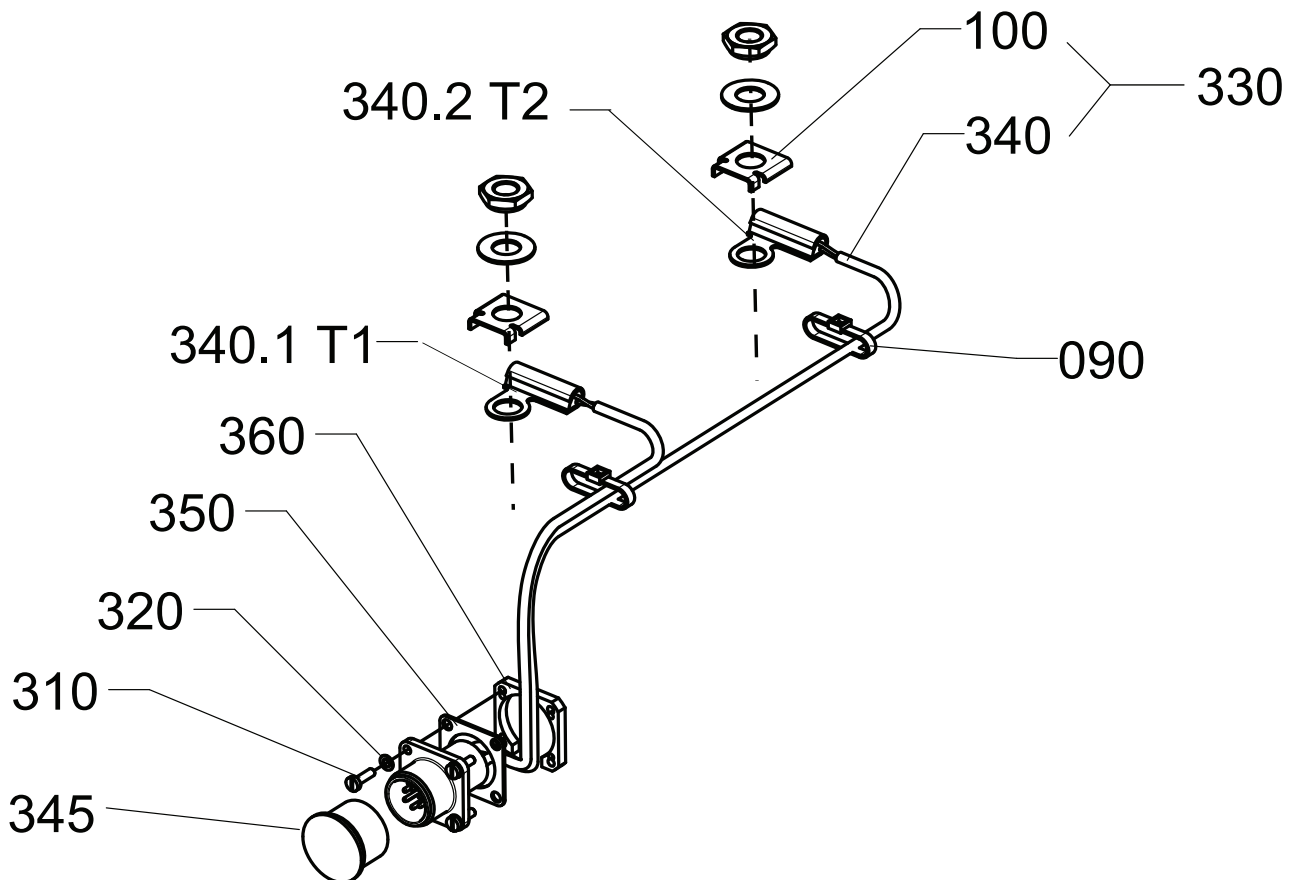

Figure 7001 - Connector sensor assembly

CAUTION: DO NOT PULL ON WIRES OR PINCH CABLE HARNESS AGAINST SHARP EDGES.

NOTE: Handle sensor connector complete (340) with care to prevent damage to the thermistor wires (340.1 and 340.2) refer to figure 7001 - Connector sensor assembly.

Install the connector of the sensor connector complete (340) and gasket (350) from outside the box (380) by threading the thermistors (340.1 and 340.2) -refer to figure 7001 - Connector sensor assembly- through the box (280).

Install the sensor connector nut plate (360) from inside the box (380).

From outside the box, screw the sensor connector complete (340) and gasket (350) using screws (310) and washers (320) onto the connector nut plate (360). Torque the screws (310) according to Fits and clearances chapter.

Set aside thermistor assembly (340.1 and 340.2) -refer to figure 7001 - Connector sensor assembly- while installing the liner kit (240) and cells (180) to prevent damage to the cables.

Install the sensor connector cover (345). -if available-

NOTE: Remove the sensor connector cover before flight.

4-2. Installation of the power connector (280)

Install the power connector (280) and gasket (300) from outside the box (380) into position with the screws (260) and the washers (270). Refer to figure 10001 - 443CH1 Nickel-Cadmium Aircraft Battery. Torque the screws (260) according to Fits and clearances chapter.

Install the power connector cover (290).-if available-

NOTE: Remove the power connector cover before flight.

4-3. Installation of the one-way valve (370)

CAUTION:THE ONE-WAY VALVE MUST BE INSTALLED, ORIENTED PROPERLY, AND MUST NOT TOUCH OTHER COMPONENTS; SENSOR CONNECTOR HARNESS OR METAL SPACER. REFER TO FIGURE (TBD).

Install the one-way valve (370) from inside the box (380) on the inside box vent tube.

Install the partition (250) inside the box (380) in front of the vent tube.

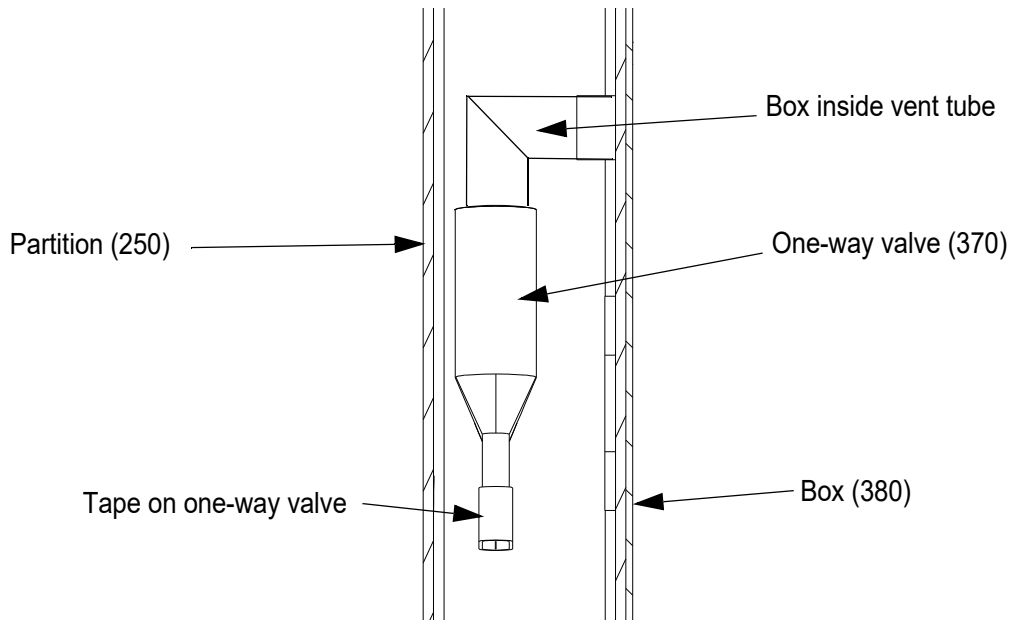

Figure 7002 - One-way valve installation

4-4. Installation of the liner-spacer kit (240)

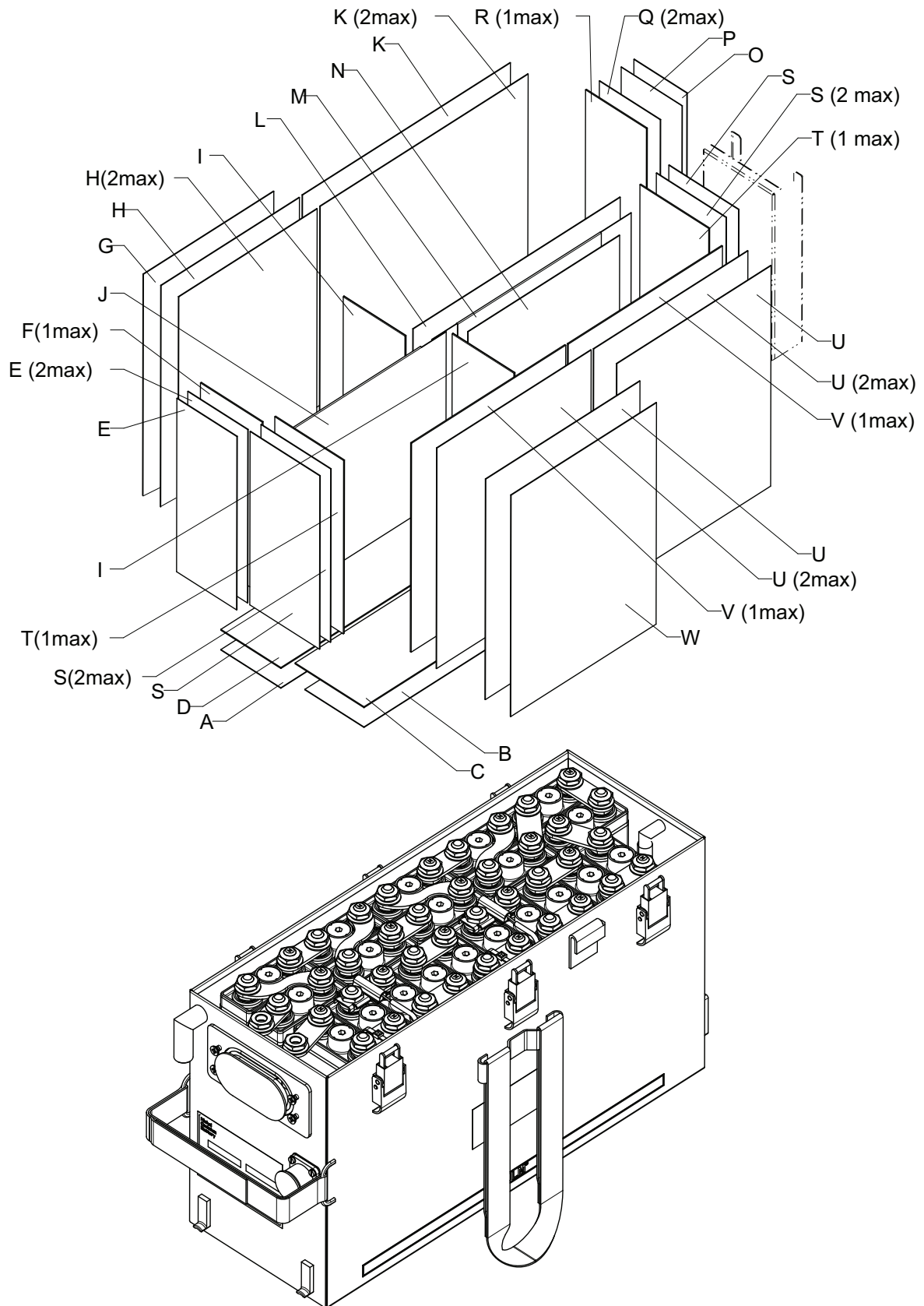

Figure 7003 - Liner-spacer kit

Item	Description	Dimension (mm)	Unit per assembly
A	Liner-spacer	0.5 x 395 x 68	1
B	Liner-spacer	0.5 x 350 x 67	1
C	Liner-spacer	1.0 x 350 x 78	1
D	Liner-spacer	1.0 x 395 x 68	1
E	Liner-spacer	0.5 x 180 x 68	3
F	Liner-spacer	1.0 x 179 x 70	1
G	Liner-spacer	0.5 x 148 x 230	1
H	Liner-spacer	0.5 x 157 x 230	3
I	Liner-spacer	0.3 x 332 x 70	1
J	Liner-spacer	0.3 x 186 x 342	1
K	Liner-spacer	0.5 x 236 x 230	3
L	Liner-spacer	0.5 x 185 x 235	1
M	Liner-spacer	0.3 x 226 x 342	1
N	Liner-spacer	0.5 x 172 x 185	1
O	Liner-spacer	0.5 x 230 x 60	1
P	Liner-spacer	0.3 x 69 x 230	1
Q	Liner-spacer	0.5 x 230 x 69	1
R	Liner-spacer	1.0 x 230 x 69	1
S	Liner-spacer	0.5 X 180 X 79	6
T	Liner-spacer	1.0 x 180 x 78	2
U	Liner-spacer	0.5 x 229 x 175	5
V	Liner-spacer	1.0 x 217 x 175	2
W	Liner-spacer	0.5 x 165 x 230	1

Table 7001 - Content of the liner-spacer kit

CAUTION: MAKE SURE LINER-SPACERS DO NOT OBSTRUCT THE BOX VENT PORTS.

NOTE: To facilitate liner-spacer kit (240) placement use cells (180) at both end of each rows.

NOTE: Liner-spacer kit (240) is used to make sure the cells (180) are tightly held in place. Adjust liner-spacer count as required.

Install the different liner-spacers (240) in position as illustrated by figure [7003 - Liner-spacer kit](#).

4-5. Cells installation (180)

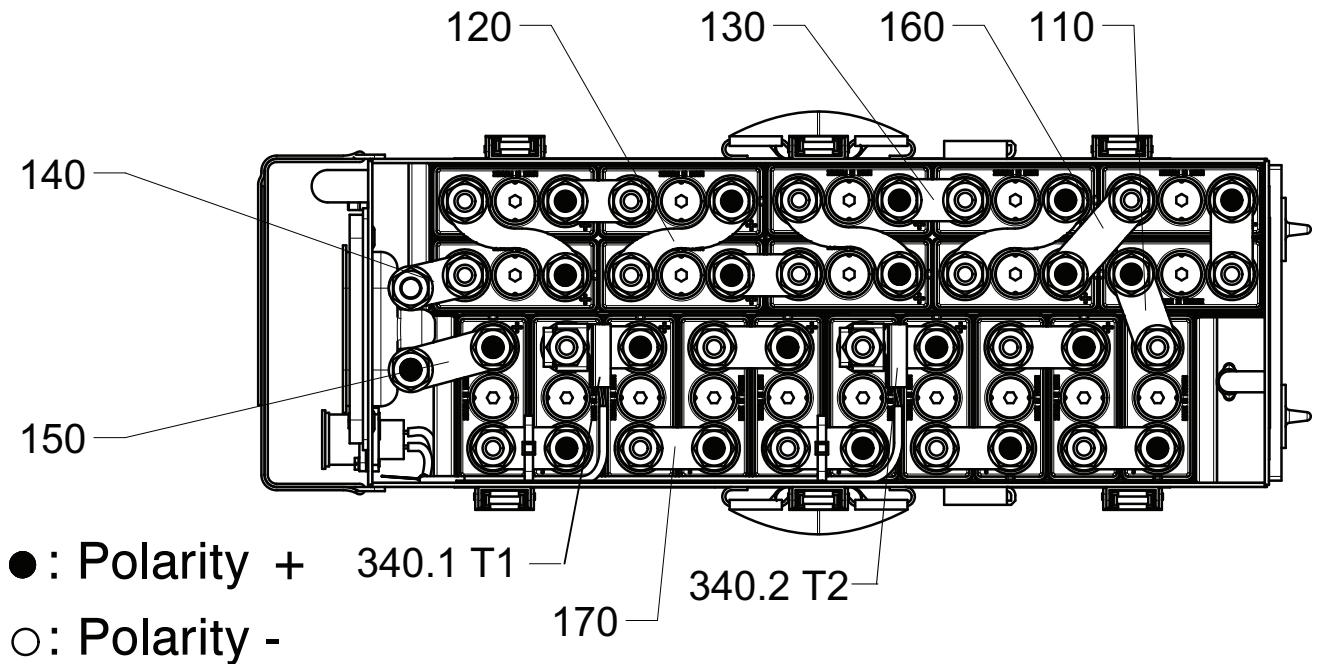

Figure 7004 - Battery layout

CAUTION: MAKE SURE CELL POLARITY IS CORRECT, DOUBLE CHECK CELL ORIENTATION TO FIGURE [7004 - Battery layout](#)

NOTE: To facilitate cell installation and make sure cell orientation is respected, first layout the cells outside the box per figure [7004 - Battery layout](#).

Install the remaining cells (180) starting from the end of each rows following the polarity orientation per figure [7004 - Battery layout](#).

Install the last cell into position by carefully pushing onto both cell terminals at once using a block of soft wood (if the cell insertion is too difficult, remove one or two liner-spacers).

Verify, once again, the polarity of each cells according to the figure [7004 - Battery layout](#).

Make sure that the cell terminals lower nuts (190) are torqued according to [Fits and clearances](#) chapter.

Lightly lubricate the cell terminals (180), nuts (070 and 190), the washers (080), stirrups (100), and the links (110 to 170) with [M02](#) (use a non-metallic paintbrush).

Install the links (110 to 170) on the cells (180) according to the figure [7004 - Battery layout](#).

Install the thermistors (340.1 and 340.2) with stirrups (100) according figure [7004 - Battery layout](#).

Install the washers (080).

Install the nuts (070). Torque the nuts (070) according to [Fits and clearances](#) chapter.

Lightly coat the nuts (070), the washers (080), and the stirrups (100) assembly with [M02](#) (use a non-metallic paintbrush).

Install the cable ties (090) making sure the cables are not pinched. Strictly respect the cable path illustrated in figure [7004 - Battery layout](#).

Install the cover complete (020) and attach it.

4-6. Recording

Fill out the log book (or equivalent).



**Component Maintenance Manual
443CH1**

PAGE INTENTIONALLY LEFT BLANK

FITS AND CLEARANCES**1. Introduction**

The torque values below are "lubricated torque" values.

Use [M02](#) to lightly grease the terminal and nut threads before assembly and torque.

Vent-valve should be finger tighten using Saft universal vent wrench [T01](#).

2. Torque table

IPL FIG ITEM N°	NAME	TORQUE VALUE	
		N.m	lbf.in
070	Upper nut, M10 x 1.25	12.0 to 14.0	106 to 124
190	Lower nut, M10 x 1.25	4.5 to 5.5	40 to 49
230	Vent-valve, M8	Finger-tight	Finger-tight
260	Power connector screw, M4 x10	2.0 to 2.5	18 to 22
310	Sensor connector screw, M3 x10	0.3 to 0.7	3 to 6

Table 8001 - Torque table



**Component Maintenance Manual
443CH1**

PAGE INTENTIONALLY LEFT BLANK

SPECIAL TOOLS, FIXTURES, EQUIPMENT AND CONSUMABLES

1. Introduction

This chapter is divided into two parts:

- The first part provides the list of special tools, fixtures and equipment needed to do the steps listed in the other chapters
- The second part provides the listing of consumables used in this manual

All listed items are identified in this manual by a standard code number:

- Txx for tools, fixtures and equipment
- Mxx for consumable materials

2. Standard tools

The following items are recommended to do the procedures described in this manual. When necessary, equivalent substitutes may be used.

- Safety gloves
- Protective goggles
- Safety shoes
- Eye wash
- Protective apron
- Constant current charger (DC current range 0-60 A, minimum open DC voltage 40 V)
- Constant current load bank (DC current range 0-60 A, DC voltage range 1-40 V)
- Meg-ohmmeter (0-50 MΩ @ 250 VDC)
- Multimeter (Volt, Ω, mA) 3.5 digits 2,000 counts 3.5 digits 1 % or better
- Climatic chamber if the battery has a sensor
- Torque wrench (insulated) 0-15 N.m (0-133 lbf.in)
- Standard mechanic's tools
- Stiff bristle brush (non-metallic)
- Small paintbrush (non-metallic)
- Dry, compressed air source [less than 1.4 bar (20 psi)]
- Soft, lint free, clean cloth (at least two required)

3. Special tools

NOTE: Equivalent tools can be used.

A special tool kit (P/N 416161) is available from Saft containing special tools including; T01, T02, T03, and T04. The tools are housed in a polypropylene box and each tool is insulated to make sure of optimum safety for the technician.

TOOL CODE	DESCRIPTION	(F6177) P/N	(V09052) P/N
T01	Universal vent wrench	413876	093365-000
T02	Syringe assembly with M8 , 20 mm (0.79 in) nozzle	416231 (assembly of 105112 & 016544)	020915-004
T03	1.2 Ω 3 W equalizing resistors	164829	-
T04	Universal cell extraction tool	416159	-
T05	Vent-valve testing adapter for M8 valve	458723	025098-000

Table 9001 - Special tools

4. Consumables

NOTE: Equivalent alternatives can be used for list items.

This paragraph describes the consumables used in the CMM.

MATERIAL CODE	DESIGNATION PART NUMBER AND SPECIFICATION	MANUFACTURER OR SUPPLIER (NAME, ADDRESS, CODE)
M01	<p>Distilled or deionized water (specification at 20 °C (68 °F)): clear, colorless and odorless while boiling Conductivity < 33 µS/cm 5 < pH < 7 Mn-COD < 30 mg/l (1.7 x 10⁻⁵ oz/in³) (Chemical Oxygen Demand under potassium permanganate methodology): methodology to evaluate organic or mineral pollution) Chlorines Cl- < 5 mg/l (2.9 x 10⁻⁶ oz/in³) Sulfates SO4-- < 10 mg/l (5.8 x 10⁻⁶ oz/in³) Temperature for analysis and specifications are at 20 °C (68 °F).</p> <p>STORAGE: dry and clean container without any corrosion and damage; Temperature: 20 °C ± 5 °C (68 °F ± 12 °F). Over 1 year of storage, do an analysis of the liquid.</p>	<p>Local vendor or in house production</p>
M02	<p>Neutral petroleum jelly Density @ 60 °C (140 °F) Range = 0.840 - 0.866 kg/l (0.486 - 0.500 oz/in³) Melting Point Range = 46 °C - 52 °C (115 °F - 126 °F) Acidity/Alkalinity = Neutral to Litmus</p>	<p>Mineral Vaseline NATO: S 743 F: AIR 3565 US: VV-P-236A UK: DEF 2333</p>
M03	Mild soap	Local vendor

Table 9002 - Consumable materials

ILLUSTRATED PARTS LIST

1. Introduction

1-1. General

The Illustrated Parts List (IPL) contains a list and illustrations of the assemblies and detailed parts of the unit in disassembly sequence.

To find the illustration for a part if the part number is known, refer to the [Alpha numerical index](#) and look for the part number and the corresponding figure and item number. Refer to the [Detailed part list](#) and look for the first figure and item number found in the [Alpha numerical index](#) for that part. If this figure shows the part in a section or system of the equipment other than the one necessary, refer to the other figure numbers listed in the Numerical Index.

To determine the part number of a given part, refer to the illustration showing the assembly including this part. Note the item number of the illustrated part and refer to the [Detailed part list](#) which indicates its part number and identification.

1-2. Alpha numerical index

In this index, part numbers are classified from left to right, each character (letter, number, hyphen) being considered separately. The part number column contains all part numbers included in the [Detailed part list](#).

1-3. Detailed parts list

1-3-1. Figure and item number

Each assembly, sub-assembly and parts with a part number that is included in the parts list is given as an item number.

The figure number linked to the item number is shown on the first line at the top of each page.

Numbered parts of assemblies and sub-assemblies included in the list but not illustrated are identified by a hyphen (-) preceding the item number.

An index letter shown before the item number refers to the figure showing the modified portion of the applicable part.

Manufacturer's Part Number: a manufacturer's part number is given to each assembly and detail part, whether illustrated or not.

Nomenclature: the nomenclature is given with an indenture, to show how the parts and the assemblies are related to the overall assembly. These are the details:

1 2 3 4 5 6 7

Assembly

. Detailed parts for assembly

. Sub-assembly

. Attaching parts and/or storage parts for sub-assembly

* * *

. . Detailed parts for sub-assembly

. . Sub-sub-assembly

. . Attaching parts and/or storage parts for sub-sub-assembly

* * *

. . . Detailed parts for sub-sub-assembly

The attaching parts are shown directly after the assembly of the part thereof. They are listed under the same indent number as the item they are attached to, are identified by the words "Attaching Parts" and are followed by three asterisks.

The manufacturer's code or the abbreviation NP (not procurable) are placed at the extreme right-hand side of the first line of the parts list column.

1-3-2. Effectivity code

A numerical index indicates the effectivity of sub-assemblies and detailed parts lists in relation to the next level assembly (ies) or sub-assembly (ies).

When the effectivity is fully applicable, the usage code column remains blank.

The use code for assemblies and detailed parts refers to the figure/item number of the next higher assembly (ies) or sub-assembly (ies). Example: Effectivity 1A, 1B, 1C is written 1ABC.

1-3-3. Units per assembly

The units per assembly column shows the quantity of units required for one next level assembly.

In some cases, the information is replaced by the abbreviation RF (for reference) or AR

2. Alpha numerical index

Part Number	Airline Stock Number	Figure Number	Item Number	Quantity per battery
MS90376-14R			345	1
012374			170	9
012521			160	1
012606			150	1
014184			130	3
015539			110	2
062007			190	82
100078			220	40
100094			210	82
100430			270	4
100431			260	4
100693			205	20
100694			200	20
100713			300	1
104960			320	4
116056			090	2
117026			390	1
164787			310	4
166309			440	2
166925			290	1
167712			350	1
167713			360	1
280068			430	1
411108			400	1
411691			120	4
412488			050	2
412662			100	2
413607			420	2
413609			410	2
413980			060	1
414470			180	20
415213			230	20
415690			370	1
416470			-001	RF
416471			010	1
416472			380	1
416475			020	1

Component Maintenance Manual 443CH1

Part Number	Airline Stock Number	Figure Number	Item Number	Quantity per battery
416557			340	1
416565			250	1
416580			330	1
416583			240	1
416613			140	1
416667			280	1

-: Item not illustrated

RF: For reference purpose

3. Detailed part list

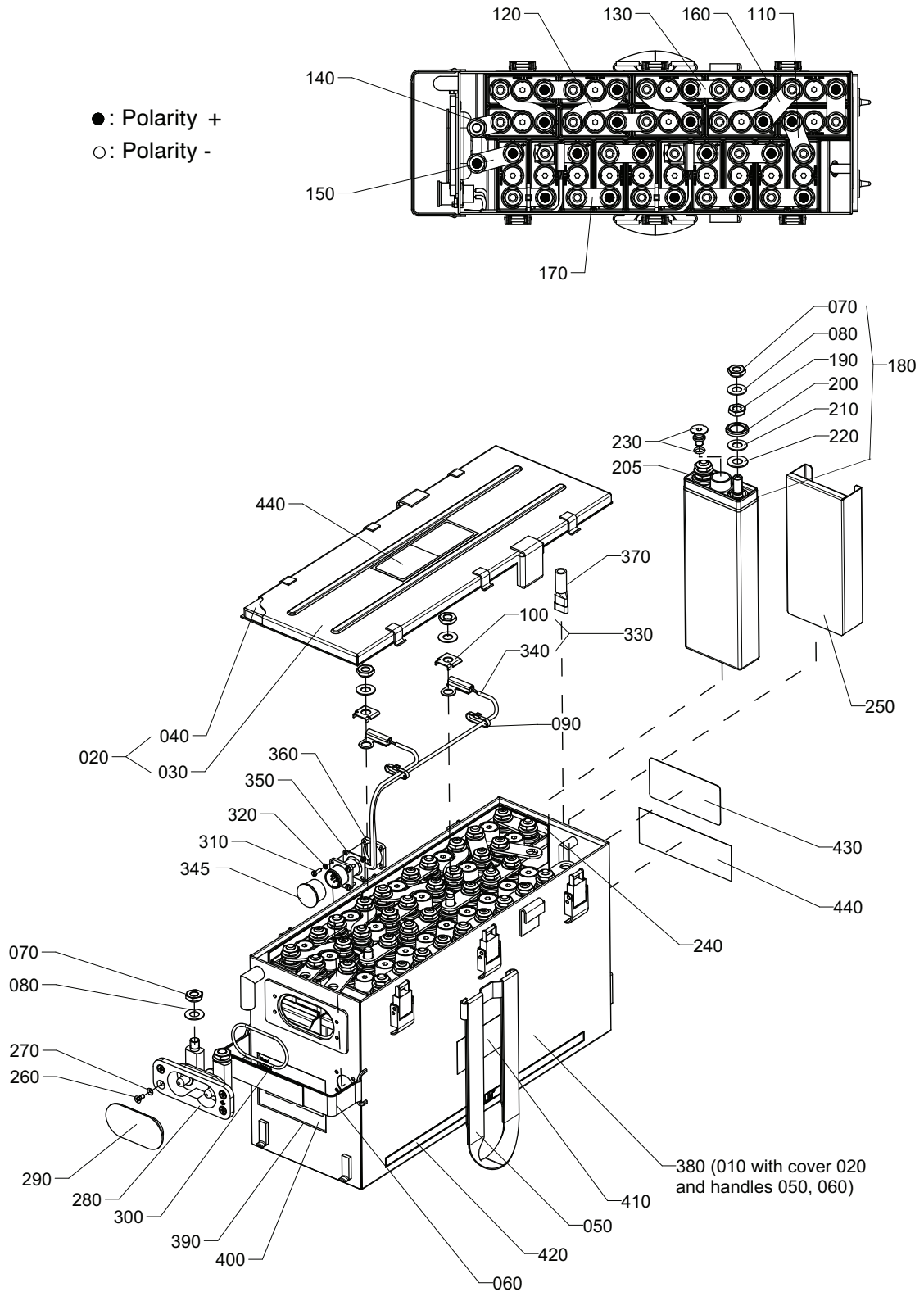

Component Maintenance Manual 443CH1

Figure Number	Item Number	Part Number	Airline Stock Number	Nomenclature							Unit per assembly
				1	2	3	4	5	6	7	
1	-001	416470		BATTERY 443CH1, with cells CVH441KH							RF
	010	416471		. Box and cover complete							1
	020	416475		. . Cover complete							1
	030	NP		. . . Cover assembly							NP 1
	040	NP		. . . Gasket cover							NP 1
	050	412488		. Handle side strap							2
	060	413980		. Handle side strap							1
	070	062007		. Nut, M10 X 1.25							42
	080	100094		. Spring washer							42
	090	116056		. Cable tie							2
	100	412662		. Stirrup							2
	110	015539		. Link inter-cell, E37							2
	120	411691		. Link inter-cell, curved							4
	130	014184		. Link inter-cell, E31							3
	140	416613		. Link inter-cell, E26							1
	150	012606		. Link inter-cell, E26							1
	160	012521		. Link inter-cell, E47							1
	170	012374		. Link inter-cell, E34							9
	180	414470		. Cell CVH441KH assembly							20
	190	062007		. . Nut, M10 X 1.25							2
	200	100694		. . Positive polarity washer							1
	205	100693		. . Negative polarity washer							1
	210	100094		. . Spring washer							2
	220	100078		. . Flat washer							2
	230	415213		. . Vent-valve							1
	240	416583		. Liner-spacer kit							1
	250	416565		. Partition							1
	260	100431		. Screw, M4 X 10							4
	270	100430		. Lock washer							4
	280	416667		. Power connector complete							1
	290	166925		. Power connector cover							1
	300	100713		. Power connector gasket							1
	310	164787		. Screw, M3 x 10							4
	320	104960		. Spring washer							4
	330	416580		. Sensor connector assembly							1

Component Maintenance Manual 443CH1

Figure Number	Item Number	Part Number	Airline Stock Number	Nomenclature							Unit per assembly	
				1	2	3	4	5	6	7		
	340	416557		.	.	Sensor connector complete						1
	345	MS90376-14R		.	.	Sensor connector cover				NP		1
	350	167712		.	.	Sensor connector gasket						1
	360	167713		.	.	Sensor connector nut plate						1
	370	415690		.	One-way valve							1
	380	416472		.	Box equipped							1
	390	117026		.	Protective film							1
	400	411108		.	Name plate label							1
	410	413609		.	Saft label							2
	420	413607		.	Range label							2
	430	280068		.	Recycling label							1
	440	166309		.	Filling instruction label							2

-. Item not illustrated

NP: Not Procurable

RF: For reference purpose



**Component Maintenance Manual
443CH1**

PAGE INTENTIONALLY LEFT BLANK

STORAGE (INCLUDING TRANSPORTATION)

1. Introduction

1-1. General

This document describes different methods of storage conditions recommended for a battery which has been cleaned and serviced and is not immediately placed in service on-board an aircraft.

Proper storage conditions and packaging makes sure that the equipment is protected against environmental damages.

1-2. Storage room

Keep the batteries and spares in a dry and clean room isolated from detrimental agents such as: dirt, dust, dampness, vibration, and corrosive atmosphere.

Lead-acid batteries must not be stored in the same room as Saft Ni-Cd batteries.

1-3. Climatic conditions

The recommended temperature range is $+20\text{ }^{\circ}\text{C} \pm 15\text{ }^{\circ}\text{C}$ ($+68\text{ }^{\circ}\text{F} \pm 27\text{ }^{\circ}\text{F}$).

Pressure 750 to 1060 hPa (22.15 to 31.3 in.Hg).

Relative humidity < 85 %.

2. Storage

2-1. Inactive long-term storage

2-1-1. Procedure

Before placing a battery into inactive long-term storage, the battery must successfully complete [Regular check](#) or [General overhaul](#) and be in a discharged condition (refer to [Residual discharge](#) and [Cell shorting](#)). There is no need of maintenance operation during the storage period. It is not necessary to short circuit the battery. No revalidation is required during the storage.

NOTE: If [Climatic conditions](#) are met and the packaging protects the battery from mechanical damages, environmental contaminants (i.e.: dirt, dust, vibrations, or corrosive atmosphere), and is airtight, then a 10 year storage period is allowed (if not airtight, a 2 year storage period is allowed).

The batteries are stored in a normal vertical position as described in paragraphs [Storage room](#) and [Climatic conditions](#).

2-1-2. Action at the end of long-term storage

For batteries under long-term storage and before installation of the battery into the aircraft for service:

- If storage time is less than or equal to 12 months, then do [Visual inspection](#), [Insulation check](#), [Nut tightness](#), [Charge](#), [Adjust electrolyte level](#), and repeat [Insulation check](#)
- If storage time is over 12 months do [Charge](#) followed by [Regular check](#)

2-2. Inactive standby storage

2-2-1. Scope

The inactive standby storage allows the battery to be stored in a "ready to be installed on the aircraft" condition.

2-2-2. Procedure

CAUTION: IF THE FOLLOWING CONDITIONS ARE NOT MET, THERE IS A RISK OF PLACING A BATTERY ON BOARD AN AIRCRAFT THAT DOES NOT MEET THE EMERGENCY REQUIREMENTS.

NOTE: The temperature is the average temperature during the storage period.

NOTE: If the battery was previously stored at a temperature below the ambient temperature, condensation may occur. Before installing do [Insulation check](#).

Maintain the battery per CMM procedures. Store the battery fully charged (refer to [Charge](#)) in a dedicated room (refer to [Storage room](#) and [Climatic conditions](#)) to be able to be installed in the aircraft without further check any time during an inactive standby storage period. The battery may be kept in inactive standby storage for a period of 90 days maximum corresponding to 80% available capacity (refer to figure [15001 - Standby storage period](#)).

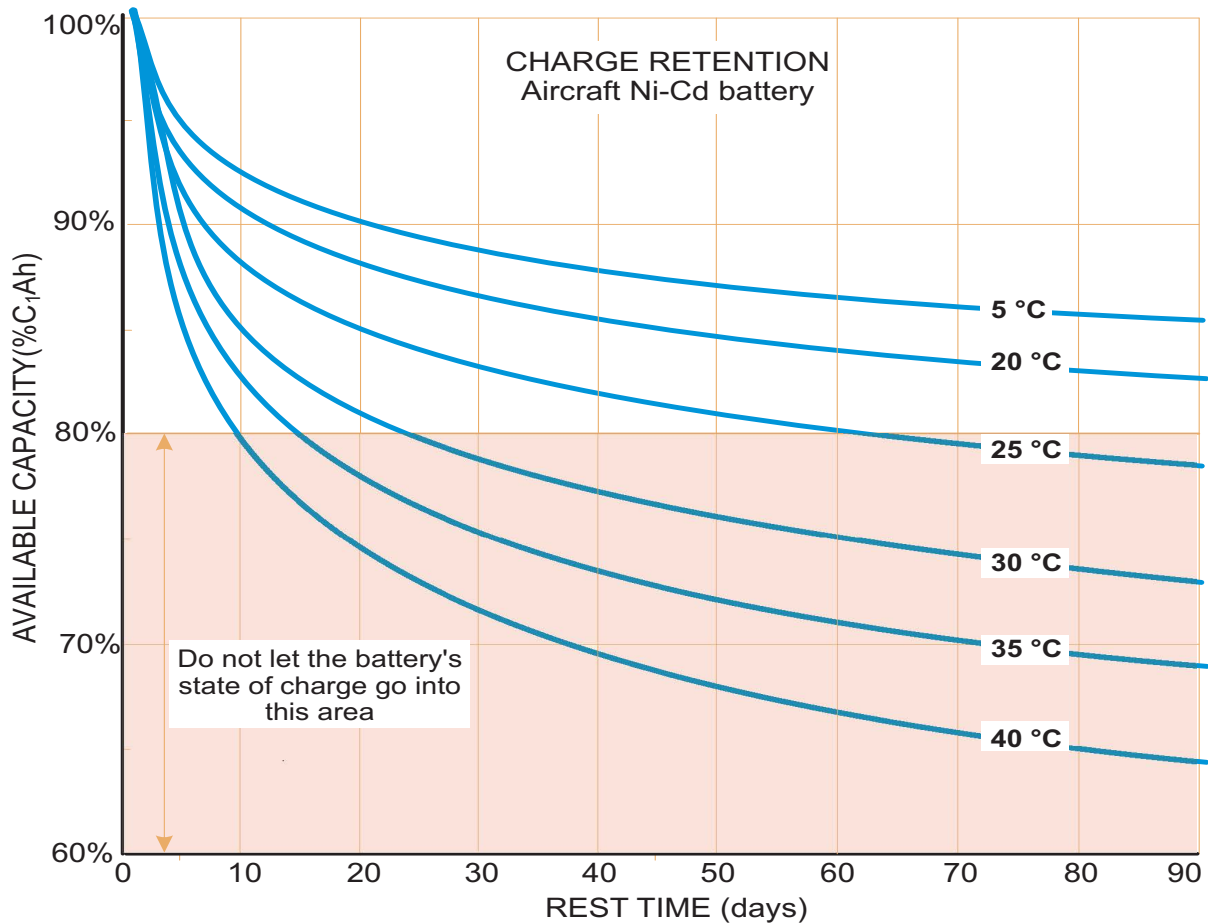

Figure 15001 - Standby storage period

2-2-2-1. Definitions

- The [Inactive standby storage](#) period is a maximum 90 days (3 months) for average room temperature < +23 °C (+73.4 °F)
- Total standby storage duration is 9 standby storage periods or 810 days (27 months)

2-2-2-2. Examples of standby storage period

- 24 days at an average room temperature of +30 °C (+86 °F)
- 60 days at an average room temperature of +25 °C (+77 °F)

2-2-3. Refresh charge

The [Inactive standby storage](#) period can be prolonged by applying refresh charge (at the end of the period). The refresh charge is defined as a short charge at 0.1C₁A, 0.5C₁A, or 1C₁A until the voltage reaches the values given in the Table [15002 - Inactive standby storage](#) below.

CHARGE rate	VOLTAGE (end of refresh charge)
0.1 C ₁ A or 4.4 A	1.50 V x 20 cells
0.5 C ₁ A or 22 A	1.55 V x 20 cells
1 C ₁ A or 44 A	1.57 V x 20 cells

Table 15001 - Charge rate for refresh charge

The battery can receive the refresh charge two (2) times maximum during each standby storage period. The time necessary to reach the required voltage should be very short. **Do not overcharge at 0.1C₁A for 4 hours.**

2-2-4. Action at the end of standby storage periods (refer to figure [15002 - Inactive standby storage](#))

NOTE: During any standby storage periods the battery is serviceable.

2-2-4-1. At the end of standby storage period 1, 2, 4, 5, 7, or period 8

- Do a [Refresh charge](#) and continue 1 more standby storage period
- Or install the serviceable battery into the aircraft without any further maintenance
- Or place the battery into [Inactive long-term storage](#) refer to the procedure

2-2-4-2. At the end of standby storage period 3 and period 6

- Install the serviceable battery into the aircraft without any further maintenance
- Or continue standby storage:
 - if the temperature is $\leq +30\text{ }^{\circ}\text{C}$ ($+86\text{ }^{\circ}\text{F}$), do [Insulation check](#) + [Residual discharge](#) + [Charge](#) + [Adjust electrolyte level](#) + [Insulation check](#) to continue [Inactive standby storage](#)
 - if the temperature is $> +30\text{ }^{\circ}\text{C}$ ($+86\text{ }^{\circ}\text{F}$) then do a [Regular check](#) to continue [Inactive standby storage](#)
- Or place the battery into [Inactive long-term storage](#)

2-2-4-3. At the end of standby storage period 9

- Install the serviceable battery into the aircraft without any further maintenance
- Or do a [Regular check](#) and place the battery into [Inactive long-term storage](#)

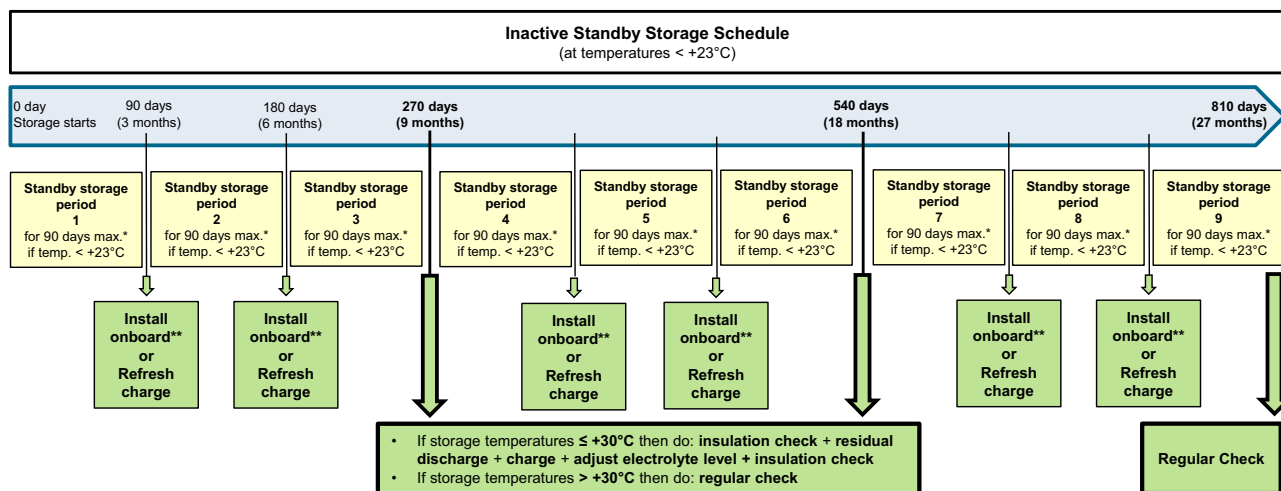

* If temperatures are $\geq +23^{\circ}\text{C}$ standby storage periods will be shorter, refer to Figure 15001

** The battery can be installed on board the aircraft at any time during the standby storage period

Figure 15002 - Inactive standby storage

2-2-4-4. Example (figure 15002 - Inactive standby storage)

NOTE: Standby storage period is shorter if the temperature is higher; refer to figure 15001 - Standby storage period to adjust the standby storage period duration based on average storage room temperature.

- The initial standby storage period @ $+20\text{ }^{\circ}\text{C}$ ($+77\text{ }^{\circ}\text{F}$) of a fully charged battery is 90 days (3 months) maximum without any other required operations the capacity will remain over 80% state of charge
- After 90 days (3 months) of storage @ $+20\text{ }^{\circ}\text{C}$ ($+77\text{ }^{\circ}\text{F}$), 1st [Refresh charge](#). An additional 90 days (3 months) of storage can then be added for a total duration of 180 days (6 months)
- After 180 days (6 months) of storage @ $+20\text{ }^{\circ}\text{C}$ ($+77\text{ }^{\circ}\text{F}$), 2nd [Refresh charge](#). An additional 90 days (3 months) of storage can then be added for a total duration of 270 days (9 months)
- At the end of standby storage period of 90 days (3 months) or 180 days (6 months) either:
 - Do a [Refresh charge](#) to continue 1 more standby storage period
 - Or install the serviceable battery into the aircraft without any further maintenance
 - Or place the battery into [Inactive long-term storage](#)
- At the end of standby storage period of 270 days (9 months) or 540 days (18 months) either:
 - Install the serviceable battery into the aircraft without any further maintenance
 - Or continue standby storage:
 - If the temperature is $\leq +30\text{ }^{\circ}\text{C}$ ($+86\text{ }^{\circ}\text{F}$) do [Insulation check](#) + [Residual discharge](#) + [Charge](#) + [Adjust electrolyte level](#) + [Insulation check](#) to continue [Inactive standby storage](#)
 - If the temperature is $> +30\text{ }^{\circ}\text{C}$ ($+86\text{ }^{\circ}\text{F}$) then do a [Regular check](#) to continue standby storage
 - Or place the battery into [Inactive long-term storage](#)
- At the end of standby storage period 810 days (27 months):
 - Install the serviceable battery into the aircraft without any further maintenance
 - Or do a [Regular check](#) and place the battery into [Inactive long-term storage](#)

3. Storage of spares

3-1. Spare Cells

Spare cells must be stored in a vertical upright position, filled, and discharged condition (electrolyte levels are not visible in discharged cells). It is not necessary to short circuit the cells. The vent-valves must be installed. The storage conditions are the same as those given in paragraph [Inactive long-term storage](#). No maintenance operation is needed during storage. Before installation in a battery, cells must be visually inspected for damage or leakage and cleaned and maintained as necessary in accordance with the battery CMM.

3-2. Spare O-rings, gaskets and vent-valves

3-2-1. O-rings and gaskets

Six (6) years of storage period starts from the date of manufacture unless otherwise specified on the packaging. The battery should be protected from exposure to the air, light, and high humidity < 85%. Storage life depends on temperature. It is recommended to store the parts in a cool area < +25 °C (+77 °F). Above +35 °C (+95 °F), storage life is reduced to 5 years. Before use the O-rings or gaskets must be inspected, in case of visible signs of damage, distortion or deterioration, the part must be discarded.

3-2-2. vent-valves with O-rings

Six (6) years of storage period starts from the date of manufacture unless otherwise specified on the packaging (the limitation is due to the O-ring). The battery should be protected from exposure of air, light and high humidity (< 85%). Storage life depends on temperature. It is recommended to store the parts in a sealed container (non-PVC) in a cool area < +25 °C (+77 °F). Above +35 °C (+95 °F), storage life is reduced to 5 years. Before use the O-rings must be inspected, in case of visible signs of damage, deformation or deterioration, the O-ring must be discarded.

3-2-3. Other spares parts

Other spare parts protected from external contamination (i.e. dirt, dust, dampness, vibration, corrosive atmosphere) and high humidity (> 85%), may be stored for unlimited periods. Before use, parts must be inspected. Parts showing any visible signs of damage, distortions, or deteriorations must be discarded.

4. Transportation procedure

The battery is normally discharged before packing. If it is necessary to transport a charged battery, make sure that the output terminals are protected against short circuit.

The battery should be packed vertically in its original container. If the original container is not available, the international and/or local packaging regulations applicable to the mode of transport and destination must be followed.

According to the IATA / IMDG dangerous goods regulations, Saft ships all existing nickel-cadmium batteries or cells for aircraft under the classification UN2795 (wet, filled with alkali).