



To: HOLDERS OF COMPONENT MAINTENANCE MANUAL 24-32-10 4017CH-3

Subject: CMM Revision No. 3 Dated Apr 11/2023

Replace revised pages by adding and removing pages for pages dated Apr 11/2023.

NOTE: The CMM can be downloaded from the internet at www.saft.com

HIGHLIGHTS

CHAPTER/SECTION PAGE NUMBER	DESCRIPTION OF CHANGE
Title Page T-1	Add Revision 3 with Date and update website
Record of Revisions ROR 1	Add revision 3
Service Bulletin List SBL 1	Updated information
List of Effective Pages LEP 1	Corrected/Changed pages
Introduction Intro 1	Clarification and website update
Introduction Intro 2, Intro 4	Update website
Testing and Fault Isolation 1002	Removed bracket
Testing and Fault Isolation 1003 -1004	Add vent valve O-ring information from repair sections
Testing and Fault Isolation 1005	Removed item from title
Testing and Fault Isolation 1006	Clarification for items removed from repair sections
Testing and Fault Isolation 1007, 1010 - 1012	Clarifications
Testing and Fault Isolation 1008	Remove duplicate information on table
Testing and Fault Isolation 1013	Relocated lower nut tightness from repair section.
Testing and Fault Isolation 1014, 1016	Corrected remedy
Disassembly 3001	Clarifications
Check 5001	Clarifications

24-32-10

Highlights Page 1 of 2

Apr 11/2023



CHAPTER/SECTION PAGE NUMBER	DESCRIPTION OF CHANGE
Repair 6001 - 6002	Clarifications and removed information on items covered under disassembly and assembly
Illustrated Parts List 10002	Updated website
Storage (Including Transportation) 15004 – 15005	Added storage of spare parts



ECCN: EAR99
CAGE Code 09052
711 GIL HARBIN INDUSTRIAL BOULEVARD
VALDOSTA, GEORGIA 31601
Phone: +1 (229) 247-2331 Fax: +1 (229) 247-8486

COMPONENT MAINTENANCE MANUAL

WITH ILLUSTRATED PARTS LIST

Nickel Cadmium Aircraft Battery

4017CH-3
P/N 024643-000

Website: www.saft.com

24-32-10

T-1
Rev 3 Apr 11/2023



COMPONENT MAINTENANCE MANUAL
4017CH-3

This document and all information contained herein are the property of Saft. Its use is restricted solely to the maintenance of Saft batteries and may under no circumstances be used for any other manufacturer's products. No person may, in whole or in part, duplicate, use or disclose this information for any other purpose without the prior written consent of Saft.

24-32-10

T-2
Mar 1/2022



COMPONENT MAINTENANCE MANUAL
4017CH-3

PAGE INTENTIONALLY LEFT BLANK

24-32-10

ROR 2
Mar 1/2022



COMPONENT MAINTENANCE MANUAL
4017CH-3

PAGE INTENTIONALLY LEFT BLANK

24-32-10

RTR 2
Mar 1/2022



COMPONENT MAINTENANCE MANUAL
4017CH-3

SERVICE BULLETIN LIST

SERVICE BULLETIN NUMBER / REV		DATE INCORPORATION OR NO EFFECT	TITLE
SB0516 / D	Jan 30/2023	No Effect	Inspection of latch clearances

24-32-10

SBL 1
Apr 11/2023



COMPONENT MAINTENANCE MANUAL
4017CH-3

PAGE INTENTIONALLY LEFT BLANK

24-32-10

SBL 2
Mar 1/2022



COMPONENT MAINTENANCE MANUAL
4017CH-3

LIST OF EFFECTIVE PAGES

SUBJECT	PAGE	DATE	SUBJECT	PAGE	DATE
TITLE PAGE	T-1	Apr 11/2023	DISASSEMBLY	3001	Apr 11/2023
	T-2	Mar 1/2022		3002	Mar 1/2022
RECORD OF REVISIONS	ROR 1	Apr 11/2023	CLEANING	4001	Oct 5/2022
	ROR 2	Blank		4002	Oct 5/2022
RECORD OF TEMPORARY REVISIONS	RTR 1	Oct 5/2022	CHECK	5001	Apr 11/2023
	RTR 2	Blank		5002	Oct 5/2022
SERVICE BULLETIN LIST	SBL 1	Apr 11/2023	REPAIR	6001	Apr 11/2023
	SBL 2	Blank		6002	Apr 11/2023
LIST OF EFFECTIVE PAGES	LEP 1	Apr 11/2023	ASSEMBLY	7001	Oct 5/2022
	LEP 2	Blank		7002	Mar 1/2022
TABLE OF CONTENTS	TOC 1	Mar 1/2022		7003	Mar 1/2022
	TOC 2	Blank		7004	Oct 5/2022
LIST OF ILLUSTRATIONS	LOI 1	Oct 5/2022	FITS AND CLEARANCES	8001	Mar 1/2022
	LOI 2	Blank		8002	Blank
LIST OF TABLES	LOT 1	Mar 1/2022	SPECIAL TOOLS, FIXTURES, EQUIPMENT, AND CONSUMABLES	9001	Oct 5/2022
	LOT 2	Blank		9002	Mar 1/2022
INTRODUCTION	Intro 1	Apr 11/2023	ILLUSTRATED PARTS LIST	10001	Mar 1/2022
	Intro 2	Apr 11/2023		10002	Apr 11/2023
	Intro 3	Mar 1/2022		10003	Oct 5/2022
	Intro 4	Apr 11/2023		10004	Oct 5/2022
DESCRIPTION AND OPERATION	1	Mar 1/2022		10005	Oct 5/2022
	2	Mar 1/2022		10006	Oct 5/2022
	3	Mar 1/2022		10007	Oct 5/2022
	4	Mar 1/2022		10008	Oct 5/2022
TESTING AND FAULT ISOLATION	1001	Oct 5/2022		10009	Oct 5/2022
	1002	Apr 11/2023		10010	Blank
	1003	Apr 11/2023	STORAGE (INCLUDING TRANSPORTATION)	15001	Mar 1/2022
	1004	Apr 11/2023		15002	Mar 1/2022
	1005	Apr 11/2023		15003	Oct 5/2022
	1006	Apr 11/2023		15004	Apr 11/2023
	1007	Apr 11/2023		15005	Apr 11/2023
	1008	Apr 11/2023		15006	Blank
	1009	Mar 1/2022			
	1010	Apr 11/2023			
	1011	Apr 11/2023			
	1012	Apr 11/2023			
	1013	Apr 11/2023			
	1014	Apr 11/2023			
	1015	Mar 1/2022			
	1016	Apr 11/2023			

24-32-10

LEP 1
Apr 11/2023



COMPONENT MAINTENANCE MANUAL
4017CH-3

PAGE INTENTIONALLY LEFT BLANK

24-32-10

LEP 2
Mar 1/2022



COMPONENT MAINTENANCE MANUAL
4017CH-3

TABLE OF CONTENTS

PARAGRAPH TITLE	PAGE
INTRODUCTION	Intro 1
DESCRIPTION AND OPERATION	1
TESTING AND FAULT ISOLATION	1001
AUTOMATIC TEST REQUIREMENTS (ATLAS)	N/A
DISASSEMBLY	3001
CLEANING	4001
CHECK	5001
REPAIR	6001
ASSEMBLY	7001
FITS AND CLEARANCES	8001
SPECIAL TOOLS, FIXTURES, EQUIPMENT, AND CONSUMABLES	9001
ILLUSTRATED PARTS LIST	10001
STORAGE (INCLUDING TRANSPORTATION)	15001



COMPONENT MAINTENANCE MANUAL
4017CH-3

PAGE INTENTIONALLY LEFT BLANK

24-32-10

TOC 2
Mar 1/2022



COMPONENT MAINTENANCE MANUAL
4017CH-3

LIST OF ILLUSTRATIONS

FIGURE	DESCRIPTION	PAGE
Intro 1	Universal Recycling Symbols	Intro 3
1	Nickel Cadmium Battery	1
1001	Process Flow for Battery Restoration	1002
1002	Connector Pinout	1005
1003	Position of T02 in Cell Vent Seal	1009
1004	Special Testing Flow Chart	1013
7001	Cell and Spacer Installation	7002
7002	Cell Number and Polarity Orientation	7003
7003	Sensor Harness Routing	7003
IPL Figure 1	Battery, Exploded View (#1 of 4)	10004
IPL Figure 1	Battery, Exploded View (#2 of 4)	10005
IPL Figure 1	Battery, Exploded View (#3 of 4)	10006
IPL Figure 1	Battery, Exploded View (#4 of 4)	10007
15001	Standby Period	15002
15002	Inactive Standby Storage Schedule	15003



COMPONENT MAINTENANCE MANUAL
4017CH-3

PAGE INTENTIONALLY LEFT BLANK

24-32-10

LOI 2
Mar 1/2022



COMPONENT MAINTENANCE MANUAL
4017CH-3

LIST OF TABLES

TABLE	DESCRIPTION	PAGE
1	Leading Particulars	2
1001	Sensor Harness Check Values	1005
1002	Initial Discharge (Off-wing Capacity)	1006
1003	Charge Table	1008
1004	Final Charge Voltage Limit	1008
1005	Capacity Check (Second Discharge)	1010
1006	Battery Faults	1011
1007	Cell Faults	1014
1008	Physical Faults	1015
8001	Torque Values	8001
9001	Special Tools	9001
9002	Consumables	9002
15001	Return to Service Following Storage	15001
15002	Refresh Charge	15003

24-32-10

LOT 1
Mar 1/2022



COMPONENT MAINTENANCE MANUAL
4017CH-3

PAGE INTENTIONALLY LEFT BLANK

24-32-10

LOT 2
Mar 1/2022



COMPONENT MAINTENANCE MANUAL
4017CH-3

INTRODUCTION

1. General

- A. This manual is written to the ATA Specification 100 and in ASD Simplified Technical English. International Standard units of measure are used in this manual, with imperial units in parentheses.
- B. This manual describes maintenance on components in a workshop. It does not describe maintenance on components when they are installed in aircraft.
- C. Only approved personnel with the necessary skills can do maintenance tasks described in this manual.
- D. This manual contains:
 - (1) Technical data for components
 - (2) Maintenance and replacement procedures for components
 - (3) An Illustrated Parts List (IPL) with data for parts of components. Parts are identified in all sections of the manual by IPL figure and item number.
- E. We make sure of DISASSEMBLY, TESTING AND FAULT ISOLATION, and ASSEMBLY procedures are correct by doing them.

The manual is divided into separate sections:

- (1) Title Page
- (2) Record of Revisions
- (3) Record of Temporary Revisions
- (4) List of Effective Pages
- (5) Table of Contents
- (6) Introduction
- (7) Procedures and IPL Sections

The disassembly and assembly sections contain only specific instructions used on the equipment covered herein. Most standard aerospace practices are not described herein.

This manual provides the information necessary for an experienced shop technician to maintain Saft nickel-cadmium batteries. It describes construction of the battery, as well as techniques used to operate, maintain, and provide care for the battery. Following these instructions will enhance the ability to obtain optimum performance and maximum life from Saft batteries.

All aircraft batteries require checking and maintenance to make sure they are safe when installed and they perform their required functions, especially in emergency conditions on-board the aircraft. Maintenance allows problems to be identified and corrected. The maintenance interval is the period for which correct operation is assured with a low probability of failure and allows elevated levels of MTBUR and MTBF.

Every effort has been made to provide complete and accurate instructions. If a situation arises that is not adequately described in this manual, please contact Saft via the internet at www.saft.com or at one of the following addresses:

24-32-10

Intro 1
Apr 11/2023



COMPONENT MAINTENANCE MANUAL
4017CH-3

Saft America, Inc. (09052)
711 Gil Harbin Industrial Boulevard
Valdosta, Georgia 31601, USA

Telephone: +1 (229) 247-2331
FAX: +1 (229) 247-8486

Saft (F6177)
26 quai Charles Pasqua
92300 Levallois-Perret, France

Telephone: +33 1 58 63 16 00
FAX: +33 1 58 63 16 18

2. Definitions

Warnings call attention to use of materials, procedures, or limits which must be followed precisely to avoid injury to persons.

Cautions call attention to procedures which should be followed to avoid damage to equipment.

Notes call attention to procedures which make the job easier.

3. Safety

WARNING: EXCEPT FOR THOSE STEPS THAT REQUIRE THE BATTERY TO BE CHARGED, DO ALL STEPS ON DISCHARGED BATTERIES (REFER TO [INITIAL DISCHARGE](#) AND [CELL SHORTING](#)) TO AVOID THE POSSIBILITY OF ELECTRIC SHOCK. TIGHTEN ¼ TURN VENT VALVES ([200](#)) USING [T01](#) PRIOR TO BEGINNING DISCHARGE. BATTERY CELLS DELIVER VERY HIGH CURRENT WHEN SHORT-CIRCUITED. EXERCISE CAUTION. REMOVE RINGS, WATCHES, NECKLACES, METALLIC BELTS AND OTHER JEWELRY TO AVOID ELECTRIC SHOCK.

WARNING: DO NOT TILT THE BATTERY DURING MAINTENANCE, ANY CONTACT OF SKIN WITH ELECTROLYTE CAN CAUSE SEVERE BURNS.

Safety rules differ from one country to another. Always follow local safety regulations.

There are three types of risks

A. Physical

- (1) Handling: the battery is heavy. When you lift it, bend your legs and not your back.
- (2) Use protective shoes.

B. Electrical

- (1) Do not wear rings, watches, chains, belt buckles, necklaces, or any other metallic objects.
- (2) Use insulated tools.

C. Chemical

- (1) For a complete listing of hazards, refer to the safety information sheet available on Saft's website at www.saft.com.
- (2) Electrolyte is very corrosive and can damage the skin: use gloves and an apron. If it touches the skin, flush affected part with large quantity of water. Remove contaminated clothing, after flushing begins.
- (3) Electrolyte is very dangerous for eyes, use protective goggles. If the electrolyte comes in contact with an eye, flush it with water and get immediate medical attention.

24-32-10

Intro 2
Apr 11/2023

COMPONENT MAINTENANCE MANUAL 4017CH-3

- (4) Saft recommends the use of an amphoteric solution (both acidic and basic behavior) and chelator (able to trap cations as a chelate complex) to neutralize electrolyte according to the local regulation.
- (5) Electrolyte ingestion can cause damage to the throat and respiratory tract. Do not try to vomit and get immediate medical attention.
- (6) Skin contact with nickel can cause chronic eczema.
- (7) Inhalation of cadmium oxide can cause dry throat, headaches, vomiting, chest pain. If inhaled, move to fresh air. If the affected person is not breathing, give artificial respiration. If breathing is difficult, give oxygen and get immediate medical attention.

4. New Battery Commissioning

Saft batteries are shipped discharged. All new Saft batteries that are receiving the initial commissioning within 12 months of the DOM refer to [Initial New Battery Commissioning](#) on page [5001](#) to place into service.

For all new Saft batteries that have not received an initial commissioning within 12 months of the DOM, then refer to [Servicing at end of long-term storage, Table 15001](#).

5. Battery Ratings

A. Capacity

Nickel-cadmium batteries are rated in terms of capacity in ampere-hours (Ah) (rated capacity).

Other definitions for battery ratings can be found in EN2570, IEC 60952, and RTCA DO 293.

6. Recycling

All batteries eventually lose their ability to perform and are eligible for scrapping and recycling. Saft takes environmental matters seriously and advocates proper recycling of nickel-cadmium batteries and their components. To that end, Saft operates recycling facilities in both Europe and North America.

Nickel-cadmium batteries contain nickel, cadmium, and potassium hydroxide and should be disposed of properly. In all cases, rely on local and national regulations for proper battery disposal and/or shipping to an appropriate recycling location.



Universal Recycling Symbols
Figure Intro 1



COMPONENT MAINTENANCE MANUAL
4017CH-3

You can find the nearest recycling collection point on our website at www.saft.com.

7. End of Life

EASA and FAA regulations “Part 145” requires end of life cells to be disposed of in a manner prohibiting them to be returned to service. Other authorities may have requirements less explicit, Saft recommends the following procedure to be followed to provide a means of compliance.

- A. Make sure the appropriate protective measures (refer to [Safety](#) paragraph and Battery Information Sheet (BIS)) are taken.
- B. Make sure the cell is fully discharged (See [Cell shorting](#)).
- C. Break or cut the terminals from the cell. If any electrolyte leakage occurs, make sure the clean-up measures as described in the Battery Information Sheet (BIS).
- D. Dispose of the cell in accordance with applicable transport, health and safety, and recycling regulations. (Refer to [Recycling](#) paragraph)

All batteries eventually lose their ability to perform and are eligible for scrapping and recycling. Saft takes environmental matters seriously and advocates proper recycling of nickel-cadmium batteries and their components. To that end, Saft operates recycling facilities in both Europe and North America.

8. Abbreviations

A	Amperes
ASD	AeroSpace and Defence Industries Association of Europe
ATA	Air Transport Association of America
EASA	European Air Safety Authority
FAA	Federal Aviation Authority
IATA	International Transport Air Association
IEC	International Electrotechnical Commission
IMDG	International Maritime Dangerous Goods
IPL	Illustrated Parts List
Max.	Maximum
MTBF	Mean Time Between Failure
MTBUR	Mean Time Between Unscheduled Removal
P/N	Part Number
RTCA	Radio Technical Commission for Aeronautics
V	Voltage

DESCRIPTION AND OPERATION

1. Description

The Nickel Cadmium Battery provides power to the standby system and/or to start the auxiliary power unit (APU). It is a nickel-cadmium type with a sintered plate positive electrode, and plastic-bonded negative electrode construction and uses a potassium hydroxide electrolyte. The battery consists of a case, cover, and 20 cells. The temperature sensor includes a thermostat and a thermosthich that are mounted to intercell links.

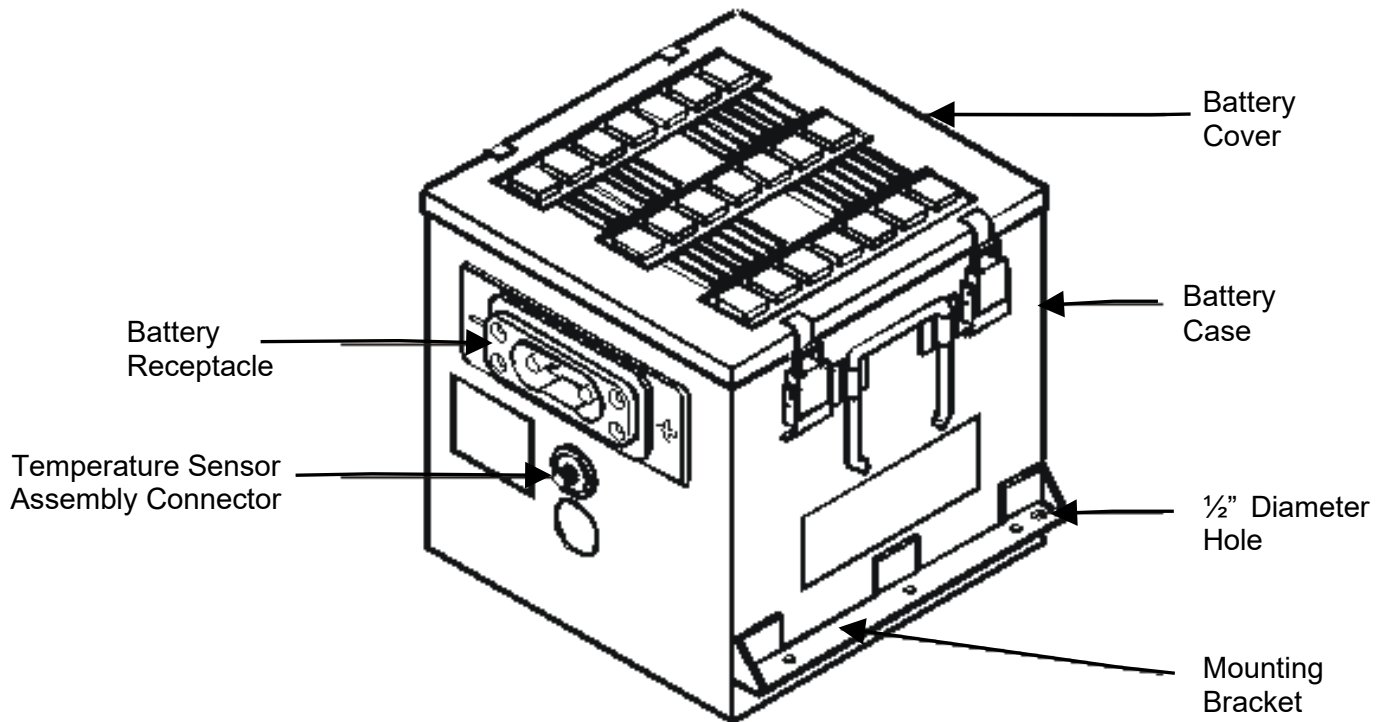

Nickel Cadmium Battery
Figure 1



COMPONENT MAINTENANCE MANUAL
4017CH-3

PARAMETER	VALUES
Voltage: Nominal	24.0 Volts
Weight	36.29 kg (80.0 pounds) maximum
Dimensions (Maximum): Height Length (including side brackets) Width (including handles)	257.79 mm (10.11 inches) 252.98 mm (9.96 inches) 304.80 mm (12.00 inches)
Cell Terminal	M10 X 1.25, externally threaded
Number of Cells	20
Cell Model	Saft-Type CVH400KA
1.0C ₁ A Rate	40.0A
0.5 C ₁ A Rate	20.0A
0.1 C ₁ A Rate	4.0A
Rated Capacity (C ₁)	40 Ampere-hours at 1.0C ₁ A
Maximum Consumable Water Reserve	70 cm ³ (4.27 in ³)
Venting valve	MS Style (¼ turn)
Venting Pressure	0.14 to 0.69 bar (2 to 10 psi)
Cell Case Material	Polyamide
Battery Case Material	Stainless Steel
Electrolyte	Potassium Hydroxide
Recommended Storage Temperatures	+5°C to +35°C (+41°F to +95°F)
Ambient Temperature	+15°C to +30°C (+59°F to +86°F)

Leading Particulars
Table 1

2. Operation

A. Flight charging

The battery is charged on the aircraft by an on-board charger. The thermostat will cut off the charger if the battery temperature exceeds a safe operating limit. It is also equipped with a thermostitch that can energize a heater if the battery temperature gets below optimum charging levels.



COMPONENT MAINTENANCE MANUAL
4017CH-3

B. Maintenance

(1) Maintenance interval basis

The aircraft manufacturer and/or operator is responsible for the definition of maintenance interval based on the use profile of the batteries installed on the aircraft. The maintenance interval has two main factors:

- Energy available for emergency requirements
- Electrolyte consumable reserve.

Both factors depend on the battery charging system, operating temperature, discharge magnitude, charge cycles, flight duration, ground operation, and battery technology.

The higher voltage per cell applied, the higher overcharge current and capacity the battery receives.

The overcharged capacity is directly related to the electrolysis of water from the electrolyte, and hence the consumption of the electrolyte reserve. For every 3 Ah of overcharge, 1 cm³ (0.06 in³) of water is consumed via electrolysis. Once the water reserve has been consumed, the result is:

- Dried out cells with a significant risk of permanent damage
- Internal short circuit
- Overheating
- Thermal runaway.

(2) Maintenance interval extensions

To validate maintenance interval extension, the recommendation is to have the Operator and Saft review the maintenance records for a minimum period of 12 months.

The data includes, but is not limited to, the recording of aircraft flight hours accrued while installed, its removal date, inspection date, off-wing capacity, and water consumption as required by this CMM.

As with any maintenance extension, subsequent monitoring of the water addition and electrical performance upon removal from the aircraft must be done to detect any adverse effects and, if necessary, re-adjust the maintenance interval accordingly. To determine the electrical performance more readily after aircraft removal, the battery may be floated 31V for 1.5 hours if the aircraft uses a dedicated charger or 28.5V for 1.5 hours if it floats on the aircraft bus before performing the Initial discharge (off-wing capacity) test.



COMPONENT MAINTENANCE MANUAL
4017CH-3

C. Battery data requirements

Maintenance information is required for any Saft battery evaluation to determine its condition and health. Throughout this manual there are multiple steps requiring specific information be recorded to maintain a battery service history. The information provided not will only reflect the batteries airworthiness, but also provide information to assist in any battery issue investigations required at the factory. As a minimum the items identified below are required for each battery maintenance step/action.

- (1) Record the date the battery was received, and time testing started.
- (2) As required for all discharges, record the duration the first cell reaches 1.0V.
- (3) As required during charges,
 - (a) Record the cell voltages at the start of the charge, at the end of the main charge, and the last 30 minutes of the final charge.
 - (b) Record the water added to each cell during the last 30 minutes of the final charge.
- (4) As required for special testing, record location and reason for cell replacement either voltage or capacity.
- (5) Record the date the battery is returned to service.



COMPONENT MAINTENANCE MANUAL
4017CH-3

TESTING AND FAULT ISOLATION

1. General

This section contains battery functional tests and fault isolation information. Test procedures are written in step-by-step formats that follow the process flow outlined in [Figure 1001](#). Fault isolation is presented in chart form to identify faults, possible causes, and remedies, refer to [Table 1006](#), [Table 1007](#), or [Table 1008](#).

NOTE: The () part identification numbers herein are [IPL Figure 1](#) item numbers.

NOTE: All voltage readings are DC unless otherwise stated.

2. Required Test Equipment

NOTE: Test equipment with equivalent specifications can be used.

Refer to [Special Tools, Fixtures, Equipment, and Consumables](#) for listing of Standard Tools.

3. Maintenance Procedures

In addition to the checks specified for airborne or ground use, in normal service SAFT 4017CH-3 batteries require the following maintenance operations.

A. Restoration Procedure

Outlined in [Figure 1001](#) is a step-by-step process flow required. A request for overhaul or restoration should follow this same procedure.

NOTE: Overhaul by some airworthiness authorities is defined as an item that has been disassembled, cleaned, inspected, repaired as necessary, reassembled, and tested. To identify this process the entire battery must require total disassembly, thorough cleaning, inspection, assembly, and testing.

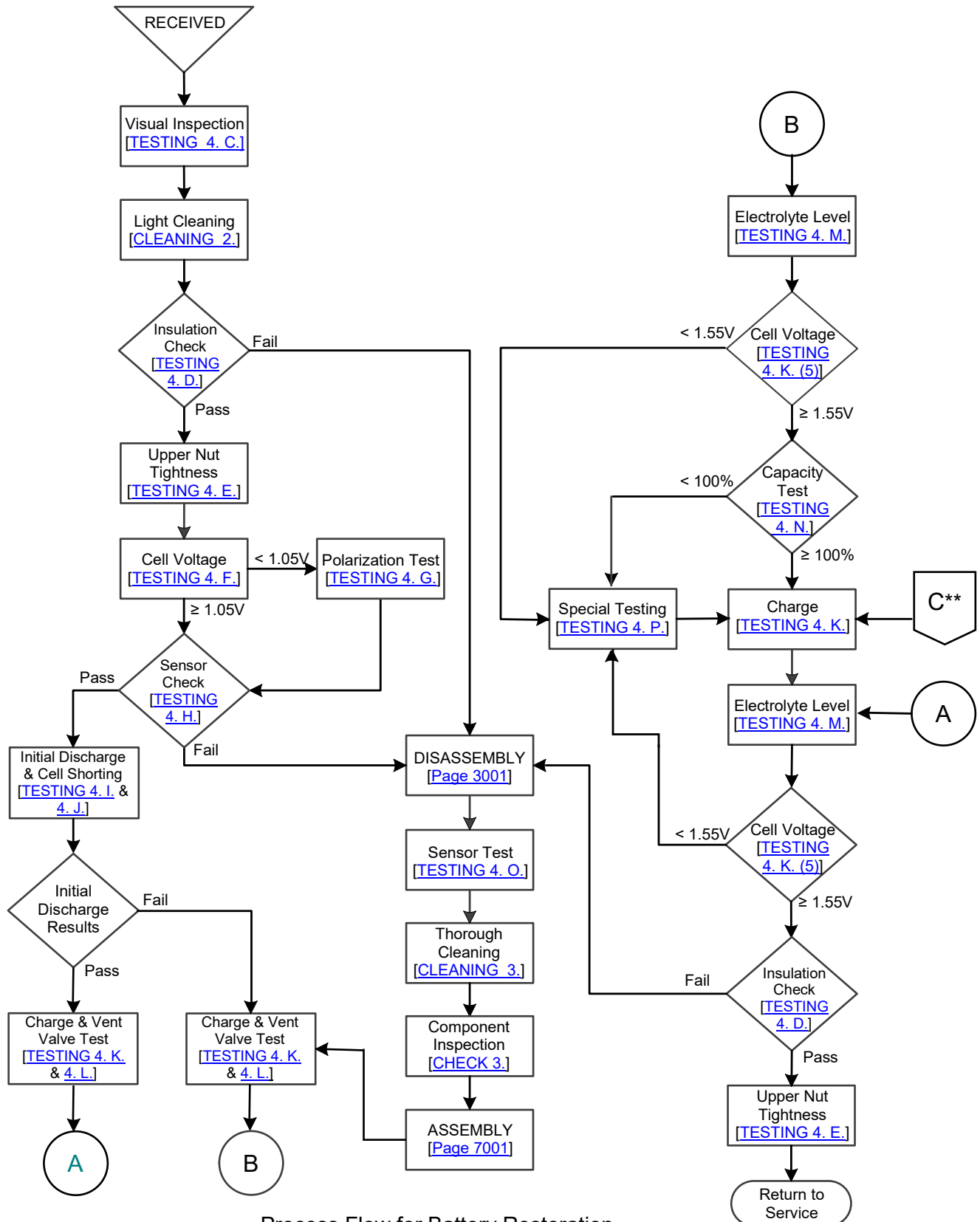

Process Flow for Battery Restoration
Figure 1001

**From [Table 15001](#)

24-32-10

1002
Apr 11/2023



COMPONENT MAINTENANCE MANUAL
4017CH-3

4. Testing

A. Test conditions

(1) Facilities and equipment

CAUTION: FUMES FROM LEAD ACID BATTERIES OR SMALL TRACES OF SULFURIC ACID ENTERING A NI-CD BATTERY CAN CAUSE PERMANENT DAMAGE.

- (a) Service facilities for Ni-Cd batteries must be entirely separate from those for lead acid batteries.
- (b) Equipment used to service lead acid batteries must not be used to maintain Ni-Cd batteries.

(2) For optimum results conduct all tests with the battery temperature at Ambient Temperature, unless otherwise noted in this manual.

B. Test equipment

Refer to [Special Tools, Fixtures, and Equipment, and Consumables](#) for test equipment recommendations.

C. Visual Inspection

Items found may require doing immediate disassembly while the majority do not. If a finding does not require going to disassembly procedure, then specific instructions are provided after the battery has been received its initial discharge.

- (1) Visually inspect battery cover ([020](#)) for dents, distortion, or other damage and replace as needed.
- (2) Visually inspect battery case ([010](#)) for dents, distortion, or other damage. If found, identify the component for replacement.
- (3) Visually inspect holddown pad ([030](#)) for distortion and other damage, replace as needed.
- (4) Visually inspect visible portions of each cell ([100](#) or [100A](#)) for any evidence of electrolyte leakage or damage.
 - (a) Damaged cells ([100](#) or [100A](#)) must be identified for replacement or further cleaning.

NOTE: Excessive electrolyte leakage will cause the battery to fail the Battery insulation test.

- (b) Excessive salts around the terminal posts gives an indication of possible leakage from terminal O-ring ([190](#) or [190A](#)). Identify any cells with excessive salts for later torquing the lower nut ([140](#)).
- (c) When inspection reveals electrolyte leakage from the cell at the vent hole opening, replace the defective O-ring ([210](#)).

WARNING: USE CARE NOT TO TILT CELLS WHILE VENT VALVES ARE OPEN OR REMOVED; CONTACT OF ELECTROLYTE WITH CAN CAUSE SEVERE BURNS.

- 1 Using [T01](#), loosen and remove the ¼ turn vent valve ([200](#)) from the cell ([100](#) or [100A](#)).

24-32-10

1003

Apr 11/2023



COMPONENT MAINTENANCE MANUAL
4017CH-3

- 2 Remove and replace defective O-rings (210) from the vent valve (200).
 - 3 Using T01, tighten the ¼ turn vent valve (200) onto the cell (100 or 100A).
- (5) Inspect the nuts (080), (110), (140), washers (090), (120 or 120A), (170 or 170A), and (180), and links (220 through 260) to ensure it is free of bends, tarnish, corrosion, burns, or loss of plating. Minor tarnish can be polished off with a fine wire brush. Identify any defective components for later replacement.
- (6) Check all ventilation openings to make sure that they are clean and clear.
- (7) Inspect the power connector (280) pins for defects, evidence of arcing or excessive oxidization. If observed, identify the power connector (280) for later replacement.

D. Battery insulation

NOTE: A breakdown in electrical insulation between the cells and the battery case will result in a “leakage” current, which, over a period of time, can discharge the battery.

NOTE: Method A or B may be used to check the insulation breakdown.

(1) Method A

- (a) Set up the multimeter and meter leads for a measurement of 250mA.
- (b) Connect the negative lead from the meter to the battery container then touch the positive lead from the meter to:
 - 1 the positive terminal of each cell.
- (c) If there is a reading of zero, the insulation test is a “Pass”; otherwise, the insulation test is a “Fail”.

NOTE: If, after cleaning the battery and assuring that everything is dry, a leakage current is still indicated by a reading other than zero, then one or more cells (100 or 100A) is defective. Isolate and replace the defective cell(s).

(2) Method B

- (a) On a completely assembled battery using megohmmeter under a continuous 250V, measure the insulation resistance between the metal box and
 - 1 the positive terminal of each cell.
- (b) The value measured must be $\geq 10\text{M}\Omega$ while under continuous 250V.
- (c) If the reading meets the above criteria ($\geq 10\text{M}\Omega$), the insulation is a “Pass”; otherwise, the insulation test is a “Fail”.

NOTE: If, after cleaning the battery and assuring that everything is dry, the resistance is still $< 10\text{M}\Omega$, one or more cells (100 or 100A) is defective, isolate and identify for later replacement.

E. Upper nut tightness

Check the tightness on each upper nut (080), (110) per [Table 8001](#).

F. Cell voltage

Measure and verify the voltage of each cell ([100](#) or [100A](#)) is greater than or equal to 1.05V.

G. Polarization test

- (1) Charge the battery at 0.1C₁ for 1.5 hours.
- (2) Keep the battery in open circuit for 1 hour.
- (3) Measure the open circuit voltage of each cell ([100](#) or [100A](#)).
 - (a) Identified for replacement any cell ([100](#) or [100A](#)) with zero volts or negative polarity. If any cell ([100](#) or [100A](#)) is identified for replacement, the polarization test is a “Fail”.
 - (b) If all cells are above zero volts, the polarization test is a “Pass”.

H. Sensor harness check

WARNING: A FULLY ASSEMBLED BATTERY MUST BE IN A FULLY DISCHARGED CHARGE STATE TO PREVENT INJURY, REFER TO [CELL SHORTING](#).

- (1) If any part of the harness ([040](#)) is damaged, the entire assembly must be replaced with new Saft sensor harness ([040](#)).

NOTE: A climate chamber or alternate methods may be used provided the temperatures below are achieved.

NOTE: Refer to [Figure 1002](#) for pinout locations.

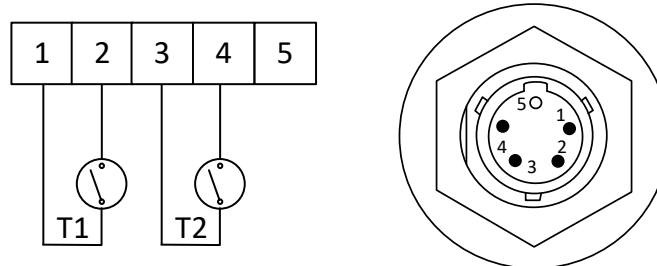

Connector Pinout
Figure 1002

- (1) If any part of the sensor harness ([040](#)) is damaged, the entire assembly must be replaced after disassembly.
- (2) Be sure the internal battery temperature is at +22.8°C ± 5.0°C (+73°F ± 9°F). Test with an ohmmeter per [Table 1001](#) on connector sensor harness ([040](#)). Any erratic or incorrect readings represents a failure and the entire assembly ([040](#)) must be replaced after disassembly.

ITEM	PINS	VALUES @ +22.8 +/- 5.0°C (+73 +/- 9°F)
T1	Pin 1 – 2	≥ 20MΩ
T2	Pin 3 – 4	≥ 20MΩ

Sensor Harness Check Values
Table 1001



COMPONENT MAINTENANCE MANUAL
4017CH-3

I. Initial discharge (off-wing capacity)

The purpose of this procedure is to discharge the battery to a known state of charge and determine the battery capacity from the aircraft.

- (1) Using [T01](#), verify the ¼ turn vent valve ([200](#)) is installed on each cell ([100](#) or [100A](#)).
- (2) Discharge the battery at a rate listed in [Table 1002](#) until the battery reaches 20.0V and record the times the first cell reaches 1.0V and battery reaches 20.0V.

NOTE: It is important that the discharge current be continually maintained at the selected value, and that the time of discharge be measured accurately.

NOTE: If a cell goes to zero volts or reverses polarity during the discharge, short out the cell's terminals for the remainder of the discharge.

DISCHARGE		MINIMUM TIME FOR FIRST CELL TO 1.0V
RATE (C ₁)	CURRENT (AMPS)	
0.5	20.0	122.0 MINUTES
1.0	40.0	60.0 MINUTES

Initial Discharge (Off-wing Capacity)
Table 1002

- (3) If defective case ([010](#)), power connector ([280](#)), nuts ([080](#)), ([110](#)) and washers ([090](#)), ([120](#) or [120A](#)), or links ([220](#)), ([230](#)), ([240](#)), ([250](#)), ([260](#)) are identified for replacement, do appropriate [DISASSEMBLY](#) and [ASSEMBLY](#).
- (4) For each cell ([100](#) or [100A](#)) identified for replacement, do [Cell replacement](#) in [REPAIR](#).
- (5) For each cell ([100](#) or [100A](#)) which have excessive salts around the terminals during visual inspection, do [Lower nut tightness](#).
- (6) For cell hardware ([140](#)), ([150](#) or [150A](#)), ([160](#) or [160A](#)), ([170](#) or [170A](#)), ([180](#)), requiring replacement, do [Cell hardware replacement](#) in [REPAIR](#).
- (7) If terminal O-ring ([190](#) or [190A](#)) requires replacement, do [Terminal O-ring replacement](#) in [REPAIR](#).
- (8) Initial discharge results

NOTE: The results below will be used for a decision point in [Figure 1001](#).

- (a) If the discharge time the first cell reaches 1.0V equals or exceeds the value shown in [Table 1002](#) for the discharged rate, the battery capacity is a "Pass".
- (b) If the discharge time the first cell reaches 1.0V is less than the value shown in [Table 1002](#) for the discharged rate, the battery capacity is a "Fail".



COMPONENT MAINTENANCE MANUAL
4017CH-3

J. Cell shorting

- (1) Using [T01](#), verify the ¼ turn vent valve ([200](#)) is installed on each cell ([100](#) or [100A](#)).
- (2) Discharge each cell in the battery to 0V using one of the two methods below:
NOTE: It is not necessary to have a rest period between a discharge and cell shorting.
 - (a) Method A
 - 1 Continue to discharge the battery per [Table 1002](#) until each cell is < 1.0V, connect a [T03](#) across its terminals. After all the cells have been shorted, leave the devices in place for 12 to 24 hours.
 - (b) Method B
 - 1 Continue to discharge the battery per [Table 1002](#) until each cell is < 0.5V, then connect a shorting clip across its terminals. After all the cells have been shorted, leave these clips on for 16 to 24 hours.
- (3) At completion of Method A or B, remove the shorting devices.
- (4) If no cell(s) are identified for replacement, then return to [Figure 1001](#) utilizing the “Pass” or “Fail” results of the [Initial discharge](#).
- (5) If any cell ([100](#) or [100A](#)) was identified for replacement, do [Cell replacement](#) in [REPAIR](#).

K. Charge

- (1) Allow the battery to cool to ambient temperature.
- (2) Remove the cover ([020](#)) and pad ([030](#)).
- (3) Prior to charging the battery, loosen (do not remove) all ¼ turn vent valves ([200](#)). Ensure that the shorting spring has been removed.
NOTE: If required by [Figure 1001](#), it is recommended to do [Vent valve test](#) during the charge.
- (4) Charge the battery using one of the methods in [Table 1003](#).
 - (a) Record the cell voltages at the start and end of the main charge (Step 1), and the last 30 minutes of the final charge (Step 2).
 - 1 If the start cell voltage of the main charge (Step 1) goes above 1.50V, add to the cell about 10 cm³ (0.61 in³) of [M01](#).
 - 2 During the last during the last 30 minutes of the final charge (Step 2), adjust the [Electrolyte level](#), and check the [Minimum final charge voltage](#).



COMPONENT MAINTENANCE MANUAL
4017CH-3

Main Charge (Step 1)			Final Charge (Step 2)**
Current	Minimum Time*	End of Main Charge Criteria	Current and Time
0.1C ₁ A (4.0A)	9.5h	Every cell >1.5V or 12h*** whichever comes first	0.1C ₁ A (4.0A) for 4h
0.5C ₁ A (20.0A)	1.9h	Every cell >1.55V or 2.5h*** whichever comes first	0.1C ₁ A (4.0A) for 4h
1.0C ₁ A (40.0A)	0.95h	Every cell >1.57V or 1.25h*** whichever comes first	0.1C ₁ A (4.0A) for 4h

* Minimum time applies to a battery previously discharged in 20.0V.

** During the last 30 minutes do [Electrolyte level](#) and confirm minimum voltage criteria in [Table 1004](#).

*** New batteries may take 20% longer than the maximum time provided to reach the proper cell voltages.

Charge Table
Table 1003

(5) Minimum final charge voltage

During the last 30 minutes of final charge (Step 2) measure and verify the voltage of each cell ([100](#) or [100A](#)) meets the value shown in [Table 1004](#). Identify each cell that does not comply.

CELL VOLTAGE (Last 30 minutes at 0.1C ₁ A)
≥ 1.55V

Final Charge Voltage Limit
Table 1004

L. Vent valve test

NOTE: The vent valve test should be done once a year of battery operation or every maintenance interval, whichever is longer. This test is not necessary if all the vent valves ([200](#)) are replaced with new Saft valves each year or maintenance interval, whichever is longer.

NOTE: It is recommended to do this test while the battery is on charge.

CAUTION: THE CELL OPENINGS MUST BE COVERED WITH A CLEAN, DAMP CLOTH TO PREVENT ENTRY OF FOREIGN MATTER.

(1) Check the operation of the vent valve ([200](#)) as follows:

- Using [T01](#), tighten the vent valve ([200](#)) that contains O-ring ([210](#)) onto the test fixture [T05](#).
- Attach the fixture [T05](#) to a compressed air line through an adjustable pressure reducing valve limited to 1.38 bar (20 psi).
- Slowly raise the air pressure to a 1.38 bar (20 psi) maximum to test the functionally below.

COMPONENT MAINTENANCE MANUAL 4017CH-3

- (d) Immerse the valve and end of fixture in water, and slowly raise the pressure. Make sure the valve opens between 0.14 to 0.69 bar (2 psi and 10 psi).
- (e) Reuse only those vent valves found to open in the 0.14 to 0.69 bar (2 psi and 10 psi) range. Re-soak vent valves that do not open at 0.69 bar (10 psi) until they do open (refer to [CLEANING](#) on page [4001](#)). Discard vent valves which are not gas tight at low pressure.

M. Electrolyte level

This procedure is to be carried out during the last 30 minutes of the final charge (Step 2) at 0.1C₁A.

WARNING: USE CARE NOT TO TILT CELLS WHILE VENT VALVES ARE LOOSENED OR REMOVED; CONTACT OF ELECTROLYTE WITH SKIN CAN CAUSE SEVERE BURNS.

CAUTION: USING ANYTHING OTHER THAN [M01](#) IN NICKEL-CADMIUM CELLS WILL CAUSE ELECTROLYTE CONTAMINATION AND DAMAGE. DO NOT RE-USE WATER REMOVED FROM CELLS.

- (1) Remove the ¼ turn vent valves ([200](#)) with [T01](#), taking precautions to prevent foreign substances from entering the cell.
 - (a) Clean the vent valves ([200](#)) by immerse the valves and their O-rings ([210](#)) in [M01](#) and let them soak to dissolve any salts.
- (2) Inserting [T02](#) into the cell opening until the shoulder of the nozzle rests on the valve seat, see [Figure 1003](#).

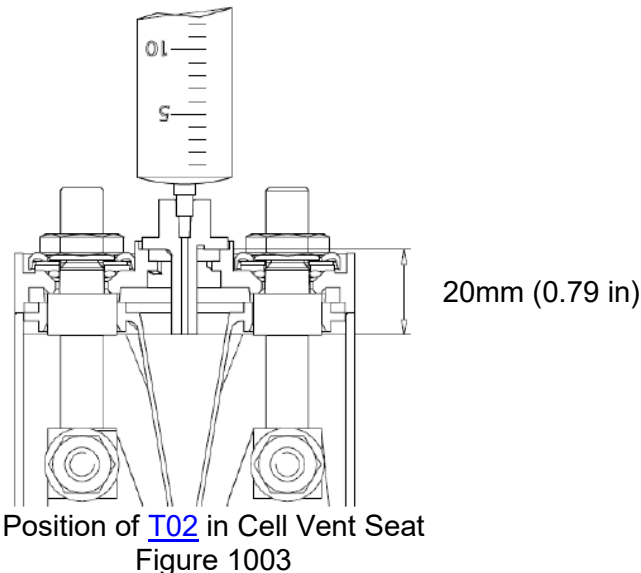

- (3) Withdraw the plunger and check for any liquid in the [T02](#).
 - (a) Any excess liquid in the cell will be drawn into the syringe until the electrolyte level is correct.
 - (b) If the liquid level is too low, the syringe will remain empty, indicating that the end of the syringe nozzle did not reach the liquid in the cell.



COMPONENT MAINTENANCE MANUAL
4017CH-3

NOTE: If the quantity of water added per cell exceeds 70 cm³ (4.27 in³), then check the charging system. If the aircraft charging system is functioning properly, the maintenance period may need be reduced.

- 1 Draw a measured amount of [M01](#), such as 5 cm³ (0.31 in³) into the [T02](#) and inject it into the cell.
- 2 With the syringe nozzle resting on the valve seat, slowly withdraw the plunger into [T02](#).
- 3 If [T02](#) remains empty, repeat steps 1 and 2, counting the total number of cm³ added to achieve the correct level.
- 4 At the point in step 2 when some excess liquid is drawn into [T02](#), the correct level for that cell has been reached. Expel the excess liquid into a separate container for proper disposal of hazardous waste.
- 5 Record the amount of water added/removed from each cell in the battery logbook or battery test sheet.

(4) Using [T01](#), tighten the ¼ turn vent valve ([200](#)) on each cell ([100](#) or [100A](#)).

N. Capacity check (second discharge)

The purpose of this discharge procedure is to verify minimum battery capacity.

- (1) Prior to doing the capacity check, do [Charge](#) and [Electrolyte level](#).
- (2) Using T01, verify the ¼ turn vent valve ([200](#)) is installed on each cell ([100](#) or [100A](#)).
- (3) Discharge the battery at one of the current rates shown in [Table 1005](#) until the battery reaches 20.0V to determine and record the times the first cell reaches 1.0V and battery reaches 20.0V.

NOTE: It is important that the discharge current be continually maintained at the selected value, and that the time of discharge is measured accurately.

NOTE: If a cell goes to zero volts or reverses polarity during the discharge, short out that cell's terminals with a [T03](#) for the remainder of the discharge.

DISCHARGE		MINIMUM TIME FOR FIRST CELL TO 1.0V
RATE (C ₁)	CURRENT (AMPS)	
0.5	20.0	122.0 MINUTES
1.0	40.0	60.0 MINUTES

Capacity Check (Second Discharge)
Table 1005

- (4) If the time the first cell reached 1.0V equals or exceeds the values shown in [Table 1005](#) at the discharge rate, then the capacity is ≥ 100%. Allow the battery to rest at least 2 hours.
- (5) If the time the first cell reached 1.0V is less than the value shown in [Table 1005](#) at the discharge rate, then the capacity is < 100%.



COMPONENT MAINTENANCE MANUAL
4017CH-3

O. Sensor harness test

This test shall be done for a [Battery insulation](#) check failure or disassembly, otherwise the test should be done on a biennial basis by doing [DISASSEMBLY](#) to allow the harness to be removed and tested.

WARNING: A FULLY ASSEMBLED BATTERY MUST BE IN A FULLY DISCHARGED CHARGE STATE TO PREVENT INJURY, REFER TO [CELL SHORTING](#).

- (1) If any part of the sensor harness ([040](#)) is damaged or fails any portion of this test, the entire assembly must be replaced with new Saft sensor harness ([040](#)).

NOTE: A climate chamber or alternate methods may be used, provided the temperatures below are achieved.

NOTE: Refer to [Figure 1002](#) for pinout locations.

- (1) Confirm the battery was discharged and disassembled.
- (2) Verify the sensor values at the temperatures as required by [Table 1006](#). Any erratic readings represent a failure and replace with new Saft sensor harness ([040](#)).

ITEM	PINS	VALUES
T1	Pin 1 – 2	Closes < 5Ω on rise @+57 ± 2.8°C (+135 ± 5°F) Opens > 20MΩ maximum differential of @ -6.2°C (-12°F) Max
T2	Pin 3 – 4	Closed < 5Ω @ +1.8 ± 2.8°C (+35 ± 5°F) Opens > 20MΩ @ +10°C (+50°F) Max

Sensor Harness Test Values
Table 1006

P. Special testing

These procedures are to be followed for a battery that does not meet capacity or if the end of charge cell voltage < 1.55V during the final charge. Refer to [Figure 1004](#) flow chart.

NOTE: For a new battery or one removed from the aircraft that has not passed capacity after doing the Special Testing more than 3 times, it is recommended to replace noncompliant cells with new Saft cells ([100](#) or [100A](#)), refer to [All cell replacement](#) recommendation in [REPAIR](#).

NOTE: For battery from long-term storage, several complete charge/discharge cycles may be needed to restore performance.

- (1) Special testing decision
For a battery with < 100% capacity, do [Low capacity \(Special testing\)](#). Otherwise for a battery with any cell voltage < 1.55V, do [Supplementary test](#).
- (2) Low capacity (Special testing)
 - (a) Loosen, but do not remove all ¼ turn vent valves ([200](#)) and fully charge the battery as outlined in [Charge](#) section.
 - (b) For a battery containing any cell with voltage < 1.55V during the final charge, do [Supplementary test](#). Otherwise, do [Capacity test \(Special testing\)](#).



COMPONENT MAINTENANCE MANUAL
4017CH-3

- (3) Supplementary test
- (a) Charge at $0.1C_1A$ for an additional 5 hours and monitor the voltage of the individual cells every 30 minutes.
- NOTE:** The additional $0.1C_1A$ 5-hour charge may be stopped once all the cells are $\geq 1.55V$.
- 1 Identify for replacement any cell ([100](#) or [100A](#)) with voltage $< 1.55V$.
 - 2 During the last 30 minutes of this charge, adjust the [Electrolyte level](#).
 - 3 Do [Cell replacement](#) in [REPAIR](#) for cells identified for replacement. Otherwise, do [Capacity test \(Special testing\)](#).
- (4) Capacity test (Special testing)
- (a) Using T01, verify the $\frac{1}{4}$ turn vent valve ([200](#)) is installed on each cell ([100](#) or [100A](#)).
- (b) Discharge the battery at a rate shown in [Table 1005](#) until the battery reaches 20.0V. Record the time and current the battery reached 20.0V and identify noncompliant cells with voltage $< 1.0V$.
- (c) If the time the first cell reached 1.0V equals or exceeds the values shown in [Table 1005](#) at the applicable discharge rate, then return to [Figure 1001](#). Otherwise repeat this procedure [Low capacity \(Special testing\)](#) or refer to [Fault Isolation](#).
- 1 For noncompliant cells that failed this capacity test 3 times, replace with new Saft cells ([100](#) or [100A](#)), refer to [Cell replacement](#) in [REPAIR](#).

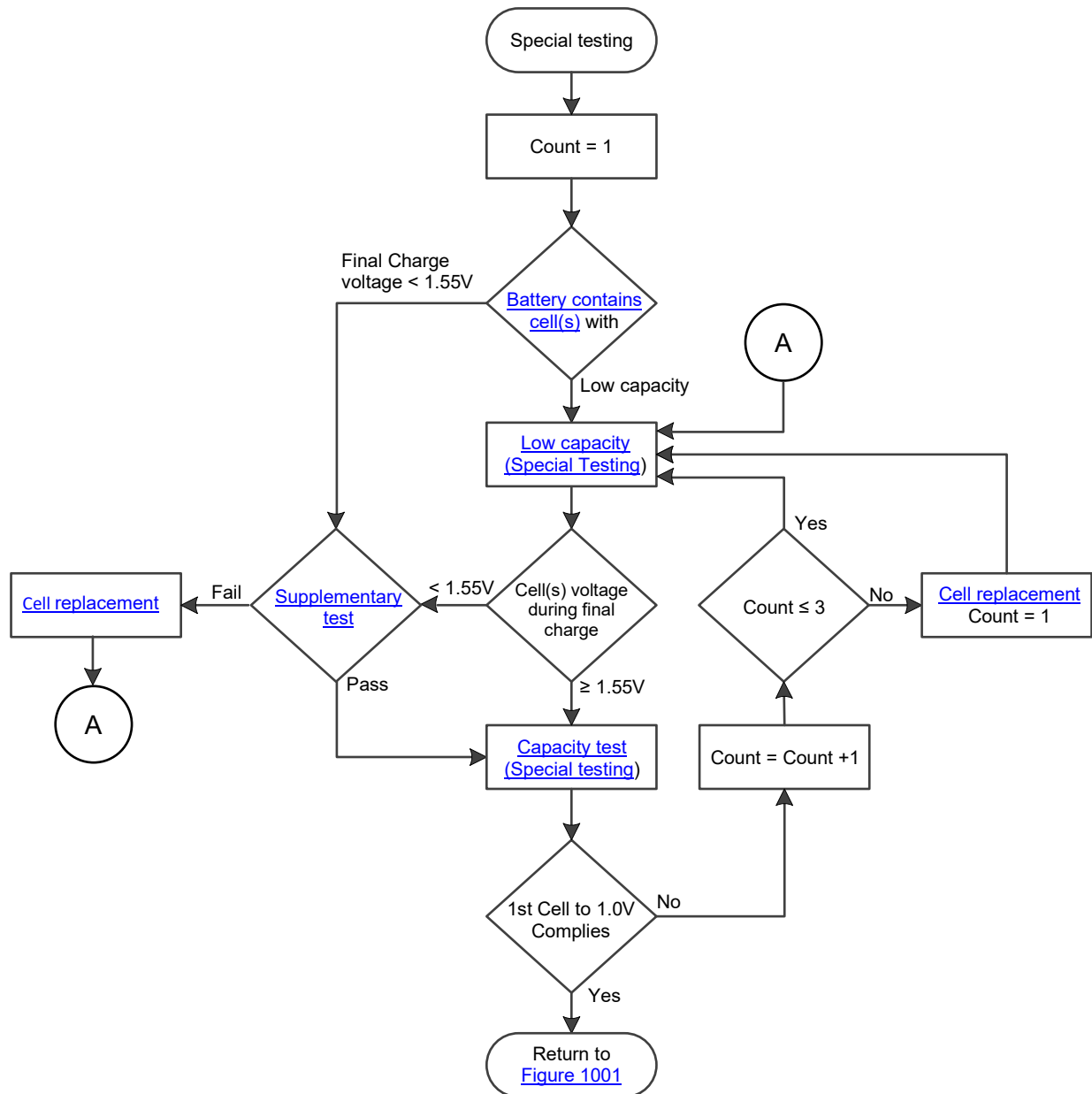

Special Testing Flow Chart
Figure 1004

Q. Lower nut tightness

- (1) Remove applicable hardware; nuts (080), (110), washers (090), (120 or 120A) and links (220 to 260). Torque the lower nut (140) per Table 8001.
- (2) Install the applicable hardware; the links (220 to 260), washers (090), (120 or 120A), and nuts (080), (110). Torque the nuts per Table 8001.



COMPONENT MAINTENANCE MANUAL
4017CH-3

5. Fault Isolation

Fault isolation information is presented in [Table 1007](#), [Table 1008](#), or [Table 1009](#) as a guide to locate the cause of malfunction and isolating the cause to a specific component.

TROUBLE	PROBABLE CAUSE	REMEDY
(1) No battery voltage	(a) Defective electrical connector (not making contact). (b) Broken or loose terminal links	Check electrical connections Replace if required using DISASSEMBLY and ASSEMBLY
(2) Low Insulation	(a) Leakage of electrolyte (b) Incorrect electrolyte level (c) Reverse cell polarity (d) Condensation / Contamination (e) Improper cleaning (f) Loose or damage vent valve (g) Damaged cell case (h) Charge rate too high	Do Thorough Cleaning , ASSEMBLY , Charge , Electrolyte level Tighten or replace ¼ turn vent valve, do Thorough Cleaning , ASSEMBLY , Charge , Electrolyte level Do Thorough Cleaning , Cell replacement , ASSEMBLY , Charge , Electrolyte level Investigate the cause of the excessive charge. Do Thorough Cleaning , ASSEMBLY , Charge , Electrolyte level
(3) Loss of battery capacity	(a) Normal wear after long service (b) Exceptionally heavy use	Do Special testing

Battery Faults
Table 1007



COMPONENT MAINTENANCE MANUAL
4017CH-3

TROUBLE	PROBABLE CAUSE	REMEDY
(1) Cell water consumption is above the maximum allowed	(a) Charged more than allowed or charged at high temperature. (b) Previous maintenance has not been done (c) Maintenance interval too long	Examine the cause of the excessive charge. Do Charge , and Electrolyte level be sure what for the next maintenance interval. If this continues the maintenance interval should be done reduced.
(2) High water consumption in one or more cells	(a) Damaged separator when the water consumption is less than 30% below the average value of added water in all cells. (b) Cell imbalance when water addition is more than 30% above the average value of added water in all cells.	Do Charge , Supplementary test . Do Thorough Cleaning , Cell replacement , ASSEMBLY , Charge , Electrolyte level
(3) Abnormally high cell voltage at beginning of charge	(a) Dry cell	Add 5 to 10 cm ³ (0.31 to 0.61 in ³ of distilled water, do Electrolyte level
(4) Zero Voltage on cell	(a) Short-circuited cell	Do Cell replacement
(5) Low cell voltage at end of charge	(a) Separator damage	Do Cell replacement
(6) Low cell capacity	(a) Normal wear from long service	Do Cell replacement
(7) Cell with a swollen case	(a) Cell operated with low electrolyte level, deterioration of separator and damaged plates	Do Cell replacement

Cell Faults
Table 1008



COMPONENT MAINTENANCE MANUAL
4017CH-3

TROUBLE	PROBABLE CAUSE	REMEDY
(1) Tarnished or burned terminal connectors	(a) Loose terminal nuts and links	Clean and torque per Table 8001 .
(2) Exposed copper material on power connector pin	(a) Mechanical damage (b) Electrical arcing	Replace component using DISASSEMBLY and ASSEMBLY
(3) Melted plastic on connectors	(a) Overheat due to contact resistance	Replace component using DISASSEMBLY and ASSEMBLY
(4) Corroded links	(a) Operation in acidic atmosphere (b) Inadequate greasing (c) Mechanical damage to protective nickel-plating	Check room eliminate acid source, replace component using DISASSEMBLY and ASSEMBLY Replace component using DISASSEMBLY and ASSEMBLY Replace component using DISASSEMBLY and ASSEMBLY
(5) Battery case and cover damage with dents, deformations, and visible cracks which affect fit or impede performance.	(a) Various, transport (b) Mechanical stress, drop	Replace component using DISASSEMBLY and ASSEMBLY

Physical Faults
Table 1009



COMPONENT MAINTENANCE MANUAL
4017CH-3

DISASSEMBLY

1. General

This section provides step-by-step instructions on disassembling the complete battery.

NOTE: The () part identification numbers herein are [IPL Figure 1](#) item numbers.

2. Detailed Instructions

WARNING: BATTERY CELLS DELIVER VERY HIGH CURRENTS WHEN SHORT-CIRCUITED. EXERCISE CAUTION. REMOVE RINGS, WATCHES OR OTHER JEWELRY FROM HANDS AND ARMS.

WARNING: BATTERY MUST BE COMPLETELY DISCHARGED BEFORE CELL ASSEMBLIES CAN BE REMOVED DUE TO POSSIBILITY OF ELECTRIC SHOCK.

WARNING: USE CARE NOT TO TILT BATTERY WHILE ¼ TURN VENT VALVES ARE LOOSENEED; CONTACT OF ELECTROLYTE WITH SKIN CAN CAUSE SEVERE BURNS.

A. Preparation

- (1) Discharge the battery at one of the current rates shown in [Table 1005](#) until each cell reaches 1.0V.
- (2) Remove cover ([020](#)) and pad ([030](#)) by opening latches and lifting cover from case ([010](#)).
- (3) Do [Cell shorting](#)

B. Cell ([100](#) or [100A](#)) Removal

- (1) Remove the upper nuts ([080](#)), ([110](#)) and washers ([090](#)), ([120](#) or [120A](#)) from the battery.
- (2) Remove intercell terminal links ([220](#) through [260](#)) from terminals of cells ([100](#) or [100A](#)).
- (3) Using [T04](#), tighten on the cell terminals as needed to remove cells ([100](#) or [100A](#)) from the battery case ([010](#)).

C. Disassembly of the cells ([100](#) or [100A](#)) is restricted to replacing defective cell hardware ([140](#)), ([150](#) or [150A](#)), ([160](#) or [160A](#)), ([170](#) or [170A](#)), ([180](#)) or terminal O-rings ([190](#) or [190A](#)), refer to [Component replacement](#) in [REPAIR](#).

D. Power connector ([280](#)) removal

- (1) Remove screws ([290](#)) from the connector.
- (2) Remove power connector ([280](#)) and its gasket ([300](#)) from the battery case ([010](#)).



COMPONENT MAINTENANCE MANUAL
4017CH-3

- E. Sensor harness ([040](#)) removal
 - (1) Remove the connector nut ([070](#)) and O-ring ([050](#)) of the sensor assembly from the battery case ([010](#)).
 - (2) Separate the thermostats from links ([250](#)), ([260](#)) by removing the hex nuts ([060](#)).
- F. Remove all spacers ([310](#)) from the battery case ([010](#)).



COMPONENT MAINTENANCE MANUAL
4017CH-3

CLEANING

1. General

CAUTION: DO NOT USE PETROLEUM SPIRITS, TRICHLOROETHYLENE OR OTHER SOLVENTS FOR CLEANING THE BATTERY. USE OF THESE PRODUCTS MAY DETERIORATE THE INTEGRITY OF METAL PARTS.

NOTE: The () part identification numbers herein are [IPL Figure 1](#) item numbers.

- A. The following items are required for cleaning procedures (equivalent substitutes can be used):
- Stiff bristled brush (nonmetallic)
 - Dry compressed air source, less than 1.38 bar (20 psi)
 - Safety goggles
 - Lubricant, non-acid petroleum jelly, [M02](#)
 - Soft, clean cloth (two required)
 - Running water
 - Mild soap, [M03](#)
 - Distilled or de-ionized water, [M01](#)

2. Light Cleaning

- A. The following procedures are for an assembled battery with battery cover ([020](#)) and pad ([030](#)) removed.
- B. Using [T01](#), make sure the ¼ turn vent valve ([200](#)) of each cell ([100](#) or [100A](#)) is closed and secure. Do not over-tighten.
- CAUTION:** DO NOT USE A WIRE BRUSH TO CLEAN CELL TOPS. CELLS MAY BE DAMAGED.
- C. Remove white deposits (potassium carbonate) from tops of all cell assemblies ([100](#) or [100A](#)) using a stiff bristled nonmetallic brush.
- WARNING:** TO PREVENT INJURY WHEN USING COMPRESSED AIR, DIRECT STREAM AWAY FROM BODY. USE SAFETY GOGGLES TO PREVENT EYE INJURIES FROM FINE DUST PARTICLES.
- D. Disperse residual dust and particles from the battery with blasts of clean, dry, compressed air not over 1.38 bar (20 psi).
- E. Coat hex nuts ([080](#)), ([110](#)), ([140](#)), washers ([090](#)), ([120](#) or [120A](#)) ([170](#) or [170A](#)), ([180](#)), and all intercell terminal links ([220](#) through [260](#)) with [M02](#).
- CAUTION:** SILICONE COATINGS ARE NOT SUITABLE DUE TO THE ALKALINE ELECTROLYTE.
- F. Clean the exterior surfaces of the battery cover ([020](#)) and battery case ([010](#)) using a soft, clean cloth, moistened with water. Dry with compressed air or a dry, clean cloth.



COMPONENT MAINTENANCE MANUAL
4017CH-3

3. Thorough Cleaning

- A. The battery must be discharged (refer to [Initial discharge](#) and [Cell shorting](#)) and disassembled (refer [DISASSEMBLY](#)).
- B. Remove greasy residue from power connector ([280](#)) with warm mild soapy [M03](#) water.
- C. After ensuring that the ¼ turn vent valves ([200](#)) are closed, wash each cell ([100](#) or [100A](#)) in running water. Do not allow any water to enter the cell. Dry with compressed air or a dry, clean cloth.
- D. Without submerging the connector of sensor harness ([040](#)), wipe clean with damp cloth and let dry.
- E. Wash the battery case ([010](#)), cover ([020](#)), spacers ([310](#)), gasket ([300](#)), O-ring ([050](#)), nuts ([060](#)), ([070](#)), ([080](#)), ([110](#)), washers ([090](#)), ([120](#) or [120A](#)), intercell links ([220](#) through [260](#)), and screws ([290](#)) in warm mild soapy [M03](#) water to remove dirt and salt deposits. A plastic scraper or a stiff bristled brush (nonmetallic) may be used to aid in the removal of heavy deposits. Rinse away [M03](#), and thoroughly dry with compressed air or a dry, clean cloth.



COMPONENT MAINTENANCE MANUAL
4017CH-3

CHECK

1. General

This section contains battery inspection information. The procedures are written in step-by-step formats that follow the process flow outlined in [Figure 1001](#).

NOTE: All voltage readings are DC unless otherwise stated.

NOTE: All () part identification numbers herein are [IPL Figure 1](#) item numbers.

2. Initial New Battery Commissioning

A. Before the initial charge, thoroughly inspect the battery assembly to ensure no damage has occurred during shipping or storage as follows:

NOTE: For a new battery not receiving its initial commission within one year of its DOM, then battery must follow [Figure 1001](#)

- (1) Inspect the battery case ([010](#)) and cover ([020](#)) for dents, distortion, or other damage. If found, replace with new Saft cover ([020](#)) or case ([010](#)).
- (2) Remove the battery cover ([020](#)) and pad ([030](#)).
- (3) Visually confirm the power connector ([280](#)) is present and undamaged.
- (4) Visually confirm all cells ([100](#) or [100A](#)) are positioned for proper polarity per [Figure 7002](#).
- (5) Visually confirm all cells ([100](#) or [100A](#)) are equipped with a ¼ turn vent valve ([200](#)).
- (6) Tighten all upper nuts ([080](#)), ([110](#)) per [Table 8001](#).
- (7) Visually confirm the sensor harness ([040](#)) is present and undamaged.

B. Charge the battery per [Charge](#) on page [1007](#) and level electrolyte per [Electrolyte leveling](#) on page [1009](#).

C. Do successful [Battery insulation](#) test then install battery cover ([020](#)) and pad ([030](#)), then the battery is ready for service.

3. Component Inspection

A. Cell ([100](#) or [100A](#))

- (1) Visually check for evidence of electrolyte leakage, cracks, corrosion, burns, holes, or cross-threaded terminals. Replace any defect cells with new Saft cells ([100](#) or [100A](#)).
- (2) Excessive salt around a terminal post indicates leakage. Refer to [Terminal O-ring replacement](#) on page [6002](#) for replacement of lower terminal O-ring ([190](#) or [190A](#)) if leakage is evident.
- (3) Visually check each cell ¼ turn vent valve ([200](#)) for defective O-rings ([210](#)), cracks, or other physical damage. Replace defective O-rings ([210](#)).
 - (a) Suspect vent valves should be tested in accordance with [Vent valve tests](#) on page [1008](#) and/or be discarded, if necessary.



COMPONENT MAINTENANCE MANUAL
4017CH-3

- B. Inspect the (080), (110) and washers (090), (120 or 120A) to ensure it is free of bends, tarnish, corrosion, burns, or loss of plating. Minor tarnish can be polished off with a fine wire brush. Defective hardware should be replaced.
- C. Intercell terminal links (220 through 260)
Inspect for bends, tarnish, loss of nickel plating, corrosion, or burns. Tarnish can be polished off with a fine wire brush. Replace any defective intercell links.
- D. Spacers (040)
Inspect for contamination and free of cracks or holes. Replace any that are defective.
- E. Power connector (280)

CAUTION: A DEFECTIVE POWER CONNECTOR CAN CAUSE DANGEROUS OVERHEATING AND IN-SERVICE LOW VOLTAGE DURING DISCHARGE.

- (1) Check the power connector (280) for evidence of arcing, corrosion, cracks, or cross threaded terminals.
 - (2) Using the same methods in [Battery insulation](#) check on page 1004, check the insulation between the positive pin and the connector shell and the negative pin and connector shell.
 - (3) Discard any connector that is found to have any damage or fails the insulation test and replace with new Saft battery power connector (280).
- F. Sensor harness (040)
- (1) Inspect electrical connector for bent or loose pins, corrosion, cracks, faulty wire connections, and evidence of arcing.
 - (2) Visually check all wiring damage to insulation, cracked or broken wire, and other physical defects
 - (3) Inspect thermostats for damage, loose or broken wire connections, cracks, dents, or other physical defects.
 - (4) Any evidence of the above conditions, however minor, is grounds for rejection. Discard the damaged unit and replace with factory new.

NOTE: Sensor harness (040) is a non-repairable item and should be replaced if defective.

- G. Battery cover (020), case (010), and pad (030)
Inspect the components for damage. If found, replace with new Saft cover (020), case (010), or pad (030).



COMPONENT MAINTENANCE MANUAL
4017CH-3

REPAIR

1. General

This section contains basic battery component procedures for removing and replacing components.

NOTE: The () part identification numbers herein are [IPL Figure 1](#) item numbers.

NOTE: All voltage readings are DC unless otherwise stated.

2. Required Test Equipment

NOTE: Test equipment with equivalent specifications can be used.

Refer to [Special Tools, Fixtures, Equipment, and Consumables](#) for listing of Standard Tools.

3. Component Replacement

A. Cell replacement ([100](#) or [100A](#))

A battery containing cell(s) ([100](#) or [100A](#)) require replacement. Note the [All cell replacement](#) recommendation below.

(1) All cell replacement

(a) For a battery compliant with the following, it is best to assume that all the original cells are or soon will be in unsatisfactory condition. Saft strongly recommends all cells ([100](#) or [100A](#)) should be replaced with new Saft cells for a battery having:

1 3 or more faulty cells are replaced during the same maintenance interval.

Or

2 1 or more cells are found to be faulty during this maintenance period and 5 of the original cells in the battery have been previously replaced due to faults.

NOTE: The recommendation does not apply to the following failures: terminal thread damage, cell leakage, or cell short-circuit

(2) Do [DISASSEMBLY](#) and [ASSEMBLY](#) to replace cells.

B. Cell hardware replacement

WARNING: USE CARE NOT TO TILT CELLS WHILE LOWER HARDWARE ARE LOOSENED OR REMOVED; CONTACT OF ELECTROLYTE WITH CAN CAUSE SEVERE BURNS.

NOTE: The battery should be discharged prior to starting cell hardware replacement.

(1) Replace necessary cell hardware ([140](#)), ([150](#) or [150A](#)), ([160](#) or [160A](#)), ([170](#) or [170A](#)), ([180](#)) by removing and replacing the nuts ([080](#)), ([110](#)), washers ([090](#)), ([120](#) or [120A](#)), and links ([220](#) to [260](#)). Torque nuts per [Table 8001](#).



COMPONENT MAINTENANCE MANUAL
4017CH-3

C. Terminal O-ring replacement

- (1) Remove necessary hardware; nuts ([080](#)), ([110](#)), washers ([090](#)), ([120](#) or [120A](#)), and links ([220](#) to [260](#)).

WARNING: USE CARE NOT TO TILT CELLS WHILE LOWER HARDWARE ARE LOOSENED OR REMOVED; CONTACT OF ELECTROLYTE WITH CAN CAUSE SEVERE BURNS.

- (2) Remove lower nut ([140](#)), the polarity washer ([150](#) or [150A](#)) or ([160](#) or [160A](#)), the washers ([170](#) or [170A](#)), ([180](#)), and terminal O-ring ([190](#) or [190A](#)) being careful to prevent anything from falling into the cell opening.
- (3) Replace O-ring ([190](#) or [190A](#)), install washers ([180](#)), ([170](#) or [170A](#)), the polarity washer ([150](#) or [150A](#)) or ([160](#) or [160A](#)), and torque lower hex nut ([140](#)) per [Table 8001](#).

NOTE: Spring washers ([170](#)) should be put in parallel, stacked in the same direction with the larger edge downward on the terminal.

- (a) Install the necessary links ([220](#) to [260](#)), washers ([090](#)), ([120](#) or [120A](#)), and nuts ([080](#)), ([110](#)). Torque nuts per [Table 8001](#) as required.



COMPONENT MAINTENANCE MANUAL
4017CH-3

ASSEMBLY

1. General

This section contains assembly instructions necessary after disassembly.

NOTE: Make sure all components are clean and dry before re-assembly.

NOTE: All () part identification numbers herein are [IPL Figure 1](#) item numbers.

2. Sensor harness (040)

A. Install the O-ring ([050](#)) onto harness connector before placing the connector through the hole in the battery case ([010](#)). Install nut ([070](#)) and torque per [Table 8001](#).

B. For sensor harness ([040](#)), secure and torque the thermostat studs in place on links ([250](#)) and ([260](#)) with nuts ([060](#)), refer to [Table 8001](#)

3. Power connector (280)

Place the gasket ([300](#)) onto the power connector ([280](#)) and insert terminals through the oval mounting hole in the front of the battery case ([010](#)) and installing screws ([290](#)). Secure the receptacle by torquing the screws ([290](#)) per [Table 8001](#).

4. Spacers (310) and cells (100 or 100A)

Install spacers ([310](#)) and cell assemblies ([100](#) or [100A](#)) into the battery case ([010](#)), using the following steps. Refer to [Figure 7001](#) or [Figure 7002](#).

A. Insert one edge of bottom spacer into battery case ([010](#)) from the left or right side, then slide the spacer under the cell partition.

NOTE: Cell insertion is typically easier when a middle cell is the last installed in each row.

B. Install the left and right side row of cells ([100](#) or [100A](#)) and spacers ([310](#)) in accordance to [Figure 7001](#) and [Figure 7002](#). Be sure to maintain the proper cell arrangement and polarity orientation as shown in [Figure 7002](#). Insertion of the last cell on each side is sometimes difficult and can be assisted by pushing down on the terminals with a small block of soft wood.

NOTE: Spacers are used as required to ensure the cells are retained securely in place. As indicated in [Figure 7001](#), the maximum quantity to be used is as shown.

C. Install the center row of cells ([100](#) or [100A](#)) and spacers ([310](#)) in accordance to [Figure 7001](#) and [Figure 7002](#). Be sure to maintain the proper cell arrangement and polarity orientation as shown in [Figure 7002](#). Insertion of the last cell is sometimes difficult and can be assisted by pushing down on the terminals with a small block of soft wood.

D. Torque the lower hex nuts ([140](#)) of the cell assemblies ([100](#) or [100A](#)) per [Table 8001](#).

E. Apply a small amount of [M02](#) to the threads of the cell terminals.

24-32-03

7001

Oct 5/2022

COMPONENT MAINTENANCE MANUAL 4017CH-3

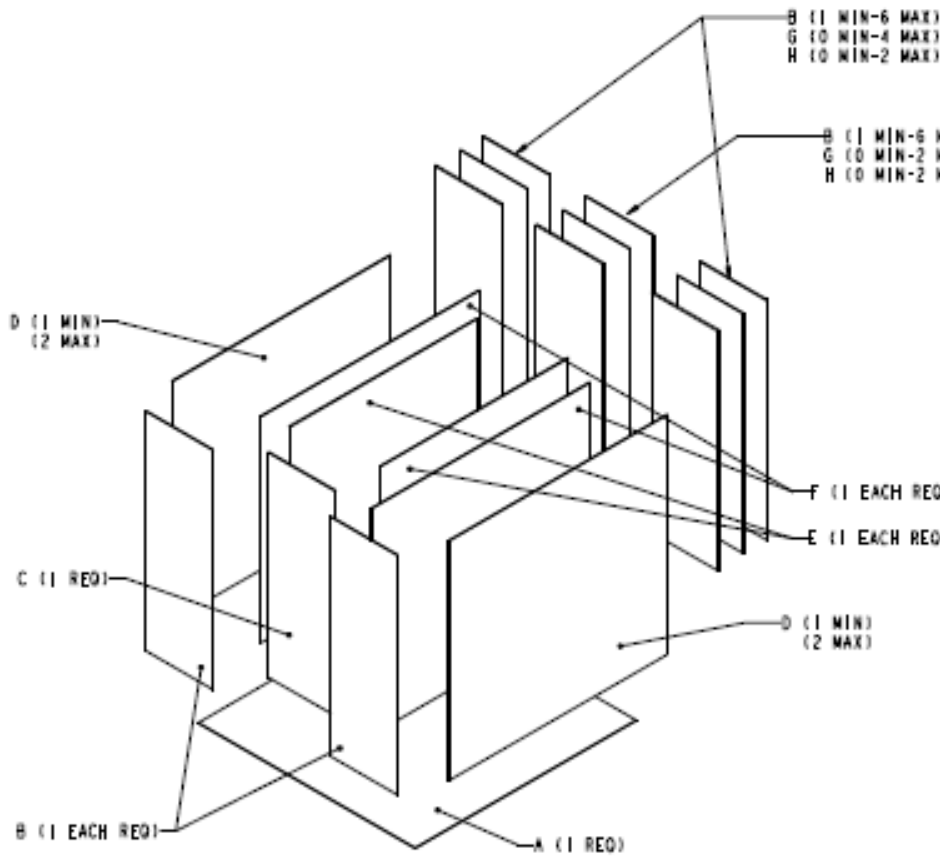

Item	Description	Dimension (in)	Unit Per Assembly
A	Spacer	9.580 x 9.780 x 0.015	1
B	Spacer	2.953 x 9.173 x 0.020	20
C	Spacer	2.953 x 8.610 x 0.032	1
D	Spacer	9.646 x 9.173 x 0.032	4
E	Spacer	8.268 x 8.661 x 0.032	2
F	Spacer	9.646 x 8.661 x 0.020	2
G	Spacer	2.953 x 9.173 x 0.032	10
H	Spacer	2.953 x 9.173 x 0.062	6

Spacer Kit (310) Installation
Figure 7001

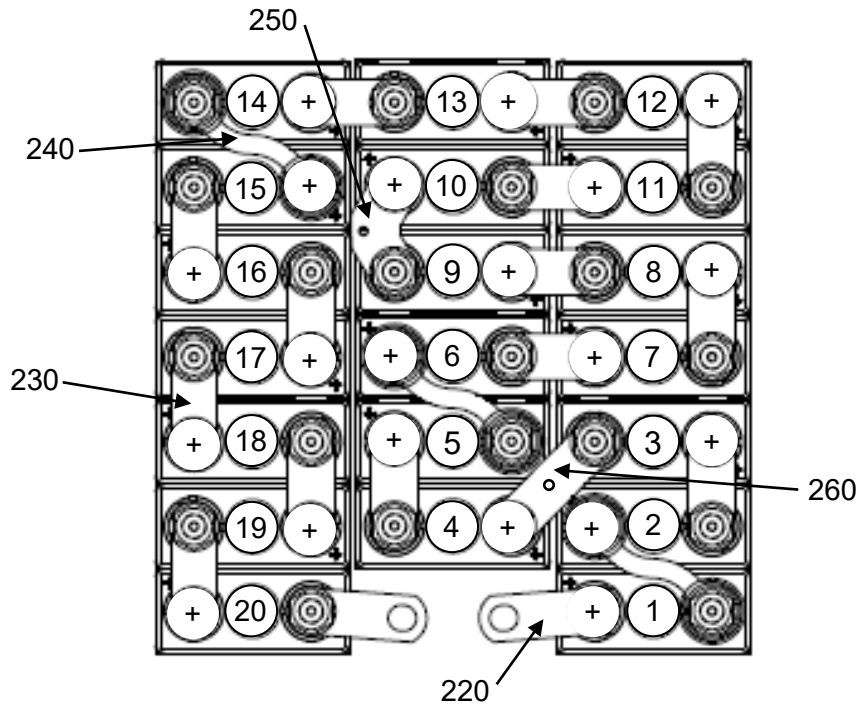

Cell Number and Polarity Orientation
Figure 7002

5. Power connector (280)

Install power connector (280) into the battery case (010) follows:

- A. Assemble power connector gasket (300) to power connector (280).
- B. Insert terminals of power connector (280) through the oval mounting hole in the front of the battery case (010).
- C. Attach the power connector (280) to the battery case (010) with screws (290). Secure the power connector (280) by torquing the screws (290) per [Table 8001](#).

6. Complete Battery

- A. Install intercell terminal links (220 through 260) on the terminals of the cell sub-assemblies (100 or 100A) and power connector (280) as shown in [Figure 7002](#) and [Figure 7003](#).

COMPONENT MAINTENANCE MANUAL 4017CH-3

- B. Install the two wire lead/thermostat assemblies of the sensor harness (040) on the top of the cell sub-assemblies (100 or 100A) as shown in Figure 7003.

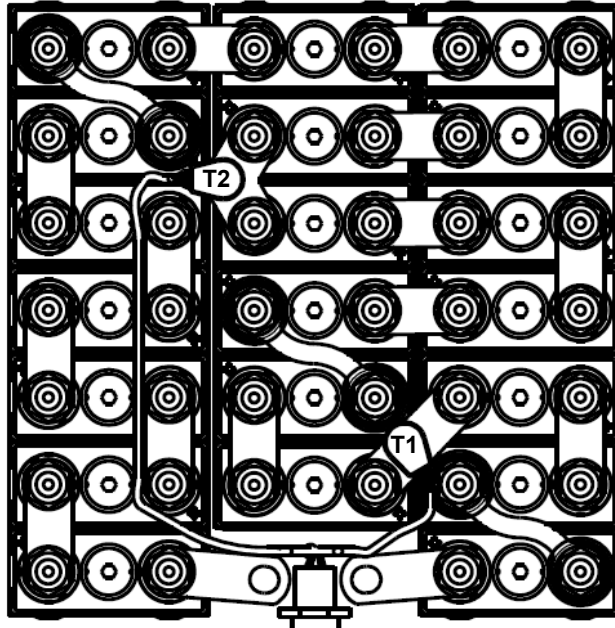

Sensor Harness Routing
Figure 7003

- A. Lightly lube with M02 the cell terminals, nuts, links, and power connector contacts using a nonmetallic brush.
- B. Install the washers (090), (120 or 120A) and upper hex nuts (080), (110) onto the terminals of the cell assemblies (100 or 100A) and power connector adapter (280). Torque nuts per Table 8001.
- C. Lightly lube with M02 any other components that might be susceptible to atmospheric corrosion

CAUTION: DO NOT CRIMP OR PINCH WIRES OF THE SENSOR HARNESS.

- D. Install the pad (030) onto the cell assemblies, being sure that each vent hole mates properly with the cell assembly vent valve.
- E. Install the battery cover (020) onto the battery case (010) and secure in place by fastening the latches.



COMPONENT MAINTENANCE MANUAL
4017CH-3

FITS AND CLEARANCES

1. Torque Table

IPL FIGURE	ITEM NUMBER	TORQUE VALUE		NAME, LOCATION
		Nm	lb _f -in	
1	080, 110	13.0 ± 1.0	115 ± 9	Nut, Terminal, Upper
1	140	5.0 ± 0.5	44 ± 4	Nut, Terminal, Lower
1	060	1.1 ± 0.1	10 ± 1	Lock Nut, Thermostat
1	290	2.3 ± 0.2	20 ± 2	Sems Screw, Power Connector
1	070	5.6 ± 0.6	50 ± 5	Nut, Harness Connector

Torque Values
Table 8001

2. Fits and Clearances Table

No fits and clearances required.



COMPONENT MAINTENANCE MANUAL
4017CH-3

PAGE INTENTIONALLY LEFT BLANK

24-32-10

8002
Mar 1/2022



COMPONENT MAINTENANCE MANUAL
4017CH-3

SPECIAL TOOLS, FIXTURES, EQUIPMENT, AND CONSUMABLES

1. Special Tools

A. Battery maintenance kit

NOTE: Equivalent tools can be used.

NOTE: A special tool kit (P/N 416161) is available from Saft containing special tools T01, T02, T03, and T04. The tools are housed in a polypropylene box.

- (1) T02 (P/N 416232) is assembled using syringe P/N 105112 and nozzle P/N 104184. T02 (P/N 020916-001) is assembled using syringe P/N 018327-000 and nozzle P/N 020914-001.

ITEM	DESCRIPTION	09052 P/N	F6177 P/N
T01	Universal vent wrench	093365-000	413876
T02	Syringe assembly (with nozzle 20 mm (0.79 in))	020916-001	416232
T03	1.2Ω 3W equalizing resistors	-	164829
T04	Universal cell extraction tool	-	416159
	M10x1.25 tool	017556-000	-
T05	Vent Valve adapter for MS valves	024398-000	-

Special Tools
Table 9001

2. Standard Tools

A. The following items are recommended to do the procedures described in this manual. When necessary equivalent substitutes may be used.

- Constant current charger (DC current range 0 – 60A, minimum open DC voltage 40V)
- Constant current load bank (DC current range 0 – 60 A, DC voltage range 1 – 40V)
- Megohmmeter (0 – 50 MΩ @ 250 V DC continuous)
- Precision Multimeter (Volt, Ω, mA) 2000 count, accuracy 1% or better
- Torque Wrench (Insulated) 0 to 15 N-m (0 to 133 lb_f-in)
- Torque Screwdriver 0 to 3.4 N-m (0 to 30 lb_f-in)
- Thermometer, Immersion
- Standard mechanic's tools.
- Safety gloves.
- Protective goggles.
- Safety shoes.
- Eye wash.
- Protective apron.
- Stiff bristle brush (non-metallic)
- Small paintbrush (non-metallic)
- Dry, compressed air source [less than 1.38 bar (20 psi)]
- Soft, clean cloth (at least two required)

24-32-10

9001
Oct 5/2022



COMPONENT MAINTENANCE MANUAL
4017CH-3

3. Consumables

This paragraph describes the consumables used in the CMM.

NOTE: Equivalent alternatives can be used for list items.

ITEM	DESIGNATION PART NUMBER AND SPECIFICATION DESCRIPTION	MANUFACTURER OR SUPPLIER (NAME, ADDRESS, CODE)
M01	<p>Distilled or deionized water @ +20°C ± 5°C (+68°F ± 9°F):</p> <p>Clear, colorless, and odorless while boiling</p> <p>Conductivity < 33 µS/cm</p> <p>5 < pH < 7</p> <p>Mn-COD < 30 mg/l (1.7 x 10⁻⁵ oz/in³) (Chemical Oxygen Demand, methodology to evaluate organic or mineral pollution)</p> <p>Chlorines Cl⁻ < 5 mg/l (2.9 x 10⁻⁶ oz/in³)</p> <p>Sulfates SO₄²⁻ < 10 mg/l (5.8 x 10⁻⁶ oz/in³)</p> <p>STORAGE: dry and clean container without any corrosion and damage; Temperature: +20°C ± 5°C (+68°F ± 9°F). Over 1 year of storage, do an analysis of the liquid.</p>	Local Vendor
M02	<p>Neutral petroleum jelly</p> <p>Density @ +60°C (+140°F) Range = 0.840 to 0.866 kg/l (0.486 to 0.501 oz/in³)</p> <p>Melting Point Range = +46°C to +52°C (+115°F to +126°F)</p> <p>Acidity/Alkalinity = Neutral to Litmus</p>	<p>Mineral Vaseline</p> <p>NATO: S 743</p> <p>F: AIR 3565</p> <p>US: VV-P-236A</p> <p>UK: DEF 2333</p>
M03	Mild soap	Local Vendor

Consumables
Table 9002

24-32-10

9002
Mar 1/2022



COMPONENT MAINTENANCE MANUAL
4017CH-3

ILLUSTRATED PARTS LIST

1. Introduction

A. Purpose

- (1) This section provides illustrations and parts breakdown of the 4017CH-3 batteries, which can be disassembled, replaced, and reassembled.

B. Explanation and usage of section

- (1) Assembly order indenture system

The Indenture System used in the parts list shows the relationship of one part to another. For a given item, the number of indentures depicts the relationship of the item to the associated next higher assembly.

- (2) Effectively code

Reference letters (A, B, C, etc.) are assigned in the EFF CODE column to each top assembly. The reference letter of the applicable top assembly is also shown in the EFF CODE column for each detail part and subassembly except that no reference letter is shown for detail parts and subassemblies used on all top assemblies.

- (3) Quantity per assembly

The UNITS PER ASSY column shows the total number of units required per assembly, per subassembly, and per sub-subassembly as applicable. The letters REF indicates the item is listed for reference purposes.

- (4) Parts replacement data

Interchangeability information will be provided in a future manual revision if it becomes applicable.

- (5) Service Bulletin incorporation

Service Bulletin incorporation information applicable to the parts list will be provided in a future manual revision if it becomes applicable.

- (6) Items not illustrated

Items not illustrated are indicated by a dash (-) ahead of the item numbers in the Figure and Index column.

- (7) Alpha variant item numbers

- (a) Alpha variants A - Z (except I and O) are assigned to existing item numbers when necessary to show:

- 1 Added items
- 2 Service Bulletin modifications
- 3 Configuration differences
- 4 Optional parts
- 5 Product improvement parts (non-service bulletin)

24-32-10

10001
Mar 1/2022



COMPONENT MAINTENANCE MANUAL
4017CH-3

(b) Alpha variant item numbers are not shown on the exploded view when the appearance and location of the alpha variant item is the same as the basic item.

(8) Vendors

The vendor of all parts shown in the parts list is as follows:

CAGE Code	NAME / ADDRESS	CAGE Code	NAME / ADDRESS
09052	Saft America Inc. 711 Gil Harbin Industrial Boulevard Valdosta, GA 31601 USA Phone: +1 (229) 247-2331 Fax: +1 (229) 247-8486	F6177	Saft 126 quai Charles Pasqua 92300 Levallois-Perret France Phone: +33 1 58 63 16 00 Fax: +33 1 58 63 16 18

www.saft.com

24-32-10

10002
Apr 11/2023



COMPONENT MAINTENANCE MANUAL
4017CH-3

2. Numeric Index

PART NUMBER 09052	AIRLINE STOCK NUMBER	FIGURE NUMBER	ITEM NUMBER	UNIT	UNITS PER ASSY
MS21083C06 (09052 093169-000)			060	EA	2
MS3186A107W			070	EA	1
M25988-3-019			050	EA	1
009384-000			300	EA	1
012536-000			210	EA	1
015575-000			220	EA	14
015576-000			230	EA	3
015577-000			240	EA	2
015579-000			080, 110, 140	EA	82
015924-003			020	EA	1
015926-000			260	EA	1
015945-000			030	EA	1
016420-000			040	EA	1
016423-000			250	EA	1
019736-000			310	EA	1
021870-000			180	EA	2
021871-000			170	EA	4
022078-000			280	EA	1
022228-000			090, 120	EA	42
023388-001			160	EA	1
023388-002			150	EA	1
023619-000			200	EA	1
024313-000			100	EA	20
024643-000		1	-1	EA	RF
024644-000			010	EA	1
091181-002			190	EA	2
093616-000			290	EA	4

24-32-10

10003
Oct 5/2022

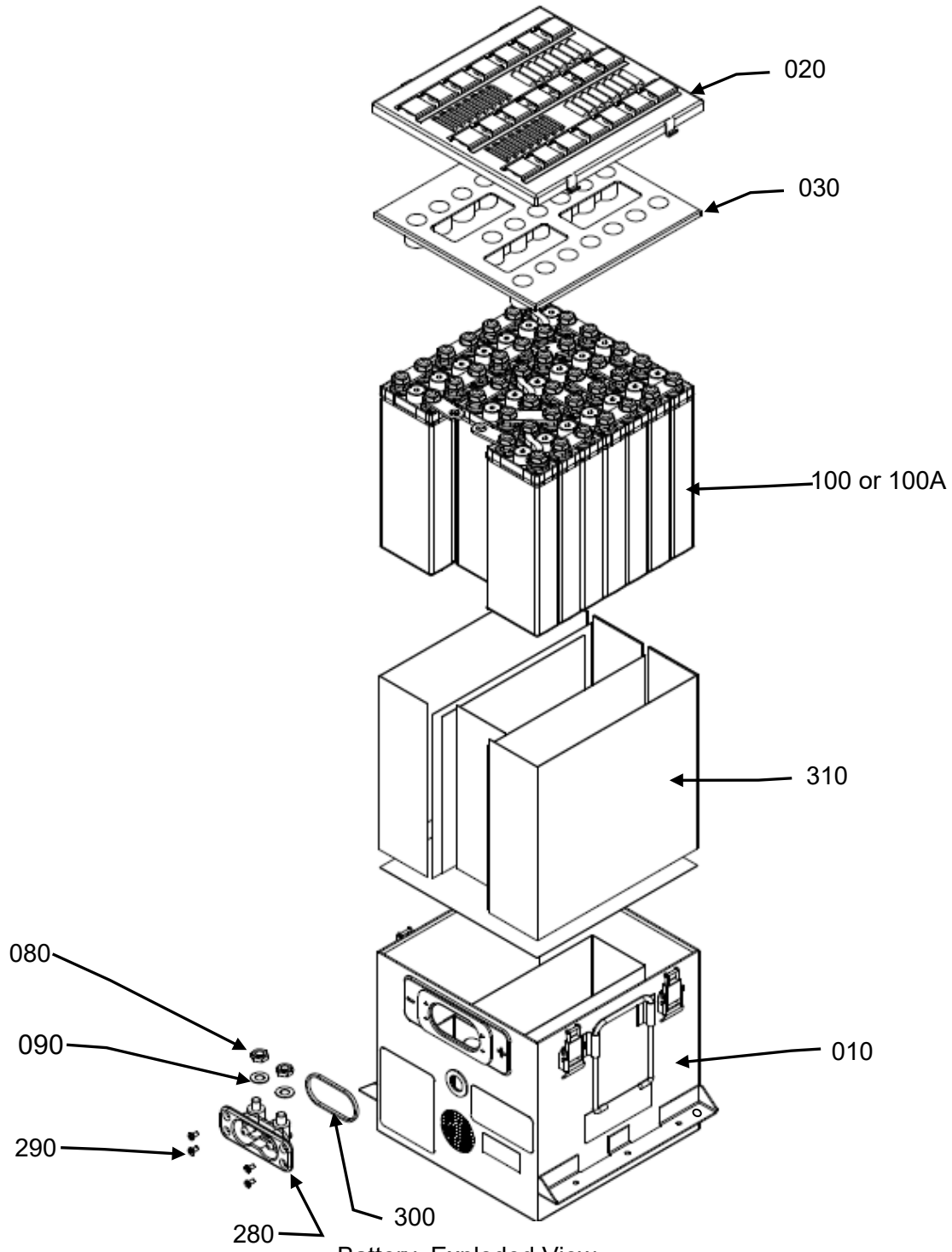

Battery, Exploded View
IPL Figure 1 (#1 of 4)

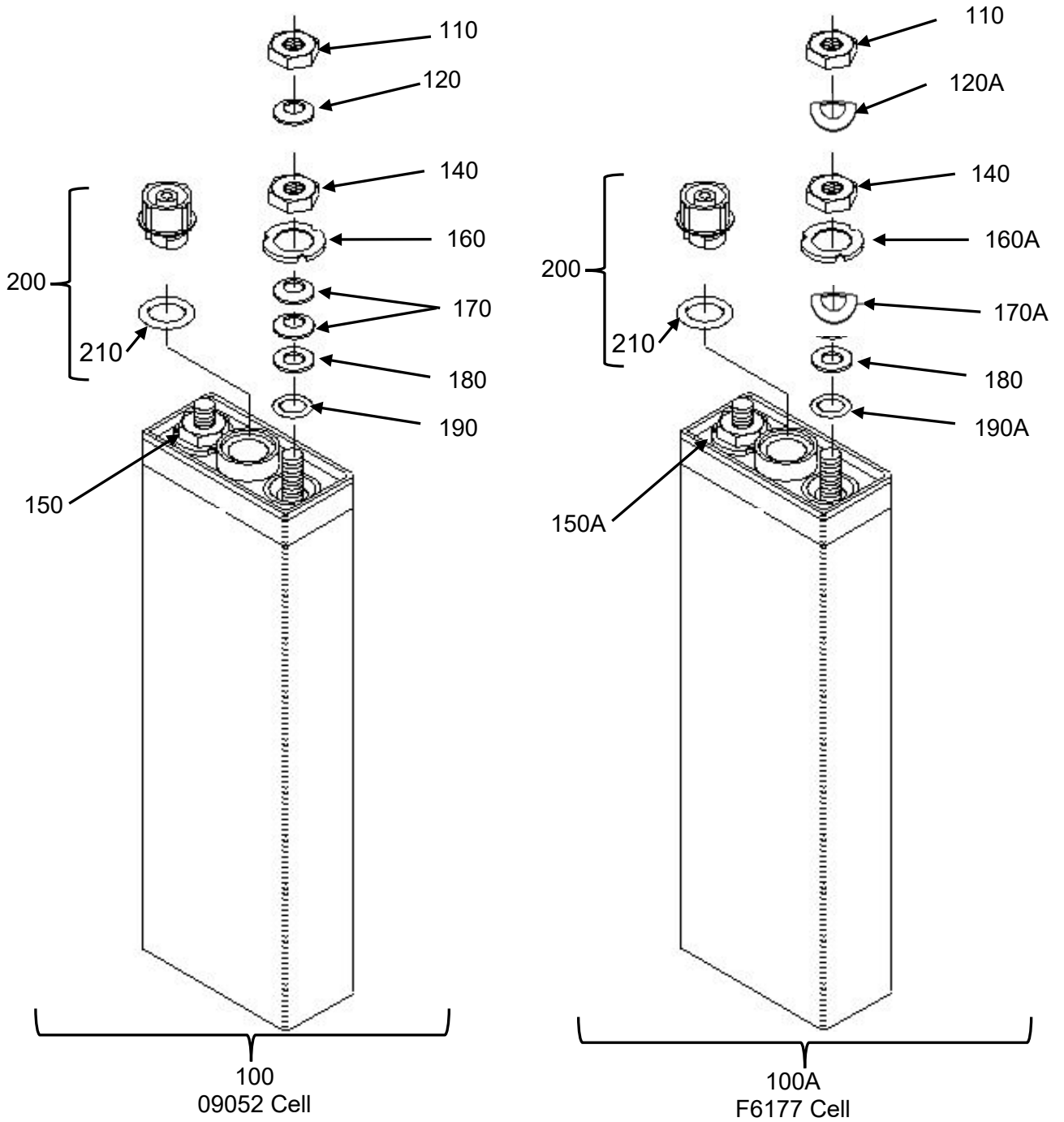

Battery, Exploded View
IPL Figure 1 (#2 of 4)

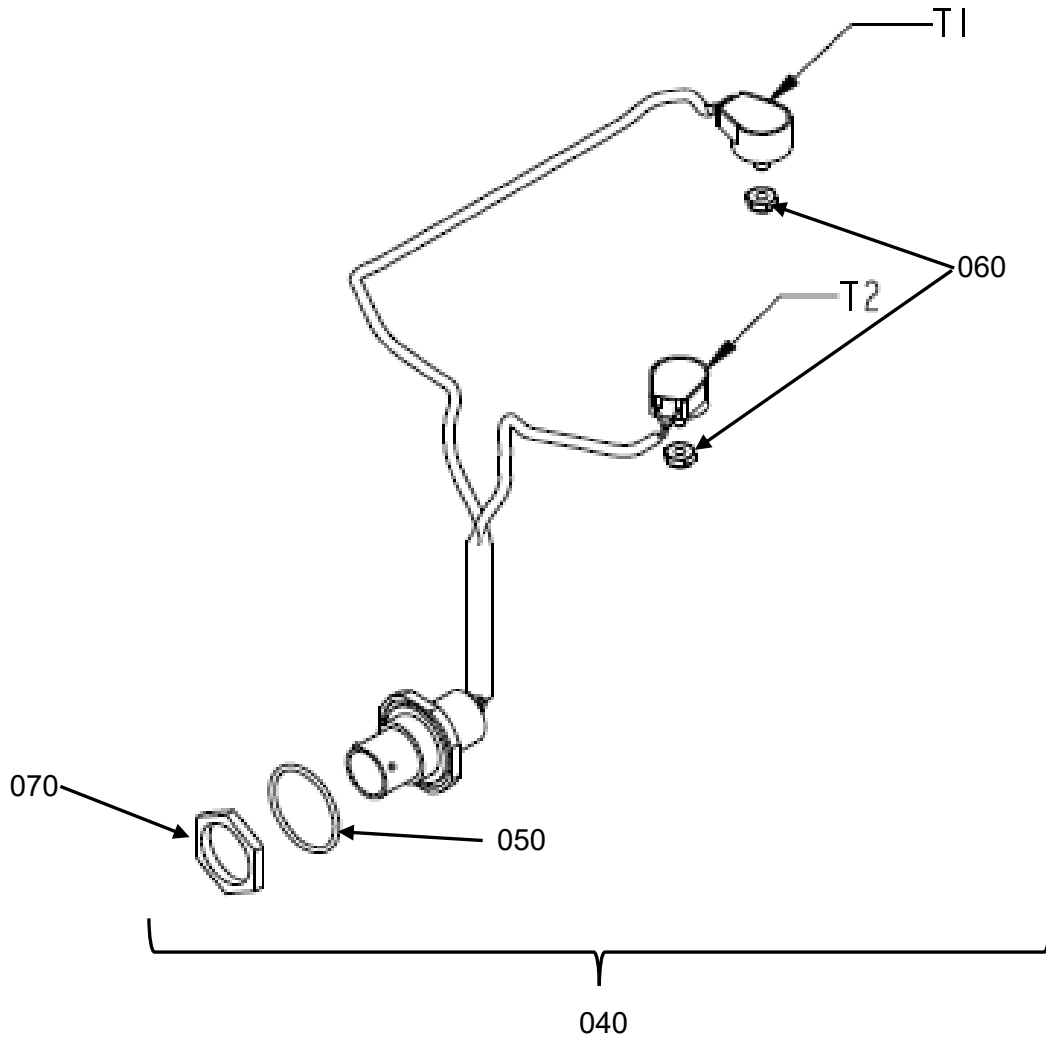

Battery, Exploded View
IPL Figure 1 (#3 of 4)

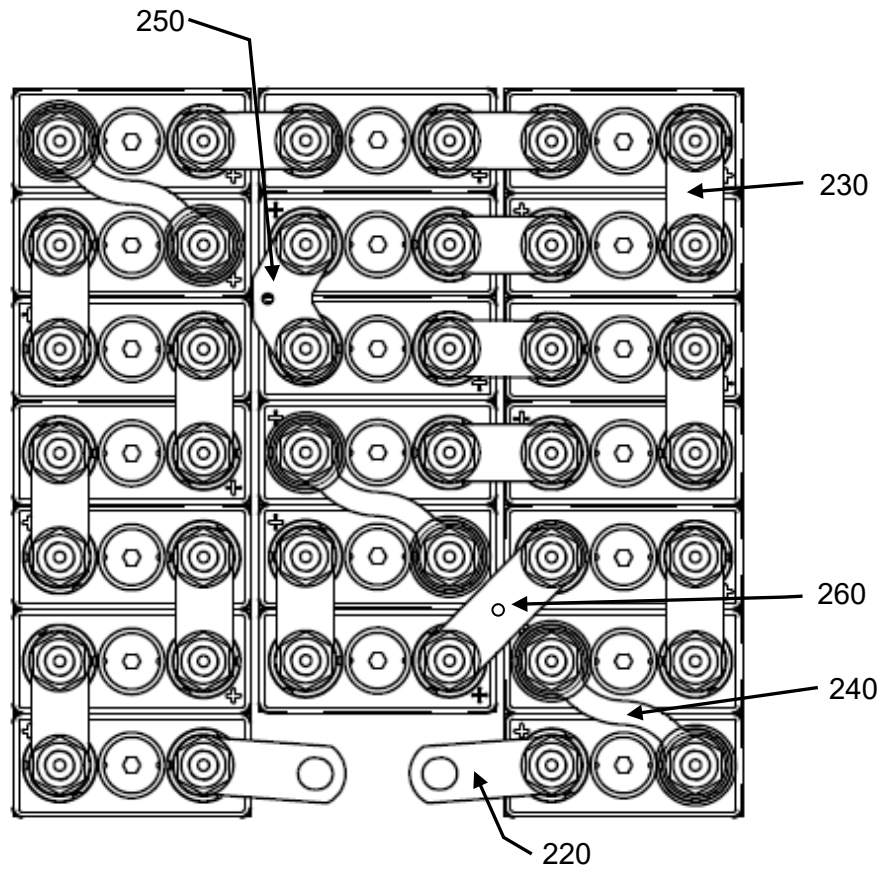

Battery, Exploded View
IPL Figure 1 (#4 of 4)



COMPONENT MAINTENANCE MANUAL
4017CH-3

3. Detail Parts List

FIGURE & ITEM	PART NUMBER		AIRLINE PART NO.	NOMENCLATURE 1234567	EFF CODE	UNITS PER ASSY
	09052	F6177				
1 -1	024643-000	-		BATTERY, 4017CH-3		RF
010	024644-000	-		. Case, Marked, 4017CH-3		1
020	015924-003	116996		. Cover		1
030	024646-000	-		. Pad, Holddown		1
040	016420-000	116109		. Sensor, Harness		1
050	M25988-3-019	-		. . O-Ring, Sensor M25988/3-019 (F6177 112967)		1
				Attaching Parts		
060	MS21083C06	-		. Nut, Thermostat (09052 093169-000) (F6177 105405)		2
070	MS3186A107W	-		. Nut, Sensor Connector (F6177 112965)		1
				* * *		
080	015579-000	062007		. Nut, Hex, Power Connector		2
090	022228-000	-		. Washer, Belleville		2
100	023413-000			. Cell, CVH400KA w/hardware		20
100A	-	413597		. Cell, CVH400KA w/hardware (OPT TO ITEM 100)		20
110	015579-000	062007		. . Nut, Hex, Upper		2
120	022228-000	-		. . Washer, Belleville		2
120A	-	100094		. Washer, Spring (OPT TO ITEM 120)		2
140	015579-000	062007		. . Nut, Hex, Lower		2
150	023388-002	-		. . Washer, Negative Polarity		1
150A	-	100693		. . Washer, Negative Polarity (OPT TO ITEM 150)		1
160	023388-001	-		. . Washer, Positive Polarity		1
160A	-	100694		. . Washer, Positive Polarity (OPT TO ITEM 160)		1
170	021871-000			. . Washer, Belleville		4
170A	-	100094		. . Washer, Spring (ALT TO ITEM 170)		2
180	021870-000	100078		. . Washer, Flat		2
190	091181-002			. . O-Ring, Terminal		2
190A	-	411647		. . O-Ring, Terminal (OPT TO ITEM 190)		2
200	023619-000	413600		. . Valve, Vent		1
210	012536-002	413604		. . . O-Ring, Vent-Valve		1
220	015575-000	012374		. Link		14
230	015576-000	057014		. Link		3
240	015577-000	015539		. Link		2
250	016423-000	116112		. Link		1

DASH (-) ITEM NOT ILLUSTRATED

24-32-10

10008
Oct 5/2022



COMPONENT MAINTENANCE MANUAL
4017CH-3

FIGURE & ITEM	PART NUMBER		AIRLINE PART NO.	NOMENCLATURE 1234567	EFF CODE	UNITS PER ASSY
	09052	F6177				
260	015926-000	114767		. Link		1
280	022078-000	102227		. Connector, Power		1
				Attaching Parts		
290	093616-000			. Screw, Sems, 8x32		4
				* * *		
300	009384-000			. Gasket, Power Connector		1
310	019736-000	412240		. Kit, Spacer		1

DASH (-) ITEM NOT ILLUSTRATED

24-32-10

10009
Oct 5/2022



COMPONENT MAINTENANCE MANUAL
4017CH-3

PAGE INTENTIONALLY LEFT BLANK

24-32-10

10010
Oct 5/2022



COMPONENT MAINTENANCE MANUAL
4017CH-3

STORAGE (INCLUDING TRANSPORTATION)

1. Introduction

- A. Storage preparation and packaging makes sure that the equipment is protected against any attack by atmospheric agents.
- B. For a battery which has been cleaned and serviced and is not directly put into service on board an aircraft, different methods can be recommended depending on the purpose and the environment conditions of the "storage".
- C. Keep the batteries and spares in a dry and clean room.

2. Inactive Long-Term Storage

A. Procedure

(1) The following must be done to any battery with prior service history.

(a) [Charge](#), [Electrolyte level](#), [Vent valve test](#), and [Capacity test](#).

NOTE: It is not necessary that it be short circuited. There is no need of maintenance operation during the storage period.

NOTE: The standard cardboard packaging is considered unsealed and allows 2 years of storage. Storage is allowed for 10 years if the following conditions are met: sealed packaging and isolated from harmful agents (i.e.: dirt, dust, vibrations, or corrosive atmosphere).

- sealed packaging,
- temperature: +5°C to +35°C (+41°F to +95°F),
- humidity < 90%,
- normal vertical position,
- Isolated from detrimental agents: i.e., dirt, dust, dampness, vibration, corrosive atmosphere.

(2) Saft Ni-Cd batteries may be stored in temperatures ranging from -55°C to +5°C or +35°C to +60°C (-67°F to +41°F or +95°F to +140°F) for an accumulated exposure that does not exceed 30 days.

(3) Lead batteries must not be stored in the same room.

B. Servicing at end of long-term storage

STORAGE TIME	SERVICE PROCEDURE
Less than or equal to 12 months	Do Visual Inspection , and return to Figure 1001 entry point " C "
More than 12 months	Do Charge and return to Figure 1001 entry point " Received "

Return to Service Following Storage
Table 15001

3. Inactive Standby Storage

The battery is charged after being serviced then stored fully charged in a dedicated room in such a way that it can be installed in the aircraft without further maintenance except as provided within this section. Refer to [Figure 15002](#).

NOTE: At any time during the inactive standby storage shown in [Figure 15002](#), the battery may be installed on the aircraft or placed into [Inactive Long-Term Storage](#).

NOTE: For a battery previously stored at a temperature below ambient temperature, condensation within the battery may occur, do [Battery insulation](#) before installation.

A. Standby period is the rest time that corresponds to 80% available capacity shown in [Figure 15001](#), example, 24 days at +30°C (+86°F).

NOTE: The maximum time for the standby period is 90 days for temperatures ≤ +23°C (+73°F).

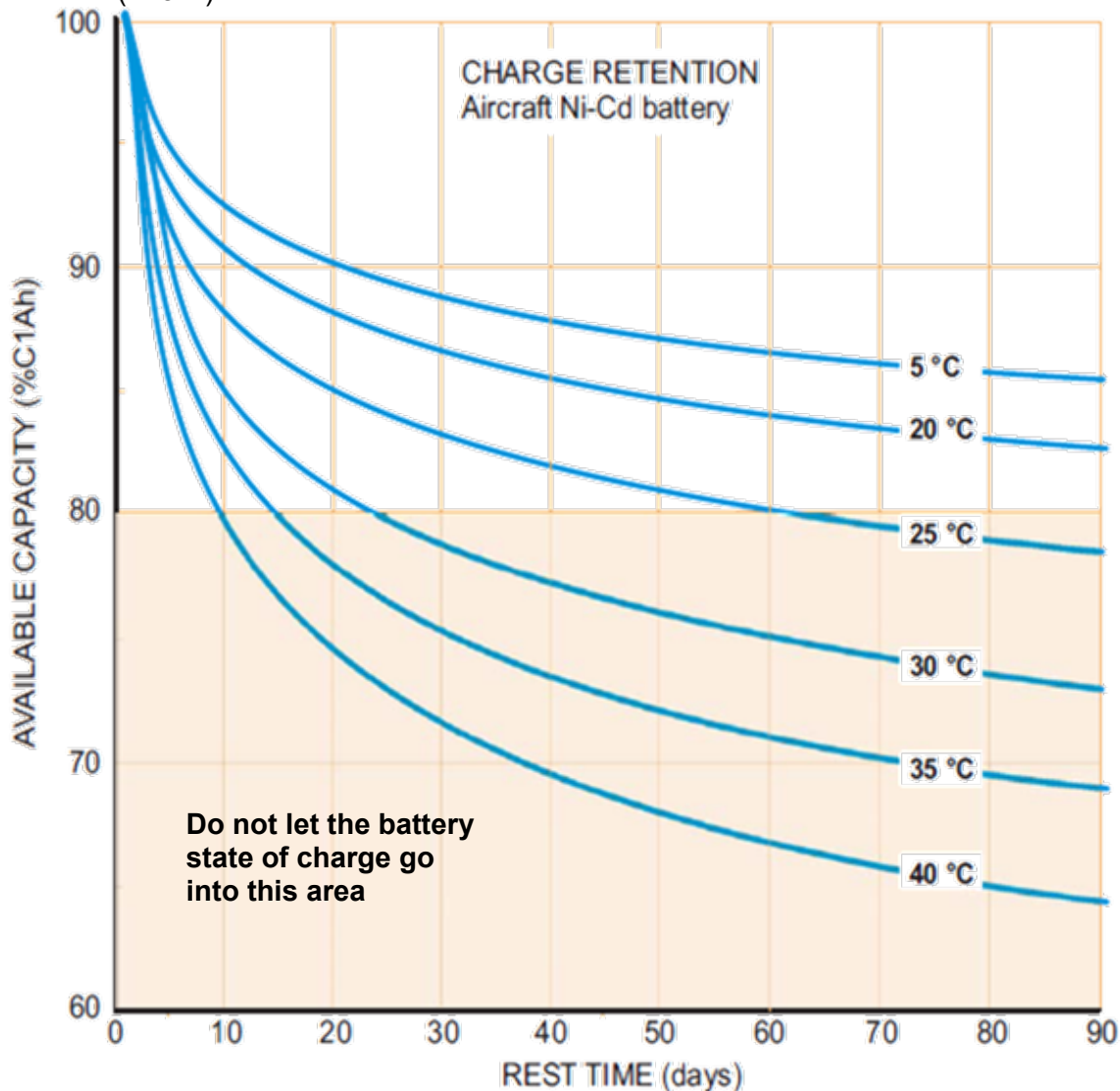

Standby Period
Figure 15001



COMPONENT MAINTENANCE MANUAL
4017CH-3

B. Refresh charge is a quick constant current charge that can be done at the end of a [Standby period](#) to extend the time the battery is in inactive standby storage. The charge is given in the [Table 15002](#).

CAUTION: DO NOT DO THE 4 HOURS FINAL CHARGE AT 0.1 C₁A (REFER TO [CHARGE](#)) DURING THIS 'REFRESH' CHARGE OPERATION.

CHARGE RATE	VOLTAGE (END OF "REFRESH" CHARGE)
0.1C ₁ A	30.0V for 20 Cells
0.5C ₁ A	31.0V for 20 Cells
1.0C ₁ A	31.4V for 20 Cells

Refresh Charge
Table 15002

- C. Standby duration consists of a maximum of 3 standby periods with 2 refresh charges. The number of consecutive standby durations is limited to 3. Refer to [Figure 15002](#).
- (1) For a battery completing the first or second standby duration and not immediately installed in the aircraft or sent into long-term storage, do the one of the following:
 - (a) For environments ≤ +30°C (+86°F) do [Battery insulation](#), [Initial discharge](#), [Charge](#), [Electrolyte level](#), and [Battery insulation](#).
 - (b) For environments > +30°C (+86°F) do [Battery insulation](#), [Initial discharge](#), [Cell shorting](#), [Charge](#), [Electrolyte level](#), and [Battery insulation](#).
 - (2) For a battery completing the third consecutive standby durations, the battery can go into [Inactive Long-Term Storage](#) or return to [Figure 1001](#).
- D. Inactive standby storage schedule is limited to the [Standby duration](#) being conducted a maximum of 3 times as shown in [Figure 15002](#).

NOTE: At any time during this inactive standby storage schedule shown in [Figure 15002](#), the battery may be installed on the aircraft or placed into [Inactive Long-Term Storage](#).

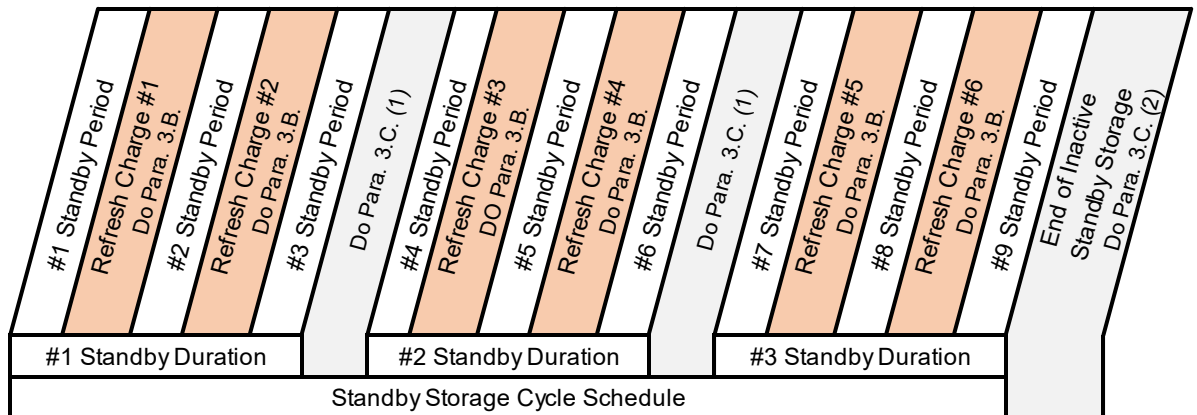

Inactive Standby Storage Schedule
Figure 15002



COMPONENT MAINTENANCE MANUAL
4017CH-3

4. Active Standby Mode (Trickle Charge)

CAUTION: WATER CONSUMPTION OCCURS WHEN THE BATTERY IS CONTINUOUSLY CHARGED, IN AN OVERCHARGE CONDITION. SAFT DOES NOT RECOMMEND THIS METHOD, HOWEVER SOME OPERATORS TAKE RESPONSIBILITY FOR ITS USE.

NOTE: This method is not reliable due to quantity and inaccuracy of water consumption.

Example: A 40 Ah battery on a continuous trickle charge of 3 mA/Ah for one month may consume over 35 cm³/cell (2.14 in³/cell) of water.

5. Storage of spare parts

A. Spare Cells

Spare cells must be stored in a vertical upright position, filled, and discharged condition (electrolyte levels are not visible in discharged cells). It is not necessary to short circuit the cells. The vent valves must be installed. The storage conditions are the same as those given in paragraph Inactive long-term storage. No maintenance operation is needed during storage. Before installation in a battery, cells must be visually inspected for damage or leakage and repaired as necessary in accordance with this CMM.

B. Spare O-rings, gaskets, and vent valves

(1) O-rings and gaskets

Six (6) years of storage period starts from the date of manufacture unless otherwise specified on the packaging. The O-rings and gaskets should be protected from exposure to the air, light, and high humidity < 85%. Storage life depends on temperature. It is recommended to store the parts in a cool area < +25°C (+77°F). Above +35°C (+95°F), storage life is reduced to 5 years. Before use the O-rings or gaskets it must be inspected. In case of visible signs of damage, distortion, or deterioration, the part must be discarded.

O-rings must be inspected before use and must be disregarded if there are visible signs of damage, distortion, or deterioration.

(2) Vent valves with O-rings

Six (6) years of storage period starts from the date of manufacture unless otherwise specified on the packaging. The vent valves and O-rings should be protected from exposure of air, light and high humidity (< 85%). Storage life depends on temperature. It is recommended to store the parts in a sealed container (non-PVC) in a cool area < +25°C (+77°F). Above +35°C (+95°F), storage life is reduced to 5 years. Before use the vent valves and O-rings it must be inspected. In case of visible signs of damage, deformation, or deterioration, the vent valve and O-ring must be discarded.

C. Other spares

Other spares, protected from external contamination (i.e. dirt, dust, dampness, vibration, corrosive atmosphere) and high humidity (> 85%), may be stored for unlimited periods. Before use, they must be inspected and any showing visible signs of damage, distortion or deterioration must be discarded.

24-32-10

15004
Apr 11/2023



COMPONENT MAINTENANCE MANUAL
4017CH-3

6. Transportation procedure

The battery is normally discharged before packing. If it is necessary to transport a charged battery, make sure that the output terminals are protected against short circuit.

The battery should then be packed vertically in its original container. If the original container is not available, the international and/or local packaging regulations applicable to the mode of transport and destination must be followed.

According to the IATA / IMDG dangerous goods regulations, Saft ships all existing nickel cadmium batteries or cells for aircraft under the classification UN2795 (wet, filled with alkali).

24-32-10

15005
Apr 11/2023



COMPONENT MAINTENANCE MANUAL
4017CH-3

PAGE INTENTIONALLY LEFT BLANK

24-32-10

15006
Apr 11/2023