



**To:** HOLDERS OF COMPONENT MAINTENANCE MANUAL 24-32-03 40176-4 and 40176-7

**Subject:** CMM Revision No. 4 Dated Aug 4/21

Replace revised pages by adding and removing pages for pages dated Aug 4/21

**NOTE:** The CMM can be downloaded from the internet at [www.saftbatteries.com](http://www.saftbatteries.com)

**HIGHLIGHTS**

<b>CHAPTER/SECTION PAGE NUMBER</b>	<b>DESCRIPTION OF CHANGE</b>
All	Total rewrite and reorganization



ECCN: EAR99  
Cage Code 09052  
711 GIL HARBIN INDUSTRIAL BOULEVARD  
VALDOSTA, GEORGIA 31601  
Phone: +1 (229) 247-2331 Fax: +1 (229) 247-8486

# **COMPONENT MAINTENANCE MANUAL WITH ILLUSTRATED PARTS LIST**

## **Nickel Cadmium Aircraft Batteries**

**Saft Model  
40176-4 / 40176-7**

**Website: [www.saftbatteries.com](http://www.saftbatteries.com)**

**24-32-03**

T-1  
REV 4 Aug 4/21



COMPONENT MAINTENANCE MANUAL  
40176-4 / 40176-7

This document and all information contained herein are the property of Saft. Its use is restricted solely to the maintenance of Saft batteries and may under no circumstances be used for any other manufacturer's products. No person may, in whole or in part, duplicate, use or disclose this information for any other purpose without the prior written consent of Saft.

**24-32-03**

T- 2  
Aug 4/21



COMPONENT MAINTENANCE MANUAL  
40176-4 / 40176-7

**RECORD OF REVISIONS**

REV NO.	ISSUE DATE	INSERT DATE	BY	REV NO.	ISSUE DATE	INSERT DATE	BY
1	07/30/75	07/30/75	Saft				
2	09/30/98	09/30/98	Saft				
3	04/15/02	04/15/02	Saft				
4	Aug 4/21	Aug 4/21	Saft				



COMPONENT MAINTENANCE MANUAL  
40176-4 / 40176-7

PAGE INTENTIONALLY LEFT BLANK

**24-32-03**

Blank  
Aug 4/21



COMPONENT MAINTENANCE MANUAL  
40176-4 / 40176-7

**RECORD OF TEMPORARY REVISIONS**

<b>TEMPORARY REV NO</b>	<b>PAGE NUMBER</b>	<b>ISSUE DATE</b>	<b>BY</b>	<b>DATE</b>	<b>BY</b>

**24-32-03**



COMPONENT MAINTENANCE MANUAL  
40176-4 / 40176-7

PAGE INTENTIONALLY LEFT BLANK

**24-32-03**

Blank  
Aug 4/21



COMPONENT MAINTENANCE MANUAL  
40176-4 / 40176-7

**SERVICE BULLETIN LIST**

NUMBER	BRIEF DESCRIPTION	TYPE AFFECTED

**PRODUCT IMPROVEMENTS**

Product Improvements have been incorporated using service bulletins entered in the service bulletin list. Service bulletin highlights are as follows:

**24-32-03**

SBL 1  
Aug 4/21





COMPONENT MAINTENANCE MANUAL  
40176-4 / 40176-7

PAGE INTENTIONALLY LEFT BLANK

**24-32-03**

Blank  
Aug 4/21



COMPONENT MAINTENANCE MANUAL  
40176-4 / 40176-7

**LIST OF EFFECTIVE PAGES**

<u>SUBJECT</u>	<u>PAGE</u>	<u>DATE</u>
TITLE PAGE	T-1 T-2	Aug 4/21 Aug 4/21
RECORD OF REVISIONS	ROR 1 ROR 2	Aug 4/21 Blank
RECORD OF TEMPORARY REVISIONS	RTR 1 RTR 2	Aug 4/21 Blank
SERVICE BULLETIN LIST	SBL-1 SBL-2	Aug 4/21 Blank
LIST OF EFFECTIVE PAGES	LEP 1 LEP 2	Aug 4/21 Blank
TABLE OF CONTENTS	TOC 1 TOC 2	Aug 4/21 Blank
LIST OF ILLUSTRATIONS	LOI 1 LOI 2	Aug 4/21 Blank
LIST OF TABLES	LOT 1 LOT 2	Aug 4/21 Blank
INTRODUCTION	Intro 1 Intro 2 Intro 3 Intro 4	Aug 4/21 Aug 4/21 Aug 4/21 Aug 4/21
DESCRIPTION AND OPERATION	1 2 3 4	Aug 4/21 Aug 4/21 Aug 4/21 Blank
TESTING AND FAULT ISOLATION	1001 1002 1003 1004 1005 1006 1007 1008 1009 1010 1011 1012 1013 1014 1015 1016 1017 1018	Aug 4/21 Aug 4/21 Aug 4/21 Aug 4/21 Aug 4/21 Aug 4/21 Aug 4/21 Aug 4/21 Aug 4/21 Aug 4/21 Aug 4/21 Aug 4/21 Aug 4/21 Aug 4/21 Aug 4/21 Aug 4/21 Aug 4/21 Blank

<u>SUBJECT</u>	<u>PAGE</u>	<u>DATE</u>
DISASSEMBLY	3001 3002	Aug 4/21 Blank
CLEANING	4001 4002	Aug 4/21 Aug 4/21
CHECK	5001 5002	Aug 4/21 Aug 4/21
REPAIR	6001 6002 6003 6004	Aug 4/21 Aug 4/21 Aug 4/21 Aug 4/21
ASSEMBLY	7001 7002 7003 7004	Aug 4/21 Aug 4/21 Aug 4/21 Aug 4/21
FITS AND CLEARANCES	8001 8002	Aug 4/21 Blank
SPECIAL TOOLS, FIXTURES, EQUIPMENT, AND CONSUMABLES	9001 9002	Aug 4/21 Aug 4/21
ILLUSTRATED PARTS LIST	10001 10002 10003 10004 10005 10006 10007 10008	Aug 4/21 Aug 4/21 Aug 4/21 Aug 4/21 Aug 4/21 Aug 4/21 Aug 4/21 Aug 4/21
STORAGE (INCLUDING TRANSPORTATION)	15001 15002 15003 15004	Aug 4/21 Aug 4/21 Aug 4/21 Aug 4/21

**24-32-03**

LEP 1  
Aug 4/21



COMPONENT MAINTENANCE MANUAL  
40176-4 / 40176-7

PAGE INTENTIONALLY LEFT BLANK

**24-32-03**

Blank  
Aug 4/21



COMPONENT MAINTENANCE MANUAL  
40176-4 / 40176-7

**TABLE OF CONTENTS**

<b>PARAGRAPH TITLE</b>	<b>PAGE</b>
INTRODUCTION	<a href="#">Intro 1</a>
DESCRIPTION AND OPERATION	<a href="#">1</a>
TESTING AND FAULT ISOLATION	<a href="#">1001</a>
AUTOMATIC TEST REQUIREMENTS (ATLAS)	N/A
DISASSEMBLY	<a href="#">3001</a>
CLEANING	<a href="#">4001</a>
CHECK	<a href="#">5001</a>
REPAIR	<a href="#">6001</a>
ASSEMBLY	<a href="#">7001</a>
FITS AND CLEARANCES	<a href="#">8001</a>
SPECIAL TOOLS, FIXTURES, EQUIPMENT, AND CONSUMABLES	<a href="#">9001</a>
ILLUSTRATED PARTS LIST	<a href="#">10001</a>
STORAGE (INCLUDING TRANSPORTATION)	<a href="#">15001</a>

**24-32-03**

TOC 1  
Aug 4/21



COMPONENT MAINTENANCE MANUAL  
40176-4 / 40176-7

PAGE INTENTIONALLY LEFT BLANK

**24-32-03**

Blank  
Aug 4/21



COMPONENT MAINTENANCE MANUAL  
40176-4 / 40176-7

**LIST OF ILLUSTRATIONS**

FIGURE	DESCRIPTION	PAGE
Intro 1	Universal Recycling Symbols	<a href="#">Intro 4</a>
1	40176-4 and 407176-7 Nickel Cadmium Battery	<a href="#">1</a>
1001	Periodical Check	<a href="#">1002</a>
1002	Regular Check	<a href="#">1003</a>
1003	General Overhaul	<a href="#">1004</a>
1004	Position of <a href="#">T02</a> in Cell Vent Seal	<a href="#">1010</a>
1005	Connector Pinout	<a href="#">1011</a>
1006	Special Testing Flow Chart	<a href="#">1014</a>
7001	Spacer Kit ( <a href="#">310</a> ) Installation	<a href="#">7002</a>
7002	Cell Number, Polarity and Sensor Orientation	<a href="#">7003</a>
7003	Sensor Harness Routing	<a href="#">7004</a>
1	Battery, Exploded View Battery (Sheet 1 of 4)	<a href="#">10004</a>
1	Battery, Exploded View Battery (Sheet 2 of 4)	<a href="#">10005</a>
1	Battery, Exploded View Battery (Sheet 3 of 4)	<a href="#">10006</a>
1	Battery, Exploded View Battery (Sheet 4 of 4)	<a href="#">10007</a>
15001	Inactive Standby Period	<a href="#">15002</a>
15002	Inactive Standby Storage Schedule	<a href="#">15004</a>

**24-32-03**

LOI 1  
Aug 4/21



COMPONENT MAINTENANCE MANUAL  
40176-4 / 40176-7

PAGE INTENTIONALLY LEFT BLANK

**24-32-03**

Blank  
Aug 4/21



COMPONENT MAINTENANCE MANUAL  
40176-4 / 40176-7  
**LIST OF TABLES**

<b>TABLE</b>	<b>DESCRIPTION</b>	<b>PAGE</b>
1	Leading Particulars	<a href="#">2</a>
1001	Initial Discharge (Off-Wing Capacity)	<a href="#">1007</a>
1002	Charge Table	<a href="#">1008</a>
1003	Final Charge Voltage Limit	<a href="#">1008</a>
1004	Capacity Test (Second Discharge)	<a href="#">1011</a>
1005	Sensor Values	<a href="#">1012</a>
1006	Battery Faults	<a href="#">1015</a>
1007	Cell Faults	<a href="#">1016</a>
1008	Physical Faults	<a href="#">1017</a>
8001	Torque Values	<a href="#">8001</a>
9001	Special Tools	<a href="#">9001</a>
9002	Consumables	<a href="#">9002</a>
15001	Return to Service Following Storage	<a href="#">15001</a>
15002	Refresh Charge	<a href="#">15003</a>

**24-32-03**

LOT 1  
Aug 4/21





COMPONENT MAINTENANCE MANUAL  
40176-4 / 40176-7

PAGE INTENTIONALLY LEFT BLANK

**24-32-03**

Blank  
Aug 4/21



## COMPONENT MAINTENANCE MANUAL

40176-4 / 40176-7

### INTRODUCTION

#### 1. General

- A. This manual is written to the ATA Specification 100 and in AECMA Simplified English. International Standard units of measure are used in this manual, with imperial units in parentheses.
- B. This manual describes maintenance on components in a workshop. It does not describe maintenance on components when they are installed in aircraft.
- C. Only approved personnel with the necessary skill can do maintenance tasks described in this manual.
- D. This manual contains:
  - (1) Technical data for components
  - (2) Maintenance and replacement procedures for components
  - (3) An Illustrated Parts List (IPL) with data for parts of components. Parts are identified in all sections of the manual by IPL figure and item number.
- E. We make sure of DISASSEMBLY, TESTING AND FAULT ISOLATION, and ASSEMBLY procedures are correct by doing them.  
The manual is divided into separate sections:
  - (1) Title Page
  - (2) Record of Revisions
  - (3) Record of Temporary Revisions
  - (4) List of Effective Pages
  - (5) Table of Contents
  - (6) Introduction
  - (7) Procedures and IPL Sections

The disassembly and assembly sections contain only specific instructions used on the equipment covered herein. Most standard aerospace practices are not described herein.

This manual provides the information necessary for an experienced shop technician to maintain Saft nickel-cadmium batteries. It describes construction of the battery, as well as techniques used to operate, maintain, and provide care for the battery. Following these instructions will enhance the ability to obtain optimum performance and maximum life from Saft batteries.

All aircraft batteries require checking and maintenance to make sure they are safe when installed and they perform their required functions especially in emergency conditions on board the aircraft. Maintenance allows problems to be identified and corrected. The maintenance interval is the period for which correct operation is assured with a low probability of failure and allows high levels of MTBUR and MTBF.

Every effort has been made to provide complete and accurate instructions. If a situation should arise that is not adequately described in this manual, please contact Saft via the internet at [www.saftbatteries.com](http://www.saftbatteries.com) or at one of the following addresses:

# 24-32-03

Intro 1  
Aug 4/21



COMPONENT MAINTENANCE MANUAL  
40176-4 / 40176-7

Saft America Inc. (V09052)  
711 Gil Harbin Industrial Boulevard  
Valdosta, GA 31601, USA

Saft (F6177)  
126 quai Charles Pasqua  
92300 Levallois-Perret, France

Phone: +1 (229) 247-2331  
Fax: +1 (229) 247-8486

Phone: +33 1 58 63 16 00  
Fax: +33 1 58 63 16 18

2. Definitions

Warnings call attention to use of materials, procedures, or limits which must be followed precisely to avoid injury to persons.

Cautions call attention to procedures which should be followed to avoid damage to equipment.

Notes call attention to procedures which make the job easier.

3. Safety

**WARNING:** EXCEPT FOR THOSE STEPS THAT REQUIRE THE BATTERY TO BE CHARGED, DO ALL STEPS ON DISCHARGED BATTERIES (REFER TO [INITIAL DISCHARGE](#) AND [CELL SHORTING](#)) TO AVOID THE POSSIBILITY OF ELECTRIC SHOCK. FINGER TIGHTEN VENT VALVES ([200](#)) WITH [T01](#) PRIOR TO BEGINNING DISCHARGE. BATTERY CELLS DELIVER VERY HIGH CURRENT WHEN SHORT-CIRCUITED. EXERCISE CAUTION. REMOVE RINGS, WATCHES, NECKLACES, METALLIC BELTS AND OTHER JEWELRY TO AVOID ELECTRIC SHOCK.

**WARNING:** DO NOT TILT THE BATTERY DURING MAINTENANCE, ANY CONTACT OF SKIN WITH ELECTROLYTE CAN CAUSE SEVERE BURNS.

Safety rules differ from one country to another. Always follow local safety regulations.

There are three types of risks

A. Physical

- (1) Handling: the battery is heavy. When you lift it, bend your legs and not your back.
- (2) Use protective shoes.

B. Electrical

- (1) Do not wear rings, watches, chains, belt buckles, necklaces, or any other metallic objects.
- (2) Use insulated tools.

C. Chemical

- (1) For a complete listing of hazards, refer to the safety information sheet available on Saft's website at [www.saftbatteries.com](http://www.saftbatteries.com).
- (2) Electrolyte is very corrosive and can damage the skin: use gloves and an apron. If it touches the skin, flush affected part with large quantity of water. Remove contaminated clothing, after flushing begins.

**24-32-03**

Intro 2  
Aug 4/21



## COMPONENT MAINTENANCE MANUAL

40176-4 / 40176-7

- (3) Electrolyte is very dangerous for eyes, use protective goggles. If the electrolyte comes in contact with an eye, flush it with water and get immediate medical attention.
- (4) Saft recommends the use of an amphoteric solution (both acidic and basic behavior) and chelator (able to trap cations as a chelate complex) to neutralize electrolyte according to the local regulation.
- (5) Electrolyte ingestion can cause damage to the throat and respiratory tract. Do not try to vomit and get immediate medical attention.
- (6) Skin contact with nickel can cause chronic eczema.
- (7) Inhalation of cadmium oxide can cause dry throat, headaches, vomiting, chest pain. If inhaled, move to fresh air. If not breathing, give artificial respiration. If breathing is difficult, give oxygen and get immediate medical attention.

#### 4. New Battery Commissioning

**NOTE:** Whether or not the battery has been subject to disassembly and reassembly, before going into service and installation, the tightness of all upper nuts / screws must be checked to confirm that torque values correspond with those specified in [Table 8001](#).

Saft batteries are shipped discharged. Refer to [Initial New Battery Commissioning](#).

All new Saft batteries that are receiving the initial commissioning within 12 months of the DOM refer to [Initial New Battery Commissioning](#) on page [5001](#) to place into service.

For all new Saft batteries that have not received an initial commissioning within 12 months of the DOM, then refer to [Servicing at end of long-term storage](#), [Table 15001](#).

#### 5. Battery Ratings

##### A. Capacity

Nickel-cadmium batteries are rated in terms of capacity in ampere-hours (Ah) (rated capacity).

Other definitions for battery ratings can be found in EN2570, IEC 60952, and RTCA DO 293.

#### 6. Recycling

All batteries eventually lose their ability to perform and are eligible for scrapping and recycling. Saft takes environmental matters seriously and advocates proper recycling of nickel-cadmium batteries and their components. To that end, Saft operates recycling facilities in both Europe and North America.

Nickel-cadmium batteries contain nickel, cadmium, and potassium hydroxide and should be disposed of properly. In all cases, rely on local and national regulations for proper battery disposal and/or shipping to an appropriate recycling location.

**24-32-03**

Intro 3  
Aug 4/21



Universal Recycling Symbols  
Figure Intro 1

You can find the nearest recycling collection point on our website at [www.saftbatteries.com](http://www.saftbatteries.com).

## 7. End of Life

EASA and FAA regulations “Part 145” requires end of life cells to be disposed of in a manner prohibiting them to be returned to service. Other authorities may have requirements less explicit, Saft recommends the following procedure to be followed to provide a means of compliance.

- A. Make sure the appropriate protective measures (refer to [Safety](#) paragraph and Battery Information Sheet (BIS)) are taken.
- B. Make sure the cell is fully discharged (see [Cell shorting](#)).
- C. Put one of the terminals from the cell into a bench vice and bend the terminal until it breaks. If any electrolyte leakage occurs, make sure the cleaning procedures are correctly applied (see Battery Information Sheet (BIS)).
- D. Dispose of the cell in accordance with applicable transport, health and safety, and recycling regulations. Refer to [Recycling](#) paragraph

All batteries eventually lose their ability to perform and are eligible for scrapping and recycling. Saft takes environmental matters seriously and advocates proper recycling of nickel-cadmium batteries and their components. To that end, Saft operates recycling facilities in both Europe and North America.

## 8. Abbreviations

A	Amperes
AECMA	European Association of Aerospace Industries
ATA	Air Transport Association of America
EASA	European Air Safety Authority
FAA	Federal Aviation Authority
IATA	International Transport Air Association
IMDG	International Maritime Dangerous Goods
IPL	Illustrated Parts List
MTBF	Mean Time Between Failure
MTBUR	Mean Time Between Unscheduled Removal
P/N	Part Number
V	Voltage



COMPONENT MAINTENANCE MANUAL  
40176-4 / 40176-7

**DESCRIPTION AND OPERATION**

1. Description

The Nickel Cadmium Battery provides power either to the standby system or to start the auxiliary power unit (APU). It is a nickel-cadmium type with sintered plate construction and uses a potassium hydroxide electrolyte. The battery consists of a case and cover, 20 cell assemblies, and a harness assembly. The sensor harness for the 40176-4 contains one thermostat (T1), and for the 40176-7 contains two thermostats (T1 and T2). Each sensor harness is mounted on link(s) inside the battery.

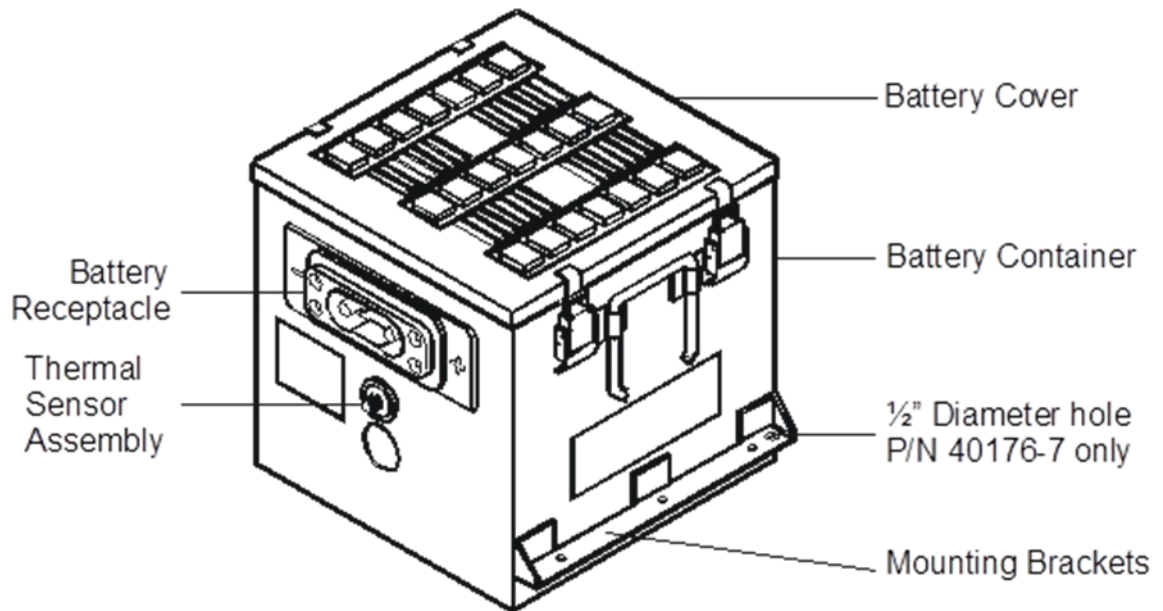

40176-4 and 40176-7 Nickel Cadmium Battery  
Figure 1



COMPONENT MAINTENANCE MANUAL  
40176-4 / 40176-7

PARAMETER	VALUES
Voltage: Nominal	24 Volts
Weight	37.7 kg (83.0 lbs)
Dimensions (Maximum): Height Length Width	256 mm (10.08 in) 248 mm (7.76 in) 264 mm (10.39 in)
Cell Assembly Terminal	M10 X 1.25, externally threaded
Number of Cell Assemblies	20
Cell Model	VP400KH
1.0C <sub>1</sub> A Rate	36A
0.5C <sub>1</sub> A Rate	18.0A
0.1C <sub>1</sub> A Rate	3.6A
Rated Capacity (C <sub>1</sub> )	36 Ampere-hours at 1.0C <sub>1</sub> A
Vent valve	M8 X 1.00 thread
Venting Pressure	0.14 to 0.69 bar (2 to 10 psi)
Consumable volume of water per cell	25 cm <sup>3</sup> (1.53 in <sup>3</sup> )
Cell Assembly Case Material	Polyamide
Battery Case Material	Stainless Steel
Electrolyte	Potassium Hydroxide
Recommended Storage Temperatures	+5°C to +35°C (+41°F to +95°F)
Ambient Temperature	+15°C to +30°C (+59°F to +86°F)

Leading Particulars  
Table 1

2. Operation

A. Flight charging

The battery is charged on the aircraft by an on-board charger.

B. Maintenance

(1) Maintenance interval basis

The aircraft manufacturer and/or operator is responsible for the definition of the maintenance interval based on the use profile of the batteries installed on aircraft. The maintenance interval has two main factors:

- Energy available for emergency requirements
- Electrolyte consumable reserve.



## COMPONENT MAINTENANCE MANUAL

40176-4 / 40176-7

Both factors depend on the battery charging system, operating temperature, loads provided, number of uses, flight duration, ground operation, and battery technology.

The higher voltage per cell applied, the higher overcharge current and capacity the battery receives.

The overcharged capacity is directly related to the electrolysis of water from the electrolyte, and hence the consumption of the electrolyte reserve. For every 3 Ah of overcharge, 1 cm<sup>3</sup> (0.061 in<sup>3</sup>) of water is consumed via electrolysis. Once the water reserve has been consumed, the result is:

- Dried out cells with a significant risk of permanent damage
- Internal short circuit
- Overheating
- Thermal runaway.

### (2) Maintenance interval extensions

To validate maintenance interval extension, the recommendation is for the Operator and Saft review the maintenance records for a minimum period of 12 months.

The data includes but is not limited to the recording of aircraft flight hours accrued while installed, its removal date, inspection date, off-wing capacity, and water consumption as required by this CMM.

As with any maintenance extension, subsequent monitoring of the water addition and electrical performance upon removal from the aircraft must be done to detect any adverse effects and, if necessary, re-adjust the maintenance interval accordingly.

### C. Battery data requirements

Maintenance information is required for any Saft battery evaluation to determine its condition and health. Throughout this manual there are multiple steps requiring specific information be recorded to maintain a battery service history. The information provided not will only reflect the batteries airworthiness, but also provide information to assist in any battery issue investigations required at the factory. As a minimum the items identified below are required for each battery maintenance step/action.

- (1) Record the date the battery was received, and time testing started.
- (2) As required for all discharges, record the duration the first cell reaches 1.0V.
- (3) As required during charges,
  - (a) Record the cell voltages at the start of the charge, at the end of the main charge, and the last 30 minutes of the final charge.
  - (b) Record the water added to each cell during the last 30 minutes of the overcharge.
- (4) As required for special testing, record location and reason for cell replacement either voltage or capacity.
- (5) Record the date the battery is returned to service.

**24-32-03**





COMPONENT MAINTENANCE MANUAL  
40176-4 / 40176-7

PAGE INTENTIONALLY LEFT BLANK

**24-32-03**

Blank  
Aug 4/21



COMPONENT MAINTENANCE MANUAL  
40176-4 / 40176-7  
**TESTING AND FAULT ISOLATION**

1. General

This section contains battery functional tests and fault isolation information. Test procedures are written in step-by-step formats that follow the process flow outlined in [Figure 1001](#), [Figure 1002](#), or [Figure 1003](#). Fault isolation [Table 1006](#), [Table 1007](#), and [Table 1008](#) identifies faults, possible causes, and remedies.

**NOTE:** The ( ) part identification numbers herein are IPL [Figure 1](#) item numbers.

**NOTE:** All voltage readings are DC unless otherwise stated.

2. Required Test Equipment

**NOTE:** Test equipment with equivalent specifications can be used.

Refer to [Special Tools, Fixtures, Equipment, and Consumables](#) for listing of Standard Tools.

3. Maintenance Procedures

In addition to the checks specified for airborne or ground use, in normal service SAFT 40176-4 / 40176-7 batteries require the following maintenance operations:

**NOTE:** Unless the maintenance has been previously increased or the air manufacturer states a different value, the following are provided as guidelines.

**NOTE:** These periods are given as an indication; modify in accordance with operational experience.

**NOTE:** Periodical and Regular Check may be combined if operating hours do not meet times listed.

A. Periodical check

If the electrolyte consumption exceeds the maximum consumable amount between two Regular Checks, this Periodical Check per [Figure 1001](#) may be done to adjust the electrolyte and prevent damage to the cells.

B. Regular check

Perform [Figure 1002](#) according to the aircraft manufacture or operator maintenance requirements. If these are not available, then it is recommended to perform this check every six months. To adjust this interval refer [Maintenance interval extensions](#).

C. General overhaul

Perform [Figure 1003](#) according to the aircraft manufacture or operator maintenance requirements or when required by [Figure 1001](#) or [Figure 1002](#).

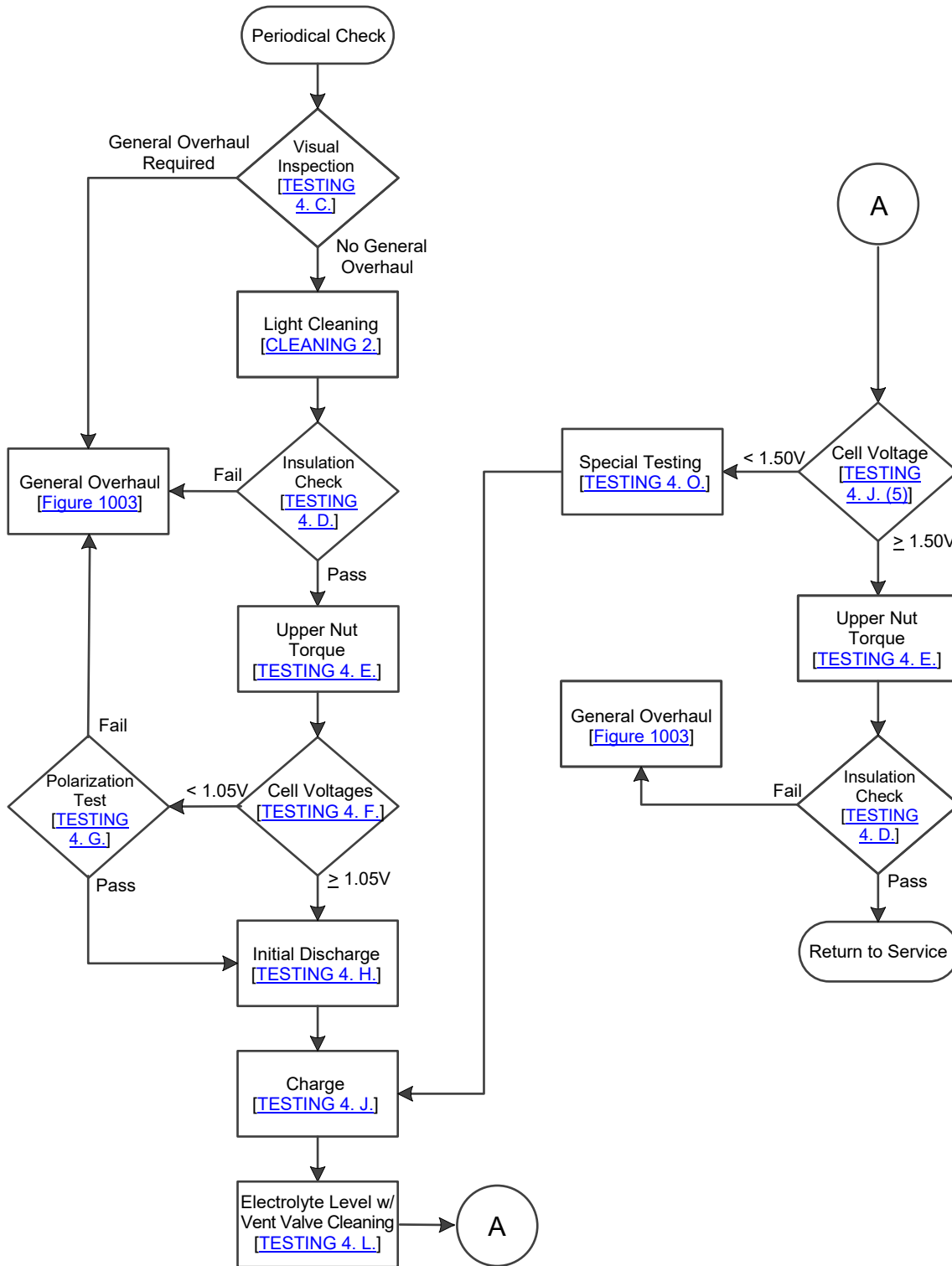

Periodical Check  
Figure 1001

## COMPONENT MAINTENANCE MANUAL 40176-4 / 40176-7

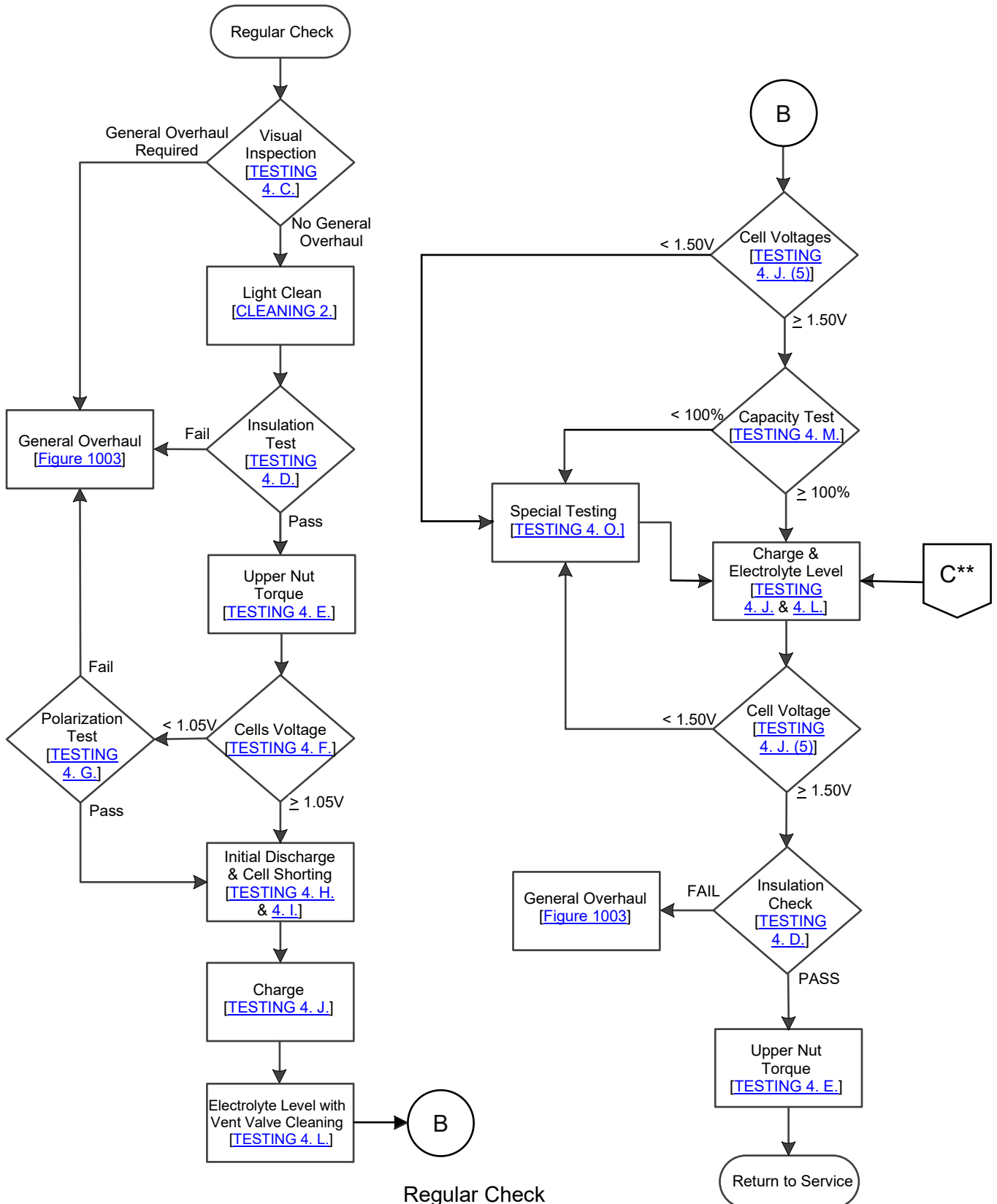

Regular Check  
Figure 1002

\*\*From Table 15001

**24-32-03**

1003  
Aug 4/21

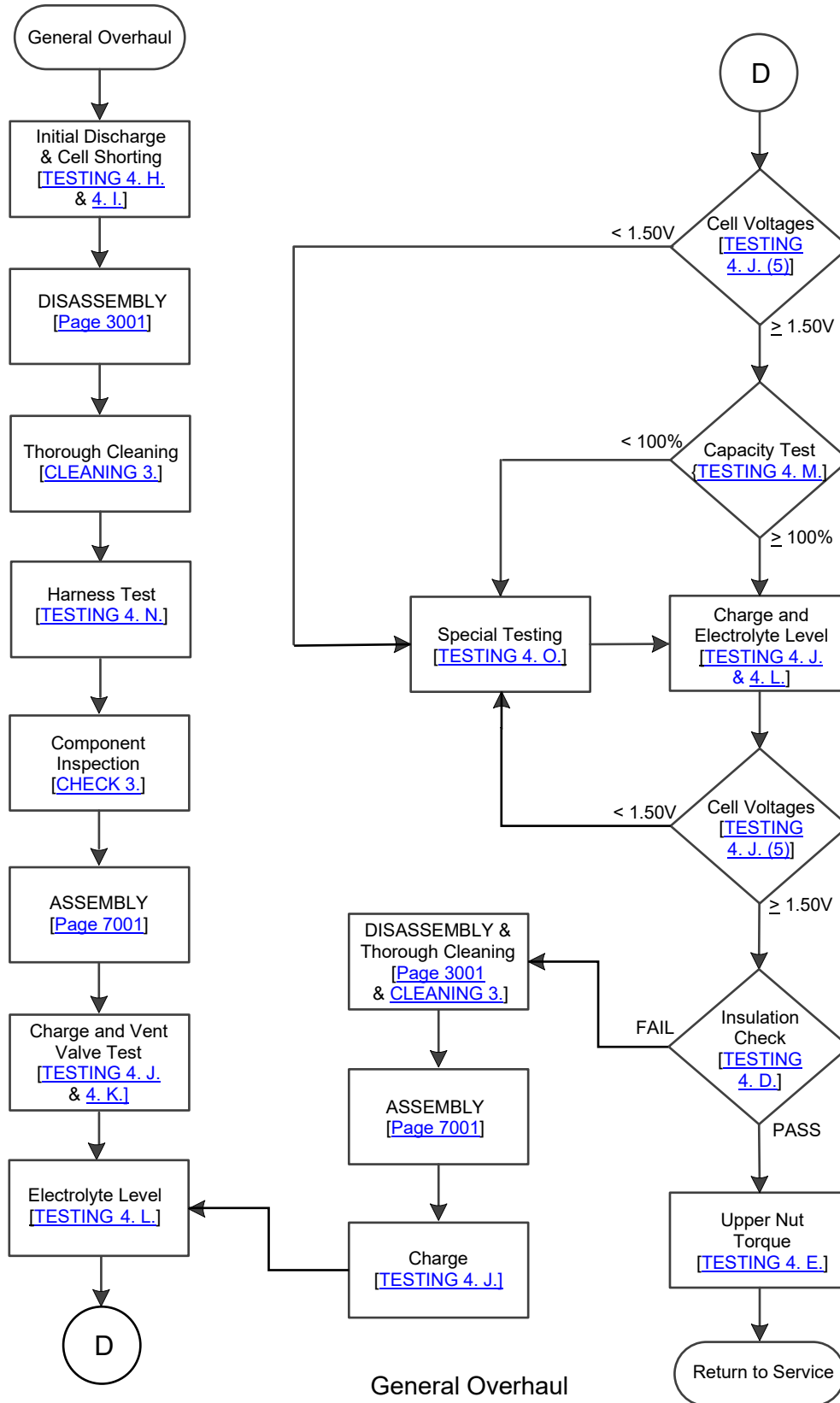

General Overhaul  
Figure 1003



COMPONENT MAINTENANCE MANUAL  
40176-4 / 40176-7

4. Testing

A. Test conditions

(1) Facilities and equipment

**CAUTION:** FUMES FROM LEAD ACID BATTERIES OR SMALL TRACES OF SULFURIC ACID ENTERING A NI-CD BATTERY CAN CAUSE PERMANENT DAMAGE.

(a) Service facilities for Ni-Cd batteries must be entirely separate from those for lead acid batteries.

(b) Equipment used to service lead acid batteries must not be used to maintain Ni-Cd batteries.

(2) For optimum results conduct all tests with the battery temperature at ambient temperature, unless otherwise noted in this manual.

B. Test equipment

Refer to [Special Tools, Fixtures, and Equipment, and Consumables](#) for test equipment recommendations.

C. Visual inspection

Items found may require doing a general overhaul immediately while the majority do not. If a finding does not require going to the general overhaul procedure, then specific instructions are provided on how and when the item will be corrected.

(1) Visually inspect battery cover ([020](#)) for dents, distortion, or other damage and replace, as necessary.

(2) Visually inspect battery case ([010](#) or [010A](#)) for dents, distortion, or other damage. Do [General overhaul](#) to replace any defective components.

(3) Visually inspect holddown pad ([030](#)) for distortion and other damage, replace as needed.

(4) Remove battery cover ([020](#)) and holddown pad ([030](#)) visually inspect each cell ([120](#)) for any evidence of electrolyte leakage.

(a) Damaged cells ([120](#)) should be identified for replacement or further cleaning.

**NOTE:** Excessive electrolyte leakage will cause the battery to fail the Battery insulation test.

(b) Excessive salts around the terminal posts gives an indication of possible leakage from terminal O-ring ([190](#)). Identify any cells with excessive salts for later torquing the lower nut ([140](#)).

(c) When inspection reveals electrolyte leakage from the cell at the vent hole opening, replace the defective O-ring ([210](#)) by referring to [Vent valve O-ring replacement](#).

(5) Inspect the nuts ([100](#)), ([130](#)), ([140](#)), washers ([110](#)), ([134](#)), ([170](#)), and ([180](#)), and links ([220](#)), ([230](#)), ([240](#)), ([250](#)), ([260](#) or [270](#)) to ensure it is free of bends, tarnish, corrosion, burns, or loss of plating. Minor tarnish can be polished off with a fine wire brush. Identify any defective components for later replacement.

**24-32-03**

1005  
Aug 4/21



COMPONENT MAINTENANCE MANUAL  
40176-4 / 40176-7

- (6) Check all ventilation openings to make sure that they are clean and clear.
- (7) Inspect the power connector ([280](#)) and its pins for defects, evidence of arcing or excessive oxidation. If observed, identify the power connector ([280](#)) for later replacement.

D. Battery insulation

**NOTE:** A breakdown in electrical insulation between the cells and the battery case will result in a "leakage" current, which, over a period of time, can discharge the battery.

- (1) On a completely assembled battery, measure the insulation resistance between the block of cells and the metal case. The value measured must be at least 10M $\Omega$  under a 250V continuous using a megohmmeter.

- (a) If the reading does not meet the above criteria, record the value and the insulation shall be considered a "FAIL".

**NOTE:** If, after cleaning the battery and assuring that everything is dry, the insulation resistance is still less than 10M $\Omega$ , then one or more cells ([120](#)) are defective. Isolate and identify for replacement or cleaning.

- (b) If the reading meets the above criteria ( $\geq 10\text{M}\Omega$ ), record the value and the insulation test is a "PASS".

E. Upper nut torque

Check the torque on each upper nut ([100](#)), ([130](#)) per [Table 8001](#).

F. Cell voltage

Measure and verify the voltage of each cell ([120](#)) is greater than or equal to 1.05V.

G. Polarization test

- (1) Charge the battery at 0.1C<sub>1</sub> for 1.5 hours.
- (2) Keep the battery in open circuit for 1 hour.
- (3) Measure the open circuit voltage of each cell ([120](#)).
  - (a) Identify for replacement each cell ([120](#)) with zero volts or negative polarity. If any cell ([120](#)) is identified for replacement, the polarization test is a "FAIL".
  - (b) If all cells ([120](#)) are above zero volts, the polarization test is a "PASS".

H. Initial discharge (off-wing capacity)

The purpose of this procedure is to discharge the battery to a known state of charge and determine the battery capacity from the aircraft.

- (1) Discharge the battery at a rate shown in [Table 1001](#) until the battery reaches 20.0V. Record the times the first cell reaches 1.0V and battery reaches 20.0V.

**NOTE:** It is important that the discharge current be continually maintained at the selected value, and that the time of discharge be measured accurately.

**NOTE:** If a cell goes to zero volts or reverses polarity during the discharge, short out the cell's terminals for the rest of the discharge.



COMPONENT MAINTENANCE MANUAL  
40176-4 / 40176-7

**NOTE:** C<sub>1</sub>A designates the rated one-hour capacity.

DISCHARGE		MINIMUM TIME FOR FIRST CELL TO 1.0V
RATE (C <sub>1</sub> )	CURRENT (A)	
0.5	21.5	60.5 MINUTES
1.0	43.0	30.0 MINUTES

Initial Discharge (Off-Wing Capacity)  
Table 1001

- (a) The minimum discharge time to 20.0V at 1.0C<sub>1</sub>A should be 30 minutes or 0.5C<sub>1</sub>A should be 60.5 minutes. If not, one of the following may be the cause.
  1. The battery was discharged since the last aircraft charge.
  2. The aircraft charger may not be functioning properly.
  3. If the battery was left idle for a time, then self-discharge occurred.
  4. The battery cells may be imbalanced and need servicing.
- (2) If defective items were found during visual inspection, they are to be corrected.
  - (a) For each cell ([120](#)) identified for replacement, do [Cell replacement](#).
  - (b) Replace as needed power connector ([280](#)), do [Power connector replacement](#).
  - (c) Remove and replace as needed nuts ([100](#)), ([130](#)) and washers ([110](#)), ([134](#)). Torque nuts per [Table 8001](#).
  - (d) Replace as needed links ([220](#)), ([230](#)), ([240](#)), ([250](#)), ([260](#) or [270](#)) using [Link replacement](#).
  - (e) For each cell ([120](#)) which have excessive salts around the terminals during visual inspection, do [Lower nut torque](#).
  - (f) For cell hardware ([140](#)), ([150](#)), ([160](#)), ([170](#)), ([180](#)), and O-ring ([190](#)) requiring replacement, do [Cell hardware replacement](#).
- I. Cell shorting
  - (1) Confirm the vent valves ([200](#)) are finger tight on each cell ([120](#)) by using [T01](#). Do not over-tighten.
  - (2) Discharge each cell to zero volts using one of two methods below:

**NOTE:** It is not necessary to have a rest period between discharge and cell shorting.

    - (a) Method A
      1. Continue to discharge per [Table 1001](#) until each cell is < 1.0V, connect a [T03](#) across its terminals. After all the cells have been shorted, then leave the devices in place for 12 to 24 hours.
    - (b) Method B
      1. Continue to discharge the battery per [Table 1001](#) until each cell is < 0.5V, then connect a shorting clip between its terminals. After all the cells have been shorted, then leave these clips on for 16 to 24 hours.
  - (3) At completion of Method A or B, remove the shorting devices.
  - (4) If no cell ([120](#)) is identified for replacement, return to [Figure 1002](#) or [Figure 1003](#).





COMPONENT MAINTENANCE MANUAL  
40176-4 / 40176-7

(5) If any cell ([120](#)) was identified for replacement, do [Cell replacement](#).

J. Charge

- (1) Allow the battery to cool to ambient temperature.
- (2) Remove the cover ([020](#)) and holddown pad ([030](#)).
- (3) Prior to charging the battery, loosen (do not remove) all vent valves ([200](#)). Ensure that the shorting spring has been removed.

**NOTE:** If the vent valve test is to be done per [Figure 1003](#), do [Vent valve test](#) during the charge.

- (4) Charge the battery using one of the three methods in [Table 1002](#).
  - (a) Record the cell voltages at the start and end of the main charge (Step 1), and then the last 30 minutes of the final charge (Step 2)
    1. If the start cell voltage of the main charge (Step 1) goes above 1.50V, add to the cell about 10 cm<sup>3</sup> (0.61 in<sup>3</sup>) of [M01](#).
    2. During the last 30 minutes of the final charge (Step 2), adjust the [Electrolyte level](#) and check for [Minimum final charge voltage](#).

**NOTE:** C<sub>1</sub>A designates the rated one-hour capacity.

CHARGE TABLE				
MAIN CHARGE (STEP 1)			FINAL CHARGE (STEP 2) *	
Current	Minimum Time	End of Main Charge Criteria	Current	Time
0.1C <sub>1</sub> A	10h	Every cell >1.5V or 12h whichever comes first	0.1C <sub>1</sub> A	4h
0.5C <sub>1</sub> A	2h	Every cell >1.55V or 2.5h whichever comes first	0.1C <sub>1</sub> A	4h
1.0C <sub>1</sub> A	1h	Every cell >1.57V or 1.25h whichever comes first	0.1C <sub>1</sub> A	4h

\* During the last 30 minutes do [Electrolyte level](#) and confirm minimum voltage criteria in [Table 1003](#).

Charge Table  
Table 1002

(5) Minimum final charge voltage

During the last 30 minutes of final charge (Step 2) measure and verify the voltage of each cell ([120](#)) meets the value shown in [Table 1003](#). Identify each cell that does not comply.

CELL VOLTAGE (Last 30 minutes at 0.1C <sub>1</sub> A)
≥ 1.50V

Final Charge Voltage Limit  
Table 1003



COMPONENT MAINTENANCE MANUAL  
40176-4 / 40176-7

K. Vent valve test

**CAUTION:** THE CELL OPENINGS MUST BE COVERED WITH A CLEAN DAMP CLOTH TO PREVENT ENTRY OF FOREIGN MATTER.

**NOTE:** This test is not necessary if all the vent valves are replaced with Saft new valves each year or applicable maintenance interval.

**NOTE:** It is recommended to do this test while the battery is on charge.

- (1) Check the operation of the vent valve ([200](#)) assemblies as follows:
  - (a) Use [T05](#) fixture and affix the vent valve ([200](#)) that contains O-ring ([210](#)) into the adapter end of the test fixture.
  - (b) Attach the [T05](#) fixture to a compressed air line through an adjustable pressure reducing valve limited to 1.38 bar (20 psi).
  - (c) Slowly raise the air pressure to 1.38 bar (20 psi) maximum to functionally test below.
  - (d) Immerse the valve and end of fixture in water, and slowly raise the pressure. Make sure the valve opens between 0.14 bar to 0.69 bar (2 psi to 10 psi).
  - (e) Reuse only those vent valves found to open in the 0.14 to 0.69 bar (2 psi to 10 psi) range. Re-soak vent valves that do not open at 0.69 bar (10 psi) until they do open (refer to [CLEANING](#) on page [4001](#)). Discard vent relief valves which are not gas tight at low pressure.

L. Electrolyte level

This procedure is to be carried out only during the last 30 minutes of the 0.1C<sub>1</sub>A final charge (Step 2).

**WARNING:** USE CARE NOT TO TILT CELLS WHILE VENT VALVES ARE LOOSENED OR REMOVED; CONTACT OF ELECTROLYTE WITH SKIN CAN CAUSE SEVERE BURNS.

**CAUTION:** USING ANYTHING OTHER THAN [M01](#) IN NICKEL-CADMIUM CELLS WILL CAUSE ELECTROLYTE CONTAMINATION AND DAMAGE. DO NOT RE-USE WATER REMOVED FROM CELLS.

- (1) Remove the vent valves ([200](#)) with the [T01](#), taking precautions to prevent entry of foreign matter into the cell ([120](#)).
  - (a) Clean vent valves ([200](#)) by immersing the valves and their O-rings ([210](#)) in [M01](#) and let them soak to dissolve any salts.
- (2) Inserting [T02](#) into the cell opening until the shoulder of the nozzle rests on the valve seat as shown in [Figure 1004](#).

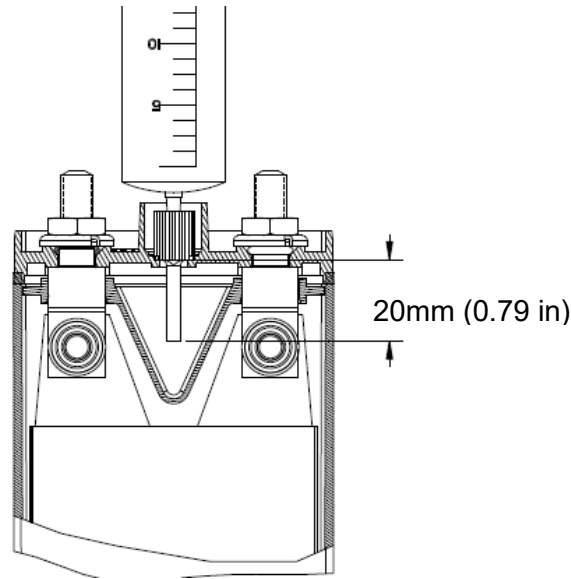

Position of Syringe in Cell Vent Seat  
Figure 1004

- (3) Withdraw the plunger and check for any liquid in the [T02](#).
  - (a) Any excess liquid in the cell will be drawn into the syringe until the electrolyte level is correct.
  - (b) If the liquid level is too low, the syringe will remain empty, indicating that the end of the syringe nozzle did not reach the liquid in the cell.

**NOTE:** If the quantity of water added per cell exceeds  $25 \text{ cm}^3$  ( $1.53 \text{ in}^3$ ), then check the charging system. If the charger is functioning properly, the maintenance period may need to be reduced.

1. Draw a measured amount of [M01](#), such as  $5 \text{ cm}^3$  ( $0.31 \text{ in}^3$ ) into [T02](#) and inject it into the cell.
2. With the syringe nozzle resting on the valve seat, slowly withdraw the plunger into [T02](#).
3. If [T02](#) remains empty, repeat steps 1 and 2, counting the number of  $\text{cm}^3$  injections required to achieve the correct level.
4. At the point in step 2 when some excess liquid is drawn into the syringe, the correct level for that cell has been reached. Expel the excess liquid into a separate container for proper disposal of hazardous waste.
5. Record the amount of water added/removed from each cell in the battery logbook or battery test sheet.

M. Capacity test (second discharge)

The purpose of this discharge procedure is to verify minimum battery capacity.

- (1) Prior to doing the capacity test, do [Charge](#) and [Electrolyte level](#).
- (2) The vent valve ([200](#)) must be installed with [T01](#) finger tight on top of each cell ([120](#)). Do not over-tighten.

## COMPONENT MAINTENANCE MANUAL

40176-4 / 40176-7

- (3) Discharge the battery at one of the current rates shown in [Table 1004](#) until the battery reaches 20.0V to determine and record the times the first cell reaches 1.0V and battery reaches 20.0V.

**NOTE:** It is important that the discharge current be continually maintained at the selected value, and that the time of discharge is measured accurately.

**NOTE:** If a cell goes to zero volts or reverses polarity during the discharge, short out that cell's terminals with [T03](#) for the remainder of the discharge.

DISCHARGE		MINIMUM TIME FOR FIRST CELL TO 1.0V
RATE (C <sub>1</sub> )	CURRENT (A)	
0.5	21.5	122.0 MINUTES
1.0	43.0	60.0 MINUTES

Capacity Test (Second Discharge)  
Table 1004

- (4) If the time until the first cell reached 1.0V equals or exceeds the values shown in [Table 1004](#) at the discharge rate, then the capacity is  $\geq 100\%$ . Allow the battery to rest at least 2 hours.
- (5) If the time the first cell reached is less than the minimum time shown in [Table 1004](#) at the discharge rate, the capacity is  $< 100\%$ .

N. Sensor harness ([040](#) or [050](#)) test

**WARNING:** A FULLY ASSEMBLED BATTERY MUST BE IN A FULLY DISCHARGED CHARGE STATE TO PREVENT INJURY, REFER TO [CELL SHORTING](#).

- (1) If any part of the harness ([040](#) or [050](#)) is damaged, the entire assembly must be replaced with new Saft sensor harness ([040](#) or [050](#)).

**NOTE:** A climate chamber or alternate methods may be used provided the temperatures below are achieved.

**NOTE:** Refer to [Figure 1005](#) for pinout locations.

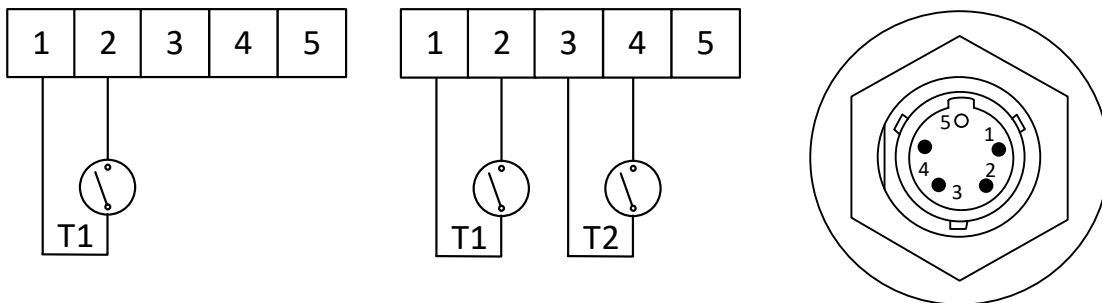

P/N 015949-000 ([040](#))

P/N 016420-000 ([050](#))

Pinout  
Figure 1005



COMPONENT MAINTENANCE MANUAL  
40176-4 / 40176-7

(2) Sensor harness ([040](#) or [050](#))

Verify the sensor values at the temperature as required by [Table 1005](#). Any erratic readings represent a failure and replace with new Saft sensor harness ([040](#) or [050](#)).

SENSOR P/N	IPL	BATTERY TYPE	PINS	VALUES
015949-000	<a href="#">040</a>	40176-4	pins 1 to 2	Closes < 5Ω on rise @57 ± 2.8°C (135 ± 5°F) Opens > 1 MΩ maximum differential of @ -6.2°C (12°F) Max
016420-000	<a href="#">050</a>	40176-7	pins 1 to 2	Normally Open > 1 MΩ Closes on rise 57 ± 2.8°C (135 ± 5°F)
			pins 3 to 4	Closed < 5Ω @ 1.8 ± 2.8°C (35 ± 5°F) Opens > 1 MΩ @ 10°C (50°F) Max

Sensor Values  
Table 1005

O. Special testing

These procedures are to be followed for a battery that does not meet capacity or if the end of charge cell voltage was less than 1.50V during the final charge. Refer to [Figure 1006](#) flow chart.

**NOTE:** For a new battery or one removed from the aircraft that has not passed capacity after doing the special testing more than 3 times, then it is recommended to replace noncompliant cells with new Saft cells ([120](#)), refer to [All cell replacement](#) recommendation.

**NOTE:** For battery from long-term storage, several complete charge/discharge cycles may be needed to restore performance.

(1) Special testing decision

For a battery with < 100% capacity, start at [Low capacity \(Special testing\)](#) below. Otherwise for a battery with cell(s) voltage(s) less than 1.50V start at [Supplementary test](#) below.

(2) Low capacity (Special testing)

(a) Loosen, but do not remove, all vent valves ([200](#)) and fully charge the battery as outlined in [Charge](#) section.

(b) For a battery containing cell(s) with voltages less than 1.50V during the final charge, then do [Supplementary test](#) below. Otherwise do [Capacity test \(Special testing\)](#) below.



COMPONENT MAINTENANCE MANUAL  
40176-4 / 40176-7

(3) Supplementary test

- (a) Charge at 0.1C<sub>1</sub>A for an additional 5 hours and monitor the voltage of the individual cells every 30 minutes.
1. Identify any cell ([120](#)) that does not comply with [Table 1003](#) for replacement.
  2. During the last 30 minutes of this charge adjust the [Electrolyte level](#), and then finger tighten the vent valves ([200](#)) on top of each cell ([120](#)) with [T01](#). Do not over-tighten
  3. Do [Cell replacement](#) for cells identified for replacement otherwise go to [Capacity test \(Special testing\)](#).

**NOTE:** If more than one cell ([120](#)) was replaced due to low charge voltage during the current maintenance cycle, then the replacement of all cells should be considered. (See [Cell replacement](#) on page [6001](#)).

(4) Capacity test (Special testing)

- (a) Finger tighten (do not over-tighten) with [T01](#) the vent valve ([200](#)) on top of each cell ([120](#)), then discharge the battery at a rate shown in [Table 1004](#) until the battery reaches 20.0V. Record the time and current the battery reached 20.0V and identify noncompliant cells with voltages less than 1.0V.
- (b) If the time the first cell reached 1.0V equals or exceeds the values shown in [Table 1004](#) at the applicable discharge rate, then return to [Figure 1001](#), [Figure 1002](#), or [Figure 1003](#). Otherwise repeat [Low capacity \(Special testing\)](#) or refer to [Fault Isolation](#).
1. For noncompliant cells that have failed this capacity test 3 times, replace with new Saft cells ([120](#)), refer to [Cell replacement](#).

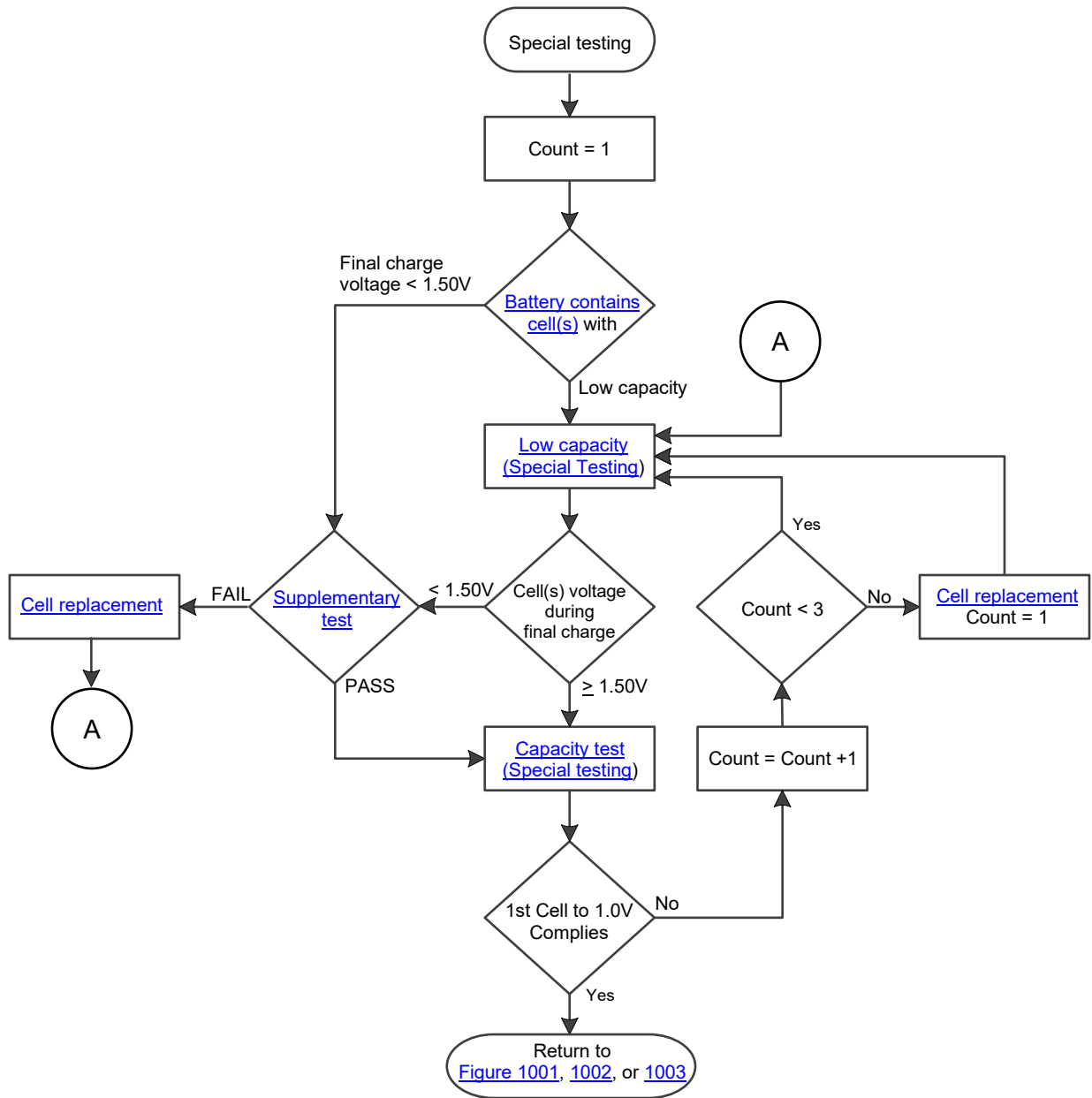

Special Testing Flow Chart  
Figure 1006



COMPONENT MAINTENANCE MANUAL  
40176-4 / 40176-7

5. Fault Isolation

Fault isolation information is presented in [Table 1006](#), [Table 1007](#), and [Table 1008](#) as a guide in locating a cause of malfunction and isolating the cause to a specific component.

TROUBLE	PROBABLE CAUSE	REMEDY
(1) Zero battery voltage	(a) Defective electrical connector (not making contact).  (b) Broken or damaged links	Check electrical connections, replace if required <a href="#">Power connector replacement</a> , <a href="#">Cell hardware replacement</a> , <a href="#">Link replacement</a> , or <a href="#">Upper nut torque</a>
(2) Low insulation	(a) Leakage of electrolyte (b) Incorrect adjustment of electrolyte level (c) Reverse cell polarity (d) Condensation / Contamination (e) Improper cleaning	Do <a href="#">Thorough Cleaning</a> , <a href="#">ASSEMBLY</a> , <a href="#">Charge</a> , <a href="#">Electrolyte level</a>
	(f) Loose or damage vent valve	Finger tighten or replace vent valve, do <a href="#">Thorough Cleaning</a> , <a href="#">ASSEMBLY</a> , <a href="#">Charge</a> , <a href="#">Electrolyte level</a>
	(g) Damaged cell case	Do <a href="#">Thorough Cleaning</a> , <a href="#">Cell replacement</a> , <a href="#">ASSEMBLY</a> , <a href="#">Charge</a> , <a href="#">Electrolyte level</a>
	(h) Charge rate too high	Investigate the cause of the excessive charge. Do <a href="#">Thorough Cleaning</a> , <a href="#">ASSEMBLY</a> , <a href="#">Charge</a> , <a href="#">Electrolyte level</a>
(3) Loss of battery capacity	(a) Normal wear after long service  (b) Exceptionally heavy usage (high cycling on AC, high temperature, etc.)	Do <a href="#">Special testing</a>

Battery Faults  
Table 1006





COMPONENT MAINTENANCE MANUAL  
40176-4 / 40176-7

TROUBLE	PROBABLE CAUSE	REMEDY
(1) All cells have reserve consumed	(a) Charged more than allowed or charged at high temperature. (b) Previous maintenance has not been done (c) Maintenance interval too long	Examine the cause of the excessive charge. Do <a href="#">Charge</a> , <a href="#">Electrolyte level</a> and be sure what for the next maintenance interval.  If this continues a periodical check should be done in between the regular checks.
(2) High water consumption in one or more cells	(a) Damaged separator when the water consumption is less than 30% below the average value of added water in all cells. (b) Cell imbalance when water addition is more than 30% above the average value of added water in all cells.	Do <a href="#">Charge</a> , <a href="#">Supplementary test</a> .  Do <a href="#">Thorough Cleaning</a> , <a href="#">Cell replacement</a> , <a href="#">ASSEMBLY</a> , <a href="#">Charge</a> , <a href="#">Electrolyte level</a>
(3) Abnormally high cell voltage at beginning of charge	(a) Dry cell	Add 5 to 10 cm <sup>3</sup> (0.31 to 0.61 in <sup>3</sup> ) of distilled water, do <a href="#">Electrolyte level</a> during final charge
(4) Zero Voltage on cell	(a) Short circuited cell	Do <a href="#">Cell replacement</a>
(5) Low cell voltage at end of charge	(a) Separator damage	Do <a href="#">Cell replacement</a>
(6) Low cell capacity	(a) Normal wear from long service	Do <a href="#">Cell replacement</a>
(7) Cell with a swollen case	(a) Cell operated with low electrolyte level, deterioration of separator and damaged plates	Do <a href="#">Cell replacement</a>

Cell Faults  
Table 1007



COMPONENT MAINTENANCE MANUAL  
40176-4 / 40176-7

TROUBLE	PROBABLE CAUSE	REMEDY
(1) Tarnished or burned terminal connectors	(a) Loose terminal nuts and links	Clean and torque per <a href="#">Table 8001</a> or do <a href="#">Power connector replacement</a> , <a href="#">Link replacement</a> , or <a href="#">Cell hardware replacement</a> .
(2) Exposed copper material on power connector pin	(a) Mechanical damage (b) Electrical arcing	Do <a href="#">Power connector replacement</a>
(3) Melted plastic on connectors	(a) Overheat due to contact resistance	Do <a href="#">Power connector replacement</a>
(4) Corroded links	(a) Operation in acidic atmosphere (b) Inadequate greasing (c) Mechanical damage to protective nickel-plating	Check room, eliminate acid source Do <a href="#">Link replacement</a> and lubricate properly  Do <a href="#">Link replacement</a> and lubricate properly

Physical Faults  
Table 1008



COMPONENT MAINTENANCE MANUAL  
40176-4 / 40176-7

PAGE INTENTIONALLY LEFT BLANK

**24-32-03**

Blank  
Aug 4/21



COMPONENT MAINTENANCE MANUAL  
40176-4 / 40176-7  
**DISASSEMBLY**

1. General

This section provides step-by-step instructions on disassembling the complete battery.

**NOTE:** The ( ) part identification numbers herein are IPL [Figure 1](#) item numbers.

2. Detailed Instructions

**WARNING:** BATTERY CELL ASSEMBLIES DELIVER VERY HIGH CURRENTS WHEN SHORT-CIRCUITED. EXERCISE CAUTION. REMOVE RINGS, WATCHES OR OTHER JEWELRY FROM HANDS AND ARMS.

**WARNING:** BATTERY MUST BE COMPLETELY DISCHARGED BEFORE CELL ASSEMBLIES CAN BE REMOVED DUE TO POSSIBILITY OF ELECTRIC SHOCK.

**WARNING:** USE CARE NOT TO TILT BATTERY WHILE VENT VALVES ARE LOOSENEED; CONTACT OF ELECTROLYTE WITH SKIN CAN CAUSE SEVERE BURNS.

A. Preparation

- (1) Discharge the battery at one of the current rates shown in [Table 1004](#) until each cell reaches 1.0V.
- (2) Remove cover ([020](#)) by opening latches and lifting cover from case ([010](#) or [010A](#)).
- (3) Do [Cell shorting](#)

B. Cell ([120](#)) removal

- (1) Remove the upper nuts ([100](#)), ([130](#)) and washers ([110](#)), ([134](#)) from the battery.
- (2) Remove intercell terminal links ([220](#)), ([230](#)), ([240](#)), ([250](#)), ([260](#) or [270](#)) from terminals of cells ([120](#)).
- (3) Using [T04](#) tighten on the cell terminals as needed to remove cells ([120](#)) from the battery case ([010](#) or [010A](#)).

C. Disassembly of the cell assemblies ([120](#)) is restricted to replacing defective O-rings ([190](#)) of the cell terminal seals and small cell hardware, refer to [Cell hardware replacement](#).

D. Power connector ([280](#))

Remove power connector ([280](#)) and gasket ([300](#)) by removing four screws ([290](#)).

E. Sensor harness ([040](#) or [050](#)) removal

- (1) Remove the connector nut ([080](#)) and O-ring ([090](#)) of the sensor assembly from the battery case ([010](#) or [010A](#)).
- (2) For sensor harness ([040](#)) separate the thermostat from link ([250](#)) by removing the hex nut ([060](#)).
- (3) For sensor harness ([050](#)) separate the thermostats from links ([250](#)), ([270](#)) by removing the hex nuts ([070](#)).

F. Remove all spacers ([310](#)) from the battery case ([010](#) or [010A](#)).

**24-32-03**

3001  
Aug 4/21



COMPONENT MAINTENANCE MANUAL  
40176-4 / 40176-7

PAGE INTENTIONALLY LEFT BLANK

**24-32-03**

Blank  
Aug 4/21



COMPONENT MAINTENANCE MANUAL  
40176-4 / 40176-7

**CLEANING**

1. General

**CAUTION:** DO NOT USE PETROLEUM SPIRITS, TRICHLOROETHYLENE, OR OTHER SOLVENTS FOR CLEANING THE BATTERY. USE OF THESE PRODUCTS MAY DETERIORATE THE INTEGRITY OF METAL PARTS.

**NOTE:** The ( ) part identification numbers herein are IPL [Figure 1](#) item numbers.

- A. The following items are required to do the cleaning procedures (equivalent substitutes can be used):
- (1) Stiff bristled brush (nonmetallic)
  - (2) Dry compressed air source, less than 1.38 bar (20 psi)
  - (3) Safety goggles
  - (4) Lubricant, non-acid petroleum jelly, [M02](#)
  - (5) Soft, clean cloth (two required)
  - (6) Running water
  - (7) Mild soap, [M03](#)
  - (8) Distilled or de-ionized water, [M01](#)

2. Light Cleaning

- A. The following procedures are for an assembled battery with battery cover ([020](#)) and holddown pad ([030](#)) removed.
- B. Using vent valve wrench [T01](#), make sure that the vent valves ([200](#)) of all cells ([120](#)) are finger tight, closed and secure. Do not over-tighten.
- C. Remove white deposits (potassium carbonate) from tops of all cells ([120](#)) using a stiff bristled nonmetallic brush.

**WARNING:** TO PREVENT INJURY WHEN USING COMPRESSED AIR, DIRECT STREAM AWAY FROM BODY. USE SAFETY GOGGLES TO PREVENT EYE INJURIES FROM FINE DUST PARTICLES.

- D. Disperse residual dust and particles from the battery with blasts of clean, dry, compressed air not over 1.38 bar (20 psi).
- E. Coat hex nuts ([100](#)), ([130](#)), ([140](#)), washers ([110](#)), ([134](#)) ([170](#)), ([180](#)), and all intercell terminal links ([220](#)), ([230](#)), ([240](#)), ([250](#)), ([260](#) or [270](#)) with [M02](#).

**CAUTION:** SILICONE COATINGS ARE NOT SUITABLE DUE TO THE ALKALINE ELECTROLYTE.

- F. Clean the exterior surfaces of the battery cover ([020](#)) and battery case ([010](#) or [010A](#)) using a soft, clean cloth, moistened with water. Dry with compressed air not over 1.38 bar (20 psi) or a dry, clean cloth.

**24-32-03**

4001  
Aug 4/21



COMPONENT MAINTENANCE MANUAL  
40176-4 / 40176-7

3. Thorough Cleaning

- A. The battery must be discharged (refer to [Initial Discharge](#) and [Cell shorting](#)) and disassembled (refer [DISASSEMBLY](#)).
- B. Remove greasy residue from power connector ([280](#)) with warm mild soapy [M03](#) water.
- C. After ensuring that the vent valves ([200](#)) are closed, wash each cell ([120](#)) in running water. Do not allow any water to enter the cell. Dry with compressed air not over 1.38 bar (20 psi) or a dry, clean cloth.
- D. Remove dirt and salt deposits from the battery case ([010](#) or [010A](#)), cover ([020](#)), pad ([030](#)), spacers ([310](#)), links ([220](#)), ([230](#)), ([240](#)), ([250](#)), ([260](#) or [270](#)), washers ([110](#)), ([134](#)), nuts ([060](#) or [070](#)), ([080](#)), ([100](#)), ([130](#)), screws ([290](#)), O-ring ([090](#)), and gasket ([300](#)) in warm mild soapy [M03](#) water. A plastic scraper or a stiff bristled brush (nonmetallic) may be used to aid in the removal of heavy deposits. Rinse away all [M03](#) and dry with compressed air not over 1.38 bar (20 psi) or a dry, clean cloth.



COMPONENT MAINTENANCE MANUAL  
40176-4 / 40176-7

**CHECK**

1. General

This section contains new battery commissioning and component inspection information.

**NOTE:** All voltage readings are DC unless specifically otherwise stated.

**NOTE:** All ( ) part identification numbers herein are IPL [Figure 1](#) item numbers.

2. Initial New Battery Commissioning

A. Before the initial charge, thoroughly inspect the battery assembly to ensure no damage has occurred during shipping or storage as follows:

**NOTE:** For a new battery not receiving its initial commission within one year of its DOM, then battery must follow [Figure 1002](#)

- (1) Inspect the battery case ([010](#) or [010A](#)) and cover ([020](#)) for dents, distortion, or other damage. Refer to [Case and cover minor repairs](#).
- (2) Remove the battery cover ([020](#)) and pad ([030](#)).
- (3) Visually confirm the power connector ([280](#)) is present and undamaged.
- (4) Visually confirm all cells ([120](#)) are positioned for proper polarity per [Figure 7002](#).
- (5) Visually confirm all cells ([120](#)) are equipped with a vent valve ([200](#)).
- (6) Torque all upper nuts ([100](#)), ([130](#)) per [Table 8001](#).
- (7) Visually confirm the sensor harness ([040](#) or [050](#)) is present and undamaged.

B. [Charge](#) the battery as shown on page [1008](#) and level electrolyte per [Electrolyte level](#) on page [1009](#).

C. Do successful [Battery insulation](#) test and install battery pad ([030](#)) and cover ([020](#)), then the battery is ready for service.

3. Component Inspection

A. Cell ([120](#)).

- (1) Visually check each cell carefully for evidence of electrolyte leakage, cracks, corrosion, burns, holes, or cross-threaded terminals. Replace all damaged cells with new Saft cells ([120](#)).
- (2) Excessive salt around a terminal post indicates leakage. Refer to [Cell hardware replacement](#) on page [6002](#) for replacement of lower terminal O-ring ([190](#)) if leakage is evident.
- (3) Visually check each cell vent valve ([200](#)) for defective O-rings ([210](#)), cracks, or other physical damage. Replace if defective.
- (4) Suspect vent valves should be tested in accordance with [Vent valve test](#) and/or be discarded.

B. Intercell terminal links ([220](#)), ([230](#)), ([240](#)), ([250](#)), ([260](#) or [270](#))

Inspect for bends, tarnish, loss of nickel plating, corrosion, or burns. Tarnish can be polished off with a fine wire brush. Replace any defective intercell links.

**24-32-03**

5001  
Aug 4/21





COMPONENT MAINTENANCE MANUAL  
40176-4 / 40176-7

C. Spacers ([310](#)) and pad ([030](#))

The components should be clean and free of cracks or defects. Replace any that are defective with new Saft components.

D. Power connector ([280](#))

**CAUTION:** A DEFECTIVE POWER CONNECTOR ([280](#)) CAN CAUSE DANGEROUS OVERHEATING, AS WELL AS IN SERVICE LOW VOLTAGE.

- (1) Inspect the power connector ([280](#)) for evidence of arcing, corrosion, cracks, or cross threaded terminals.
- (2) Using the method in [Battery insulation](#) check on page [1006](#), check the insulation between the positive pin and the connector shell and the negative pin and connector shell.
- (3) Discard any power connector ([280](#)) that is found to have any damage or fails the insulation test. Replace with new Saft power connector ([280](#)).

E. Sensor harness ([040](#) or [050](#))

- (1) Inspect electrical connector for bent or loose pins, corrosion, cracks, faulty wire connections, and evidence of arcing.
- (2) Inspect thermostat(s) for damage, loose or broken wire connections, cracks, dents, or other physical defects.
- (3) Visually check all wiring damage to insulation, cracked or broken wire, and other physical defects.
- (4) Any evidence of the above conditions, however minor, is grounds for rejection. Discard the damaged unit and replace with new Saft sensor harness ([040](#) or [050](#)).

**NOTE:** Sensor harness ([040](#) or [050](#)) is a non-repairable item and should be discarded if defective.

F. Battery cover ([020](#)) and case ([010](#) or [010A](#))

Inspect the components for minor damage. If found, do [Battery cover and case minor dents](#). Otherwise replace with new Saft components, cover ([020](#)) and case ([010](#) or [010A](#)).



COMPONENT MAINTENANCE MANUAL  
40176-4 / 40176-7

**REPAIR**

1. General

This section contains basic battery component for removing and replacing components.

**NOTE:** The ( ) part identification numbers herein are IPL [Figure 1](#) item numbers.

**NOTE:** All voltage readings are DC unless specifically otherwise stated.

2. Required Test Equipment

**NOTE:** Test equipment having equivalent specifications can be used.

Refer to [Special Tools, Fixtures, Equipment, and Consumables](#) for listing of Standard Tools.

3. Component Replacement

A. Cell ([120](#)) replacement

Battery containing cell(s) require replacement. Note the [All cell replacement](#) recommendation below.

(1) All cell replacement

- (a) For a battery compliant with the following then it is best to assume that all the original cells are or soon will be in unsatisfactory condition. Saft strongly recommends all cells ([120](#)) should be replaced with new Saft cells for a battery having:

1. 3 or more cells are replaced during the same maintenance interval.

Or

2. 1 or more cells are found to be faulty due to low capacity during this maintenance period and 5 of the original cells in the battery had been previously replaced due to low capacity.

**NOTE:** The recommendation does not apply to the following failures:  
terminal thread damage, cell leakage, or cell short-circuit

(2) Procedure

- (a) Discharge the battery completely by doing a [Cell shorting](#).
- (b) Remove upper hex nuts ([100](#)), ([130](#)), washers ([110](#)) ([134](#)), and intercell connecting links ([220](#)), ([230](#)), ([240](#)), ([250](#)), ([260](#) or [270](#)) as required to remove the defective cell ([120](#)).
- (c) Attach [T04](#) to the terminal of the cell and remove cell ([120](#)) from the case using a steady upward pull.
- (d) Insert a new Saft cell ([120](#)) into the case and pushing it downward on the cell terminals with a small block of soft wood, if necessary (refer [All cell replacement](#))

**NOTE:** New cell must be discharged before installation is done.

- (e) Attach intercell connecting links ([220](#)), ([230](#)), ([240](#)), ([250](#)), ([260](#) or [270](#)), washers ([110](#)), ([134](#)), and upper hex nuts ([100](#)), ([130](#)) as required, and torque nuts per [Table 8001](#).

**24-32-03**

6001  
Aug 4/21



COMPONENT MAINTENANCE MANUAL  
40176-4 / 40176-7

B. Lower nut (140) torque

- (1) Remove applicable hardware; nuts (100), (130), washers (110) (134) and links (220), (230), (240), (250), (260 or 270). Torque the lower nut (140) per [Table 8001](#).
- (2) Install the applicable hardware; the links (220), (230), (240), (250), (260 or 270), washers (110) (134), and nuts (100), (130). Torque the nuts per [Table 8001](#).

C. Cell hardware (140), (150), (160), (170), (180), and O-ring (190) replacement

**WARNING:** USE CARE NOT TO TILT CELLS WHILE LOWER HARDWARE ARE LOOSENED OR REMOVED; CONTACT OF ELECTROLYTE WITH CAN CAUSE SEVERE BURNS.

**NOTE:** The battery should be discharged prior to starting cell hardware replacement.

- (1) Replace necessary cell hardware (140), (150), (160), (170), (180) by removing and replacing the nuts (100), (130), washers (110), (134), and links (220), (230), (240), (250), (260 or 270). Torque nuts per [Table 8001](#).
- (2) Terminal O-ring (190) replacement
  - (a) Remove necessary hardware; nuts (100), (130), washers (110), (134), and links (220), (230), (240), (250), (260 or 270).
  - (b) Remove lower nut (140), the polarity washer (150 or 160), the washers (170), (180), and terminal O-ring (190) being careful to prevent anything from falling into the cell opening.
  - (c) Replace O-ring (190), install washers (180), (170), the polarity washer (150 or 160), and torque lower hex nut (140) per [Table 8001](#).

**NOTE:** Spring washers (170) should be put in parallel, stacked in the same direction with the larger edge downward on the terminal.

- (d) Install the necessary links (220), (230), (240), (250), (260 or 270), washers (110) (134), and nuts (100), (130). Torque nuts per [Table 8001](#) as required.

D. Link replacement (220), (230), (240), (250), (260 or 270)

- (1) As required remove the nuts (100), (130) and washers (110), (134) from the link.
- (2) Replace the link (220), (230), (240), (250), (260 or 270) as required and then install the washers (110) (134), and nuts (100), (130). Torque nuts per [Table 8001](#).

E. Vent valve O-ring (210) replacement

**WARNING:** USE CARE NOT TO TILT CELLS WHILE VENT VALVES ARE LOOSENED OR REMOVED; CONTACT OF ELECTROLYTE WITH CAN CAUSE SEVERE BURNS.

- (1) Using the vent valve wrench [T01](#), loosen and remove the vent valve (200) from each cell.
- (2) Remove and replace O-rings (210) from the vent valves (200).
- (3) Using [T01](#) finger tighten the vent valve (200) securely in place. Do not over-tighten.



## COMPONENT MAINTENANCE MANUAL

40176-4 / 40176-7

### F. Sensor harness replacement

- (1) 40176-4 Sensor harness ([040](#))
  - (a) Remove the upper hex nuts ([130](#)), washers ([134](#)) and links ([220](#)), ([250](#)).
  - (b) Remove link ([250](#)) from the cells and then remove the hex nut ([060](#)).
  - (c) Remove the power connector ([280](#)) and gasket ([300](#)) from the battery case ([010](#), or [010A](#)) by removing screws ([290](#)).
  - (d) Remove the connector nut ([080](#)) and O-ring ([090](#)) of the sensor harness ([040](#)) from the battery case ([010](#) or [010A](#)).
  - (e) Install the O-ring ([090](#)) onto harness connector before placing the connector through the hole in the battery case ([010](#) or [010A](#)). Install nut ([080](#)) and torque per [Table 8001](#).
  - (f) Install sensor harness ([040](#)) into the battery case ([010](#) or [010A](#)) by installing the connector nut ([080](#)) and O-ring ([090](#)). Torque per [Table 8001](#).
  - (g) Place the gasket ([300](#)) onto the power connector ([280](#)) and insert terminals through the oval mounting hole in the front of the battery case ([010](#) or [010A](#)) and installing screws ([290](#)). Secure the receptacle by torquing the screws ([290](#)) per [Table 8001](#).
  - (h) Install links ([220](#)), ([250](#)) onto cells, then install washers ([134](#)) and upper hex nuts ([130](#)). Torque per [Table 8001](#).
  - (i) Lightly lube with [M02](#) the nuts, links, connector contact and all components that might be susceptible to atmospheric corrosion.
- (2) 40176-7 Sensor harness ([050](#))
  - (a) Remove the upper hex nuts ([130](#)), washers ([134](#)), and links ([220](#)), ([250](#)), ([270](#)).
  - (b) Remove links ([250](#)), ([270](#)) from the cells and then remove hex nuts ([070](#)).
  - (c) Remove the power connector ([280](#)) and gasket ([300](#)) from the battery case ([010](#), or [010A](#)) by removing screws ([290](#)).
  - (d) Remove the connector nut ([080](#)) and O-ring ([090](#)) of the sensor harness ([050](#)) from the battery case ([010](#) or [010A](#)).
  - (e) Install new Saft sensor harness ([050](#)) by installing the hex nuts ([070](#)) onto links ([250](#)) and ([270](#)). Torque per [Table 8001](#).
  - (f) Install the O-ring ([090](#)) onto harness connector before placing the connector through the hole in the battery case ([010](#) or [010A](#)). Install nut ([080](#)) and torque per [Table 8001](#).
  - (g) Place the gasket ([300](#)) onto the power connector ([280](#)) and insert terminals through the oval mounting hole in the front of the battery case ([010](#) or [010A](#)) and installing screws ([290](#)). Secure the receptacle by torquing the screws ([290](#)) per [Table 8001](#).
  - (h) Install links ([220](#)), ([250](#)), ([270](#)) onto cells, then install washers ([134](#)) and upper hex nuts ([130](#)). Torque per [Table 8001](#).
  - (i) Lightly lube with [M02](#) the nuts, links, connector contact and all components that might be susceptible to atmospheric corrosion.

**24-32-03**

6003  
Aug 4/21



COMPONENT MAINTENANCE MANUAL  
40176-4 / 40176-7

- G. Power connector (280) replacement
- (1) Remove the upper hex nuts (100), (130), washers (110), (134), and links (220).
  - (2) Remove and replace the power connector (280) and its gasket (300) from the battery case (010 or 010A) by removing screws (290).
  - (3) Place the gasket (300) onto the power connector (280) and insert terminals through the oval mounting hole in the front of the battery case (010 or 010A) and installing screws (290). Secure the receptacle by torquing the screws (290) per [Table 8001](#).
  - (4) Install links (220), washers (110), (134), and upper hex nuts (100), (130). Torque nuts per [Table 8001](#).
- H. Battery cover (020) and case (010 or 010A) minor dents.
- When necessary, remove minor dents in the battery cover (020) and battery case (010 or 010A) using a hard rubber mallet. Polish out minor pits or scratches using a fine grain abrasive porous cloth.



COMPONENT MAINTENANCE MANUAL  
40176-4 / 40176-7  
**ASSEMBLY**

1. General

This section contains assembly instructions necessary after disassembly.

**NOTE:** Make sure all components are clean and dry before re-assembly.

**NOTE:** All ( ) part identification numbers herein are IPL [Figure 1](#) item numbers.

2. Sensor harness (040 or 050)

- A. Install the O-ring (090) onto harness connector before placing the connector through the hole in the battery case (010 or 010A). Install nut (080) and torque per [Table 8001](#).
- B. For sensor harness (040), secure and torque the sensor lug in place on link (250) with nut (060), refer to [Table 8001](#).
- C. For sensor harness (050), secure and torque the sensor lug in place on links (250) and (270) with nuts (070), refer to [Table 8001](#).

3. Power connector (280)

- A. Place the gasket (300) onto the power connector (280) and insert terminals through the oval mounting hole in the front of the battery case (010 or 010A) and installing screws (290). Secure the receptacle by torquing the screws (290) per [Table 8001](#).

4. Spacers (310) and cells (120)

Install spacers (310) and cell assemblies (120) into the battery case (010 or 010A), using the following steps. Refer to [Figure 7001](#) or [Figure 7002](#).

- A. Insert one edge of bottom spacer into battery case (010 or 010A) from the left or right side, then slide the spacer under the cell partition.

**NOTE:** Cell insertion is typically easier when a middle cell is the last installed in each row.

- B. Install the left and right side row of cells (120) and spacers (310) in accordance to [Figure 7001](#) and [Figure 7002](#). Be sure to maintain the proper cell arrangement and polarity orientation as shown in [Figure 7002](#). Insertion of the last cell on each side is sometimes difficult and can be assisted by pushing down on the terminals with a small block of soft wood.

**NOTE:** Spacers are used as required to ensure the cells are retained securely in place. As indicated in [Figure 7001](#), the maximum quantity to be used is as shown.

- C. Install the center row of cells (120) and spacers (310) in accordance to [Figure 7001](#) and [Figure 7002](#). Be sure to maintain the proper cell arrangement and polarity orientation as shown in [Figure 7002](#). Insertion of the last cell is sometimes difficult and can be assisted by pushing down on the terminals with a small block of soft wood.
- D. Torque the lower hex nuts (140) of the cell assemblies (120) per [Table 8001](#).
- E. Apply a small amount of [M02](#) to the threads of the cell terminals.

**24-32-03**

7001  
Aug 4/21

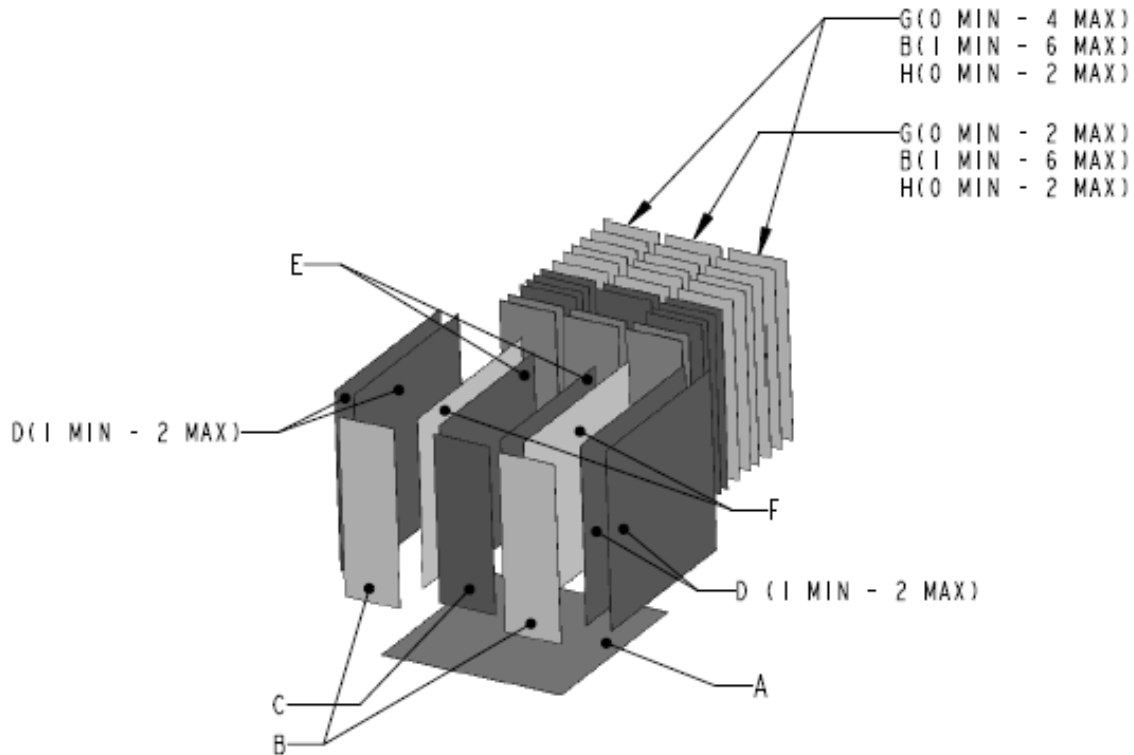

Item	Description	Dimension (in)	Unit Per Assembly
A	Spacer	9.580 x 9.780 x 0.015	1
B	Spacer	2.953 x 9.173 x 0.020	20
C	Spacer	2.953 x 8.610 x 0.032	1
D	Spacer	9.646 x 9.173 x 0.032	4
E	Spacer	8.268 x 8.661 x 0.032	2
F	Spacer	9.646 x 8.661 x 0.020	2
G	Spacer	2.953 x 9.173 x 0.032	10
H	Spacer	2.953 x 9.173 x 0.062	6

Spacer Kit (310) Installation  
Figure 7001

## COMPONENT MAINTENANCE MANUAL 40176-4 / 40176-7

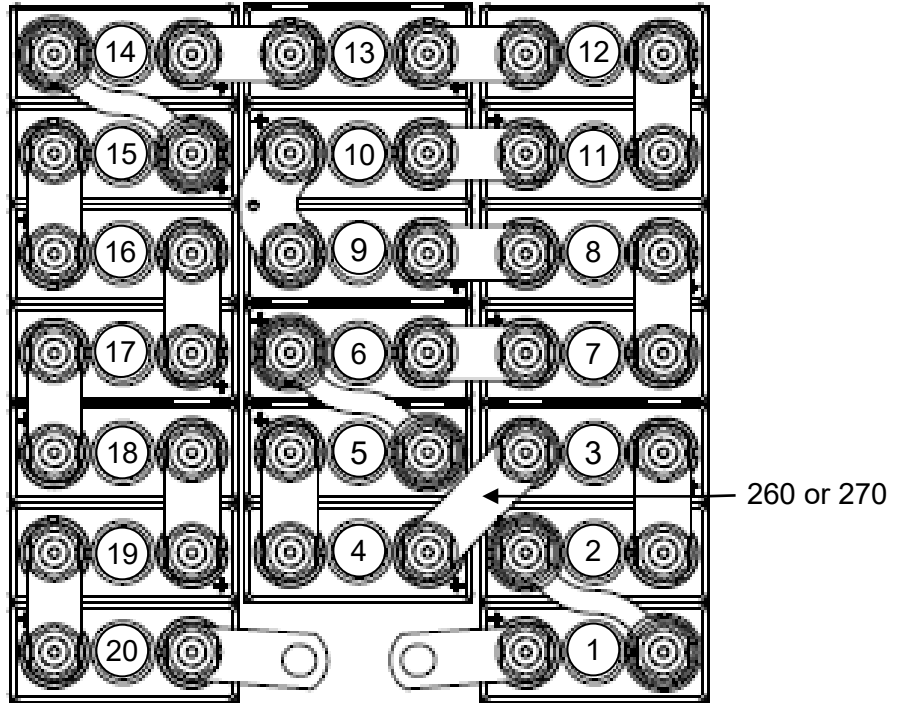

Cell Number, Polarity and Sensor Orientation  
Figure 7002



5. Complete battery

- A. Install intercell terminal links (220), (230), (240), (250), (260 or 270) on the terminals of the cell sub-assemblies (120) in Figure 7002. Reference Figure 7003 for applicable wire routing.

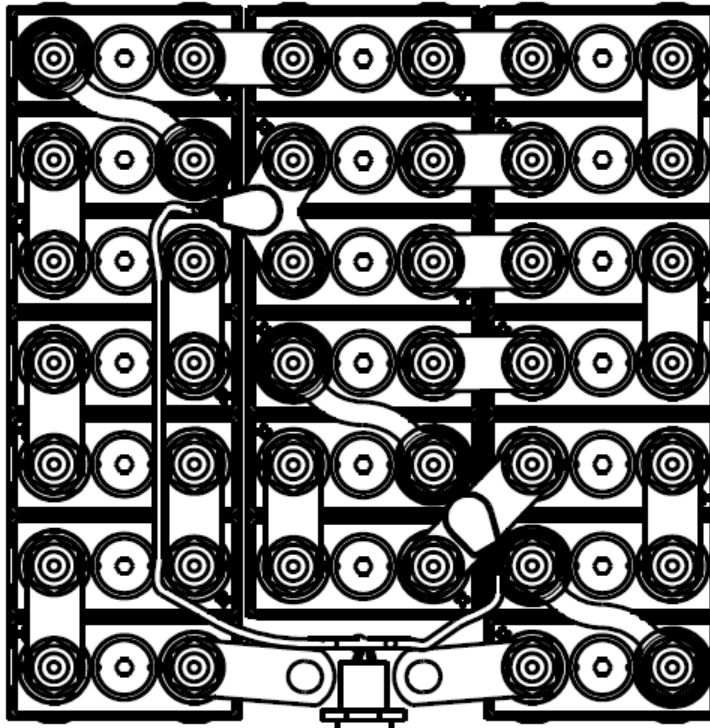

Sensor Harness Routing  
Figure 7003

- B. Install the washers (110), (134) and upper hex nuts (100), (130) onto the terminals of the cell assemblies (120) and power connector adapter (280). Torque nuts per Table 8001.

**CAUTION:** DO NOT CRIMP OR PINCH WIRE LEAD/LUG ASSEMBLIES OF THE SENSOR HARNESS.

- C. Lightly lube with M02 the nuts, links, connector contact and all components that might be susceptible to atmospheric corrosion.
- D. Install the battery cover (020) and pad (030) onto the battery case (010 or 010A) and secure in place by fastening the latches.



COMPONENT MAINTENANCE MANUAL  
40176-4 / 40176-7

**FITS AND CLEARANCES**

1. Torque Table

ITEM NUMBER	TORQUE VALUE		NAME, LOCATION
	N-m	lb <sub>f</sub> -in	
<a href="#">290</a>	2.3 ± 0.2	20 ± 2	Screw, Sems
<a href="#">110, 130</a>	13.0 ± 1.0	115 ± 9	Nut, Upper
<a href="#">060, 070</a>	1.1 ± 0.1	10 ± 1	Nut, Locking
<a href="#">080</a>	5.6 ± 0.6	50 ± 5	Nut, Connector
<a href="#">140</a>	5.0 ± 0.5	44 ± 4	Nut, Lower

Torque Values  
Table 8001

2. Fits and Clearances Table

No fits and clearances required.



COMPONENT MAINTENANCE MANUAL  
40176-4 / 40176-7

PAGE INTENTIONALLY LEFT BLANK

**24-32-03**

Blank  
Aug 4/21



COMPONENT MAINTENANCE MANUAL  
40176-4 / 40176-7

**SPECIAL TOOLS, FIXTURES, EQUIPMENT, AND CONSUMABLES**

1. Special Tools

A. Battery maintenance kit

**NOTE:** Equivalent tools can be used.

**NOTE:** A special tool kit (P/N 416161) is available from Saft containing special tools T01, T02, T03, and T04. From the special tool kit (P/N 416161), T02 is assembled using syringe P/N 105212 and nozzle P/N 016544. The tools are housed in a polypropylene box and each tool is insulated to ensure optimum safety for the technician.

- (1) The syringe [T02](#) is used in the electrolyte level adjustment and the cell puller [T04](#) is used in cell removal.

ITEM	DESCRIPTION	V09052 P/N	F6177 P/N
T01	Universal vent wrench	093365-000	413876
T02	Syringe assembly (with nozzle 20 mm (0.79 in))	020915-004	416231
T03	1 $\Omega$ 3 W equalizing resistors	-	164829
T04	Universal cell extraction tool or M10x1.25 tool	017556-000	416159
T05	Vent Valve adapter for M8 valves	025098-000	-

Special Tools  
Table 9001

2. Standard Tools

A. The following items are recommended to do the procedures described in this manual. When necessary equivalent substitutes may be used.

- Constant current charger (DC current range 0 – 60A, minimum open DC voltage 40V)
- Constant current load bank (DC current range 0 – 60 A, DC voltage range 1 – 40V)
- Megohmmeter (0 – 50 M $\Omega$  @ 250 V DC continuous)
- Precision Multimeter (Volt,  $\Omega$ , mA) 2000 count, accuracy 1% or better
- Torque Wrench (Insulated) 0 to 15 N-m (0 to 133 lbf-in)
- Thermometer, Immersion
- Standard mechanic's tools.
- Safety gloves.
- Protective goggles.
- Safety shoes.
- Eye wash.
- Protective apron.
- Stiff bristle brush (non-metallic)
- Small paintbrush (non-metallic)



COMPONENT MAINTENANCE MANUAL  
40176-4 / 40176-7

- Dry, compressed air source [less than 1.38 bar (20 psi)]
- Soft, clean cloth (at least two required)

3. Consumables

This paragraph describes the consumables used in the CMM.

**NOTE:** Equivalent alternatives can be used for list items.

ITEM	DESIGNATION PART NUMBER AND SPECIFICATION DESCRIPTION	MANUFACTURER OR SUPPLIER (NAME, ADDRESS, CODE)
M01	Distilled or deionized water @ +20°C ± 5°C (68°F ± 9°C): Clear, colorless, and odorless while boiling Conductivity < 33 µS/cm 5 < pH < 7 Mn-COD < 30 mg/l (1.7 x 10 <sup>-5</sup> oz/in <sup>3</sup> ) (Chemical Oxygen Demand, methodology to evaluate organic or mineral pollution) Chlorines Cl <sup>-</sup> < 5 mg/l (2.9 x 10 <sup>-6</sup> oz/in <sup>3</sup> ) Sulfates SO <sub>4</sub> <sup>2-</sup> < 10 mg/l (5.8 x 10 <sup>-6</sup> oz/in <sup>3</sup> )  STORAGE: dry and clean container without any corrosion and damage; Temperature: +20°C ± 5°C (+68°F ± 9°C). Over 1 year of storage, do an analysis of the liquid.	Local Vendor
M02	Neutral petroleum jelly Density @ +60°C (+140°F) Range = 0.840 - 0.866 Kg/L (0.486 - 0.501 oz/in <sup>3</sup> ) Melting Point Range = 46°C to 52°C (+115°F to +126°F) Acidity/Alkalinity = Neutral to Litmus	Mineral Vaseline NATO: S 743 F: AIR 3565 US: VV-P-236A UK: DEF 2333
M03	Mild soap	Local Vendor

Consumables  
Table 9002



COMPONENT MAINTENANCE MANUAL  
40176-4 / 40176-7

**ILLUSTRATED PARTS LIST**

1. Introduction

A. Purpose

This section provides illustrations and parts breakdown of the 40176-4 / 40176-7 batteries, which can be disassembled, replaced, and reassembled.

B. Explanation and usage of section

(1) Assembly order indenture system

The Indenture System used in the parts list shows the relationship of one part to another. For a given item, the number of indentures depicts the relationship of the item to the associated next higher assembly.

(2) Effectively code

Reference letters (A, B, C, etc.) are assigned in the EFF CODE column to each top assembly. The reference letter of the applicable top assembly is also shown in the EFF CODE column for each detail part and subassembly except that no reference letter is shown for detail parts and subassemblies used on all top assemblies.

(3) Quantity per assembly

The UNITS PER ASSY column shows the total number of units required per assembly, per subassembly, and per sub-subassembly as applicable. The letters REF indicates the item is listed for reference purposes.

(4) Parts replacement data

Interchangeability information will be provided in a future manual revision if it becomes applicable.

(5) Service Bulletin incorporation

Service Bulletin incorporation information applicable to the parts list will be provided in a future manual revision if it becomes applicable.

(6) Items not illustrated

Items not illustrated are indicated by a dash ( - ) ahead of the item numbers in the Figure and Index column.

(7) Alpha variant item numbers

(a) Alpha variants A - Z (except I and O) are assigned to existing item numbers when necessary to show:

1. Added items

2. Service Bulletin modifications

3. Configuration differences

4. Optional parts

5. Product improvement parts (non-service bulletin)

**24-32-03**

10001  
Aug 4/21



## COMPONENT MAINTENANCE MANUAL

40176-4 / 40176-7

- (b) Alpha variant item numbers are not shown on the exploded view when the appearance and location of the alpha variant item is the same as the basic item.

(8) Vendors

The vendor of all parts shown in the parts list is as follows:

Vendor Code	NAME / ADDRESS	Vendor Code	NAME / ADDRESS
<b>V09052</b>	Saft America Inc. 711 Gil Harbin Industrial Boulevard Valdosta, GA 31601 USA Phone: +1 (229) 247-2331 Fax: +1 (229) 247-8486	<b>F6177</b>	Saft 126 quai Charles Pasqua 92300 Levallois-Perret France Phone: +33 1 58 63 16 00 Fax: +33 1 58 63 16 18

**24-32-03**

10002  
Aug 4/21



COMPONENT MAINTENANCE MANUAL  
40176-4 / 40176-7

2. Numeric Index

<b>PART NUMBER V09052</b>	<b>AIRLINE STOCK NUMBER</b>	<b>FIGURE NUMBER</b>	<b>ITEM NUMBER</b>	<b>UNIT</b>	<b>UNITS PER ASSY</b>
MS3186A107W			080	EA	1
M25988-3-019			090	EA	1
009384-000			300	EA	1
015575-000			230	EA	13
015576-000			240	EA	3
015577-000			220	EA	2
015578-000			260	EA	1
015579-000			100, 130, 140	EA	82
015602-000			120	EA	20
015920-000		1	1	EA	RF
015924-003			020	EA	1
015926-000			250	EA	1
015945-000			030	EA	1
015949-000			040	EA	1
015957-000			200	EA	20
016392-000		1	1A	EA	RF
016420-000			050	EA	1
016423-000			270	EA	1
019736-000			310	EA	1
021751-000			010	EA	1
021752-000			010A	EA	1
021870-000			180	EA	40
021871-000			170	EA	80
022078-000			280	EA	1
022228-000			110, 134	EA	42
023388-001			160	EA	20
023388-002			150	EA	20
091180-008			210	EA	20
091181-002			190	EA	40
093169-000			060, 070	EA	2
093616-000			290	EA	4

**24-32-03**

10003  
Aug 4/21



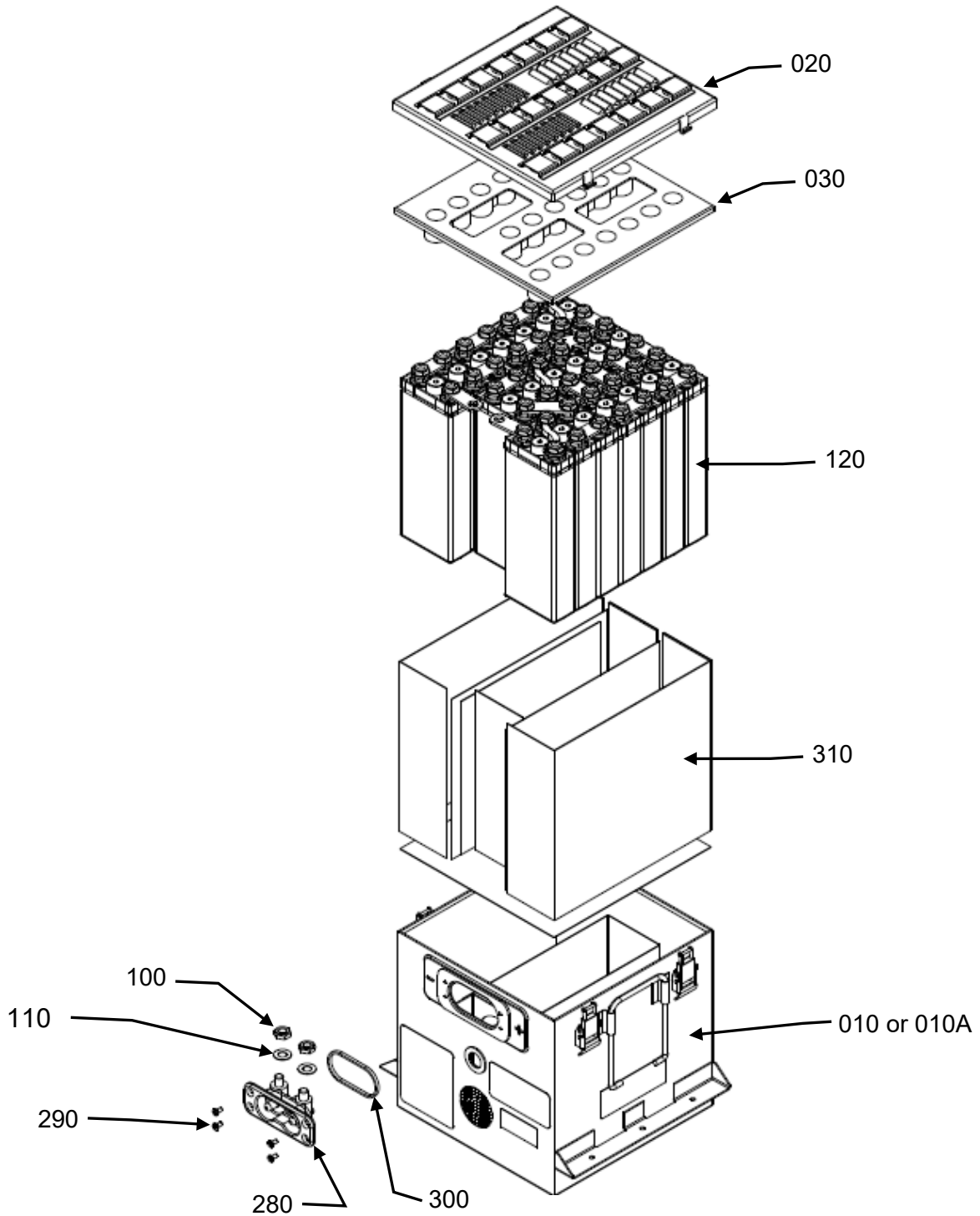

Battery, Exploded View  
Figure 1 (Sheet 1 of 4)

## COMPONENT MAINTENANCE MANUAL 40176-4 / 40176-7

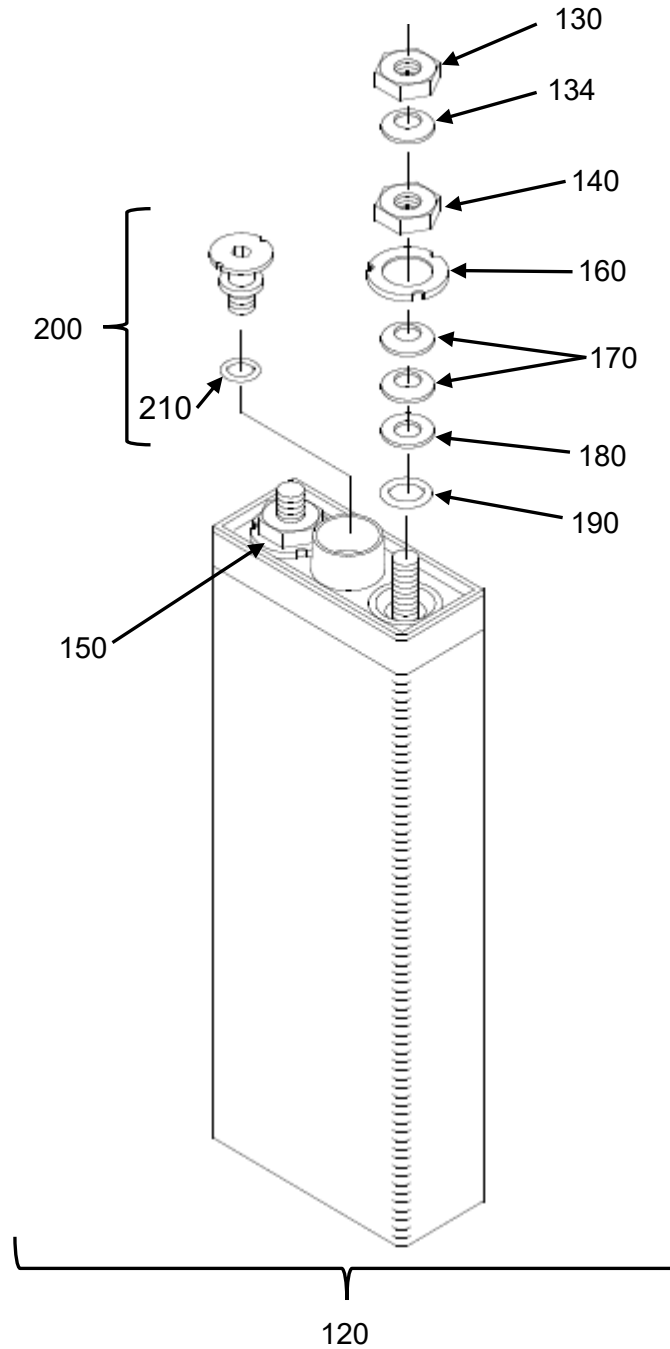

Battery, Exploded View  
Figure 1 (Sheet 2 of 4)

## COMPONENT MAINTENANCE MANUAL 40176-4 / 40176-7

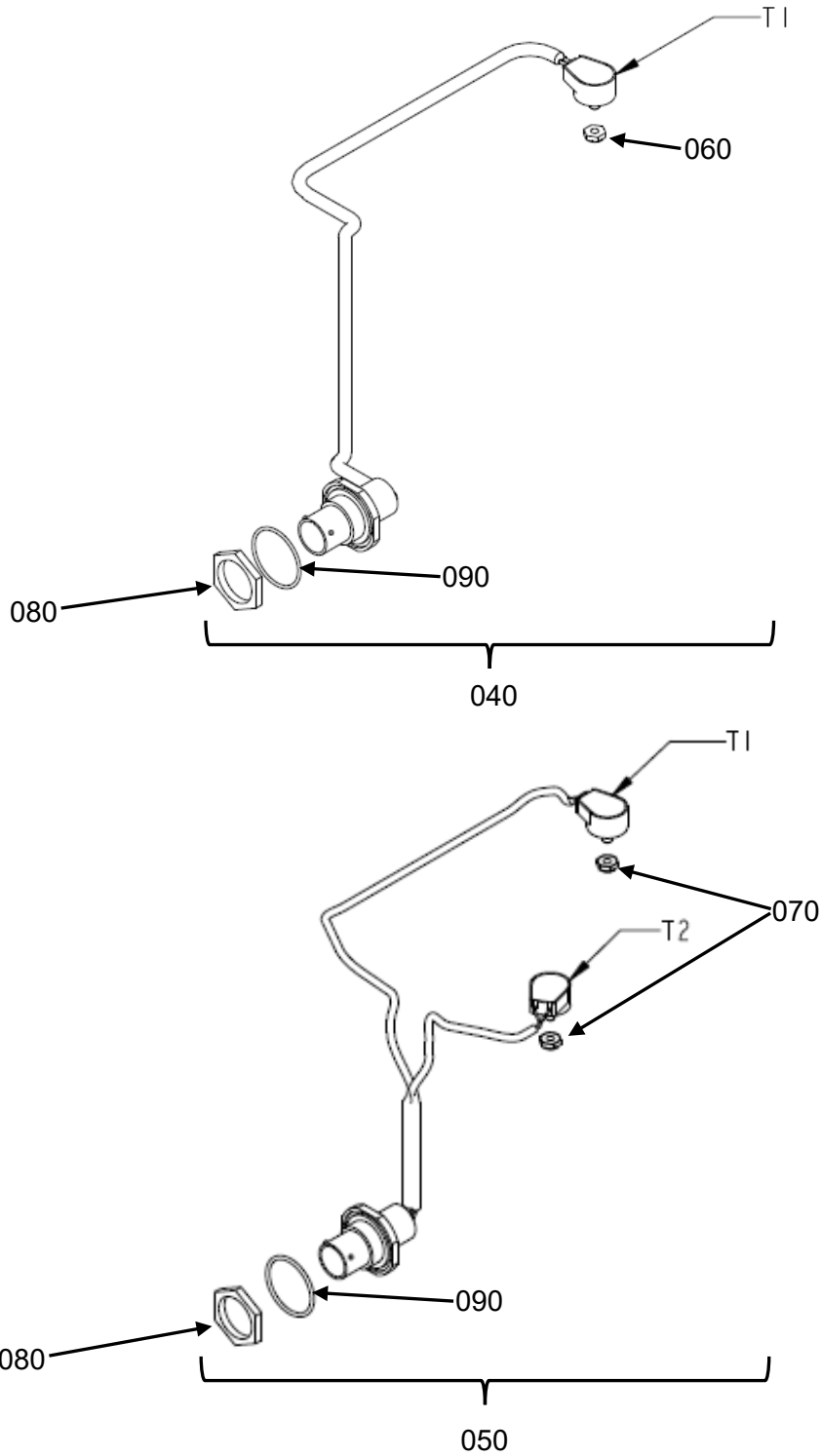

Battery, Exploded View  
Figure 1 (Sheet 3 of 4)

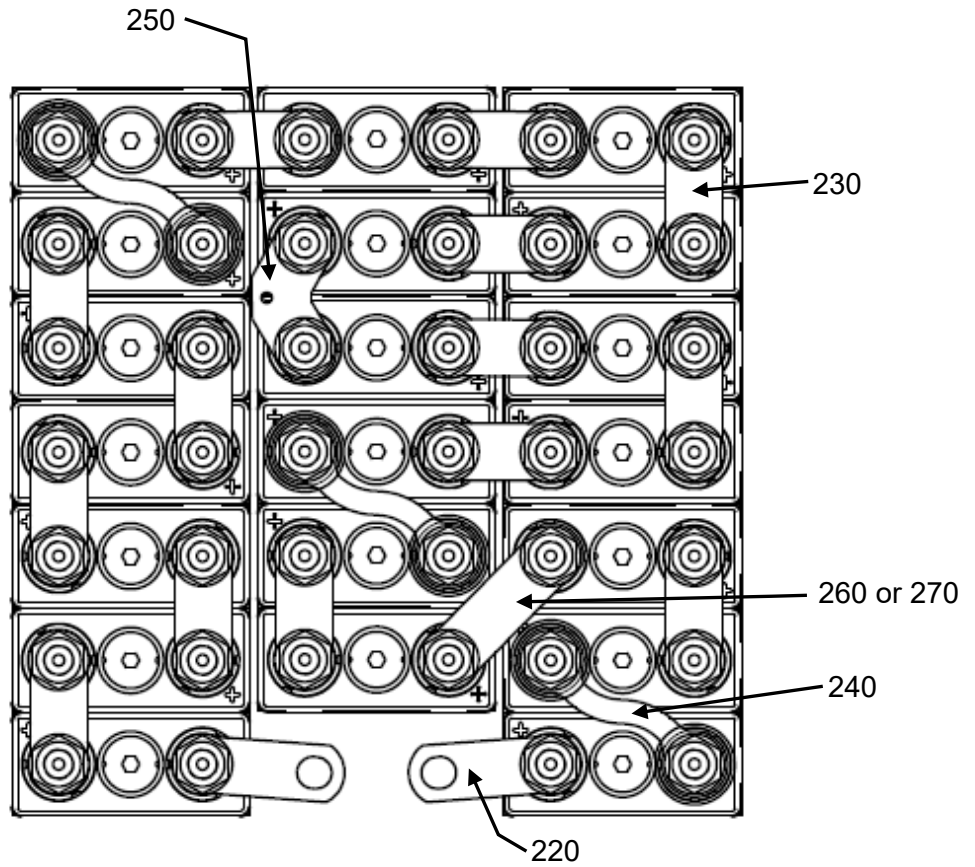

Battery, Top View

Battery, Exploded View  
Figure 1 (Sheet 4 of 4)



COMPONENT MAINTENANCE MANUAL  
40176-4 / 40176-7

3. Detail Parts List

FIGURE & ITEM	PART NUMBER	AIRLINE PART NO.	NOMENCLATURE 1234567 .....	EFF CODE	UNITS PER ASSY
1	015920-000		<b>BATTERY, 40176-4</b>	A	RF
1A	016392-000		<b>BATTERY, 40176-7</b>	B	RF
010	021751-000		. Case, Marked, 40176-4	A	1
010A	021752-000		. Case, Marked, 40176-7	B	1
020	015924-003		. Cover		1
030	015945-000		. Pad, Holddown		1
040	015949-000		. Sensor, Harness	A	1
050	016420-000		. Sensor, Harness	B	1
060	093169-000		. . Nut, Thermostat		1
070	093169-000		. . Nut, Thermostat	B	2
080	MS3186A107W		. . Nut, Sensor Connector		4
090	M25988-3-019		. . O-Ring, Sensor M25988/3-019		1
100	015579-000		. Nut, Hex, Power Connector		2
110	022228-000		. Washer, Belleville		2
120	015602-000		. Cell, VP400KH w/hardware		20
130	015579-000		. . Nut, Hex, Upper		2
134	022228-000		. . Washer, Belleville		2
140	015579-000		. . Nut, Hex, Lower		2
150	023388-002		. . Washer, Negative		1
160	023388-001		. . Washer, Positive		1
170	021871-000		. . Washer, Belleville		4
180	021870-000		. . Washer, Flat		2
190	091181-002		. . O-Ring, Terminal		2
200	015957-000		. . Valve, Vent		1
210	091180-008		. . . O-Ring, Vent-Valve		1
220	015577-000		. Link		2
230	015575-000		. Link		14
240	015576-000		. Link		3
250	015926-000		. Link		1
260	015578-000		. Link	A	1
270	016423-000		. Link	B	1
280	022078-000		. Connector, Power		1
290	093616-000		. Screw, Sems		4
300	009384-000		. Gasket, Power Connector		1
310	019736-000		. Kit, Spacer		1

**24-32-03**

10008  
Aug 4/21



COMPONENT MAINTENANCE MANUAL  
40176-4 / 40176-7

**STORAGE (INCLUDING TRANSPORTATION)**

1. Introduction

- A. Storage preparation and packaging makes sure that the equipment is protected against any attack by atmospheric agents.
- B. For a battery which has been cleaned and serviced and is not directly put into service on board an aircraft, different methods can be recommended depending on the purpose and the environment conditions of the "storage".
- C. Keep the batteries and spares in a dry and clean room.

2. Inactive Long-Term Storage

A. Procedure

- (1) The battery should be stored filled and discharged. It is not necessary that it be short circuited. There is no need of maintenance operation during the storage period.

**NOTE:** The standard cardboard packaging is considered unsealed and allows 2 years of storage. Storage is allowed for 10 years if the following conditions are met: sealed packaging and isolated from harmful agents (i.e.: dirt, dust, vibrations, or corrosive atmosphere).

- sealed packaging,
- temperature: +5°C to +35°C (+41°F to +95°F),
- humidity < 90 %,
- normal vertical position,
- Isolated from detrimental agents: i.e., dirt, dust, dampness, vibration, corrosive atmosphere.

- (2) Saft Ni-Cd batteries may be stored in temperatures ranging from -55°C to +5°C (-67°F to +41°F) or +35°C to +60°C (+95°F to +140°F) for an accumulated exposure that does not exceed 30 days.

- (3) Lead batteries must not be stored in the same room.

B. Servicing at end of long-term storage

STORAGE TIME	SERVICE PROCEDURE
Less than or equal to 12 months	Battery must have recently passed the capacity criteria of <a href="#">Table 1004</a> before entering storage, <a href="#">Visual inspection</a> , <a href="#">Figure 1002</a> Entry Point " <a href="#">C</a> "
More than 12 months	<a href="#">Figure 1002</a> Entry Point " <a href="#">Regular Check</a> "

Return to Service Following Storage  
Table 15001

### 3. Inactive Standby Storage

The battery is charged after being serviced then stored fully charged in a dedicated room in such a way that it can be installed in the aircraft without further maintenance except as provided within this section. Refer to [Figure 15002](#).

**NOTE:** At any time during the Inactive standby storage shown in [Figure 15002](#), the battery may be installed on the aircraft or placed into [Inactive Long-Term Storage](#).

**NOTE:** For a battery previously stored at a temperature below ambient temperature, condensation within the battery may occur, do [Battery insulation](#) before installation.

A. Standby period is the duration that corresponds to 80% available capacity shown in [Figure 15001](#). For example, maximum of 24 days at +30°C (+86°F) or maximum of 90 days for temperatures  $\leq$  +23°C (+73°F).

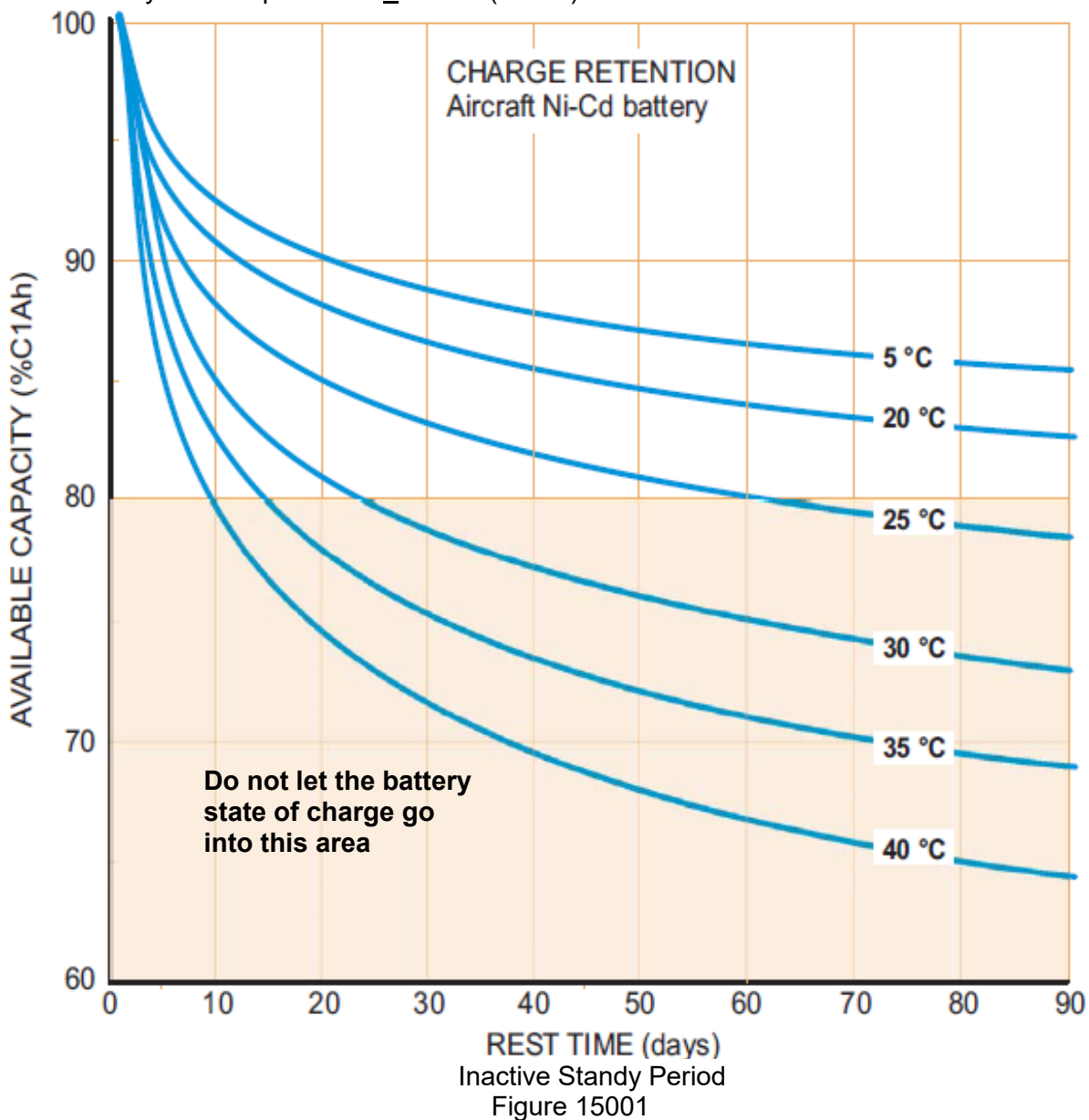



COMPONENT MAINTENANCE MANUAL  
40176-4 / 40176-7

- B. Refresh charge is a quick constant current charge that can be done at the end of a [Standby period](#) to extend the time the battery is in inactive standby storage. The charge is given in [Table 15002](#).

**CAUTION:** DO NOT DO THE 4 HOURS OVERCHARGE AT 0.1 C<sub>1</sub>A (REFER TO [CHARGE](#)) DURING THIS 'REFRESH' CHARGE OPERATION.

CHARGE RATE	VOLTAGE (END OF "REFRESH" CHARGE)
0.1C <sub>1</sub> A	30.0V for 20 Cells
0.5C <sub>1</sub> A	31.0V for 20 Cells
1.0C <sub>1</sub> A	31.4V for 20 Cells

Refresh Charge  
Table 15002

- C. Standby duration consists of a maximum of 3 standby periods with 2 refresh charges in-between each standby period. The number of consecutive standby durations is limited to 3. Refer to [Figure 15002](#).
- (1) For a battery completing the first or second standby duration and not immediately installed in the aircraft or sent into long-term storage, do one the following below:
    - (a) For environments  $\leq +30^{\circ}\text{C}$  ( $+86^{\circ}\text{F}$ ) do [Battery insulation](#), [Initial discharge](#), [Charge](#), [Electrolyte level](#), and [Battery insulation](#).
    - (b) For environments  $> +30^{\circ}\text{C}$  ( $+86^{\circ}\text{F}$ ) do [Battery insulation](#), [Initial discharge](#), [Cell shorting](#), [Charge](#), [Electrolyte level](#), and [Battery insulation](#).
  - (2) For a battery completing the third consecutive standby duration, the battery can go into long-term storage (refer to [Inactive Long-Term Storage](#)) or return to [Figure 1002](#).
- D. Inactive standby storage schedule is limited to the [Standby duration](#) being conducted a maximum of 3 times as shown in [Figure 15002](#).

**NOTE:** At any time during the Inactive standby storage schedule shown in [Figure 15002](#), the battery may be installed on the aircraft or placed into [Inactive Long-Term Storage](#).





COMPONENT MAINTENANCE MANUAL  
40176-4 / 40176-7

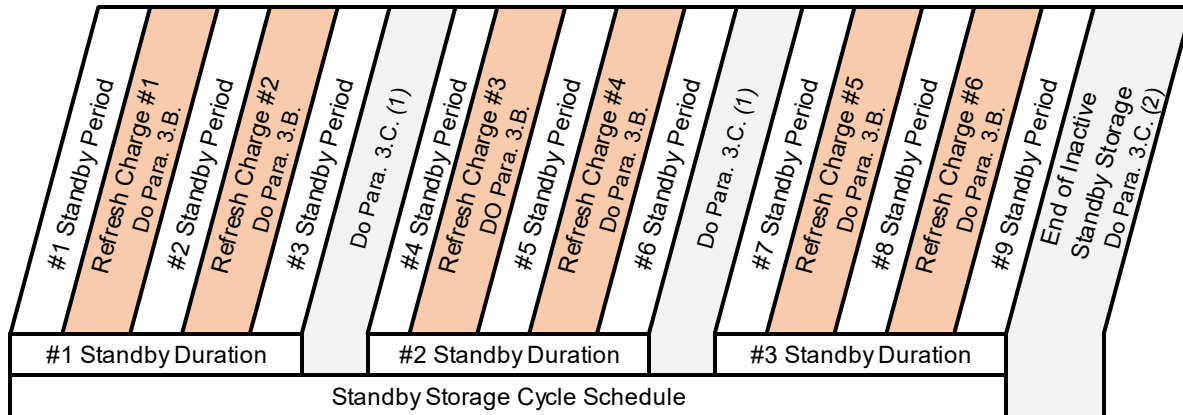

Inactive Standby Storage Schedule  
Figure 15002

4. Active Standby Mode (Trickle Charge)

**CAUTION:** WATER CONSUMPTION OCCURS WHEN THE BATTERY IS CONTINUOUSLY CHARGED, IN AN FINAL CHARGE CONDITION. SAFT DOES NOT RECOMMEND THIS METHOD, HOWEVER SOME OPERATORS TAKE RESPONSIBILITY FOR ITS USE.

**NOTE:** This method is not reliable due to quantity and inaccuracy of water consumption.

Example: A 40 Ah battery on a continuous trickle charge of 3 mA/Ah for one month may consume over 35 cm<sup>3</sup>/cell (2.14 in<sup>3</sup>/cell) water total.

5. Transportation Procedure

The battery is normally discharged before packing. If it is necessary to transport a charged battery, make sure that the output terminals are protected against short circuit.

The battery should then be packed vertically in its original container. If the original container is not available, the international and/or local packaging regulations applicable to the mode of transport and destination must be followed.

According to the IATA / IMDG dangerous goods regulations, Saft ships all existing nickel-cadmium batteries or cells for aircraft under the classification UN2795 (wet, filled with alkali) according to packing instruction 800.