



To: HOLDERS OF COMPONENT MAINTENANCE MANUAL 24-38-51, 2758

Subject: CMM Revision No. 6 Dated Sep 21/2023

Replace revised pages by adding or removing pages for pages dated Sep 21/2023

NOTE: The CMM can be downloaded from the internet at <https://saft4u.saft.com>

HIGHLIGHTS

CHAPTERS/SECTION PAGE NUMBER	DESCRIPTION OF CHANGE
Title Page T-1	Revision level updated Drawing number removed
Record of Revisions ROR-1	New revision added
List of Effective Pages LEP-1	Date updated for modified pages

PAGE INTENTIONALLY LEFT BLANK



(F6177)

26 quai Charles Pasqua - 92300 Levallois-Perret - France
Tél. +33 1 58 63 16 90 - Fax: +33 1 58 63 16 18

COMPONENT MAINTENANCE MANUAL WITH ILLUSTRATED PARTS LIST

AIRCRAFT BATTERY

2758

date of creation: Oct 01/1987

24-38-51

edition 6
Sep 21/2023



**Component Maintenance Manual
2758**

This document and all information contained herein are the property of Saft. Its use is restricted solely to the maintenance of Saft batteries and may under no circumstances be used for any other manufacturer's products. No person may, in whole or in part, duplicate, use or disclose this information for any other purpose without the prior written consent of Saft.

RECORD OF REVISION

Rev. n°	Issue date	Inserted		Rev. n°	Issue date	Inserted	
		Date	By			Date	By
1	Dec 89	Dec 89	Saft				
2	Feb 90	Feb 90	Saft				
3	Jun 15/95	Jun 15/95	Saft				
4	Apr 08/2013	Apr 08/2013	Saft				
5	Aug 21/2023	Aug 21/2023	Saft				
6	Sep 21/2023	Sep 21/2023	Saft				

PAGE INTENTIONALLY LEFT BLANK

RECORD OF TEMPORARY REVISION

Rev. n°	Issue date	Inserted		Rev. n°	Issue date	Inserted	
		Date	By			Date	By

PAGE INTENTIONALLY LEFT BLANK

SERVICE BULLETIN LIST

Service bulletin		Incorporation into CMM		Title
Number	Rev.	Date	Rev.	

PAGE INTENTIONALLY LEFT BLANK

LIST OF EFFECTIVE PAGES

TITLE PAGE	1	Sep 21/2023	DESCRIPTION AND OPERATION	1	Apr 08/2013
	2	Apr 08/2013		2	Apr 08/2013
RECORD OF REVISIONS	ROR-1	Sep 21/2023	TESTING AND FAULT ISOLATION	3	Apr 08/2013
	ROR-2	Blank		4	Apr 08/2013
	ROR-1	Apr 08/2013		1001	Apr 08/2013
	ROR-2	Blank		1002	Apr 08/2013
RECORD OF TEMPO- RARY REVISIONS	RTR-1	Apr 08/2013		1003	Apr 08/2013
	RTR-2	Blank		1004	Blank
SERVICE BULLETIN LIST	SBL-1	Apr 08/2013	DISASSEMBLY	3001	Apr 08/2013
	SBL-2	Blank		3002	Apr 08/2013
LIST OF EFFECTIVE PAGES	LEP-1	Sep 21/2023	CLEANING	4001	Apr 08/2013
	LEP-2	Aug 21/2023		4002	Apr 08/2013
TABLE OF CON- TENTS	TOC-1	Apr 08/2013			
	TOC-2	Apr 08/2013			
	TOC-3	Apr 08/2013			
	TOC-4	Blank			
LIST OF ILLUSTRA- TIONS	LOI-1	Apr 08/2013			
	LOI-2	Blank			
INTRODUCTION	Intro-1	Apr 08/2013			
	Intro-2	Apr 08/2013			
	Intro-3	Apr 08/2013			
	Intro-4	Apr 08/2013			
	Intro-5	Apr 08/2013			
	Intro-6	Blank			

Component Maintenance Manual 2758

INSPECTION/CHECK	5001	Apr 08/2013	ILLUSTRATED	10001	Apr 08/2013
	5002	Apr 08/2013	PARTS LIST	10002	Apr 08/2013
	5003	Apr 08/2013		10003	Apr 08/2013
	5004	Apr 08/2013		10004	Apr 08/2013
	5005	Apr 08/2013		10007	Apr 08/2013
	5006	Apr 08/2013		10006	Apr 08/2013
	5007	Apr 08/2013			
	5008	Apr 08/2013	STORAGE (INCLU-	15001	Apr 08/2013
	5009	Aug 21/2023	DING TRANSPORTA-	15002	Apr 08/2013
	5010	Apr 08/2013	TION)		
ASSEMBLY	7001	Apr 08/2013			
	7002	Apr 08/2013			
	7003	Apr 08/2013			
	7004	Apr 08/2013			
FITS AND CLEARANCES	8001	Apr 08/2013			
	8002	Blank			
SPECIAL TOOLS, FIXTURES, EQUIPMENT AND CONSUMABLE	9001	Apr 08/2013			
	9002	Apr 08/2013			

TABLE OF CONTENTS

RECORD OF REVISION	ROR-1
RECORD OF TEMPORARY REVISION	RTR-1
SERVICE BULLETIN LIST	-SBL-1
LIST OF EFFECTIVE PAGES	-LEP-1
TABLE OF CONTENTS	TOC-1
LIST OF ILLUSTRATIONS	-LOI-1
INTRODUCTION	INTRO-1
1. General	INTRO-1
2. Website	INTRO-1
3. Definitions	INTRO-1
4. Safety	INTRO-1
4-1. Physical	INTRO-1
4-2. Electrical	INTRO-1
4-3. Chemical	INTRO-1
5. Aircraft Conversions	INTRO-2
6. Ground Applications	INTRO-2
7. Placing a new battery in service - initial commissioning	INTRO-2
8. Battery Ratings	INTRO-3
8-1. Capacity	INTRO-3
9. Recycling	INTRO-3
10. End of life cells	INTRO-3
11. Measurements	INTRO-4
11-1. Units of Measure	INTRO-4
11-2. Measurement Conversion Table	INTRO-4
11-3. Temperature Conversion Table	INTRO-5
11-4. Abbreviations	INTRO-5
DESCRIPTION AND OPERATION	1
1. Description	1
1-1. General	1
2. Technical data	1
2-1. Characteristics	1
2-2. Overall dimensions	2
3. Description	2
4. Operation	3
4-1. Temperature	3
4-2. Maintenance	3
5. Charge	4
5-1. Constant Current Charge	4
5-2. Emergency Rapid Partial Charge	4
5-3. Other methods of charging	5
TESTING AND FAULT ISOLATION	1001
1. Introduction	1001
1-1. Battery electrical faults	1001
1-2. Cell faults	1002
1-3. Physical faults	1003
DISASSEMBLY	3001
1. Introduction	3001
2. Safety	3001

3. Equipment	3001
3-1. Standard tools	3001
3-2. Special tools	3001
4. Disassembly procedures	3001
4-1. Removing the cover (050)	3001
4-2. Removing the cells (320)	3001
4-3. Removing the vent valves (325)	3001
4-4. Removing the connector (200)	3001
4-5. Disassembly of the battery	3002

CLEANING -----4001

1. Introduction	4001
2. Safety	4001
3. Equipment	4001
3-1. Standard tools	4001
3-2. Special tools	4001
3-3. Consumables	4001
4. Light Cleaning	4001
4-1. Procedure	4001
5. Thorough Cleaning	4001
5-1. Procedure	4001
6. Lubrication	4002

INSPECTION/CHECK -----5001

1. Introduction	5001
1-1. General	5001
2. Maintenance intervals	5001
2-1. Periodical check	5001
2-2. Regular check	5001
2-3. General overhaul	5001
3. Recording	5001
4. Safety	5001
5. Equipment	5001
5-1. Standard tools	5001
5-2. Special tools	5001
6. Periodical check	5002
6-1. Visual Inspection	5003
6-2. Insulation check	5003
6-3. Nut tightness	5004
6-4. Polarization test	5004
6-5. Residual discharge	5004
6-6. Adjust electrolyte level	5004
6-7. Supplementary test	5005
7. Regular check	5006
7-1. Cell shorting	5007
7-2. Capacity check	5007
8. General overhaul	5008
8-1. Component inspection	5009
8-2. Replacement of faulty components	5009
8-3. Vent valve test	5009
9. Return to Service After Storage	5010

ASSEMBLY -----7001

1. Introduction	7001
2. Safety	7001
3. Equipment	7001
3-1. Standard tools	7001
3-2. Special tools	7001
4. Battery Assembly	7002
4-1. Installation of the liner spacer kit (130)	7002
4-2. Installation of the vent valve (325)	7003

4-3. Installation of the connector (200)	7003
4-4. Installation of the cells (320)	7003
4-5. Recording	7004

FITS AND CLEARANCES -----8001

1. Introduction	8001
2. Torque table	8001

SPECIAL TOOLS, FIXTURES, EQUIPMENT AND CONSUMABLES -----9001

1. Introduction	9001
2. Standard tools	9001
3. Special tools	9002
4. Consumables	9002

ILLUSTRATED PARTS LIST -----10001

1. Introduction	10001
1-1. General	10001
1-2. Numerical Index	10001
1-3. Detailed Parts List	10001
2. Alpha numerical index	10003
3. Detailed part list	10004

STORAGE (INCLUDING TRANSPORTATION) -----15001

1. Introduction	15001
1-1. General	15001
1-2. Storage room	15001
1-3. Temperature conditions	15001
2. Storage procedure	15001
2-1. Preparation of the battery before storage	15001
2-2. Packaging	15001
2-3. Short term storage	15001
2-4. Long term storage	15001
2-5. Servicing after discharged storage	15002
3. Transportation procedure	15002

PAGE INTENTIONALLY LEFT BLANK

LIST OF ILLUSTRATIONS

INTRO-1	Universal Recycling Symbols	INTRO-3
1	Overall dimensions	2
2	2758 Nickel-Cadmium Aircraft Battery	3
5001	Periodical check	5002
5002	Position of Syringe in Cell Vent Seat	5005
5003	Regular check	5006
5004	General overhaul	5008
7001	Liner spacer kit installation	7002
7002	Battery circuit	7003
10001	2758 Nickel-Cadmium Aircraft Battery	10004
15001	Short term storage	15001

PAGE INTENTIONALLY LEFT BLANK

INTRODUCTION

1. General

This manual provides the information necessary for an experienced shop technician to maintain Saft nickel-cadmium batteries. It describes construction of the battery, as well as techniques used to operate, maintain, repair, overhaul, and generally care for the battery. Following these instructions will enhance the ability to obtain optimum performance and maximum life from Saft batteries.

All aircraft batteries require checking and maintenance in order to make sure they are safe when installed and they perform their required functions especially in emergency conditions on board the aircraft. Maintenance checks also permit any problems to be identified and corrected. The maintenance interval is the period for which correct operation is assured with a low probability of failure and allows high levels of MTBUR and MTBF to be achieved. Apart from the question of safety, the avoidance of failure on board the aircraft, with consequent costly impact on delays, reduces operational costs.

Every effort has been made to provide complete and accurate instructions. If a situation should arise that is not adequately described in this manual, please contact Saft via the internet at www.saftbatteries.com or at one of the following addresses:

Saft America Inc. (V09052)
711 Industrial Boulevard
Valdosta, Georgia 31601 - USA
Tel: +1 (229) 247-2331
Fax: +1 (229) 247-8486

Saft (F6177)
12, rue Sadi Carnot
93170 Bagnole - France
Tel: +33 (0) 1 49 93 19 18
Fax: +33 (0) 1 49 93 19 56

2. Website

All Saft technical documentation, distributors and repair shops can be found at www.saftbatteries.com.

3. Definitions

Warnings call attention to use of materials, procedures, or limits, which must be followed precisely to avoid injury to persons.

Cautions call attention to procedures which must be followed to avoid damage to equipment.

Notes call attention to procedures which make the job easier.

4. Safety

Caution: Except for those steps that require the battery to be charged, do all steps on discharged batteries (refer to [Residual discharge](#) paragraph) to avoid the possibility of electric shock. Tighten vent-valves (325) prior to beginning discharge. Battery cells deliver very high current when short-circuited. Exercise caution. Remove rings, watches, necklaces, metallic belts or other jewelry to avoid electric shock.

Caution: Do not tilt the battery while doing maintenance, any contact of skin with electrolyte can cause severe burns.

Safety rules are different from one country to another. Always follow local safety regulations.

There are three types of risks.

4-1. Physical

- Handling: the battery is heavy. When you lift it, bend your legs and not your back.
- Use protective shoes.

4-2. Electrical

- Do not wear rings, watches, chains, belt buckles, necklaces or any other metallic objects.
- Use insulated tools.

4-3. Chemical

- For a complete listing of hazards, refer to the MSDS available on Saft's website at www.saftbatteries.com. Electrolyte is very corrosive and can damage the skin: use gloves and an apron. If it touches the skin, flush affected part with water and neutralize with an acetic solution, vinegar or lemon juice, or with a boric acid solution at 10% concentration.
- Electrolyte is very dangerous for eyes, use protective goggles. If the electrolyte comes in contact with the eyes, flush them with water for at least 15 minutes and immediately call a doctor.
- Electrolyte ingestion can cause damage to the throat and the respiratory tract. Do not try to vomit. Call a doctor immediately.
- Skin contact with nickel can cause chronic eczema.
- Inhalation of cadmium oxide can cause dry throat, headaches, vomiting, chest pain. If inhaled, remove to fresh air. If not breathing, give artificial respiration. If breathing is difficult, give oxygen. Get medical attention immediately.

- Potassium hydroxide in the electrolyte can cause eczema.

5. Aircraft Conversions

Saft aircraft batteries come in a wide variety of configurations that are approved for installation on selected aircraft. When replacing a lead-acid battery with a Saft nickel-cadmium aircraft battery, it is vitally important to clean all mounting and holding fixtures in the aircraft prior to installation. All traces of acid and salt should be removed by washing with a neutralizing agent such as sodium bicarbonate (baking soda) in water. Once the area has been fully cleaned and prepared, the surface should be painted with an alkaline resistant paint. This preparation should ensure that your new Saft battery will not be harmed by sulfuric acid residue.

6. Ground Applications

Your Saft battery can be used in such ground applications as starting gas turbine generators, ground mobile equipment, or in shop testing equipment. The same principles used in flight operations apply when the battery is used in ground applications. Ventilation of the battery during ground use can be accomplished through a ventilation system or by simply removing the cover (only in a well-ventilated area). Check with your local authorities for regulations in effect for your area.

7. Placing a new battery in service - initial commissioning

NOTE: Whether or not the battery has been subject to disassembly and reassembly, before its issue to service and installation, the tightness of all connector nuts / screws must be checked to verify that torque values correspond with those specified.

Saft batteries are shipped discharged. A visual inspection, torque check, charge procedure, electrolyte check, and insulation test should be done prior to the battery being placed into the aircraft for service. Refer to the [INSPECTION/CHECK](#) chapter. If the battery has been stored for longer than 3 months, refer to [Servicing after discharged storage](#)

8. Battery Ratings

8-1. Capacity

Nickel-cadmium batteries are rated in terms of capacity in ampere-hours (Ah) (rated capacity).

Capacity is the quantity of electricity, usually expressed as ampere-hours (Ah) available from a cell/battery. The rated capacity of aircraft batteries is defined according to international standards (EN2570, IEC 60952 and RTCA DO 293) under specific conditions for a fully charged battery.

A battery rated for 1C₁Ah indicates that the battery is rated at a value based upon a discharge time of 1 hour at 23°C ± 3°C (73.4°F ± 5.4°F).

9. Recycling

All batteries eventually lose their ability to perform and are eligible for scrap and recycling. Saft takes environmental matters seriously and advocates proper recycling of nickel-cadmium batteries and their components. To that end, Saft operates recycling facilities in both Europe and North America.

Nickel-cadmium batteries contain nickel, cadmium, and potassium hydroxide and should be disposed of properly. In all cases, rely on local and national regulations for proper battery disposal and/or shipping to an appropriate recycling location.

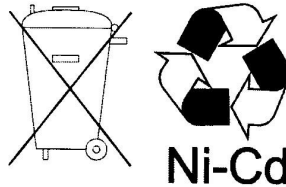

Figure INTRO-1 Universal Recycling Symbols

You can find the nearest recycling collection point on our website at www.saftbatteries.com.

10. End of life cells

EASA regulations 'Part 145', require that end of life cells must be disposed of in a manner that does not allow them to be returned to service. The following procedure provides a means of complying with these regulations.

While other authority requirements (such as FAA) may be less explicit, Saft recommends that the following procedures be adopted in order to ensure that end of life cells cannot be re-used:

- Ensure that appropriate protective measures (refer to [Safety](#) paragraph) and MSDS are taken.
- Ensure that the cell is fully discharged (refer to [Cell shorting](#) paragraph)
- Put one of the terminals from the cell between the two sides of a bench vice and bend until the terminal breaks. In the event of electrolyte leakage, ensure that appropriate clean up measures as described in the MSDS are observed.
- Dispose of the cell in accordance with applicable transport, health and safety and recycling regulations (Refer to [Recycling](#) paragraph).

11. Measurements

The measurements which are given in this manual come from the original manufacturer drawings.

This CMM uses the "Système International" (S.I.) units for quantities and values. It also gives the imperial units in parentheses.

11-1. Units of Measure

11-1-1. I.S. Units

A	Ampere
Ah	Ampere hours
C ₁ A	Rated current
C ₁ Ah	Rated capacity for an hour
g	Gram
min	Minute
N	Newton
N.m	Newton meter
Pa	Pascal
V _{DC}	Volt direct current
°C	Degree Celsius
%	Per cent
Ω	Ohm

11-1-2. U.S. Units

ft	Foot
in	Inch
inHg	Inch of mercury
lb	Pound
lbf.in	Pound force inch
°F	Degree Fahrenheit

11-1-3. Multiplying Prefixes

μ	Micro
m	Milli
da	Deca
k	Kilo
M	Mega

11-2. Measurement Conversion Table

11-2-1. From U.S. Standard System to I.S. Measurement

1 kPa	0.1450 psi
1 cm	0.3937 in
1 cm ²	0.1550 in ²
1 N	0.2248 lbf
1 g	0.0353 oz
1 kg	2.2046 lb
1 mm	0.0394 in
1 N.m	8.8507 lbf/in

11-2-2. From U.S. Standard System to I.S. Measurement

1 psi	6,8948 kPa
1 in	2,54 cm

1 in	25,4 mm
1 in ²	6,4516 cm ²
1 lbf	4,4482 N
1 oz	28,3495 g
1 inHg	3,3864 kPa
1 lb	0,4536 kg
1 gal (U.S.)	3,7854 l/min
1 lbf.in	0,1130 N.m
1 lbf.ft	1,3558 N.m

11-3. Temperature Conversion Table

11-3-1. SI MEASUREMENT Degrees Celsius (°C)

Celsius = (Fahrenheit - 32) x 0.5555

11-3-2. U.S. STANDARD SYSTEM Degrees Fahrenheit (°F)

Fahrenheit = (Celsius x 1.8) + 32

11-4. Abbreviations

The abbreviations given below are used in this manual:

AECMA	European Association of Aerospace Industries
ATA	Air Transport Association of America
dia.	diameter
EASA	European Air Safety Authority
FAA	Federal Aviation Authority
fig.	figure
ipl	illustrated parts list
max.	maximum
mfr	manufacturer
min.	minimum
MTBF	Mean time between failure
MTBUR	Mean time between unscheduled removal
n°	number
p/n	part number
para.	paragraph
ref.	refer to
s/a	subassembly
TBD	to be defined
V	Voltage

PAGE INTENTIONALLY LEFT BLANK

DESCRIPTION AND OPERATION**1. Description****1-1. General**

The batteries are connected to the aircraft system:

- According to the aircraft manufacturer, to start the engine or the APU.
- On the ground, to provide power before electrical power is supplied to the aircraft systems.
- In flight, if a malfunction or a failure occurs in the power supply system

2. Technical data**2-1. Characteristics**

The most important characteristics are indicated in the table below.

Technical data	Values
Type of cells	VHP230KA-3
Number of cells	20
Nominal voltage	24 V
Rated capacity C ₁ Ah (Ah)	23 Ah
Charge or discharge current 1 C ₁ A	23 A
Charge current 0.5 C ₁ A	11.5 A
Charge current 0.1 C ₁ A	2.3 A
Electrolyte	Solution of KOH
Electrolyte level (mm)	20 mm (0.79 in)
Consumable volume of electrolyte per cell	60 cm ³ (3.66 in ³)
End of charge voltage	1.5 V / per cell
End of life criteria in %	100%
End of life criteria in hour or minutes	1 hour
Battery maximum weight	25.5 kg (56.2 lbs)
Battery terminals	Connector according to ISO 5064/11 or MS 3509

2-2. Overall dimensions

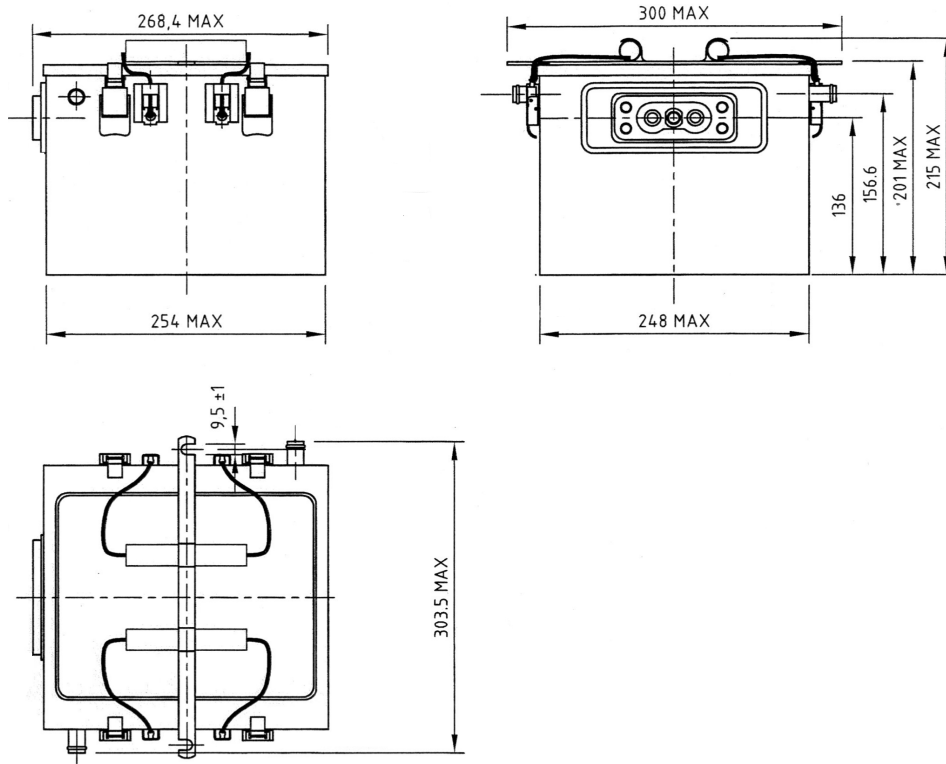

Figure 1 Overall dimensions

3. Description

NOTE: The item numbers are those of the detailed parts list chapter.

The [2758](#) Saft nickel-cadmium battery consists of a stainless steel box ([020](#)), containing [20](#) individual cells [VHP230KA-3](#). These cells are connected in series to obtain [24 V](#) nominal. Individual cells are enclosed in a container that provides insulation, allowing them to be fitted side-by-side in the battery box. Interconnection of cells is via rigid, highly conductive, nickel-plated copper links ([270](#) to [310](#)). Each link is held in place by nickel-plated copper nuts ([350](#)) on the cells' terminals. Inside the battery box, individual cells are held in place by partitions, liners and spacers ([130](#)), and a cover complete ([050](#)).

The connector ([200](#)) connects the battery to the aircraft DC power.

The cover (050), which can be removed, is attached to the box (020) by four latches.

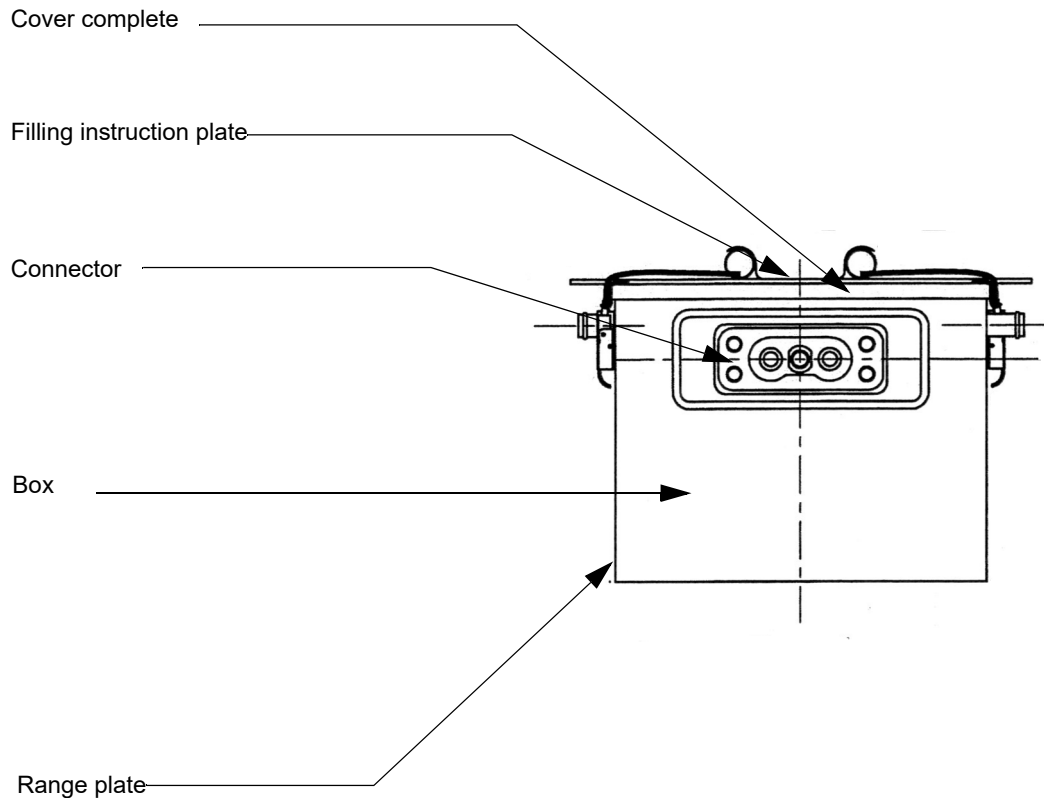

Figure 2 [2758](#) Nickel-Cadmium Aircraft Battery

4. Operation

4-1. Temperature

Although Saft nickel-cadmium batteries are capable of operating in a wide temperature range [-40°C (-40°F) to +71°C (+160°F)], optimum performance is obtained between +5°C (+41°F) and +45°C(+113°F). Charging is inefficient at temperatures below -30°C (-22°F) and is not recommended above 57°C (135°F). Charging must be stopped at temperatures above +71°C (+160°F).

Unless otherwise stated, charge and discharge testing should be done when the battery temperature is between +15°C and +30°C.

4-2. Maintenance

All maintenance, including charging, discharging, should be done specifically in accordance with the instructions contained in this manual.

5. Charge

5-1. Constant Current Charge

Starting with a discharged battery.

- Remove the cover complete (050).
- Loosen, but do not remove, all vent-valves (325).
- Charge using one of the methods shown in the table below.

NOTE: Check cell voltage at the beginning of the charge. If any cell indicates an immediate voltage rise above 1.5 V, add 5 cm³ of distilled or deionized water to that cell.

- During the last 15-30 minutes of the overcharge cycle, [Adjust electrolyte level](#).

Main charge			Final charge (overcharge)	
Current	Criteria of end of charge		Current and duration	Minimum voltage at the end of charge
	Time	voltage		
2.3 A	mini 10 h maxi 12 h	mini: 30 V maxi: 34 V	2.3 A for 4 h	1.5 V / per cell
11.5 A	mini 2 h maxi 2 h 30 min.	mini: 31 V maxi: 34 V	2.3 A for 4 h	1.5 V / per cell
23 A	mini 1 h maxi 1 h 15 min.	mini: 31.4 V maxi: 34 V	2.3 A for 4 h	1.5 V / per cell

Table 1 - Charge Rates

5-2. Emergency Rapid Partial Charge

One of the following procedures can be used in an emergency situation to partially charge the battery. **Do not use these procedures for charging the battery during normal maintenance.**

NOTE: A maintenance check of the battery should be done at the earliest opportunity to verify battery performance.

5-2-1. Constant current

To obtain approximately 80% of the rated capacity of the battery:

- Charge the battery at [11.5 A](#) until the battery reaches an average of 31 V and stop the charge. Do not charge for more than 2 hours and 30 minutes

or

- Charge the battery at [23 A](#) until the battery reaches an average voltage of 31.4 V and stop the charge. Do not charge for more than 1 hour and 15 minutes.

5-2-2. Constant voltage

Caution: Constant voltage charging should not be attempted if the open circuit battery voltage is below 1.0 V per cell.

With the use of a constant voltage charging system (ground charger or aircraft system), it is imperative that the charge rate be checked periodically for accuracy, and that the charger be set according to the average ambient operating temperature.

Connect the battery to the constant potential power source. Charge for a minimum of 1 hour at 1.425 V/cell to obtain approximately 90% of the rated capacity of the battery

5-3. Other methods of charging

In addition to the constant current method of charging, other methods that fully charge the battery can be used. However, in any case, cell voltage checks ($U > 1.5 \text{ V / per cell}$) and electrolyte adjustments must be carried out using a final overcharge sequence at constant current [2.3 A](#) during 4 hours. If specific instructions are not given in the charger operating manual, you must first contact Saft.

TESTING AND FAULT ISOLATION

1. Introduction

This chapter gives the tests and inspections required to find the cause of a fault condition of the unit either removed for un-scheduled maintenance or during scheduled maintenance. The test procedure is given in the tables below. For each test refer to the indicated procedures which specify all necessary information.

1-1. Battery electrical faults

Problem	Probable cause	Correction
(1) Zero volt battery open-circuit voltage	(a) Defective electrical connector (no contact made) (b) Link broken	Check electrical contacts, links and tightness of nuts (refer to INSPECTION/CHECK).
(2) Zero volt with the battery set to "discharge"	(a) Battery fully discharged (b) Battery circuit open or contacts defective (c) Cell completely dry	Do an insulation check (refer to Insulation check). Charge the battery (refer to Charge). Examine the contacts and links. Make sure the terminal nuts are tight (refer to INSPECTION/CHECK). Refer to related subsequent steps. Replace the cell.
(3) Low insulation	(a) Leakage of electrolyte	Disassemble and clean the battery (refer to DISASSEMBLY and CLEANING). Do an electrolyte level check (refer to INSPECTION/CHECK).

Table 1 - Battery electrical faults

1-2. Cell faults

Problem	Probable cause	Correction
(1) Too much water decrease for all battery cells.	(a) Charge much more than the limit or too much charge at high temperature.	Examine the cause of excessive charge. If necessary, adjust to normal operating temperature (refer to Description and operation).
(2) Water decrease in cell(s) is very different from the other cells in the battery.	(a) More than 30% or more than the average : cell leakage.	Check for cell leakage (refer to INSPECTION/CHECK)
	(b) 30% (or less) of the average: cell(s) with damaged separator(s).	Do the Supplementary test (refer to INSPECTION/CHECK). If necessary, replace the cell(s).
	(c) Previous maintenance has not been done.	Note the cell location and check the level of water consumption versus other cells at the next maintenance.
(3) A cell has a higher voltage at the start of charge than is defined in para. Charge chapter Description and operation .	(a) Dry cell.	When the defect occurs, add 5 cm ³ (5 ml) of distilled water to the cell. Do not adjust more accurately until the end of the charge.
NOTE: If you charge a cell with a quantity of electrolyte which is not sufficient, this can cause the temperature to increase too much.		
(4) A cell has a lower voltage at the end of charge than is defined in para. Charge chapter Description and operation .	(a) The cell was operated at temperatures and charge rates outside the limits, and the separator is damaged.	Do the Supplementary test (refer to INSPECTION/CHECK). Replace the cell (refer to DISASSEMBLY, ASSEMBLY AND Storage (including transportation)).
	(b) Usual wear after long operation	
(5) Low capacity cell.	(a) insufficient balancing	Do the Supplementary test (refer to INSPECTION/CHECK). Repeat Charge , discharge at 23 A and Cell shorting up to three times.
	(b) Usual wear after long operation.	Replace the cell (refer to DISASSEMBLY, ASSEMBLY AND Storage (including transportation)).
	(c) Unusual operation, operation at high temperature or operation with low electrolyte.	Do the applicable procedure (refer to INSPECTION/CHECK).
(6) Cell with a swollen case.	(a) Cell operated with low electrolyte level ; deterioration of separators and damaged plates.	Replace the cell (refer to DISASSEMBLY).
(7) Cell with zero voltage when the battery circuit is open.	(a) Short-circuited cell.	Replace the cell (refer to DISASSEMBLY).

Table 2 - Cell faults

1-3. Physical faults

Problem	Probable cause	Correction
(1) Leakage of electrolyte.	<p>(a) Incorrect adjustment of electrolyte level.</p> <p>(b) Cell polarity incorrect during high-rate discharge (for example, during the engine start).</p> <p>(c) Too much charge at high temperature or too much current.</p> <p>(d) The lower nut is not correctly tightened.</p>	<p>Disassemble and clean the battery (refer to DISASSEMBLY and CLEANING chapters). Do an electrolyte level check (refer to INSPECTION/CHECK).</p> <p>Disassemble and clean the battery (refer to DISASSEMBLY and CLEANING). Do an electrolyte level check (refer to INSPECTION/CHECK). Investigate the cause of excessive charge. If necessary, adjust to normal operating temperature (refer to Description and operation).</p> <p>Disassemble and clean the battery (refer to DISASSEMBLY and CLEANING). Do an electrolyte level check (refer to INSPECTION/CHECK).</p> <p>Torque the lower nut (refer to ASSEMBLY chapter)</p>
(2) Electrolyte found in the battery box.	<p>(a) Damaged cell case.</p> <p>(b) Leakage of electrolyte.</p>	<p>Do a leak test of the cells (refer to INSPECTION/CHECK).</p> <p>Replace the cell if necessary and refer to related subsequent steps.</p> <p>Disassemble and clean the battery (refer to INSPECTION/CHECK and CLEANING).</p> <p>Do an electrolyte level check (refer to INSPECTION/CHECK).</p>
(3) Corrosion on the links.	<p>(a) Operation in acidic air.</p> <p>(b) Mechanical damage to nickel plating.</p>	<p>Make sure the battery test bench and the storage areas have no materials which can give off acid fumes.</p> <p>Replace the damaged links (refer to DISASSEMBLY, ASSEMBLY AND Storage (including transportation)).</p>
(4) The links are too hot.	<p>(a) Loose terminals nuts.</p>	<p>Make sure the nuts are torqued (refer to INSPECTION/CHECK).</p>

Table 3 - Physical faults

PAGE INTENTIONALLY LEFT BLANK

DISASSEMBLY

1. Introduction

NOTE: Refer to the [Testing and fault isolation](#) chapter to identify the possible cause of a malfunction. This will give the necessary level of disassembly.

The instructions found in this section are designed to allow the maintenance person to completely disassemble the battery for the purpose of General Overhaul. However, some maintenance operations do not require complete disassembly. Disassemble only to the extent necessary to effect appropriate repair or replacement.

2. Safety

Refer to chapter [Standard tools](#) in [SPECIAL TOOLS, FIXTURES, EQUIPMENT AND CONSUMABLES](#).

3. Equipment

3-1. Standard tools

Refer to chapter [Standard tools](#) in [SPECIAL TOOLS, FIXTURES, EQUIPMENT AND CONSUMABLES](#).

3-2. Special tools

When special tools are used in this chapter, they are identified by a code number listed in [SPECIAL TOOLS, FIXTURES, EQUIPMENT AND CONSUMABLES](#) chapter.

4. Disassembly procedures

NOTE: All () part identification numbers herein are IPL Fig. 1 item numbers and are using hypertext facility.

4-1. Removing the cover (050)

Undo the retaining latches. Remove the cover taking care to avoid contact between the cover and the cell terminals or links.

4-2. Removing the cells (320)

NOTE: Make note of the proper placement of the links (270 to 310) prior to removal.
To facilitate ease of removal, remove the center cell in each row first.

Remove the nuts (350) and the spring washers (360) that attaches links to the cells.

Remove the nuts (250) and the spring washers (260) that attaches links to the connector.

Remove all links (270 to 310).

Fully screw the extractor tool (T04) onto a cell terminal then pull up to remove the cells (320).

4-3. Removing the vent valves (325)

Unscrew the vent valve with the special tool (T01).

Remove the vent valve (325) with its O-ring.

4-4. Removing the connector (200)

Remove the screws (210) and the washers (220).

Remove the connector (200).

4-5. Disassembly of the battery

Remove the cover ([050](#)).

Remove the cells ([320](#)).

Remove the liner spacer kit ([130](#)). Note placement prior to removal to ensure proper placement during re-assembly.

Remove the connector ([200](#)).

CLEANING

1. Introduction

The instructions in this chapter are for the general cleaning of your Saft aircraft battery. The instructions under "Light Cleaning" are to be done each time the battery is removed from the aircraft, and can be accomplished with no disassembly of the battery. The section "Thorough Cleaning" includes the instructions for the cleaning of a disassembled battery for the purpose of a General Overhaul.

2. Safety

Refer to chapter [Standard tools](#) in [SPECIAL TOOLS, FIXTURES, EQUIPMENT AND CONSUMABLES](#).

3. Equipment

3-1. Standard tools

Refer to chapter [Standard tools](#) in [SPECIAL TOOLS, FIXTURES, EQUIPMENT AND CONSUMABLES](#).

3-2. Special tools

When special tools are used in this chapter, they are identified by a code number listed in [SPECIAL TOOLS, FIXTURES, EQUIPMENT AND CONSUMABLES](#) chapter.

3-3. Consumables

When consumables are used in this chapter, they are identified by a code number listed in [SPECIAL TOOLS, FIXTURES, EQUIPMENT AND CONSUMABLES](#) chapter.

4. Light Cleaning

On an assembled battery.

Caution: Do not use solvent, petroleum spirits, trichloroethylene or other products containing chloride for cleaning the battery. The use of solvents may degrade the integrity of metal and plastic parts.

NOTE: All () part identification numbers herein are IPL Fig. 1 item numbers.

4-1. Procedure

Caution: To prevent injury when using compressed air, direct air stream away from the body. Use safety goggles to prevent eye injury from airborne particles.

- Remove the battery cover complete (050).
- Check the battery vent tubes to ensure that they are clean and clear.
- Hand tighten the vent valves (325) with the Universal vent wrench (T01)
- Remove potassium carbonates (white deposits) from the top of all cells (320) using a stiff bristle, non-metallic brush.
- Disperse residual salts and dust particles from the battery using blasts of clean, dry compressed air.
- Coat all nuts (350) and links (270 to 310) with M02.

5. Thorough Cleaning

On a disassembled battery.

5-1. Procedure

Fully disassemble the battery (refer to [DISASSEMBLY](#) chapter).

5-1-1. Cells (320)

Make sure that the vent valve (325) is tight.

Caution: Do not soak the cells in water.

To easily remove all the electrolyte and mineral salts from the terminals, the cover and the sides of the cell cases: clean in warm water with a soft brush.

Rub the cell with a cloth and let dry.

5-1-2. Box and cover (010) and handle (030 and 040)

Clean with lightly soapy water, rub with a cloth and let dry.

5-1-3. Nuts, spring washers and links

Clean in lightly soapy water with a brush, rinse well with clean water and let dry.

5-1-4. Liner spacer kit ([130](#))

Clean in warm water and let dry.

5-1-5. Vent valve ([325](#))

Caution: The cleaning of the vent valve ([325](#)) must be done when the cells are assembled in the box.

Remove the vent valve ([325](#)) (Refer to [DISASSEMBLY](#) chapter).

Cover the cell holes to keep out unwanted material.

Soak the vent valve for some time (during the night, for example) in a container of distilled water to remove all salts from the vent hole.

6. Lubrication

When the battery is clean (and after installation of the vent valve), coat all upper nuts ([250](#)) and links ([270](#) to [310](#)) with [M02](#).

INSPECTION/CHECK

1. Introduction

1-1. General

This chapter includes the checks, the maintenance procedures and the functional tests that must be done to use Saft batteries in flight and on the ground.

NOTE: All () part identification numbers herein are IPL Fig. 1 item numbers.

2. Maintenance intervals

The aircraft manufacturer is responsible for defining the usage and function for aircraft batteries installed in its aircraft.

NOTE: Maintenance steps must be completed in a battery shop.

Saft distinguishes between three types of maintenance

2-1. Periodical check

The periodical check consists essentially of voltage and insulation checks, discharge of residual capacity and charge with electrolyte level adjustment. The main purpose of this periodical check is to replace water which is consumed by electrolysis during battery overcharge. It is normally applied between regular checks but can be omitted if the water consumption measured at the regular check is within allowable limits.

2-2. Regular check

The regular check is the same as the periodical check except that the battery is also deep discharged ('balancing'), followed by a capacity check cycle.

2-3. General overhaul

The general overhaul is the same as the regular check except that the battery is also disassembled and thoroughly cleaned and inspected.

3. Recording

It is very important to record the battery check values (capacity, end of charge voltage, water consumption) as required in the battery logbook for each maintenance. It is recommended that an operator tracks these maintenance data in order to verify the interval is correct relative to that particular operation. These data may also allow the interval to be extended, with the agreement of the competent authorities, if the data justify it .

4. Safety

Refer to chapter [Standard tools](#) in [SPECIAL TOOLS, FIXTURES, EQUIPMENT AND CONSUMABLES](#).

5. Equipment

5-1. Standard tools

Refer to chapter [Standard tools](#) in [SPECIAL TOOLS, FIXTURES, EQUIPMENT AND CONSUMABLES](#).

5-2. Special tools

When special tools are used in this chapter, they are identified by a code number listed in [SPECIAL TOOLS, FIXTURES, EQUIPMENT AND CONSUMABLES](#) chapter.

6. Periodical check

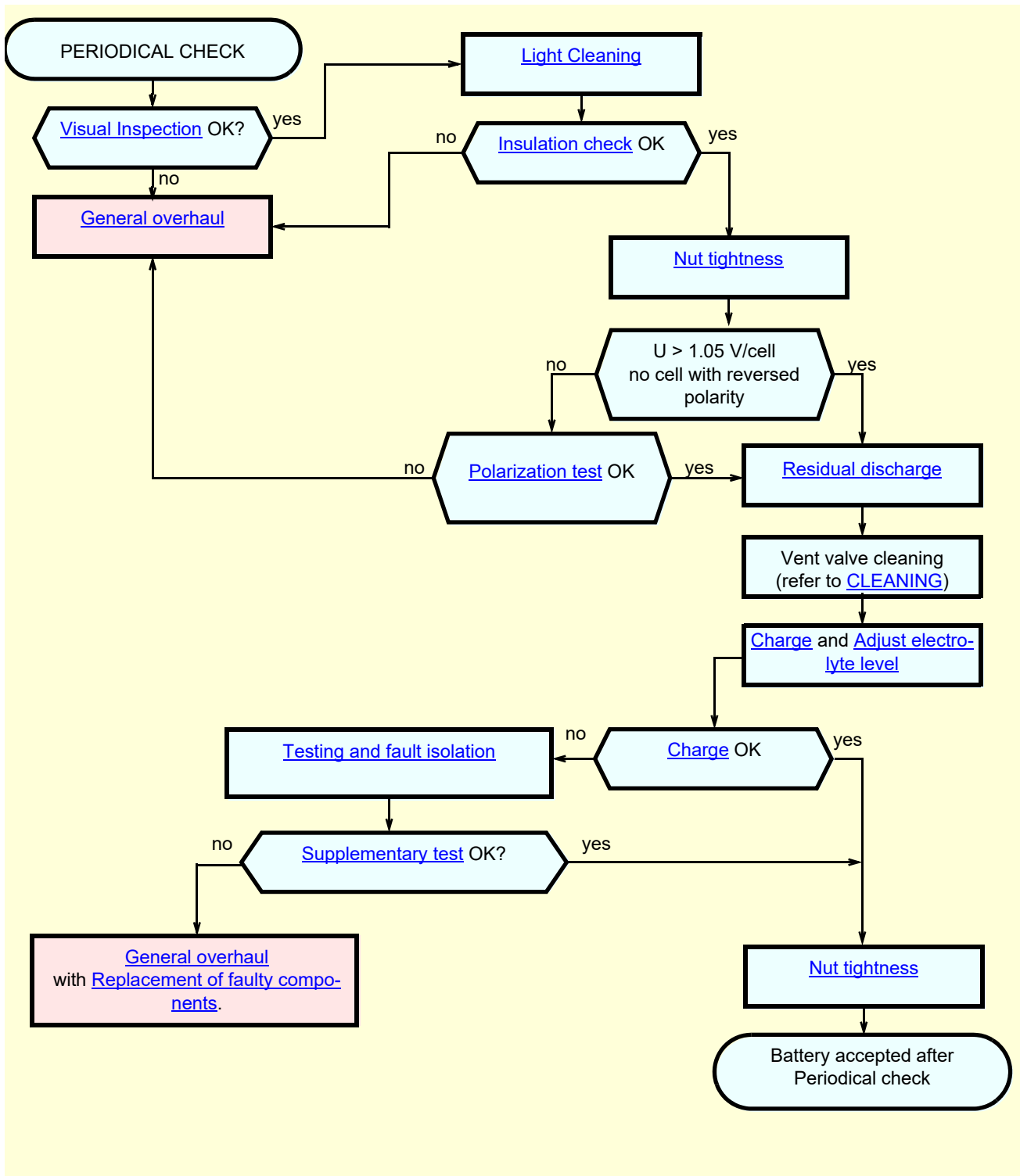

Figure 5001 Periodical check

Consult the airframe manufacturer for specific maintenance intervals or special procedures to be followed. Otherwise, at specific intervals according to aircraft use, or if electrolyte consumption exceeds the approved consumption levels between 2 regular checks, do this periodical check according to the above figure.

NOTE: Time periods are given as a guideline. Modify in accordance with operational experience. Periodic and Regular maintenance checks may be combined if operating hours permit.

NOTE: Whether or not the battery has been subject to disassembly and reassembly, before its issue to service and installation, the tightness of all connector nuts / screws must be checked to verify that torque values corre-

spend with those specified.

6-1. Visual Inspection

Visual inspection should be done each time the battery is removed for maintenance.

- Remove the cover complete (050).
- Visually check each cell (320) for any evidence of electrolyte leakage. If there is salt or electrolyte traces do a [General overhaul](#). Excessive salts around a terminal post indicates possible leakage from the terminal O-ring. Verify the torque of the lower nut (refer to chapter [ASSEMBLY](#)).
- Inspect the links (270 to 310) and all upper nuts (250), and washers (360 and 380). The hardware should be free of bends, tarnish, corrosion, burns, or any loss of nickel plating. Minor tarnish can be polished off with a fine wire brush. Defective hardware should be replaced.
- Check the connector (200) for evidence of arcing, corrosion, cracks, or cross-threaded terminals. Replace the defective connector.

Caution: Worn aircraft connectors and/or loose connections can greatly affect the performance of the battery. A defective connector (200) can cause battery self-discharge as well as low voltage in service.

- Inspect the electrical connector for bent or loose pins, corrosion, cracks, faulty wire connections, evidence of arcing, or cracked or loose potting material.
- Inspect the battery box (020) and cover assembly (050) for any damage. Minor dents may be repaired with a small rubber mallet. Ensure the cover gasket (070), if applicable, is undamaged and fully secured to the cover assembly (060).

6-2. Insulation check

A breakdown in electrical insulation between the cells (320) and the battery box (020) will result in a "leakage" current, which over time will discharge the battery. The most common cause for the loss of insulation is the leakage of electrolyte from the cells (320) that acts as a conductor between the cells and the battery box (020). Because leakage current can affect battery performance, it is necessary that it be kept to a minimum.

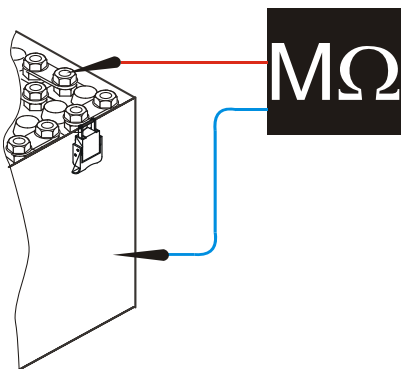

On a completely assembled battery, use a megohmmeter, set to 250 V DC, to measure the insulation resistance between the positive terminal of each cell (320) and the battery box (020).

Refer to the table below for the acceptance criteria.

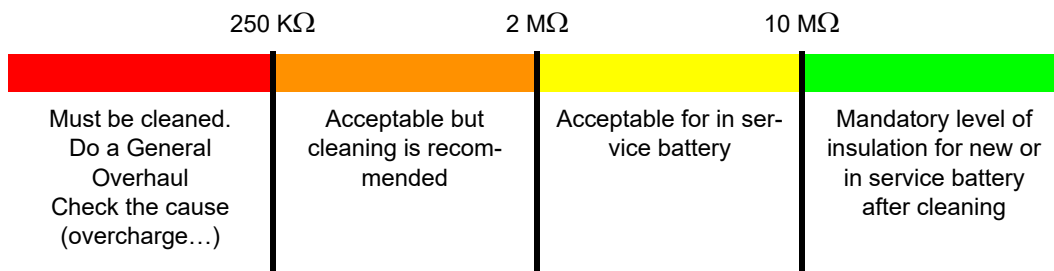

6-3. Nut tightness

Tighten and check the torque of all upper cell nuts ([350](#)) (refer to [FITS AND CLEARANCES](#)).

Tighten and check the torque of all upper cell nuts ([250](#)) (refer to [FITS AND CLEARANCES](#)).

6-4. Polarization test

Charge the battery at [2.3 A](#) for 1.5 hours.

Keep the battery in open circuit for 1 hour.

Measure the open circuit voltage of each cell. If any cell is zero (0) V or negative polarity, do a [General overhaul](#). If all cells are above zero (0) V, continue with maintenance as specified.

6-5. Residual discharge

Discharge the battery at the [23 A](#) or [11.5 A](#) rate until each cell in the battery is discharged to 1.0 volt or below.

6-6. Adjust electrolyte level

Caution: Using anything other than distilled or deionized water in nickel-cadmium cells will cause electrolyte contamination and damage.

Always take appropriate precautions to prevent any foreign substances from entering the cell. Anything other than distilled or deionized water that enters the cells will cause electrolyte contamination and will affect overall performance.

The amount of time that the vent-valves are removed from the cell for maintenance should be limited to prevent as much air as possible from entering the cell. Carbon dioxide in the air will combine with the electrolyte to form potassium carbonate. Potassium carbonate will increase the internal resistance of the cells and thus decrease the performance at low temperatures and during high rate discharges. Always ensure that the vent-valves are properly secured while the battery is in use.

Electrolyte level adjustment is to be done during the last 15-30 minutes of the 4 hours overcharge at [2.3 A](#) rate of charge.

Caution: Take care not to tilt cells while vent-valves are loosened or removed. Contact of electrolyte with skin can cause burns. If contact occurs, flush area with large amounts of water. Electrolyte in the eyes is very serious. Flush with water and contact a doctor immediately.

Caution: The battery must be fully charged before adjusting the electrolyte level.

Use only distilled or deionized water (see chapter [SPECIAL TOOLS, FIXTURES, EQUIPMENT AND CONSUMABLES](#)).

Do not re-use water removed from cells.

The quantity (in cm^3) required to level the first cell will serve as a guide for requirements of the remaining cells but the amount of water required for each cell can vary, so carry out this check on a cell by cell basis. Each cell must be leveled individually. If the quantity of water added per cell is above 80% of the electrolyte water volume shown in the specification tables (60 cm^3 (3.66 in^3)), check the charging system. If it is functioning properly, shorten the time period between servicing. In no case must the water consumption exceed 60 cm^3 (3.66 in^3).

Adjust the level of electrolyte, one cell at a time, using the following instructions:

- 1. Remove the vent-valves ([325](#)) with the vent-valve wrench ([T01](#))
- 2. Check the nozzle length at 20 mm before fitting it to the syringe

- 3. Insert the syringe (T02) into the cell opening until the shoulder of the nozzle rests on the vent-valve seat .

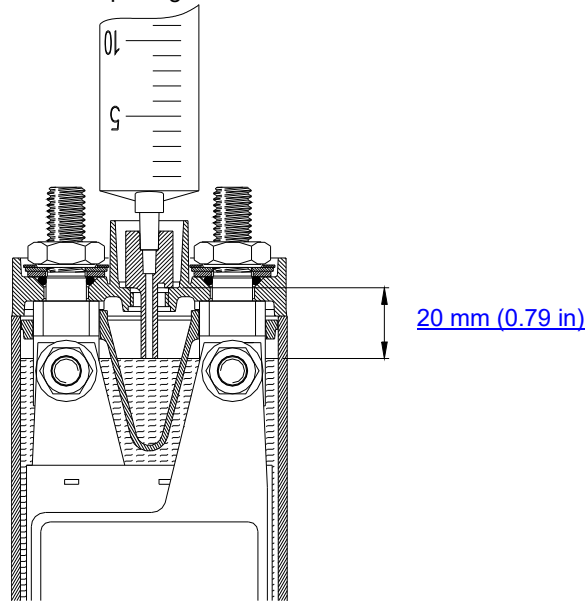

Figure 5002 Position of Syringe in Cell Vent Seat

- 4. Withdraw the plunger and check for any liquid in the syringe.
Any excess liquid in the cell will be drawn into the syringe until the electrolyte is level with the end of the nozzle. This is the correct level for the electrolyte.
If the liquid level is too low, the syringe will remain empty, indicating that the end of the syringe nozzle did not reach the liquid in the cell. In this case, replenish low electrolyte:.
- 5. Draw 5 cm³ of the distilled water (M01) into the syringe and inject it into the cell.
- 6. With the syringe nozzle remaining on the vent-valve (325) seat, slowly withdraw the plunger in the syringe.
- 7. If the syringe remains empty, repeat steps 5 and 6, counting the number of 5 cm³ injections required to achieve the correct level. Record the amount of water added to each cell on the maintenance record.
- 8. At the point in step 6 when some excess liquid is drawn into the syringe, the correct level for that cell has been reached. Expel the excess liquid into a separate container for disposal. Do not re-use the liquid removed from cells. Check with local authorities for proper disposal of hazardous waste.

6-7. Supplementary test

At the end of complete charge, continue to charge for 5 h at [2.3 A](#)

Measure the voltage of the individual cell voltages every 30 min. The individual cell voltages:

- must not decrease by more than 0.03 V during the test
- must be more than [1.5 V / per cell](#)
- Adjust the electrolyte level (refer to [Adjust electrolyte level](#)).

7. Regular check

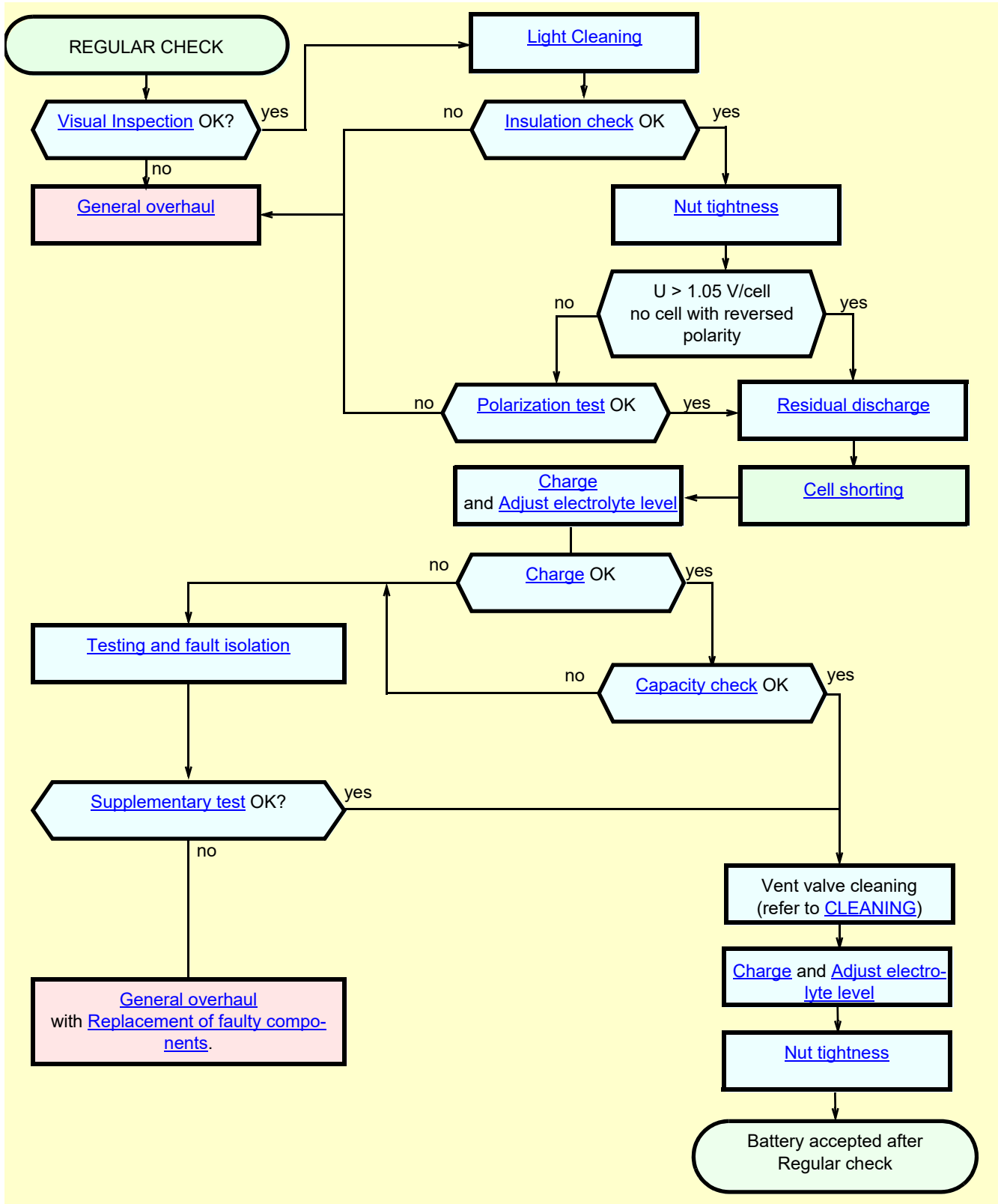

Figure 5003 Regular check

Consult the airframe manufacturer for specific maintenance intervals or special procedures to be followed. Otherwise, at specific intervals according to aircraft use, or AFTER A MAXIMUM OF ONE YEAR of operation, test the battery according to the above figure.

NOTE: Time periods are given as a guideline. Modify in accordance with operational experience. Periodic and Regular maintenance checks may be combined if operating hours permits.

NOTE: Whether or not the battery has been subject to disassembly and reassembly, before its issue to service and installation, the tightness of all connector nuts / screws must be checked to verify that torque values correspond with those specified.

7-1. Cell shorting

As each cell's voltage drops below 1.0 V, connect an equalizing resistor ([T03](#)) across each cell's terminals. Leave the resistors in place for 12 to 16 hours to allow each cell to completely discharge and the battery to cool.

NOTE: As an alternative to the resistor a shorting clip can be applied when the voltage has dropped to 0.5 V/cell.

7-2. Capacity check

Discharge the battery at [23 A](#). Record the time when the first cell reaches 1.0 volt. This time must be equal or greater to [1 hour](#).

8. General overhaul

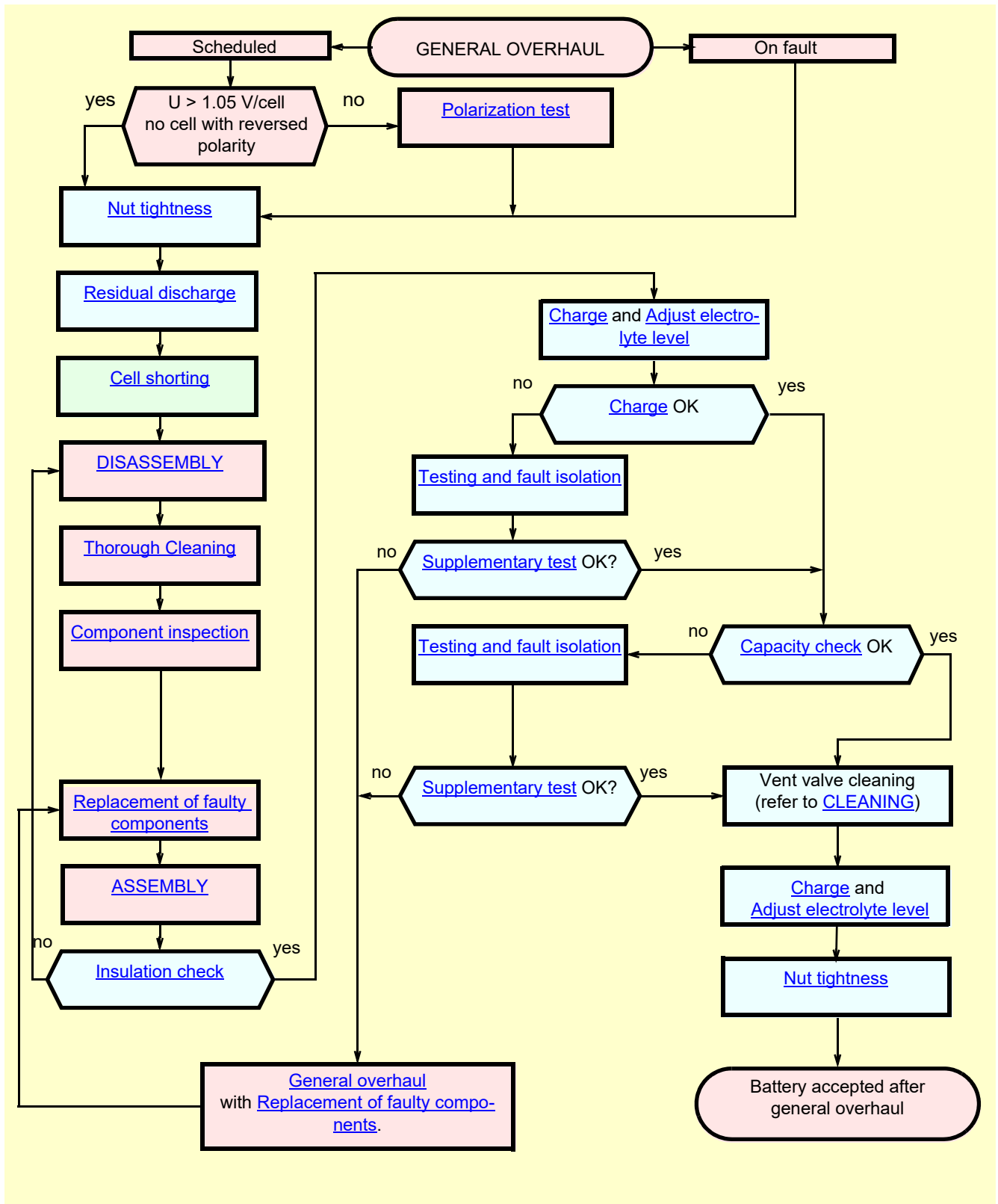

Figure 5004 General overhaul

Consult the airframe manufacturer for specific maintenance intervals or special procedures to be followed. Otherwise, at specific intervals according to aircraft use, or AFTER A MAXIMUM OF ONE YEAR of operation, test the battery according to the above figure.

NOTE: Whether or not the battery has been subject to disassembly and reassembly, before its issue to service and installation, the tightness of all connector nuts / screws must be checked to verify that torque values correspond with those specified.

8-1. Component inspection

8-1-1. Cells

Make sure that the lower terminal nuts are tight (refer to [FITS AND CLEARANCES](#) chapter).
Verify that cell boxes show no leakage.

8-1-2. Box

Make the sides of the box straight and remove dents.

8-1-3. Nuts, links and spring washers

Discard the components that show signs of corrosion or damage.

8-1-4. Packing parts

Discard all defective components.

8-1-5. Connector

Check the connector ([200](#)) for evidence of arcing, corrosion, cracks, or cross-threaded terminals. Replace the defective connector.

8-2. Replacement of faulty components

8-2-1. Cells - 3/5 cells rule

Saft strongly recommends to change all the cells or replace the complete battery if:

- **One or more cells are found to be faulty and 5 of the original cells in the battery have been previously changed during the previous maintenance**

or

- **Three (3) or more cells are found to be faulty during the same maintenance.**

The 3/5 cells rule does not apply to the following failures:

- Mechanical failure such as terminal thread damage
- Cell leakage
- Cell short-circuit

All cells to be replaced must be replaced by new Saft cell assembly ([320](#))

8-2-2. Other components

Any other components that are to be replaced must be replaced by new Saft components

8-3. Vent valve test

NOTE: The Vent Valve Test is not necessary if the full set of used vent valves is replaced by a brand new one each year during the General Overhaul or when there is evidence of electrolyte overflow.

- This test should be done while the battery is on charge, just following the electrolyte leveling procedure. Check the operation of the vent-valve assembly as follows: Place the vent valve ([325](#)) with its O-ring into the vent valve adapter ([T05](#)) of the pressure test fixture.
- Immerse the vent-valve in water and slowly raise the air pressure.
- Test according to the table below, and change all vent valves if they do not pass the test.

test	Check
O-ring	No distortion, split or cracks
air pressure < 0.14 bar (2 psi)	Vent valve is closed
0.14 bar (2 psi) < air pressure < 0.7 bar (10 psi)	Vent valve opens

Table 1 - Vent valve test

9. Return to Service After Storage

When a battery is to be returned to service after storage, procedures should be followed as given in chapter [Storage \(including transportation\)](#).

ASSEMBLY

1. Introduction

This section covers basic battery assembly procedures. In all cases, when reassembling a battery, all components should be clean and dry.

2. Safety

Refer to chapter [Standard tools](#) in [SPECIAL TOOLS, FIXTURES, EQUIPMENT AND CONSUMABLES](#).

3. Equipment

3-1. Standard tools

Refer to chapter [Standard tools](#) in [SPECIAL TOOLS, FIXTURES, EQUIPMENT AND CONSUMABLES](#).

3-2. Special tools

When special tools are used in this chapter, they are identified by a code number listed in [SPECIAL TOOLS, FIXTURES, EQUIPMENT AND CONSUMABLES](#) chapter.

4. Battery Assembly

NOTE: All () part identification numbers herein are IPL Fig. 1 item numbers.

4-1. Installation of the liner spacer kit (130)

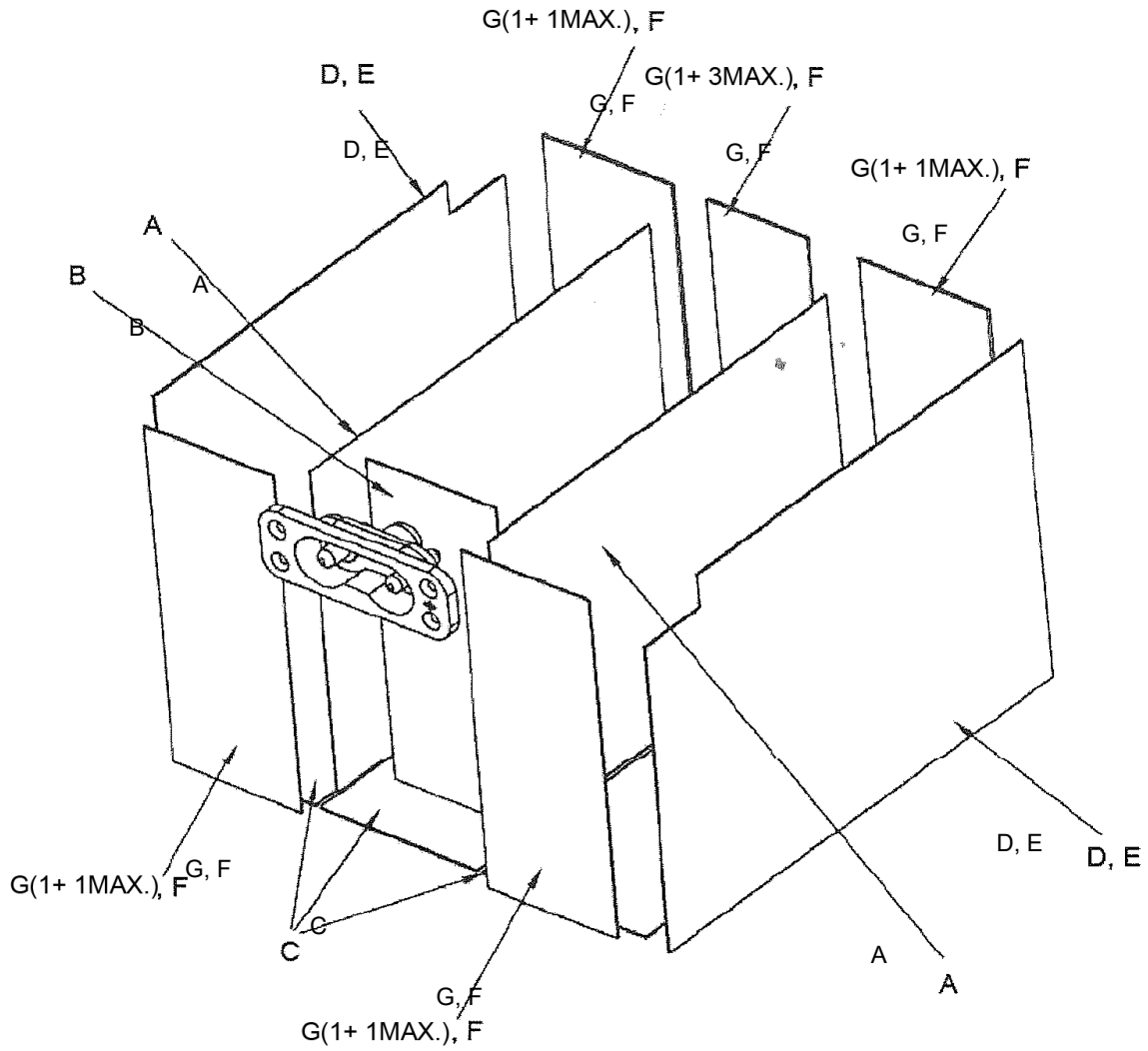

Figure 7001 Liner spacer kit installation

NOTE: You must assemble the D and E slotted spacers to keep the ventilating system of the box free.

NOTE: only the spacers F is mandatory, the spacers G are installed in order to adjust the fitting of the cells.

- Put the different spacers in position (Ref. fig.7001).
- Install the cells.

Item	Description	Dimension (mm)	Unit per assembly
A	Spacer	0.3x236x160	2
B	Spacer	1x160x75	1
C	Spacer	0.3x248x243	1
D	Spacer	0.5x245x167	4
E	Spacer	1x245x167	2
F	Spacer	3x167x78	5
G	Spacer	1x167x78	5

4-2. Installation of the vent valve (325)

Make sure the vent valves (325) are in good condition. Replace the vent valves (325) if they are worn.

Install the vent valve (325) with the universal vent wrench (T01).

4-3. Installation of the connector (200)

Put in position the connector (200) and the protector (-240) with the washer (220) and the screw (210).

4-4. Installation of the cells (320)

Put cells (320) in the side compartments.

Put four cells (320) in the middle of each compartment.

Move the last cell into position (if it is difficult to put in the last cell, remove one or two spacers).

Carefully position the cell (320) and push onto terminals with a piece of soft wood.

Tighten and check the torque of all lower cell nuts (350) (refer to [FITS AND CLEARANCES](#)).

Install the links (270 thru 310).

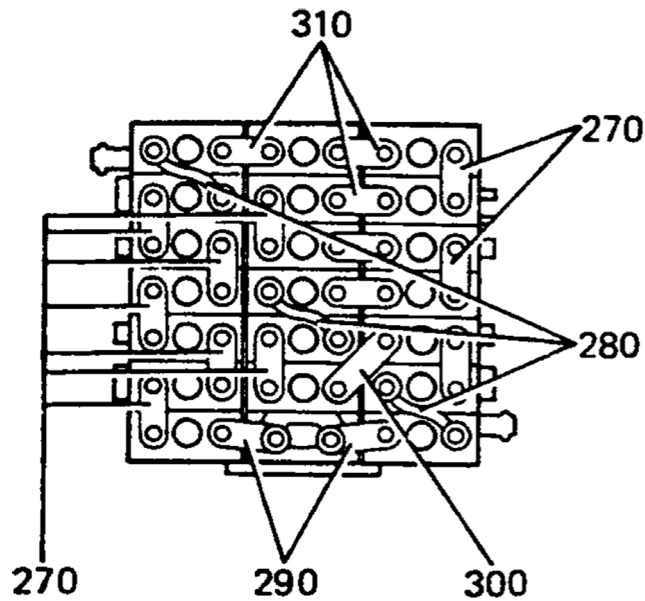

Figure 7002 Battery circuit

Install the spring washers (360).

Install the nuts upper (350) and torque them according to [FITS AND CLEARANCES](#) chapter.

Lightly lubricate the terminals and the links with [M02](#) (use a paintbrush).

Install the cover complete (050) and attach it.

4-5. Recording

Fill out identification plate (080) if the box (020) has been changed.

Fill out the log book.

FITS AND CLEARANCES**1. Introduction**

The torque values below are "lube torque" values. The thread of the terminals and attaching nuts (or screws) should be lightly greased with (M02) prior to assembly and applying torque.

2. Torque table

IPL FIG ITEM N°	NAME	TORQUE VALUE	
		N.m	lbf.in
nut 250	Nut	12 to 14	106 to 124
upper nut 350	Nut	12 to 14	106 to 124
lower nut 350	Nut	4.5 to 5.5	39.2 to 47.8

PAGE INTENTIONALLY LEFT BLANK

SPECIAL TOOLS, FIXTURES, EQUIPMENT AND CONSUMABLES

1. Introduction

This chapter is divided into two parts:

- The first part provides the list of special tools, fixtures and equipments needed to do the steps listed in the other chapters.
- The second part provides the listing of consumable materials used in this manual.

All listed items are identified in this manual by a standard code number:

- Txx for tools, fixtures and equipment,
- Mxx for consumable materials.

2. Standard tools

The following items are recommended to do the procedures described in this manual. When necessary, equivalent substitutes may be used.

- Constant Current Power Unit (0-60 A)
- Constant Current Load Bank (0-60 A)
- Megohmmeter (0-50 M Ω @ 250 V continuous)
- Precision Multimeter (Volt, Ω , mA)
- Torque Wrench (Fully insulated) 0-15 N.m (0-133 lbf.in)
- Standard mechanic's tools.
- Safety gloves.
- Protective goggles.
- Safety shoes.
- Eye wash.
- Protective apron.
- Stiff bristle brush (non-metallic)
- Small paintbrush (non-metallic)
- Dry, compressed air source [less than 1.4 bar (20 psi)]
- Soft, clean cloth (at least two required)

3. Special tools

NOTE: Equivalent tools can be used.

A special tool kit (P/N 416161) is available from Saft containing all special tools T01, T02, T03, and T04. The tools are in a polypropylene box and each tool is insulated to ensure optimum safety for the technician.

CODE	DESCRIPTION	F6177 P/N	V09052 P/N
T01	Universal vent wrench	413876	093365-000
T02	Syringe assembly (with nozzle 20 mm (0.79 in))	416231	020915-004
T03	1 Ω 3 W equalizing resistors	164829	
T04	Universal cell extraction tool	416159	
T05	Vent valve adapter for M8 valve	-	025098-000

4. Consumables

NOTE: Equivalent alternatives can be used for list items.

This paragraph describes the consumables used in the OMM.

CODE	DESIGNATION PARTNUMBER AND SPECIFICATION	MANUFAC- TURER OR SUPPLIER (NAME, ADDRESS, CODE)
M01	Distilled or deionized water clear, colorless, odorless while boiling, resistivity > 30 k Ω /cm 5 < pH < 7 Absence of organic and reducing substances. Reducing agent content (expressed in weight of oxygen) < 30 mg/l (test with permanganate). Total of ions SO ₄ ²⁺ Cl ⁻ < 10 mg/l Dry abstract < 15 mg/l Silicium in SiO ₂ < 15 mg/l	Local vendor
M02	Neutral petroleum jelly Density @ 60°C (140°F) Range = 0.840 - 0.866 Kg/L Melting Point Range = 46°C - 52°C (115°F - 126°F) Acidity/Alkalinity = Neutral to Litmus	Mineral vaseline NATO: S 743 F: AIR 3565 US: VV-P-236/A UK: DEF 2333
M03	Soap	Local vendor

Table 1 - List of consumables

ILLUSTRATED PARTS LIST

1. Introduction

1-1. General

The Illustrated Parts List (IPL) contains a list and illustrations of the assemblies and detailed parts of the unit in disassembly sequence.

To find the illustration for a part if the part number is known, refer to the [Alpha numerical index](#) and look for the part number and the corresponding figure and item number. Refer to the [Detailed part list](#) and look for the first figure and item number found in the [Alpha numerical index](#) for that part. If this figure shows the part in a section or system of the equipment other than the one necessary, refer to the other figure numbers listed in the Numerical Index.

To determine the part number of a given part, refer to the illustration showing the assembly including this part. Note the item number of the illustrated part and refer to the [Detailed part list](#) which indicates its part number and identification.

1-2. Numerical Index

In this index, part numbers are classified from left to right, each character (letter, number, hyphen) being considered separately.

The part number column contains all part numbers included in the [Detailed part list](#).

1-3. Detailed Parts List

1-3-1. Figure and Item Number

Each assembly, sub-assembly and part holding a part number and included in the parts list is given as an item number.

The figure number linked to the item number is shown on the first line at the top of each page.

Assemblies, sub-assemblies numbered parts included in the list but not illustrated are identified by a hyphen (-) preceding the item number.

An index letter shown before the item number refers to the figure showing the modified portion of the applicable part.

Manufacturer's Part Number: a manufacturer's part number is given to each assembly and detail part, whether illustrated or not.

Nomenclature: the nomenclature is given with an indenture, to show how the parts and the assemblies and related to their next higher assemblies. These are the details:

1 2 3 4 5 6 7

Assembly

. Detailed parts for assembly,

. Sub-assembly

. Attaching parts and/or storage parts for sub-assembly,

* * *

. . Detailed parts for sub-assembly

. . Sub-sub-assembly,

. . Attaching parts and/or storage parts for sub-sub-assembly,

* * *

. . . Detailed parts for sub-sub-assembly.

The attaching parts are shown directly after the assembly of the part thereof. They are listed under the same indent number as the item they are attached to, and are identified by the words "Attaching Parts" and are followed by three asterisks.

The manufacturer's code or the abbreviation NP (not procurable) are placed at the extreme right- hand side of the first line of the parts list column.

1-3-2. Effectivity code

An alphanumeric index indicates the effectivity of sub-assemblies and detailed parts lists in relation to the next higher assembly (ies) or sub-assembly (ies).

When the effectivity is fully applicable, the usage code column remains blank.

The use code for assemblies and detailed parts refers to the figure/item number of the next higher assembly (ies) or sub-assembly (ies). Example: Effectivity 1A, 1B, 1C is written 1ABC.

1-3-3. Units per Assembly

The units per assembly column shows the quantity of units required for one next higher assembly.

In some cases, the information is replaced by the abbreviation RF (for reference) or AR

2. Alpha numerical index

Part Number	Airline Stock Number	Figure Number	Item Number	Total required
2758			001	1
012187			310	5
013294			290	2
062007			250, 350	82
100078			180	80
100094			260, 360	82
100430			220	4
100431			210	4
100694			370	1
100713			230	1
102392			200	1
117704			120	1
166309			100	2
166314			090	1
166925			-240	1
410406			320	20
410741			030	2
410895			040	2
411053			020	1
411065			050	1
411066			010	1
411070			270	10
411071			300	1
411109			080	1
411440			130	1
411691			280	3
413609			110	2
413611			-075	2
415218			325	1

3. Detailed part list

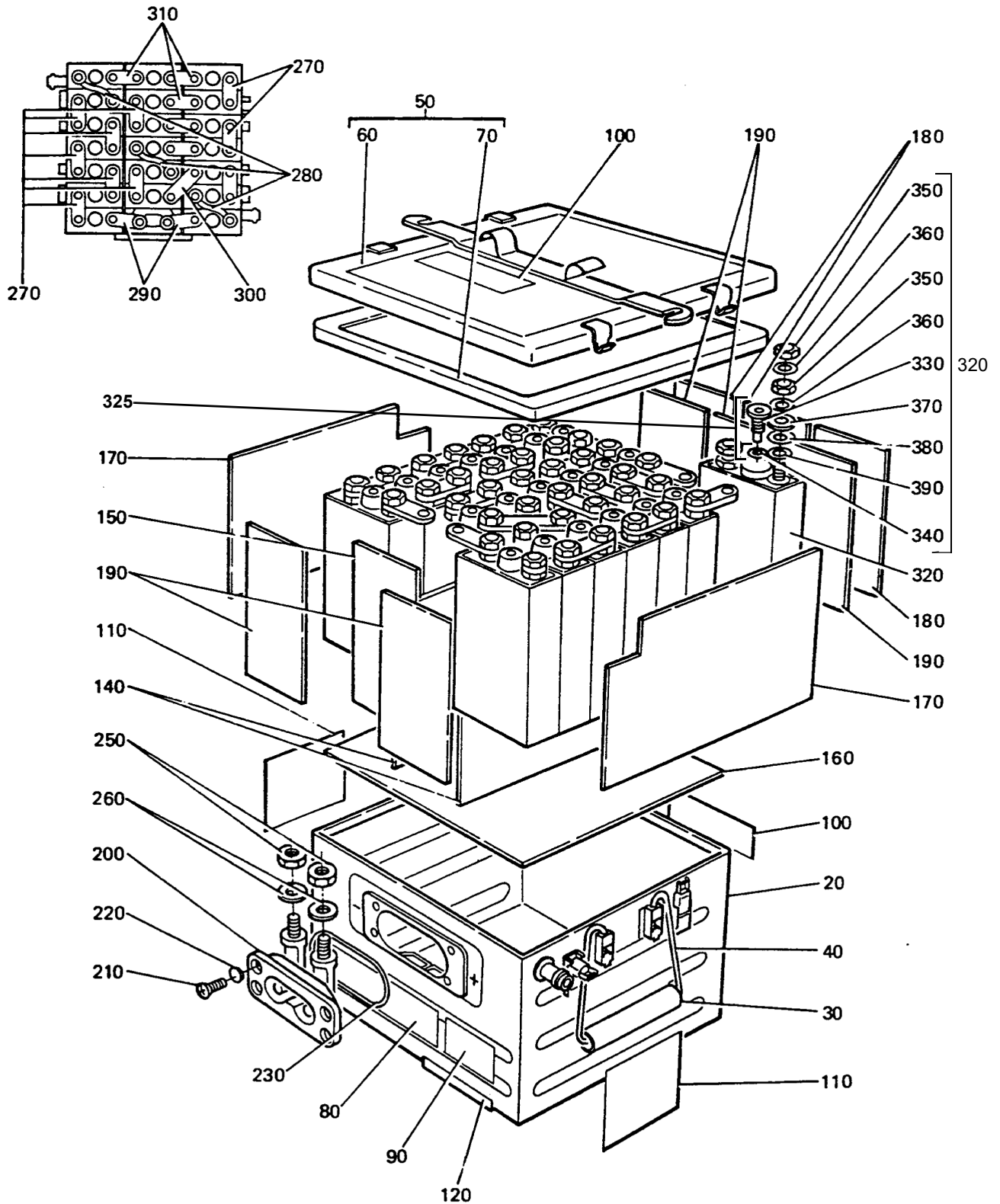

Figure 10001 [2758](#) Nickel-Cadmium Aircraft Battery

Component Maintenance Manual 2758

Figure Number	Item Number	Part Number	Airline Stock Number	Nomenclature		Quantity per Battery
				1 2 3 4 5 6 7		
1	001	2758		BATTERY 2758 , drawing number 410946		
	010	411066		. Box and cover, complete		1
	020	411053		. Box assembly		1
	030	410741		. . Tube, handle		2
	040	410895		. . Handle, strap		2
	050	411065		. . Cover, complete with gasket		1
	060	-		. . . Cover, assembly		1
				NP		
	070	-		. . . Gasket cover		1
				NP		
	-075	413611		. Plate, range label		2
	-078	160158		. Film, protector		1
	080	411109		. Plate, identification		1
	090	166314		. Plate, amendment		1
				DELETED		
	100	166309		. Plate, filling instruction		2
	110	413609		. Plate, SAFT label		2
	120	117704		. Plate, code		1
				DELETED		
	-125	280068		. Plate, recycling		1
	130	411440		. Liner-spacer kit		1
	140	-		. . Spacer		
				NP		
	150	-		. . Spacer		
				NP		
	160	-		. . Spacer		
				NP		
	170	-		. . Spacer		
				NP		
	180	-		. . Spacer		
				NP		
	190	-		. . Spacer		
				NP		
	200	102392		. Connector, complete		1
	210	100431		. Screw, F/90 M4/10		4
	220	100430		. Washer, lock		4
	230	100713		. O-ring, 56.75		1
	-240	166925		. Protector		1
	250	062007		. Nut, M10x1.25		2
	260	100094		. Washer, spring		2

Component Maintenance Manual 2758

Figure Number	Item Number	Part Number	Airline Stock Number	Nomenclature							Quantity per Battery	
				1	2	3	4	5	6	7		
	270	411070		.	Link, E34							10
	280	411691		.	Link, curved							3
	290	013294		.	Link, E36							2
	300	411071		.	Link, E49							1
	310	012187		.	Link, E33							5
	320	410406		.	Cell, VHP230KA-3 , assembly							20
	325	415218		.	Vent valve assembly							1
	330	-		.	Vent valve					NP		1
	340	-		.	O-ring					NP		1
	350	062007		.	Nut, M10x1.25							4
	360	100094		.	Washer, spring							4
	370	100694		.	Washer, positive polarity							1
	380	100078		.	Washer, flat							2
	390	-		.	O-ring					NP		2

- Item not illustrated.

STORAGE (INCLUDING TRANSPORTATION)

1. Introduction

1-1. General

Storage preparation and packaging makes sure that the equipment is protected against any attack by atmospheric agents. The figure and item numbers are those of the [ILLUSTRATED PARTS LIST](#) chapter.

1-2. Storage room

Keep the batteries and spares in a dry and clean room.

1-3. Temperature conditions

The recommended temperature range is + 20 °C ±15 °C (68 °F ±27 °F). However, occasional excursion into the range of - 60 °C to +60 °C (-76 °F to +140 °F) is permitted.

2. Storage procedure

2-1. Short term storage

2-1-1. Preparation of the battery for short term storage

Service the battery as scheduled (periodical check, regular check or general overhaul check). The battery is fully charged at this step.

Lightly lubricate the nuts, the links, and all the components that can be damaged by atmospheric corrosion with [M02](#).

Put the battery in its usual vertical position.

2-1-2. Periodic refresh charge

The battery can stay in storage for a period shorter than the time necessary to reach 80% of capacity. This duration depends on storage temperature according to Figure 15001 : for instance 60 days at 25°C, with a maximum of 90 days.

If the storage has to be extended beyond this duration, perform a refresh charge at the end of the period. The refresh charge is defined as a short charge until the battery voltage reaches the value given in the table below

Curent	End of charge voltage	Maximum duration
2.3 A	30 V	2 h
11.5 A	31 V	24 min
23 A	31.4 V	12 min

If the maximum duration is exceeded, do a [Regular check](#). After the Regular check, the battery can be refreshed again according to the refresh charge procedure.

The battery can be refreshed 2 times allowing a maximum storage duration of 3 periods. For example at 25°C, the storage can be extended to 180 days.

2-1-3. Placing the battery back to service

The short term storage procedure can be interrupted at any time to install the battery back onboard an A/C without the need of further check.

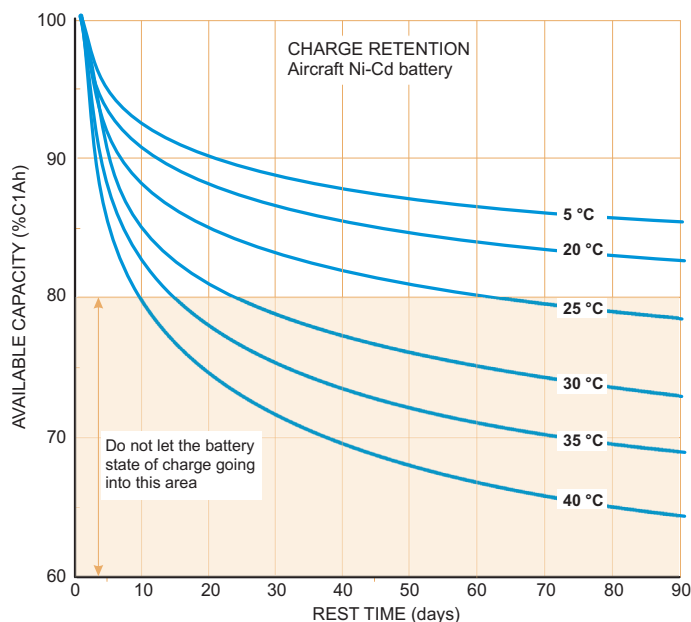

Figure 15001 Short term storage

2-2. Long term storage (discharged battery)

Caution: Saft Ni-Cd batteries may be stored in temperatures ranging from - 60 °C (67 °F) to + 60 °C (+ 140 °F) for short periods of time without harming the battery.

The standard cardboard packaging is considered unsealed and allows 2 years of storage under the above conditions.

No maintenance operation needs to be done during the storage period.

Lead batteries must be stored in a different room.

2-2-1. Operations

Discharge to 20 V.

Light greasing of cell terminals.

Place in a storage room.

2-2-2. Conditions

The battery should be stored filled and discharged.

The storage life is 10 years, if using the following conditions:

- Sealed packaging.
- Temperature: + 20 °C ± 15 °C (68 °F ± 27 °F).
- Humidity: < 70 %.
- Normal vertical position.
- Isolated from detrimental agents: dirt, dust, humidity, vibration, corrosive atmosphere.

2-2-3. Packaging

The batteries and cells are usually put in cardboard boxes. For long storage, we recommend to put them in a heavy gauge plastic bag that is subsequently heat sealed. In this type of container, with the recommended temperature range, the batteries can be kept for 10 years.

2-2-4. Servicing after discharged storage

Storage time	Servicing procedure
Less than 3 months	Visual inspection Insulation check Nut tightness charge Adjust electrolyte level.
3 months to 1 year	Charge followed by Periodical check
More than 1 year	Charge followed by Regular check

3. Transportation procedure

The battery is normally discharged before packing. If it is necessary to transport a charged battery, make sure that the output terminals are protected against short circuit.

The battery should then be packed vertically in its original container. If the original container is not available, the international and/or local packaging regulations applicable to the mode of transport and destination must be followed.

According to IATA/IMDG dangerous goods regulations, Nickel Cadmium aviation batteries as well as individual aviation Nickel Cadmium cells must be shipped under the UN 2795 classification (wet, filled with alkali) according to packing instruction 801.